

LTP interferometer—noise sources and performance

David Robertson¹, Christian Killow¹, Harry Ward¹, Jim Hough¹,
Gerhard Heinzel², Antonio Garcia², Vinzenz Wand², Ulrich Johann³
and Claus Braxmaier³

¹ Department of Physics and Astronomy, Institute for Gravitational Research,
Glasgow University, Glasgow G12 8QQ, UK

² Max-Planck-Institut für Gravitationsphysik (Albert-Einstein-Institut), Callinstrasse 38,
D-30167 Hannover, Germany

³ EADS-Astrium GmbH, 88039 Friedrichshafen, Germany

E-mail: d.robertson@physics.gla.ac.uk

Received 10 November 2004, in final form 28 January 2005

Published 21 April 2005

Online at stacks.iop.org/CQG/22/S155

Abstract

The LISA Technology Package (LTP) uses laser interferometry to measure the changes in relative displacement between two inertial test masses. The goals of the mission require a displacement measuring precision of $10 \text{ pm Hz}^{-1/2}$ at frequencies in the 3–30 mHz band. We report on progress with a prototype LTP interferometer optical bench in which fused silica mirrors and beamsplitters are fixed to a ZERODUR[®] substrate using hydroxide catalysis bonding to form a rigid interferometer. The couplings to displacement noise of this interferometer of two expected noise sources—laser frequency noise and ambient temperature fluctuations—have been investigated, and an additional, unexpected, noise source has been identified. The additional noise is due to small amounts of signal at the heterodyne frequency arriving at the photodiode preamplifiers with a phase that quasistatically changes with respect to the optical signal. The phase shift is caused by differential changes in the external optical paths the beams travel before they reach the rigid interferometer. Two different external path length stabilization systems have been demonstrated and these allowed the performance of the overall system to meet the LTP displacement noise requirement.

PACS numbers: 04.80.Nn, 07.60.Ly, 07.87.+v, 95.55.Ym, 95.75.Kk

1. Introduction

The LISA PathFinder (LPF) project [1] is a mission to test some of the key technologies for LISA, the space-based gravitational wave detector [2]. The LISA Technology Package (LTP) is one of the test packages on LPF. The role of the interferometer on LTP is to provide

independent measurements of the displacement of one of the test masses relative to the spacecraft, and of the relative displacement of two inertial sensors in the spacecraft. The performance required is $10 \text{ pm Hz}^{-1/2}$ at frequencies in the 3–30 mHz band. The LTP interferometer will consist of multiple, non-polarizing Mach–Zender interferometers mounted on a baseplate of low expansion glass ceramic (ZERODUR®). The interferometry and layout of the LTP engineering model (EM) optical bench are described in [3]. The construction techniques used in the assembly of both the LTP EM optical bench, and the test bench used in the experiments detailed here, are described in [4]. The aims of the experiments in Glasgow were to demonstrate construction using hydroxide catalysis bonding of a heterodyne interferometer of the type planned for LTP, and to demonstrate close to the LTP level of dimensional stability in a rigid, bonded interferometer. The construction of the interferometer is detailed in [5].

2. Experimental layout

To provide the laser signals for the heterodyne interferometer light from a Nd:YAG laser operating at $\lambda = 1064 \text{ nm}$ is split into two equal beams and the original laser frequency is shifted by two acousto-optic modulators (AOMs). The AOMs are driven by two phase locked signal generators, set to 80 MHz and 80.01 MHz, and generate two optical beams with a frequency difference of 10 kHz. These two beams are then launched into two single mode optical fibres that take them from the beam preparation bench, through a vacuum feedthrough, and onto the optical bench, which is mounted inside a vacuum tank. On the optical bench some light from each beam is split off and interfered to provide a reference output signal at the 10 kHz heterodyne frequency. The main beams travel a longer path on the bench before being interfered to provide the measurement output. The changes in the phase difference between the 10 kHz reference and measurement signals correspond to differential changes in the optical paths on the bench, with a phase change of 1 cycle corresponding to a differential path length change of $1 \text{ }\mu\text{m}$. To minimize the coupling of laser frequency noise, the optical paths in these interferometers are matched in length (see section 3.1). We include a third interferometer with a large path length difference to maximize the sensitivity to laser frequency noise, and thus be able to measure it. The phase differences between the output signals are measured using a ‘stopwatch’ style phase meter (section 3.6 and [6]).

3. Noise investigations

A large number of potential noise sources could prevent both the prototype optical bench reaching the desired stability goal and the interferometric system from giving a true reading of the dimensional stability of the bench. We have investigated the major potential noise sources and detail the investigations and their results below. All the experiments were carried out with the vacuum tank at a pressure of 10^{-2} Torr.

3.1. Laser frequency noise

If the measurement and reference beam paths in the interferometer are not equal in length then the output signal from the interferometer will be sensitive to laser frequency noise. The apparent length change (δx) will depend on the path length imbalance (Δx), the laser frequency noise ($\delta \nu$) and the laser frequency (ν). The coupling is given by

$$\delta x = \Delta x \frac{\delta \nu}{\nu}. \quad (1)$$

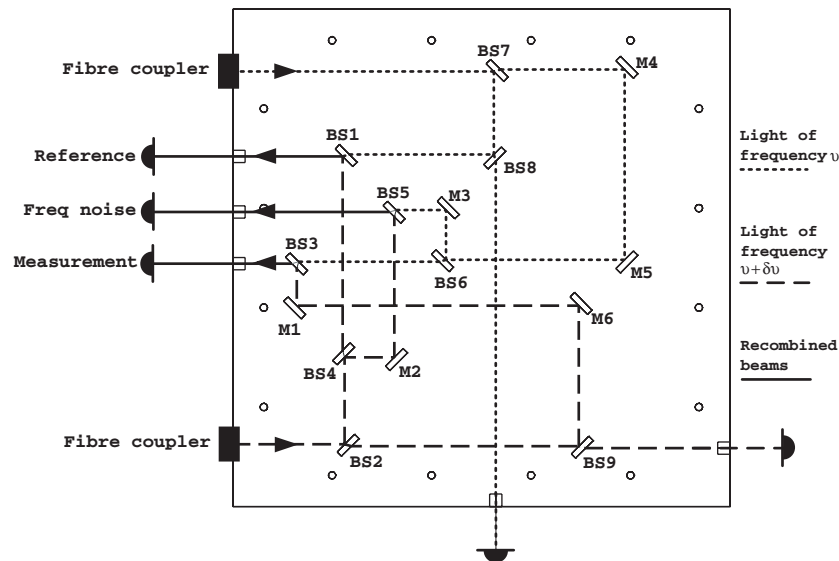

Figure 1. Schematic diagram of the layout of the optical bench.

In the prototype optical bench we have an interferometer that has a deliberately large path length difference (Δx_f) of 30 cm. This allows us to measure the laser frequency noise with a noise level of 20 kHz $\text{Hz}^{-1/2}$ in the measurement band.

3.1.1. Laser frequency noise subtraction. To calibrate the path length difference between the reference and measurement paths (Δx_s), we modulated the laser frequency by applying a signal to a piezo-electric element (PZT) glued to the laser crystal. The modulation was applied at 1 Hz. This produced a signal at the modulation frequency in both the measurement and frequency noise outputs. The relative size of these signals gives the ratio of coupling of laser frequency noise in the two signals and thus allows the effect of laser frequency noise to be subtracted from the measurement signal. We can also use the same data, and knowledge of Δx_f , to calculate the value of Δx_s . This was found to be 2.0 mm.

Δx_s is the difference in optical path lengths between various beamsplitters on the optical bench. It is defined in equation (2), using the labelling of figure 1.

$$\Delta x_s = [(\text{BS7 to BS3}) - (\text{BS7 to BS1})] - [(\text{BS2 to BS3}) - (\text{BS2 to BS1})]. \quad (2)$$

A comparison of the performance of the optical bench with and without subtraction of laser frequency noise is shown in figure 2.

3.1.2. Laser frequency stabilization. An alternative to subtracting the effect of laser frequency noise in processing the data is to stabilize the laser frequency. To test this approach we implemented a laser frequency stabilization system. The error signal was, as above, the phase difference between the reference and frequency noise outputs of the interferometer. The signals were amplified and filtered through some analogue electronics and fed back to the laser PZT and crystal temperature to control the laser frequency. The control system had a bandwidth of 800 Hz and a gain at 1 Hz of order 10^3 . The apparent path length stability was essentially identical to that achieved using frequency noise subtraction, showing that, as expected, either system could be employed to mitigate the effect of laser frequency noise.

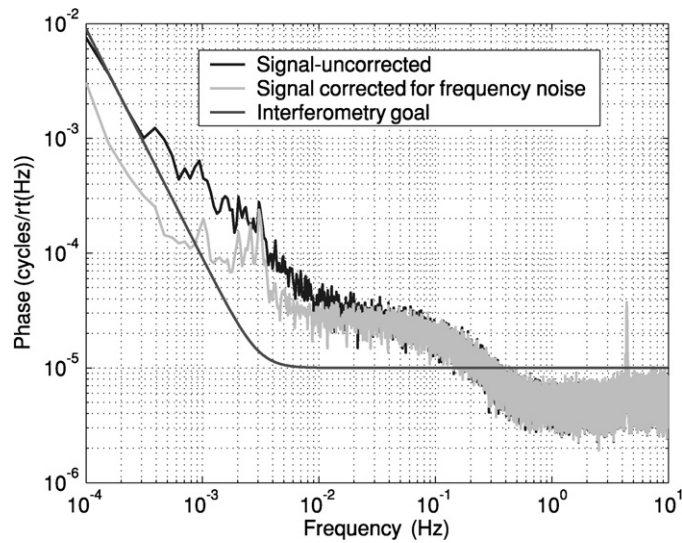

Figure 2. The apparent path length stability on the prototype optical bench, showing the performance without (black) and with (grey) the subtraction of laser frequency noise. Below 0.2 Hz the noise is above the LTP interferometry performance goal (smooth line), even with the laser frequency noise subtracted.

With either laser frequency noise subtracted, or with the laser frequency stabilized, the interferometer does not meet the performance goal at frequencies between 3 mHz and 200 mHz. The following sections investigate possible sources of this excess noise.

3.2. Laser power noise

The light power in each arm of the interferometer may vary as the laser power varies, or as the transmission of the optical paths from the laser to the prototype optical bench varies. We can sample the power in each arm of the interferometer by looking at the light transmitted through beamsplitters BS8 and BS9 (figure 1). For each monitor point, we stabilized the detected optical power using a feedback system that controlled the level of the RF drive to the corresponding AOM. The control system had a bandwidth of around 10 kHz and a gain at 1 Hz of $>10^3$. This produced no change in the apparent path length stability on the bench.

3.3. External optical path noise

The output signal from the optical bench is the phase difference that is measured between the 10 kHz signals at the reference and measurement optical outputs. If the phase of these signals is compared to a 10 kHz signal generated by mixing the two RF drive signals to the AOMs then we see large phase deviations. These phase deviations are caused by differential path length changes in the external optical paths; that is the paths that the two beams follow from the laser, through different AOMs, different air paths on the beam preparation bench and through different optical fibres onto the rigid optical bench. These phase differences were expected. They should be completely common mode between the reference and measurement signals, and so should not affect the measured performance of the bench. However in order to try and track down the remaining excess noise in the bench performance we measured this phase noise (figure 3), and tested two different systems to control the noise (sections 3.3.1, and 3.3.2).

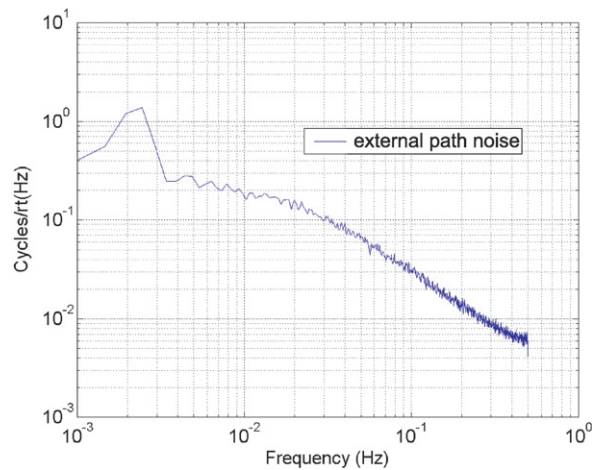

Figure 3. The external optical path length noise.

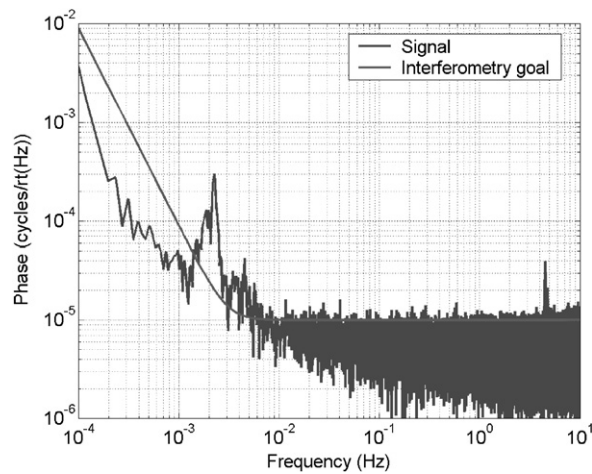

Figure 4. The apparent path length stability on the prototype optical bench with the PZT fibre path length stabilization system active. Also shown is the LTP interferometry performance goal (smooth line).

3.3.1. Path length stabilization—PZT drive. In order to be able to control the difference in optical path length before the prototype optical bench we mounted one of the mirrors on the beam path into one of the fibres on a piezo actuator. This actuator had a range of $100\ \mu\text{m}$. The error signal was the phase difference between the electrical reference signal and the reference output of the interferometer. The signals were amplified and filtered through some analogue electronics and fed back to the mirror PZT. The control system had a bandwidth of 10 Hz and a loop gain at 1 Hz of order 30. The performance of the prototype optical bench using this system is shown in figure 4. It meets the LTP performance goal over the whole frequency range apart from a some excess noise around 2 mHz. This excess noise has the same spectral shape as the room temperature variations during this data run (figure 5). Different data runs have shown very similar correspondence between temperature and excess

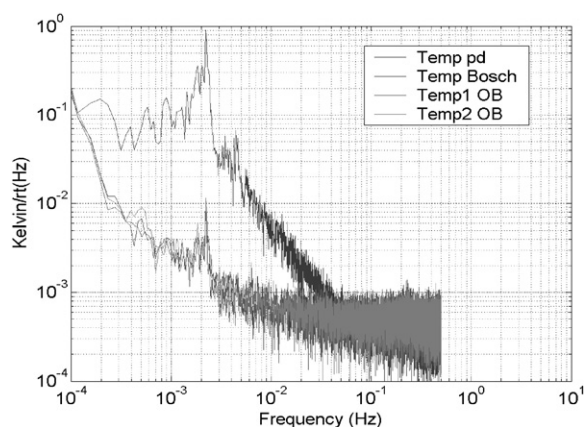

Figure 5. The spectrum of temperature variations during the taking of the data shown in figure 4. The higher graph is the temperature variations seen at one of the photodiodes (which are mounted outside the vacuum tank) the other three traces are temperatures measured by sensors mounted at various points inside the vacuum tank. These later three are probably dominated by sensor noise above 3 mHz.

noise spectra, but with different spectral shapes. It seems likely that the excess noise is caused by temperature-driven effects.

3.3.2. Path length stabilization—temperature drive. While the PZT control system described above worked well, we decided to investigate driving the temperature of the optical fibres as an alternative control method. To do this we wrapped 30 cm of each fibre in Nichrome heater wire. Both fibres were then heated above room temperature and their temperatures then driven differentially. Using a similar control loop to the above, but with the temperature feedback, we were able to achieve a control system with a somewhat lower bandwidth of 4 Hz and a gain at 1 Hz of order 5. Using this control system the performance of the prototype optical bench was essentially the same as with the PZT control system already described.

3.3.3. Why does path length stabilization matter? There must be some spurious signal present on the output signal from the reference and measurement photodiodes that is at the heterodyne frequency and is phase stable with respect to the RF drive signals, and so varying in phase with respect to the optical heterodyne signal. Stabilizing the phase difference between the spurious signal and the optical heterodyne signal removes the effect on our rigid optical bench. In the real LTP, with a changing phase between the reference and measurement signals, this same effect will lead to a periodic nonlinearity in LTP output signal. The cause of this spurious signal is most probably a small level of electrical cross-talk between the RF drive signals. This will lead to the 80 MHz AOM being driven with a additional small signal at 80.01 MHz (a similar effect will also occur in the 80.01 MHz AOM). Each AOM will therefore generate two optical beams, virtually collinear, but separated in frequency by 10 kHz, and when detected on a photodiode this will give a spurious 10 kHz signal. Looking on the output of the photodiodes with only one of the light beams present we see a signal at the heterodyne frequency that is 94 dB below the level of the main heterodyne signal, a level that could explain the excess noise observed.

The AOMs used to produce the frequency shifted optical beams also produce some amplitude modulation (AM) at their drive frequencies. If these AM signals are mixed in

the photodiode/preamplifier system (due to nonlinearities in the system) then this could also produce a spurious signal at the heterodyne frequency.

3.4. Noise due to temperature variations

In section 3.3 we saw that it seemed likely that temperature effects were limiting the performance of the prototype optical bench. We had previously tested the phasemeter and had seen no significant temperature sensitivity in its performance. To further test the temperature sensitivity of the bench we mounted small heaters (torch bulbs) and further temperature sensors besides various key components. The aim was to modulate the temperature of the component, measure the level of temperature modulation, and see if there was a signal at the modulation frequency in the apparent path length stability on the bench. The typical temperature modulation was of order $0.1 \text{ K}_{\text{p-p}}$. The temperature sensors are as closely coupled as possible to the components they are sensing, however there is still some uncertainty that the measured temperature is really that of the component being tested. The temperature couplings measured in the following sections should thus be taken only as estimates.

3.4.1. Fibre injectors. One possible source of temperature-driven error would be beam angular changes induced by temperature variations in the fibre injectors. Testing with a temperature modulation of frequency 5 mHz we saw an effect of order 100 pm K^{-1} . With this level of coupling, the temperature variations inside the vacuum tank would not produce a significant excess noise signal. The fibre injectors used are off the shelf items and not representative of those to be used in the final LTP design.

3.4.2. Optical bench. There are two obvious ways in which temperature variations could affect the stability of the bench. The first is thermal expansion of the bench, and the second is thermally driven changes in the optical length of the transmissive optics (the beamsplitters). The latter effect is a combination of physical length change and change of refractive index with temperature. For either of these effects to be a problem there must be differential effects between the two paths in the interferometer. From the physical properties of the materials used we can calculate worst case coupling factors to be $7 \times 10^4 \text{ pm K}^{-1}$ for expansion of the baseplate and $1 \times 10^5 \text{ pm K}^{-1}$ for the effects of the transmissive optics. In practice we would expect common mode effects to significantly reduce the level of this coupling. When driving the temperature of the whole bench a coupling of around $2 \times 10^4 \text{ pm K}^{-1}$ was observed and when driving the temperature of an individual beamsplitter the coupling was also around $2 \times 10^4 \text{ pm K}^{-1}$. To explain the level of excess noise seen in the measurements a coupling factor of $3 \times 10^4 \text{ pm K}^{-1}$ would be required. Given the uncertainties in the measurements of the coupling factor, temperature variations on the optical bench could certainly explain the level of excess noise observed.

3.4.3. Photodiodes. The photodiodes sit outside the vacuum tank and see greater temperature variations than the optical bench, which benefits from the passive thermal isolation provided by the vacuum tank (a factor of around 100 at 2 mHz, see figure 5). When driving the temperature of a single photodiode, the observed coupling factor to apparent length changes on the optical bench is of the order of $2 \times 10^2 \text{ pm K}^{-1}$. Again we might expect the coupling factor to be lower in operation as the temperature variations should be partially common mode between photodiodes. Again this coupling factor could explain the level of excess noise observed.

3.4.4. Conclusion. The level of thermally driven excess noise is likely to be a combination of thermal effects on the substrate and components of the optical bench and of thermal effects in the photodiodes.

3.5. Photodiode alignment

The output beams from the optical bench were detected on photodiodes mounted outside the vacuum tank. To achieve the optimal alignment of the beams onto the photodiodes we mounted the photodiodes on x - y micrometer stages. The output beam diameters were 0.87 mm and the photodiodes had a diameter of 5 mm.

We measured the positional variations of the output beams and the positional sensitivity of the phase detected by the photodiodes. These effects could combine to produce excess noise, but are low enough in our experiment to be discounted.

3.6. Different phasemeter

The preceding measurements were all taken using a ‘stopwatch’ style phasemeter. This phasemeter converts the photodiode output signals to square waves and counts the number of pulses of a fast clock between rising edges of the two signals whose phase is being compared. The phasemeter chosen for LTP is of a different type. It samples the photodiode output signals directly using a fast ADC, and digitally computes the phase difference. A detailed description of this phasemeter can be found in [7]. We installed a prototype LTP style phasemeter on the prototype optical bench to test the combined performance of the phasemeter and optical bench. The performance with the LTP style phasemeter were similar at low frequencies and slightly improved in the 0.1–3 Hz range, reflecting the lower quantization noise of this phasemeter.

3.7. Quadrant photodiodes

The LTP will use quadrant photodiodes to detect the optical signals, to allow the sensing of angular as well as longitudinal displacements of the test masses. We installed a quadrant photodiode on one of the output beams and summed the signal from the four quadrants in the phasemeter. This gave a noise level of $100 \text{ pm Hz}^{-1/2}$. This noise is much worse than with a single element photodiode and is probably the result of beam jitter across the photodiode combined with the loss of some light in the ‘dead space’ between the sectors of the photodiode. In our experiment the photodiodes are mounted separately from the optical bench. In the LTP EM optical bench the photodiodes are mounted directly on the bench which greatly reduces this noise source [8].

4. Conclusions

We have demonstrated the performance, at the LTP interferometry goal, of a combined system of an LTP style prototype optical bench, the LTP interferometry system and an LTP style phasemeter. In addition we have characterized the main noise sources associated with the interferometry. We have also identified an unexpected noise source in the interferometry and developed strategies for its ameliorization.

Acknowledgments

We would like to thank many members of the LISA and LTP teams for many interesting and useful discussions. This work was funded by the European Space Agency and by the Particle Physics and Astronomy Research Council.

References

- [1] Bortoluzzi D *et al* 2003 Testing LISA drag-free control with the LISA technology package flight experiment *Class. Quantum Grav.* **20** S89–S97
- [2] Danzmann K and Rüdiger A 2003 LISA technology—concept, status, prospects *Class. Quantum Grav.* **20** S1–S9
- [3] Heinzel G, Braxmaier C, Schilling R, Rüdiger A, Robertson D, te Plate M, Wand V, Arai K, Johann U and Danzmann K 2003 Interferometry for the LISA technology package (LTP) aboard SMART-2 *Class. Quantum Grav.* **20** S153–S161
- [4] Elliffe E J, Bogenstahl J, Deshpande A, Hough J, Killow C, Reid S, Robertson D I, Rowan S, Ward H and Cagnoli G 2005 Hydroxide-catalysis bonding for stable optical systems for space *Class. Quantum Grav.* **22** S257
- [5] Robertson D, Killow C, Ward H and Hough J Pre-investigation test plan and evaluation report: development of a SMART 2 optical breadboard constructed using hydroxide-catalysis bonding *Document SM2-ASG-TN-00x* submitted to ESA as part of the EM OB Contract TOS-MMO/2001/217
- [6] Jennrich O, McNamara P, Robertson D, Rowan S, Ward H and Hough J 2002 Interferometry developments for LISA and SMART-2 *Class. Quantum Grav.* **19** 1731–7
- [7] Heinzel G *et al* 2004 The LTP interferometer and phasemeter *Class. Quantum Grav.* **21** S581–S587
- [8] Braxmaier C *et al* 2004 LISA pathfinder optical interferometry *Proc. SPIE* **5500** 164–73