

Coincidence spectroscopy: past, present and perspectives

Tiberiu Arion¹ and Uwe Hergenhahn²

¹*Center for Free-Electron Laser Science/DESY, Notkestraße 85, 22607 Hamburg, Germany*

²*Max-Planck-Institut für Plasmaphysik, Wendelsteinstr. 1, 17491 Greifswald, Germany*

Abstract

Coincidence spectroscopy is a powerful spectroscopic method addressing the recording of more than one particle involved in an ionization process simultaneously. In the current manuscript, an overview of the available flavors of coincidence experiments is given, and new results on the Auger decay of CH₃F are discussed. An outlook of possible future experiments employing the approach is also briefly discussed.

Keywords: coincidence spectroscopy, PEPICO, PIPICO, PEPIPICO, PEPECO, APECS.

1. Introduction

An ionization process is inherently linked to the emission of (at least) one electron and the creation of (at least) one ion. There are vast numbers of studies investigating ionization processes, the large majority of which use either conventional electron spectroscopy or ion spectroscopy and spectrometry. By comparison, in only a small fraction of the studies more than one particle involved in the ionization process is recorded. This is the domain of *coincidence spectroscopy*.

Although the approach presents a number of challenges (combined solid angle of the spectrometers, speed of the electronics, ability to produce short strong voltage pulses, multi-hit ability etc.), a variety of sub-techniques have been developed over time. Further on, it has been applied to a variety of samples, ranging from experiments on gaseous species to investigations of solids. In the following, our article will deal with the plethora of research in this field, categorizing the experiments by the individual sub-techniques used. Depending on which particles will be detected in coincidence, one can distinguish the following categories: electron-ion coincidence (PEPICO), ion-ion coincidence (PIPICO), electron-ion-ion coincidence (PEPIPICO), ion-neutral coincidence and electron-electron coincidence. As will be shown in the following paragraphs, most of the coincidence experiments have been performed on gas targets, but recent investigations on solid-state samples point to a bright future for the coincidence perspective.

The purpose of the current review is to give a brief outline of the multitude of experiments performed so far, which could help newcomers to find their way into the field. However, an exhaustive review of the field is not pursued and is beyond the goal of this manuscript. There are with certainty experiments that will not be covered here.

2. *Experimental approaches*

Experiments on gas phase samples bear the great advantage that, due to the gas flow, every time the ionizing pulse reaches the interaction region, it will encounter a fresh sample. This particularity allows the experimenter to work with long data acquisition times, without having to worry about the sample being damaged through the interaction with the ionization radiation. As it will be shown further on, in coincidence experiments, long recording times are necessary in order to achieve reasonable statistics of the data sets.

Experiments on solid-state samples have a major advantage, over gas-phase, in what regards the sample density, and, implicitly, the count rate. However, in a coincidence experiment, it is desirable to work with relatively low count rates.

2.1. Electron, ion coincidence (PEPICO)

The essential elements making up an ionization process of matter are: an ionizing source (photon, electron beam, ion beam etc.), electrons being ejected in the ionization process, and ions, being 'left behind' after the ionization took place.

Consequently, one of the most straightforward coincidence experiments is to record concomitantly the released electrons and the ions produced during the ionization process. This spectroscopic tool bears the name Photoelectron-Photoion-Coincidence Spectroscopy (PEPICO), and has been in use since the 1970's [1][2][3][4][5][6][7].

The principle of a PEPICO experiment is shown schematically in Figure. 1. In short, subsequent to an ionization process, electrons and ions are produced in the extraction region of the electron and ion spectrometers. The flight time of the electrons to the detector will depend on their velocity, i. e. on their kinetic energy. The arrival of the electrons at the detector triggers a pulse applied on the extraction electrodes of the ion spectrometer, leading to the ions being accelerated towards the respective detector. The arrival time at the detector depends on the velocity and on the mass-to-charge ratio of the ion (mass analysis of the cations) [8]. The flight times of the electrons are usually of the order of several ns, whereas the ions need several μ s to reach the detector, such that one can approximate the formation of the ion with the detection instant of the electron (with reasonable error bars). Correlating the recorded particles in the analysis of the data, one can identify the electron-ion pairs corresponding to the same photoionization event.

In experiments on small molecules with moderate kinetic energies, for the ion extraction, usually low extraction field strengths (200 - 400 V/cm) are used. Maintaining these conditions is important as they ensure that the cationic fragments are sufficiently spread in time in the PEPICO spectra. However, choosing low extraction fields bears the disadvantage that mostly ions flying along the central axis of the spectrometer within a small (few degree) opening cone are detected, while the ions with a larger transversal velocity are less efficiently detected. Further on, Franklin *et al.* [9] have shown that, for small initial kinetic energies of a given ion (compared to the kinetic energies the cations accumulate when passing the extraction region), the flight time distribution ranges between a minimum and a maximum value corresponding to the cations flying directly towards- and opposite to the ion detector, respectively.

A somewhat simplified approach is to eliminate the intermediate stage of pulsing the extraction plates and keep the voltage on at all times. This approach was used in the earliest experiments [1][2][4], but the presence of a static, electric extraction field compromises the electron energy resolution. If however only the mass spectra of the produced ions are of interest, the loss of information on the electron energy is less detrimental. Static electric fields of some hundred/thousand V/cm can then be used to accelerate the ions and the electrons towards the respective detectors. The signal from electrons reaching the detector can then be used as a precise starting signal for time-of-flight measurements of the ejected cations. In other words, the electrons are recorded without any energy resolution due to the missing time information on their flight time. The mass resolution of the cation channel is preserved by this approach, enabling this this version of PEPICO to find a broad application in experiments where only the cationic fragments are sought. The acronym PEPICO is used for these experiments as well [10][11][12][13][14][15][16][17][18].

An important aspect in designing an ion spectrometer is the time-focusing condition [1][3][8], meaning that after passing the extraction region (of length d), the cations have to cross a field-free section (of length D) before being accelerated further towards the detector. The distance D has to be twice as long as d , in order for the slower ions to catch up with the faster ions, with the effect that, after exiting this section, any acceleration of the ions affects all cations in

the same way, independently of the initial ionization process. In a further refinement of this prerequisite, Eland [19] emphasized the importance of accounting for the initial positions and velocities of the ions (*second-order space focusing*), for achieving a superior time resolution. Compared to conventional electron spectroscopy, the PEPICO approach allows to gain some more insight in the ionization process, as proven also in a number of experiments on e.g. rare gases [20], CF₄ [21][22], CH₃F [23], N₂ [24], CF₃Br, SiCl₄ [25], C₄F₈ [26] or small clusters [27].

In a variant of the PEPICO method, an (energy resolved) Auger electron instead of a photoelectron is recorded [28][29][30][31][32][33][34]. These experiments allow to study the stability, or fragmentation pathways, of the doubly charged molecular final states after Auger decay.

However, this experimental method does not give a complete picture of the system if, subsequent to ionization, a fragmentation of the initial molecule takes place.

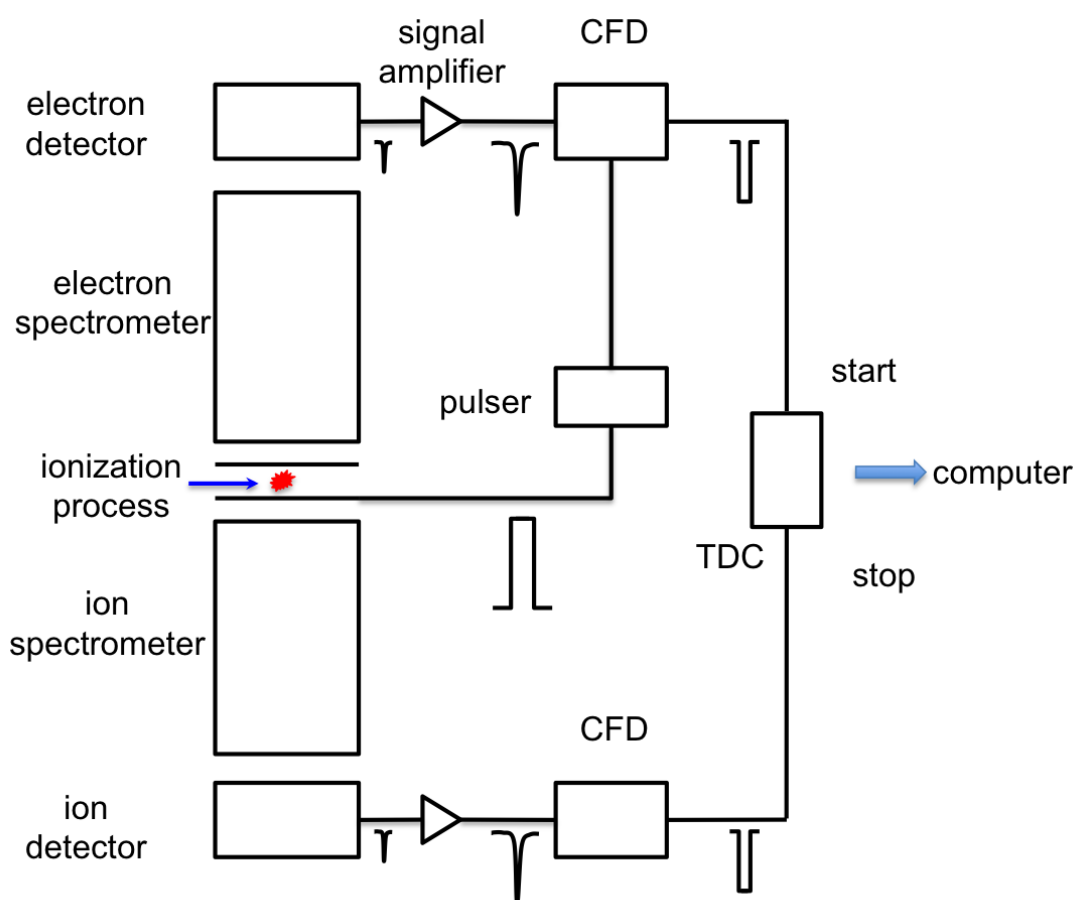

Figure 1. Schematics of a PEPICO experimental setup (see text for details). Ions and electrons produce electric signals in the respective detectors, typically a secondary electron multiplier (channeltron or microchannel plate). CFD: Constant Fraction Discriminator, which converts detector pulses into norm pulses with a stable timing, TDC: Time to digital converter.

2.2. Ion, ion coincidence (PIPICO)

A different approach of investigating a fission process is Photoion – Photoion – Coincidence Spectroscopy, where two ions (A⁺ and B⁺) emerging from the same fragmentation process are recorded as a function of the difference in their arrival time at the detector ($t_{A^+} - t_{B^+}$). In other words, the measurement is started with the faster ion (i.e. the lighter ion) and stopped with the

slower (heavier) fragment [35]. A variation of this technique, and, historically, the first record of ion, ion coincidence spectroscopic investigations [36], uses the signal from the emitted electrons of the initial ionization process as a start pulse for the measurement. The subsequent ions are both recorded as stop signals. Yet another flavor of the method is to trigger the measurement on the pulse of the ionizing source, as proven by Tsai and Eland [37]. The benefit of this approach over the former one is the certainty of starting a measurement with *every* ionizing pulse without having to rely on the detection efficiency of the electron spectrometer. This has the effect that it leads to a lower number of events being discarded and, consequently, to a better statistics.

The main advantage of using PIPICO instead of the PEPICO approach is that (in most of the cases) there is a need for only one ion spectrometer, without the necessity to add an electron detector. This technique is well suited for investigating small molecules (eg. H₂ [38], Br₂ [39], BrCN [40], CO₂ [41], OCS [42]) or small clusters [43][44], but not appropriate for probing large molecules or clusters due to the mixing of the mass spectroscopic lines pertaining to the different fragments with the same mass-to-charge (m/q) ratio but identical time-of-flight difference.

2.3. Electron, ion, ion coincidence (PEPIPICO)

If the ionization energy transferred to the target exceeds the double ionization potential, two (or several) ions can be created in an ionization process. In order to obtain a more complete picture of the fragmentation process in a molecule, one needs to record all cations resulting from the fission process. The experimental technique allowing the detection of an electron and two cations is called Photoelectron - Photoion - Photoion - Coincidence Spectroscopy. The schematics of the experimental setup is identical to the one presented in Figure 1, for the PEPICO approach, with the difference that the ion channel accepts two signals from different cations reaching the detector. The major difference between the two methods is that, in PEPICO the information is extracted from the correlation of the cation with the electron. By contrast, in a PEPIPICO experiment, the information on the various fragmentation pathways is inferred from the correlation maps of the fragment ions, defined by plotting the arrival time of the second fragment at the detector versus the flight time of the first ion [45][46][47][48][49][50][51][52][53]. Depending on the progress of the fission, the pattern of the coincidence map will be different, as described in a very comprehensive manner in ref. [46]. In short, one can differentiate between two-, three- and four-body processes, depending on the shape of the coincidence map, where the figure stands for the number of fragments involved in the decay.

A two-body process is schematically described by eq. (1) and is identified as taking the form of a line in the coincidence map.

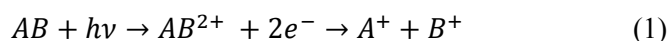

The slope of the line will be exactly -1 , in accordance with the momentum conservation law (back-to-back emission of the ionic fragments). Nevertheless, a curvature of the intensity distribution could occur if the travel times of the ions to the detector depend on the initial velocity or position of the parent ion (prior to the dissociation) as pointed out by Eland [19]. Three-body processes involve three different fragments, which can be either ionic or neutral, as indicated in eq. (2).

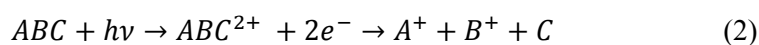

If the decay of the parent ion into three fragments takes place in a single step one is dealing with a *(i) concerted three-body dissociation*. By contrast, if the charge separation takes place subsequent to the release of a neutral particle, the process is called *(ii) deferred charge*

separation. A third distinct class of events is the (iii) *secondary decay*, where the emission of a neutral moiety takes place after the initial charge separation. The spectral signatures of these processes vary from a line -(i)- to a parallelogram -(ii) and (iii)- with the slopes of the edges depending on the masses of the ejected fragments.

Judging by the sequence in which the cations separate and the neutrals are emitted, one can sort four-body processes (see eq. (3)) into (i) *concerted four-body dissociation*, (ii) *deferred charge separations* and (iii) *secondary decays*.

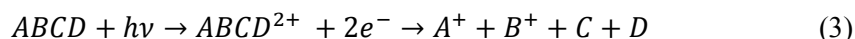

The *concerted four-body dissociation* (i) comprises the events where the parent ion decomposes into four fragments instantaneously, or the bond braking takes place so fast that it cannot be distinguished within the time frame of the experiment.

As the *deferred charge separation process* (ii) assumes a separation of the cationic fragments subsequent to the emission of two neutrals, it cannot be distinguished experimentally from a three-body charge separation where the neutrals would be ejected concomitantly. The spectral signature of such a process is a parallelogram with the slope of the longer edge of -1.

The evolution of *secondary decays* (iii) involves the release of neutral fragments after the initial charge separation. One can identify, therefore a (a) secondary decay after a deferred charge separation, when the emission of the first neutral occurs before the charge separation, making this path undistinguishable from a three-body charge separation. A further possible path is (b) secondary decay in competition – where each of the separated cations releases a neutral fragment, recognizable experimentally as a hexagonal pattern with the horizontal and vertical edges dependent on the momenta of the neutrals' ejection, while the slopes of the oblique edges depend on the mass of the cations.

As the PEPIICO technique yields more insight into the fragmentation dynamics of dications, it has been successfully applied in investigating a large range of small molecules, e.g. SF₆ [45], CO₂, CS₂, NO₂, SO₂, CH₃I [46], CF₄ [51][54], big inorganic [55] and organic molecules [56][57] as well as to the decay of charged chalcogene [58][59] and rare gas clusters [60][61].

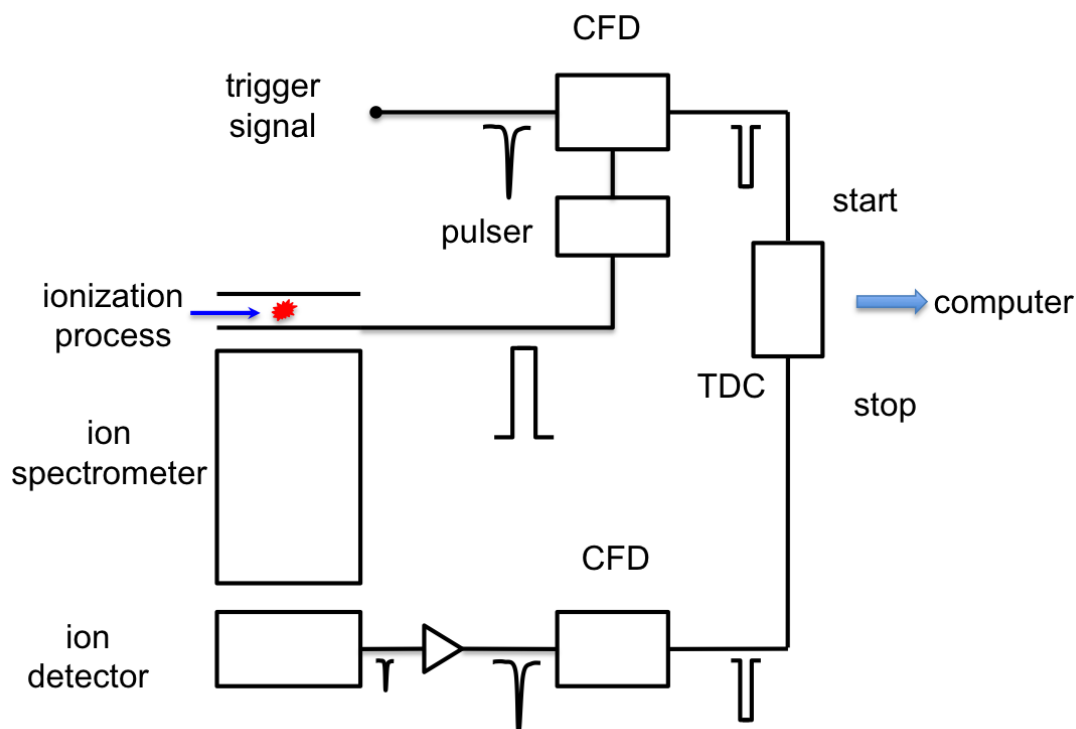

Figure 2. Schematics of a trigger-ion-ion coincidence experimental setup (see text for details).

In particular, it is possible to vary this set-up such that two ionic fragments, but not the (photo)electron are recorded, as schematically shown in Figure 2. Here a measurement is started by a trigger signal (which can be a beam chopper [62][63][64], a laser trigger, a photodiode or beam dump signal [65][66][67], a beam buncher etc.), which sets the t_0 , i.e. the time at which the ionization process takes place. Simultaneously, the trigger actuates a pulser to extract the ions from the interaction region of the ion spectrometer towards the detector. The arrival time of the fragments at the ion detector are used (after discrimination by the CFD) to stop the measurement.

As the two fragments are emerging from the same ionization process, by plotting the arrival time of one ionic fragment versus the flight time of the other ion, one obtains the correlation map of the two fragments, while the possible features that can occur are as described in the previous paragraphs.

2.4. Ion, neutral coincidence

Yet another technique to gather information on the fragmentation pathway subsequent to ionization is the recording of both the charged and the neutral fragments emerging. This ion, neutral coincidence approach bears, compared to all coincidence techniques mentioned above, the unique advantage that the uncharged moiety in the fragmentation process is not discarded but recorded by a separate detector. In other words, this method carries the potential of offering a more complete picture of a fragmentation pathway involving neutral particles than any of the other spectroscopic tools.

As the neutral particles are considerably more difficult to steer than their charged counterparts, the method of handling such an experiment can be two fold: i) the product of the ionization process is accelerated towards a detector by means of an electric lens, in the assumption that it will fragment subsequent to the extraction, and, based on the difference in the flight time of the end-products, it is discriminated between the charged and neutral particles (as reported by Martin *et al.* in ref. [67]); ii) the experimental setup is fitted with a separate detector for the uncharged moieties, along the flight path of the parent ion, and one or two detectors, along an electric-field deflected path, for the electrically charged fragments (as shown in [68][69][70][71][72][73]). The latter approach has the advantage that it is well suited for investigating decay processes in which the emission of neutrals takes place in the first step of the fission. As conventional secondary electron multipliers are not sensitive to slow neutral particles, experiments cited above are carried out on an ion beam of several keV kinetic energy.

2.5. Electron, electron coincidence

By definition, an ionization process involves the emission of electrons as a consequence of energy being transferred to the system (atom, molecule, cluster etc.). In the simplest case, a sufficient amount of energy is transferred to the system to have an electron overcome the potential barrier (called ionization potential, IP) that keeps it bound to the parent atom. However, if the energy pumped into the system is sufficient, a second electron can be released. The two electrons can be emitted from the same, or different electronic shells. As the emission is from the same ionization process, investigating the phenomenon yields valuable information on the correlation of the two electrons. As pointed out by Lablanquie *et al.* [74] a great deal of experiments investigating the correlation of the electrons in atoms and molecules have been performed in the early years, since the first *electron, electron coincidence* experiments [75] in the field have been done [76][77][78][79][80][81][82][83][84][85][86]. Although the earliest study was on bulk copper [75], the majority of the subsequent research has focused on gaseous samples. In the last

years, however, applying the coincidence technique has proven viable also for investigations on solid samples, as will be shown further.

One of the mechanisms that can be investigated by coincidence techniques is the valence multiple ionization, when two or more electrons from a valence shell are promoted into the vacuum level as an effect of one quantum of energy impinging on the atom. By using coincidence methods, one can, for instance, determine the angular patterns of the photo-double ionization in atoms [85] and molecules [84], only possible to infer when the two *correlated* electrons are recorded at the same time. Further on, a great deal of insight into the mechanism of photo-double ionization of small molecules could be gained by employing the electron-electron coincidence technique, as shown by several authors [86][87][88].

A special case of this technique is the so-called threshold photoelectron coincidence spectroscopy (in short, TPEsCO) [89][90][91]. Experimental work in the immediate vicinity of the ionization threshold is, as emphasized by Krässig and Schmidt [91], of particular interest also from the theoretical point of view as it is bridging the gap between the classical and the quantum mechanical approaches of the direct photo-double ionization in the outer shell of atomic species. TPEsCO gained momentum in following years in the scientific community, and was successfully employed for addressing a variety of issues, e.g. the double-photoionization of small molecules [92][93][94], the observation of satellites of rare gases [95][96] or spectroscopic investigations on doubly-charged ion states [97][98][99][100][101][102][103][104].

Although successful, a great deal of the experiments performed in the earlier days employed electron spectrometers with a good energy resolution but with a rather limited collection efficiency (see, e.g. the work of Jensen and coworkers [105][106][107], Bartynski *et al.* [108], V. Schmidt *et al.* [77][82] and Price and Eland [109][110][111][112][113]). However, in several of the aforementioned references, the authors repeatedly point out that the coincident event count rate achieved is rather low (of the order of $0.025 - 0.25 \text{ s}^{-1}$), which hinders the recording of the complete information on the ionization process (i.e. a three-dimensional map, with the abscissa and the ordinate being the kinetic energies of the two electron, and the intensity plotted on the third axis [114]) within a reasonable amount of measurement time.

In two elaborate reports, Jensen *et al.* [107] and Calicchia and collaborators [115] address the feasibility of applying electron, electron coincidence spectroscopy in experiments at synchrotron radiation storage rings and discuss the limiting factors of such experiments. Nevertheless, the discussion in the reports can be generalized also to experiments performed using other ionizing sources (gas discharge lamps, electron beam, lasers etc). Due to their extensiveness, we would like to point the reader to the original manuscripts, and will refrain herein to synthesizing the conclusions of the authors:

- i) if the experiment makes use of two detectors, for recording the two ejected electrons, it is of crucial importance to have the interaction region volumes imaged by the detectors overlapping as much as possible;
- ii) the time required for performing a coincidence experiment is directly proportional to the square of the desired signal-to-noise ratio, and inversely proportional to the count rate;
- iii) the true coincidence count rate (i.e., the count rate of the useful coincident events) is directly proportional to the incident ionizing radiation flux, while at the same time, the accidental coincidence count rate (i.e., the count rate of the noise) is proportional to the square of the incident ionizing radiation flux; in other words, at low flux, the noise level will be negligible, whereas, on increasing the ionizing beam intensity, the accidental coincidence rate will gain in importance, leading to a saturation of the effective useful count rate (typically, at an order of few thousand counts/second), thus rendering additional flux unusable. For Poisson-distributed events, it can be shown that the signal-to-noise ratio is independent of the incident flux;
- iv) fundamental parameters influencing the effective count rate (single channel count rate of several kHz lead to effective count rates of 0.5-1 Hz) are the timing resolution and the spectrometer detection efficiency; related to this condition, one should bear in mind

that, typically, increasing the efficiency of an analyzer is done at the cost of energy and/or angular resolution.

- v) coincidence experiments that use a pulsed excitation source benefit from a high repetition rate of this source, as long as the inverse rate is lower than the required coincidence window.

Using a particular as an example, a useful discussion of these aspects is also in [184].

With the employment of so-called “magnetic bottle” type spectrometers for electron, electron coincidence spectroscopy by Eland et al [116] the technique gained new momentum (see, e.g. [117][118][119][120][121][122][123][124]). The main advantage in using this sort of spectrometers is the (4π) collection efficiency of the spectrometer and a good detection efficiency also at very low kinetic energies (< 1 eV). In principle, a “magnetic bottle” type spectrometer is a time-of-flight electron analyzer, which makes use of two magnetic field regions for improving the collection efficiency and to preserve the full kinetic energy range probed. The first magnetic field region is strong and inhomogeneous, and covers the interaction region of the spectrometer, with the purpose of collecting the emitted electrons and to guide them towards the second magnetic field region. The latter, is a homogeneous, weak field, which guides the electron along a drift tube towards the detector. We would like to point out that, in the first report on an electron spectrometer using the “magnetic bottleneck effect” by Beamson and coworkers [125], the authors made use of superconducting coils. Few years later, Kruit and Read [126] developed a similar spectrometer suited for time-of-flight measurements based on electromagnets, followed by a further refinement by Tsuboi et al. using permanent magnets for creation of the inhomogeneous magnetic field region [127]. Further developments have led to the improvement of the energy resolution, making thus the method suitable not only for electron, electron coincidence spectroscopy, but also for electron spectroscopy on mass selected clusters [128][129] and cluster anions [130][131], for Penning ionization electron spectroscopy [132] or even vibrational spectroscopy (with 6 meV FWHM energy resolution) on clusters [133].

In the past decade, “magnetic bottle” type electron spectrometers have not only been used for electron, electron coincidence spectroscopy, but also for electron, ion coincident detection, in conjunction with time-of-flight mass spectrometers [134][135]. In more recent refinements, the spectrometer accommodates also extraction electrodes [136] or a further inner flight tube [137], allowing to perform PEPICO experiments using the same detector.

However, as pointed out previously, the application of the electron, electron coincidence approach is not only limited to gas phase samples. A wide variety of experiments have been performed on solids, ranging from determining the fraction of the surface plasmons contributing to secondary electron emission after electron bombardment [138] to investigations of the electron pair emission from metals [139][140][141][142][143][144], insulators [145] and even superconductors [146].

Electron correlation can lead to the ejection of two electrons after a single absorption or impact event, also if they do not originate from the same site, and are not even connected by strong chemical bonding. This has been observed for liquids (connected by hydrogen bonding) and rare gas clusters (bound by van der Waals forces). In this so-called Interatomic or Intermolecular Coulombic Decay [147][148][149], a core or inner valence vacancy is created in a primary process, and subsequently excess energy leads to ionization at another site. When the energy transfer from the one to the other atom (molecule) proceeds by exchange of a ‘virtual photon’, one speaks of interatomic (intermolecular) coulombic decay (ICD) [147]. Although proven about a decade ago [148], ICD has spawned extensive experimental work by means of electron, electron coincidence spectroscopy on various systems [149], ranging from dimers and small clusters [150][151][152] to large monoatomic [153][154] and mixed rare gas agglomerates [155][156]. Of particular interest are the recent studies on water clusters [157][158] which indicate that low kinetic energy electrons produced during ICD could be one of the responsible causes for DNA strand breaking in living tissue [159].

A different autoionization process is the so-called electron transfer mediated decay (ETMD) [160], where after the primary inner-valence (*iv*) ionization, an electron from an outer-valence

(*ov*) shell of a neighboring atom fills the hole in the *iv* band, with the excess energy being released by the emission of a second electron (ETMD electron) from the atom ‘donating’ the *ov* electron, or from a (third) neighboring atom (reference ETMD). As in a number of systems ETMD is quenched by ICD processes, the first experimental proof of ETMD has only recently been achieved by recording the ETMD electron and the photoelectron in coincidence [161][162], using a magnetic bottle electron spectrometer [163].

In a recent series of experiments performed at free electron laser (FEL) facilities, an alternative approach to conventional coincidence spectroscopy has proven to be the so-called covariance mapping. This method, introduced to the field of photoionization by Frasinski and co-workers in the late 80’s [164], bears the advantage that it can cope with shot-to-shot variation in the intensity of the FELs. A comprehensive comparison between the two approaches is given by Zhaunerchik et al. [165], where the authors emphasize advantages of using the covariance mapping technique to overcome the limitations of the conventional coincidence method. A condition required to hold for the analysis of coincidence spectra discussed so far is that the average number of ionization events per cycle is smaller than unity. If count rates exceed this limit substantially, several random coincidences will be recorded in every cycle, and cannot be separated from the true coincidences by a simple subtraction. In the covariance mapping approach one can still extract useful information from the dataset by subtracting the uncorrelated product of the two 1D spectra (the ordinate and the abscissa) of the coincidence map. In other words, by using this technique, one is no longer limited to using a low ionizing radiation flux (i.e. low individual count rates for the coincidence channels), which has the effect of decreased measuring time for the same amount of true coincident events.

So far, covariance mapping has proven to be a viable complementary tool to conventional spectroscopic methods in studies of the formation of hollow atoms [166] or on the photoelectron distribution in multi-photon ionization of atoms and molecules [167]; further on, the technique has spawned already theoretical work, e.g. on the kinematics of autoionization processes [168].

2.6. Photoelectron – Auger electron coincidence

In ionization processes of an atom or molecule, when the ionizing energy is large enough to remove an inner-shell electron, the system can de-excite by having one of the electrons from a higher electronic shell filling the vacancy. The excess energy can be released either by the emission of a photon or by the ejection of a further electron. The latter electron bears the name of Auger electron [169], and since its kinetic energy approximately equals to the energy difference between the inner shell energy and its (original) outer shell energy, is element specific. Due to this property, Auger electron spectroscopy is a widely used tool for determining material composition, e.g. in surface analysis [170].

Quite generally, however, the Auger electron energy spectrum is determined by convoluting the spectral signatures of the intermediate (mono-cationic) states with all final (dicationic) states involved. While in isolated atoms only different electronic states play a role, in molecules the vibrational profiles of each state must be taken into account [171][172], and in bulk condensed matter also the valence bandwidth and -shape may be reflected in the outcome of the experiment [173]. Extracting relevant information from conventional Auger spectra can therefore be a tedious task, as the number of mixed states can be large. However, by recording both the Auger electron and the photoelectron emitted in the decay process, a more detailed view of the process can be gained. By this approach (photoelectron, Auger electron coincidence spectroscopy) one can identify the individual intermediate states and can unambiguously link them to the pertaining dicationic states.

The technique found applications also in surface science, allowing to discriminate between the ‘normal’ Auger decay and a ‘Coster-Kronig preceded’ Auger decay processes in a study of the Cu $L_{23}M_{45}M_{45}$ transitions. Moreover, the authors conclude on an increased surface sensitivity of the coincidence method as compared to the conventional spectroscopic approach [75]. More recent studies on an ion-bombardment amorphized Si(100) surface have

lead to a quantitative determination of the average emission depth of both the Auger and the photoelectrons [174]. Further experimental work of Stefani *et al.* [175] shows that by using the angular resolved Auger electron, photoelectron coincidence spectroscopy approach one can investigate the core ionization mechanism in solids with l and m_l quantum numbers selectivity, i.e. one can uniquely correlate the dicationic final states magnetic substates to the monocationic magnetic sublevels.

In a groundbreaking experiment on gaseous Xe, Viefhaus *et al.* [78] have shown that, by recording the photoelectron and the Auger electron in coincidence it is possible to filter out very weak components in the Auger energy spectra. Further on, at least for stable (dicationic) Auger final states, the achievable energy resolution of the experiment is not limited by the lifetime of the decaying inner-shell hole, as confirmed also by the results of Lablanquie *et al.* [79].

Further on, by this technique one is enabled to measure e.g. the lowest triple ionization threshold in molecules, as shown by Eland and co-workers by investigations on methane [176] and carbon disulfide [177]. A further breakthrough made possible by means of electron, electron coincidence was the evidence for double core-hole state in small molecules (CH_4 and NH_3), where the double vacancies are located in the $1s$ shells [178]. Moreover, the method was successfully used to investigate the effect of the local chemical environment on Auger spectra, revealing that, in $\text{C}_4\text{H}_5\text{F}_3\text{O}_2$, all Auger decays tend to populate localized dicationic states, where the holes are located either at the same or at nearest neighboring F atoms [179]. Most photoelectron, Auger electron coincidence experiments have been performed on gaseous samples, ranging from identifying the spectroscopic signatures of the shake-up and shake-off satellites involved in the Auger process [180], to observations of the decay of inner-shell holes in ions [181] or to probing the Auger decay in dissociative molecular dications by analyzing the Auger energy spectra as recorded for the individual vibrational levels of the photoelectron [182][183][184][185][186].

In a recent study using this experimental method, the nuclear dynamics during the Auger decay process was addressed, as observed in the decay of the CF_4 molecule after F $1s$ ionization [187]. In the CF_4 molecule, both the intermediate and the final states are of dissociative character, and it was shown that the Auger electron energy spectra carry the signature of the conformation of the decaying molecule.

In a complementary study, we have investigated the Auger decay in the CH_3F molecule, after F $1s$ ionization by photoelectron, Auger electron coincidence spectroscopy. The central part of Figure 3 shows the coincident Auger electron vs. photoelectron spectrum of CH_3F as a color coded map, as recorded after ionization with $h\nu = 702$ eV energy photons (the F $1s$ ionization energy of CH_3F is 692.4 eV [188][189]). On summing up the events along the photoelectron energy axis one obtains the photoelectron spectrum, as plotted in the upper panel, which consists of a broad peak, which does not exhibit any vibrational structure. The Auger energy spectrum, displayed in the right-hand side panel is obtained by projecting the coincidence map on the Auger energy axis. The notations in the Auger spectrum (B1 to B8) follow the earlier assignment of Moddeman [190]. The coincidence map unambiguously shows that, for the same Auger electron energy (i.e. same dicationic final state) regions with different intensity occur.

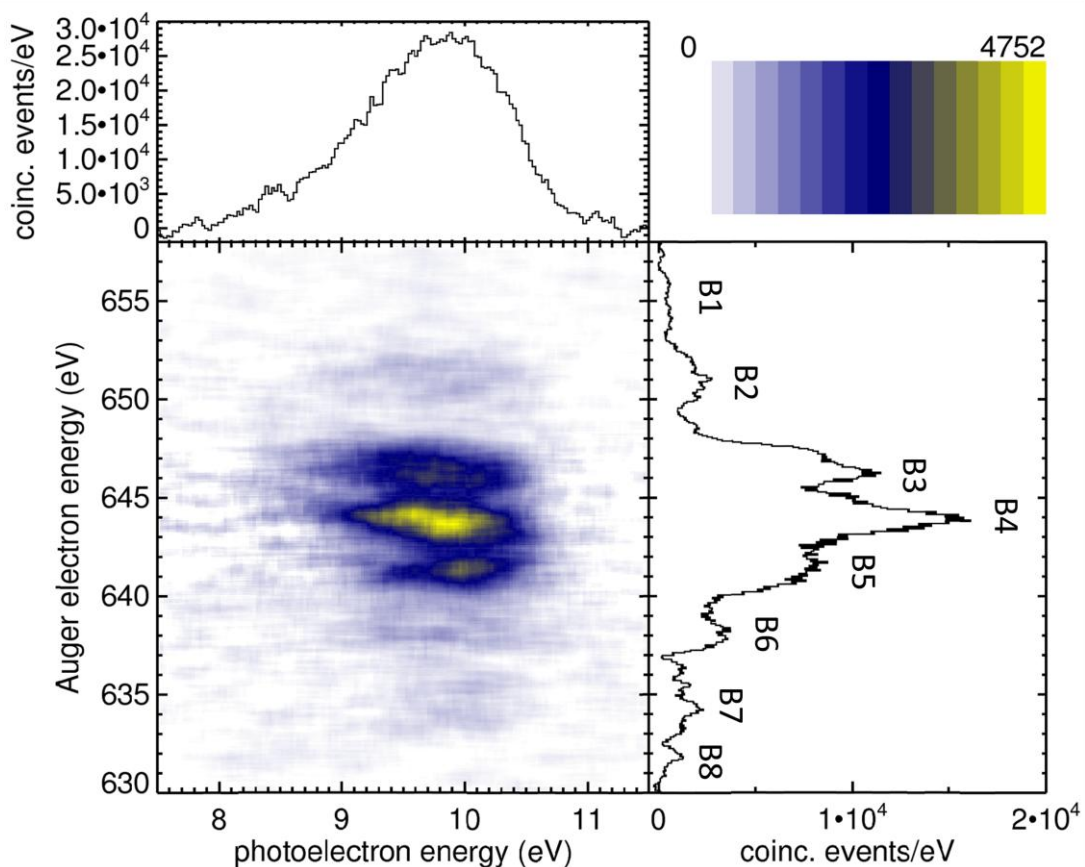

Figure 3. Center: Auger electron - photoelectron coincident spectrum of CH_3F after ionization above the F 1s edge, after excitation by $h\nu = 702$ eV. Top-left and bottom-right: Photoelectron spectrum and Auger electron spectrum obtained by summation over all energies of the other electron. These correspond (approximately) to the non-coincident photoelectron and Auger electron spectra of CH_3F as recorded by conventional electron spectroscopy (see text for details).

In Figure 4 the green curve shows the integral Auger spectrum of CH_3F as recorded in coincidence with photoelectrons, after ionization above the F 1s ionization threshold. Projecting the coincidence maps regions as marked by the colored squares in the inset of Fig. 4, onto the Auger energy axis, one obtains the black, red and blue curves. The division of the coincidence maps into the three regions, depends on the kinetic energy of the photoelectron (low kinetic energy flank, blue, medium fast electrons, red and fast photoelectrons, black). By doing so one can follow the influence of the intermediate potential curve on the Auger electron energy spectrum.

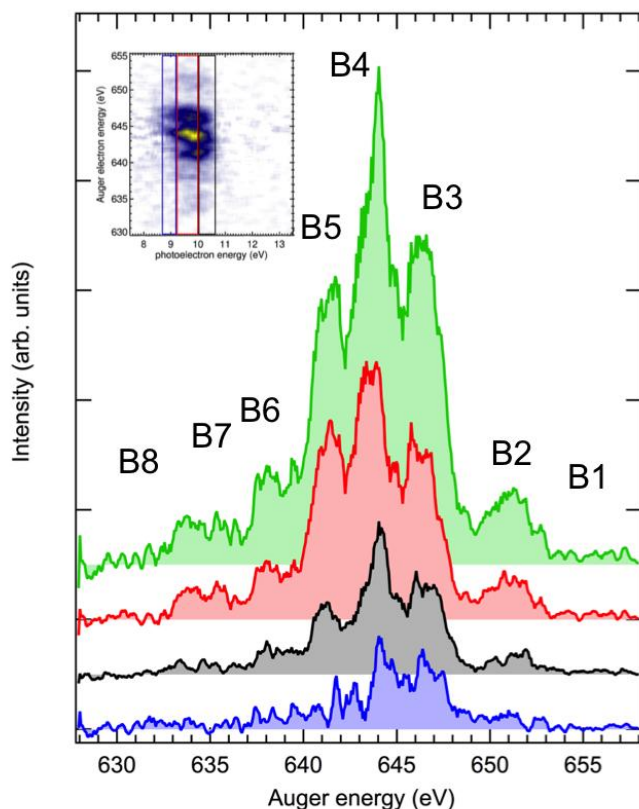

Figure 4. Auger spectra of CH_3F recorded in coincidence with photoelectrons, as obtained by projecting the marked regions in the inset on the Auger energy axis. Population differences between the red and the black trace in peaks B3-B5 are significant (see text for details).

It is clear that the Auger decay leading to the occurrence of the low kinetic energy photoelectrons (the blue curve) does not participate in the population of the B1, B6, B7 and B8 (as denoted in ref. [190]) Auger final states. By contrast, the Auger cascade leading to the emergence of the fast electrons (black curve) is involved in the population of all Auger states, but B7 and B8. We can conclude, thus, that these states (B7 and B8) gain intensity only through Auger decay involving the ejection of a medium fast photoelectron.

This variation in the propensity of the specific final state to be populated depending on the kinetic energy of the photoelectron speaks for an internal factor influencing the decay, such as the dynamics of the molecule after the primary ionization. In other words, if the emission of the Auger electron would take place after the molecule dissociated, no preferential propensity of the final state should be observed, as the molecule would decay atomic-like – which is obviously not the case here.

Our results on the CH_3F , corroborated with the findings in [187] indicate that, at least for the case of fluorinated molecules, one cannot rule out that the one-step interpretation of Auger decay might need revision. Specifically, we show evidence that *internal* factors influence the decay of the monocationic intermediate levels to the final doubly-charged states.

2.7. COLTRIMS

A powerful coincidence technique is the so-called COLd Target Recoil Ion Momentum Spectroscopy (COLTRIMS) [191]. By the virtue of its complexity and flexibility, and due to the multitude of experiments existing, which employ this particular method, it needs to be addressed in a separate paragraph. This approach aims at providing a kinematically complete (i.e. inferring the momenta of all involved moieties) picture of a decay involving three- and

more particles. However, only a very brief overview of the technique will be given in this manuscript, as elaborate and detailed reviews about the method and the experiments using it can be found elsewhere [191][192][193] (and references therein).

For the detection of charged particles, COLTRIMS combines an ion spectrometer and an electron spectrometer, both of which consist of a system of ring electrodes, allowing for guiding and focusing of the charged particles, as schematically shown in Fig. 5. Further on, for a more efficient collection and guidance of the electrons, COLTRIMS makes use of a superimposed solenoidal magnetic field, parallel to the electric field lines [194]. This has the effect that the electron will precess around the magnetic field lines, allowing for an improved energy resolution (5 meV) and high collection efficiency (4π for electrons with a kinetic energy smaller than 30 eV). The spectrometer is fitted with large detectors using a fast, position sensitive readout, on both sides. Delay-line anodes are mostly used in practice. This enables the read-out of the impact position of the particle on the detector, allowing thus the determination of the momentum components parallel and perpendicular to the detector surface.

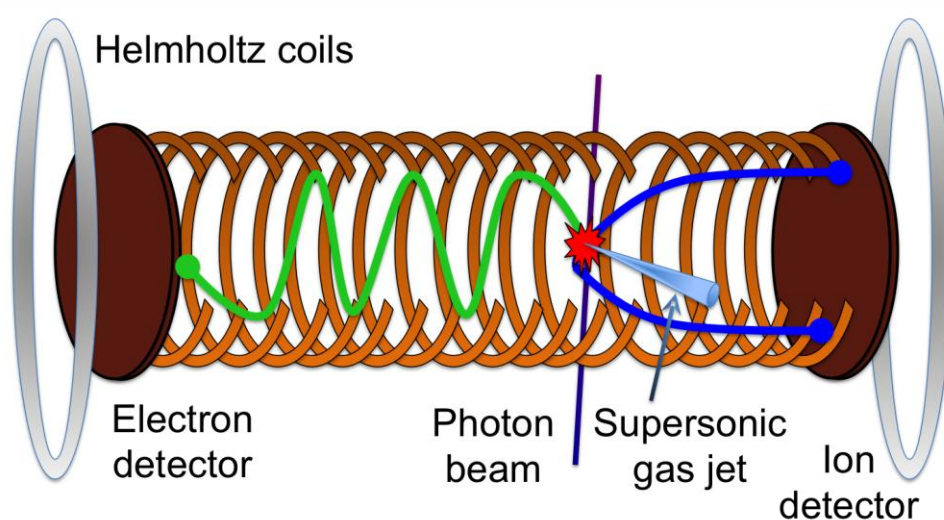

Figure 5. Schematics of a COLTRIMS experiment (see text for details).

Working around the limitations in momentum resolution imposed by the internal ionic momentum, the technique makes use of cold supersonic gas-jet targets, which leads to an ultimate resolution of 0.05 – 0.2 a.u. for the recoil ion, while confining the 4π collection efficiency [191].

As in COLTRIMS all particles involved in the fragmentation are collected (‘reaction microscope’[191]), a variety of coincidence experiments are enabled, ranging from electron-ion- and ion-ion- to electron-electron-ion-ion coincidence experiments. The technique has been applied so far to a broad range of studies, including (but not limited to) on fragmentation processes on small molecules[195][196], circular dichroism in molecules[197][198], ICD and Auger decay [150][158][199][200], FEL-induced multiple ionization experiments [201][202] or the time evolution of autoionization processes [203][204].

3. Perspectives of the coincidence techniques

Currently, in photoelectron, Auger electron coincidence spectroscopy experiments an energy resolution of below 150 meV can readily be achieved, in gas phase experiments [184][186]. However, one of the limiting factors in the Auger electron channel is the limited acceptance of the spectrometer used for this species. With the advances in the development of electron

spectrometers in the past years, new analyzers with improved collection efficiency while still keeping meV resolving power have emerged [186][205][206]. With their implementation in coincidence spectroscopy enabled experimental stations, the vision of resolving Auger decay processes with an energy resolution below the natural broadening of the spectral features should be a goal not too far off reach.

Moreover, the use of high energy resolution spectrometers, combined in an experiment capable of resolving features a few meV apart might prove to be a suitable instrument to address important issues in condensed matter physics, such as the decay of quasi-particles [207][208][209].

Current experiments on liquid jet samples [210][211] tend to suffer from a rather pronounced background of slow electron, resulting from intermolecular electron scattering (inelastic collisions). However, based on the observation that the signal-to-background contrast is improved when using a coincidence spectroscopic technique, we believe that this approach would be a feasible alternative to conventional spectroscopy. This could help establish the micro-jet technique as the path of choice for investigations on biological samples and electrochemically relevant substances.

FEL based radiation sources allow to enter a new era of X-ray photon, matter interaction, and coincidence methods had their share in its investigation (see references above). In view of the requirement of a low event rate and the benefits of a high event rate of the ionization source, careful scrutiny with respect to the feasibility of any coincidence experiment is advised. One field where it has potential merits is the investigation of very thin targets, such as ion beams [212] or electrospray sources [213]. Moreover, if e.g. the directional correlation between different particles is of interest, currently there is no alternative to particle, particle coincidence techniques. All free electron laser facilities have dedicated multi-purpose chambers for atomic and molecular physics, fitted with several spectrometers, which points to a very bright future for the technique.

Acknowledgements

The authors would like to thank the Helmholtz Zentrum Berlin for the allocation of beam time. Further on, the authors would like to thank all colleagues with whom they have worked on the CH₃F project (T. Lischke, M. Förstel, M. Mucke, R. Püttner, V. Sekushin). Fruitful discussions with W. Eberhardt, S. Svensson, C. Lupulescu and R. Ovsyannikov are gratefully acknowledged. Funding via the DFG Forschergruppe 1789 is gratefully acknowledged.

References

- [1] B. Brehm and E. v. Puttkammer, *Z. Naturforsch. A* **22** (1967) 8.
- [2] E. v. Puttkammer, *Z. Naturforsch. A* **25** (1970) 1062.
- [3] J. H. D. Eland, *Int. J. Mass. Spectrom. Ion Phys.* **8** (1972) 143.
- [4] C. J. Danby and J. H. D. Eland, *Int. J. Mass. Spectrom. Ion Phys.* **8** (1972) 153.
- [5] J. H. D. Eland, *Int. J. Mass. Spectrom. Ion Phys.* **9** (1972) 397.
- [6] G. R. Branton and C. E. Brion, *J. Electron. Spectrosc. Relat. Phenom.* **3** (1974) 123.
- [7] M. Gellender and A. D. Baker, *Int. J. Mass. Spectrom.* **17** (1975) 1.
- [8] W. C. Wiley and I. H. McLaren, *Rev. Sci. Instrum.* **26** (1955) 1150.
- [9] J. L. Franklin, P. M. Hierl and A. Whan, *J. Chem. Phys.* **47** (1967) 3148.
- [10] D. M. Hanson, D. A. Lapiano-Smith, K. Lee, C. I. Ma and D. Y. Kim, *Chem. Phys.* **162** (1992) 439.

- [11] J. J. Neville, T. Tyliczszak and A. P. Hitchcock, *J. Electron. Spectrosc. Relat. Phenom.* **101-103** (1999) 119.
- [12] J. J. Neville, T. Tyliczszak, A. P. Hitchcock, A. Jürgensen and R. G. Cavell, *Chem. Phys. Lett.* **300** (1999) 451.
- [13] T.A. Field, F. Dulieu, J.-H. Fillion, S. Douin, J.-L. Lemaire, and S. Leach, *Chem. Phys.* **250** (1999) 81.
- [14] T. Hayakawa, K. Nagaya, I. Yamamoto, Y. Ohmasa, M. Yao and M. Nomura, *J. Phys. Soc. Jap.* **69** (2000) 2039.
- [15] T. Hayakawa, K. Nagaya, K. Hamada, Y. Ohmasa and M. Yao, *J. Phys. Soc. Jap.* **69** (2000) 2850.
- [16] J. Geiger and E. Rühl, *Int. J. Mass Spectrom.* **220** (2002) 99.
- [17] R. Feng, R. G. Cavell and A. P. Hitchcock, *J. Electron. Spectrosc. Relat. Phenom.* **144-147** (2005) 231.
- [18] H. Murakami, K. Nagaya, Y. Ohmasa, H. Iwayama and M. Yao, *J. Chem. Phys.* **126** (2007) 054306.
- [19] J. H. D. Eland, *Meas. Sci. Technol.* **4** (1993) 1522.
- [20] R. I. Hall, K. Ellis, A. McConkey, G. Dawber, L. Avaldi, M. A. MacDonald and G. C. King, *J. Phys. B: Mol. Opt. Phys.*, **25** (1992) 377.
- [21] G. Prümper, K. Ueda, Y. Tamenori, M. Kitajima, N. Kuze, H. Tanaka, C. Makochekanwa, M. Hoshino, and M. Oura, *Phys. Rev. A* **71** (2005) 052704.
- [22] G. A. Garcia, H. Soldi-Lose and L. Nahon, *Rev. Sci. Instrum.* **80** (2009) 023102.
- [23] X. J. Liu, G. Prümper, E. Kukk, R. Sankari, M. Hoshino, C. Makochekanwa, M. Kitajima, H. Tanaka, H. Yoshida, Y. Tamenori and K. Ueda, *Phys. Rev. A* **72** (2005) 042704.
- [24] G. Prümper, H. Fuzukawa, T. Lischke and K. Ueda, *Rev. Sci. Instrum.* **78** (2007) 083104.
- [25] P. A. Hatherly, D. M. Smith and R. P. Tuckett, *Z. Phys. Chem.* **195** (1996) 97.
- [26] M. A. Parkes, S. Ali, R. P. Tuckett, V. A. Mikhailov and C. A. Mayhew, *Phys. Chem. Chem. Phys.* **8** (2006) 3643.
- [27] K. Kooser, D. T. Ha, E. Itälä, J. Laksman, S. Urpelainen and E. Kukk, *J. Chem. Phys.* **137** (2012) 044304.
- [28] U. Alkemper and F. von Busch, *J. Electron Spectros. Relat. Phenomena* **93**, 115 (1998).
- [29] W. Eberhardt, E. W. Plummer, I. -W. Lyo, R. Carr and W. K. Ford, *Phys. Rev. Lett.* **58** (1987) 207.
- [30] C. Miron and P. Morin, *Nucl. Instrum. Meth. Phys. Res. Sect. A* **601** (2009) 66.
- [31] R. Murphy and W. Eberhardt, *J. Chem. Phys.* **89** (1988) 4054.
- [32] M. Neeb, J. -E. Rubensson, M. Biermann and W. Eberhardt, *J. Phys. B: At. Mol. Opt. Phys.* **29** (1996) 4381.
- [33] D.M. Hanson, C.I. Ma, K. Lee, D. Lapiano-Smith, and D.Y. Kim, *J. Chem. Phys.* **93**, 9200 (1990).
- [34] E. Kukk, G. Prümper, R. Sankari, M. Hoshino, C. Makochekanwa, M. Kitajima, H. Tanaka, H. Yoshida, Y. Tamenori, E. Rachlew, and K. Ueda, *J. Phys. B At. Mol. Opt. Phys.* **40**, 3677 (2007).
- [35] G. Dujardin, S. Leach, O. Dutuit, P.-M. Guyon and M. Richard-Viard, *Chem. Phys.* **88** (1984) 339.
- [36] K. E. McCulloh, T. E. Sharp and H. M. Rosenstock, *J. Chem. Phys.* **42** (1965) 3501.
- [37] B. P. Tsai and J. H. D. Eland, *Int. J. Mass Spectrom. Ion Phys.* **36** (1980) 143.
- [38] K. E. McCulloh and H. M. Rosenstock, *J. Chem. Phys.* **48** (1968) 2084.

- [39] B. H. Boo and I. Koyano, *J. Kor. Phys. Soc.* **40** (2002) 826.
- [40] T. Ibuki, A. Hiraya, T. N. Olney and C. E. Brion, *Chem. Phys.* **203** (1996) 359.
- [41] E. Rühl and R. Flesch, *J. Chem. Phys.* **121** (2004) 5322.
- [42] T. Masuoka and I. Koyano, *J. Chem. Phys.* **95** (1991) 909.
- [43] E. Rühl, C. Schmale, H. W. Jochims, E. Biller, M. Simon and H. Baumgärtel, *J. Chem. Phys.* **95** (1991) 6544.
- [44] E. Rühl, C. Schmale, H. C. Schmelz and H. Baumgärtel, *Chem. Phys. Lett.* **191** (1992) 430.
- [45] L. J. Frasinski, M. Stankiewicz, K. J. Randall, P. A. Hatherly, and K. Codling, *J. Phys. B: At. Mol. Opt. Phys.*, **19** (1986) L819.
- [46] J. H. D. Eland, *Mol. Phys.* **61** (1987) 725.
- [47] P. A. Hatherly, M. Stankiewicz, L. J. Frasinski, K. Codling, and M. A. MacDonald, *Chem Phys. Lett.* **159** (1989) 355.
- [48] M. Stankiewicz, P. A. Hatherly, L. J. Frasinski, K. Codling, and D. M. P. Holland, *J. Phys. B: At. Mol. Opt. Phys.* **22** (1989) 21.
- [49] K. Codling, L. J. Frasinski, P. A. Hatherly and M. Stankiewicz, *Phys. Scripta* **41** (1990) 433.
- [50] J. H. D. Eland, *Laser Chem.* **11** (1991) 259.
- [51] K. Codling, L. J. Frasinski, P. A. Hatherly, M. Stankiewicz, and F. P. Larkins, *J. Phys. B: At. Mol. Opt. Phys.* **24** (1991) 951.
- [52] M. Lavollée and H. Bergeron, *J. Phys. B: At. Mol. Opt. Phys.* **25** (1992) 3101.
- [53] M. Simon, T. Lebrun, R. Martins, G. G. B. de Souza, I. Nenner, M. Lavollee, and P. Morin *J. Phys. Chem.* **97** (1993) 5228.
- [54] L. Mi, C. R. Sporleder and R. A. Bonham, *Chem. Phys. Lett.*, **251** (1996) 252.
- [55] T. Ibuki, Y. Shimada, R. Hashimoto, S. Nagaoka, M. Hino, K. Okada, I. H. Suzuki, Y. Morishita and Y. Tamenori, *Chem. Phys.* **314** (2005) 119.
- [56] E. Rühl, A. P. Hitchcock, J. D. Bozek, T. Tylliszczak, A. L. D. Kilcoyne, D. N. McIlroy, A. Knop-Gericke, and P. A. Dowben, *Phys. Stat. Sol. B* **246** (2009) 244313.
- [57] J. Liu, E. Rühl, A.P. Hitchcock, D.N. McIlroy, J.D. Bozek, T. Tylliszczak, A. Knop-Gericke, N.M. Boag und P. A. Dowben, *Z. Phys. Chem.* **228** (2014) 421.
- [58] C. M. Teodorescu, D. Gravel and E. Rühl, *J. Chem. Phys* **109** (1998) 9280.
- [59] C. M. Teodorescu, D. Grvel, J. Choi, D. Pugmire, P. A. Dowben, N. Fominykh, A. A. Pavlychev and E. Rühl, *J. Electron. Spectrosc. Relat. Phenom.* **101** (1999) 193.
- [60] E. Rühl, C. Heinzl, H. Baumgärtel, M. Lavollee and P. Morin, *Z. Phys. D* **31** (1994) 245
- [61] E. Rühl, *Int. J. Mass. Spectrom.* **229** (2003) 117.
- [62] T. Schlathölter, F. Alvarado, S. Bari and R. Hoekstra, *Phys. Scr.* **73** (2006) C113.
- [63] F. Alvarado, S. Bari, R. Hoekstra and T. Schlathölter, *J. Chem. Phys.* **127** (2007) 034301.
- [64] T. Arion, R. Flesch, T. Schlathölter, F. Alvarado, R. Hoekstra, R. Morgenstern, E. Rühl, *Int. J. Mass Spectrom.* **277** (2008) 197.
- [65] S. Martin, L. Chen, R. Brédy, J. Bernard, M. C. Buchet-Poulizac, A. Allouche and J. Désesquelles, *Phys. Rev. A* **66** (2002) 063201.
- [66] L. Chen, B. Wei, J. Bernard, R. Brédy and S. Martin, *Phys. Rev. A* **71** (2005) 043201.
- [67] S. Martin, R. Brédy, A. R. Allouche, J. Bernard, A. Salmoun, B. Li and L. Chen, *Phys. Rev. A* **77** (2008) 062513.
- [68] H. B. Pedersen, S. Altevogt, B. Jordon-Thaden, O. Heber, M. L. Rappaport,

- D. Schwalm, J. Ullrich, D. Zajfman, R. Treusch, N. Guerassimova, M. Martins, J.-T. Hoefl, M. Wellhöfer and A. Wolf, *Phys. Rev. Lett.* **98** (2007) 223202.
- [69] H. B. Pedersen, S. Altevogt, B. Jordon-Thaden, O. Heber, L. Lammich, M. L. Rappaport, D. Schwalm, J. Ullrich, D. Zajfman, R. Treusch, N. Guerassimova, M. Martins, and A. Wolf, *Phys. Rev. A* **80** (2009) 012707.
- [70] L. Lammich, C. Domesle, B. Jordon-Thaden, M. Förstel, T. Arion, T. Lischke, O. Heber, S. Klumpp, M. Martins, N. Guerassimova, R. Treusch, J. Ullrich, U. Hergenhahn, H. B. Pedersen and A. Wolf, *Phys. Rev. Lett.* **105** (2010) 253003.
- [71] H. B. Pedersen, C. Domesle, L. Lammich, S. Dziarzhytski, N. Guerassimova, R. Treusch, L. S. Harbo, O. Heber, B. Jordon-Thaden, T. Arion, M. Förstel, M. Stier, U. Hergenhahn and A. Wolf, *Phys. Rev. A* **87** (2013) 013402.
- [72] C. Domesle, S. Dziarzhytski, N. Guerassimova, L. S. Harbo, O. Heber, L. Lammich, B. Jordon-Thaden, R. Treusch, A. Wolf and H. B. Pedersen, *Phys. Rev. A* **88** (2013) 043405.
- [73] L. S. Harbo, S. Dziarzhytski, C. Domesle, G. Brenner, A. Wolf and H. B. Pedersen, *Phys. Rev. A* **89** (2014) 052520.
- [74] P. Lablanquie, L. Andric, J. Paladoux, U. Becker, M. Braune, J. Vieffhaus, J. H. D. Eland and F. Penent, *J. Electron Spectrosc. Relat. Phenom.* **156-158** (2007).
- [75] H. W. Haak, G. A. Sawatzky and T. D. Thomas, *Phys. Rev. Lett.* **41** (1978) 1825.
- [76] P. Lablanquie, J.H.D. Eland, I. Nenner, P. Morin, J. Delwiche, M.J. Hubin-Franskin, *Phys. Rev. Lett.* **58** (1987) 992.
- [77] B. Kämmerling and V. Schmidt, *Phys. Rev. Lett.* **67** (1991) 1848.
- [78] J. Vieffhaus, G. Snell, R. Hentges, M. Wiedenhöft, F. Heiser, O. Geßner and U. Becker, *Phys. Rev. Lett.* **80** (1998) 1618.
- [79] P. Lablanquie, F. Penent, R. I. Hall, H. Kjeldsen, J.H.D. Eland, A. Muehleisen, P. Pelicon, Z. Šmit, M. Žitnik and F. Koike, *Phys. Rev. Lett.* **84** (2000) 47.
- [80] P. Lablanquie, S. Sheinerman, F. Penent, R.I. Hall, M. Ahmad, Y. Hikosaka and K. Ito, *Phys. Rev. Lett.* **87** (2001) 053001.
- [81] S. Rioual, B. Rouvellou, A. Huetz and L. Avaldi, *Phys. Rev. Lett.* **91** (2003) 173001.
- [82] N. Scherer, H. Lorch, T. Kerkau and V. Schmidt, *J. Phys. B: At. Mol. Opt. Phys.* **37** (2004) L121.
- [83] J. Vieffhaus, S. Cvejanovic, B. Langer, T. Lischke, G. Prümper, D. Rolles, A.V. Golovin, A.N. Grum-Grzhimailo, N. M. Kabachnik, U. Becker, *Phys. Rev. Lett.* **92** (2004) 083001.
- [84] P. Bolognesi, M. Coreno, G. Alberti, R. Richter, R. Sankari and L. Avaldi, *J. Electron Spectrosc. Rel. Phenom.* **141** (2004) 105.
- [85] J. S. Briggs and V. Schmidt, *J. Phys. B: At. Mol. Opt. Phys.* **33** (2000) R1.
- [86] S. Sheinerman, P. Lablanquie, F. Penent, J. Paladoux, J.H.D. Eland, T. Aoto, Y. Hikosaka, K. Ito, *J. Phys. B: At. Mol. Opt. Phys.* **39** (2006) 1017.
- [87] J. H. D. Eland, *Chem. Phys.* **294** (2003) 171.
- [88] Y. Hikosaka, P. Lablanquie, F. Penent, E. Shigemasa, J. H. D. Eland and K. Ito, *J. Electron Spectrosc. Rel. Phenom.* **181** (2010) 121.
- [89] R. I. Hall, A. McConkey, L. Avaldi, M. A. MacDonald and G. C. King, *J. Phys. B: At. Mol. Opt. Phys.* **25** (1992) 411.
- [90] R. I. Hall, G. Dawber, A. McConkey, M. A. MacDonald and G. C. King, *Phys. Rev. Lett.*, **68** (1992) 2751.
- [91] B. Krässig and V. Schmidt, *J. Phys. B: At. Mol. Opt. Phys.* **25** (1992) L327.
- [92] R. I. Hall, L. Avaldi, G. Dawber, A. G. McConkey, M. A. MacDonald and G. C. King, *Chem. Phys.* **187** (1994) 125.
- [93] G. C. King, L. Avaldi, G. Dawber, G. Stefani, M. Zitnik, M. A. MacDonald and R. I. Hall, *J. Electron. Spectrosc. Relat. Phenom.*, **76** (1995) 253.

- [94] A. J. Yench, G. C. King, M. C. A. Lopes, J. D. Bozek and N. Berrah, *Chem. Phys. Lett.*, **315** (1999) 37.
- [95] L. Avaldi, G. Dawber, G. C. King, G. Stefani and M. Zitnik, *Phys. Rev. A*, **52** (1995) R3409.
- [96] L. Avaldi, G. Dawber, N. Gulley, H. Rojas, G. C. King, R. Hall, M. Stuhec and M. Zitnik, *J. Phys. B: At. Mol. Opt. Phys.*, **30** (1997) 5197.
- [97] G. Dawber, A. G. McConkey, L. Avaldi, M. A. MacDonald, G. C. King and R. I. Hall, *J. Phys. B: At. Mol. Opt. Phys.*, **27** (1994) 2191.
- [98] A. G. McConkey, G. Dawber, L. Avaldi, M. A. MacDonald, G. C. King and R. I. Hall, *J. Phys. B: At. Mol. Opt. Phys.*, **27** (1994) 271.
- [99] M. Hochlaf, R. I. Hall, F. Penent, H. Kjeldsen, P. Lablanquie, M. Lavollée, J. H. D. Eland, *Chem. Phys.*, **207** (1996) 159.
- [100] M. Hochlaf, R. I. Hall, F. Penent, J. H. D. Eland, P. Lablanquie, *Chem. Phys.*, **234** (1998) 249.
- [101] F. R. Bennett, A. D. J. Critchley, G. C. King, R. J. LeRoy and I. R. McNab, *Mol. Phys.* **97** (1999) 35.
- [102] P. Bolognesi, S. J. Cavanagh, L. Avaldi, R. Camilloni, M. Zitnik, M. Stuhec and G. C. King, *J. Phys. B: At. Mol. Opt. Phys.*, **33** (2000) 4723.
- [103] P. Bolognesi, L. Avaldi, M. C. A. Lopes, G. Dawber, G. C. King, M. A. MacDonald, C. Villani and F. Tarantelli, *Phys. Rev. A*, **64** (2001) 012701.
- [104] O. Furuhashi, T. Kinugawa, N. Nakamura, S. Masuda, C. Yamada and S. Ohtani, *J. Chin. Chem. Soc.* **48** (2001) 531.
- [105] E. Jensen, R. A. Bartynski, S. L. Hubert, E. D. Johnson and R. Garrett, *Phys. Rev. Lett.*, **62** (1989) 71.
- [106] E. Jensen, R. A. Bartynski, M. Weinert, S. L. Hubert, E. D. Johnson and R. Garrett, *Phys. Rev. B*, **41** (1990) 12468.
- [107] E. Jensen, R. A. Bartynski, S. L. Hubert and E. D. Johnson, *Rev. Sci. Instrum.*, **63** (1992) 3013.
- [108] R. A. Bartynski, E. Jensen and S. L. Hubert, *Phys. Scr.*, **T41** (1992) 168.
- [109] S. D. Price and J. H. D. Eland, *J. Phys. B: At. Mol. Opt. Phys.*, **22** (1989) L153.
- [110] S. D. Price and J. H. D. Eland, *J. Phys. B: At. Mol. Opt. Phys.*, **23** (1990) 2269.
- [111] S. D. Price and J. H. D. Eland, *J. Electron Spectrosc. Relat. Phenom.*, **52** (1990) 649.
- [112] S. D. Price and J. H. D. Eland, *J. Phys. B: At. Mol. Opt. Phys.*, **24** (1991) 4379.
- [113] S. D. Price and J. H. D. Eland, *Meas. Sci. Technol.*, **3** (1992) 306.
- [114] K. Okuyama, J. H. D. Eland and K. Kimura, *Phys. Rev. A*, **41** (1990) 4930.
- [115] P. Calicchia, S. Langomarsino, F. Scarinci, C. Martinelli and V. Formoso, *Rev. Sci. Instrum.*, **70** (1999) 3529.
- [116] J. H. D. Eland, O. Vieuxmaire, T. Kinugawa, P. Lablanquie, R. I. Hall and F. Penent, *Phys. Rev. Lett.*, **90** (2003) 053003.
- [117] Y. Hikosaka and J. H. D. Eland, *Chem. Phys.* **299** (2004) 147.
- [118] F. Penent, P. Lablanquie, R. I. Hall, J. Palaudoux, K. Ito, Y. Hikosaka, T. Aoto and J. H. D. Eland, *J. Electron Spectrosc. Relat. Phenom.*, **144** (2005) 7.
- [119] J. H. D. Eland, *J. Electron Spectrosc. Relat. Phenom.*, **144** (2005) 1145.
- [120] R. Feifel and J. H. D. Eland, *Phys. Rev. A*, **71** (2005) 034501.
- [121] R. Feifel, J. H. D. Eland, L. Storchi and F. Tarantelli, *J. Chem. Phys.*, **122** (2005) 144309.
- [122] J. H. D. Eland, *Chem. Phys.*, **323** (2006) 391.
- [123] Y. Hikosaka, T. Aoto, P. Lablanquie, F. Penent, E. Shigemasa and K. Ito, *J. Phys. B: At. Mol. Opt. Phys.*, **39** (2006) 3457.
- [124] J. H. D. Eland, P. Linusson, L. Hedin, E. Andersson, J.-E. Rubensson and R. Feifel, *Phys. Rev. A*, **78** (2008) 063423.
- [125] G. Beamson, H. Q. Porter and D. W. Turner, *J. Phys. E: Sci. Instrum.*, **13** (1980) 64.
- [126] P. Kruit and F. H. Read, *J. Phys. E: Sci. Instrum.* **16** (1983) 313.

- [127] T. Tsuboi, E. Y. Xu, Y. K. Bae and K. T. Gillen, *Rev. Sci. Instrum.*, **59** (1988) 1357.
- [128] O. Cheshnovsky, S. H. Yang, C. L. Pettiette, M. J. Craycraft and R. E. Smalley, *Rev. Sci. Instrum.*, **58** (1987) 2131.
- [129] L. -S. Wang, H. -S. Cheng and J. Fan, *J. Chem. Phys.*, **102** (1995) 9480.
- [130] C. -Y. Cha, G. Ganteför and W. Eberhardt, *Rev. Sci. Instrum.*, **63** (1992) 5661.
- [131] L. -S. Wang, C. -F. Ding, X. -B. Wang and S. E. Barlow, *Rev. Sci. Instrum.*, **70** (1999) 1957.
- [132] Y. Yamakita, H. Tanaka, R. Maruyama, H. Yamakado, F. Misaizu and K. Ohno, *Rev. Sci. Instrum.*, **71** (2000) 3042.
- [133] H. Handschuh, G. Ganteför and W. Eberhardt, *Rev. Sci. Instrum.*, **66** (1995) 3838.
- [134] J. H. D. Eland and R. Feifel, *Chem. Phys.*, **327** (2006) 85.
- [135] R. Feifel, J. H. D. Eland, L. Storchi and F. Tarantelli, *J. Chem. Phys.*, **125** (2006) 194318.
- [136] A. Matsuda, M. Fushitani, C.-M. Tseng, Y. Hikosaka, J. H. D. Eland and A. Hishikawa, *Rev. Sci. Instrum.*, **82** (2011) 103105.
- [137] J. H. D. Eland, P. Linusson, M. Mucke and R. Feifel, *Chem. Phys. Lett.*, **548** (2012) 90.
- [138] W. S. M. Werner, F. Salvat-Pujol, W. Smekal, R. Khalid, F. Aumayr, F. Störi, A. Ruocco and G. Stefani, *Appl. Phys. Lett.* **99** (2011) 184102.
- [139] M. Hattass, T. Jalowy, A. Czasch, Th. Weber, T. Jahnke, S. Schössler, L. Ph. Schmidt, O. Jagutzki, R. Dörner and H. Schmidt-Böcking, *Rev. Sci. Instrum.* **75** (2004) 2373.
- [140] M. Munoz-Navia, C. Winkler, R. Patel, M. Birke, F. O. Schumann and J. Kirschner, *J. Phys.: Condens. Matter* **21** (2009) 355003.
- [141] F. O. Schumann, C. Winkler and J. Kirschner, *Phys. Status Solidi B*, **246** (2009) 1483.
- [142] G. van Riessen, Z. Wei, R. S. Dhaka, C. Winkler, F. O. Schumann and J. Kirschner, *J. Phys.: Condens. Matter* **22** (2010) 092201.
- [143] Z. Wei, F. O. Schumann, R. S. Dhaka and J. Kirschner, *Phys. Rev. B* **85** (2012) 195120.
- [144] M. Huth, C.-T. Chiang, A. Trützschler, F. O. Schumann, J. Kirschner and W. Widdra, *Appl. Phys. Lett.* **104** (2014) 061602.
- [145] F. O. Schumann, L. Behnke, C. H. Li, J. Kirschner, Y. Pavlyuk and J. Berakdar, *Phys. Rev. B* **86** (2012) 035131.
- [146] R. Walauer, S. Voss, L. Foucar, T. Bauer, D. Schneider, J. Titze, B. Ulrich, K. Kreidi, N. Neumann, T. Havermeier, M. Schöffler, T. Kahnke, A. Czasch, L. Schmidt, A. Kanigel, J. C. Campuzano, H. Jeschke, R. Valenti, A. Müller, G. Berner, M. Sing, R. Claessen, H. Schmidt-Böcking and R. Dörner, *Rev. Sci. Instrum.* **83** (2012) 103905.
- [147] L. S. Cederbaum, J. Zobeley, and F. Tarantelli, *Phys. Rev. Lett.* **79** (1997) 4778.
- [148] S. Marburger, O. Kugeler, U. Hergenhahn and T. Möller, *Phys. Rev. Lett.* **90** (2003) 203401.
- [149] U. Hergenhahn, *J. Electron Spectrosc. Relat. Phenom.* **184** (2011) 78.
- [150] T. Jahnke, A. Czasch, M. S. Schöffler, S. Schössler, A. Knapp, M. Kász, J. Titze, C. Wimmer, K. Kreidi, R. E. Grisenti, A. Staudte, O. Jagutzki, U. Hergenhahn, H. Schmidt-Böcking and R. Dörner, *Phys. Rev. Lett.* **93** (2004) 163401.
- [151] T. Jahnke, A. Czasch, M. S. Schöffler, S. Schössler, M. Kász, J. Titze, K. Kreidi, R. E. Grisenti, A. Staudte, O. Jagutzki, L. Ph. H. Schmidt, S. K. Semenov, N. A. Cherepkov, H. Schmidt-Böcking and R. Dörner, *J. Phys. B: At. Mol. Opt. Phys.* **40** (2007) 2597.
- [152] K. Kreidi, T. Jahnke, Th. Weber, T. Havermeier, R. E. Grisenti, X. Liu, Y. Morisita, S. Schössler, L. Ph. H. Schmidt, M. Schöffler, M. Odenweller, N.

- Neumann, L. Foucar, J. Titze, B. Ulrich, F. Sturm, C. Stuck, R. Wallauer, S. Voss, I. Lauter, H. K. Kim, M. Rudloff, H. Fukuzawa, G. Prümper, N. Saito, K. Ueda, A. Czasch, O. Jagutzki, H. Schmidt-Böcking, S. K. Semenov, N. A. Cherepkov and R. Dörner, *J. Phys.: Conf. Series* **212** (2010) 012007.
- [153] S. Barth, S. Marburger, O. Kugeler, V. Ulrich, S. Joshi, A.M. Bradshaw, U. Hergenhahn, *Chem. Phys.* **329** (2006) 246.
- [154] M. Förstel, T. Arion and U. Hergenhahn, *J. Electron Spectrosc. Relat. Phenom.* **191** (2013) 16.
- [155] Y. Morishita, N. Saito, I. H. Suzuki, H. Fukuzawa, X.-J. Liu, K. Sakai, G. Prümper, K. Ueda, H. Iwayama, K. Nagaya, M. Yao, K. Kreidi, M. Schöffler, T. Jahnke, S. Schössler, R. Dörner, T. Weber, J. Harries and Y. Tamenori, *J. Phys. B: At. Mol. Opt. Phys.* **41** (2008) 025101.
- [156] T. Arion, M. Mucke, M. Förstel, A. M. Bradshaw and U. Hergenhahn, *J. Chem. Phys.* **134** (2011) 074306.
- [157] M. Mucke, M. Braune, S. Barth, M. Förstel, T. Lischke, V. Ulrich, T. Arion, U. Becker, A. Bradshaw and U. Hergenhahn, *Nat. Phys.* **6** (2010) 139.
- [158] T. Jahnke, H. Sann, T. Havermeier, K. Kreidi, C. Stuck, M. Meckel, M. Schöffler, N. Neumann, R. Wallauer, S. Voss, A. Czasch, O. Jagutzki, A. Malakzadeh, F. Afaneh, Th. Weber, H. Schmidt-Böcking and R. Dörner, *Nat. Phys.* **6** (2010) 139.
- [159] U. Hergenhahn, *Int. J. Rad. Biology* **88** (2012) 871.
- [160] J. Zobeley, R. Santra and L. S. Cederbaum, *J. Chem. Phys.* **115** (2001) 5076.
- [161] M. Förstel, M. Mucke, T. Arion, A. M. Bradshaw and U. Hergenhahn, *Phys. Rev. Lett.* **106** (2011) 033402.
- [162] K. Sakai, S. Stoychev, T. Ouchi, I. Higuchi, M. Schöffler, T. Mazza, H. Fukuzawa, K. Nagaya, M. Yao, Y. Tamenori, A. I. Kuleff, N. Saito and K. Ueda, *Phys. Rev. Lett.* **106** (2011) 033401.
- [163] M. Mucke, M. Förstel, T. Lischke, T. Arion, A. M. Bradshaw and U. Hergenhahn, *Rev. Sci. Instrum.* **83** (2012) 063106.
- [164] L. J. Frasinski, K. Codling and P. A. Hatherly, *Science*, **246** (1989) 1029.
- [165] V. Zhaunerchyk, L. J. Frasinski, J. H. D. Eland and R. Feifel, *Phys. Rev. A* **89** (2014) 053418.
- [166] L. J. Frasinski, V. Zhaunerchyk, M. Mucke, R. J. Squibb, M. Siano, J. H. D. Eland, P. Linusson, P. v.d. Meulen, P. Salén, R. D. Thomas, M. Larsson, L. Foucar, J. Ullrich, K. Motomura, S. Mondal, K. Ueda, T. Osipov, L. Fang, B. F. Murphy, N. Berrah, C. Bostedt, J. D. Bozek, S. Schorb, M. Messerschmidt, J. M. Glowonia, J. P. Cryan, R. N. Coffee, O. Takahashi, S. Wada, M. N. Piancastelli, R. Richter, K. C. Prince and R. Feifel, *Phys. Rev. Lett.* **111** (2013) 073002.
- [167] V. Zhaunerchyk, M. Mucke, P. Salén, P. v.d. Meulen, M. Kaminska, R. J. Squibb, L. J. Frasinski, M. Siano, J. H. D. Eland, P. Linusson, R. D. Thomas, M. Larsson, L. Foucar, J. Ullrich, K. Motomura, S. Mondal, K. Ueda, T. Osipov, L. Fang, B. F. Murphy, N. Berrah, C. Bostedt, J. D. Bozek, S. Schorb, M. Messerschmidt, J. M. Glowonia, J. P. Cryan, R. N. Coffee, O. Takahashi, S. Wada, M. N. Piancastelli, R. Richter, K. C. Prince and R. Feifel, *J. Phys. B: At. Mol. Opt. Phys.* **46** (2013) 164034.
- [168] A. O. G. Wallis, L. Lodi, and A. Emmanouilidou, *Phys. Rev. A* **89** (2014) 063417.
- [169] P. Auger, *J. Phys. Radium* **6** (1925) 205.
- [170] R. E. Weber and W. T. Peria, *J. Appl. Phys.* **38** (1967) 4355.
- [171] L. S. Cederbaum and F. Tarantelli, *J. Chem. Phys.* **98** (1993) 9691.
- [172] R. Püttner, X.-J. Liu, H. Fuzukawa, T. Tanaka, M. Hoshino, H. Tanaka, J. Harries, Y. Tamenori, V. Caravetta and K. Ueda, *Chem. Phys. Lett.* **445** (2007) 6.
- [173] G. A. Sawatzky, *Phys. Rev. Lett.* **39** (1977) 504.
- [174] W. S. M. Werner, W. Smekal, H. Störi, H. Winter, G. Stefani, A. Ruocco, F. Offi, R. Gotter, A. Morgante and F. Tommasini, *Phys. Rev. Lett.* **94** (2005) 038302.

- [175] G. Stefani, R. Gotter, A. Ruocco, F. Offi, F. Da Pieve, S. Iacobucci, A. Morgante, A. Verdini, A. Liscio, H. Yao and R. A. Bartynski, *J. Electron Spectrosc. Relat. Phenom.* **141** (2004) 149.
- [176] J. H. D. Eland, P. Linusson, L. Hedin, E. Andersson, J.-E. Rubensson and R. Feifel, *Chem. Phys. Lett.* **485** (2010) 21.
- [177] J. H. D. Eland, C. F. Rigby, E. Andersson, J. Palaudoux, L. Andric, F. Penent, P. Linusson, L. Hedin, L. Karlsson, J.-E. Rubensson, Y. Hikosaka, K. Ito, P. Lablanquie and R. Feifel, *J. Chem. Phys.* **132** (2010) 104311.
- [178] J. H. D. Eland, M. Tashiro, P. Linusson, M. Ehara, K. Ueda and R. Feifel, *Phys. Rev. Lett.* **105** (2010) 213005.
- [179] H. Iwayama, N. Sisourat, P. Lablanquie, F. Penent, J. Palaudoux, L. Andric, J. H. D. Eland, K. Bucar, M. Žitnik, Y. Velkov, Y. Hikosaka, M. Nakano and E. Shigemasa, *J. Chem. Phys.* **138** (2013) 024306.
- [180] T. Kaneyasu, Y. Hikosaka, E. Shigemasa, P. Lablanquie, F. Penent and K. Ito, *J. Phys. B: At. Mol. Opt. Phys.* **41** (2008) 135101.
- [181] S.-M. Huttula, P. Lablanquie, L. Andric, J. Palaudoux, M. Huttula, S. Sheinerman, E. Shigemasa, Y. Hikosaka, K. Ito and F. Penent, *Phys. Rev. Lett.* **110** (2013) 113002.
- [182] V. Ulrich, S. Barth, S. Joshi, T. Lischke, A. M. Bradshaw and U. Hergenhahn, *Phys. Rev. Lett.* **100** (2008) 143003.
- [183] R. Püttner, T. Arion, M. Förstel, T. Lischke, M. Mucke, V. Sekushin, G. Kaindl, A.M. Bradshaw and U. Hergenhahn, *Phys. Rev. A* **83** (2011) 043404.
- [184] V. Ulrich, S. Barth, T. Lischke, S. Joshi, T. Arion, M. Mucke, M. Förstel, A.M. Bradshaw and U. Hergenhahn, *J. Electron Spectrosc. Relat. Phenom.* **183** (2011) 70.
- [185] T. Arion, R. Püttner, C. Lupulescu, R. Ovsyannikov, M. Förstel, G. Öhrwall, A. Lindblad, K. Ueda, S. Svensson, A.M. Bradshaw, W. Eberhardt and U. Hergenhahn, *J. Electron Spectrosc. Relat. Phenom.* **185** (2012) 234.
- [186] C. Lupulescu, T. Arion, U. Hergenhahn, R. Ovsyannikov, M. Förstel, G. Gavrila and W. Eberhardt, *J. Electron Spectrosc. Relat. Phenom.* **191** (2013) 104.
- [187] T. Arion, O. Takahashi, R. Püttner, V. Ulrich, S. Barth, T. Lischke, A. M. Bradshaw, M. Förstel and U. Hergenhahn, *J. Phys. B: At. Mol. Opt. Phys.* **47** (2014) 124033.
- [188] W. L. Jolly, K. D. Bomben, and C. J. Eyermann, *Atomic Data and Nuclear Data Tables* **31** (1984) 433.
- [189] T. D. Thomas, *J. Am. Chem. Soc.* **92** (1970) 4184.
- [190] W. E. Moddeman, PhD Thesis, Oak Ridge National Laboratory, ORNL-TM-3012 (1970).
- [191] R. Dörner, V. Mergel, O. Jagutzki, L. Spielberger, J. Ulrich, R. Moshhammer and H. Schmidt-Böcking, *Phys. Rep.* **330** (2000) 95.
- [192] J. Ullrich, R. Moshhammer, R. Dörner, O. Jagutzki, V. Mergel, H. Schmidt-Böcking and L. Spielberger, *J. Phys. B: At. Mol. Opt. Phys.* **30** (1997) 2917.
- [193] J. Ullrich, R. Moshhammer, A. Dorn, R. Dörner, L. Ph. H. Schmidt and H. Schmidt-Böcking, *Rep. Prog. Phys.* **66** (2003) 1463.
- [194] R. Moshhammer, M. Unverzagt, W. Schmitt, J. Ullrich, H. Schmidt-Böcking, *Nucl. Instr. and Meth. B* **108** (1996) 425.
- [195] T. Havermeier, T. Jahnke, K. Kreidi, R. Wallauer, S. Voss, M. Schöffler, S. Schössler, L. Foucar, N. Neumann, J. Titze, H. Sann, M. Kühnel, J. Voigtsberger, J.H. Morilla, W. Schöllkopf, H. Schmidt-Böcking, R. E. Grisenti and R. Dörner, *Phys. Rev. Lett.* **104** (2010) 133401.
- [196] T. Havermeier, T. Jahnke, K. Kreidi, R. Wallauer, S. Voss, M. Schöffler, S. Schössler, L. Foucar, N. Neumann, J. Titze, H. Sann, M. Kühnel, J. Voigtsberger, A. Malakzadeh, N. Sisourat, W. Schöllkopf, H. Schmidt-Böcking, R. E. Grisenti and R. Dörner, *Phys. Rev. Lett.* **104** (2010) 153401.
- [197] T. Jahnke, Th. Weber, A. L. Landers, A. Knapp, S. Schössler, J. Nickles, S.

- Kammer, O. Jagutzki, L. Schmidt, A. Czasch, T. Osipov, E. Arenholz, A. T. Young, R. Díez Muiño, D. Rolles, F. J. García de Abajo, C. S. Fadley, M. A. Van Hove, S. K. Semenov, N. A. Cherepkov, J. Rösch, M. H. Prior, H. Schmidt-Böcking, C. L. Cocke and R. Dörner, *Phys. Rev. Lett.* **88** (2002) 073002.
- [198] T. Jahnke, Th. Weber, T. Osipov, A. L. Landers, O. Jagutzki, L. Ph. H. Schmidt, C. L. Cocke, M. H. Prior, H. Schmidt-Böcking, R. Dörner, *J. Electron Spectrosc. Relat. Phenom.* **141** (2004) 229.
- [199] T. Jahnke, L. Foucar, J. Titze, R. Wallauer, T. Osipov, E. P. Benis, A. Alnaser, O. Jagutzki, W. Arnold, S. K. Semenov, N. A. Cherepkov, L. Ph. H. Schmidt, A. Czasch, A. Staudte, M. Schöffler, C. L. Cocke, M. H. Prior, H. Schmidt-Böcking and R. Dörner, *Phys. Rev. Lett.* **93** (2004) 083002.
- [200] T. Jahnke, A. Czasch, M. Schöffler, S. Schössler, M. Kász, J. Titze, K. Kreidi, R.E. Grisenti, A. Staudte, O. Jagutzki, L. Ph. H. Schmidt, Th. Weber, H. Schmidt-Böcking, K. Ueda and R. Dörner, *Phys. Rev. Lett.* **99** (2007) 153401.
- [201] M. Kurka, A. Rudenko, L. Foucar, K. U. Kühnel, Y. H. Jiang, Th. Ergler, T. Havermeier, M. Smolarski, S. Schössler, K. Cole, M. Schöffler, R. Dörner, M. Gensch, S. Düsterer, R. Treusch, S. Fritzsche, A. N. Grum-Grzhimailo, E. V. Gryzlova, N. M. Kabachnik, C. D. Schröter, R. Moshhammer and J. Ullrich, *J. Phys. B: At. Mol. Opt. Phys.* **42** (2009) 141002.
- [202] A. Rudenko, Y. H. Jiang, M. Kurka, K. U. Kühnel, L. Foucar, O. Herrwerth, M. Lezius, M. F. Kling, C. D. Schröter, R. Moshhammer and J. Ullrich, *J. Phys. B: At. Mol. Opt. Phys.* **43** (2010) 194004.
- [203] F. Trinter, J. B. Williams, M. Weller, M. Waitz, M. Pitzer, J. Voigtsberger, C. Schober, G. Kastirke, C. Müller, C. Goihl, P. Burzynski, F. Wiegandt, T. Bauer, R. Wallauer, H. Sann, A. Kalinin, L. Ph. H. Schmidt, M. Schöffler, N. Sisourat and T. Jahnke, *Phys. Rev. Lett.* **111** (2013) 093401.
- [204] K. Schnorr, A. Senfleben, M. Kurka, A. Rudenko, L. Foucar, G. Schmid, A. Broska, T. Pfeifer, K. Meyer, D. Anielski, R. Boll, D. Rolles, M. Kübel, M. F. Kling, Y. H. Jiang, S. Mondal, T. Tachibana, K. Ueda, T. Marchenko, M. Simon, G. Brenner, R. Treusch, S. Scheit, V. Averbukh, J. Ullrich, C. D. Schröter and R. Moshhammer, *Phys. Rev. Lett.* **111** (2013) 093402.
- [205] G. Öhrwall, P. Karlsson, M. Wirde, M. Lundqvist, P. Andersson, D. Ceolin, B. Wannberg, T. Kachel, H. Dürr, W. Eberhardt and S. Svensson, *J. Electron Spectrosc. Relat. Phenom.* **183** (2011) 125.
- [206] R. Ovsyannikov, P. Karlsson, M. Lundqvist, C. Lupulescu, W. Eberhardt, A. Föhlisch, S. Svensson and N. Martensson, *J. Electron Spectrosc. Relat. Phenom.* **191** (2013) 92.
- [207] J. Berakdar, *Phys. Rev. B* **58** (1998) 9808.
- [208] N. Fominykh, O. Kidun, A. Ernst and J. Berakdar, *J. Phys. B: At. Mol. Opt. Phys.* **36** (2003) 1.
- [209] K. A. Kouzakov and J. Berakdar, *Phys. Rev. Lett.* **91** (2003) 257007.
- [210] B. Winter, R. Weber, W. Widdra, M. Dittmar, M. Faubel and I. V. Hertel, *J. Chem. Phys. A* **108** (2004) 2625.
- [211] B. Winter, *Nucl. Instr. Methods in Phys. Res. A* **601** (2009) 139.
- [212] A. Wolf, H.B. Pedersen, L. Lammich, B. Jordon-Thaden, S. Altevogt, C. Domesle, U. Hergenhahn, M. Förstel, and O. Heber, *J. Phys. B*, **43**, 194007 (2010).
- [213] S. Bari, O. Gonzalez-Magaña, G. Reitsma, J. Werner, S. Schippers, R. Hoekstra, and T. Schlathölder, *J. Chem. Phys.* **134**, 024314 (2011).