

" R E S I "

A first Stage of an Online Data Acquisition and  
Analysis System for Low- $\beta$  Experiments

S. Rehker, D. Zimmermann

IPP 2/219

IPP 4/115

Januar 1974

**MAX-PLANCK-INSTITUT FÜR PLASMAPHYSIK**

**GARCHING BEI MÜNCHEN**



IPP 2/219  
IPP 4/115

# MAX-PLANCK-INSTITUT FÜR PLASMAPHYSIK

## GARCHING BEI MÜNCHEN

"RESI"

A first Stage of an Online Data Acquisition and  
Analysis System for Low- $\beta$  Experiments

S. Rehker, D. Zimmermann

IPP 2/219

IPP 4/115

Januar 1974

*Die nachstehende Arbeit wurde im Rahmen des Vertrages zwischen dem  
Max-Planck-Institut für Plasmaphysik und der Europäischen Atomgemeinschaft über die  
Zusammenarbeit auf dem Gebiete der Plasmaphysik durchgeführt.*

IPP 2/219

IPP 4/115

S. Rehker, D. Zimmermann

"RESI" A first Stage of an Online Data Acquisition and Analysis  
System for Low- $\beta$  Experiments

Abstract:

As a first stage of a data acquisition system for low- $\beta$  experiments the system "RESI" has been written and operated by the authors. Up to now 5 measured quantities can be digitized and stored by "RESI". A number of analysis programs are included in the system with which the user can perform calculations from the experimental data between the shots. Hardware and software of this system is described in this report.

## I. Introduction

To date the major means of acquiring data from an experiment is by polaroid pictures of oscilloscope traces. In the present generation of experiments (stellarator and tokamak) the large mass of the data requires more modern methods for data acquisition and analysis. This is true to a degree that future low- $\beta$ -experiments are hardly conceivable without such data acquisition systems. For the WENDELSTEIN stellarators (W IIb, W VII), as well as for the tokamaks (PULSATOR and ASDEX), data acquisition systems have been developed in the institute whose central unit is a small computer of the type PDP 11. Using a part of the peripheral hardware available on the system designated for the stellarators the authors of this report have developed and operated a software-system called "RESI" on the experiment W 2 b. This system digitalizes 5 of the most important parameters, stores it in the computer, and writes it on disk and tape along with the initialisation block. It includes a number of analysis programs which allow calculation immediately after the shot or at some other time in the future.

For the further study and solution of problems connected with data acquisition the Institute for Plasma Physics has formed a special group, which will treat these problems for the stellarators and for the tokamaks jointly. The present system "RESI" which has only solved a small part of the task will be superseded by a new system which will be developed by this special group. However, the experience gained with the present system must be taken into account in the development of this new system.

The W II b experiment is an ohmically heated stellarator. Under certain assumptions the temporal evolution of the discharge can be adequately represented by a very limited number of parameters such as ohmic heating voltage, plasma current, magnetic field strengths, and microwave interferometer signals. When the assumptions are corroborated by other diagnostics, the parameters listed above allow many different analyses to be made.



Without a data acquisition system such as "RESI", polaroid pictures of the oscilloscope traces had to be digitized to allow analysis. A large advance in the digitalization and the possibility of the subsequent calculation was achieved by the use of the instrument called "Delta 70". As described in [3] this unit digitizes polaroid pictures and stores the data on magnetic tape. This tape could then be used on the computing facility of the IPP (IBM 360/91) and calculation could then proceed on this machine.

But on the W II b stellarator the experimental time is relatively long (20 - 30 ms), so that direct acquisition of data from W II b and other such experiments becomes possible.

This is in opposition to high- $\beta$  experiments for which the unit "Delta 70" had been developed where the experimental time is much shorter. Using direct acquisition, analyzed data is thus available for the next shot of the pulsed experiment; something which is not possible for operation using "Delta 70".

Section 2 of this report describes the experiment. The third section is devoted to the hardware of the data acquisition system for the WENDELSTEIN stellarators and in particular to that part of the hardware used by "RESI". Section 4 describes the software. It is divided into 3 sections, the first of which describes the supervising program, the second the programs devoted to data acquisition, whereas the third the analysis programs. Section five summarizes the experience with the "RESI" software system.

## II. Description of the Experiment W II b

As the experimental apparatus and the results of the stellarator W II b are described in some detail elsewhere [1, 2], only a short description of the experiment will be given here.

The experimental device consists of a toroidal vessel on which the helical windings are mounted. Together with the main field the helical windings produce the vacuum

magnetic field. Following suitable preionisation a transformer induces a voltage  $U_R(t)$  inside the vessel. This loop-voltage drives the plasma current  $I_p(t)$ . A time varying  $B_z$ -field determines the position of plasma ring. The density of the plasma is measured by 5-channel microwave interferometer. Further diagnostics are described in [1, 2].

In particular the "RESI" system treats the following 5 experimental parameters

- 1) loop voltage  $U_R(t)$
- 2) time derivative of plasma current  $\frac{dI_p}{dt}$
- 3) plasma current  $I_p(t)$
- 4)  $B_z$ -field  $B_z(t)$
- 5) one channel of the microwave interferometer  $\varphi(t)$

This data is obtained sequentially over a time of 40 ms. During this time 200 points for each channel are obtained.

### 3. Hardware

Fig. 1 is a schematic of the WENDELSTEIN data acquisition system showing the central computing unit with its peripherals. The present data acquisition system "RESI" is the first stage of the system and uses only a fraction of the existing peripheral unit (Fig.2)

The following description is limited to those parts of the system used by "RESI".

#### 3.1 Computer and computer-oriented peripherals

The central unit of the system is a computer of the type PDP 11/20 from Digital Equipment Corporation. It has a core storage capacity of 16 k words and a circle time of 950 ns.



The disk (256 k) allows a disk operating system (DOS) to be used which simplifies the development and execution of programs. As the disk capacity is sufficient only for generation of the "RESI" system, for storage of the system programs, or for storage of the experimental data, system- and user programs must be stored on DEC-tapes. The other magnetic tape unit has 9 tracks and is compatible with the tape units of the computing facility of the IPP (IBM). The experimental data temporarily stored on disk are permanently stored on the 9 track tape. More extensive data analysis can then be performed on the central computing facility. Alternatively data can be recalled from the magnetic tape to the PDP 11 for smaller computations. Output from "RESI" and display of results occurs on a Tektronix computer terminal with display unit. A hard copy unit for permanent registration is available.

### 3.2 Experiment-oriented peripherals

At the present stage the data acquisition system "RESI" deals with five signals from the experiment W II b which are relatively slow so that a sample time of 200 microseconds suffices. The five signals are handled by a multiplexer with "sample and hold" and a following analog-to-digital converter (ADC). The acquisition is controlled by a trigger generator, which is started by a trigger signal from the experiment. Macroscopic functions of the system are determined by a key-board. The multiplexer used is a 32-channel multimode multiplexer. In the "RESI"-system it is operated in sequential mode, which means that after the start pulse (fig. 2) the signal is sampled by a "sample and hold" circuit and the channel address is then automatically incremented. The program ensures that the multiplexer starts at channel 0. The channels are scanned cyclically up to the final channel, which is indicated by a switch on the front panel. The signal samples are then digitized by the ADC to 11 bits plus a sign. The conversion time of the ADC is approximately 9  $\mu$ s.

Because the multiplexing unit contains no separate storage it is necessary to store the digitized data in the core of the computer. When the conversion time of the ADC and

the switching time of the multiplexer are added to the necessary program time for storage a minimal cycle time of 40 microseconds results.

The key-board with which the user controls the "RESI" system is composed of 16 keys. The function of each key is determined by the software. Because of the long cable necessary between an experimental area and the computer location (ca. 40 m) it was necessary to provide driver stages for the key-board and an own power supply for the internal key-board logic.

#### 4. Description of the Software System "RESI"

##### 4.1 Supervising Program

The system "RESI" consists of a supervising program resident in core and of a number of overlay programs. The overlay programs are called by this supervisor from disk and are loaded to core. The supervisor program performs no calculation. Instead it controls by way of the keyboard the operation of the overlay programs. Information is transferred between the overlay programs and the supervising program by way of "COMMON" regions resident in core.

In particular "RESI" consists of the following:

- RESI Resident supervisor
- ERF Overlay for data acquisition (Subroutine ADCERF)  
as well as for writing data onto disk by means of the  
subroutine SAVE.
- INIT Overlay for initialization of data characterizing the  
experimental configuration.
- COPY Overlay for copying data from disk to tape.
- SCR Overlay for erasing data from disk subsequent to overlay COPY.
- WR Overlay for display of questions to the user.



In addition the system contains the following analysis programs which are also called in the form of overlays by the supervising program.

- |     |  |
|-----|--|
| A1  | Reproduction of raw data   |
| A2  | Calculation of resistive voltage, power input, plasma resistivity, and conductivity, temperature and display of these quantities |
| A3  | Calculation of position of plasma column   |
| A4A | Interactive program for indicating the proper branch of the "arcsin-function" in the determination of the density                |
| A4B | Calculation of density, plasma energy and energy confinement time and the display of these quantities                            |
| A5  | Calculation and display of further physical quantities   |
| A6  | X-Y plots (A1-A5 produce display against the time axis).   |

The process of data acquisition is illustrated in Fig.3.

An example:

After "RESI" is started by the PDP 11-monitor, "RESI" asks if data acquisition or data analysis is desired. If the answer is "YES" INIT initializes the experimental constants. Then "RESI" calls overlay ERF which waits for the triggering signal from the experiment (Fig.4). After the trigger comes data is accepted, converted, and written to disk. "RESI" then asks if analysis is desired (Fig.5). If key "0" is then pressed "RESI" calls overlay ERF and waits for the next shot. If key "1" is pressed "RESI" asks which analysis program is desired (Fig.6). The desired program is then called to core and the experimental data is read from disk to core. After all calculations are completed "RESI" returns to overlay ERF and waits for the next shot.

The user has two other possibilities for utilizing dead-time in the experiment. He can copy the data from disk onto tape or he can perform an analysis of previous shots which are already stored on the disk or exist on the magnetic tape in use.

## 4.2 Description of Data Acquisition Programs

### Overlay ERF:

ERF first produces a message on the display unit that the system is ready for the next shot (Fig.4). This message contains the following information: the next shotnumber, how many shots are already written to disk, and the maximum number of shots which can be accommodated on the disk. Then the subroutine ADCERF is called, which remains in a wait-loop until the trigger from the experiment is received. Following the trigger data is accepted, digitized, and the sequential string is ordered according to the channel number. ERF then calls the subroutine SAVE which defines a file on the disk. This subroutine writes the initialization-block and the data onto the disk.

### Overlay INIT:

This program reads in the following parameters: An arbitrary title, the shotnumber, the number of channels, the length of the vectors, the length of time of the measurement, and the maximum number of shots which can be stored on the disk. In addition, the following physical parameters are presently read in by this program: Magnetic field, the external rotational transform, the filling pressure, and the effective ionic charge. These quantities are used only in the calculations performed in the analysis programs. At the user's option all these data or only the set of physical data may be re-initialized.

### Overlays COPY and SCR:

Because of the relatively high repetition frequency on the W II b experiment and the limited disk capacity it is necessary to copy the acquired data from disk to tape after about two hours of experimental time. The overlay COPY copies from disk onto tape whereas the overlay SCR subsequently erases the disk.

### Overlay WR:

This overlay questions the user by way of the display.



### 4.3 Description of the analysis programs

The following list gives the presently available analysis programs in "RESI". Some of the programs may be extended to perform more calculations. It is also possible to add other analysis programs to the "RESI" system.

#### Program A1:

A1 first displays the initialization data. Then the raw data may be displayed according to key-board entries.

#### Program A2:

A2 calculates from the raw data the following physical quantities and displays them on the screen:

(1) 
$$U_{\Omega} = U_p - L \frac{dI_p}{dt}$$
 Resistive voltage

where L is the inductivity of the plasma current (assumed to be constant in time)

(2) 
$$P = U_{\Omega} \cdot I_p$$
 Ohmic power

(3) 
$$R = \frac{U_{\Omega}}{I_p}$$
 Plasma resistance

(4) 
$$T_L = \left( \frac{0.5 \cdot Z_{eff}}{R} \right)^{3/2}$$
 Conductivity temperature  
(see Fig.8).

#### Program A3:

A3 calculates the position of the plasma column from the measured value of the  $B_z$ -field and of the plasma current as a function of time.

Program A4A:

The following relationship describes the dependence of phase-shift  $\varphi$  of the microwave diagnostics on density:

$$n(t) = \alpha \cdot \arcsin(\varphi(t))$$

where  $\alpha$  is a geometric constant.

Because the phase-shift frequently exceeds  $\pi/2$  -radians the relationship between density and phase-shift is not single-valued. It is then necessary to determine the proper branch for the calculation of the density. For this purpose the following interactive method is used: The measured phase-shift is displayed on the screen and the curve is then redrawn slightly shifted from the original. When the phase shift reaches an odd multiple of  $\pi/2$  the display is stopped using the key-board and the user indicates whether the density is increasing or decreasing. For control purposes the limits between the branches are plotted after the complete curve has been redrawn (Fig.9). The user may then repeat the procedure if he so desires. If the limits have been defined correctly "RESI" continues in program A4B or A6.

Program A4B:

Using the information given in A4A this program calculates

- (1)  $n(t) = \alpha \cdot \arcsin(\varphi(t))$  Plasma density  
(see Fig.10)
- (2)  $P_{ENER} = \text{const} \cdot n(t) \cdot T_L(t)$  Plasma energy
- (3)  $\tau_E = \frac{P_{ENER}}{\left(P - \frac{dP_{ENER}}{dt}\right)}$  Energy-containment time

where P is the ohmic power in the plasma (e.g.A2).

Program A5:

A5 calculates:

(1)  $T_{BOHM} = \text{const} \cdot \frac{B_0}{T_L}$   $T_{Bohm}$

where  $B_0$  is the main field,  $T_L$  the conductivity temperature.

$$(2) \quad L = L_0 + L_p = L_0 + \text{const} \cdot \frac{I_p}{B_0}$$

The total rotational transform which obtains from the external rotational transform  $L_0$  to which is added the rotational transform of the plasma current (Fig. 11). Both functions are plotted for two different assumed plasma radii.

#### Program A6:

In contradiction to all previously mentioned analysis programs this program plots calculated quantities against quantities other than time to illustrate functional dependencies.

To date we have the following combinations:

- (1)  $P_{\text{ENER}}$  plasma energy as a function of rotational transform  $L$  (Fig. 12).
- (2)  $\tau_E$  energy containment time as a function of the rotational transform  $L$ .
- (3)  $\tau_E$  energy containment time as a function of the plasma current  $I_p$ .
- (4)  $\tau_E \frac{L_p}{L}$  as a function of the conductivity temperature  $T_L$ .
- (5)  $P_{\text{ENER}}$  plasma energy as a function of  $I_p$ .

#### 5. Conclusions

In this section the most important experiences with the "RESI"-system are summarized.

Experimental data can be reliably obtained and stored by the data acquisition system.

Using available monitor programs it is simple to tabulate the numbers of accepted shots.

The data handled by the system are available at any convenient time for further calculations.

As an extension of this system to more analysis programs is easily possible, it is also possible to use these new analysis programs to perform calculations on old data.

The time saved by the experimental physicists is probably already large enough to justify the effort expended in producing the system. In addition, however, the data acquisition system allows a more exact and faster analysis of experimental data. In particular it allows an extensive analysis after each shot.



In contrast to previous methods of data handling (polaroid pictures or "Delta 70") it is now possible to perform the above analysis between two shots of the pulsed experiment so that the experience of the previous shot can be used to determine the parameters of the next shot. For example the calculation of conductivity temperature required approximately one hour by hand. The same calculation can be performed in seconds by the data acquisition system.

Generation, modification, and operation of the "RESI"-system is at present inhibited by the limited capacity of the disk. Even if a large part of the DOS-programs is stored on DEC-tapes it is possible to store only about 50 shots on the disk. Following this the data must be transcribed from disk onto tape. This requires a longer pause in the experiment which is not always possible. Under such circumstances some shots are then lost for later analysis of data. Analysis of previous shots is also made more difficult by the same problem, because the corresponding tape must be mounted and the correct shot must be found. The search through the tape can take a few minutes which then disturbs the experimental procedure. The extension of the present system with a cartridge disk of much larger capacity will allow analysis of shots taken several months ago.

Smaller modifications of the system e.g. of the analysis programs can then be performed much faster than at present (in approximately 5 minutes as compared to approximately 40 minutes now). Using this disk the comparison between experimental data and new hypotheses can be effected almost immediately.

The extension of the system is limited by the present hardware. Since the data are passed from the experiment by means of a multiplexer, an increase of the number of channels means a decrease in the time resolution. To retain the necessary resolution the system will be extended by experiment oriented peripherals. E.g. slow channels will be used to obtain the operating parameters of the magnetic configuration which at present are read in by hand (overlay INIT). In addition some fast channels with a sampling frequency of approx. 5 MHz are necessary. Development of specific hardware of even faster diagnostic (e.g. laser scattering) will also be necessary.

It has been mentioned initially that the further problems connected with data acquisition will be reserved for a special group at the IPP. This type of organization should avoid a duplication of efforts and lead to an increased concentration on the essential problems connected with data acquisition systems.

### Acknowledgement

We should like to thank Drs. H. Renner, G. Pacher, and H. Hacker from the W II b-team, Dr. R. Lathe, H. Krikava for their help writing the software system, G. Hagl for his work on the hardware and G. Daube for typing the manuscript.

### References

- 1) G. Grieger et al. IPP 2/203 May 1972
- 2) G. Grieger et al. 6th European Conference on Controlled Fusion and Plasma Physics, Moskau 1973, p. 101
- 3) J. Schneider, R. Wunderlich Datenerfassung an Delta 70. IPP 1/135; IPP R/6, Sept. 73

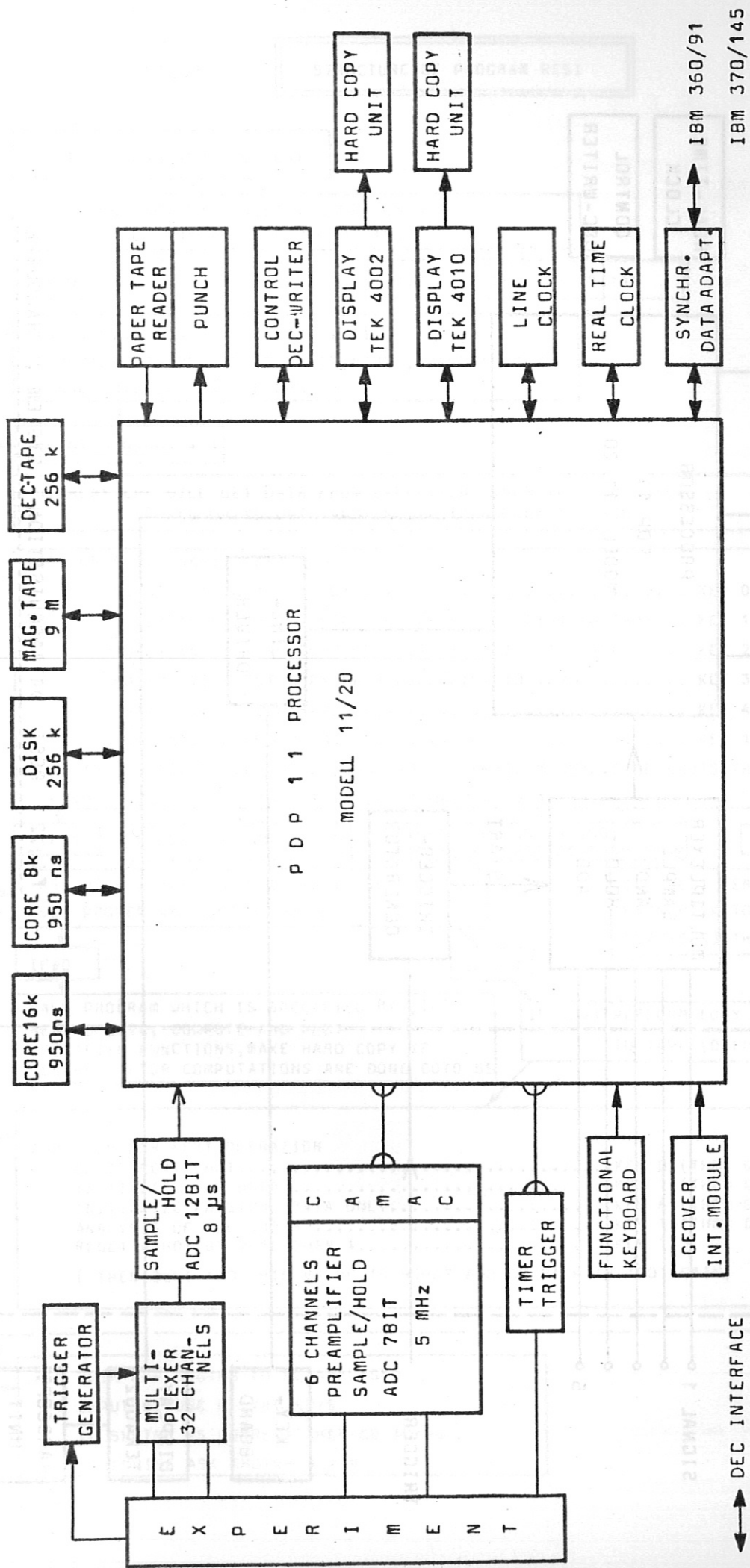

W E N D E L S T E I N D A T A A C Q U I S I T I O N S Y S T E M

F i g . 1

- ↔ DEC INTERFACE
- ⊖ CAMAC INTERFACE
- ↔ SPECIAL INTERFACE



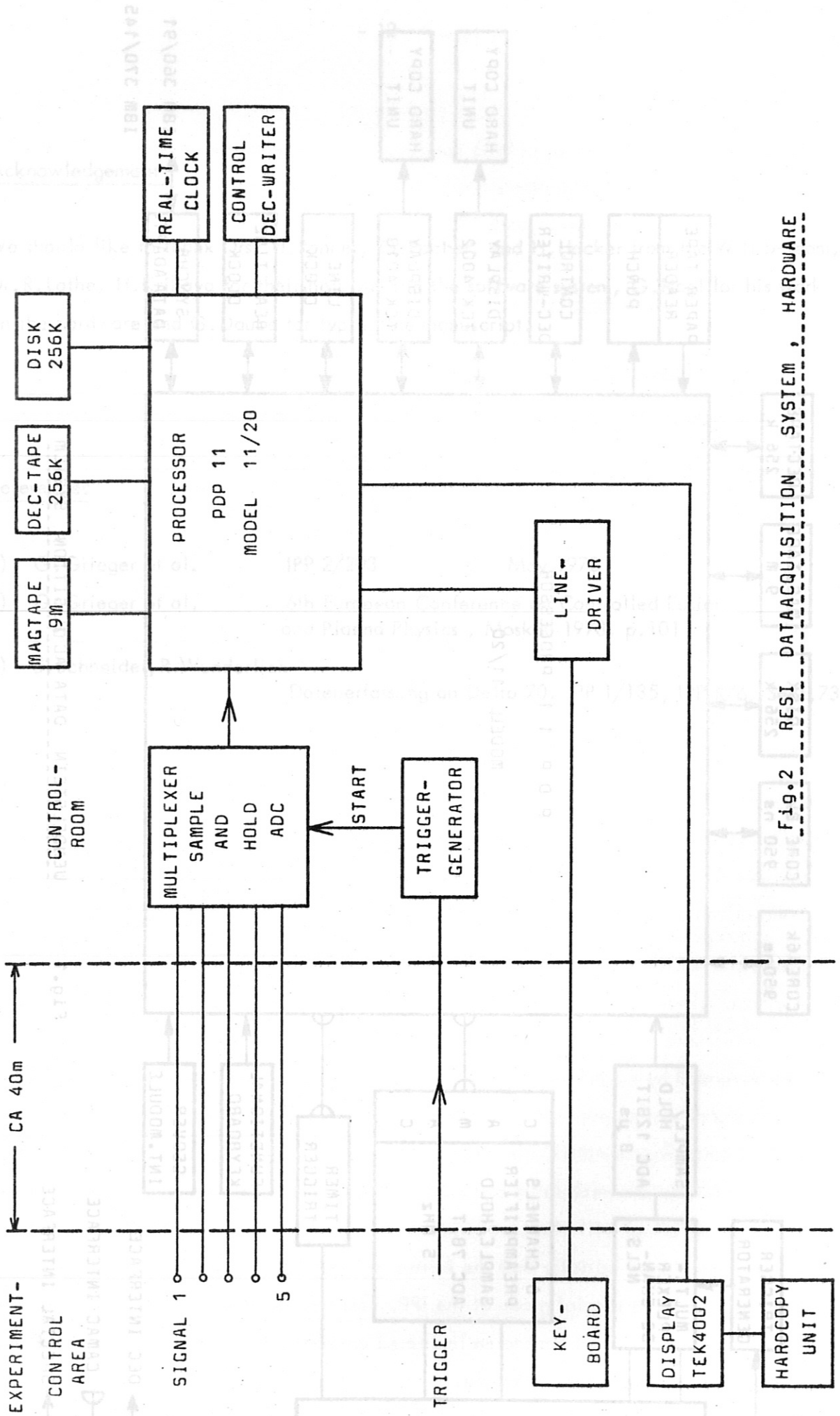
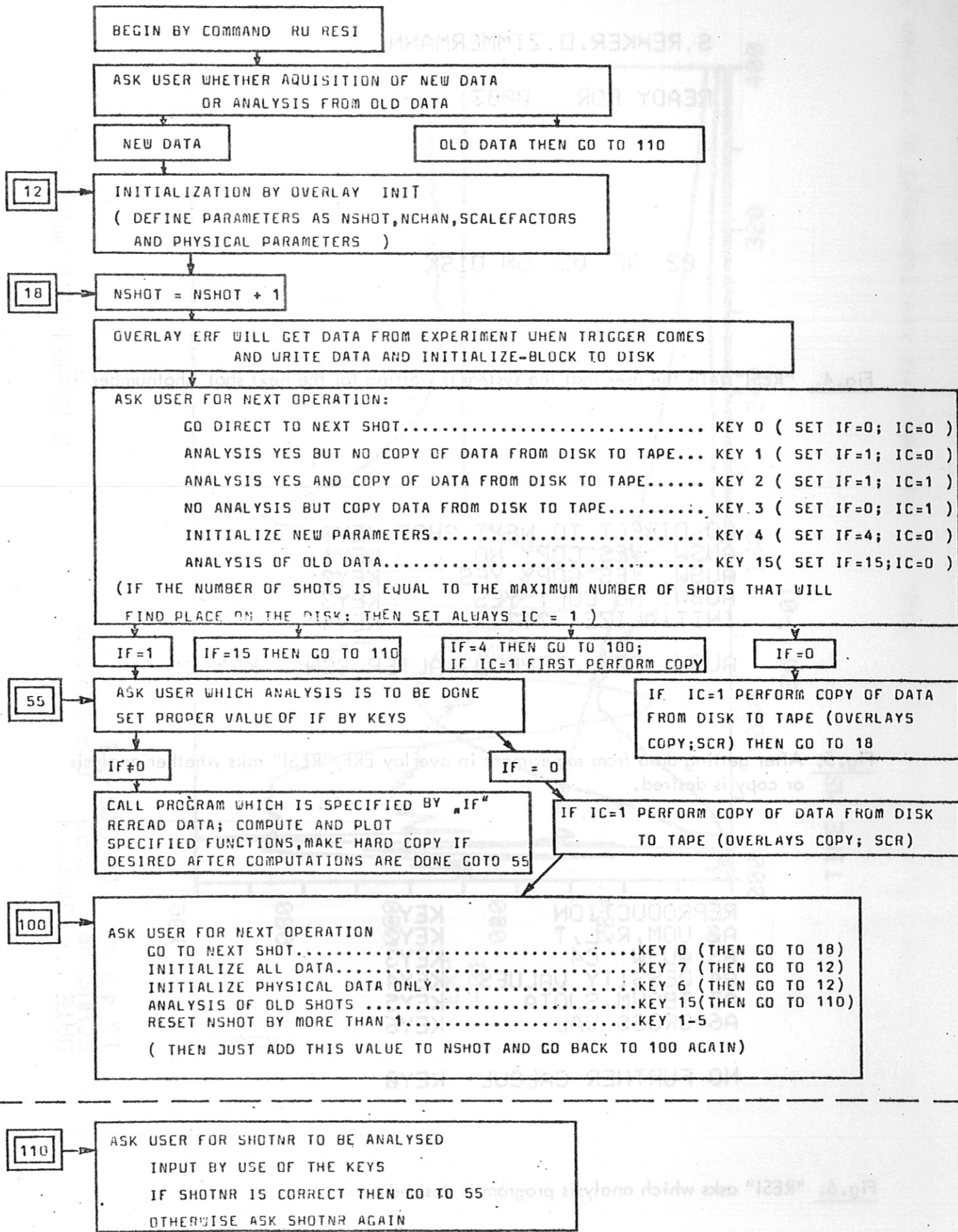

Fig.3

STRUCTURE OF PROGRAM RESI



R E S I

S. REHKER, D. ZIMMERMANN

READY FOR 0003

02 OF 05 ON DISK

Fig. 4. "RESI" tells the user that the system is waiting for the next shot (shotnumber 3).

GO DIRECT TO NEXT SHOT KEY0  
AUSW. YES COPY NO KEY1  
AUSW. YES COPY YES KEY2  
AUSW. NO COPY YES KEY3  
INITIALIZE ??? KEY4

AUSW. BZW. REPROD. ALTER SCH. KEY 15

Fig. 5. After getting data from experiment in overlay ERF, "RESI" asks whether analysis or copy is desired.

REPRODUCTION KEY1  
A2 UOM, R, L, T KEY2  
A3 AUSW. C4 KEY3  
A4 DENSITY VALUES KEY4  
A5 TBOHM, SJOTA KEY5  
A6 CROSS VAL. KEY6  
NO FURTHER CALCUL KEY0

Fig. 6. "RESI" asks which analysis program is desired.



S. REHKER, D. ZIMMERMANN

DATE 14-JAN-74  
SCHUSSNR 5202 CURVE NB00  
13:42:46 18-OCT-73

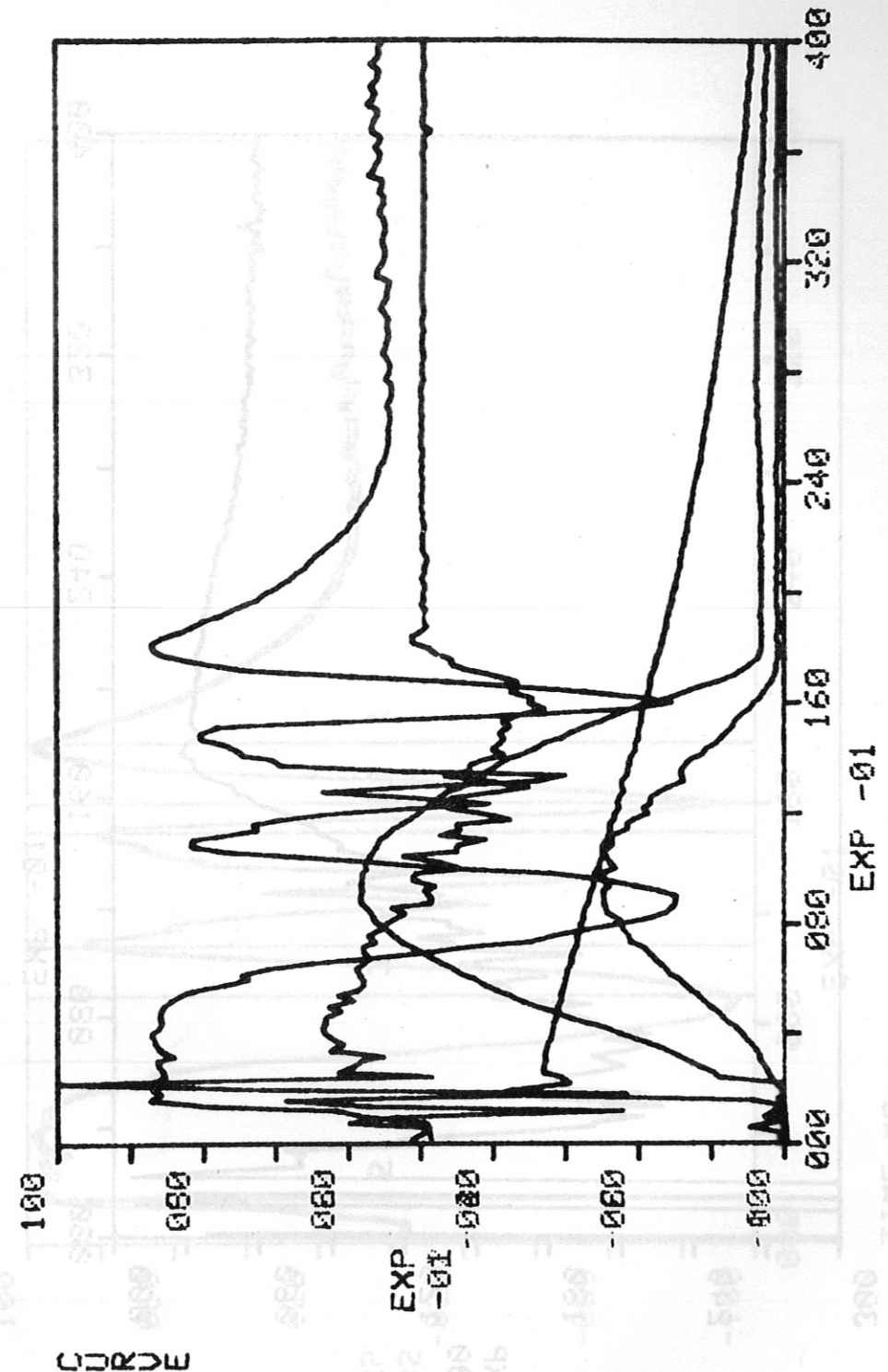

Fig. 7 : The raw data are displayed by program A1.

DATE 14-JAN-74  
SCHUSSNR 5222 CURVE NB04  
13:42:46 18-OCT-73

S. REHKER, D. ZIMMERMANN

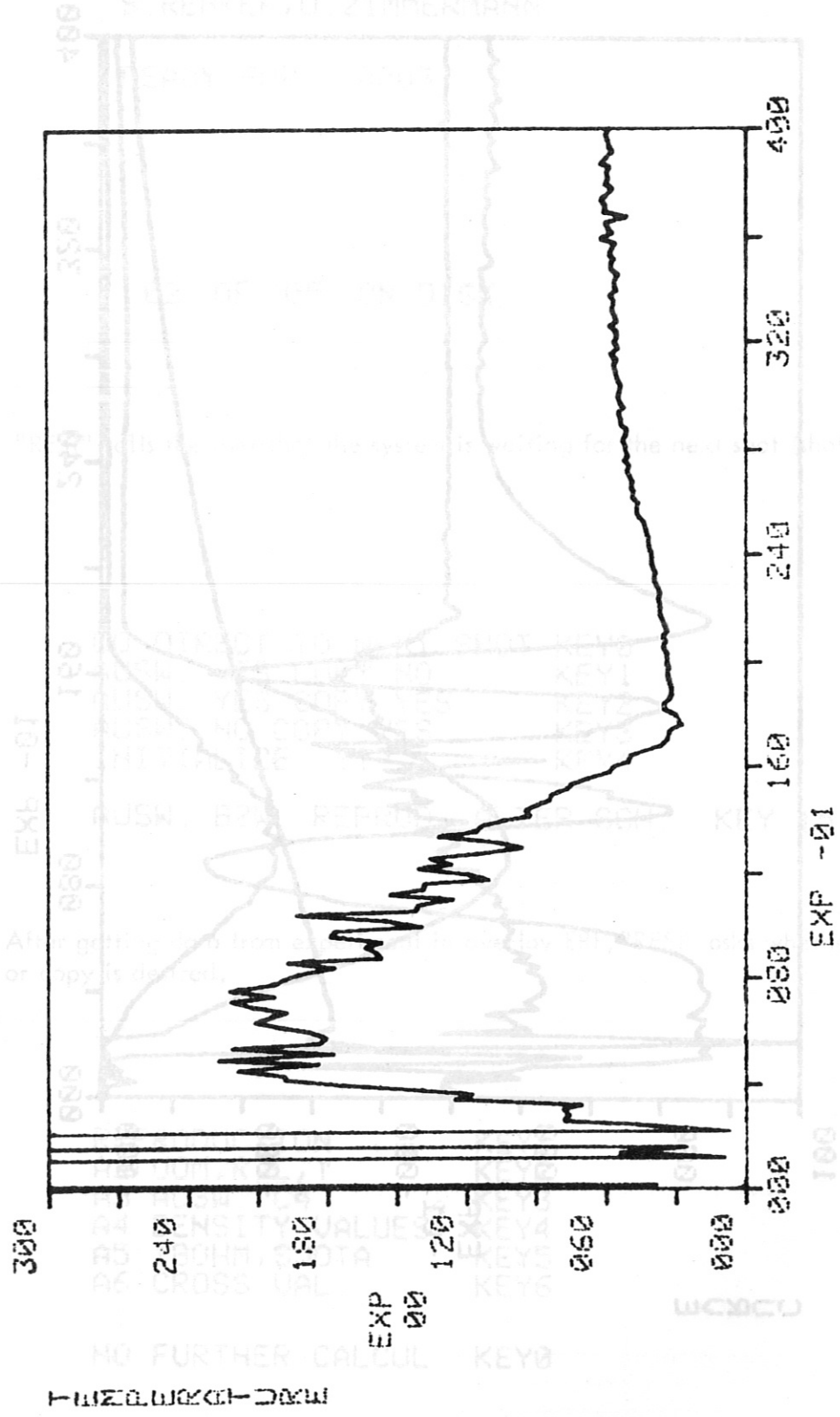
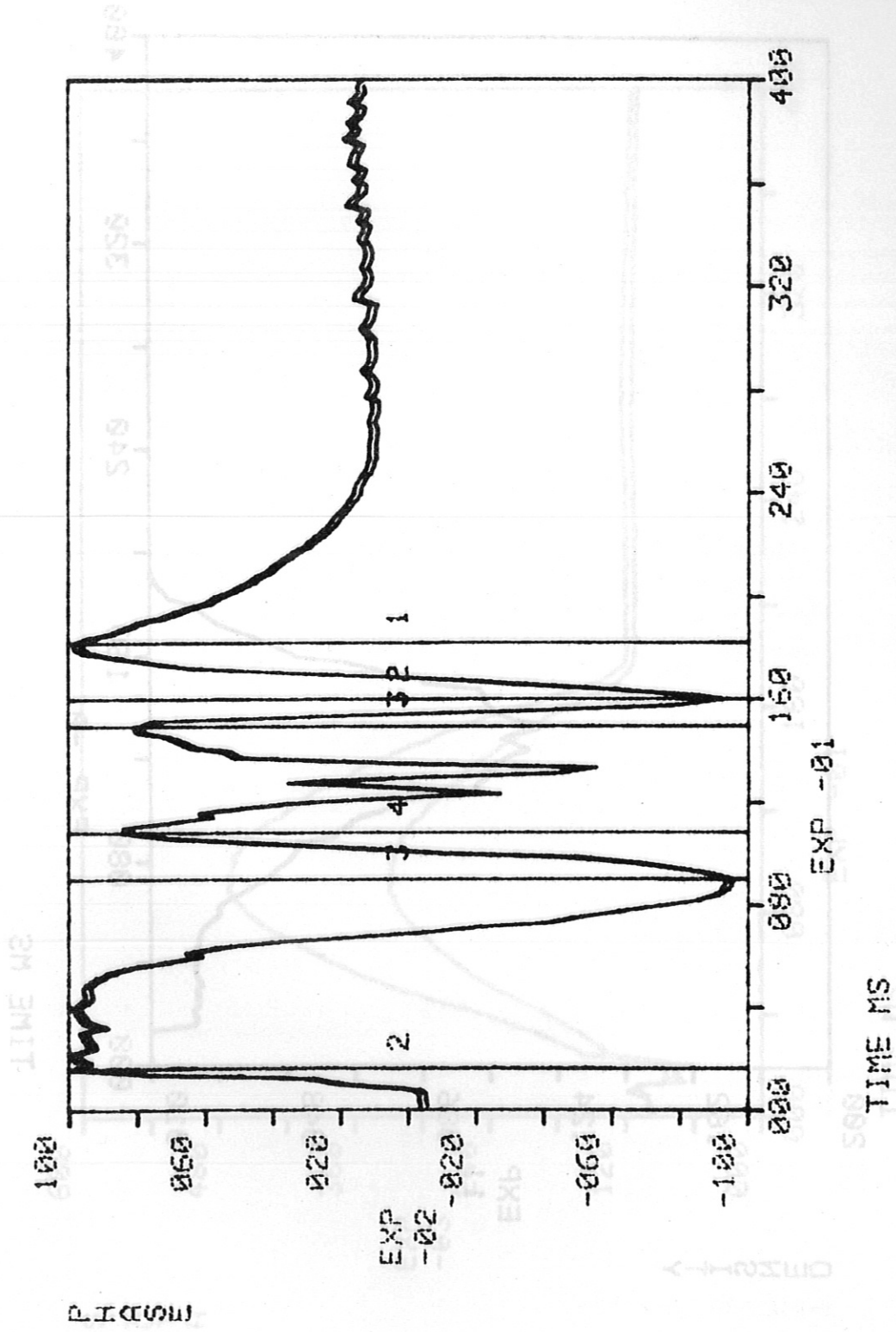

Fig. 8 : Conductivity temperature computed and displayed against time by program A2. REHKER, D. ZIMMERMANN

"RESI" asks which analysis program is desired.

DATE 14-JAN-74  
SCHUSSNR 5202  
13:42:46 18-OCT-73

S. REHKER, D. ZIMMERMANN



13:45:40 18-OCT-73  
SCHUSSNR 5202  
DATE 14-JAN-74

WIEDERHOLUNG JA ODER NEIN

Fig. 9 : Interactive definition of the proper branch of the arcsin-function by program A4A.



DATE 14-JAN-74  
SCHUSSNR 5202  
13:42:46 18-OCT-73

S. REHKER, D. ZIMMERMANN

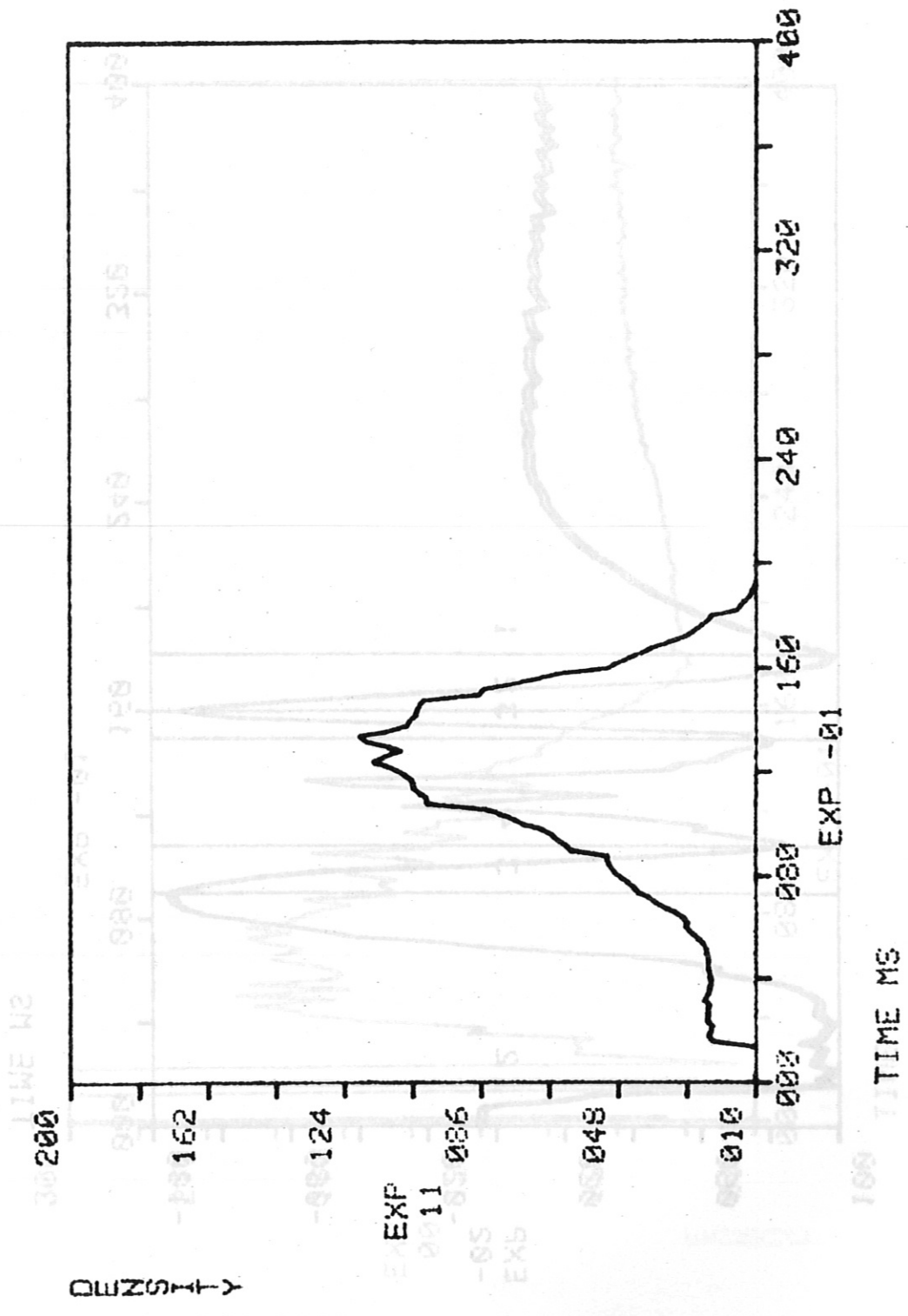

Fig. 10: Computed plasma density (Program A4B).

13:45:40 18-OCT-73  
SCHUSSNR 2505  
DATE 14-JAN-74

DATE 14-JAN-74  
SCHUSSNR 5202  
13:42:46

CURVE NB01  
18-OCT-73

S. REHKER, D. ZIMMERMANN

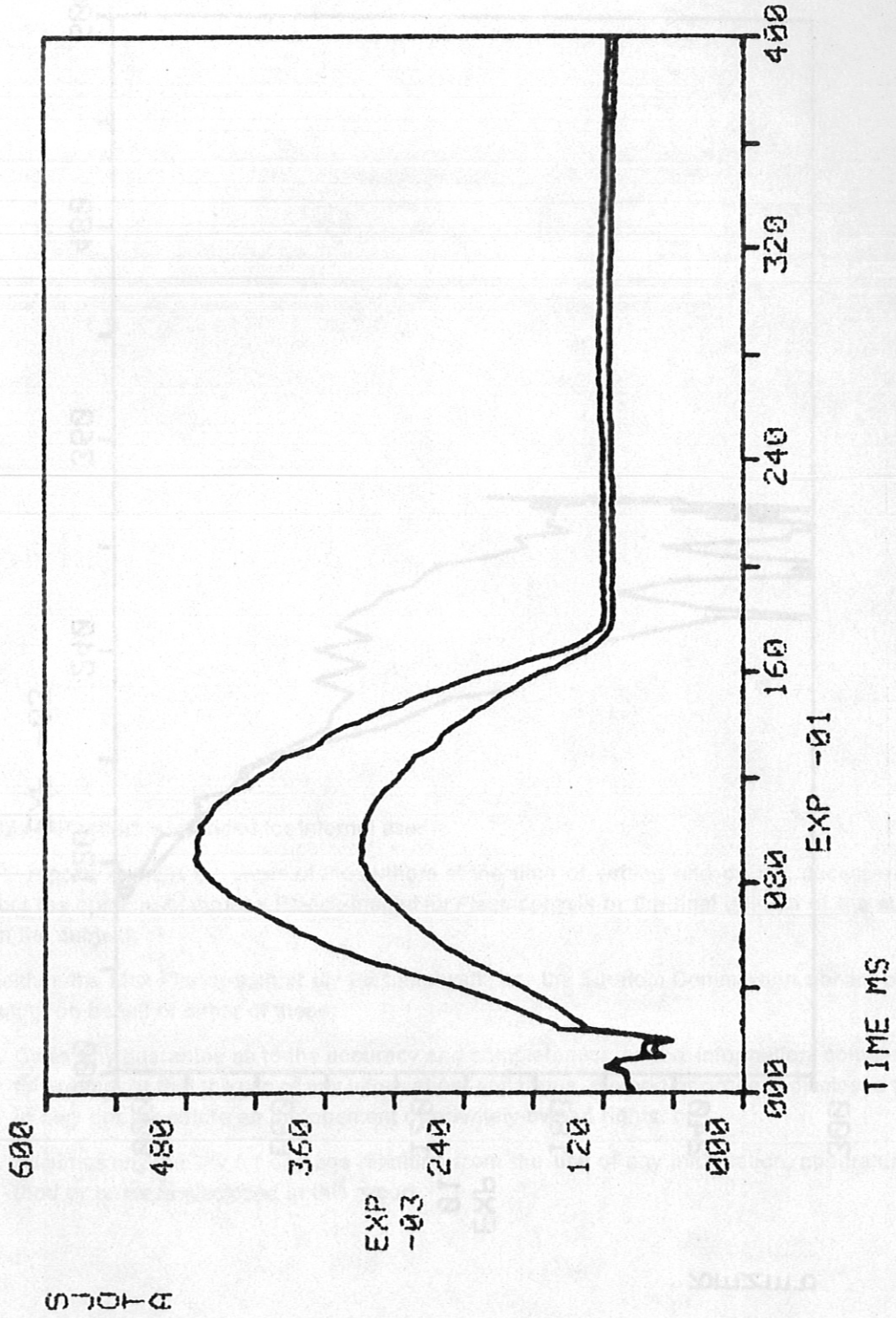

Fig. 11: Total rotational transform computed by program A5  
for two different plasma radii.

DATE 14-JAN-74  
SCHUSSNR 5202  
13:42:46 18-OCT-73

S. REHKER, D. ZIMMERMANN

PROGRAM A6

TIME W2

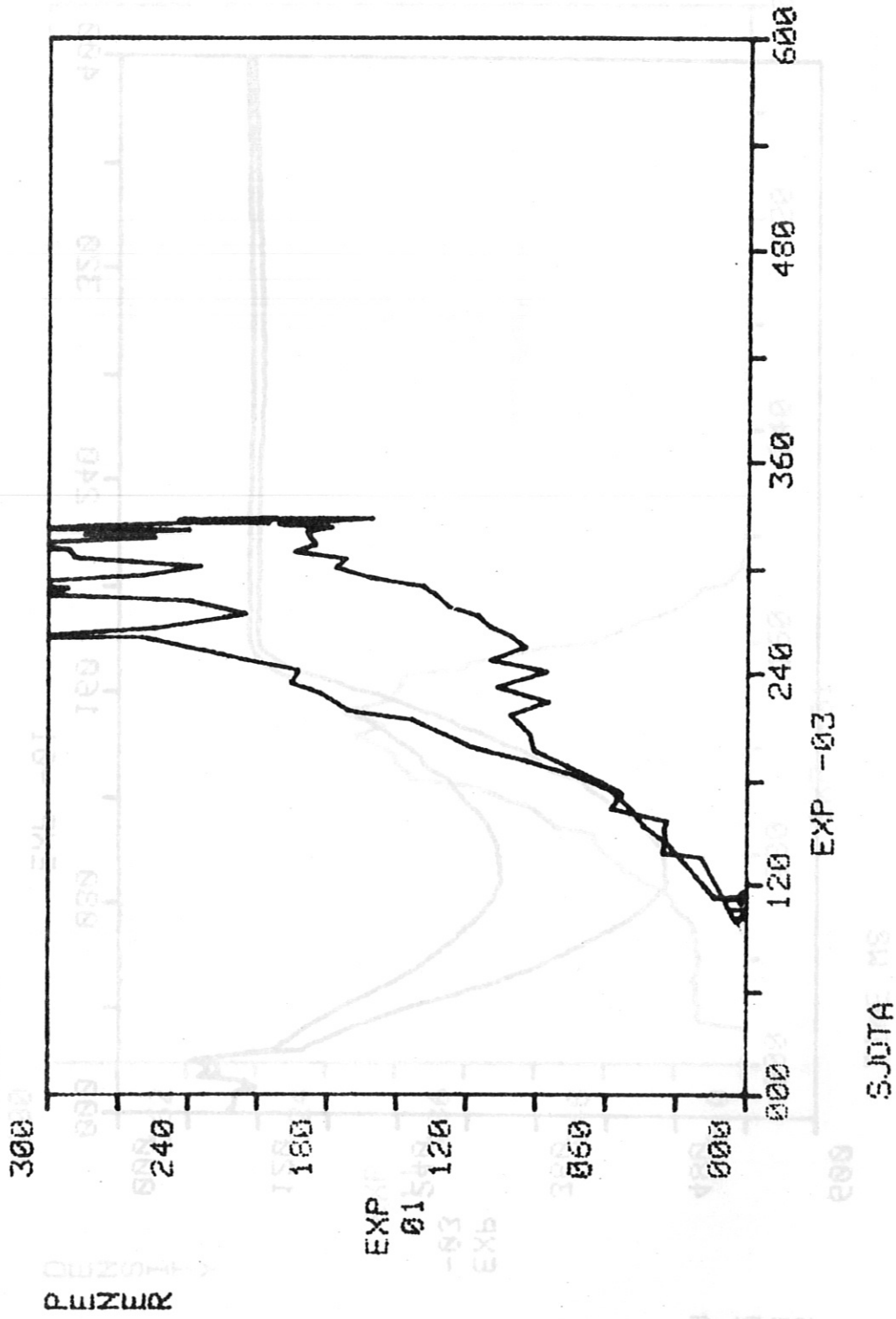

Fig. 12: Plot of plasmaenergy against total rotational transform by program A6.