

Measurement of the magnetic selffield
of a relativistic electron ring and the
evaluation of different ring properties,
especially the number of electrons.

C. Andelfinger

W. Herrmann

M. Ulrich

IPP 0/9

September 1971

MAX-PLANCK-INSTITUT FÜR PLASMAPHYSIK

GARCHING BEI MÜNCHEN

MAX-PLANCK-INSTITUT FÜR PLASMAPHYSIK
GARCHING BEI MÜNCHEN

Measurement of the magnetic selffield
of a relativistic electron ring and the
evaluation of different ring properties,
especially the number of electrons.

C. Andelfinger
W. Herrmann
M. Ulrich

IPP 0/9

September 1971

*Die nachstehende Arbeit wurde im Rahmen des Vertrages zwischen dem
Max-Planck-Institut für Plasmaphysik und der Europäischen Atomgemeinschaft über die
Zusammenarbeit auf dem Gebiete der Plasmaphysik durchgeführt.*

IPP 0/9

C. Andelfinger
W. Herrmann
M. Ulrich

Measurement of the magnetic selffield of a relativistic electron ring and the evaluation of different ring properties, especially the number of electrons.

Abstract

A method is described to determine the number of electrons in a ring during and after compression by measuring the selffield of the ring on axis. The accuracy of this method is mainly limited by the knowledge of the ring radius and in case of the evaluation of the \dot{B} signal by the compression velocity. Radial and axial dimensions of the ring minor cross section are of minor importance. Besides of the number of electrons particle losses and energy losses (additional compression) can be detected.

Introduction

The particle number in the Garching compression experiment^{1,2} has mainly been determined by Faraday cup measurements. These measurements have the disadvantage that results are obtained only by destroying the ring. Furthermore, the interpretation of the Faraday cup signals is very dubious because of scattering and secondary electron problems. The need for a diagnostic tool without the indicated disadvantages was apparent. The magnetic selffield of the ring seemed to offer a rather good solution to that problem, at least in cases, where the particle number in the ring is sufficiently high. The lowest particle number which can be measured, is the smaller, the better the field of the compressing coils can be compensated. Having the main measuring loop on axis in midplane one can measure the B and \dot{B} of the ring at each instant of time during the compression cycle without destroying the ring. It appears that the distance of the ring from the measuring loop on axis is always large enough to interpret the signals without an intolerable error, introduced by the unknown density distribution over the minor crosssection.

A. Evaluation of the particle number from \dot{B} and B

a) infinitely small minor ring radius

If we assume that the ring radius R is much larger than the loop radius r and the minor ring radius a one gets for the field on axis:

$$B = \mu_0 \frac{I}{2R} \quad [\text{MKSA units}]$$

The current I is related to the particle number N_e by:

$$I = \frac{e \cdot N_e \cdot c}{2\pi R}$$

This gives:

$$B = \frac{\mu_0 \cdot e \cdot N_e \cdot c}{4\pi R^2}$$

The voltage induced in the loop during compression is found to be:

$$V = \dot{B} \cdot r^2 \pi = - \frac{\mu_0 \cdot e \cdot N_e \cdot c \cdot r^2}{2} \cdot \frac{\dot{R}}{R^3}$$

This gives for the number of electrons:

$$N_e = - \frac{2}{\mu_0 \cdot e \cdot c \cdot r^2} \cdot \frac{R^3}{\dot{R}} \cdot V$$

Here V has to be measured and R and \dot{R} have to be determined from a calculation of compression in connection with a compression measurement. A 10 % error in R gives an about 30 % error in N_e . The error is less, when one integrates the induced voltage:

$$U = \frac{1}{\tau} \int V dt$$

Here we find:

$$N_e = \frac{4\tau}{\mu_0 \cdot e \cdot c \cdot r^2} \cdot U \cdot R^2$$

The particle number at the end of compression depends only on the square of the radius R and does not depend on \dot{R} .

A 10 % error in R gives an about 20 % error in N_e .

b) effect of finite minor ring radius

We first assume that the ring has only a finite extension in axial direction $L/2$ and that the current and density distribution is constant. We then get:

$$B_1 = \mu_0 I / (4R^2 + L^2)^{1/2}$$

L/R is nearly constant during compression, as long as no instabilities occur. An instability occurs at about $R \approx 0.09$ m and blows the ring up to $L \approx 0.06$ m. Then we get for the maximum error in B after ring blow up:

$$\frac{\Delta B}{B} \approx -\frac{L^2}{8R^2} \approx -5.5 \%$$

Because the particle distribution is surely more concentrated in midplane, the error is much less. Anyway: The field with finite dimension of the ring is less than with the infinitely small cross section. Therefore, evaluating the particle number with the assumption of infinitely small cross section gives a lower limit.

If the ring has a finite extension a in radial direction only one finds for constant density distribution over a :

$$B_2 = \frac{\mu_0 e c N_e}{4 \pi (R^2 - a^2)}$$

and

$$\frac{\Delta B}{B} \approx \frac{a^2}{R^2}$$

With $\frac{a}{R} \approx 0.1$ (corresponding to about 2 cm radial extension at injection) the field on axis is only 1 % larger than in the case with $a = 0$. This effect is surely negligible as long as instabilities do not produce a total redistribution in radial amplitudes or energy.

So far to the errors for the flux measurement. In the case of the interpretation of the \dot{B} signal we get for axial extension:

$$\frac{\Delta \dot{B}_1}{\dot{B}_1} \approx -\frac{L^2}{8R^2} \approx -5.5 \%$$

as long as L/r is constant. Because the field index changes during compression, this might alter the accuracy limit a little bit. As in the case of the B signal the real error is probably smaller than 5.5 % and the particle number evaluated with the assumption of zero axial extension gives a lower limit.

For the radial extension we find the same error as in the flux measurement, as long as $a/R \approx \text{constant}$. If due to an instability the amplitudes of the ring change, it should be possible to detect this sensitively in the \dot{B} signal. Increasing axial amplitude reduces \dot{B} ; if the radial amplitude increases, \dot{B} grows slightly.

c) ring field seen by the compensating loop

We finally have to consider the effect of the compensating loops. One of these loops (see below) was on axis, at $z = 0.2$ m off midplane. How large is the field and the field change seen by this loop? We assume in this case that the minor dimension of the ring is zero.

$$B_1 = \frac{\mu_0 \cdot I}{2R \left(1 + \frac{z^2}{R^2}\right)^{3/2}}$$

and

$$\frac{B_1(z, R)}{B_0(z=0, R)} = \left(1 + \frac{z^2}{R^2}\right)^{-3/2}$$

For $R = 0.053$ m (end of compression with two coil pairs only) we find

$$\frac{B_1}{B_0} = 1.6 \%$$

This is a negligible error.

For the case of \dot{B} we obtain:

$$\frac{\dot{B}_1}{\dot{B}_0} = \left(1 + \frac{z^2}{R^2}\right)^{-3/2} \cdot \left[1 - \frac{3}{4} \left(1 + \frac{z^2}{R^2}\right)^{-1/2} \cdot \frac{z^2}{R^2} \right]$$

In Fig. 1 we see \dot{B}_1/\dot{B}_0 as a function of R. The error is large for large radii. But for $R < 0.15$ m we get an error of less than about 4 %. Because the signal of the compensating loop is subtracted from the signal of the measuring loop, the effectively measured \dot{B} is too small for radii $R > 0.13$ m and is too large for $R < 0.13$ m.

Altogether it seems justified to evaluate the number of electrons from the simple formula of an infinitely thin ring: The largest errors are introduced by the uncertainty in the determination of R and \dot{R} .

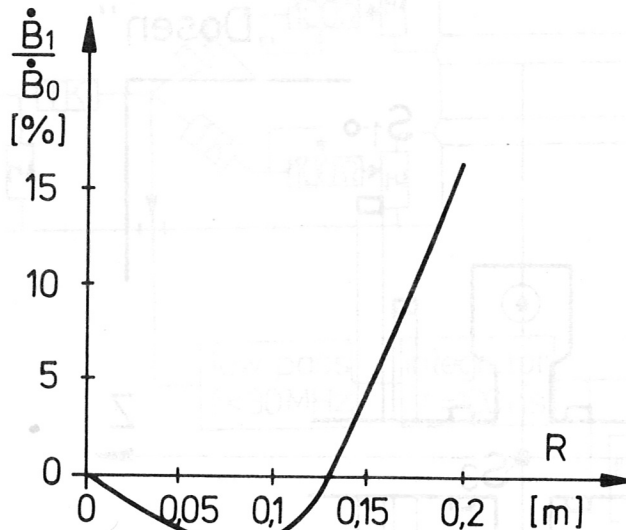

Fig. 1 Ratio of the time derivative of the field in the compensating loop to the measuring loop.

B. Experimental arrangement

a) Compensation of the main magnetic field

The magnetic selffield of the electron ring was measured in the midplane on the axis by a pick-up loop (see Fig. 2). The field there is composed of the compressor field (due to the currents in coil 1 and coil 2) and by the current of the electron ring. It can be described as a linear combination of these three currents.

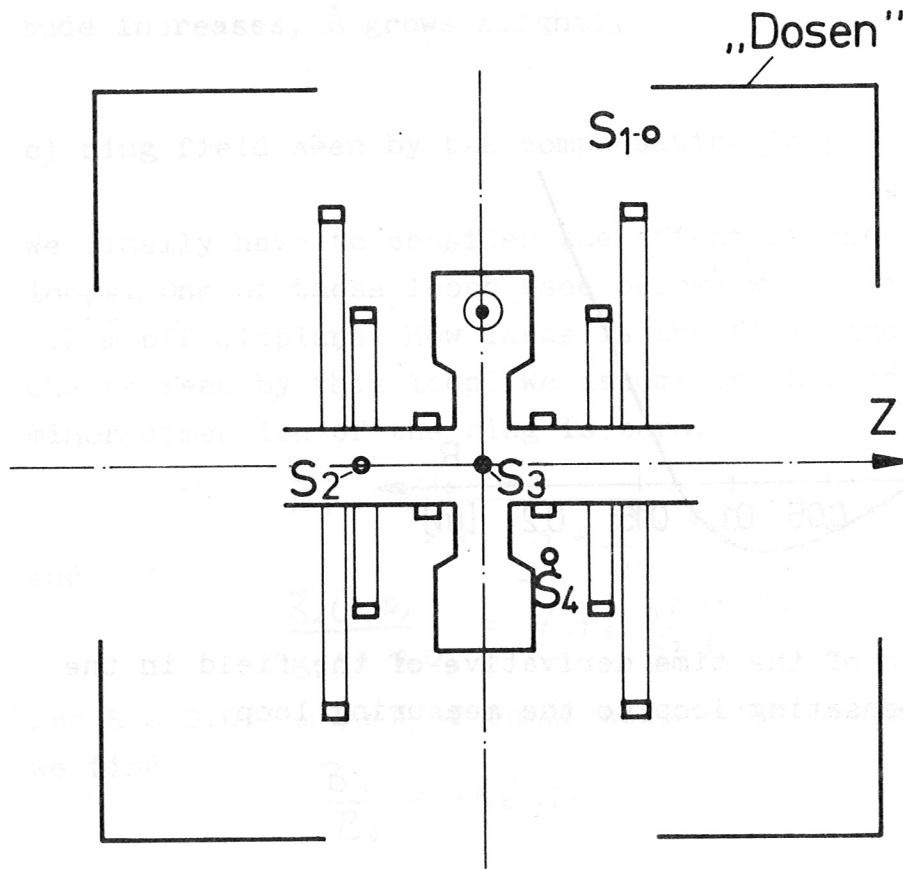

Fig. 2 Experimental set up

Since \dot{B}_{ring} is small ($\approx 1\%$) compared to $\dot{B}_{compr.}$ compensation for $\dot{B}_{compr.}$ is necessary (Fig. 3). Because of the linear combination of the field, produced by several current circuits, the same number of compensation loops is necessary. Adding these signals (with proper amplitude and phase) to the \dot{B} -signal obtained in midplane on the axis gives the desired \dot{B}_{ring} . Since it is very difficult with our compressor to get \dot{B} -signals proportional to the current of a single coil pair only, we used an arrangement of three pick-up loops (S_1, S_2, S_3) as shown in Fig. 2.

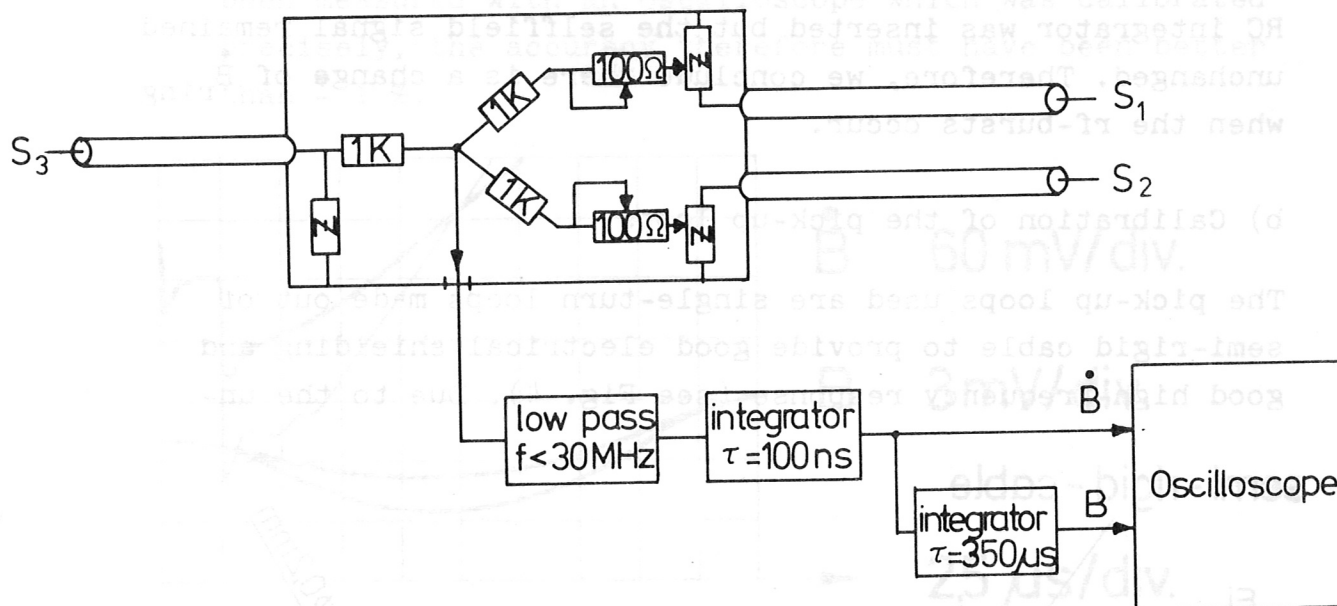

Fig. 3 Compensating network

S_3 gives the combined \dot{B} -signal; the signal from S_2 is dominated by coil pair 2 and the signal from S_1 by coil pair 1. Taking the proper amplitude from S_1 and S_2 one gets good compensation of the compressor field-components induced in S_3 . The voltage of S_1 and S_2 induced by the ring was calculated and is used for correction (see above).

By taking an oscillogramme (see Fig. 6) of the compensated signal with the ring present and another one without a ring, the difference of the two signals gives \dot{B}_{ring} , if corrected by a few percent as mentioned above.

Another pick-up loop (S_4) was used to detect rf-bursts. When the number of inflected electrons was high, bursts could be seen with amplitudes up to 100 V and frequencies between 250 Mhz and 1,1 GHz. Since these bursts were also seen by the loops S_1 , S_2 , S_3 , the compensated signal for selffield measurement was fed through a L-C low pass filter to prevent signal distortion due to rectification in the oscilloscope. In spite of filtering, the \dot{B} -signal of the selffield showed deviations from the expected curve exactly at the time the rf-burst occurred. To ensure these deviations are not due to a rest of rf, that might have passed the filter, an additional RC integrator was inserted but the selffield signal remained unchanged. Therefore, we conclude there is a change of \dot{B}_{ring} when the rf-bursts occur.

b) Calibration of the pick-up loops

The pick-up loops used are single-turn loops made out of semi-rigid cable to provide good electrical shielding and good high-frequency response (see Fig. 4). Due to the un-

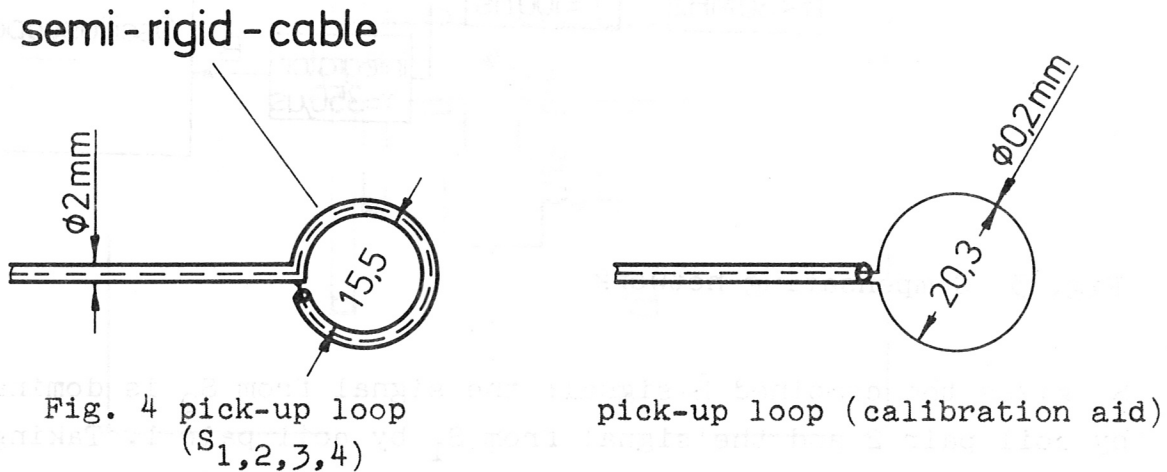

known eddy currents in the shield of the loop, the effective loop area could not be calculated from the loop dimensions. The effective area was found experimentally by comparison with a loop of wellknown area. Both loops were brought

between Helmholtz-coils where the uniformity of the field was better than 0.2 %. The frequency used was the frequency of our compressor field to ensure comparable penetration effects. The comparison gave an effective loop area of 2.32 cm² and a sensitivity of the loop

$$S = \frac{\dot{B}}{U_i} = \frac{\omega B}{F \cdot \omega \cdot B} = 43,2 \cdot 10^6 \left[\frac{\text{Gauss}}{\text{Vs}} \right].$$

In order to test the accuracy of this result, the sensitivity of this loop was also calculated with the absolute values of the test field and the loop area. The results of both methods deviate by 1 % only. The absolute values ($J_{\text{Helmholtz}}$, f , U_i) have been measured with an oscilloscope which was calibrated precisely, the accuracy therefore must have been better than ± 1 %.

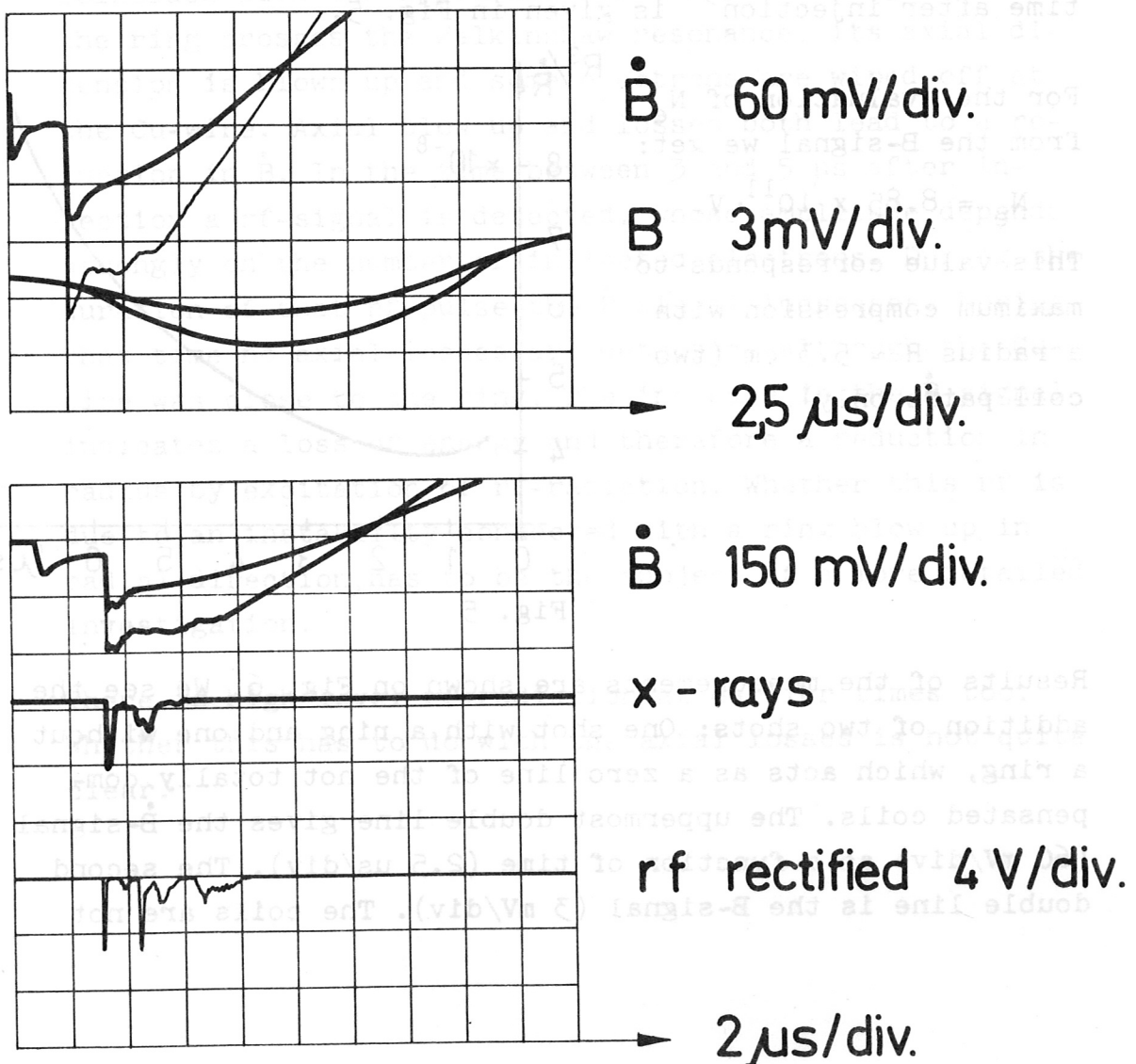

Fig. 6 Selffield signals, losses and rf-bursts

C. Discussion of the results

If we use the effective area of the measuring loop ($F = 2.32 \times 10^{-4} \text{ m}^2$) we find for the evaluation of N_e from the \dot{B} signal:

$$N_e = 4,5 \cdot 10^{20} \cdot \frac{R^3}{\dot{R}} \cdot U_i$$

Our earlier measured compression curves are in good agreement with the calculated ones. Because the energy in the ring covers a region between 1.7 and 1.9 MeV, we calculated R^3/\dot{R} for the average value of 1.8 MeV. The thereby caused deviation from the real value might be of the order of 5 % in the radius and about 15 % in $N_e \cdot R^3/\dot{R}$ as a function of time after injection³ is given in Fig. 5.

For the evaluation of N_e from the B-signal we get:

$$N_e = 8.85 \times 10^{11} \cdot v.$$

This value corresponds to maximum compression with a radius $R = 5.3 \text{ cm}$ (two coil pairs only).

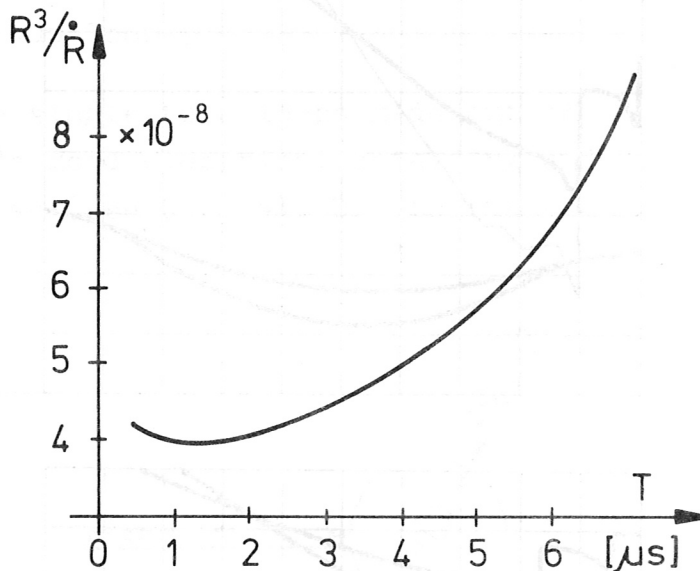

Fig. 5

Results of the measurements are shown on Fig. 6. We see the addition of two shots: One shot with a ring and one without a ring, which acts as a zero line of the not totally compensated coils. The uppermost double line gives the \dot{B} -signal (60 mV/div) as a function of time (2.5 μs /div). The second double line is the B-signal (3 mV/div). The coils are not

crowbarred in this case and the ring expands immediately after maximum compression. Maximum compression is achieved at the moment when the \dot{B} -signal crosses the zero line. The B -signal is rather smooth. The particle number at maximum compression is $N_e = 1.63 \times 10^{12}$. The \dot{B} -signal shows an interesting structure during the first 5 μ s after injection. We see minima and maxima. The third double line repeats the \dot{B} -signal on another scale (150 mV/div and 2 μ s/div). Related to these signals on the same time scale are x-rays in arbitrary units coming from a Cu-wire, which extended from $R = 5$ to $R = 20$ cm at $z = 3$ cm and rectified high frequency radiation (\approx GHz) detected with a loop S.4 shown on Fig. 2. The x-rays indicate axial losses⁴. The first minimum in \dot{B} coincides with the appearance of x-rays. During that time the ring crosses the Walkinshaw resonance, its axial dimension is blown up and some electrons are wiped off at the Cu-wire. Axial blow up and losses both lead to a reduction in \dot{B} . In the time between 3 and 5 μ s after injection a rf-signal is detected, whose amplitude depends strongly on the number of inflected electrons. During the duration of that rf-pulse the \dot{B} -signal increases. During that time no axial losses are detected, although the Cu-wire was close to the ring. The increase in the \dot{B} -signal indicates a loss of energy and therefore a reduction in radius by excitation of rf-radiation. Whether this rf is due to an instability connected with a ring blow up in radial direction, has to be the subject of a more detailed investigation.

There is high level rf-radiation at earlier times too. Whether this has to do with the axial losses is not quite clear.

Evaluating the \dot{B} -signal at $T = 2.5; 5; 7.5 \mu s$ after injection gives $N_e = 1.85 \times 10^{12}; 1.9 \times 10^{12}; 1.8 \times 10^{12}$. The number obtained from the B-signal was about 10 % less. The pulse of the injected current had a maximum of 70 A. Therefore, it was possible to deflect effectively a number of electrons corresponding to one turn (4 ns). This is in good agreement with the calculated action of the inflector.

The number of electrons determined by this method is by at least a factor of 2 larger than obtained from Faraday cup measurements. It is assumed that electrons striking the Faraday cup during compression, are scattered to rather large angles. The number of electrons measured by the Faraday cup depends under these circumstances on the field index and the axial distance of the walls.

Summary

A device has been described, with which it is possible to measure the selffield of a relativistic electron ring and to determine the number of electrons in the ring with rather good accuracy. The number of electrons found in the ring corresponds to about one turn of the injected electron beam. This is in agreement with the calculated performance of the inflector. The measurement of the selffield offers a good possibility to avoid the errors of the Faraday cup, to measure the particle number without destroying the ring and to get absolute values for the particle number without good knowledge of the rings minor dimensions. Moreover, it is possible to detect particle losses and energy loss of the ring electrons.

Acknowledgment:

We are glad to point to the fact that Dr. U. Schumacher has proposed this possibility to measure N_e . He started preliminary measurements before he left for a longer visit in Berkeley.

References:

- 1 C. Andelfinger et al.: Contribution to the 3rd Work Meeting on Electron Ring Accelerators 1969
Kernforschungszentrum Karlsruhe 3/69-30
- 2 C. Andelfinger et al.: Proceedings of the 4th Work Meeting on Electron Ring Accelerators 1971
IPP 0/3, 1971
- 3 For the calculation of this function we are indebted to A.U. Luccio
- 4 C. Andelfinger et al.: IPP 0/8, 1971.