

**MAX-PLANCK-INSTITUT FÜR PLASMAPHYSIK**  
**GARCHING BEI MÜNCHEN**

A Simulation Study of an  
On-Line Terminal System using Concentrators

R. A. Pocock

IPP R/1

July 1971

*Die nachstehende Arbeit wurde im Rahmen des Vertrages zwischen dem  
Max-Planck-Institut für Plasmaphysik und der Europäischen Atomgemeinschaft über die  
Zusammenarbeit auf dem Gebiete der Plasmaphysik durchgeführt.*

IPP R/1

R.A. Pocock

A simulation study of an  
on-line terminal system  
using concentrators

July, 1971 (in English)

**ABSTRACT:**

An on-line system consisting of 30 visual display consoles connected by 8 telephone lines to an IBM 360/91 computer is considered. A device known as a concentrator is used to connect several terminals to one or more telephone lines. Many possible configurations are simulated, and conclusions drawn as to the best configuration with regard to cost and performance.

## INTRODUCTION

The aim of this study is to simulate various possible configurations of an on-line terminal system, consisting of 30 visual display consoles, connected by 4800 baud telephone lines to an IBM 360/91 computer.

In a simple on-line terminal system terminals are usually connected one per telephone line, and the lines are connected via a multiplexed I/O channel directly to the computer (Fig. 1). In the Institut für Plasmaphysik a more complex system is being considered, where a device, known as a concentrator, is connected between several terminals and one or more telephone lines. This reduces the number of costly telephone lines required, and is therefore an advantage in such a system as long as the performance is not impaired under normal operating conditions.

Several types of concentrator exist, designed to be connected to 1, 2, 3 or 4 telephone lines (Fig. 2 (a), (b), (c), (d) ). In the latter three cases the concentrators are buffered and capable of queuing requests from their terminals; the telephone lines connected to them may be used in parallel to service these requests. In case (a) the concentrator is not buffered and is merely a switch between the terminals and telephone line.

A simulation study was made of a system of 30 visual display consoles connected to concentrators of different types, so as to use 8 telephone lines. A system using 30 display consoles connected to 30 telephone lines without concentrators was also simulated for the sake of comparison. The results were analysed to determine the best configuration for an on-line system of this type taking into account the limitations of cost and possible physical distribution within the installation.

## ASSUMPTIONS

In all simulation studies a major problem lies in the definition of the model, since at the simulation stage very little is usually known about the system. In this simulation the following basic assumptions were made:

- 1) The system consisted of 30 terminals.
- 2) The terminals were connected to 8 telephone lines.
- 3) The transmission speed of the lines was 4800 baud (i.e. 600 bytes/sec).
- 4) Since the multiplexed I/O channel has a speed of approximately  $4 \times 10^4$  bytes/sec it can never be busy on average even if all the telephone lines are completely full. It has thus been ignored in this study.
- 5) The time taken to transmit a polling message along one telephone line is 40 m.secs (i.e. 10 m.secs switching time plus 30 m.secs to transmit 10 bytes of question-and-answer information in each direction). It should be noted here that each terminal on a simple switch-type concentrator (Fig. 2 (a)) must be polled separately, whereas the buffered concentrators (Fig. 2 (b),(c),(d)) hold a queue of terminal requests and may be polled as one unit.
- 6) Messages from the computer have a higher priority than those to it.
- 7) Messages typed in on the display terminal for transmission to the computer have a Poisson distribution in length with a mean of 12 characters, and a maximum length of 80 characters.
- 8) Message responses returned from the computer are of

three types distributed as follows:

- (a) 70 % of messages are "full-screen" of 1200 characters (e.g. program listing).
  - (b) 20 % are randomly distributed in length between 1 and 1200 characters (e.g. listing a few lines of program).
  - (c) 10 % have a length distribution as in section 7) above (e.g. replies to STATUS requests etc.).
- 9) The central processing unit (CPU) takes an average elapsed time of 300 m.secs to process a message (CPU time may be much less). Actual processing times are randomly distributed between 150 and 450 m.secs. This represents approximately the message-handling times of the AMOS on-line terminal software system which will run the display consoles.

#### POLLING OF TERMINALS

The simulation program used to simulate the model was the General Purpose Simulation System/360 (GPSS/360). In the first runs it was thought necessary to simulate the polling of the display terminals accurately, by simulating polling messages which could only be transmitted along the lines when these were not transmitting messages. This method was found to be extremely inefficient and caused GPSS to use excessive CPU processing time. Therefore in subsequent runs average times were assumed for the time taken for a polling message to release a message from a display console, this time being calculated depending on the type of concentrator.

This approximation was found to give no significant difference in results for the turn-around times of messages, which is

to be expected, since polling merely controls the order in which events are processed. On average both methods give random message processing when several thousand messages are considered. The second method was 200 times more efficient in its use of CPU time by GPSS.

### SIMULATION TESTS AND RESULTS

The flowchart of the program used to simulate the on-line system is shown in Figure 3. The time between messages generated by the terminals had a Poisson distribution with a mean which was varied from test to test.

Various configurations were simulated:

- a) 30 lines each with 1 terminal (no concentrator)
- b) 8 concentrators each with one line and 4 terminals (one concentrator with only 2 terminals)
- c) 4 concentrators each with 2 lines and 8 terminals (one concentrator with 6 terminals)
- d) 3 concentrators with 3,3 and 2 lines and 12,12,6 terminals respectively
- e) 2 concentrators with 4 lines, one having 16 the other 14 terminals
- f) 5 concentrators as follows:
  - 1 with 4 lines and 14 terminals
  - 4 with 1 line and 4 terminals.

Polling times (i.e. the time added to the turn-around time of a message to allow for the time taken for it to be "sensed" by the CPU) were worked out as follows:

- a) For concentrators with 1 line (i.e. switches)  
40 m.secs/message (i.e. per terminal)

b) For concentrators with more lines (buffered)

$$\frac{40 \text{ m.secs}}{\text{number of lines on the concentrator}} / \text{message}$$

### TEST 1

Three sets of simulations were made with the average time between console messages being 0.3, 0.4 and 0.35 secs throughout the whole system (this represents 1 message every 9, 12, and 10.5 secs respectively per terminal). In each case all of the above configurations were simulated. Results are tabulated in Table 1.

10,000 messages were simulated in each case (representing approximately 1 hour of simulated real-time). After 5000 messages the turn-around time per message was measured every 1000 messages to see if the system was stable or if queues were slowly building up. The results were plotted in Figure 4.

It may be noted that for message rates between 1 message/12 secs/terminal and 1 message/9 secs/terminal queues rapidly build up, and that in the latter case turn-around time is increasing steadily even after 10,000 messages. The results also show that at 1 message/9 secs/terminal the average use of a line (i.e. time in use divided by total available time) is between 0.5 and 0.7, and the average use of a terminal (i.e. time blocked waiting for a reply divided by total available time) is between 0.5 and 0.8. However, the CPU is in use nearly 100 % of the available time, and it is obviously here that the bottleneck in the simulated system lies.

### TEST 2

Secondly, the effect of the number of terminals on a particular concentrator was investigated. A message rate of 1 message/10.5 secs/terminal was chosen, since this is the threshold

message rate for the building up of permanent queues.

In all cases the simulated system again had 8 telephone lines and 30 terminals, but the types of concentrators and number of terminals per concentrator were varied in each configuration. The turn-around time for a particular concentrator/terminal group was found to be independent to a large extent of the configuration of other groups within the system. The results are shown graphically in Figure 5, in which concentrator line usage (as defined in Test 1) is plotted against number of terminals on the concentrator for each of the different concentrator types.

### TEST 3

Lastly, the effect of reduction of CPU processing time was investigated. The mean processing time was reduced to 100 m.secs and the spread to  $\pm$  50 m.secs. The initial configuration of Test 1 were used and message rates of 1 message/6 secs./terminal and 1 message/9 secs./terminal simulated. Results are shown in Table 2, from which it may be seen that at the former rate both the lines and terminals are blocked, but the CPU is only being used 50 % of the time. At the latter rate the lines are in use 70 % of the time, the terminals 20-50 % of the time and the CPU 33 % of the time.

### CONCLUSIONS

In the system simulated in Test 1 the bottleneck is obviously the CPU processing time assumed, which is quite realistic for the AMOS on-line software system. Queues begin to build up at 1 message/10.5 secs/terminal due to this limitation. However, it should be noted (and is shown by Test 3) that there is little to be gained by reducing the CPU processing time drastically, due to the basic limitation of line speed.



The time taken to process a message which does not have to queue at all may be calculated roughly as 2.04 secs. (0.04 secs poll waiting time + 1.7 sec transmission time + 0.3 secs CPU processing time). If 4 terminals are assumed per concentrator line this implies an approximate maximum message rate of 1 message/8.2 secs/terminal, this maximum being mainly governed by line speed. Even if CPU processing time is reduced to zero, only an approximate maximum rate of 1 message/7.0 secs/terminal is possible.

From Figure 4 it is clear that very little difference exists between the different configurations at 1 message/10.5 secs/terminal. The maximum difference is 30 % of the turn-around time. At 1 message/9 secs/terminal large differences become apparent as queues build up, but these differences are not particularly relevant as the system is rapidly becoming unworkable.

It should be noted particularly that no operator at the display console is capable of keeping up a sustained typing rate of greater than 1 message/15 secs/terminal on average, and thus Tests 1 and 3 imply little advantage in the more expensive multi-lined concentrators, or in CPU processing time reduction.

Test 2 gives an idea of the most suitable number of terminals to employ on a given concentrator. It shows that when this number exceeds a certain value the lines rapidly become blocked at the message rates assumed. The optimum number of terminals/concentrator is as follows:

- a) 3-5 on a 1 line concentrator (switch)
- b) 10 on a 2 line concentrator
- c) 15 on a 3 line concentrator
- d) 20-25 on a 4 line concentrator

If one concentrator may be used much less than another of the same kind it may have more terminals connected to it, since one concentrator is virtually independent of another. There is no advantage in having less terminals on a concentrator than specified above, since line speed still limits turn-around.

In conclusion, there seems little advantage in the 2-4 line buffered concentrators, which are expensive, over the unbuffered 1 line switch-type concentrators which are cheap. The latter have an obvious advantage over a system with 30 telephone lines and no concentrators, since the number of costly telephone lines is reduced without performance being significantly impaired. Thus the best solution for the configuration of such an on-line system appears to be a system using switch-type concentrators with 3-5 terminals per concentrator, this number depending on the physical lay-out required.

Terminal system turn-around (TEST 1)

Table 1

secs/mess	Lines/conc	Tem/conc	Av use of line	Av use of terminal	Av Q time at terminal	CPU use	Turnaround in secs after n messages				
							6000	7000	8000	9000	10000
0.3	1(x8)	4...4,2	0.67 0.32	0.81 0.64	45 8.7	.99	24.61	27.29	29.77	30.54	30.37
"	2(x4)	8,8,8,6	0.65 0.5	0.72 0.65	18 16	.98	13.71	16.59	20.1	23.09	26.4
"	3,3,2	12,12,6	0.64 0.64	0.70 0.70	12 12	.99	12.51	12.20	14.0	15.21	16.5
"	4,4	16,14	.64 .58	0.61 0.6	12 11	.99	10.49	9.75	10.95	12.21	13.13
"	4,1,1,1,1	14,4...4	.58 .67	0.54 0.7	7 18	.99	14.07	14.52	14.48	14.61	15.26
"	NONE	NONE	-	.81	20	.99	19.61	21.25	21.90	22.12	22.11
0.4	NONE	NONE	-	0.23	2.0	.74	3.31	3.29	3.29	3.30	3.30
"	1	4...4,2	0.5 2.4	0.25 0.2	2.8 1.7	.74	3.90	3.90	3.87	3.93	3.88
"	2	8...8,6	.49 .38	0.21 0.2	1.8 2.0	.75	2.92	2.99	2.96	2.96	2.93
"	3,3,2	12,12,6	0.51 0.37	0.2 0.2	1.7 1.8	.76	2.79	2.78	2.78	2.78	2.77
"	4	16,14	0.5 0.46	0.2 0.19	1.8 1.7	.77	2.68	2.73	2.73	2.71	2.71
"	4,1,1,1,1	14,4...4	0.44 0.5	0.19 0.26	1.7 2.6	.75	3.26	3.28	3.27	3.28	3.30

Table 1

Secs/mess	Lines/conc	Tem/conc	Av use of line	Av use of terminal	Av Q time at terminal	CPU use	Turnaround in secs after n messages				
							6000	7000	8000	9000	10000
0.35	none	none	0.3	0.3	2.7	0.86	4.15	4.14	4.08	4.0	4.19
"	1	4...4,2	0.59 0.28	0.38 0.27	4.4 2.3	0.86	5.42	5.46	5.49	5.38	5.40
"	2	8...8,6	0.58 0.43	0.29 0.27	3.4 2.8	0.87	3.86	3.91	3.95		
"	3,3,2	12,12,6	0.57 0.43	0.28 0.28	2.6 2.6	0.86	3.78	3.72	3.66	3.63	3.55
"	4	16,14	0.58 0.5	0.27 0.26	2.5 2.4	0.87	3.45	3.37	3.37	3.33	3.33
"	4,1,1,1,1	14,4...4	0.51 0.56	0.36 0.27	2.3 4.0	0.86	4.41	4.35	4.43	4.36	4.35

Table 2 Turn-around with reduced CPU processing time (TEST 3)

secs/mess	Lines/conc	Tem/conc	Av use of line	Av use of terminal	Av Q time at terminal	CPU use	Turnround in secs after n messages					
							6000	7000	8000	9000	10000	
0.2	0	none	-	.4	2.0	.51	31.2	31.4	31.7	31.5	31.5	31.5
"	1	4...4,2	.97 .53	.93 .4	27 2.6	.48	35.4	38.6	41.2	43	48.2	
"	2	8,8,8,6	.98 .76	.90 .45	25 3.0	.49	21.6	23.3	25.5	27.3	30	
"	3,3,2	12,12,6	.98 .78	.94 .50	35 4.5	.50	30.53	33.86	37	40.5	44	
"	4	16,14	.98 .91	.90 .56	60 4.8	.51	22.16	25.4	28.2	31.3	34.4	
"	4,1,1,1,1	14,4...4	.91 .96	.55 .90	5.4 30	.50	26	28.8	31	34.2	37	
0.3	0	none	-	.25	1.7	.34	2.67	2.69	2.70	2.70	2.71	
"	1	4...4,2	.67 .35	.34 .22	3.2 1.7	.34	4.32	4.26	4.22	4.12	4.14	
"	2	8,8,8,6	.68 .52	.26 .22	1.9 1.7	.34	2.68	2.68	2.68	2.70	2.67	
"	3,3,2	12,12,6	.67 .49	.22 .20	1.7 1.6	.33	2.3	2.34	2.35	2.34	2.35	
"	4	16,14	.67 .59	.21 .20	1.5 1.3	.34	2.11	2.12	2.13	2.13	2.13	
"	4,1,1,1,1	14,4...4	.60 .67	.20 .33	1.5 3.7	.34	3.27	3.21	3.20	3.19	3.17	

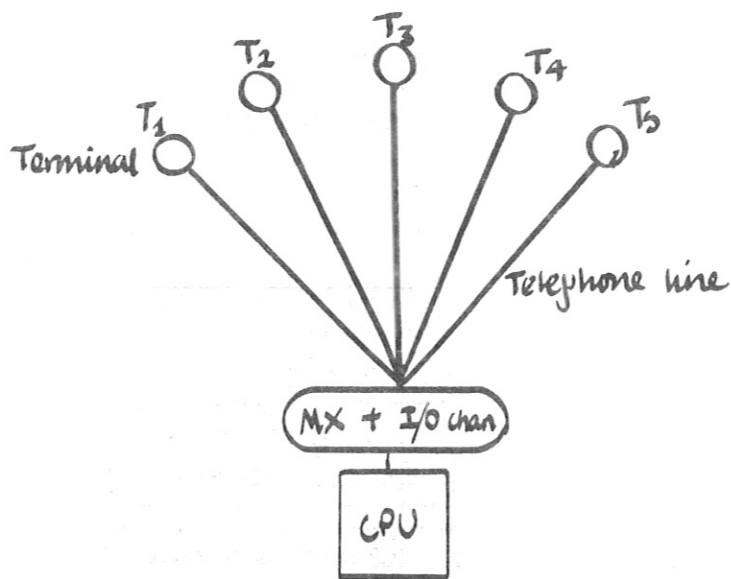
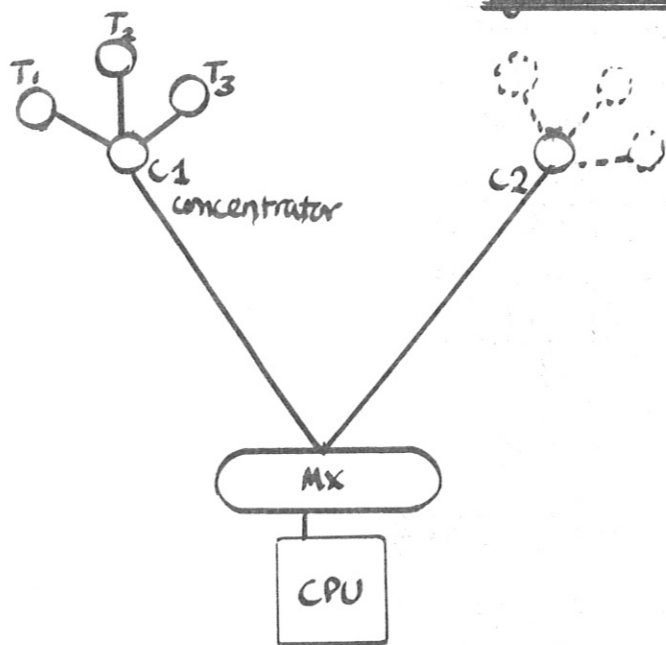
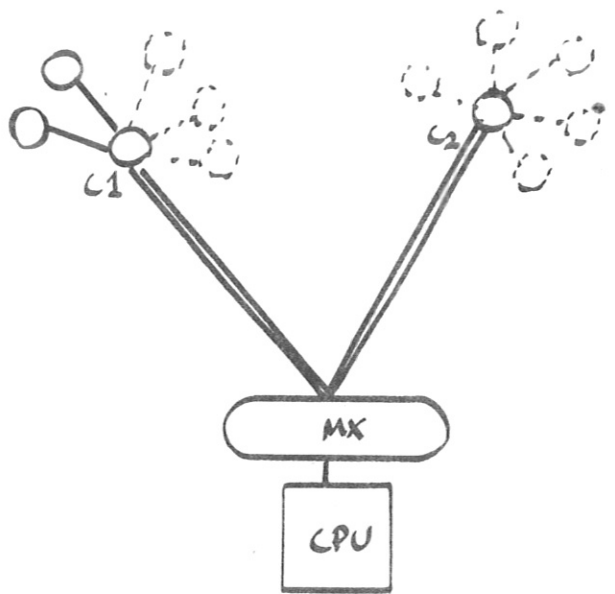

Fig. 1 Simple Terminal System



a) 1 line switch



b) 2 line concentrator

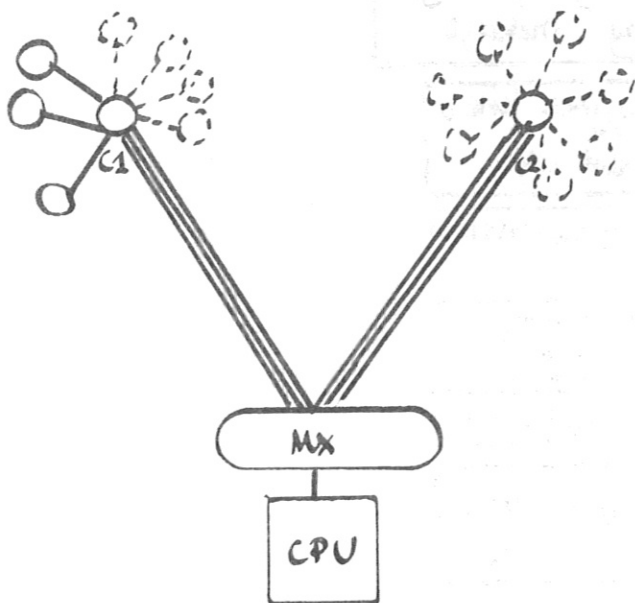

c) 3 line concentrator

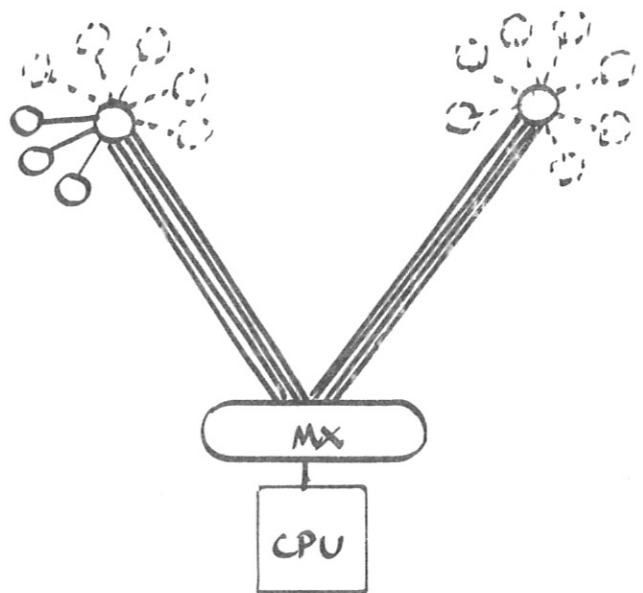

d) 4 line concentrator

Fig. 2 Terminal system with concentrators

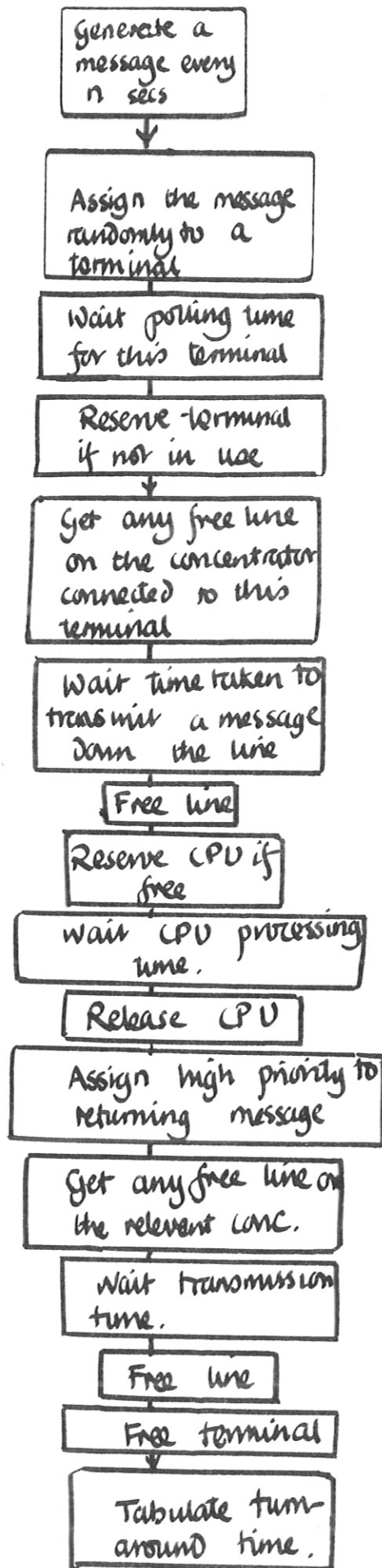
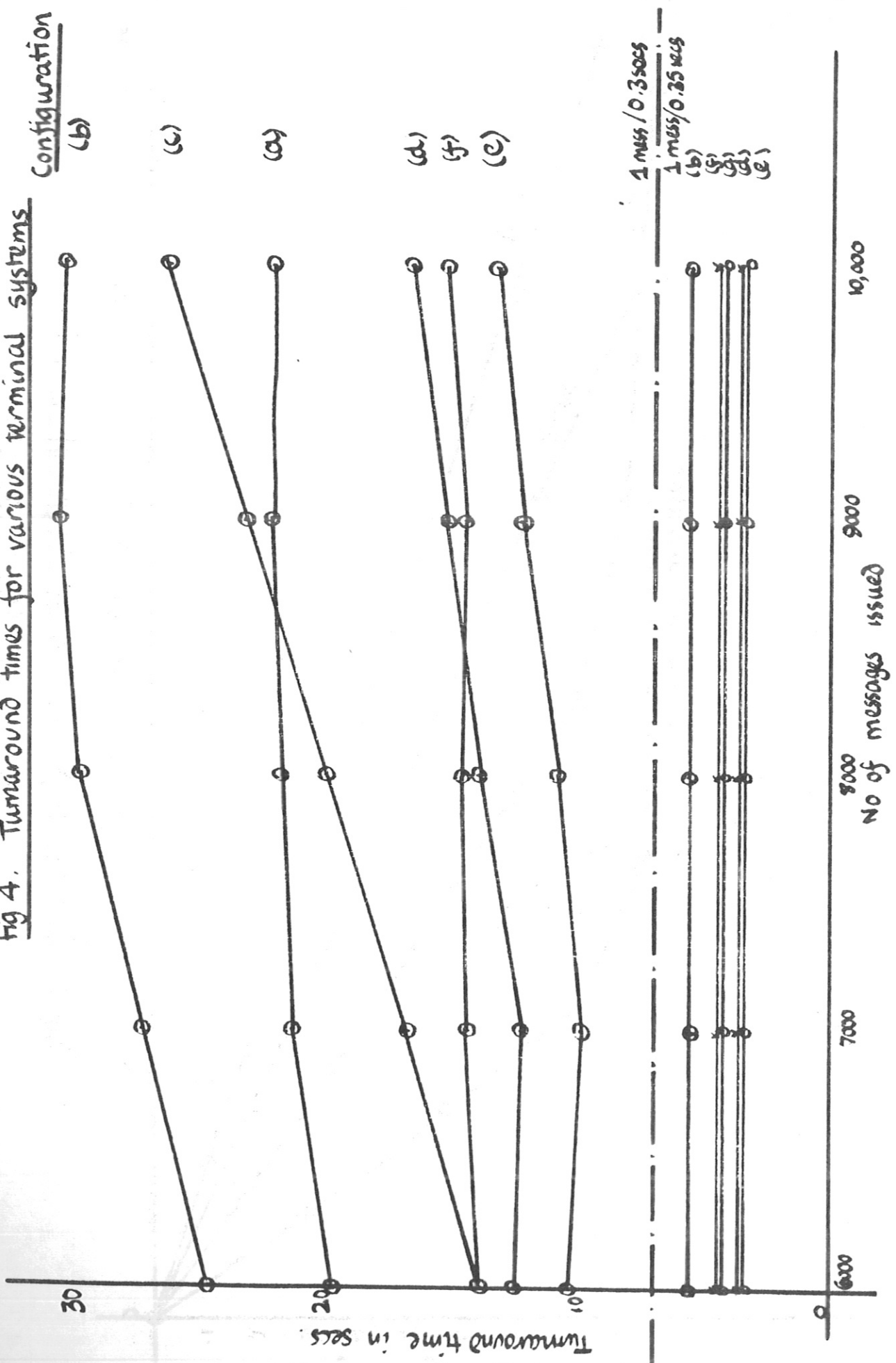

Fig. 3 GPSS Program Flowchart

Fig 4. Turnaround times for various terminal systems





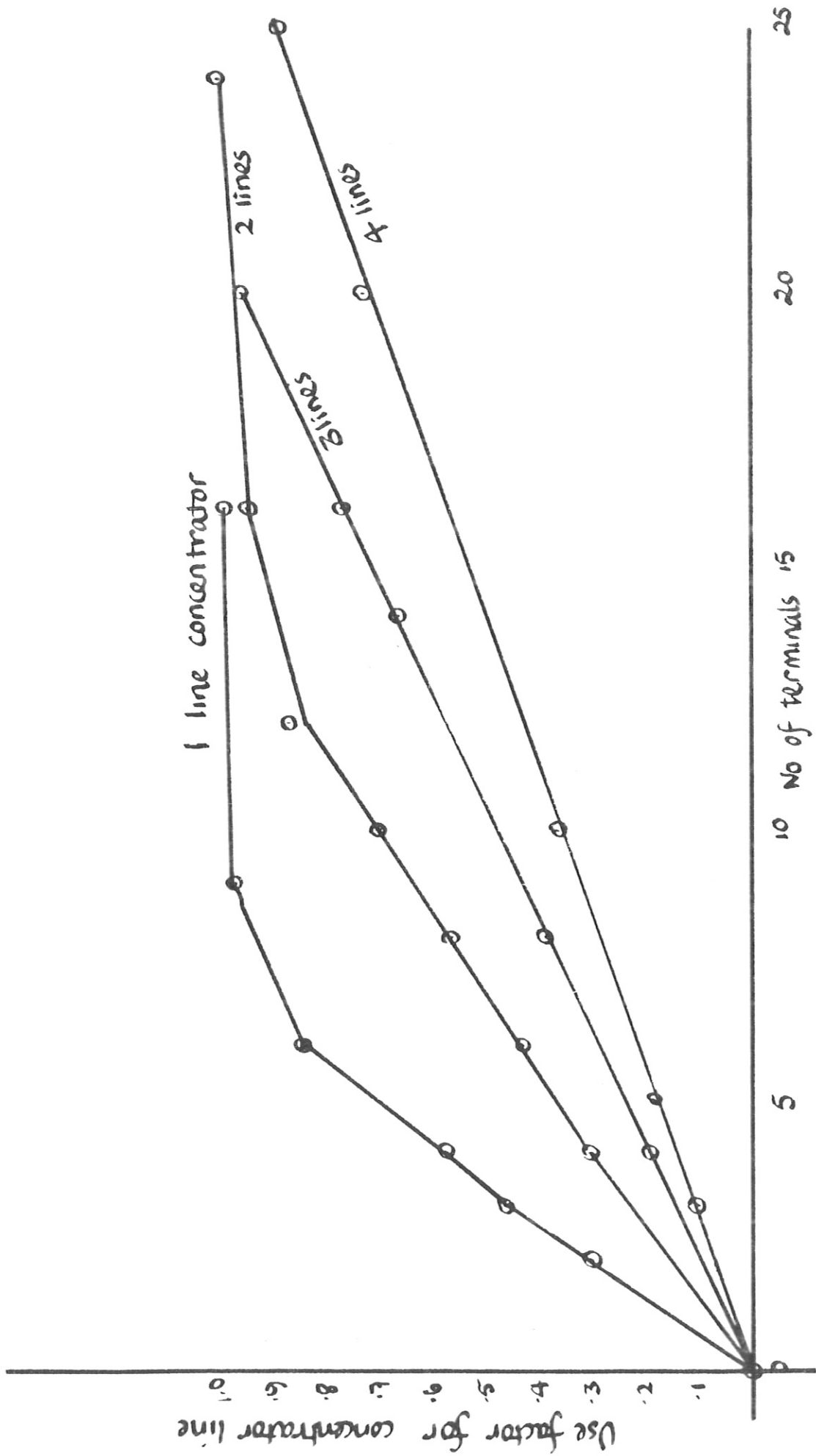

Fig 5 Line usage for various types of concentrator  
against number of terminals