

Technical Experience with
the Isar I Collector

E. Breit, A. Knobloch

IPP 4/65

June 1968

I N S T I T U T F Ü R P L A S M A P H Y S I K
G A R C H I N G B E I M Ü N C H E N

INSTITUT FÜR PLASMAPHYSIK

GARCHING BEI MÜNCHEN

Technical Experience with the Isar I Collector

E. Breit, A. Knobloch

IPP 4/65

June 1968

The contents of this report will be presented at the 5th Symposium on Fusion Technology at St. Catherine's College, Oxford, 2nd - 5th July 1968

Die nachstehende Arbeit wurde im Rahmen des Vertrages zwischen dem Institut für Plasmaphysik GmbH und der Europäischen Atomgemeinschaft über die Zusammenarbeit auf dem Gebiete der Plasmaphysik durchgeführt.

E. Breit, A. Knobloch

June 1968

Abstract

The collector arrangement of the linear theta pinch Isar I was described in Munich 1964. Since that time some experience has been gained with respect to operation, life time and improvements added.

The design principles are briefly reported. Whereas the precollectors have been in operation now over three years without damage, the highly stressed main collector and the coils have been subject to some failures and have been modified. We started with 30 kV ringing duty shots (1.5 MJ) and in one and a half year there were no breakdowns. When raising the energy to 2.7 MJ we got the current carrying sheets overstressed and had to increase the curvature radius at the coil feed edge. At the same time we added a collector extension and new coils shaped to minimize return flux distortion of the magnetic field symmetry in the coil. When operating the system with 1.5 MJ and crowbar - which had also been installed in the meantime - the copper sheets at certain places in the coil and extension region were hammered out of the feed slot. So we changed again the extension and coils for a solid steel version with welded copper contact bars which made possible the first 2.7 MJ crowbar shots.

In the 1964 and 1966 conferences the Isar I bank was described. So for more detailed information we refer to the corresponding reports [1 - 4].

Isar I is a 2.7 MJ 40 kV capacitor bank with a collector for one turn theta pinch coils of 1.5 to 5.4 meter length. The typical rise time of the discharge current is 10 μ sec; swinging and passive crowbar operation are possible. The maximum current is about 20 MA which corresponds to 170 kG in the 1.5 m coil and 47 kG in the 5.4 m coil. Picture P 20 shows a view on Isar I as it was put into operation in 1965.

The first coil version (see picture P 169) was a vertically divided 1.5 m long solid electrolytic copper coil, which operated satisfactorily at 30 kV (1.5 MJ) ringing discharges. The return flux distortion of magnetic field symmetry in the coil - created by the adjacent metal surfaces - caused plasma drift of about 25 mm towards the feed slot, which called for countermeasures.

A collector extension 90 cm long and 1.5 m wide was added. Picture P 175 shows the extension system with glass fibre reinforced epoxy resin bonded baryte blocks bolted together at 600 t total force. In between the blocks lay the extension steel plates with copper sheets for current conduction. The new steel coils were shaped for diminishing the return flux distortion of magnetic coil field. At two points of the coil and extension plate system (see picture P 170) the plate portions were not pressed together, that is at the feed slot of the coil (A) and at the interleaved insulation overlap region (B). Now in these regions after some 100 shots at 30 kV including 70 crowbarred the copper layers were hammered out the side slots. Inspection gave the result that only in these regions mentioned - not even in the coil - this shock effect occurred over the total width of the extension.

Consequently it was no edge effect due to field density distribution, on the other hand the local mechanical stress must have been twice or more compared to the theoretical magnetic field pressure. We think that the effect was due to shock stress of moving copper plate portion, combined with a local shock pressure overswing due to distribution of mechanical shock waves in the steel structure. We did not yet go through a quantitative analysis of the phenomenon. The extension plates and the coils were replaced by a solid steel version with welded copper contact zones (picture P 171). The spring layers between the baryte blocks and the steel structure - consisting of Mylar foil - were optimized with respect to minimum mechanical stress of the blocks (about 900 kp/cm^2) and minimum movement of the steel plates (about 0.4 mm theoretically) at the same time. The present coils (see picture P 169) have been worked from forged steel blocks, the feed slot was electro-eroded. The distance between coil axis and contact line has been increased in order to diminish the current density at the outer contact regions especially with mirror coils. The mirror coils (mirror 1:2) consist of a copper chrome alloy with a tensile strength of $35 \frac{\text{kp}}{\text{mm}^2}$ and 80 % copper-conductivity. The reason for choosing this alloy was the combination of these two values. According to the high conductivity the temperature rise in the mirror zone will be about 400° C at about 300 kG compared to a much higher value with steel. The extension region has been insulated with Mylar and outer sheets of Kapton (Dupont).

A 5.4 m coil has been prepared recently. (Picture P 172). The diameter has been increased so that the coil inductance is the same as with the 1.5 m coil. Because of the large vessel dimensions the coil was divided horizontally, the half shells consist of AlMgSi 0.5, a hardenable aluminium alloy with 50 % copper conductivity.

Our experience with the collector system looks like this: Up to now about 4400 shots including partial energy swinging and crowbared discharges at 0.5 - 2.7 MJ have been done. The precollectors in all their parts served without trouble. After about 3300 shots the main collector was dismantled because of a damage due to magnetic field pressure at low curvature radius and shock overstress due to different contours of copper and steel sheets. The following pictures show the damaged regions (picture P 173). They were discovered by occurring sparks before the main insulation was broken. After repair and assembling also the collector extension the hammering effect occurred and after about 3700 shots the extension had to be improved. Picture P 174 shows the hammered copper sheet at one of the coil sections. The new coil version has worked quite well at 2.7 MJ crowbared discharges, though we could not avoid some manufacture imperfections of the contact line copper welds.

References:

- 1 The 2.6 MJ Capacitor Bank at Garching A. Knobloch
Arrangement and Collector System
Report 4/12 1964 IPP Garching
- 2 New Fast Capacitor Banks for Theta- K.H. Fertl
Pinch-Experiments at the Institut für G. Herppich
Plasmaphysik in Garching A. Knobloch
Report 4/26 1966 IPP Garching H. Schlageter
- 3 Crowbar System at Isar I E. van Mark
Report 4/59 1968 IPP Garching H. Wedler
- 4 Inbetriebnahme einer 1.5 MWsec Stoß- A. Knobloch
stromanlage im Institut für Plasma- M. Ulrich
physik in Garching.
ETZB 1965 p. 136

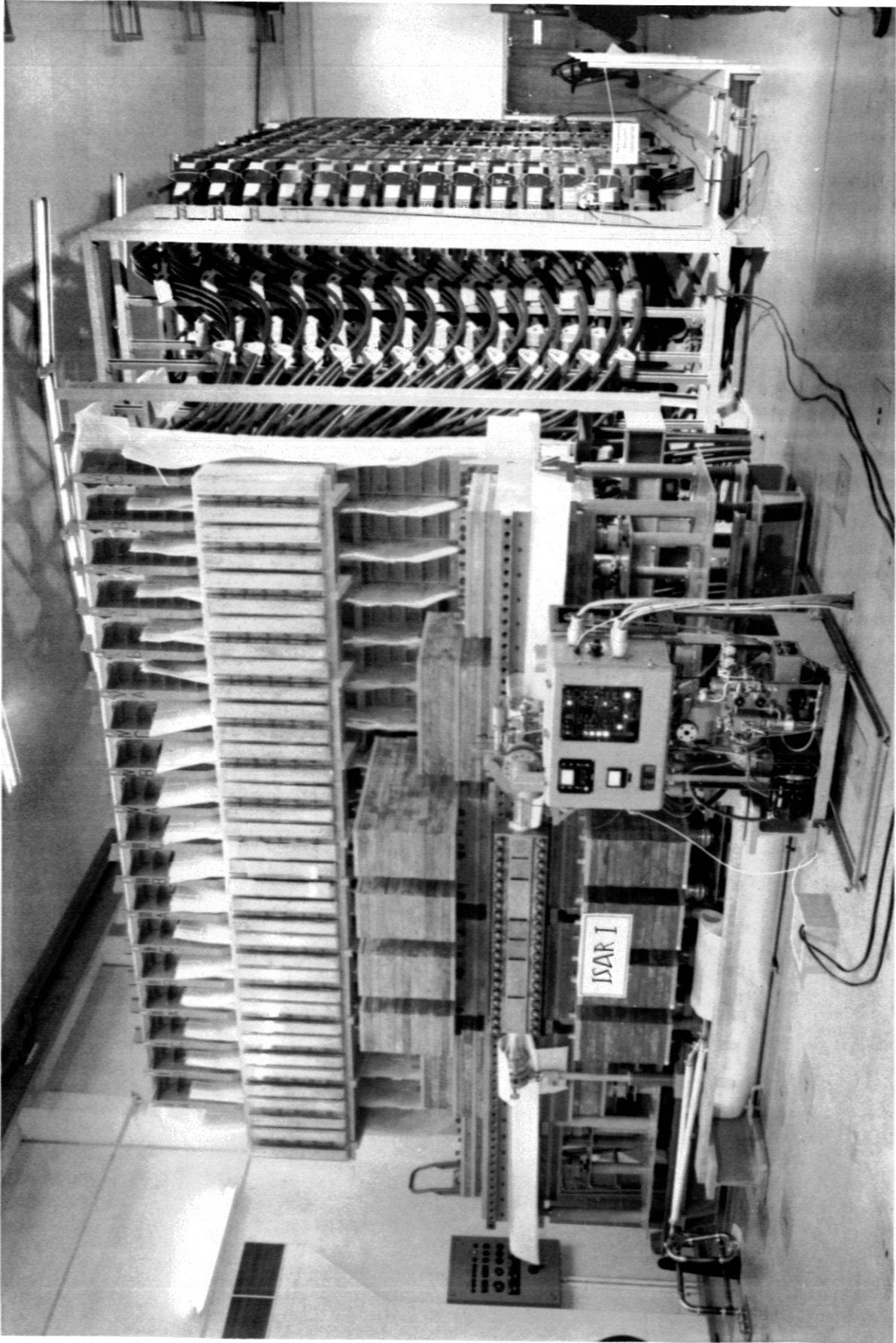

P 020 1,5/2,6 MJ - Theta-Pinch Isar I
Front view

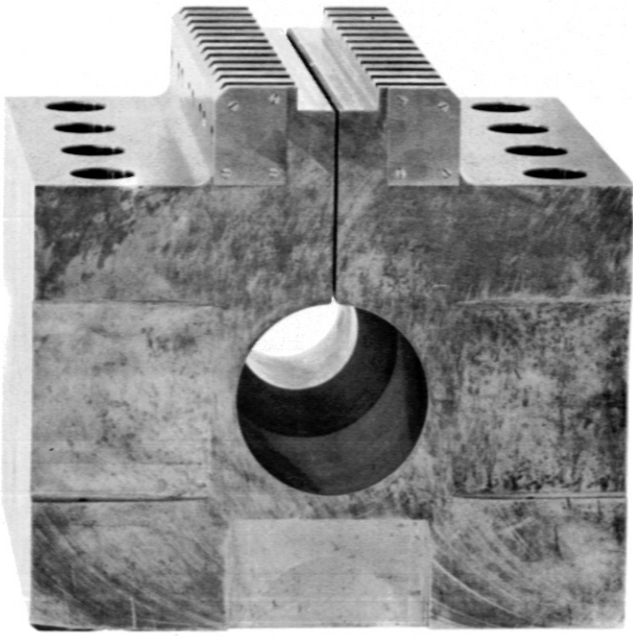

Type III (mirror)
CuCr

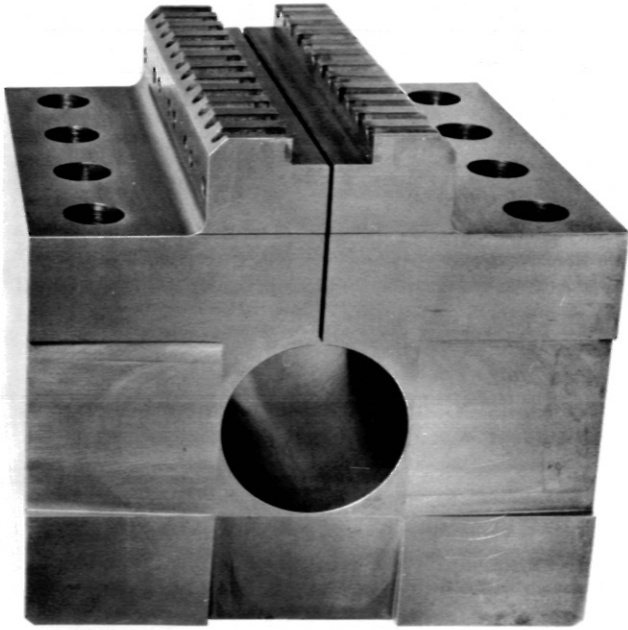

Type III
25CrMo4

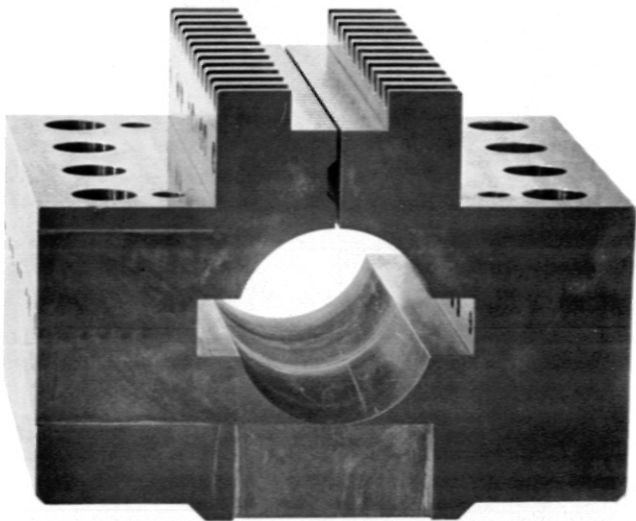

Type I
Cu

P 169 2,7 MJ - Bank Isar I
1,5 m coil sections

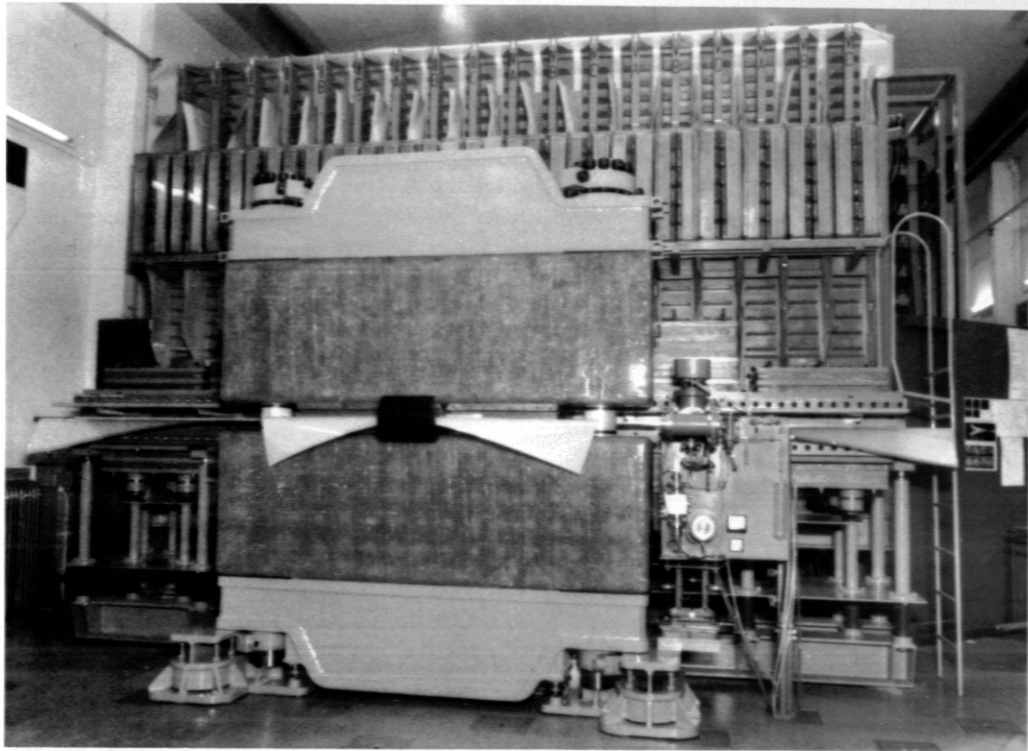

P 175 2,7 MJ - Bank Isar I
Collector extension (first version)

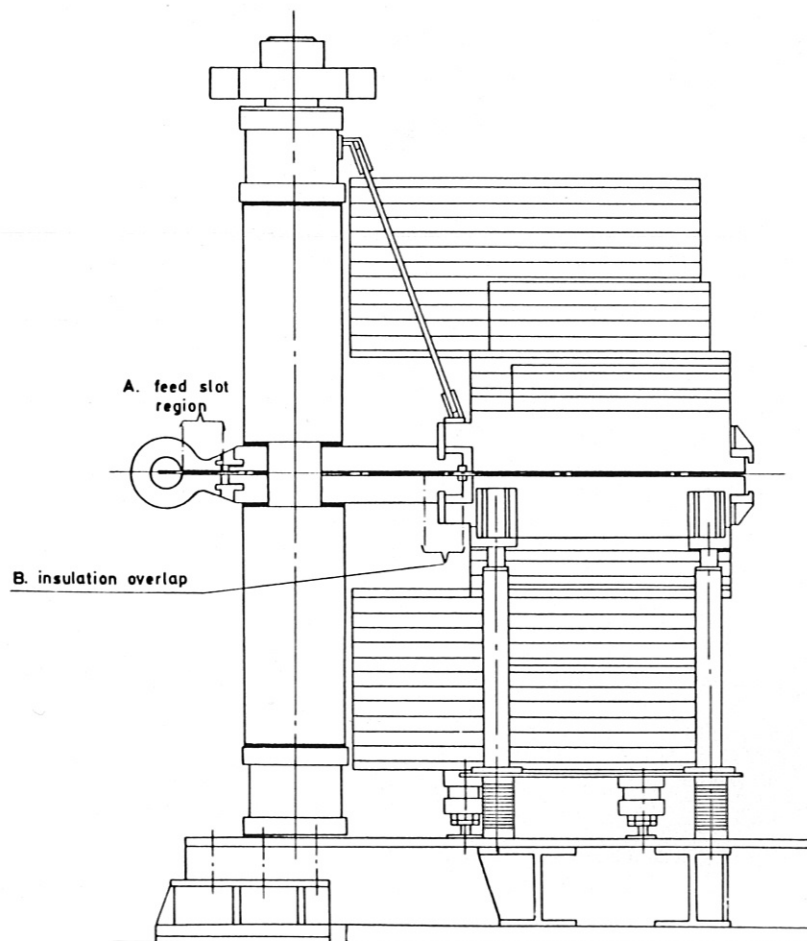

P 170 Collector Isar I
with extension (first version)

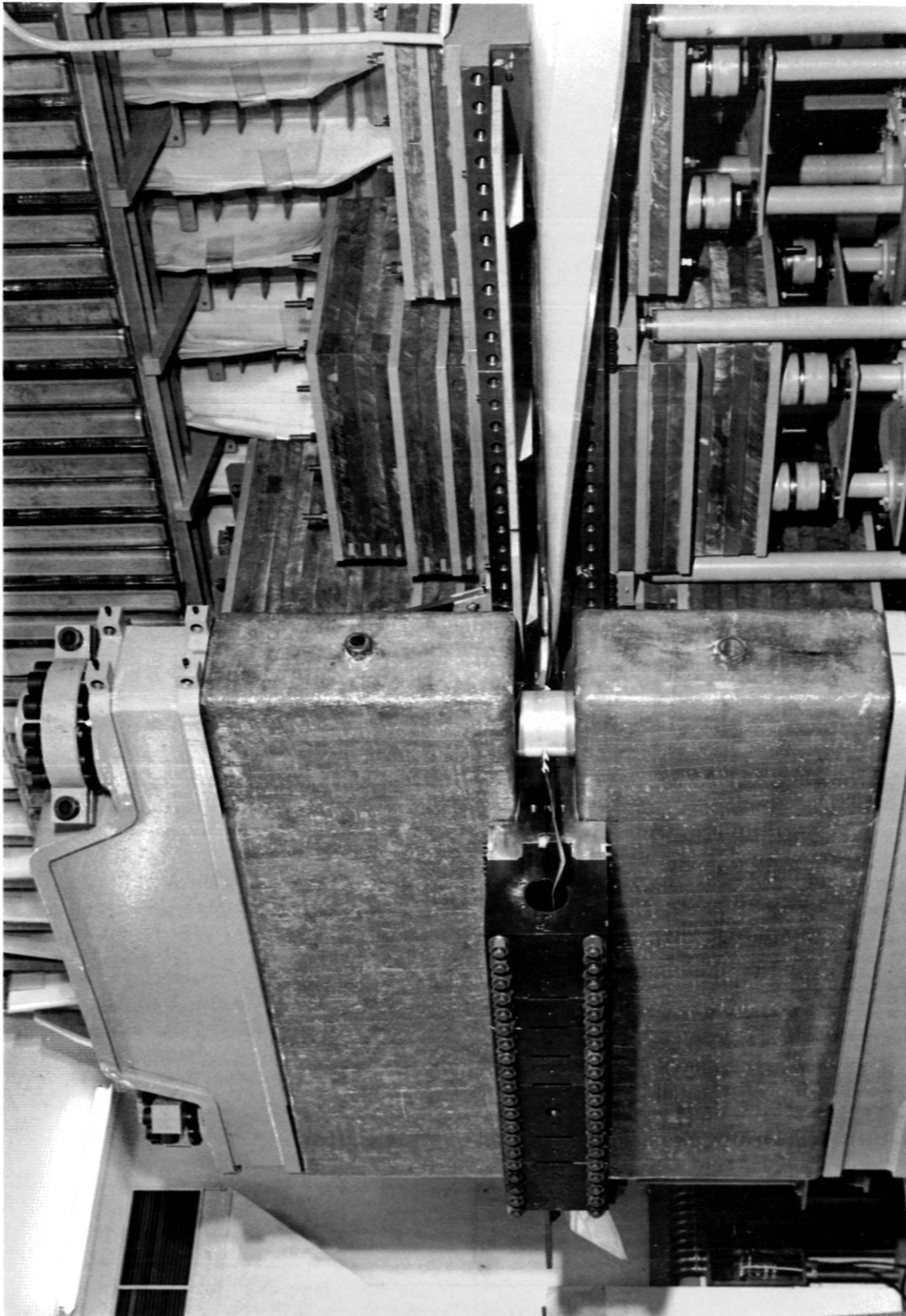

P 171 Collector Isar I
with extension (second version)

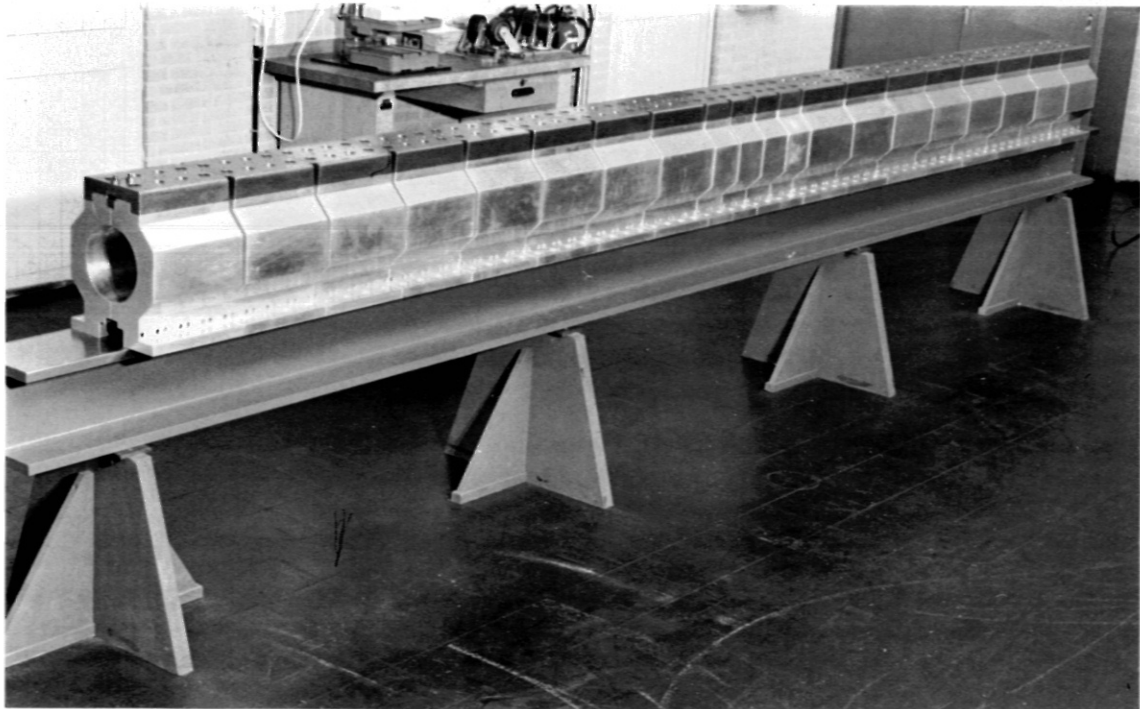
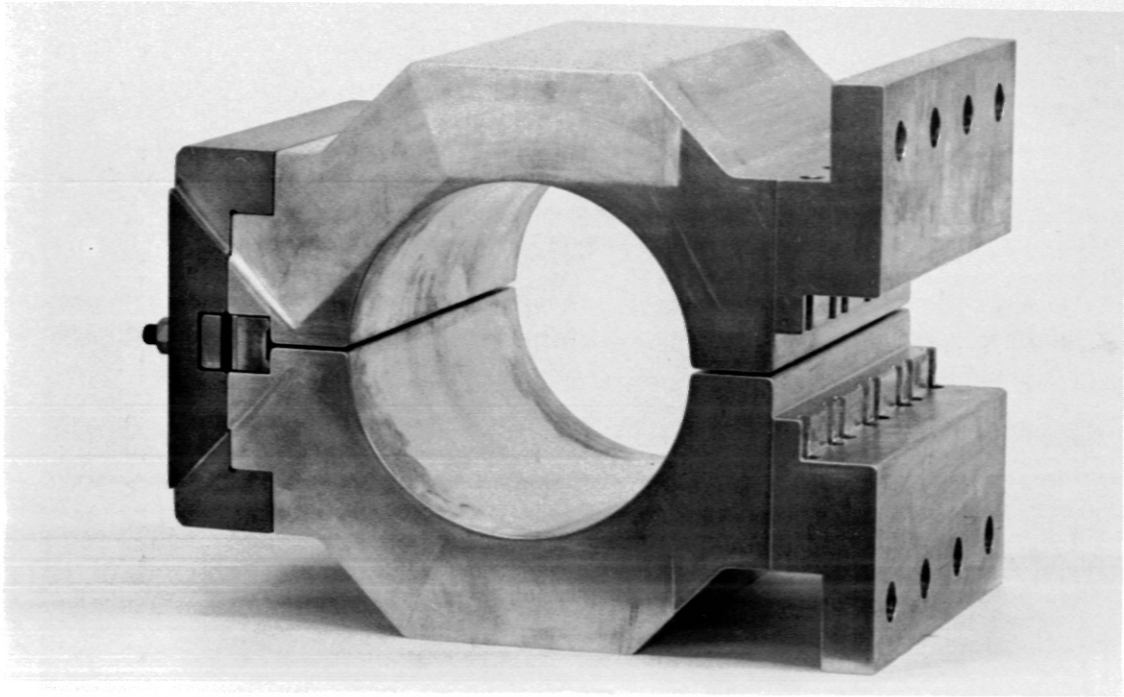

P 172 2,7 MJ - Bank Isar I
5,4 m - coil

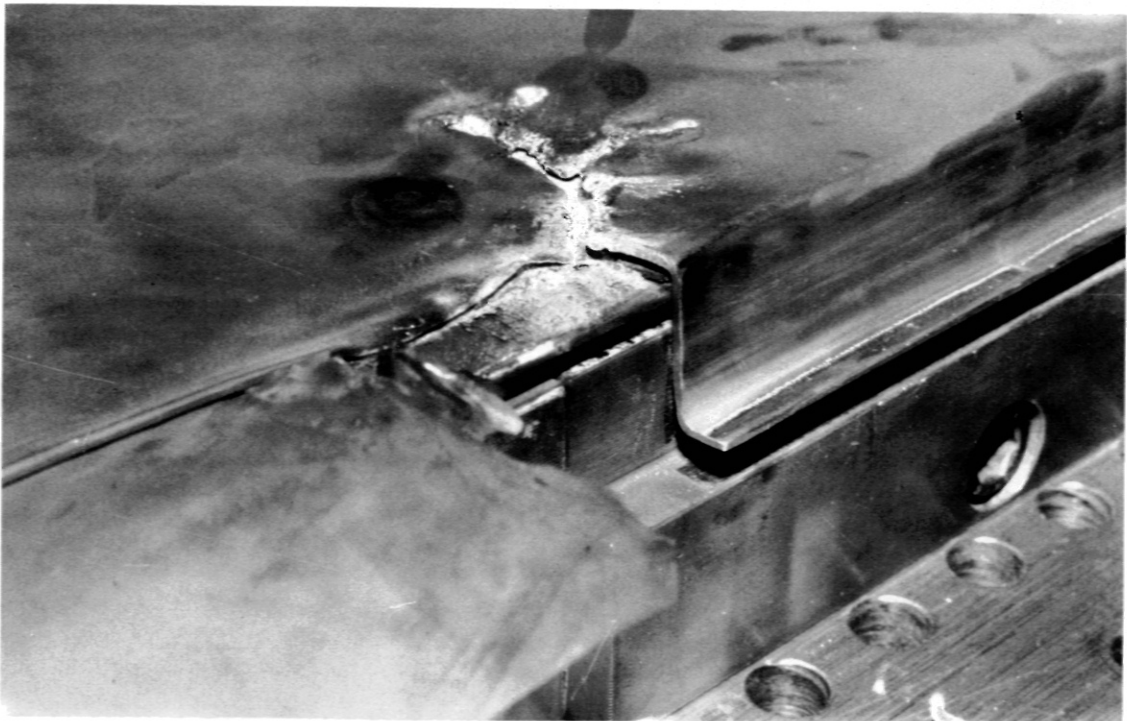
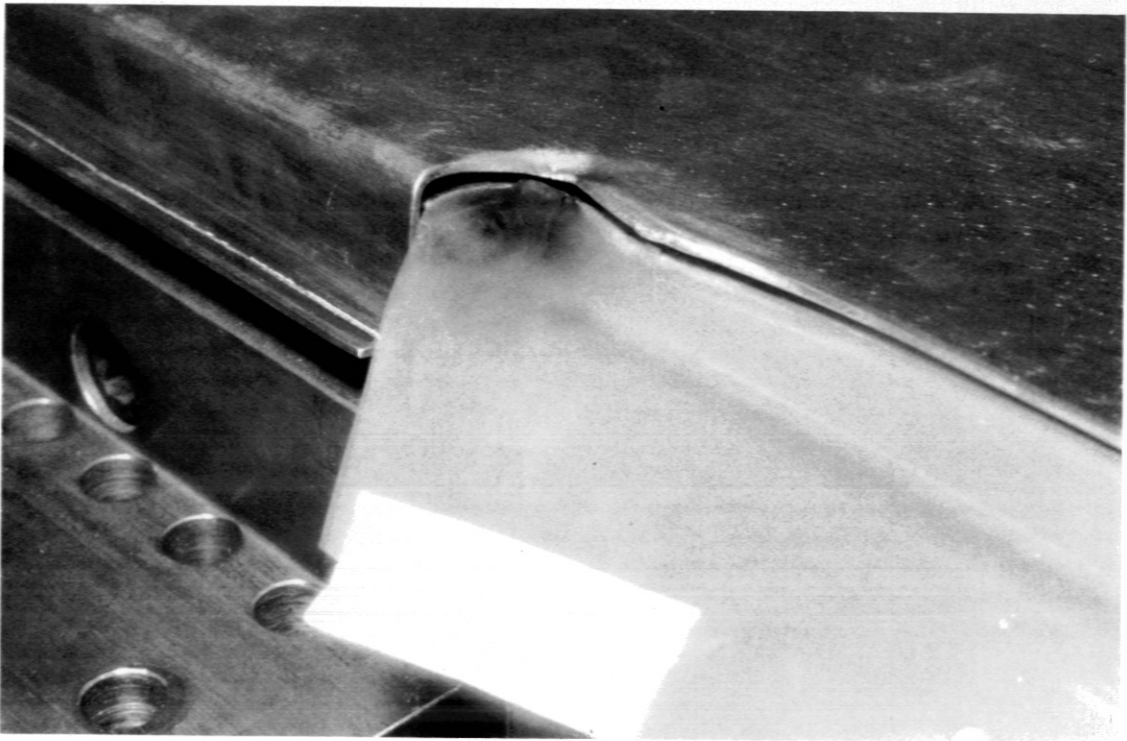

P 173 Collector Isar I

Hammering and sawing effect at main
collector copper plate (1,5 m - coil)

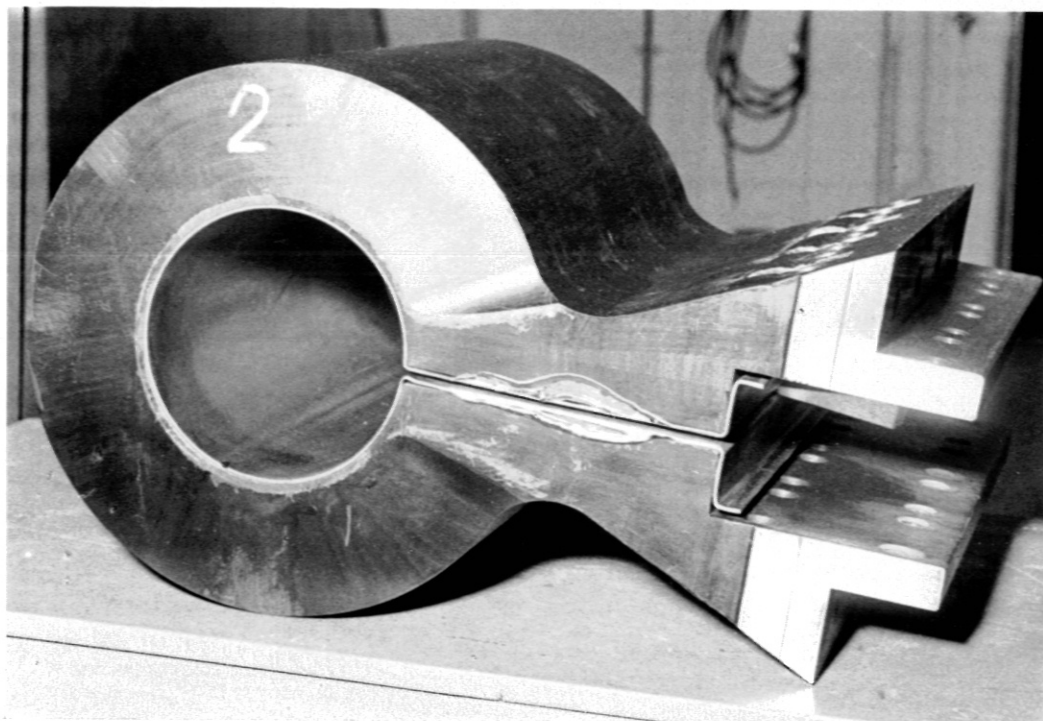
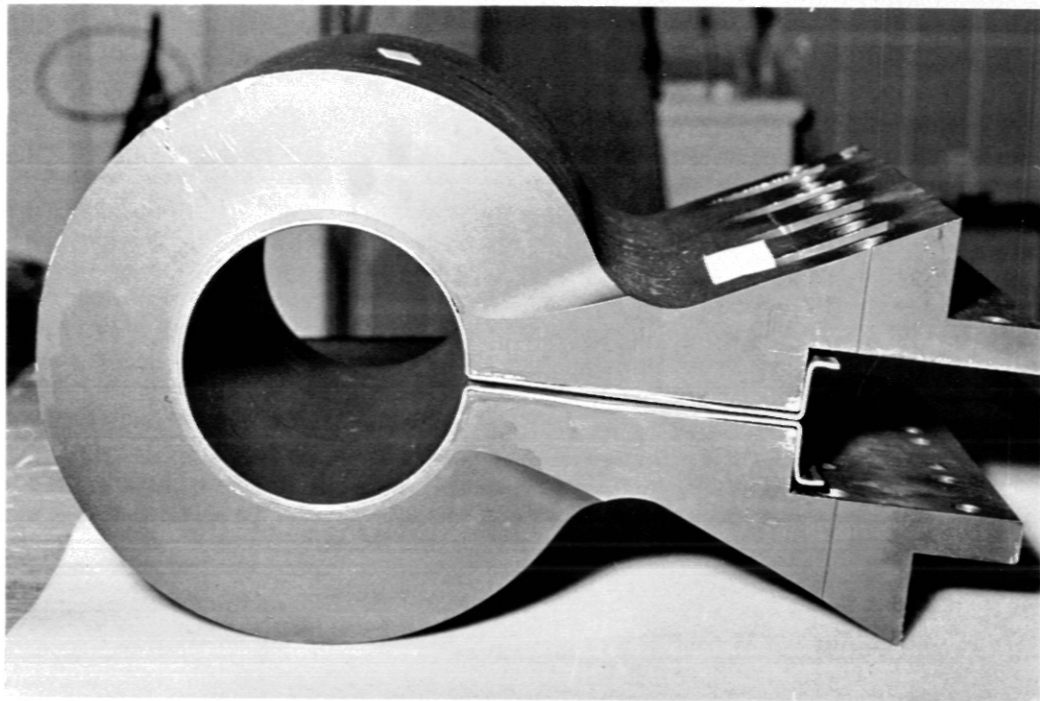

P 174 Collector Isar I

Hammering effect in the feed slot of
one coil section (1,5 m - coil, type II)