

Transient Voltage Decoupling Elements

(J.E. Gruber)

ABSTRACT

Transient voltage transients which enter trigger-circuits may cause errors or unexact timing in Thyatron generators.

IPP/4/37

April 1966

Elements such as spark gaps are used in the output line of the generator. Two types of spark gaps have been investigated with respect

I N S T I T U T F Ü R P L A S M A P H Y S I K

G A R C H I N G B E I M Ü N C H E N

INSTITUT FÜR PLASMAPHYSIK

GARCHING BEI MÜNCHEN

IPP 4/37 J.E. Gruber

Transient Voltage Decoupling
Elements

April, 1966

Transient Voltage Decoupling Elements

(J.E. Gruber)

ABSTRACT

Voltage transients which enter trigger-circuits may cause prematures or unexact timing in Thyatron generators.

Decoupling elements such as spark gaps can prevent these effects, if connected in the output line of the generator. Different types of spark gaps have been investigated with respect to their pulse breakdown voltage and jitter.

A very simple construction of a two electrode gap, with corona illumination gave lowest jitter of only ± 0.5 nsec. some of commercial available protective spark gaps also show appreciable low jitter.

Both types can be used in decoupling of voltage transients.

The contents of this report will be presented at the 4th Symposium on Engineering Problems in Thermonuclear Research, Frascati - Rome, 23 - 27 May 1966

Die nachstehende Arbeit wurde im Rahmen des Vertrages zwischen dem Institut für Plasmaphysik GmbH und der Europäischen Atomgemeinschaft über die Zusammenarbeit auf dem Gebiete der Plasmaphysik durchgeführt.

April, 1966

CONTENTS:

ABSTRACT

Abstract
Voltage transients which enter trigger-circuits may cause prematures or unexact timing in Thyatron generators.

Decoupling elements such as spark gaps can prevent these effects, if connected in the output line of the generator. Different types of spark gaps have been investigated with respect to their pulse breakdown voltage and jitter. to voltage

transients.
A very simple construction of a two electrode gap, with corona illumination gave lowest jitter of only ± 0.5 nsec. some of commercial available protective spark gaps also show appreciable low jitter. The experimental arrangement.

Both types can be used in decoupling of voltage transients.

pulse of a HV-Thyatron generator.

6. Conclusions.
7. Acknowledgements.
8. References.
9. Figures.

1. INTRODUCTION

Most capacitor banks for production of fast current pulses are operated at voltages ranging from several kV up to 100kV and more. Switches such as spark gaps, ignitrons or others currently used in capacitor banks require pulses of high voltage or high current to get triggered. The high voltage Thyatron - Pulse - generator has proved to be the most useful instrument to supply HV-Pulses with low time jitter for trigger purposes. In most applications the trigger pulses have to be of short rise time and of values which are in the same magnitude as bank voltages or higher, to give short breakdown times with respect to the switches. In consequence the Thyatron tubes are run very near their peak permissible voltage, which is about 15% for the present stage of development (Thyatron tubes for 50kV or 40kV (Deuterium filled, ceramic envelope) are already commercially available).

CONTENTS:

Abstract

1. Introduction
2. The Thyatron pulse generator and effects of voltage transients.
3. Methods preventing effects due to voltage transients.
 - 3.1 Decoupling elements.
4. The experimental arrangement.
5. The effect of the decoupling element on the output pulse of a HV-Thyatron generator.
6. Conclusions.
7. Acknowledgements.
8. References.
9. Figures.

The main effort of this investigation was to find a proper and simple solution towards the unwanted effects. Only discussion of the HV side of the Thyatron generator is given here, though voltage transients which enter the low voltage stage (input stage) of a pulse generator may give similar or even more serious troubles. Methods of shielding, use of appropriate bias voltages and isolating transformer inputs are well known and common in use.

Decoupling devices such as isolating spark gaps have found to be simple and reliable elements to keep off HV - transients entering the thyatron generator through the output line. After a short discussion of the commonly used HV - Thyatron-circuit, experimental measurements of the influence of transient voltages on its switching characteristics are given.

1. INTRODUCTION

Most capacitor banks for production of fast current pulses are operated at voltages ranging from several kV up to 100kV and more. Switches such as spark gaps, ignitrons or others currently used in capacitor banks require pulses of high voltage or high current to get triggered. The high voltage Thyatron - Pulse - generator has proved to be a most useful instrument to supply HV-Pulses with low time jitter for trigger purposes. In most applications the trigger pulses have to be of a short rise time and of values which are in the same magnitude as bank voltages or higher, to give short breakdown times with low jitter in the switches. In consequence the Thyatron tubes are run very near their peak permissible voltage, which is about 15kV for the most used Hydrogen Thyatron Tubes (5C22, PL522). It should be noticed that at the present stage of development Thyatron tubes for 25kV or 40kV (Deuterium filled, ceramic envelope) are already commercially available but excessive price still prevent a general use of these tubes for trigger pulse generators.

The problem to be discussed here does occur in many experiments in thermonuclear research when different capacitor banks are integrated into one experiment. Very often the capacitor banks, operated at the higher voltages, have to be fired first (e.g. preionization circuits) and even with careful selection of earth lines and appropriate arrangements of circuit elements, voltage transients are generated either by pick up or inducing. These start to travel along in pulse lines, trigger lines or even constructional metal frame work. Transients may enter trigger-circuits of those capacitor banks to be fired at a delayed time and cause there prematures or fault-timing of the trigger-pulse-generators.

The main effort of this investigation was to find a proper and simple solution towards the unwanted effects. Only discussion of the HV side of the thyatron generator is given here, though voltage transients which enter the low voltage stage (input stage) of a pulse generator may give similar or even more serious troubles. Methods of shielding, use of appropriate bias voltages and isolating transformer inputs are well known and common in use.

Decoupling devices such as isolating spark gaps have found to be simple and reliable elements to keep off HV - transients entering the thyatron generator through the output line. After a short discussion of the commonly used HV - Thyatron-circuit, experimental measurements of the influence of transient voltages on its switching characteristics are given.

2. THE THYRATRON-PULSE-GENERATOR AND EFFECTS OF VOLTAGE TRANSIENTS.

In Fig. 1 a typical spark-gap trigger circuit as it is common in use(1) is shown. The pulse-generating part of it is a HV-Thyratron stage in which a charged pulse forming network, which may be a condenser in its simplest form, is discharged by the Thyratron into the trigger line. The HV-Thyratron will switch after a positive pulse has been supplied to its grid. This starting pulse will come either from an integrated low voltage amplifier stage or a separate pulse unit. It is known that there is a certain relation between the value of the positive grid pulse and the anode delay time and for best performance this starting pulse should have a peak value of 200V or more, with a steep front rise of only a few msec.

The problem encountered here is that, despite good shielding and remote position operation of the pulse-generator, voltage transients still may enter the trigger circuit through the output pulse line i.e. the trigger cable on the HV-side.

If a positive going pulse lifts the potential of the output point A by a value $+V_T$ then the anode point B will see a potential $(V_0 + V_T)$ and depending on the value V_T and the wave shape, prefire of the Thyratron tube will occur.

To obtain a quantitative information on the failure causing values of transients, a pulse generating circuit has been connected to the end of a standard thyratron pulse generator.

In Fig. 2 critical values of voltage transients which cause premature are shown in dependence of thyratron anode voltage. A single pulse (curve d) or a highly damped oscillatory pulse (curve a) of about 12kV peak cause prefire, and there is a clear indication that transients of higher frequencies (curve c) and also of lower damping factors (curve b) will cause prematures at lower voltages. Also if the output parallel resistor R_2 is increased from 50 Ω to 2k Ω a further remarkable reduction of the critical voltage will follow.

The exact triggering time of switches in capacitor banks becomes more and more important, with the use of capacitor banks with shorter rise times and more compact arrangement of bank elements. It can be expected that in the presence of voltage transients, the anode-delay time of the thyratron will be altered and therefore additional jitter is introduced in the trigger circuit. Fig. 3 shows the change of the anode delay time versus anode voltage. As this measurement has been carried out with D.C. - Voltage it will give only an indication to which amount the anode delay time will be changed by transient voltages.

(d) Isolating Gaps: The main effort of this investigation has been given to elements of a "Spark-gap" type.

3. METHODS PREVENTING EFFECTS DUE TO VOLTAGE TRANSIENTS.

It is obvious that any kind of voltage transient should be prevented to enter the HV circuit of a thyatron generator to avoid the previous discussed effects of premature or unexact timing.

The use of a decoupling device in the output line of the Thyatron Circuit will become necessary for all generators installed in condenser bank systems. The requirements for such an element can be summarised:-

- (a) The element should either "keep off" or "attenuate" to a safe low level all in running voltage transients of any polarity.
- (b) The voltage pulse generated from the HV-Thyatron stage has to pass the decoupling element without attenuation of its peak value or slowing down its front rise. The latter condition means that the frequency response has to be in the order of 100 MCs or more.

3.1 Decoupling Elements

Decoupling can be done in different ways:

- (a) Impulse transformer: The influence of a voltage transient is reduced only by its transformation ratio. As can be deduced from the Diagram in Fig. 2, this will give only protection against certain low frequency components of a transient wave and is therefore only a part-solution of the problem.
- (b) Filters seem to have no chance as most transients are composed of harmonics up to frequencies of 100 MC and more, and effective attenuation of these will attenuate the output pulse as well.
- (c) Diodes: Up to date single elements with a peak inverse voltage of 3 kV are commercially available and therefore series arrangements would be necessary for higher voltages. Though application of diodes in 15 kV pulse generators does not seem to be useful, they may be used quite satisfactorily in pulse-generators for triggering ignitrons which normally work in the range from 1.5 kV to 5 kV.

(d) Isolating Gaps: The main effort of this investigation has been given to elements of a "Spark-gap" type construction. A two electrode spark gap arranged in the output line of the pulse generator will keep off all voltage transients whose pulse height are lower than the pulse breakdown voltage of the element. This breakdown voltage has to be chosen so that the trigger pulse of the generator which in our case is a 15 kV pulse, will fire the decoupling gap. From the viewpoint of prematures the pulse breakdown voltage (V_{BP}) of the element should be as high as possible, i.e. it should be near the pulse generator voltage. But in practice it has been found sufficient in many applications, if V_{BP} is of the order of several kV. The jitter of the overall system will be determined by the jitter of the components of the generator: the preamplifier, the thyatron and the decoupling gap. But the influence of the latter on the output waveshape will depend on the time point where the decoupling gap closes. If the gap closes very soon after the thyatron has fired then the additional jitter of the gap determines only the shape of the first rising part of the output pulse. Under "jitter" we have to understand here the time variation of the output pulse if the whole pulse generator is considered, or in the case of the thyatron and the decoupling gap, the time variation of the start of anode voltage collapse, respective gap voltage collapse.

Usually the jitter of preamplifier and thyatron stage together is about 2 to 5 nanosec and this value should not be increased by insertion of a decoupling element, in other words the jitter of the latter has to be less than one nanosec.

Different spark gaps have been investigated with respect to their pulse breakdown voltage and their jitter.

The selection of a suitable decoupling gap was carried out by looking for either a

- simple air gap construction

or

- a sealed off device.

The jitter of an over-volted gap is determined mainly by the statistical time lag which can be described as "waiting for a free electron" in the interspace between the two electrodes of a gap. Fletcher⁽²⁾ and also Hancox and Goodall⁽³⁾ showed that by strong UV-irradiation of the cathode the statistical time lag could be eliminated. DC supply of positive polarity in order to obtain a steady corona discharge. A corona current of 2 μ A was found to give sufficient ionization in the gap without establishing a visible discharge channel.

The common method in HV-switching techniques for supply of UV-irradiation, is to ignite an auxiliary gap nearby the main gap. This method was thought to be too complicated for a decoupling gap, as it would involve having a very small auxiliary gap (only a fraction of mm). Other ways seemed to offer less difficulties and therefore have been followed.

Using the effect of "field emission" does suggest a non-uniform gap geometry and consequently gaps of point-plane, sphere-sphere, and sphere-plane geometry have been investigated. Measurements of Meek⁽⁴⁾ in 1.1 mm gaps show a superiority of a point-sphere gap over a sphere-sphere gap, and also finds that some materials with lower work functions give considerably lower statistical time lags than others, but these measurements had been carried out at relatively small over-voltages from 150% down to 20%.

With a point-plane gap built up from a flat electrode with rounded edges (diameter 25.4 mm, edges $r = 2$ mm, copper) and a point electrode (0.1 mm point, stainless steel) as shown in Fig. 4. Measurements of the pulse breakdown voltage and jitter, Fig. 5, show no significant advantage compared to a sphere-plane geometry (sphere 6.3 mm ϕ , stainless steel) for a gap distance of 0.5 mm.

Similar values were obtained with a 2 mm sphere-sphere gap. The lowest jitter was found for the point-plane gap being ± 4 nsec, and the highest value was observed for the sphere-sphere gap with ± 16 nsec. This was expected but the value for the point-plane geometry was though to be unsatisfactory still.

Another method for lowering the statistical time lag is to establish a corona discharge in the neighbourhood of the main gap. This method has been known for years⁽⁵⁾, and was used to give better consistency of impulse breakdown voltage measurement in a sphere-sphere gap arrangement.

Consequently a decoupling gap using this method has been built, the components can be seen in Fig. 6.

Two stainless steel electrodes of spherical shape, each 6.5 mm in diameter, are screwed into a perspex cylinder. This allows setting of gap distance up to several mm.

A symmetrical to both sphere-electrodes arranged corona electrode (tungsten 1 mm rod, ground conically to a 0.01 mm point) gives corona illumination of the gap and the electrode surfaces. The corona electrode has to be connected to a DC supply of positive polarity in order to obtain a steady corona discharge. A corona current of 2 μ A was found to give sufficient ionization in the gap without establishing a visible discharge channel.

This current was obtained when the corona electrode was connected through a 500 Megohm resistor to a 6 kV DC supply.

The location of the electrode is not very critical as long as it is not placed too close to the main electrodes, which would cause the main discharge channel to be drawn to the corona point and this of course would spoil the sharp spike of the corona electrode within a few discharges only.

In the Diagram Fig. 7, which shows the breakdown voltage of the new gap arrangement with corona electrode, a significant improvement of jitter can be seen. Without corona illumination in a 1 mm gap a jitter of + 6 nsec has been measured and after supply of corona a final jitter of only + 0.5 nsec was observed. This value was more or less constant over a range of gap settings varying from 0.5 to 2 mm, and this will cover a range in breakdown voltage from 5.6 kV to 14 kV.

In Fig. 8 the curves for static and pulse breakdown with corona illumination have been plotted, and for illustration the values obtained with the same gap without corona are given.

4. THE EFFECT OF THE CHOICE OF ELECTRODE MATERIAL ON THE OUTPUT PULSE
Considering the choice of electrode material it can be expected that under the given discharge conditions, i.e. the discharge of a comparatively small capacity in the pulse generator into a trigger cable which will give less than 1 kA, no serious problems with erosion should occur. Meek et al.⁽⁴⁾ reported on the dependence of the statistical time lag for different materials and found for Iron and Aluminium smaller time lags than for copper, and has this contributed to the different work function. Van der Laan et al.⁽⁶⁾ found in an erosion test that brass, stainless steel and aluminium were superior to others in spite of higher erosion, because of a better consistency in the surface smoothness.

The choice for the decoupling gap has been given therefore to stainless steel, also with respect to the intermittent use of pulse generators which would favour the generation of oxide layers on other materials.

5. THE EFFECT OF THE DECOUPLING ELEMENT ON THE OUTPUT PULSE
In addition some of the commercially available protective spark gaps, used in low voltage equipment for protection against lightning over-voltages, have been investigated and measurements show very low jitter for some types, similar to the value obtained for the corona gap. In table 1 all investigated elements have been listed together with the measured values of breakdown voltages and jitter. The measurements of protective spark gaps show considerable spread depending upon types of different voltages and manufacturers. Best values have been obtained for Siemens elements designed for a DC-breakdown voltage of 1400 Volts and currents up to several kA. The jitter in pulse breakdown

voltage of this element has been found to be less than 1 nsec as shown in Fig. 9. This element therefore would also be applicable in cases where a lower pulse breakdown voltage is desirable. The listed values in Table 1 for the protective gaps are mean values, of 5 (resp. 2) probes.

Finally, a lifetest has been carried out with these elements which had a satisfactory low jitter, i.e. with the corona spark gap and the protective spark gap ES Sich 36/1400. The elements had to pass a pulse of the same amount as they will obtain when used in a 15 kV pulse generator. After 10,000 pulses passed through a corona gap of the type previously discussed, measurement of the pulse breakdown voltage showed no measurable change and also jitter remained as low as at the start. A similar result was obtained for the protective gaps ES Sich 36/1400. After 40,000 pulses 5 probes showed an increase in pulse breakdown voltage of less than 10% and the jitter remained uneffectively small.

7. ACKNOWLEDGMENTS

4. THE EXPERIMENTAL ARRANGEMENT

4.1 D.C.-breakdown voltage. The measurement of DC-breakdown voltage was carried out with a circuit as shown in Fig. 10a. All listed values in Table 1 are mean values out of 5 readings of the static voltmeter.

4.2 Pulse Breakdown voltage (Fig. 10b). A pulse out of a thyatron generator was supplied via a 50 Ω coaxial cable either direct to the gap under investigation, or, for those elements which had small values of breakdown voltage (e.g. Fig. 9), was divided down by resistors to a suitable value. Observation of the gap voltage was done by means of fast oscilloscopes Tektronix 519 or Tektronix 507 and resistive voltage dividers with nsec response.

5. THE EFFECT OF THE DECOUPLING ELEMENT ON THE OUTPUT PULSE OF THE HV-THYRATRON GENERATOR

As discussed previously one of the requirements of the decoupling elements is neither to attenuate the output pulse nor to raise the overall jitter of the system. Decoupling elements of both types, i.e. the corona gap type and the protective spark gap Siemens ES Sich/36/1400, have been built into a standard pulse generator in series with the output line as shown in Fig. 1. For the arrangement with the corona gap an internal resistive divider connected to the HV supply gave the required + 6 kV and the corona electrode was connected through a 500 M Ω resistor to this potential point.

8. REFERENCES

Oscillograms, Fig. 11, taken for both devices show that there is only a "steepening" effect on the output pulse with the decoupling elements built in. Fig. 12 shows the final layout with a corona gap built into a HV-pulse generator of usual construction.

at atmospheric pressure.
Phys. Review, Vol. 77, No. 10, 1949, pp. 1301

6. CONCLUSIONS

Decoupling of transients has been found to be necessary in the presence of voltage transients upwards from a few kV. By means of a corona type decoupling gap of simple construction, decoupling of transients is possible without changing the important small jitter of the thyatron generator. A similar solution was found with a protective spark gap commercially available, this element can be useful where only small voltage transients are awaited.

Laan, A. De Troop, Some Properties of a high current spark gap, Rep. EUR 1044.e, Euratom 1964.

7. ACKNOWLEDGEMENTS

This work was started in the Institut fur Plasmaphysik in Garching, Germany and finally completed in the Culham Laboratory, England. The author wishes to thank K. M. Schmitter (Garching) and D.L. Smart (Culham) as well as all colleagues in both institutes for their assistance.

9. FIGURES

- Fig. 6 Sphere-sphere gap assembly with corona electrode.
- Fig. 7 Pulse breakdown voltage in a sphere-sphere gap with corona electrode.
- Fig. 8 Breakdown voltage of decoupling gap, final arrangement.
- Fig. 9 Protective spark gap ES Sich 36/1000 pulse breakdown characteristic.
- Fig. 10 Measurement of D.C and pulse-breakdown voltage circuit diagram.
- Fig. 11 Thyatron generator output pulse, Effect of decoupling element.
- Fig. 12 View of Thyatron generator with decoupling gap in situ.

This work was performed under the terms of the agreement on association between the Institut für Plasmaphysik and EURATOM

8. REFERENCES

1. Lewis I.A.D., Wells F.H., Millimicrosecond pulse Techniques, Pergamon London 1959.
2. Fletcher R.C., Impulse Breakdown in the 10^{-9} sec range of air at atmospheric pressure. Phys. Review, Vol.76, No.10, 1949, pp.1501.
3. Goodall D.H.T, Hancock R, Formative time lags in a pressurised spark gap. IV Conf. Phen. d'ionisation dans Les gaz, Paris 1963, Vol.II. 337.
4. Meek T.M, Craggs T.D., Electrical Breakdown in Gases, Clarendon Press, Oxford, 1953, Chapt. VIII.
5. Wynn-Williams C.E., Phil. Mag. 1 (1926) pp.353.
6. Van der Laan, A.De Tong, Some Properties of a high current spark gap, Rep. EUR 1644.e, Euratom 1964.

9. FIGURES

- Fig. 1 High voltage thyatron pulse generator.
- Fig. 2 Critical voltage transients to cause premature of a Thyatron.
- Fig. 3 Change of anode delay time by varying anode voltage.
- Fig. 4 Point-Plane and Sphere-Plane Gap assembly.
- Fig. 5 Breakdown voltage and jitter.
- Fig. 6 Sphere-sphere gap assembly with corona electrode.
- Fig. 7 Pulse breakdown voltage in a sphere-sphere gap with corona electrode.
- Fig. 8 Breakdown voltage of decoupling gap, final arrangement.
- Fig. 9 Protective spark gap ES Sich 36/1400 pulse breakdown characteristic.
- Fig.10 Measurement of D.C and pulse-breakdown voltage circuit diagram.
- Fig.11 Thyatron generator output pulse, Effect of decoupling element.
- Fig.12 View of Thyatron generator with decoupling gap in situ.


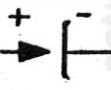
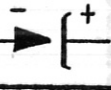
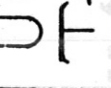

Description	\bar{V}_B DC kV	\bar{V}_B pulse kV	ΔV_B pulse \pm kV	Δt_B \pm nsec
Air gap  D = 20mm d = 0,25mm	3	4.6	1.4	16
Air gap  d = 0.5mm	2.65	28.5	16.2	5
Air gap  d = 0.5mm	2.2	17.1	12.3	4
Air gap  D = 6.5mm d = 0.5mm	3.4	32.2	10.5	7
Air gap  w.corona D = 6.5mm d = 0.5mm	3.2	4	0.3	0.5
Protective Gap, 5 Probes Siemens, ES/Sich 36/600V	0.56	2.6	0.31	3.3
Protective Gap, 5 Probes Siemens, ES/Sich 36/1400V	1.18	4.1	0.12	< 1
Protective Gap, 5 Probes Wickmann, PL13797/230V	0.23	1.54	0.56	4
Protective Gap, 2 Probes Wickmann, PL13818/1kV	1.03	9.75	4	110

Table 1 Decoupling Elements

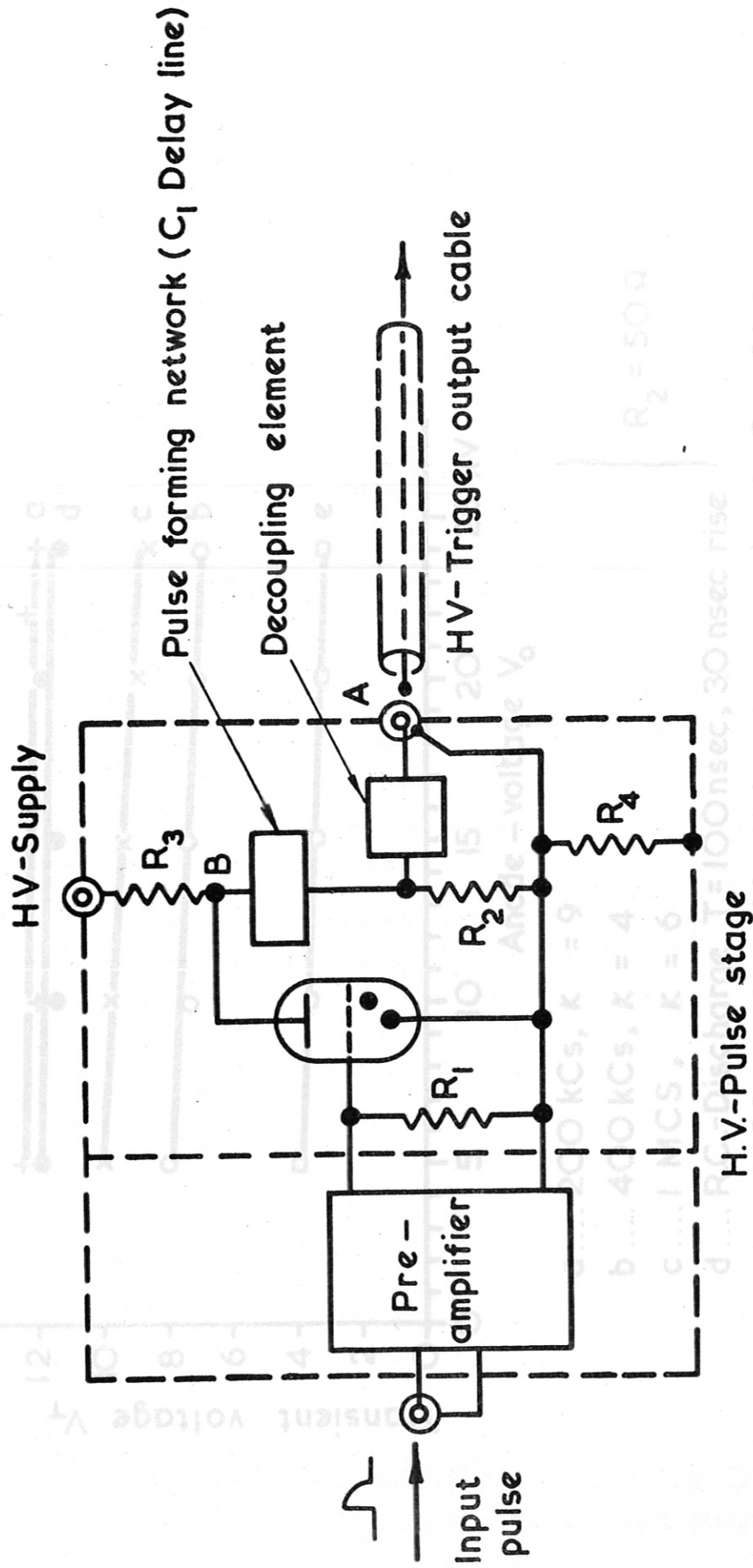


Figure 1 High voltage Thyatron pulse generator

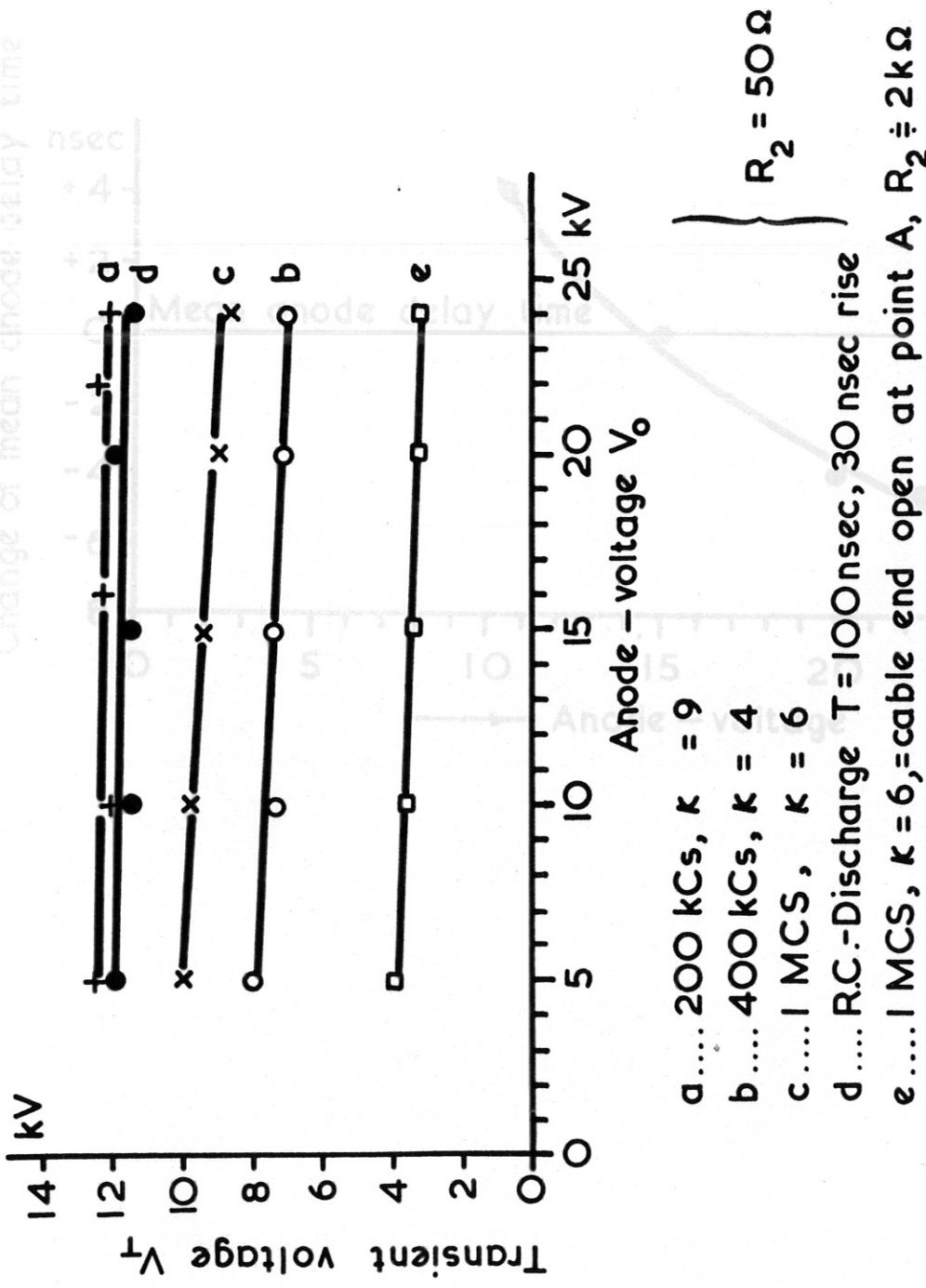


Figure 2 Critical voltage transients to cause premature of a Thyatron (5C22)

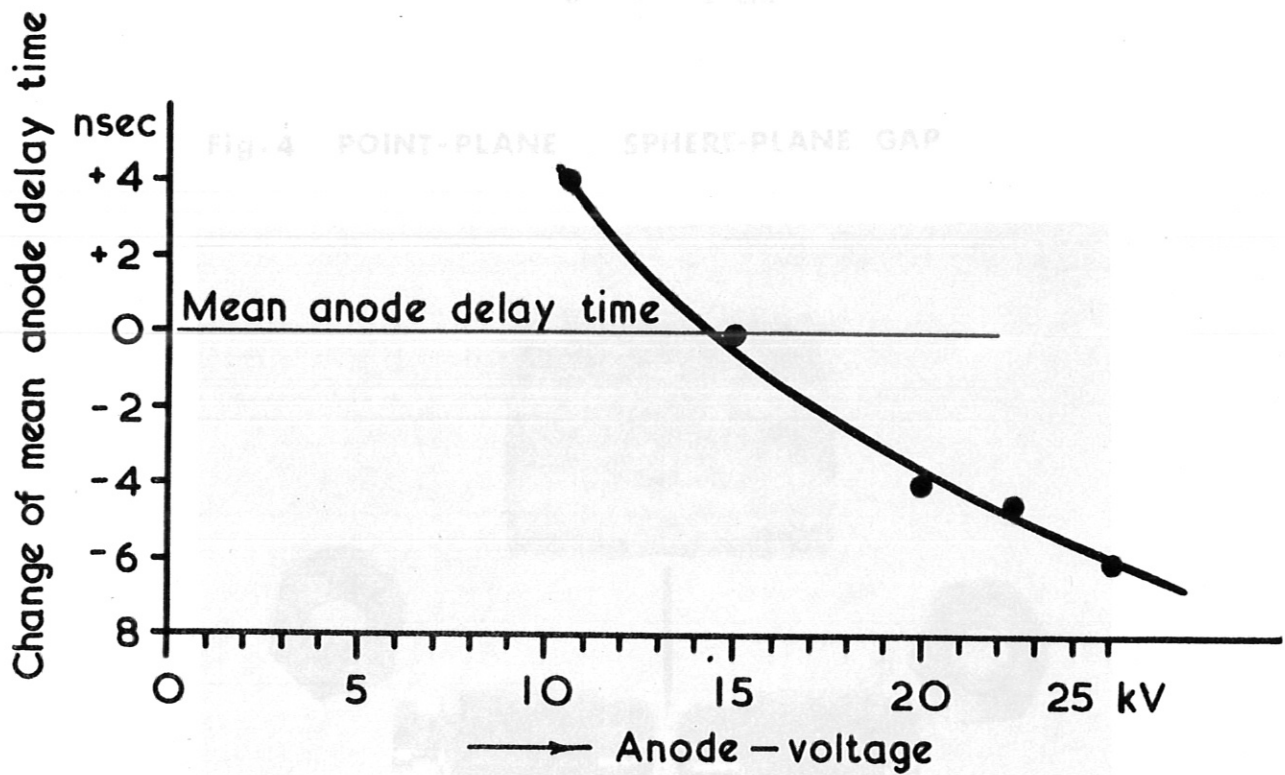


FIG-6 SPHERE-SPHERE GAP with CORONA ELEKTRODE

Figure 3 Change of anode delay time by varying anode voltage

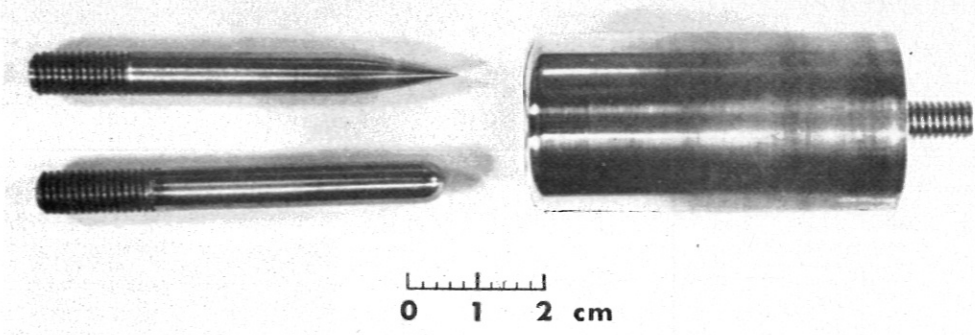


Fig.4 POINT-PLANE SPHERE-PLANE GAP

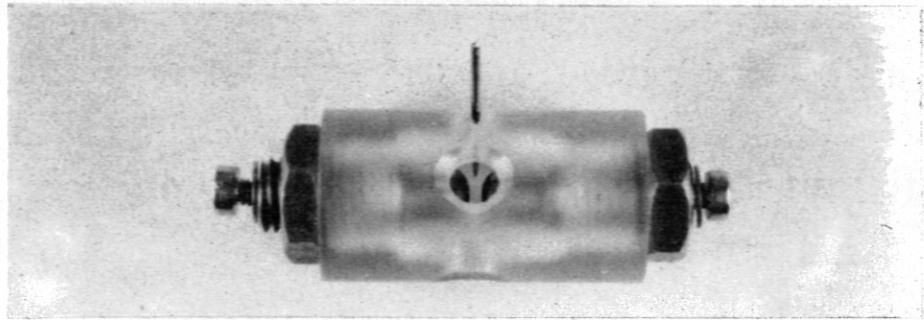
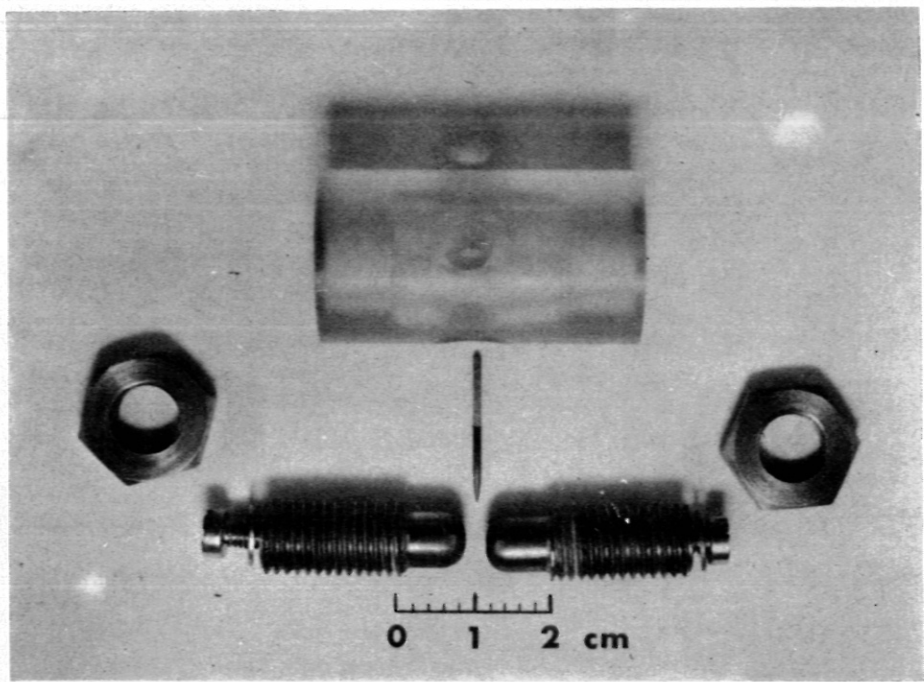


FIG.6 SPHERE-SPHERE GAP with CORONA ELEKTRODE

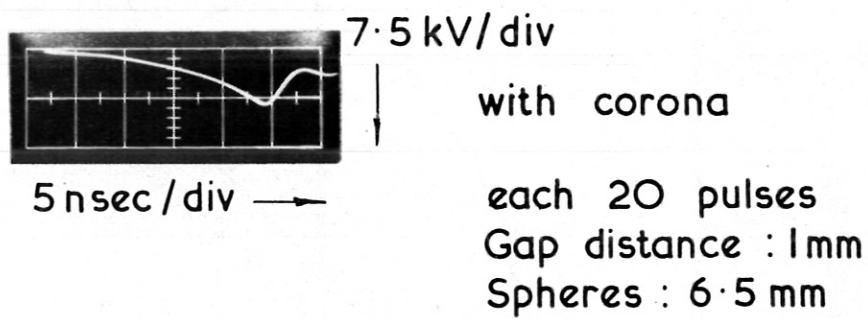
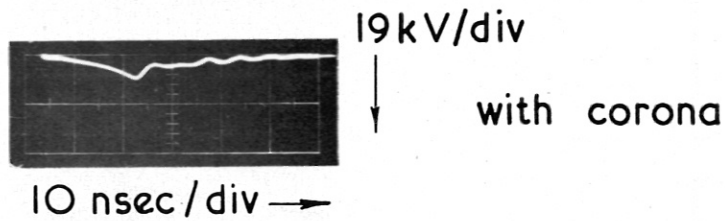
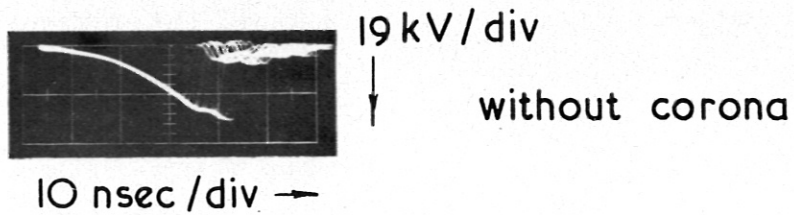


Fig. 7. Breakdown voltage and jitter in a sphere-sphere gap with corona-electrode.

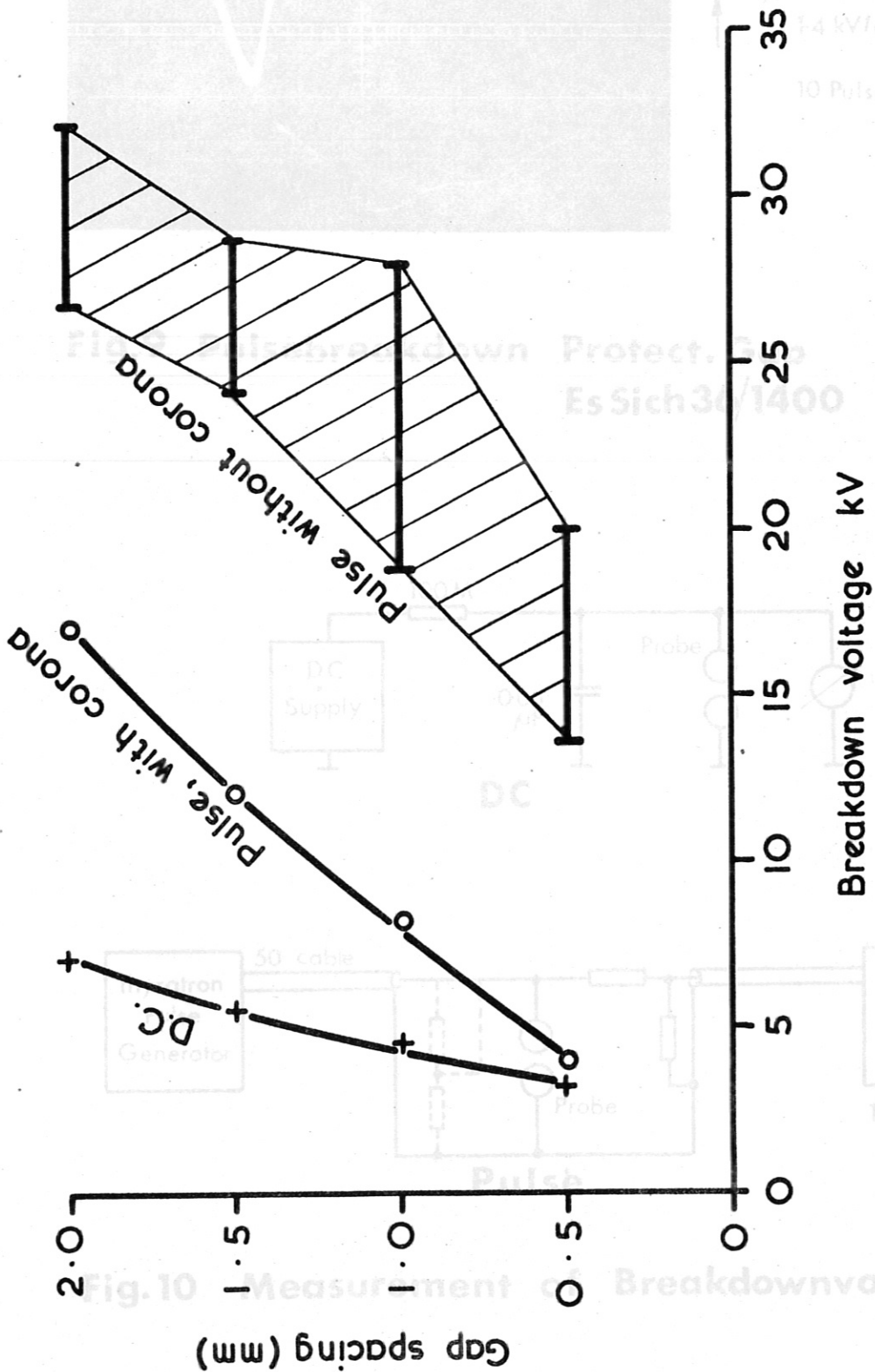
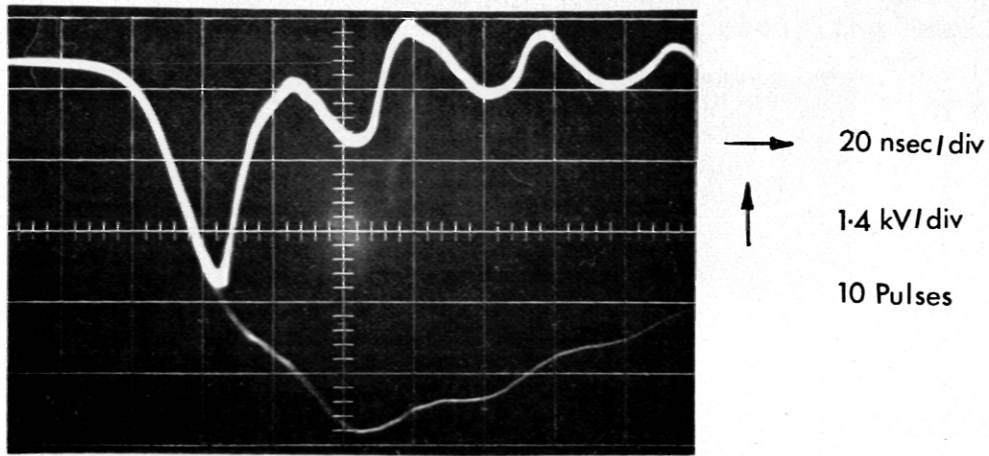


Figure 8 Breakdown voltage of Decoupling gap, final arrangement



**Fig.9 Pulsebreakdown Protect. Gap
Es Sich 36/1400**

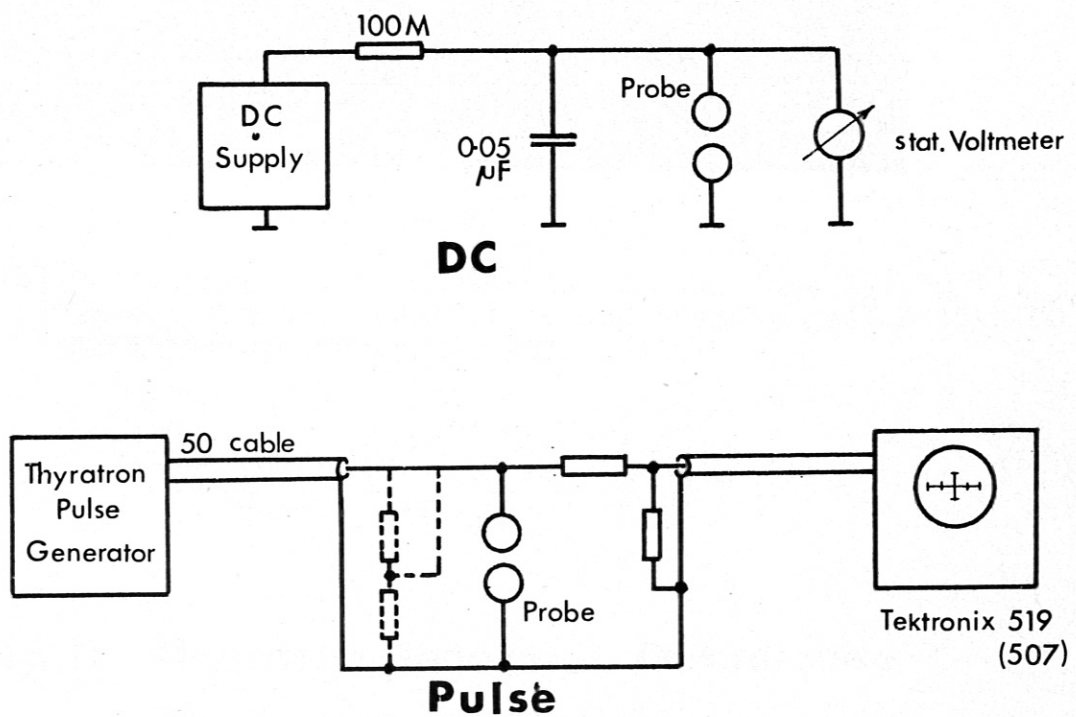
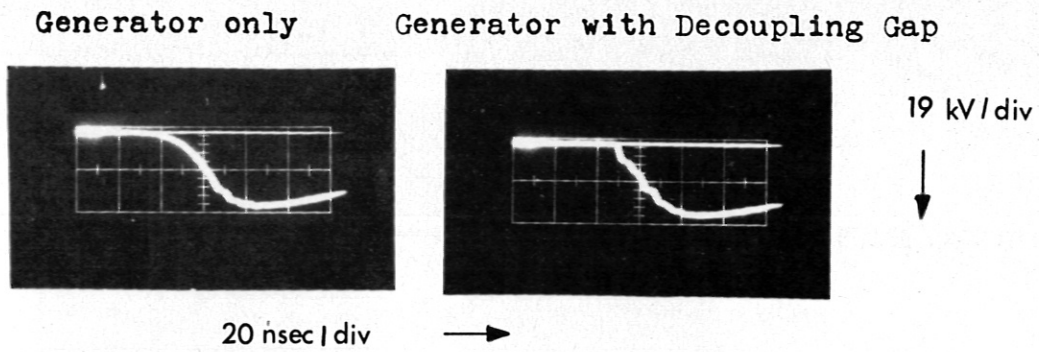
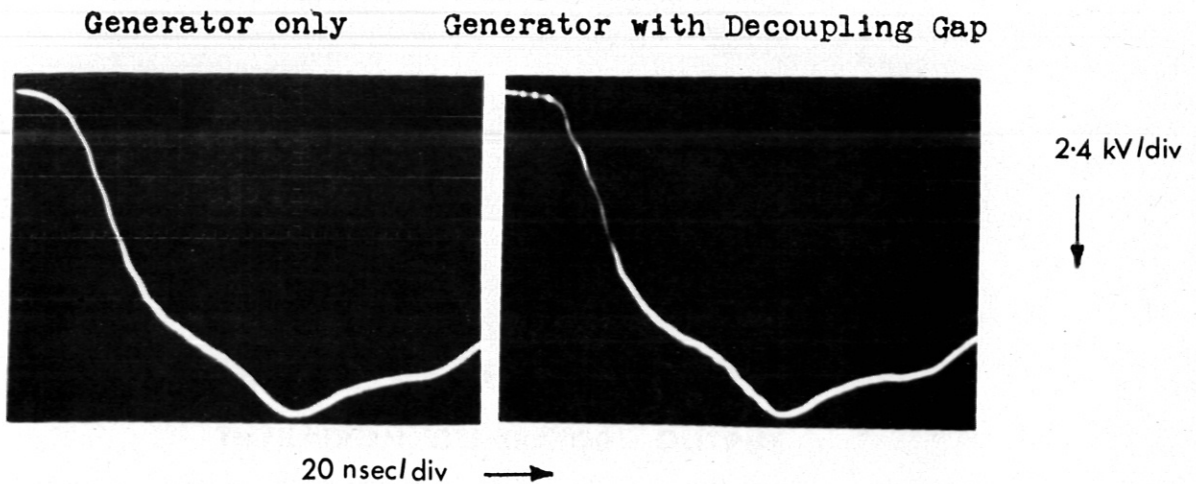


Fig.10 Measurement of Breakdownvoltage

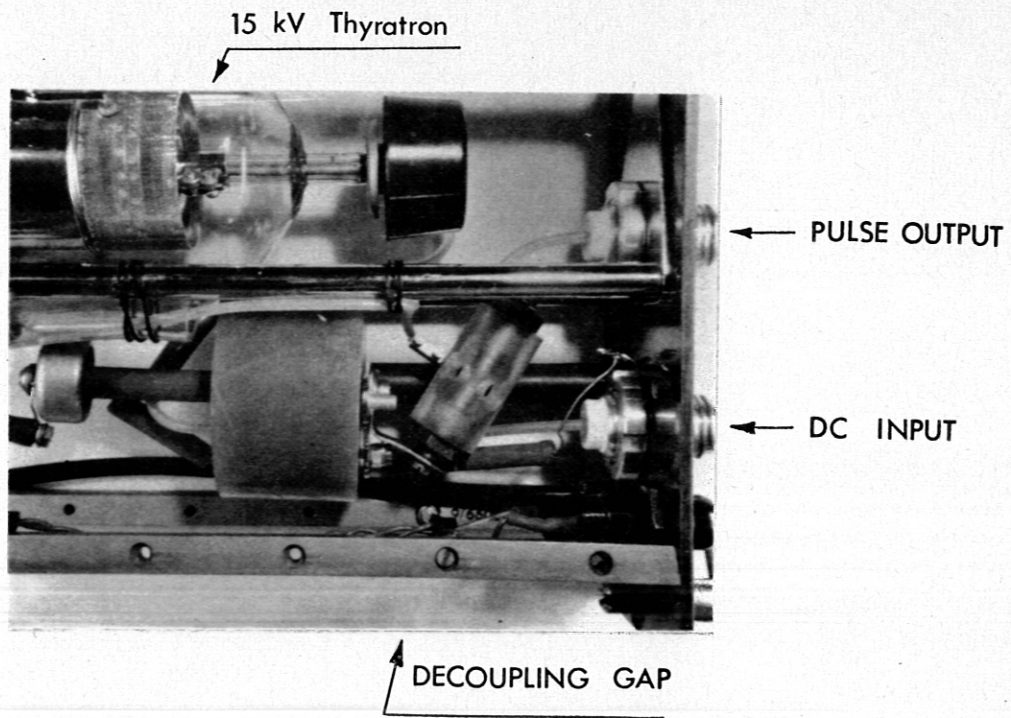


a) Generator pulse at open cable-end. Decoupling Gap: Corona Gap, 1 mm. Oscilloscope Tektr.519



b) Generator pulse at cable-end feeding into Z_0 (50 Ω).
Decoupling Gap: Protective Gap Siemens EsSich 36/1400
Oscilloscope Tektronix 507.

**Fig.11 Thyatron Generator Outputpulse
Effect of Decoupling Element**



**FIG. 12 EXAMPLE OF DECOUPLING GAP IN SITU OF
THYRATRON GENERATOR. OUTPUT**