

# DISCRETE EVENT SYSTEMS WITH STANDARD AND PARTIAL SYNCHRONIZATIONS

vorgelegt von  
M.Sc.  
Xavier David-Henriet  
geb. in Mülhausen

von der Fakultät IV - Elektrotechnik und Informatik  
der Technischen Universität Berlin  
zur Erlangung des akademischen Grades

Doktor der Ingenieurwissenschaften  
- Dr.-Ing. -

genehmigte Dissertation

Promotionsausschuss:

Vorsitzender: Prof. Dr. Rolf NIEDERMEIER Technische Universität Berlin  
stellv. Vorsitzender: Dr. Bertrand COTTENCEAU Université d'Angers  
Gutachter: Prof. Stéphane GAUBERT INRIA  
Gutachter: Prof. Dr.-Ing. Thomas MOOR Universität Erlangen-Nürnberg  
Gutachter: Prof. Laurent HARDOUIN Université d'Angers  
Gutachter: Prof. Dr.-Ing. Jörg RAISCH Technische Universität Berlin

Tag der wissenschaftlichen Aussprache: 19. März 2015

Berlin 2015



PhD Thesis

**DISCRETE EVENT SYSTEMS WITH STANDARD  
AND PARTIAL SYNCHRONIZATIONS**

XAVIER DAVID-HENRIET

Xavier David-Henriet: *Discrete Event Systems with Standard and Partial Synchronizations*  
PhD Thesis, © January 2015

SUPERVISORS:

Prof. Laurent Hardouin  
Prof. Dr.-Ing. Jörg Raisch

LOCATIONS:

Laboratoire Angevin de Recherche en Ingénierie des Systèmes, Université d'Angers, 62  
Avenue Notre-Dame du Lac, 49000 Angers, France  
Fachgebiet Regelungssysteme, Fakultät IV - Elektrotechnik und Informatik, Technische  
Universität Berlin, Einsteinufer 17, 10587 Berlin, Germany

# Abstract

---

Many transportation networks can be modeled by  $(\max, +)$ -linear systems, *i.e.*, discrete event systems ruled by standard synchronizations (conditions of the form: "for all  $k \geq l$ , occurrence  $k$  of event  $e_2$  is at least  $\tau$  units of time after occurrence  $k - l$  of event  $e_1$ "). In some applications, it is also necessary to model simultaneity between events (*e.g.*, for a road equipped with traffic lights, a vehicle can cross an intersection only *when* the associated traffic light is green). Such conditions cannot be expressed using standard synchronizations. Hence, we introduce the partial synchronization (condition of the form: "event  $e_2$  can only occur *when* event  $e_1$  occurs"). In this thesis, we consider a class of discrete event systems ruled by standard and partial synchronizations, called  $(\max, +)$ -systems with partial synchronization. Such systems are split into a main system and a secondary system such that there exist only standard synchronizations between events in the same system and partial synchronizations of events in the secondary system by events in the main system. We adapt some modeling and control approaches developed for  $(\max, +)$ -linear systems to  $(\max, +)$ -systems with partial synchronization. Optimal feedforward control and model predictive control for  $(\max, +)$ -linear systems are extended to  $(\max, +)$ -systems with partial synchronization. Furthermore, transfer relation and model reference control are provided for the secondary system under a predefined behavior of the main system.

Keywords: discrete event system, synchronization,  $(\max, +)$ -algebra, dioid, transportation network

## Résumé

---

De nombreux systèmes de transport peuvent être modélisés par des synchronisations ordinaires (pour tout  $k \geq l$ , l'occurrence  $k$  de l'événement  $e_2$  se produit au moins  $\tau$  unités de temps après l'occurrence  $k - l$  de l'événement  $e_1$ ). Ces systèmes sont linéaires dans l'algèbre  $(\max, +)$ . Pour certaines applications, il est primordial de modéliser la simultanéité entre événements (par exemple, un véhicule ne peut franchir un feu tricolore que quand celui-ci est vert). Comme la synchronisation ordinaire ne suffit pas à exprimer ce phénomène, nous introduisons la synchronisation partielle (l'événement  $e_2$  ne peut se produire que quand l'événement  $e_1$  se produit). Dans ce mémoire, des méthodes développées pour la modélisation et le contrôle de systèmes linéaires dans l'algèbre  $(\max, +)$  sont étendues à des systèmes régis par des synchronisations ordinaires et partielles. Nous considérons uniquement des systèmes divisés en un système principal et un système secondaire et gouvernés par des synchronisations ordinaires entre événements dans le même système et des synchronisations partielles d'événements dans le système secondaire par des événements dans le système principal. Nous introduisons une commande optimale et une commande prédictive pour cette classe de systèmes par analogie avec les résultats disponibles pour les systèmes linéaires dans l'algèbre  $(\max, +)$ . En considérant un comportement donné pour le système principal, il est aussi possible de représenter le système secondaire par une fonction de transfert et de modifier sa dynamique pour suivre un modèle de référence.

Mots clés : système à événements discrets, synchronisation, algèbre  $(\max, +)$ , diode, système de transport

# Zusammenfassung

---

Viele Verkehrsnetzwerke können mit Hilfe von Standardsynchronisationen (zum Beispiel, für  $k \geq l$ , das Auftreten  $k$  des Ereignisses  $e_2$  findet mindestens  $\tau$  Zeiteinheiten nach dem Auftreten  $k - l$  des Ereignisses  $e_1$  statt) modelliert werden. Eine interessante Eigenschaft solcher Systeme ist die Möglichkeit, sie als lineares System in der  $(\max, +)$ -Algebra abzubilden. Für viele Anwendungen ist eine Modellierung der Gleichzeitigkeit zwischen Ereignissen erforderlich (ein Fahrzeug kann, zum Beispiel, eine Kreuzung überqueren nur wenn die dazugehörige Ampel grün ist). Aus diesem Grund wird die partielle Synchronisation eingeführt. Formal ist die partielle Synchronisation durch die folgende Bedingung definiert: Ereignis  $e_2$  kann nur auftreten wenn Ereignis  $e_1$  auftritt. In dieser Arbeit wird eine Erweiterung der Methoden zur Modellierung und Steuerung von  $(\max, +)$ -linearen Systemen vorgestellt. Die betrachtete Systemklasse besteht aus Systemen geteilt in ein Hauptsystem und ein Nebensystem, so dass jede Synchronisation entweder einer Standardsynchronisation zwischen Ereignissen im selben System entspricht oder eine partielle Synchronisation eines Ereignisses im Nebensystem durch ein Ereignis im Hauptsystem darstellt. Analog zu  $(\max, +)$ -linearen Systemen werden optimale Steuerung und modellprädiktive Regelung für die oben gegebene Systemklasse eingeführt. Des Weiteren besteht die Möglichkeit, das Nebensystem als eine Übertragungsmatrix abzubilden, wenn das Verhalten des Hauptsystems vorgegeben ist. In diesem Sonderfall werden verfügbare Methoden zur Berechnung von Vorsteuerungen und Rückführungen für  $(\max, +)$ -lineare Systeme an dem Nebensystem angepasst.

Stichwörter: ereignisdiskretes System, Synchronisation,  $(\max, +)$ -Algebra, Dioidalgebra, Verkehrsnetzwerk





# Acknowledgments

---

At this point I would like to say *thank you* to all the people, who have contributed to this thesis, be it by discussion, inspiration, or different kinds of support.

In particular, I would like to thank my supervisors Prof. Hardouin and Prof. Raisch for giving me the opportunity to work in such an interesting field of research, for many discussions of my work, and for introducing me to so many nice people.

I would also like to thank Dr. Cottencaeu, Prof. Gaubert, Prof. Moor, and Prof. Niedermeier for reviewing my work.

I am also greatly emdebted to Dr. Thomas Brunsch for his benevolent and constructive guidance during my master's thesis and the first year of my PhD thesis.

A big *thank you* deserve the members and former members of the Control Systems Group at TU Berlin and of the Laboratoire Angevin de Recherche en Ingénierie des Systèmes at the Université d'Angers for letting me be a part of the group, for many discussions and support during my research. In particular, I would like to thank Soraia, Mickaël, Franziska, Olivier, Miguel, Behrang, Johannes, Rabah, Rémy, and Euriell.

I would also like to express my deep gratitude to Ulrike Locherer, Simone Rees, and Janine Holzmann, for smoothing the way towards my PhD degree with respect to many administrative issues.

Cuiming Song and Oriane David-Henriet deserve an extra *thank you* for making me experience real-world idempotency.

*Berlin, January 2015*

Xavier



# Contents

---

<b>1. Introduction</b>	<b>1</b>
<b>1. Algebraic Tools</b>	<b>5</b>
<b>2. Mathematical Preliminaries</b>	<b>7</b>
2.1. Residuation Theory . . . . .	7
2.2. Dioid . . . . .	8
2.2.1. Complete Dioid . . . . .	10
2.2.2. Subdioid . . . . .	14
2.3. Morphism . . . . .	16
2.3.1. Dioid of $\oplus$ -Morphisms . . . . .	18
2.4. Matrix Dioid . . . . .	20
2.4.1. Rational Representation . . . . .	22
2.5. Dioid of Formal Power Series . . . . .	23
2.5.1. Dioid of Isotone Formal Power Series . . . . .	25
2.6. Quotient Dioid . . . . .	26
2.6.1. Quotient Dioid of a Dioid of Formal Power Series . . . . .	27
2.7. Dioid $\overline{\mathbb{N}}_{\max, \gamma}[\gamma]$ . . . . .	28
2.7.1. Periodicity . . . . .	29
2.7.2. Rationality . . . . .	31
2.7.3. Realizability . . . . .	32
2.7.4. The Fundamental Theorem in $\overline{\mathbb{N}}_{\max, \gamma}[\gamma]$ . . . . .	32
<b>3. Dioid <math>\mathcal{F}_{\overline{\mathbb{N}}_{\max}}</math></b>	<b>33</b>
3.1. Projection on $\mathcal{F}_{\overline{\mathbb{N}}_{\max}}$ . . . . .	35
3.2. Subdioid $\mathcal{F}_{\Delta}$ . . . . .	39
3.3. Quasi-Causality and Causality . . . . .	40
3.4. Periodicity . . . . .	43
3.4.1. Calculation with Periodic Mappings . . . . .	44

3.5. Rationality . . . . .	49
<b>4. Dioid <math>\mathcal{F}_{\overline{\mathbb{N}}_{\max}, \gamma}[\Upsilon]</math></b>	<b>53</b>
4.1. Subdioid $\mathcal{F}_{\Delta, \gamma}[\Upsilon]$ . . . . .	58
4.2. Quasi-Causality and Causality . . . . .	59
4.3. Periodicity . . . . .	60
4.3.1. Canonical Representative of Periodic Series . . . . .	62
4.3.2. Calculation with Periodic Series . . . . .	68
4.3.3. Subdioid $\mathcal{F}_{\overline{\mathbb{N}}_{\max}, \gamma}^{\text{per}, c}[\Upsilon]$ . . . . .	71
4.4. Rationality . . . . .	72
4.5. Realizability . . . . .	73
4.6. The Fundamental Theorem in $\mathcal{F}_{\overline{\mathbb{N}}_{\max}, \gamma}[\Upsilon]$ . . . . .	75
<b>II. System and Control Theory</b>	<b>77</b>
<b>5. Modeling</b>	<b>79</b>
5.1. Conventions . . . . .	82
5.1.1. Input, Output, and State Events . . . . .	82
5.1.2. Petri Net Representation . . . . .	83
5.1.3. Earliest Functioning Rule . . . . .	84
5.2. Dater Representation . . . . .	84
5.2.1. Daters . . . . .	85
5.2.2. Expressing Synchronizations with Daters . . . . .	86
5.2.3. Input-Output Behavior . . . . .	91
<b>6. Optimal Control</b>	<b>97</b>
6.1. Optimal Feedforward Control . . . . .	98
6.1.1. Feasibility . . . . .	104
6.1.2. Characterization with Cost Functions . . . . .	106
6.1.3. Complexity . . . . .	109
6.2. Model Predictive Control . . . . .	110
<b>7. Operatorial Representation</b>	<b>119</b>
7.1. Algebraic Definition of Operatorial Representation . . . . .	120
7.1.1. Transfer Function Matrix . . . . .	122
7.1.2. Composition Operators . . . . .	123
7.2. Operatorial Representation for $(\max, +)$ -linear Systems . . . . .	129
7.3. Operatorial Representation for $(\max, +)$ -systems Subject to Partial Syn- chronization . . . . .	131
7.3.1. Periodic Case . . . . .	132

<b>8. Model Reference Control</b>	<b>141</b>
8.1. Prefilter . . . . .	142
8.2. Feedback . . . . .	144
<b>9. Conclusion</b>	<b>149</b>
<b>III. Appendices</b>	<b>153</b>
<b>A. Proofs</b>	<b>155</b>
A.1. Calculation with Periodic Series in $\mathcal{F}_{\overline{\mathbb{N}}_{\max}, \gamma}[\gamma]$ . . . . .	155
A.1.1. Sum of Periodic Series . . . . .	155
A.1.2. Greatest Lower Bound of Periodic Series . . . . .	156
A.1.3. Product of Periodic Series . . . . .	163
A.1.4. Left-Division of Quasi-Causal Periodic Series . . . . .	166
A.1.5. Kleene Star of Causal Periodic Series . . . . .	176
A.2. Calculation with Series in $\mathcal{F}_{\overline{\mathbb{N}}_{\max}, \gamma}^{\text{per}, c}[\gamma]$ . . . . .	185
A.2.1. Sum of Series in $\mathcal{F}_{\overline{\mathbb{N}}_{\max}, \gamma}^{\text{per}, c}[\gamma]$ . . . . .	185
A.2.2. Greatest Lower Bound of Series in $\mathcal{F}_{\overline{\mathbb{N}}_{\max}, \gamma}^{\text{per}, c}[\gamma]$ . . . . .	186
A.2.3. Product of Series in $\mathcal{F}_{\overline{\mathbb{N}}_{\max}, \gamma}^{\text{per}, c}[\gamma]$ . . . . .	186
A.2.4. Left-Division of Series in $\mathcal{F}_{\overline{\mathbb{N}}_{\max}, \gamma}^{\text{per}, c}[\gamma]$ . . . . .	188
A.2.5. Right-Division of Series in $\mathcal{F}_{\overline{\mathbb{N}}_{\max}, \gamma}^{\text{per}, c}[\gamma]$ . . . . .	195
<b>B. Modeling with Counters</b>	<b>207</b>
B.1. Mathematical Preliminaries . . . . .	207
B.2. Counter Representation . . . . .	208
B.2.1. Counters . . . . .	208
B.2.2. Expressing Synchronizations with Counters . . . . .	209
B.2.3. Input-Output Behavior . . . . .	214
<b>Bibliography</b>	<b>221</b>

# List of Figures

---

1.1.	A schematic view of a $(\max, +)$ -system with partial synchronization . . . .	2
2.1.	Series $s = 1\gamma \oplus 4\gamma^3$ . . . . .	29
2.2.	Series $s = 3 \oplus 4\gamma^2 \oplus (6\gamma^3 \oplus 8\gamma^4) (3\gamma^2)^*$ . . . . .	31
4.1.	Series $s = \gamma \oplus f\gamma^3$ . . . . .	57
4.2.	Series $s = \gamma \oplus \Delta^3\gamma^3$ . . . . .	59
4.3.	Series $s = f_1 \oplus (\Delta^2\gamma)^* f_2 \oplus (\Delta^3\gamma)^* f_3$ . . . . .	62
5.1.	A schematic view of a $(\max, +)$ -system with partial synchronization . . . .	79
5.2.	The supply chain and the train line . . . . .	80
5.3.	Graphical representation of a standard synchronization . . . . .	83
5.4.	Graphical representation of a partial synchronization . . . . .	84
5.5.	Petri net representation of the supply chain and of the train line . . . . .	85
5.6.	Equivalent synchronizations if no other synchronizations affect event $e_1$ . . . .	88
5.7.	A simple $(\max, +)$ -system with partial synchronization . . . . .	94
6.1.	A simple $(\max, +)$ -system with partial synchronization . . . . .	103
7.1.	Petri net representation of the road equipped with traffic lights . . . . .	121
7.2.	Petri net representation of the train line . . . . .	130
7.3.	Transfer function of the road equipped with traffic lights . . . . .	135
7.4.	Petri net representation of a $(\max, +)$ -system subject to partial synchronization exhibiting impulse responses with different throughputs . . . . .	138
7.5.	Transfer function $\mathcal{H} = e \oplus (\Delta^2\gamma)^* f$ . . . . .	139
8.1.	Model reference control with prefilter . . . . .	142
8.2.	Neutral prefilter for the road equipped with traffic lights . . . . .	144
8.3.	Realization of the neutral prefilter for the road equipped with traffic lights . . . . .	145
8.4.	Model reference control with output feedback . . . . .	146
8.5.	Neutral feedback for the road equipped with traffic lights . . . . .	148
8.6.	Realization of the neutral feedback for the road equipped with traffic lights . . . . .	148

B.1. Equivalent synchronizations if no other synchronizations affect event  $e_i$  . . . 212





# Introduction

---

A discrete event system (*e.g.*, [6]) is a dynamical system driven by the instantaneous occurrence of events. In a discrete event system, two basic elements are distinguished: the set of events and the rule describing the admissible behaviors of the system. Many formal approaches have been investigated to express this rule such as finite-state automata (*e.g.*, [28]) and Petri nets (*e.g.*, [33]). In some applications, time plays an important role in the dynamics of the system. Therefore, the rule describing the admissible behaviors of the system can be equipped with time. This gives rise to timed versions of the previous approaches, namely timed automata and timed Petri nets. Depending on the selected modeling approaches, different theories, such as supervisory control theory for finite-state automata [35] or state-based control for Petri nets (*e.g.*, [27]), have been introduced to tackle control problems. During the last decades, the framework of discrete event systems has been widely applied to model, analyze, and control both man-made systems such as manufacturing systems (*e.g.*, [5]) or transportation networks (*e.g.*, [26]) and natural systems such as biological systems (*e.g.*, [17]).

In this thesis, we focus on discrete event systems where the rule describing the admissible behaviors is only composed of synchronizations (*i.e.*, conditions on the timed behavior of one event in relation to one event). A well-known synchronization is the standard synchronization and corresponds to the following condition: for all  $k \geq l$ , occurrence  $k$  of event  $e_2$  is at least  $\tau$  units of time after occurrence  $k - l$  of event  $e_1$  with  $\tau \in \mathbb{R}_0^+$  and  $l \in \mathbb{N}_0$ . Discrete event systems where the rule describing the admissible behaviors is only composed of standard synchronizations are called  $(\max, +)$ -linear systems. This termi-

nology is due to the fact that a specific behavior namely the behavior under the earliest functioning rule is described by linear equations in particular algebraic structures such as the  $(\max, +)$ -algebra. In the literature, only this specific behavior is usually considered. For  $(\max, +)$ -linear systems, it is possible to partition the set of events into input, state, and output events and based on this partition to derive a  $(\max, +)$ -linear state-space model of the system. Therefore, much effort has been made during the last decades to adapt key concepts from standard control theory to  $(\max, +)$ -linear systems. Transfer function matrices have been introduced for  $(\max, +)$ -linear systems by using formal power series [1, 8, 22, 32]. Furthermore, some standard control approaches such as optimal feedforward control [9, 31], model reference control [14, 30], and model predictive control [20, 34] have been extended to  $(\max, +)$ -linear systems. Graphically,  $(\max, +)$ -linear systems are represented by a class of timed Petri nets, namely timed event graphs. Other synchronizations have recently been investigated. In [21], soft synchronization is introduced: a soft synchronization is a standard synchronization which can be occasionally ignored by paying a penalty. In [18], partial synchronization is defined by the following condition: event  $e_2$  can only occur *when*, not after, event  $e_1$  occurs.

The main contributions of our work relate to  $(\max, +)$ -systems with partial synchronization. Such systems have a rule described by standard and partial synchronizations and are split into a main system and a secondary system such that there exist only standard synchronizations between events in the same system and partial synchronizations (represented by dashed arrows in Fig. 1.1) of events in the secondary system by events in the main system. The main system corresponds to a  $(\max, +)$ -linear system, as the synchronizations affecting an event in the main system are standard synchronizations by events in the main system. However, due to partial synchronization, some events in the secondary system can occur only *when*, not after, associated events in the main system occur. Therefore, the modeling and control methods developed for  $(\max, +)$ -linear systems cannot be directly extended to  $(\max, +)$ -systems with partial synchronization. In this thesis, we investigate how to adapt some of these methods to  $(\max, +)$ -systems with partial synchronization.

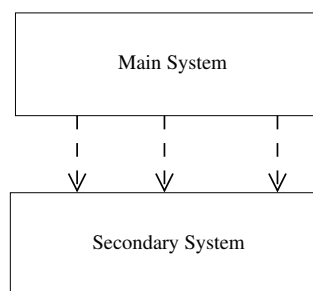

Figure 1.1.: A schematic view of a  $(\max, +)$ -system with partial synchronization

Before giving the structure of the thesis, let us briefly illustrate the practical interest of

---

(max, +)-systems with partial synchronization. The main system often offers a service for a time window to the secondary system. Furthermore, while obtaining this service is essential for the secondary system, the secondary system does not affect the main system. In the following, two concrete examples of (max, +)-systems with partial synchronization are introduced. The first example (discussed in detail in § 7 and § 8) considers a road network subject to traffic lights. The traffic lights solve the resource allocation problems at intersections and give permission to vehicles to cross intersections for time windows. This is expressed by partial synchronizations: a vehicle can cross an intersection only *when* the associated traffic light is green. Furthermore, while the color of a traffic light affects the behavior of the vehicles, the presence or absence of vehicles at an intersection is irrelevant for the associated traffic lights. In this example, the main system corresponds to the traffic lights and the secondary system corresponds to the road network. In the second example (discussed in detail in § 5 and in § 6), a supply chain for intermodal containers shuttling back and forth between warehouses  $A_1$  and  $B_1$  is investigated. The supply chain is divided in three sections: a road transport section between warehouse  $A_1$  and train station  $A$ , a rail transport section between train stations  $A$  and  $B$ , and a road transport section between train station  $B$  and warehouse  $B_1$ . The train line offers the service of transporting containers between train stations  $A$  and  $B$  for a time window, *i.e.*, this service can start only *when* a train is leaving the train station. Furthermore, while taking a train is a necessary step in the supply chain, not taking a container does not affect the train. In this example, the main system corresponds to the train line and the secondary system corresponds to the supply chain.

This thesis is divided in two parts. The first part focuses on the mathematical aspects and is structured as follows:

**Chapter 2** provides a broad overview of general mathematical concepts, mainly residuation theory and dioid (or idempotent semiring). Furthermore, some classical results related to the dioid  $\overline{\mathbb{N}}_{\max, \gamma}[\![\gamma]\!]$  are summarized. In particular, the fundamental theorem linking periodicity, rationality, and realizability in  $\overline{\mathbb{N}}_{\max, \gamma}[\![\gamma]\!]$  is recalled.

**Chapter 3** introduces the dioid of residuated mappings over  $\overline{\mathbb{N}}_{\max}$ , denoted  $\mathcal{F}_{\overline{\mathbb{N}}_{\max}}$ , and the concepts of causality, periodicity, and rationality are discussed in  $\mathcal{F}_{\overline{\mathbb{N}}_{\max}}$ .

**Chapter 4** defines, by analogy with  $\overline{\mathbb{N}}_{\max, \gamma}[\![\gamma]\!]$ , the dioid  $\mathcal{F}_{\overline{\mathbb{N}}_{\max, \gamma}[\![\gamma]\!]}$ . The concepts of causality, periodicity, rationality, and realizability are extended to  $\mathcal{F}_{\overline{\mathbb{N}}_{\max, \gamma}[\![\gamma]\!]}$ . This leads to a fundamental theorem in  $\mathcal{F}_{\overline{\mathbb{N}}_{\max, \gamma}[\![\gamma]\!]}$  similar to the one obtained in  $\overline{\mathbb{N}}_{\max, \gamma}[\![\gamma]\!]$ . Furthermore, left- and right-divisions are investigated in  $\mathcal{F}_{\overline{\mathbb{N}}_{\max, \gamma}[\![\gamma]\!]}$ .

The second part makes explicit how to use the mathematical tools discussed in the first part to model and control (max, +)-systems with partial synchronization.

**Chapter 5** focuses on the modeling of (max, +)-systems with partial synchronization. Similarly to (max, +)-linear systems, the timed behavior can be captured by daters. This leads to a model in the (max, +)-algebra.

**Chapter 6** describes optimal control for  $(\max, +)$ -systems with partial synchronization based on the model discussed in § 5. Optimal feedforward control and its closed-loop version, namely model predictive control, are presented.

**Chapter 7** focuses on operatorial representation. An operatorial representation for  $(\max, +)$ -systems with partial synchronization is not available. Then, only an operatorial representation for a particular dynamics of  $(\max, +)$ -systems with partial synchronization is considered: the dynamics of the secondary system under a predefined behavior of the main system. In the following, such a system is called a  $(\max, +)$ -system subject to partial synchronization. The suitable algebraic structure for the associated operatorial representation is the dioid  $\mathcal{F}_{\overline{\mathbb{N}}_{\max, \gamma}}[[\gamma]]$ . This leads to transfer function matrices for  $(\max, +)$ -systems subject to partial synchronization and clarifies, in terms of system theory, the meaning of the fundamental theorem in  $\mathcal{F}_{\overline{\mathbb{N}}_{\max, \gamma}}[[\gamma]]$ .

**Chapter 8** adapts some results of model reference control developed for  $(\max, +)$ -linear systems to  $(\max, +)$ -systems subject to partial synchronization. This approach based on operatorial representation aims at matching the dynamics of the system with a predefined model reference. In particular, the concepts of prefilter and feedback are investigated.

**Part I.**

**Algebraic Tools**



## Mathematical Preliminaries

---

In this chapter, the mathematical concepts on which this thesis is based are defined. These concepts are mainly related to residuation theory and dioid theory. Most of the following definitions and results are directly taken from the literature. Some minor contributions are, as far as we know, Prop. 1 and Lem. 3.

### 2.1. Residuation Theory

In the following, some basic concepts and results of residuation theory are recalled. A survey is available in [3, 4, 7].

**Definition 1** (Isotone mapping). *Let  $f : E \rightarrow F$  with  $E$  and  $F$  ordered sets. Mapping  $f$  is said to be isotone if*

$$\forall x, y \in E, \quad x \leq y \Rightarrow f(x) \leq f(y)$$

**Definition 2** (Residuated mapping). *Let  $f : E \rightarrow F$  with  $E$  and  $F$  ordered sets. Mapping  $f$  is said to be residuated if  $f$  is isotone and if, for all  $y \in F$ , the least upper bound of the subset  $\{x \in E \mid f(x) \leq y\}$  exists and lies in this subset. This element in  $E$  is denoted  $f^\sharp(y)$ . Mapping  $f^\sharp$  from  $F$  to  $E$  is called the residual of  $f$ .*

The following theorem characterizes residuated mappings.

**Theorem 1** ([3]). *Let  $f : E \rightarrow F$  with  $E$  and  $F$  ordered sets. The following statements are equivalent:*

1.  $f$  is residuated
2.  $f$  is isotone and there is an isotone mapping  $g : F \rightarrow E$  such that  $g \circ f \geq \text{Id}_E$  and  $f \circ g \leq \text{Id}_F$

Furthermore, if  $f$  is residuated, the mapping  $g$  in the second condition is unique and corresponds to the residual of  $f$ .

Duality leads to dual versions of Def. 2 and Th. 1.

**Definition 3** (Dually residuated mapping). *Let  $f : E \rightarrow F$  with  $E$  and  $F$  ordered sets. Mapping  $f$  is said to be dually residuated if  $f$  is isotone and if, for all  $y \in F$ , the greatest lower bound of the subset  $\{x \in E \mid f(x) \geq y\}$  exists and lies in this subset. This element in  $E$  is denoted  $f^\flat(y)$ . Mapping  $f^\flat$  from  $F$  to  $E$  is called the dual residual of  $f$ .*

**Theorem 2** ([3]). *Let  $f : E \rightarrow F$  with  $E$  and  $F$  ordered sets. The following statements are equivalent:*

1.  $f$  is dually residuated
2.  $f$  is isotone and there is an isotone mapping  $g : F \rightarrow E$  such that  $g \circ f \leq \text{Id}_E$  and  $f \circ g \geq \text{Id}_F$

Furthermore, if  $f$  is dually residuated, the mapping  $g$  in the second condition is unique and corresponds to the dual residual of  $f$ .

**Remark 1.** *make explicit a link between residuated mappings and dually residuated mappings. If a mapping  $f$  is residuated, then its residual  $f^\sharp$  is dually residuated and  $(f^\sharp)^\flat = f$ . Dually, if a mapping  $f$  is dually residuated, then its dual residual  $f^\flat$  is residuated and  $(f^\flat)^\sharp = f$ .*

## 2.2. Dioid

Dioids (or idempotent semirings) are algebraic structures which play a major role in the rest of this thesis. Some basic definitions of dioid theory are recalled in this section. A more exhaustive discussion is available in [1].

**Definition 4** (Dioid). *A dioid is a set  $\mathcal{D}$  endowed with two binary operations, denoted  $\oplus$  and  $\otimes$ , such that:*

- $\oplus$  is associative, commutative, idempotent ( $\forall a \in \mathcal{D}, a \oplus a = a$ ), and admits a neutral element  $\varepsilon$ .
- $\otimes$  is associative and admits a neutral element  $e$ .
- $\otimes$  is distributive with respect to  $\oplus$  from both sides:

$$\forall a, b, c \in \mathcal{D}, \quad \begin{cases} a \otimes (b \oplus c) = (a \otimes b) \oplus (a \otimes c) \\ (a \oplus b) \otimes c = (a \otimes c) \oplus (b \otimes c) \end{cases}$$



–  $\varepsilon$  is absorbing for  $\otimes$ :

$$\forall a \in \mathcal{D}, \quad a \otimes \varepsilon = \varepsilon \otimes a = \varepsilon$$

If  $\otimes$  is commutative, then dioid  $\mathcal{D}$  is said to be commutative.

Formally, the operations  $\oplus$  and  $\otimes$  are very similar to  $+$  and  $\times$  in rings. Therefore, these operations are respectively called addition and multiplication. Then,  $\varepsilon$  is the zero element of the dioid  $\mathcal{D}$  and  $e$  is its unit element. As in classical algebra,  $\otimes$  is often omitted and the multiplication of two elements is simply denoted by juxtaposition (i.e.,  $a \otimes b$  is denoted  $ab$ ).

**Remark 2.** In the literature, dioid might refer to slightly different algebraic structures. In [29],  $\oplus$  is not idempotent and  $\varepsilon$  is not absorbing for  $\otimes$ . In [32],  $\oplus$  is not idempotent, but  $\varepsilon$  is absorbing for  $\otimes$ . In [24],  $\oplus$  is not idempotent, but  $\varepsilon$  is absorbing for  $\otimes$  and another condition on  $\oplus$  is given:

$$\forall a, b \in \mathcal{D}, \quad (\exists c_1, c_2 \in \mathcal{D}, a = b \oplus c_1 \text{ and } b = a \oplus c_2) \Rightarrow a = b$$

Clearly, the previous condition holds if  $\oplus$  is idempotent.

As  $\oplus$  is associative, commutative, and idempotent, it induces an order  $\leq$  on  $\mathcal{D}$  defined by  $a \leq b \Leftrightarrow a \oplus b = b$ . Therefore, a dioid is an ordered set admitting the bottom element  $\varepsilon$ , i.e.,  $\forall a \in \mathcal{D}, \varepsilon \leq a$ . Furthermore, the least upper bound of  $\{a, b\} \subseteq \mathcal{D}$  corresponds to  $a \oplus b$ . Due to the distributivity of  $\otimes$  with respect to  $\oplus$  from both sides, the product by a constant is isotone. Formally,

$$\forall c \in \mathcal{D}, \quad a \leq b \Rightarrow \begin{cases} ac \leq bc \\ ca \leq cb \end{cases}$$

**Remark 3.** Let  $\mathcal{S}$  be a set and let  $\mathcal{D}$  be a dioid. The set of mappings from  $\mathcal{S}$  to  $\mathcal{D}$ , denoted  $\mathcal{M}(\mathcal{S}, \mathcal{D})$ , is endowed by an operation  $\oplus$  and an order  $\leq$  induced by the operation  $\oplus$  and the order  $\leq$  on  $\mathcal{D}$ . Formally, for  $f_1, f_2 \in \mathcal{M}(\mathcal{S}, \mathcal{D})$ ,

$$\begin{aligned} \forall s \in \mathcal{S}, \quad (f_1 \oplus f_2)(s) &= f_1(s) \oplus f_2(s) \\ f_1 \leq f_2 &\Leftrightarrow \forall s \in \mathcal{S}, f_1(s) \leq f_2(s) \end{aligned}$$

**Definition 5** (Selective dioid). A dioid  $\mathcal{D}$  is said to be selective if,  $\forall a, b \in \mathcal{D}$ ,  $a \oplus b$  is equal either to  $a$  or to  $b$ .

**Example 1** (Dioid  $\mathbb{R}_{\max}$ ). The set  $\mathbb{R}_0^+ \cup \{-\infty\}$  endowed with  $\max$  as addition and  $+$  as multiplication is a dioid denoted  $\mathbb{R}_{\max}$ . Its zero element  $\varepsilon$  is equal to  $-\infty$  and its unit element  $e$  is equal to  $0$ . The order induced by  $\oplus$  coincides with the standard order in  $\mathbb{R}_0^+$ . Obviously, dioid  $\mathbb{R}_{\max}$  is selective and commutative. This dioid (along with other dioids using  $\max$  as addition and  $+$  as multiplication) is often called  $(\max, +)$ -algebra in the literature.

### 2.2.1. Complete Dioid

**Definition 6** (Complete dioid). A dioid  $\mathcal{D}$  is said to be complete if it is closed for infinite sums and if distributivity is extended to infinite sums. Formally, for all subsets  $\mathcal{X}$  of  $\mathcal{D}$ ,

$$\bigoplus_{x \in \mathcal{X}} x \in \mathcal{D} \text{ and } \forall a \in \mathcal{D}, \begin{cases} a \otimes (\bigoplus_{x \in \mathcal{X}} x) = \bigoplus_{x \in \mathcal{X}} (a \otimes x) \\ (\bigoplus_{x \in \mathcal{X}} x) \otimes a = \bigoplus_{x \in \mathcal{X}} (x \otimes a) \end{cases}$$

In a complete dioid  $\mathcal{D}$ ,  $\bigoplus_{x \in \mathcal{D}} x$ , denoted  $\top$ , belongs to  $\mathcal{D}$ . Then, dioid  $\mathcal{D}$  admits  $\top$  as top element, i.e.,  $\forall a \in \mathcal{D}$ ,  $a \leq \top$ . A new binary operation  $\wedge$  is defined on a complete dioid  $\mathcal{D}$  by

$$a \wedge b = \bigoplus_{x \in \mathcal{D}_{a,b}} x \text{ with } \mathcal{D}_{a,b} = \{x \in \mathcal{D} | x \leq a \text{ and } x \leq b\}$$

Obviously,  $\wedge$  is commutative, idempotent, and associative. Furthermore,  $\wedge$  admits  $\top$  as neutral element in  $\mathcal{D}$ . Dioid  $\mathcal{D}$  is stable for  $\wedge$ -operation over infinite sets. For all subsets  $\mathcal{Y}$  of  $\mathcal{D}$ ,

$$\bigwedge_{y \in \mathcal{Y}} y = \bigoplus_{x \in \mathcal{D}_{\mathcal{Y}}} x \text{ with } \mathcal{D}_{\mathcal{Y}} = \{x \in \mathcal{D} | \forall y \in \mathcal{Y}, x \leq y\}$$

Furthermore, the greatest lower bound of  $\{a, b\} \subseteq \mathcal{D}$  corresponds to  $a \wedge b$ .

**Remark 4.** In general,  $\otimes$  is not distributive with respect to  $\wedge$ . But, since the multiplication by a constant is isotone,

$$\forall a, b, c \in \mathcal{D}, \quad a(b \wedge c) \leq ab \wedge ac \text{ and } (a \wedge b)c \leq ac \wedge bc$$

In selective dioids,  $\otimes$  is distributive with respect to  $\wedge$  from both sides, i.e.,

$$\forall a, b, c \in \mathcal{D}, \quad a(b \wedge c) = ab \wedge ac \text{ and } (a \wedge b)c = ac \wedge bc$$

In general,  $\oplus$  is not distributive with respect to  $\wedge$  and  $\wedge$  is not distributive with respect to  $\oplus$ . However,

$$\forall a, b, c \in \mathcal{D}, \quad a \oplus (b \wedge c) \leq (a \oplus b) \wedge (a \oplus c) \tag{2.1}$$

$$\forall a, b, c \in \mathcal{D}, \quad a \wedge (b \oplus c) \geq (a \wedge b) \oplus (a \wedge c) \tag{2.2}$$

In [1], distributive dioids are defined as complete dioids where equality holds in (2.1) and (2.2).

**Definition 7** (Distributive dioid). A dioid  $\mathcal{D}$  is said to be distributive if it is complete and, for all subsets  $\mathcal{X}$  of  $\mathcal{D}$ ,

$$\forall a \in \mathcal{D}, \quad \begin{cases} a \oplus (\bigwedge_{x \in \mathcal{X}} x) = \bigwedge_{x \in \mathcal{X}} (a \oplus x) \\ a \wedge (\bigoplus_{x \in \mathcal{X}} x) = \bigoplus_{x \in \mathcal{X}} (a \wedge x) \end{cases}$$

**Lemma 1.** *Let  $\mathcal{D}$  be a complete selective dioid. Then,  $\mathcal{D}$  is distributive.*

*Proof.* It remains to show that, for all subsets  $\mathcal{X}$  of  $\mathcal{D}$ ,

$$\forall \mathbf{a} \in \mathcal{D}, \quad \begin{cases} \mathbf{a} \oplus (\bigwedge_{x \in \mathcal{X}} x) = \bigwedge_{x \in \mathcal{X}} (\mathbf{a} \oplus x) \\ \mathbf{a} \wedge (\bigoplus_{x \in \mathcal{X}} x) = \bigoplus_{x \in \mathcal{X}} (\mathbf{a} \wedge x) \end{cases}$$

Only the first equality is considered. The result for the second equality is obtained by duality. As  $\mathcal{D}$  is selective,  $\mathbf{a} \oplus (\bigwedge_{x \in \mathcal{X}} x)$  is either equal to  $\bigwedge_{x \in \mathcal{X}} x$  or equal to  $\mathbf{a}$ .

If  $\mathbf{a} \oplus (\bigwedge_{x \in \mathcal{X}} x) = \bigwedge_{x \in \mathcal{X}} x$ , then, for all  $x \in \mathcal{X}$ ,  $x \geq \mathbf{a}$ . Thus,

$$\mathbf{a} \oplus \left( \bigwedge_{x \in \mathcal{X}} x \right) = \bigwedge_{x \in \mathcal{X}} x = \bigwedge_{x \in \mathcal{X}} (\mathbf{a} \oplus x)$$

Otherwise,  $\mathbf{a} \oplus (\bigwedge_{x \in \mathcal{X}} x) = \mathbf{a}$  and  $\mathbf{a} > \bigwedge_{x \in \mathcal{X}} x$ . Then, there exists  $x' \in \mathcal{X}$  such that  $x' \not\geq \mathbf{a}$ . Consequently, as  $\mathcal{D}$  is a selective dioid,  $\mathbf{a} \oplus x' = \mathbf{a}$ . Thus,

$$\mathbf{a} = \mathbf{a} \oplus x' \geq \bigwedge_{x \in \mathcal{X}} (\mathbf{a} \oplus x) \geq \mathbf{a}$$

□

**Example 2** (Dioid  $\overline{\mathbb{R}}_{\max}$ ). *The set  $\mathbb{R}_0^+ \cup \{-\infty, +\infty\}$  endowed with  $\max$  as addition and  $+$  as multiplication is a complete dioid denoted  $\overline{\mathbb{R}}_{\max}$ . Its zero element  $\varepsilon$  is equal to  $-\infty$ , its unit element  $e$  is equal to  $0$ , and its top element  $\top$  is equal to  $+\infty$ . The order induced by  $\oplus$  coincides with the standard order in  $\mathbb{R}_0^+$ . Obviously,  $\overline{\mathbb{R}}_{\max}$  is selective and commutative. Therefore, according to Lem. 1,  $\overline{\mathbb{R}}_{\max}$  is distributive.*

**Example 3** (Dioid  $\overline{\mathbb{N}}_{\max}$ ). *The set  $\mathbb{N}_0 \cup \{-\infty, +\infty\}$  endowed with  $\max$  as addition and  $+$  as multiplication is a complete dioid denoted  $\overline{\mathbb{N}}_{\max}$ . Its zero element  $\varepsilon$  is equal to  $-\infty$ , its unit element  $e$  is equal to  $0$ , and its top element  $\top$  is equal to  $+\infty$ . The order induced by  $\oplus$  coincides with the standard order in  $\mathbb{N}_0$ . Obviously,  $\overline{\mathbb{N}}_{\max}$  is selective and commutative. Therefore, according to Lem. 1,  $\overline{\mathbb{N}}_{\max}$  is distributive.*

**Example 4** (Boolean dioid  $\mathbb{B}$ ). *The Boolean dioid  $\mathbb{B} = \{\varepsilon, e\}$  is the dioid composed of  $\varepsilon$  and  $e$ . Dioid  $\mathbb{B}$  is complete, commutative, and selective. Therefore, according to Lem. 1,  $\mathbb{B}$  is distributive.*

### Residuation Theory in Complete Dioids

In the following, residuation theory is investigated when the considered ordered sets are complete dioids.

**Definition 8** (Lower semi-continuity). A mapping  $f$  from complete dioid  $\mathcal{D}_1$  to complete dioid  $\mathcal{D}_2$  is said to be lower semi-continuous if

$$\forall \mathcal{X} \subseteq \mathcal{D}_1, \quad f \left( \bigoplus_{x \in \mathcal{X}} x \right) = \bigoplus_{x \in \mathcal{X}} f(x)$$

The next result gives a very handy characterization of residuated mappings when the considered ordered sets are complete dioids.

**Theorem 3** ([1]). Let  $f : \mathcal{D}_1 \rightarrow \mathcal{D}_2$  with  $\mathcal{D}_1$  and  $\mathcal{D}_2$  complete dioids. The following statements are equivalent:

1.  $f$  is residuated
2.  $f$  is lower semi-continuous and  $f(\varepsilon) = \varepsilon$

**Corollary 1.** Let  $a$  be an element in a complete dioid  $\mathcal{D}$ . The mappings  $L_a : x \mapsto a \otimes x$  (left-multiplication by  $a$ ) and  $R_a : x \mapsto x \otimes a$  (right-multiplication by  $a$ ) over  $\mathcal{D}$  are residuated. The residuals are denoted by  $L_a^\sharp(x) = a \backslash x$  (left-division by  $a$ ) and  $R_a^\sharp(x) = x / a$  (right-division by  $a$ ). By definition,  $a \backslash b$  (resp.  $b / a$ ) denotes the greatest solution  $x$  of the inequality  $a \otimes x \leq b$  (resp.  $x \otimes a \leq b$ ).

Next, some calculation rules with left- and right-divisions are recalled.

**Lemma 2** ([1]). Let  $\mathcal{D}$  be a complete dioid. For  $\mathcal{X} \subseteq \mathcal{D}$  and  $a, b, c$  in  $\mathcal{D}$ ,

$$\left( \bigoplus_{x \in \mathcal{X}} x \right) \backslash a = \bigwedge_{x \in \mathcal{X}} x \backslash a \quad \text{and} \quad a / \left( \bigoplus_{x \in \mathcal{X}} x \right) = \bigwedge_{x \in \mathcal{X}} a / x \quad (2.3)$$

$$a \backslash \left( \bigoplus_{x \in \mathcal{X}} x \right) \geq \bigoplus_{x \in \mathcal{X}} a \backslash x \quad \text{and} \quad \left( \bigoplus_{x \in \mathcal{X}} x \right) / a \geq \bigoplus_{x \in \mathcal{X}} x / a \quad (2.4)$$

$$(bc) \backslash a = c \backslash (b \backslash a) \quad \text{and} \quad a / (bc) = (a / c) / b \quad (2.5)$$

**Example 5.** In  $\overline{\mathbb{N}}_{\max}$ ,  $a \backslash b = b / a$ , as  $\otimes$  is commutative. Besides,

$$a \backslash b = b / a = \begin{cases} \top & \text{if } a = \varepsilon \text{ or } b = \top \\ \varepsilon & \text{if } a > b \\ b - a & \text{if } b \geq a \text{ and } a, b \in \mathbb{N}_0 \end{cases}$$

**Proposition 1.** Let  $f_1$  and  $f_2$  be two residuated mappings from a complete selective dioid  $\mathcal{D}_1$  to a distributive dioid  $\mathcal{D}_2$ . The mapping  $g$  from  $\mathcal{D}_1$  to  $\mathcal{D}_2$  defined by,  $\forall x \in \mathcal{D}_1$ ,  $g(x) = f_1(x) \wedge f_2(x)$ , is residuated.

*Proof.* This proof is based on Th. 3. As  $f_1$  and  $f_2$  are residuated mappings,  $g(\varepsilon) = \varepsilon$ . It remains to check that  $g$  is lower semi-continuous. As  $f_1$  and  $f_2$  are isotone,  $g$  is isotone. Therefore, for all  $\mathcal{X} \subseteq \mathcal{D}_1$ ,

$$g\left(\bigoplus_{x \in \mathcal{X}} x\right) \geq \bigoplus_{x \in \mathcal{X}} g(x)$$

Furthermore, as  $f_1$  and  $f_2$  are lower semi-continuous,

$$\begin{aligned} g\left(\bigoplus_{x \in \mathcal{X}} x\right) &= f_1\left(\bigoplus_{x_1 \in \mathcal{X}} x_1\right) \wedge f_2\left(\bigoplus_{x_2 \in \mathcal{X}} x_2\right) \\ &= \left(\bigoplus_{x_1 \in \mathcal{X}} f_1(x_1)\right) \wedge \left(\bigoplus_{x_2 \in \mathcal{X}} f_2(x_2)\right) \end{aligned}$$

As  $\mathcal{D}_2$  is a distributive dioid,

$$\begin{aligned} g\left(\bigoplus_{x \in \mathcal{X}} x\right) &= \bigoplus_{x_1 \in \mathcal{X}} \left( f_1(x_1) \wedge \left( \bigoplus_{x_2 \in \mathcal{X}} f_2(x_2) \right) \right) \\ &= \bigoplus_{x_1 \in \mathcal{X}} \bigoplus_{x_2 \in \mathcal{X}} (f_1(x_1) \wedge f_2(x_2)) \end{aligned}$$

As  $f_1$  and  $f_2$  are isotone,

$$g\left(\bigoplus_{x \in \mathcal{X}} x\right) \leq \bigoplus_{x_1 \in \mathcal{X}} \bigoplus_{x_2 \in \mathcal{X}} (f_1(x_1 \oplus x_2) \wedge f_2(x_1 \oplus x_2))$$

As  $\mathcal{D}_1$  is a selective dioid,  $x_1 \oplus x_2$  is either equal to  $x_1$  or to  $x_2$ . Therefore,  $x_1 \oplus x_2$  belongs to  $\mathcal{X}$ . Then,

$$\begin{aligned} g\left(\bigoplus_{x \in \mathcal{X}} x\right) &\leq \bigoplus_{x \in \mathcal{X}} (f_1(x) \wedge f_2(x)) \\ &\leq \bigoplus_{x \in \mathcal{X}} g(x) \end{aligned}$$

□

Duality leads to a dual version of Def. 8 and of Th. 3.

**Definition 9** (Upper semi-continuity). *A mapping  $f$  from complete dioid  $\mathcal{D}_1$  to complete dioid  $\mathcal{D}_2$  is said to be upper semi-continuous if*

$$\forall \mathcal{X} \subseteq \mathcal{D}_1, \quad f\left(\bigwedge_{x \in \mathcal{X}} x\right) = \bigwedge_{x \in \mathcal{X}} f(x)$$

The following result gives a very handy characterization of dually residuated mappings when the considered ordered sets are complete dioids.

**Theorem 4** ([1]). *Let  $f : \mathcal{D}_1 \rightarrow \mathcal{D}_2$  with  $\mathcal{D}_1$  and  $\mathcal{D}_2$  complete dioids. The following statements are equivalent:*

1.  $f$  is dually residuated
2.  $f$  is upper semi-continuous and  $f(\top) = \top$

### Kleene Star

**Definition 10** (Kleene star). *Let  $\mathcal{D}$  be a complete dioid. The Kleene star of  $a \in \mathcal{D}$ , denoted  $a^*$ , is defined by*

$$a^* = \bigoplus_{k \in \mathbb{N}_0} a^k \text{ with } a^k = \begin{cases} e & \text{if } k = 0 \\ a \otimes a^{k-1} & \text{otherwise} \end{cases}$$

Some properties of the Kleene star are recalled in the following proposition.

**Proposition 2** ([22]). *In a complete dioid  $\mathcal{D}$ , the following equalities hold for all  $a, b \in \mathcal{D}$ :*

$$(a^*)^* = a^* \tag{2.6}$$

$$a^* a^* = a^* \tag{2.7}$$

$$(a \oplus b)^* = (a^* b)^* a^* \tag{2.8}$$

$$(a^* b)^* = e \oplus (a \oplus b)^* b \tag{2.9}$$

The next theorem plays an essential role in the following to solve implicit inequality of the form  $x \geq ax \oplus b$ .

**Theorem 5** (Kleene star theorem, [1]). *Let  $\mathcal{D}$  be a complete dioid and  $a, b \in \mathcal{D}$ . Then, the inequality  $x \geq ax \oplus b$  admits  $a^* b$  as least solution. Furthermore, this solution achieves equality.*

**Example 6.** *In  $\overline{\mathbb{N}}_{\max}$ ,  $a^*$  is either equal to  $e$  if  $a \in \mathbb{B}$  or to  $\top$  otherwise. Then, the equation  $x = ax \oplus b$  admits  $b$  as least solution if  $b = \varepsilon$  or  $a \in \mathbb{B}$  and  $\top$  otherwise.*

### 2.2.2. Subdioid

The concept of subdioid matches the concept of subrings in standard algebra.

**Definition 11** (Subdioid). *A subset  $\mathcal{S}$  of a dioid  $\mathcal{D}$  is a subdioid of  $\mathcal{D}$  if  $\mathcal{S}$  is closed with respect to  $\oplus, \otimes$  and  $\varepsilon, e \in \mathcal{S}$ .*

**Remark 5.** A subdioid  $\mathcal{S}$  of a dioid  $\mathcal{D}$  is a dioid. Besides, if  $\mathcal{D}$  is commutative (resp. selective), then  $\mathcal{S}$  is commutative (resp. selective). This does not hold for completeness or distributivity. A subdioid  $\mathcal{S}$  of a complete dioid  $\mathcal{D}$  is complete if, and only if,  $\mathcal{S}$  is closed under infinite sums.

**Proposition 3** ([4]). Let  $\mathcal{S}$  be a complete subdioid of a complete dioid  $\mathcal{D}$ . Then, the canonical injection  $\mathfrak{i}$  from  $\mathcal{S}$  to  $\mathcal{D}$  is residuated. Its residual  $\mathfrak{i}^\sharp$ , also denoted  $\text{Pr}_{\mathcal{S}}$ , satisfies the following conditions:

1.  $\text{Pr}_{\mathcal{S}} \circ \text{Pr}_{\mathcal{S}} = \text{Pr}_{\mathcal{S}}$
2.  $\text{Pr}_{\mathcal{S}} \leq \text{Id}_{\mathcal{D}}$
3.  $x = \text{Pr}_{\mathcal{S}}(x) \Leftrightarrow x \in \mathcal{S}$

**Remark 6.** Let  $\mathcal{S}$  be a complete subdioid of a complete dioid  $\mathcal{D}$ . The operations  $\wedge^{\mathcal{S}}$ , left-division  $\backslash_{\mathcal{S}}$ , and right-division  $\not\!/_{\mathcal{S}}$  are defined on  $\mathcal{S}$ , as  $\mathcal{S}$  is a complete dioid. Furthermore,

$$\forall \mathcal{X} \subseteq \mathcal{S}, \quad \bigwedge_{x \in \mathcal{X}}^{\mathcal{S}} x = \text{Pr}_{\mathcal{S}} \left( \bigwedge_{x \in \mathcal{X}} x \right)$$

$$\forall a, b \in \mathcal{S}, \quad b \backslash_{\mathcal{S}} a = \text{Pr}_{\mathcal{S}}(b \backslash a) \quad \text{and} \quad a \not\!/_{\mathcal{S}} b = \text{Pr}_{\mathcal{S}}(a \not\!/_ b)$$

**Example 7.**  $\overline{\mathbb{N}}_{\max}$  is a complete subdioid of the complete dioid  $\overline{\mathbb{R}}_{\max}$ . Then, the canonical injection from  $\overline{\mathbb{N}}_{\max}$  to  $\overline{\mathbb{R}}_{\max}$  is residuated and its residual is defined by

$$\text{Pr}_{\overline{\mathbb{N}}_{\max}}(x) = \lfloor x \rfloor$$

### Rational Closure

**Definition 12** (Rational closure). Let  $\mathcal{D}$  be a complete dioid and let  $\mathcal{E}$  be a subset of  $\mathcal{D}$  such that  $\mathbb{B} \subseteq \mathcal{E}$ . The rational closure of  $\mathcal{E}$ , denoted  $\mathcal{E}^*$ , is the least subset of  $\mathcal{D}$  containing all finite combinations of additions, multiplications, and Kleene stars over  $\mathcal{E}$ . A subset  $\mathcal{E}$  of  $\mathcal{D}$  with  $\mathbb{B} \subseteq \mathcal{E}$  is said to be rationally closed if  $\mathcal{E}^* = \mathcal{E}$ .

**Remark 7.** Let  $\mathcal{D}$  be a complete dioid and let  $\mathcal{E}$  be a subset of  $\mathcal{D}$  such that  $\mathbb{B} \subseteq \mathcal{E}$ . The rational closure of  $\mathcal{E}$ , denoted  $\mathcal{E}^*$ , is a subdioid of  $\mathcal{D}$ . Dioid  $\mathcal{E}^*$  might not be complete, but  $\mathcal{E}^*$  is stable with respect to the Kleene star. Furthermore,  $\mathcal{E}^*$  is rationally closed.

**Example 8.** In the complete dioid  $\overline{\mathbb{R}}_{\max}$ , the rational closure of  $\{\varepsilon, e, 1\}$  is the subdioid  $\overline{\mathbb{N}}_{\max}$ .

**Lemma 3.** Let  $\mathcal{D}$  be a complete dioid and  $a, b, c \in \mathcal{D}$ . If  $abdc = badc$  for all  $d \in \{\varepsilon, e, a, b\}^*$ , then

$$(a \oplus b)^* c = a^* b^* c$$

*Proof.* According to (2.8),

$$\begin{aligned} (a \oplus b)^* c &= (a^* b)^* a^* c \\ &= \left( e \oplus \bigoplus_{k \geq 1} (a^* b)^k \right) a^* c \\ &= a^* c \oplus \bigoplus_{k \geq 1} (a^* b)^k a^* c \end{aligned}$$

Due to the assumption  $abdc = badc$  for all  $d \in \{\varepsilon, e, a, b\}^*$ ,

$$\begin{aligned} \forall j \in \mathbb{N}_0, \forall d \in \{\varepsilon, e, a, b\}^*, \quad a^* b^j a^* b d c &= a^* \bigoplus_{k=0}^{+\infty} b^j a^k b d c \\ &= a^* \bigoplus_{k=0}^{+\infty} a^k b^{j+1} d c \\ &= a^* b^{j+1} d c \end{aligned}$$

Therefore,  $\forall k \in \mathbb{N}, (a^* b)^k a^* c = a^* b^k c$ . Then,

$$\begin{aligned} (a \oplus b)^* c &= a^* c \oplus \bigoplus_{k \geq 1} a^* b^k c \\ &= a^* b^* c \end{aligned}$$

□

**Remark 8.** The previous lemma is a minor extension of the classical formula recalled in [22]:

$$(a \oplus b)^* = a^* b^* \text{ if } a \text{ and } b \text{ commute}$$

### 2.3. Morphism

A morphism usually refers to a structure-preserving mapping between two algebraic objects. Next, the notion of morphism is only defined when the domain and the co-domain are dioids.

**Definition 13** ( $\oplus$ -morphism). A mapping  $f$  from dioid  $\mathcal{D}_1$  to dioid  $\mathcal{D}_2$  is a  $\oplus$ -morphism if

$$f(\varepsilon) = \varepsilon \text{ and } \forall a, b \in \mathcal{D}_1, f(a \oplus b) = f(a) \oplus f(b)$$

**Lemma 4.** Let  $f$  be a  $\oplus$ -morphism from dioid  $\mathcal{D}_1$  to dioid  $\mathcal{D}_2$ . Then, mapping  $f$  is isotone.



*Proof.* For  $a, b \in \mathcal{D}_1$ ,

$$\begin{aligned} a \geq b &\Rightarrow a = a \oplus b \\ &\Rightarrow f(a) = f(a \oplus b) = f(a) \oplus f(b) \\ &\Rightarrow f(a) \geq f(b) \end{aligned}$$

□

**Lemma 5.** *Let  $f$  be a residuated mapping from complete dioid  $\mathcal{D}_1$  to complete dioid  $\mathcal{D}_2$ . Then,  $f$  is a  $\oplus$ -morphism.*

*Proof.* This is a direct consequence of Th. 3. □

**Definition 14** ( $\otimes$ -morphism). *A mapping  $f$  from dioid  $\mathcal{D}_1$  to dioid  $\mathcal{D}_2$  is a  $\otimes$ -morphism if*

$$f(e) = e \text{ and } \forall a, b \in \mathcal{D}_1, f(a \otimes b) = f(a) \otimes f(b)$$

**Definition 15** (Homomorphism). *A mapping  $f$  from dioid  $\mathcal{D}_1$  to dioid  $\mathcal{D}_2$  is a homomorphism if it is both a  $\oplus$ -morphism and a  $\otimes$ -morphism.*

**Definition 16** (Isomorphism). *A mapping  $f$  from dioid  $\mathcal{D}_1$  to dioid  $\mathcal{D}_2$  is an isomorphism if it is a bijective homomorphism. If there exists an isomorphism from dioid  $\mathcal{D}_1$  to dioid  $\mathcal{D}_2$ , then dioids  $\mathcal{D}_1$  and  $\mathcal{D}_2$  are said to be isomorphic.*

**Lemma 6.** *Let  $f$  be an isomorphism from dioid  $\mathcal{D}_1$  to dioid  $\mathcal{D}_2$ . Then,  $f^{-1}$  is an isomorphism from dioid  $\mathcal{D}_2$  to dioid  $\mathcal{D}_1$ .*

*Proof.* Mapping  $f^{-1}$  is bijective. It remains to check that  $f^{-1}$  is a homomorphism. We only check the behavior of  $f^{-1}$  with respect to  $\oplus$ , as the result concerning  $\otimes$  is obtained in a similar manner. First, as  $f(\varepsilon) = \varepsilon$ ,

$$f^{-1}(\varepsilon) = f^{-1} \circ f(\varepsilon) = \varepsilon$$

Second, let  $a_1, b_1 \in \mathcal{D}_1$  and  $a_2, b_2 \in \mathcal{D}_2$  such that  $a_1 = f^{-1}(a_2)$  and  $b_1 = f^{-1}(b_2)$ . Then,

$$\begin{aligned} f^{-1}(a_2 \oplus b_2) &= f^{-1}(f(a_1) \oplus f(b_1)) \\ &= f^{-1}(f(a_1 \oplus b_1)) \\ &= a_1 \oplus b_1 \\ &= f^{-1}(a_2) \oplus f^{-1}(b_2) \end{aligned}$$

□

**Lemma 7.** *Let  $f$  be an isomorphism from dioid  $\mathcal{D}_1$  to dioid  $\mathcal{D}_2$ . Then,  $f$  is residuated and its residual  $f^\#$  is  $f^{-1}$ .*

*Proof.* Mappings  $f$  and  $f^{-1}$  are isotone. Besides,  $f \circ f^{-1} \leq \text{Id}_{\mathcal{D}_2}$  and  $f^{-1} \circ f \geq \text{Id}_{\mathcal{D}_1}$ . Therefore, according to Th. 1,  $f$  is residuated and its residual is  $f^{-1}$ . □

### 2.3.1. Dioid of $\oplus$ -Morphisms

The set of mappings over a dioid  $\mathcal{D}$  is endowed with a binary operation  $\oplus$  induced by the binary operation  $\oplus$  over the dioid  $\mathcal{D}$  as mentioned in Rem. 3. Formally,

$$\forall x \in \mathcal{D}, \quad (f_1 \oplus f_2)(x) = f_1(x) \oplus f_2(x)$$

Another binary operation  $\otimes$  is defined as the composition  $\circ$  of mappings. Next, the algebraic structure (with respect to these operations) of particular classes of mappings over dioid  $\mathcal{D}$  is investigated.

**Proposition 4** ([32]). *The set of  $\oplus$ -morphisms over a dioid  $\mathcal{D}$ , denoted  $E_{\mathcal{D}}$ , endowed with the binary operations  $\oplus$  and  $\otimes$  is a dioid. Its zero element  $\varepsilon$  is defined by,  $\forall x \in \mathcal{D}$ ,  $\varepsilon(x) = \varepsilon$ . Its unit element  $e$  is defined by,  $\forall x \in \mathcal{D}$ ,  $e(x) = x$ .*

An interesting problem is to determine whether the dioid  $E_{\mathcal{D}}$  is complete. A necessary condition is to consider a complete dioid  $\mathcal{D}$ . However, the completeness of  $\mathcal{D}$  is not sufficient to ensure the completeness of  $E_{\mathcal{D}}$  as shown in the following example.

**Example 9.** *Let  $f_n$  with  $n \in \mathbb{N}_0$  denote the  $\oplus$ -morphism over the complete dioid  $\overline{\mathbb{N}}_{\max}$  defined by*

$$f_n(x) = \begin{cases} \varepsilon & \text{if } x = \varepsilon \\ n & \text{if } x \in \mathbb{N}_0 \\ \top & \text{if } x = \top \end{cases}$$

Then,

$$\begin{aligned} \left( f_0 \otimes \left( \bigoplus_{n \in \mathbb{N}_0} f_n \right) \right) (e) &= f_0(\top) = \top \\ \left( \bigoplus_{n \in \mathbb{N}_0} (f_0 \otimes f_n) \right) (e) &= \bigoplus_{n \in \mathbb{N}_0} f_0(n) = e \end{aligned}$$

Therefore, right-distributivity cannot be extended to infinite sums. Hence, the dioid  $E_{\mathcal{D}}$  with  $\mathcal{D} = \overline{\mathbb{N}}_{\max}$  is not complete.

**Proposition 5** ([7]). *The set of residuated mappings over a complete dioid  $\mathcal{D}$ , denoted  $\mathcal{F}_{\mathcal{D}}$ , endowed with the previously defined binary operations  $\oplus$  and  $\otimes$  is a complete dioid.*

*Proof.* First, we show that  $\mathcal{F}_{\mathcal{D}}$  is a subdioid of  $E_{\mathcal{D}}$ . According to Lem. 5,  $\mathcal{F}_{\mathcal{D}}$  is a subset of  $E_{\mathcal{D}}$ . Furthermore, a direct consequence of Th. 3 is that the set of residuated mappings coincides

with the set of lower semi-continuous  $\oplus$ -morphisms. Obviously,  $\varepsilon$  and  $e$  are lower semi-continuous. It remains to check that  $\mathcal{F}_{\mathcal{D}}$  is closed with respect to  $\oplus$  and  $\otimes$ . For  $f_1, f_2 \in \mathcal{F}_{\mathcal{D}}$  and  $\mathcal{X} \subseteq \mathcal{D}$ ,

$$\begin{aligned} (f_1 \oplus f_2) \left( \bigoplus_{x \in \mathcal{X}} x \right) &= f_1 \left( \bigoplus_{x \in \mathcal{X}} x \right) \oplus f_2 \left( \bigoplus_{x \in \mathcal{X}} x \right) \\ &= \bigoplus_{x \in \mathcal{X}} f_1(x) \oplus \bigoplus_{x \in \mathcal{X}} f_2(x) \\ &= \bigoplus_{x \in \mathcal{X}} (f_1 \oplus f_2)(x) \end{aligned}$$

$$\begin{aligned} (f_1 \otimes f_2) \left( \bigoplus_{x \in \mathcal{X}} x \right) &= f_1 \left( f_2 \left( \bigoplus_{x \in \mathcal{X}} x \right) \right) \\ &= f_1 \left( \bigoplus_{x \in \mathcal{X}} f_2(x) \right) \text{ since } f_2 \text{ is residuated} \\ &= \bigoplus_{x \in \mathcal{X}} (f_1 \otimes f_2)(x) \text{ since } f_1 \text{ is residuated} \end{aligned}$$

Hence, mappings  $f_1 \oplus f_2$  and  $f_1 \otimes f_2$  are lower semi-continuous. Therefore,  $\mathcal{F}_{\mathcal{D}}$  is a subdioid of  $\mathbb{E}_{\mathcal{D}}$ .

Next, we show that the dioid  $\mathcal{F}_{\mathcal{D}}$  is complete. Consider  $\mathcal{H} \subseteq \mathcal{F}_{\mathcal{D}}$  and  $f = \bigoplus_{h \in \mathcal{H}} h$ . As  $\mathcal{D}$  is complete,  $f$  is a mapping from  $\mathcal{D}$  to  $\mathcal{D}$ . Furthermore,

$$\begin{aligned} f(\varepsilon) &= \bigoplus_{h \in \mathcal{H}} h(\varepsilon) = \varepsilon \\ \forall \mathcal{X} \subseteq \mathcal{D}, \quad f \left( \bigoplus_{x \in \mathcal{X}} x \right) &= \bigoplus_{h \in \mathcal{H}} \bigoplus_{x \in \mathcal{X}} h(x) = \bigoplus_{x \in \mathcal{X}} f(x) \end{aligned}$$

Therefore,  $\mathcal{F}_{\mathcal{D}}$  is closed for infinite sums. It remains to show that distributivity extends to infinite sums. For left-distributivity, it comes directly from the definition of operations  $\oplus$  and  $\otimes$ .

$$\begin{aligned} \forall g \in \mathcal{F}_{\mathcal{D}}, \forall x \in \mathcal{D}, \quad \left( \left( \bigoplus_{h \in \mathcal{H}} h \right) \otimes g \right) (x) &= \bigoplus_{h \in \mathcal{H}} h(g(x)) \\ &= \left( \bigoplus_{h \in \mathcal{H}} (h \otimes g) \right) (x) \end{aligned}$$

For right-distributivity, due to lower semi-continuity,

$$\begin{aligned} \forall g \in \mathcal{F}_{\mathcal{D}}, \forall x \in \mathcal{D}, \quad \left( g \otimes \left( \bigoplus_{h \in \mathcal{H}} h \right) \right) (x) &= g \left( \bigoplus_{h \in \mathcal{H}} h(x) \right) \\ &= \left( \bigoplus_{h \in \mathcal{H}} (g \otimes h) \right) (x) \end{aligned}$$

□

The next step is to determine whether  $\mathcal{F}_{\mathcal{D}}$  is distributive. This problem is not solved in the general case. As  $\mathcal{F}_{\mathcal{D}}$  is a complete dioid, the operation  $\wedge$  is defined. But, for  $\mathcal{H} \subseteq \mathcal{F}_{\mathcal{D}}$ , the calculation of  $\bigwedge_{h \in \mathcal{H}} h$  might not be obvious. Of course,

$$\forall x \in \mathcal{D}, \quad \left( \bigwedge_{h \in \mathcal{H}} h \right) (x) \leq \bigwedge_{h \in \mathcal{H}} h(x)$$

However, the mapping  $g$  from  $\mathcal{D}$  to  $\mathcal{D}$  defined by  $g(x) = \bigwedge_{h \in \mathcal{H}} h(x)$  may not be residuated. A particular case has already been investigated in Prop. 1. If  $\mathcal{D}$  is a complete selective dioid and  $\mathcal{H}$  is a finite subset of  $\mathcal{F}_{\mathcal{D}}$ ,

$$\forall x \in \mathcal{D}, \quad \left( \bigwedge_{h \in \mathcal{H}} h \right) (x) = \bigwedge_{h \in \mathcal{H}} h(x)$$

However, it is not sure that the equality still holds when  $\mathcal{H}$  is not finite. This problem is addressed for the particular case  $\mathcal{D} = \overline{\mathbb{N}}_{\max}$  in § 3.

## 2.4. Matrix Dioid

In this section, some facts on matrices with entries in a dioid are recalled. By analogy with standard linear algebra, the operations  $\oplus$  and  $\otimes$  are extended to matrices with entries in a dioid  $\mathcal{D}$ .

$$\forall A, B \in \mathcal{D}^{n \times p}, \quad (A \oplus B)_{ij} = A_{ij} \oplus B_{ij}$$

$$\forall A \in \mathcal{D}^{n \times p}, \forall B \in \mathcal{D}^{p \times q}, \quad (A \otimes B)_{ij} = \bigoplus_{k=1}^p A_{ik} B_{kj}$$

Besides, if the dioid  $\mathcal{D}$  is complete, the operations  $\wedge$ ,  $\bigvee$ , and  $\bigoplus$  are also extended to matrices.

$$\begin{aligned} \forall A, B \in \mathcal{D}^{n \times p}, \quad (A \wedge B)_{ij} &= A_{ij} \wedge B_{ij} \\ \forall A \in \mathcal{D}^{n \times q}, \forall B \in \mathcal{D}^{n \times p}, \quad (A \bigvee B)_{ij} &= \bigvee_{k=1}^n A_{ki} \bigvee B_{kj} \\ \forall A \in \mathcal{D}^{n \times p}, \forall B \in \mathcal{D}^{q \times p}, \quad (B \bigoplus A)_{ij} &= \bigoplus_{k=1}^p B_{ik} \bigoplus A_{jk} \end{aligned}$$

The order  $\leq$  induced by operation  $\oplus$  corresponds to the standard order for matrices with entries in an ordered set.

$$A \leq B \Leftrightarrow \forall i, j \quad A_{ij} \leq B_{ij}$$

According to this order,  $A \oplus B$  (resp.  $A \wedge B$ ) is the least upper bound (resp. greatest lower bound) of  $\{A, B\}$  and  $A \bigvee B$  (resp.  $B \bigoplus A$ ) corresponds to the greatest solution  $X$  of the inequality  $AX \leq B$  (resp.  $XA \leq B$ ).

**Proposition 6** ([8]). *Let  $\mathcal{D}$  be a dioid. The set  $\mathcal{D}^{n \times n}$  endowed with the operations  $\oplus$  and  $\otimes$  is a dioid. Besides, if  $\mathcal{D}$  is complete (resp. distributive), then  $\mathcal{D}^{n \times n}$  is complete (resp. distributive).*

In the matrix dioid  $\mathcal{D}^{n \times n}$ , the zero element  $\varepsilon$  is defined by  $\varepsilon_{ij} = \varepsilon$  for all  $i, j$  and the unit element  $e$  is defined by

$$e_{ij} = \begin{cases} e & \text{if } i = j \\ \varepsilon & \text{otherwise} \end{cases}$$

If  $\mathcal{D}^{n \times n}$  is complete, then  $\top$  is defined by  $\top_{ij} = \top$  for all  $i, j$ . Dioid  $\mathcal{D}^{n \times n}$  inherits neither commutativity nor selectivity from dioid  $\mathcal{D}$ .

**Remark 9.** *In Th. 5, if  $\alpha$  or  $b$  are not square matrices, it is still possible to extend  $\alpha$ ,  $\alpha$ , and  $b$  with  $\varepsilon$ -rows and  $\varepsilon$ -columns to come down to square matrices. Therefore, the least solution of the matrix inequality  $\alpha \geq \alpha x \oplus b$  is  $\alpha^* b$ .*

**Lemma 8.** *Let  $\mathcal{S}$  be a subdioid of dioid  $\mathcal{D}$ . The set  $\mathcal{S}^{n \times n}$  is a subdioid of dioid  $\mathcal{D}^{n \times n}$ .*

*Proof.* The set  $\mathcal{S}^{n \times n}$  contains the zero element and the unit element of  $\mathcal{D}^{n \times n}$ . Furthermore,  $\mathcal{S}^{n \times n}$  is closed with respect to  $\oplus$  and  $\otimes$ .  $\square$

**Lemma 9.** *If dioids  $\mathcal{D}_1$  and  $\mathcal{D}_2$  are isomorphic, then dioids  $\mathcal{D}_1^{n \times n}$  and  $\mathcal{D}_2^{n \times n}$  are isomorphic.*

*Proof.* There exists an isomorphism  $\phi$  from  $\mathcal{D}_1$  to  $\mathcal{D}_2$ . Then,  $\Phi$  from  $\mathcal{D}_1^{n \times n}$  to  $\mathcal{D}_2^{n \times n}$  defined by

$$\forall A \in \mathcal{D}_1^{n \times n}, \quad (\Phi(A))_{ij} = \phi(A_{ij})$$

is an isomorphism.  $\square$

The next results focus on Kleene star of matrices and rationality.

**Lemma 10** ([1, 8]). *Let  $\mathcal{D}$  be a complete dioid and  $n_1, n_2 \in \mathbb{N}$ . Consider matrices  $A \in \mathcal{D}^{n_1 \times n_1}$ ,  $B \in \mathcal{D}^{n_1 \times n_2}$ ,  $C \in \mathcal{D}^{n_2 \times n_1}$ , and  $D \in \mathcal{D}^{n_2 \times n_2}$ . Then,*

$$\begin{pmatrix} A & B \\ C & D \end{pmatrix}^* = \begin{pmatrix} (A \oplus BD^*C)^* & A^*B(CA^*B \oplus D)^* \\ (CA^*B \oplus D)^*CA^* & (CA^*B \oplus D)^* \end{pmatrix}$$

**Theorem 6** ([8]). *Let  $\mathcal{D}$  be a complete dioid and let  $\mathcal{E}$  be a subset of  $\mathcal{D}$  such that  $\mathbb{B} \subseteq \mathcal{E}$ . The subdioids  $(\mathcal{E}^{n \times n})^*$  and  $(\mathcal{E}^*)^{n \times n}$  are identical.*

### 2.4.1. Rational Representation

Next, a particular representation, namely the  $(B, C)$ -representation, for a class of matrices is introduced. Later on, this representation appears to play a major role in system theory.

**Definition 17** ( $(B, C)$ -representation). *Let  $\mathcal{D}$  be a complete dioid and let  $\mathcal{E}$  be a subset of  $\mathcal{D}$  such that  $\mathbb{B} \subseteq \mathcal{E}$ . An element  $X \in \mathcal{D}^{m \times p}$  admits a  $(B, C)$ -representation with respect to  $\mathcal{E}$  if there exist  $n \in \mathbb{N}$ ,  $C \in \mathbb{B}^{m \times n}$ ,  $A \in \mathcal{E}^{n \times n}$ , and  $B \in \mathbb{B}^{n \times p}$  such that  $X = CA^*B$ .*

**Theorem 7** ([8]). *Let  $\mathcal{D}$  be a complete dioid and let  $\mathcal{E}$  be a subset of  $\mathcal{D}$  such that  $\mathbb{B} \subseteq \mathcal{E}$ . The dioid  $\mathcal{E}^*$  coincides with the set of elements  $x \in \mathcal{D}$  admitting a  $(B, C)$ -representation with respect to  $\mathcal{E}$ .*

**Proposition 7.** *Let  $\mathcal{D}$  be a complete dioid and let  $\mathcal{E}$  be a subset of  $\mathcal{D}$  such that  $\mathbb{B} \subseteq \mathcal{E}$ . For  $X \in \mathcal{D}^{m \times p}$ , the following statements are equivalent:*

1.  $X$  admits a  $(B, C)$ -representation
2. each entry of  $X$  admits a  $(B, C)$ -representation

*Proof.* 1  $\Rightarrow$  2:  $X$  admits a  $(B, C)$ -representation, then there exist  $n \in \mathbb{N}$ ,  $C \in \mathbb{B}^{m \times n}$ ,  $A \in \mathcal{E}^{n \times n}$ , and  $B \in \mathbb{B}^{n \times p}$  such that  $X = CA^*B$ . Consequently,  $X_{ij} = C_i A^* B_j$  where  $C_i$  is the  $i$ -th row of  $C$  and  $B_j$  the  $j$ -th column of  $B$ . Then,  $X_{ij}$  admits a  $(B, C)$ -representation.

2  $\Rightarrow$  1:  $X_{ij}$  admits a  $(B, C)$ -representation. There exist  $n_{ij} \in \mathbb{N}$ ,  $C_{ij} \in \mathbb{B}^{1 \times n_{ij}}$ ,  $A \in \mathcal{E}^{n_{ij} \times n_{ij}}$ , and  $B \in \mathbb{B}^{n_{ij} \times 1}$  such that  $X_{ij} = C_{ij} A^* B_{ij}$ . Then,  $X = CA^*B$  with

$$\begin{aligned} A &= \text{diag}(A_{11}, \dots, A_{1p}, \dots, A_{m1}, \dots, A_{mp}) \\ C &= \text{diag}([C_{11} \dots C_{1p}], \dots, [C_{m1} \dots C_{mp}]) \\ B &= \begin{pmatrix} \text{diag}(B_{11}, \dots, B_{1p}) \\ \vdots \\ \text{diag}(B_{m1}, \dots, B_{mp}) \end{pmatrix} \end{aligned}$$

Hence,  $X$  admits a  $(B, C)$ -representation. □

## 2.5. Dioid of Formal Power Series

Formal power series with coefficients in a dioid  $\mathcal{D}$  provide an elegant way to manipulate mappings from  $\mathbb{Z}^p$  (with  $p \in \mathbb{N}$ ) to  $\mathcal{D}$ . A complete survey on formal power series with coefficients in a dioid is available in [1].

**Definition 18** (Formal power series). *A formal power series in  $p$  commutative variables with coefficients in a complete dioid  $\mathcal{D}$  is a mapping from  $\mathbb{Z}^p$  to  $\mathcal{D}$ . A compact notation for a formal power series  $s$  is*

$$s = \bigoplus_{k \in \mathbb{Z}^p} s(k) z_1^{k_1} \dots z_p^{k_p} \text{ where } k = (k_1, \dots, k_p)$$

The set of formal power series in  $p$  commutative variables  $z_1, \dots, z_p$  with coefficients in  $\mathcal{D}$  is denoted  $\mathcal{D}[[z_1, \dots, z_p]]$ .

The support of a formal power series  $s$ , denoted  $\text{supp}(s)$ , is defined by

$$\text{supp}(s) = \{k \in \mathbb{Z}^p \mid s(k) \neq \varepsilon\}$$

The valuation of a formal power series  $s$ , denoted  $\text{val}(s)$ , is the greatest lower bound of its support. The degree of a formal power series  $s$ , denoted  $\text{deg}(s)$ , is the least upper bound of its support.

A polynomial (resp. monomial) is a formal power series with a finite support (resp. with an empty support or a support reduced to a singleton).

Usually, only the values on the support are made explicit in the writing of a formal power series. The set  $\mathcal{D}[[z_1, \dots, z_p]]$  is endowed with the binary operation  $\oplus$  already mentioned in Rem. 3, i.e.,

$$\forall k \in \mathbb{Z}^p, \quad (s_1 \oplus s_2)(k) = s_1(k) \oplus s_2(k)$$

Another operation  $\otimes$  is defined as the Cauchy product.

$$\forall k \in \mathbb{Z}^p, \quad (s_1 \otimes s_2)(k) = \bigoplus_{j \in \mathbb{Z}^p} s_1(j) s_2(k - j)$$

**Proposition 8** ([1]). *Let  $\mathcal{D}$  be a complete dioid. The set  $\mathcal{D}[[z_1, \dots, z_p]]$  endowed with the operations  $\oplus$  and  $\otimes$  defined before is a complete dioid. If  $\mathcal{D}$  is commutative (resp. distributive), then  $\mathcal{D}[[z_1, \dots, z_p]]$  is commutative (resp. distributive).*

The Cauchy product justifies the restriction to complete dioids as shown in the next example.

**Example 10.** Let  $f_1$  and  $f_2$  be two mappings from  $\mathbb{Z}$  to the non-complete dioid  $\mathbb{R}_{\max}$  defined by

$$\forall k \in \mathbb{Z}, \quad f_1(k) = \max(k, 0) \text{ and } f_2(k) = e$$

Then,

$$\begin{aligned} (f_1 \otimes f_2)(0) &= \bigoplus_{k \in \mathbb{Z}} (f_1(k) \otimes f_2(-k)) \\ &= \bigoplus_{k \in \mathbb{N}_0} k \\ &= +\infty \notin \mathbb{R}_{\max} \end{aligned}$$

Therefore, the Cauchy product may not be defined when the dioid of coefficients is not complete.

The zero element  $\varepsilon$  of  $\mathcal{D}[[z_1, \dots, z_p]]$  is defined by  $\varepsilon(k) = \varepsilon$  for all  $k \in \mathbb{Z}^p$ . The unit element  $e$  of  $\mathcal{D}[[z_1, \dots, z_p]]$  is defined by

$$e(k) = \begin{cases} e & \text{if } k = (0, \dots, 0) \\ \varepsilon & \text{otherwise} \end{cases}$$

As  $\mathcal{D}[[z_1, \dots, z_p]]$  is a complete dioid, operation  $\wedge$  exists for formal power series and is defined by

$$\forall k \in \mathbb{Z}^p, \quad (s_1 \wedge s_2)(k) = s_1(k) \wedge s_2(k)$$

The top element  $\top$  of  $\mathcal{D}[[z_1, \dots, z_p]]$  is defined by  $\top(k) = \top$  for all  $k \in \mathbb{Z}^p$ . Besides, for all  $k \in \mathbb{Z}^p$ , left-division and right-division are defined by

$$(s_1 \backslash s_2)(k) = \bigwedge_{j \in \mathbb{Z}^p} s_1(j) \backslash s_2(k+j) \tag{2.10}$$

$$(s_2 / s_1)(k) = \bigwedge_{j \in \mathbb{Z}^p} s_2(k+j) / s_1(j) \tag{2.11}$$

**Lemma 11.** If complete dioids  $\mathcal{D}_1$  and  $\mathcal{D}_2$  are isomorphic, then dioids  $\mathcal{D}_1[[z_1, \dots, z_p]]$  and  $\mathcal{D}_2[[z_1, \dots, z_p]]$  are isomorphic.

*Proof.* There exists an isomorphism  $\phi$  from  $\mathcal{D}_1$  to  $\mathcal{D}_2$ . Then,  $\Phi$  from  $\mathcal{D}_1[[z_1, \dots, z_p]]$  to  $\mathcal{D}_2[[z_1, \dots, z_p]]$  defined by

$$\forall s \in \mathcal{D}_1[[z_1, \dots, z_p]], \quad \Phi(s) = \phi \circ s$$

is an isomorphism. □



**Lemma 12.** Let  $\mathcal{S}$  be a complete subdioid of a complete dioid  $\mathcal{D}$ . The set  $\mathcal{S}[[z_1, \dots, z_p]]$  is a complete subdioid of  $\mathcal{D}[[z_1, \dots, z_p]]$ .

*Proof.* The set  $\mathcal{S}[[z_1, \dots, z_p]]$  contains the zero element and the unit element of  $\mathcal{D}[[z_1, \dots, z_p]]$ . Furthermore,  $\mathcal{S}[[z_1, \dots, z_p]]$  is closed under infinite sums and with respect to  $\otimes$ .  $\square$

**Example 11** (Dioid  $\overline{\mathbb{N}}_{\max}[[\gamma]]$ ). The dioid  $\overline{\mathbb{N}}_{\max}[[\gamma]]$  is the dioid of formal power series in  $\gamma$  with coefficients in the complete dioid  $\overline{\mathbb{N}}_{\max}$  equal to  $\varepsilon$  over  $\{k \in \mathbb{Z} | k < 0\}$ . The series  $s = 3 \oplus 7\gamma^5$  belongs to  $\overline{\mathbb{N}}_{\max}[[\gamma]]$  and corresponds to the mapping from  $\mathbb{Z}$  to  $\overline{\mathbb{N}}_{\max}$  defined by

$$s(k) = \begin{cases} 3 & \text{if } k = 0 \\ 7 & \text{if } k = 5 \\ \varepsilon & \text{otherwise} \end{cases}$$

Furthermore,  $\text{supp}(s) = \{0, 5\}$ . Then,  $s$  is a polynomial,  $\text{val}(s) = 0$ , and  $\text{deg}(s) = 5$ .

### 2.5.1. Dioid of Isotone Formal Power Series

Let  $\mathcal{D}$  be a complete dioid. In the following, we only consider formal power series in a single variable  $\gamma$  with coefficients in  $\mathcal{D}$ . Sets  $\mathbb{Z}$  and  $\mathcal{D}$  are ordered. Then, a formal power series  $s \in \mathcal{D}[[\gamma]]$  is isotone if

$$\forall k, l \in \mathbb{Z}, \quad k \geq l \Rightarrow s(k) \geq s(l)$$

The following lemma gives a simple characterization of isotone formal power series.

**Lemma 13.** Let  $s$  in  $\mathcal{D}[[\gamma]]$ . Series  $s$  is isotone  $\Leftrightarrow s = \gamma^*s$ .

*Proof.*  $\Rightarrow$  As  $\gamma^* \geq e$ ,  $\gamma^*s \geq s$ . Conversely, as  $s$  is isotone,  $\forall k \in \mathbb{Z}$ ,  $s(k+1) \geq s(k)$ . Thus,  $s \geq \gamma s$ . This leads to  $s \geq \gamma^*s$ . Hence,  $s = \gamma^*s$ .  
 $\Rightarrow s = \gamma^*s$  implies

$$\forall k \in \mathbb{Z}, \quad s(k) = \bigoplus_{j \in \mathbb{N}_0} s(k-j)$$

Therefore,

$$\forall k, l \in \mathbb{Z}, \quad k \geq l \Rightarrow s(k) \geq s(l)$$

Hence,  $s$  is an isotone formal power series.  $\square$

Lem. 13 allows us to easily determine the algebraic structure of the set of isotone formal power series.

**Proposition 9.** *Let  $\mathcal{D}$  be a complete dioid. The set of isotone formal power series in  $\mathcal{D}[[\gamma]]$  endowed with the operations  $\oplus$  and  $\otimes$  is a complete dioid, denoted  $\mathcal{D}_\gamma[[\gamma]]$ . Furthermore, if  $\mathcal{D}$  is commutative,  $\mathcal{D}_\gamma[[\gamma]]$  is commutative.*

*Proof.* Let  $s_1$  and  $s_2$  be two isotone formal power series in  $\mathcal{D}[[\gamma]]$ .

$$\begin{aligned} s_1 \oplus s_2 &= \gamma^* s_1 \oplus \gamma^* s_2 = \gamma^* (s_1 \oplus s_2) \\ s_1 \otimes s_2 &= (\gamma^* s_1) s_2 = \gamma^* (s_1 \otimes s_2) \end{aligned}$$

Then,  $\mathcal{D}_\gamma[[\gamma]]$  is closed with respect to  $\oplus$  and  $\otimes$ .

As  $\mathcal{D}_\gamma[[\gamma]]$  is included in  $\mathcal{D}[[\gamma]]$ , the operation  $\oplus$  is associative, commutative, and idempotent, and the operation  $\otimes$  is associative and distributive on both sides with respect to  $\oplus$ . Furthermore, the zero element of  $\mathcal{D}[[\gamma]]$  is isotone: it is the neutral element  $\varepsilon$  for  $\oplus$  in  $\mathcal{D}_\gamma[[\gamma]]$ . Consequently,  $\varepsilon$  is absorbing for  $\otimes$ . For  $s \in \mathcal{D}_\gamma[[\gamma]]$ ,  $s = \gamma^* s$  and, obviously,  $s = s\gamma^*$ . Therefore,  $\gamma^*$  is the neutral element  $e$  for  $\otimes$  in  $\mathcal{D}_\gamma[[\gamma]]$ . Thus,  $\mathcal{D}_\gamma[[\gamma]]$  is a dioid included in  $\mathcal{D}[[\gamma]]$ , but not a subdioid of  $\mathcal{D}[[\gamma]]$ .

$\mathcal{D}_\gamma[[\gamma]]$  is stable under infinite sums and distributivity extends to infinite sums. Hence,  $\mathcal{D}_\gamma[[\gamma]]$  is a complete dioid.

Clearly, if  $\mathcal{D}$  is commutative,  $\mathcal{D}[[\gamma]]$  is commutative. Hence, if  $\mathcal{D}$  is commutative,  $\mathcal{D}_\gamma[[\gamma]]$  is commutative.  $\square$

As  $\mathcal{D}_\gamma[[\gamma]]$  is a complete dioid, the operation  $\wedge_\gamma$ ,  $\bowtie_\gamma$ , and  $\not\bowtie_\gamma$  are defined on  $\mathcal{D}_\gamma[[\gamma]]$ . Furthermore,  $s_1 \wedge_\gamma s_2$ ,  $s_1 \bowtie_\gamma s_2$ , and  $s_2 \not\bowtie_\gamma s_1$  correspond respectively to the greatest isotone formal power series less than or equal to  $s_1 \wedge s_2$ ,  $s_1 \bowtie s_2$ , and  $s_2 \not\bowtie s_1$ . It is easy to check that these series are isotone. Thus,  $s_1 \wedge_\gamma s_2 = s_1 \wedge s_2$ ,  $s_1 \bowtie_\gamma s_2 = s_1 \bowtie s_2$ , and  $s_2 \not\bowtie_\gamma s_1 = s_2 \not\bowtie s_1$ .

**Lemma 14.** *Let  $\mathcal{D}$  a complete dioid. If  $\mathcal{D}$  is distributive,  $\mathcal{D}_\gamma[[\gamma]]$  is distributive.*

*Proof.* As  $\mathcal{D}$  is distributive,  $\mathcal{D}[[\gamma]]$  is distributive. As  $\wedge$  and  $\oplus$  are the same operations in  $\mathcal{D}[[\gamma]]$  and in  $\mathcal{D}_\gamma[[\gamma]]$ ,  $\mathcal{D}_\gamma[[\gamma]]$  is distributive.  $\square$

## 2.6. Quotient Dioid

By analogy with quotient rings (e.g.,  $\mathbb{Z}/n\mathbb{Z}$  with  $n \in \mathbb{N}$ ), quotient dioids are defined. More details on quotient dioids can be found in [11].

**Definition 19** (Congruence relation). *A congruence relation on a dioid  $\mathcal{D}$  is an equivalence relation  $\mathcal{R}$  on  $\mathcal{D}$  such that*

$$\forall c \in \mathcal{D}, \quad a\mathcal{R}b \Rightarrow \begin{cases} (a \oplus c) \mathcal{R} (b \oplus c) \\ ca\mathcal{R}cb \text{ and } ac\mathcal{R}bc \end{cases}$$

**Proposition 10** ([11]). *Let  $\mathcal{D}$  be a dioid. The quotient set of  $\mathcal{D}$  by the congruence relation  $\mathcal{R}$  endowed with*

$$a_{\mathcal{R}} \oplus b_{\mathcal{R}} = (a \oplus b)_{\mathcal{R}} \text{ and } a_{\mathcal{R}} \otimes b_{\mathcal{R}} = (a \otimes b)_{\mathcal{R}}$$

*is a dioid named quotient dioid of  $\mathcal{D}$  by  $\mathcal{R}$  and denoted  $\mathcal{D}_{\mathcal{R}}$ . Besides,  $\mathcal{D}_{\mathcal{R}}$  inherits completeness, commutativity, and selectivity from  $\mathcal{D}$ .*

The zero element  $\varepsilon_{\mathcal{R}}$  (resp. the unit element  $e_{\mathcal{R}}$ ) of  $\mathcal{D}_{\mathcal{R}}$  is the equivalence class of  $\varepsilon$  (resp.  $e$ ).

If a quotient dioid is considered, no distinction is usually made between an equivalence class (an element in  $\mathcal{D}_{\mathcal{R}}$ ) and one of its representatives (an element in  $\mathcal{D}$ ). An element in  $\mathcal{D}$  is associated with its equivalence class. To tackle the inverse problem (*i.e.*, associating an element in  $\mathcal{D}_{\mathcal{R}}$  with an element in  $\mathcal{D}$ ), a canonical representative for an equivalence class is defined. In this section, this question is not addressed in general.

### 2.6.1. Quotient Dioid of a Dioid of Formal Power Series

Quotient dioids of dioids of formal power series play an important role in the following. The notion of support is generalized to quotient dioids of dioids of formal power series.

**Definition 20.** *Let  $\mathcal{D}[[z_1, \dots, z_p]]$  be a dioid of formal power series and let  $\mathcal{R}$  be a congruence relation on  $\mathcal{D}[[z_1, \dots, z_p]]$ . The support of the equivalence class  $s_{\mathcal{R}}$  of a series  $s \in \mathcal{D}[[z_1, \dots, z_p]]$  is defined as*

$$\text{supp}(s_{\mathcal{R}}) = \bigcap_{s \in s_{\mathcal{R}}} \text{supp}(s)$$

*A polynomial (resp. monomial) in  $\mathcal{D}[[z_1, \dots, z_p]]_{\mathcal{R}}$  is an equivalence class with a finite support (resp. an empty support or a support reduced to a singleton).*

### Congruence for the Dioid of Isotone Formal Power Series

Let  $\mathcal{D}$  be a complete dioid. The complete dioid of formal power series in  $\gamma$  with coefficients in  $\mathcal{D}$  is considered. In the following, the congruence relation  $\mathcal{R}$  is defined on  $\mathcal{D}[[\gamma]]$  by

$$a \mathcal{R} b \Leftrightarrow \gamma^* a = \gamma^* b$$

**Lemma 15.** *Dioids  $\mathcal{D}_{\mathcal{R}}[[\gamma]]$  and  $\mathcal{D}_{\gamma}[[\gamma]]$  are isomorphic.*

*Proof.* Let  $\Phi$  be the mapping from  $\mathcal{D}_{\gamma}[[\gamma]]$  to  $\mathcal{D}_{\mathcal{R}}[[\gamma]]$  defined by  $\Phi(s) = s_{\mathcal{R}}$ .

For  $s_1, s_2$  in  $\mathcal{D}_{\gamma}[[\gamma]]$ ,

$$\begin{aligned} \Phi(s_1) = \Phi(s_2) &\Rightarrow \gamma^* s_1 = \gamma^* s_2 \\ &\Rightarrow s_1 = s_2 \end{aligned}$$

Therefore,  $\Phi$  is injective.

For  $S$  in  $\mathcal{D}_{\mathcal{R}}[[\gamma]]$  and  $s \in S$ ,  $\gamma^*s$  belongs to  $S \cap \mathcal{D}_{\gamma}[[\gamma]]$ . Therefore,  $\Phi(\gamma^*s) = S$ . Then,  $\Phi$  is surjective. Mapping  $\Phi$  is a bijection from  $\mathcal{D}_{\gamma}[[\gamma]]$  to  $\mathcal{D}_{\mathcal{R}}[[\gamma]]$ .

Furthermore, for  $s_1, s_2$  in  $\mathcal{D}_{\gamma}[[\gamma]]$ ,

$$\begin{aligned}\Phi(\varepsilon) &= \varepsilon_{\mathcal{R}} \\ \Phi(\gamma^*) &= \gamma_{\mathcal{R}}^* = e_{\mathcal{R}} \\ \Phi(s_1 \oplus s_2) &= s_{1\mathcal{R}} \oplus s_{2\mathcal{R}} = \Phi(s_1) \oplus \Phi(s_2) \\ \Phi(s_1 \otimes s_2) &= s_{1\mathcal{R}} \otimes s_{2\mathcal{R}} = \Phi(s_1) \otimes \Phi(s_2)\end{aligned}$$

Consequently,  $\Phi$  is an isomorphism from  $\mathcal{D}_{\gamma}[[\gamma]]$  to  $\mathcal{D}_{\mathcal{R}}[[\gamma]]$ . □

A series  $s$  in  $\mathcal{D}_{\gamma}[[\gamma]]$  is associated with an element  $S$  in  $\mathcal{D}_{\mathcal{R}}[[\gamma]]$ . Therefore, a representative  $s'$  of  $S$  characterizes  $s$ . This is sometimes written in a slightly ambiguous manner  $s = s'$ . This leads to richer definitions for support, monomials, and polynomials in the dioid  $\mathcal{D}_{\gamma}[[\gamma]]$ .

**Definition 21** ( $\gamma$ -support). *Let  $s$  be a series in  $\mathcal{D}_{\gamma}[[\gamma]]$ . The  $\gamma$ -support of  $s$ , denoted  $\text{supp}_{\gamma}(s)$ , is defined by  $\text{supp}_{\gamma}(s) = \text{supp}(s_{\mathcal{R}})$ .*

The classical definitions of polynomials leads to a single polynomial in  $\mathcal{D}_{\gamma}[[\gamma]]$ , namely  $\varepsilon$ . Therefore, from now on, monomials and polynomials in  $\mathcal{D}_{\gamma}[[\gamma]]$  are defined with respect to the  $\gamma$ -support.

**Definition 22.** *Let  $s$  be a series in  $\mathcal{D}_{\gamma}[[\gamma]]$ . Series  $s$  is a polynomial if its  $\gamma$ -support is finite. Series  $s$  is monomial if its  $\gamma$ -support is either empty or a singleton.*

The greatest lower bounds of  $\text{supp}_{\gamma}(s)$  and  $\text{val}(s)$  coincide. However, the least upper bound of  $\text{supp}_{\gamma}(s)$  might be less than  $\text{deg}(s)$ . Then, the  $\gamma$ -degree of series  $s$ , denoted  $\text{deg}_{\gamma}(s)$ , is defined as the least upper bound of  $\text{supp}_{\gamma}(s)$ . Next, the canonical representatives for a subclass of polynomials in  $\mathcal{D}_{\gamma}[[\gamma]]$  is introduced.

**Definition 23.** *Let  $p$  be a polynomial in  $\mathcal{D}_{\gamma}[[\gamma]]$  fulfilling the condition: there exists  $k \in \mathbb{Z}$  such that  $p(k) = \varepsilon$ . If  $p = \varepsilon$ , its canonical representative is  $\varepsilon$ . Otherwise, the canonical representative of  $p$  is  $\bigoplus_{k \in \text{supp}_{\gamma}(p)} p(k) \gamma^k$ .*

An algorithm to compute the canonical representative of an element in the previous class of polynomials from any representative consists in, first, maximizing the coefficients and, second, deleting the redundant coefficients.

## 2.7. Dioid $\overline{\mathbb{N}}_{\max, \gamma}[[\gamma]]$

The dioid  $\overline{\mathbb{N}}_{\max, \gamma}[[\gamma]]$  plays a major role in the modeling and control of  $(\max, +)$ -linear systems (e.g., [1, 14]). In this chapter, the dioid  $\overline{\mathbb{N}}_{\max, \gamma}[[\gamma]]$  is briefly introduced and the concepts of periodicity, rationality, and realizability are recalled for this dioid. The presented results mainly come from [1, 8, 22].

**Definition 24** (Dioid  $\overline{\mathbb{N}}_{\max, \gamma}[\gamma]$ ). *The distributive dioid  $\overline{\mathbb{N}}_{\max, \gamma}[\gamma]$  is defined as the dioid of isotone formal power series in  $\gamma$  with coefficients in the distributive dioid  $\overline{\mathbb{N}}_{\max}$  equal to  $\varepsilon$  over  $\{k \in \mathbb{Z} \mid k < 0\}$ . Furthermore, as  $\overline{\mathbb{N}}_{\max}$  is commutative,  $\overline{\mathbb{N}}_{\max, \gamma}[\gamma]$  is commutative.*

According to Prop. 9 and Lem. 14, the previous definition is valid. By definition, a series  $s$  in  $\overline{\mathbb{N}}_{\max, \gamma}[\gamma]$  is an isotone mapping from  $\mathbb{Z}$  to  $\overline{\mathbb{N}}_{\max}$  such that  $s(k) = \varepsilon$  for  $k < 0$ .

**Example 12.** *Let  $s = 1\gamma \oplus 4\gamma^3$  be a series in  $\overline{\mathbb{N}}_{\max, \gamma}[\gamma]$ .*

$$s(k) = \begin{cases} \varepsilon & \text{if } k < 1 \\ 1 & \text{if } k = 1, 2 \\ 4 & \text{if } k \geq 3 \end{cases}$$

The  $\gamma$ -support of  $s$  is  $\{1, 3\}$ . Therefore,  $s$  is a polynomial and, according to Def. 23, its canonical representative is  $1\gamma \oplus 4\gamma^3$ . A graphical representation of  $s$  is drawn in Fig. 2.1.

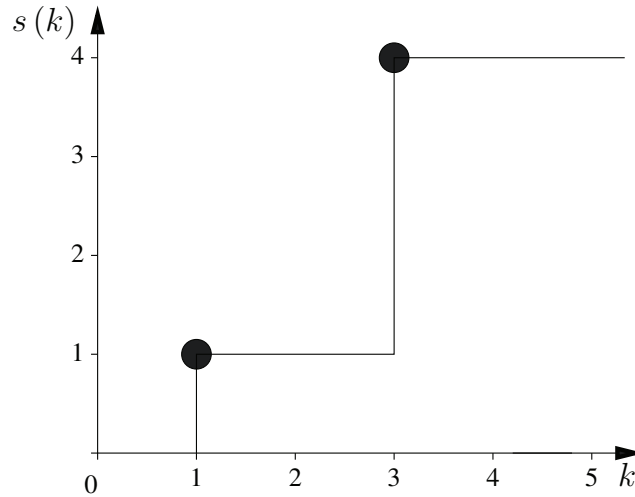

Figure 2.1.: Series  $s = 1\gamma \oplus 4\gamma^3$

### 2.7.1. Periodicity

**Definition 25** (Periodicity). *A series  $s$  in  $\overline{\mathbb{N}}_{\max, \gamma}[\gamma]$  is said to be periodic if there exist two polynomials  $p, q$  in  $\overline{\mathbb{N}}_{\max, \gamma}[\gamma]$ ,  $\tau \in \mathbb{N}_0$ , and  $\nu \in \mathbb{N}$  such that  $s = p \oplus q(\tau\gamma^\nu)^*$ . A matrix with entries in  $\overline{\mathbb{N}}_{\max, \gamma}[\gamma]$  is said to be periodic if all its entries are periodic.*

A canonical representative for periodic series in  $\overline{\mathbb{N}}_{\max, \gamma}[\gamma]$  has been introduced in [22, 23].

**Definition 26** (Throughput). *The throughput of a non-zero periodic series  $s = p \oplus q (\tau\gamma^\nu)^*$  in  $\overline{\mathbb{N}}_{\max, \gamma}[[\gamma]]$ , denoted  $\sigma(s)$ , is defined by*

$$\sigma(s) = \begin{cases} +\infty & \text{if } s \text{ is a polynomial and } \forall k \in \mathbb{Z}, s(k) < \top \\ 0 & \text{if } s \text{ is a polynomial and } \exists k \in \mathbb{Z} | s(k) = \top \\ \frac{\nu}{\tau} & \text{otherwise} \end{cases}$$

**Example 13.** *Let  $s$  be a periodic series in  $\overline{\mathbb{N}}_{\max, \gamma}[[\gamma]]$  with the canonical representative  $3 \oplus 4\gamma^2 \oplus (6\gamma^3 \oplus 8\gamma^4) (3\gamma^2)^*$ . Then,*

$$\forall k \geq 3, \quad s(k+2) = 3s(k)$$

*The transient of  $s$  is given by the polynomial  $p = 3 \oplus 4\gamma^2$ . The pattern of  $s$  is given by the polynomial  $q = 6\gamma^3 \oplus 8\gamma^4$ . Due to the periodicity  $3\gamma^2$ , the pattern  $q$  is repeated (translation of two units to the right and three units to the top). The throughput of  $s$  is*

$$\sigma(s) = \frac{\nu}{\tau} = \frac{2}{3}$$

*A graphical representation of  $s$  is drawn in Fig. 2.2.*

### Calculations with Periodic Series

**Proposition 11** (Sum of periodic series [11, 22]). *Let  $s_1$  and  $s_2$  be two periodic series in  $\overline{\mathbb{N}}_{\max, \gamma}[[\gamma]]$ . Series  $s_1 \oplus s_2$  is periodic. Furthermore, if  $s_1$  and  $s_2$  are different from  $\varepsilon$ , then*

$$\sigma(s_1 \oplus s_2) = \min(\sigma(s_1), \sigma(s_2))$$

**Proposition 12** (Greatest lower bound of periodic series [11]). *Let  $s_1$  and  $s_2$  be two periodic series in  $\overline{\mathbb{N}}_{\max, \gamma}[[\gamma]]$ . Series  $s_1 \wedge s_2$  is periodic. Furthermore, if  $s_1$  and  $s_2$  are different from  $\varepsilon$ , then*

$$\sigma(s_1 \wedge s_2) = \max(\sigma(s_1), \sigma(s_2))$$

**Proposition 13** (Product of periodic series [11, 22]). *Let  $s_1$  and  $s_2$  be two periodic series in  $\overline{\mathbb{N}}_{\max, \gamma}[[\gamma]]$ . Series  $s_1 \otimes s_2$  is periodic. Furthermore, if  $s_1$  and  $s_2$  are different from  $\varepsilon$ , then*

$$\sigma(s_1 \otimes s_2) = \min(\sigma(s_1), \sigma(s_2))$$

**Proposition 14** (Division of periodic series [11]). *Let  $s_1$  and  $s_2$  be two periodic series in  $\overline{\mathbb{N}}_{\max, \gamma}[[\gamma]]$ . Series  $s_1 \setminus s_2$  and  $s_2 \setminus s_1$  are periodic. Furthermore, if  $s_1$  and  $s_2$  are different from  $\varepsilon$ ,*

- $s_1 \setminus s_2 = s_2 \setminus s_1 = \varepsilon$  if  $\sigma(s_1) < \sigma(s_2)$
- $\sigma(s_1 \setminus s_2) = \sigma(s_2 \setminus s_1) = \sigma(s_2)$  otherwise

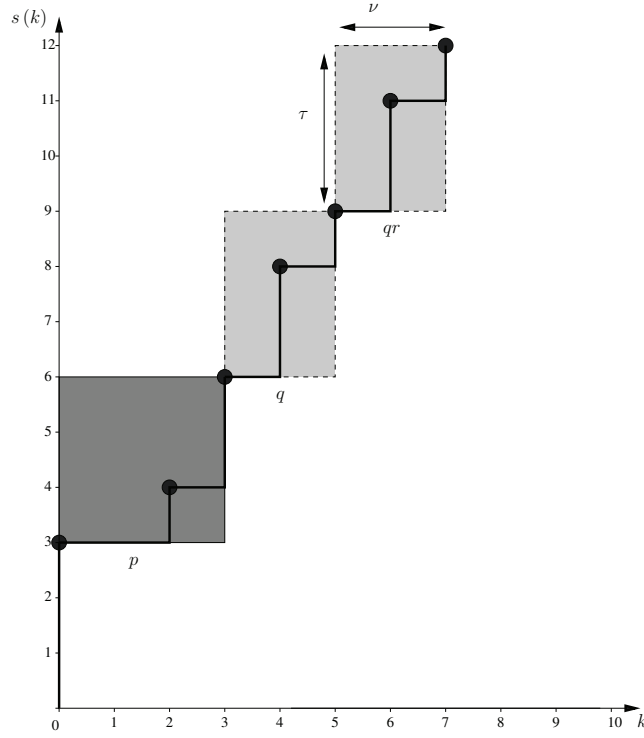
 Figure 2.2.: Series  $s = 3 \oplus 4\gamma^2 \oplus (6\gamma^3 \oplus 8\gamma^4) (3\gamma^2)^*$ 

According to Prop. 11 and Prop. 13, the set of periodic series in  $\overline{\mathbb{N}}_{\max, \gamma}[\gamma]$  is a subdioid of  $\overline{\mathbb{N}}_{\max, \gamma}[\gamma]$ , denoted  $\overline{\mathbb{N}}_{\max, \gamma}^{\text{per}}[\gamma]$ . Moreover, the dioid  $\overline{\mathbb{N}}_{\max, \gamma}^{\text{per}}[\gamma]$  is rationally closed as shown in the next proposition.

**Proposition 15** (Kleene star of periodic series [11, 22]). *Let  $s$  be periodic series in  $\overline{\mathbb{N}}_{\max, \gamma}[\gamma]$ . Series  $s^*$  is periodic.*

However,  $\overline{\mathbb{N}}_{\max, \gamma}^{\text{per}}[\gamma]$  is not a complete dioid: series  $s_n = (n \times n) \gamma^n$  with  $n \in \mathbb{N}$  belongs to  $\overline{\mathbb{N}}_{\max, \gamma}^{\text{per}}[\gamma]$ , but  $\bigoplus_{n \in \mathbb{N}} s_n$  does not belong to  $\overline{\mathbb{N}}_{\max, \gamma}^{\text{per}}[\gamma]$ .

**Remark 10.** *Software tools to manipulate periodic series in  $\overline{\mathbb{N}}_{\max, \gamma}[\gamma]$  exist, e.g., [13].*

### 2.7.2. Rationality

**Definition 27** (Rationality). *A series  $s$  in  $\overline{\mathbb{N}}_{\max, \gamma}[\gamma]$  is said to be rational if  $s$  belongs to the rational closure of  $\{\varepsilon, e, \gamma, 1\}$ . A matrix with entries in  $\overline{\mathbb{N}}_{\max, \gamma}[\gamma]$  is said to be rational if all its entries are rational.*

### 2.7.3. Realizability

**Definition 28** (Realizability). *A matrix  $S$  in  $\overline{\mathbb{N}}_{\max, \gamma}[\gamma]^{m \times p}$  is said to be realizable if  $S$  admits a  $(B, C)$ -representation with respect to  $\{\varepsilon, e, 1, \gamma\}$ .*

### 2.7.4. The Fundamental Theorem in $\overline{\mathbb{N}}_{\max, \gamma}[\gamma]$

**Theorem 8** ([1, 8]). *Let  $S$  be a matrix in  $\overline{\mathbb{N}}_{\max, \gamma}[\gamma]^{m \times p}$ . The following statements are equivalent:*

1.  *$S$  is periodic*
2.  *$S$  is rational*
3.  *$S$  is realizable*



In this chapter, the dioid  $\mathcal{F}_{\overline{\mathbb{N}}_{\max}}$  based on the set of residuated mappings over  $\overline{\mathbb{N}}_{\max}$  is introduced. Furthermore, the concepts of causality, periodicity, and rationality are defined in the dioid  $\mathcal{F}_{\overline{\mathbb{N}}_{\max}}$  and some properties of the dioid  $\mathcal{F}_{\overline{\mathbb{N}}_{\max}}$  are also proved. The dioid  $\mathcal{F}_{\overline{\mathbb{N}}_{\max}}$  is used in § 4 as the dioid of coefficients to develop a dioid of formal power series similar to the dioid  $\overline{\mathbb{N}}_{\max, \gamma} \llbracket \gamma \rrbracket$ .

**Definition 29** (Diod  $\mathcal{F}_{\overline{\mathbb{N}}_{\max}}$ ). *The complete dioid  $\mathcal{F}_{\overline{\mathbb{N}}_{\max}}$  is the set of residuated mappings over  $\overline{\mathbb{N}}_{\max}$  endowed with the operations  $\oplus$  and  $\otimes$  defined by*

$$\begin{aligned} \forall f_1, f_2 \in \mathcal{F}_{\overline{\mathbb{N}}_{\max}}, \quad \forall x \in \overline{\mathbb{N}}_{\max}, \quad (f_1 \oplus f_2)(x) &= f_1(x) \oplus f_2(x) \\ f_1 \otimes f_2 &= f_1 \circ f_2 \end{aligned}$$

*The order in the dioid  $\mathcal{F}_{\overline{\mathbb{N}}_{\max}}$  is induced by the order in  $\overline{\mathbb{N}}_{\max}$ , i.e.,*

$$\forall f_1, f_2 \in \mathcal{F}_{\overline{\mathbb{N}}_{\max}}, \quad f_1 \leq f_2 \Leftrightarrow \forall x \in \overline{\mathbb{N}}_{\max}, f_1(x) \leq f_2(x)$$

According to Prop. 5, the previous definition is valid. In the next two lemmas, a simple characterization of the residuated (resp. dually residuated) mappings over  $\overline{\mathbb{N}}_{\max}$  is derived from Th. 3 (resp. Th. 4) using particular properties of  $\overline{\mathbb{N}}_{\max}$ . These two lemmas are used to check whether a mapping over  $\overline{\mathbb{N}}_{\max}$  is residuated or dually residuated.

**Lemma 16.** *Let  $f$  be a mapping over  $\overline{\mathbb{N}}_{\max}$ . The following statements are equivalent:*

### 3. Dioid $\mathcal{F}_{\overline{\mathbb{N}}_{\max}}$

---

1.  $f$  is residuated
2.  $f(\varepsilon) = \varepsilon$ ,  $f$  is isotone, and  $\bigoplus_{n \in \mathbb{N}} f(n) = f(\top)$

*Proof.* 1  $\Rightarrow$  2: By definition,  $f$  is isotone. Besides, according to Th. 3,  $f(\varepsilon) = \varepsilon$  and  $f$  is lower semi-continuous. Therefore,

$$\bigoplus_{n \in \mathbb{N}} f(n) = f\left(\bigoplus_{n \in \mathbb{N}} n\right) = f(\top)$$

2  $\Rightarrow$  1: According to Th. 3, it remains to prove that  $f$  is lower semi-continuous. As  $f$  is isotone,

$$\forall \mathcal{X} \subseteq \overline{\mathbb{N}}_{\max}, \quad f\left(\bigoplus_{x \in \mathcal{X}} x\right) \geq \bigoplus_{x \in \mathcal{X}} f(x)$$

In the dioid  $\overline{\mathbb{N}}_{\max}$ ,  $\forall \mathcal{X} \subseteq \overline{\mathbb{N}}_{\max}$ ,  $\tilde{x} = \bigoplus_{x \in \mathcal{X}} x$  is either in  $\mathcal{X}$  or equal to  $\top$ . If  $\tilde{x} \in \mathcal{X}$ ,

$$\bigoplus_{x \in \mathcal{X}} f(x) \geq f(\tilde{x}) = f\left(\bigoplus_{x \in \mathcal{X}} x\right)$$

Otherwise,  $\tilde{x} = \top$ . Hence, for all  $n \in \mathbb{N}$ , there exists  $x_n \in \mathcal{X}$  such that  $x_n \geq n$ . Then,

$$\bigoplus_{x \in \mathcal{X}} f(x) \geq \bigoplus_{n \in \mathbb{N}} f(x_n) \geq \bigoplus_{n \in \mathbb{N}} f(n) = f(\top) = f(\tilde{x}) = f\left(\bigoplus_{x \in \mathcal{X}} x\right)$$

Therefore,  $f$  is lower semi-continuous. □

**Lemma 17.** *Let  $f$  be a mapping over  $\overline{\mathbb{N}}_{\max}$ . The following statements are equivalent:*

1.  $f$  is dually residuated
2.  $f(\top) = \top$  and  $f$  is isotone

*Proof.* 1  $\Rightarrow$  2: Mapping  $f$  is dually residuated. By definition,  $f$  is isotone. Besides, according to Th. 4,  $f(\top) = \top$ .

2  $\Rightarrow$  1: According to Th. 4, it remains to prove that  $f$  is upper semi-continuous. As  $f$  is isotone,

$$\forall \mathcal{X} \subseteq \overline{\mathbb{N}}_{\max}, \quad f\left(\bigwedge_{x \in \mathcal{X}} x\right) \leq \bigwedge_{x \in \mathcal{X}} f(x)$$

In the dioid  $\overline{\mathbb{N}}_{\max}$ ,  $\forall \mathcal{X} \subseteq \overline{\mathbb{N}}_{\max}$ ,  $\tilde{x} = \bigwedge_{x \in \mathcal{X}} x$  belongs to  $\mathcal{X}$ .

$$\bigwedge_{x \in \mathcal{X}} f(x) \leq f(\tilde{x}) = f\left(\bigwedge_{x \in \mathcal{X}} x\right)$$

Therefore,  $f$  is upper semi-continuous. □

As the dioid  $\mathcal{F}_{\overline{\mathbb{N}}_{\max}}$  is complete, right-division is defined in  $\mathcal{F}_{\overline{\mathbb{N}}_{\max}}$  and  $f_2 \backslash f_1$  corresponds to the greatest solution in  $\mathcal{F}_{\overline{\mathbb{N}}_{\max}}$  of  $f \otimes f_1 \leq f_2$ . The previous lemma leads, under some conditions, to a simple expression for right-division in  $\mathcal{F}_{\overline{\mathbb{N}}_{\max}}$ .

**Lemma 18.** *Let  $f_1, f_2$  be two mappings in  $\mathcal{F}_{\overline{\mathbb{N}}_{\max}}$  such that  $f_1(\top) = \top$ . Then,*

$$f_2 \backslash f_1 = f_2 \otimes f_1^b$$

*Proof.* Mapping  $f_1$  is isotone and  $f_1(\top) = \top$ . According to Lem. 17,  $f_1$  is dually residuated. As  $f_1^b$  is residuated (see Rem. 1),  $f_1^b$  belongs to  $\mathcal{F}_{\overline{\mathbb{N}}_{\max}}$ . Let  $g$  be a mapping in  $\mathcal{F}_{\overline{\mathbb{N}}_{\max}}$ . Then,

$$\begin{aligned} g \otimes f_1 \leq f_2 &\Rightarrow g \otimes f_1 \otimes f_1^b \leq f_2 \otimes f_1^b \\ &\Rightarrow g \leq f_2 \otimes f_1^b \text{ as } f_1 \otimes f_1^b \geq \text{Id} \end{aligned}$$

Furthermore,

$$\begin{aligned} g \leq f_2 \otimes f_1^b &\Rightarrow g \otimes f_1 \leq f_2 \otimes f_1^b \otimes f_1 \\ &\Rightarrow g \otimes f_1 \leq f_2 \text{ as } f_1^b \otimes f_1 \leq \text{Id} \end{aligned}$$

Hence,  $g \otimes f_1 \leq f_2 \Leftrightarrow g \leq f_2 \otimes f_1^b$ . Thus,  $f_2 \backslash f_1 = f_2 \otimes f_1^b$ .  $\square$

### 3.1. Projection on $\mathcal{F}_{\overline{\mathbb{N}}_{\max}}$

In this section, a projection, denoted  $\text{Pr}^{\mathcal{R}}$ , from the set of isotone mappings over  $\overline{\mathbb{N}}_{\max}$  to  $\mathcal{F}_{\overline{\mathbb{N}}_{\max}}$  is introduced. This allows us, in particular, to prove the distributivity of  $\mathcal{F}_{\overline{\mathbb{N}}_{\max}}$ .

**Proposition 16.** *Let  $f$  be an isotone mapping over  $\overline{\mathbb{N}}_{\max}$ . There exists a greatest mapping in  $\mathcal{F}_{\overline{\mathbb{N}}_{\max}}$ , denoted  $\text{Pr}^{\mathcal{R}}(f)$ , such that  $\text{Pr}^{\mathcal{R}}(f) \leq f$ . Mapping  $\text{Pr}^{\mathcal{R}}(f)$  is defined by*

$$\forall x \in \overline{\mathbb{N}}_{\max}, \quad \text{Pr}^{\mathcal{R}}(f)(x) = \begin{cases} \varepsilon & \text{if } x = \varepsilon \\ f(x) & \text{if } x \in \mathbb{N}_0 \\ \bigoplus_{n \in \mathbb{N}} f(n) & \text{if } x = \top \end{cases}$$

*Proof.* The mapping  $g$  over  $\overline{\mathbb{N}}_{\max}$  is defined by

$$\forall x \in \overline{\mathbb{N}}_{\max}, \quad g(x) = \begin{cases} \varepsilon & \text{if } x = \varepsilon \\ f(x) & \text{if } x \in \mathbb{N}_0 \\ \bigoplus_{n \in \mathbb{N}} f(n) & \text{if } x = \top \end{cases}$$

Clearly,  $g$  is isotone,  $g(\varepsilon) = \varepsilon$ , and

$$\bigoplus_{n \in \mathbb{N}} g(n) = \bigoplus_{n \in \mathbb{N}} f(n) = g(\top)$$

### 3. Dioid $\mathcal{F}_{\overline{\mathbb{N}}_{\max}}$

---

Therefore, according to Lem. 16,  $g$  is residuated. Furthermore, as  $f$  is isotone,

$$g(\top) = \bigoplus_{n \in \mathbb{N}} f(n) \leq f(\top)$$

Then,  $g \leq f$ . Let  $h$  be a residuated mapping less than or equal to  $f$ . For  $x = \varepsilon$ ,  $h(\varepsilon) = \varepsilon = g(\varepsilon)$ . For  $x \in \mathbb{N}_0$ ,  $h(x) \leq f(x) = g(x)$ . For  $x = \top$ ,

$$h(\top) = \bigoplus_{n \in \mathbb{N}} h(n) \leq \bigoplus_{n \in \mathbb{N}} f(n) = g(\top)$$

Hence,  $h \leq g$ . Thus,  $g$  is the greatest residuated mapping less than or equal to  $f$ .  $\square$

**Remark 11.** *The previous proposition is reminiscent of Prop. 3. However, as shown in Ex. 9, the set of isotone mappings over  $\overline{\mathbb{N}}_{\max}$  is not a complete dioid. Of course, it is possible to reformulate Prop. 3 in terms of lattices (see [2, 3]). Then, the previous proposition is a direct consequence of the lattice-version of Prop. 3, as the set of isotone mappings over  $\overline{\mathbb{N}}_{\max}$  and  $\mathcal{F}_{\overline{\mathbb{N}}_{\max}}$  are complete lattices.*

The next lemma investigates the behavior of  $\text{Pr}^{\mathcal{R}}$  with respect to  $\oplus$ .

**Lemma 19.** *Let  $f_1, f_2$  be two isotone mappings over  $\overline{\mathbb{N}}_{\max}$ . Then,*

$$\text{Pr}^{\mathcal{R}}(f_1 \oplus f_2) = \text{Pr}^{\mathcal{R}}(f_1) \oplus \text{Pr}^{\mathcal{R}}(f_2)$$

*Proof.* This comes directly from the definition of  $\text{Pr}^{\mathcal{R}}(f)$  in Prop. 16.  $\square$

As the dioid  $\mathcal{F}_{\overline{\mathbb{N}}_{\max}}$  is complete, left-division is defined in  $\mathcal{F}_{\overline{\mathbb{N}}_{\max}}$  and  $f_1 \backslash f_2$  corresponds to the greatest solution in  $\mathcal{F}_{\overline{\mathbb{N}}_{\max}}$  of  $f_1 \otimes f \leq f_2$ . The projection  $\text{Pr}^{\mathcal{R}}$  leads to a simple expression for left-division in  $\mathcal{F}_{\overline{\mathbb{N}}_{\max}}$  similar to the one obtained for right-division in Lem. 18.

**Lemma 20.** *Let  $f_1, f_2$  be two mappings in  $\mathcal{F}_{\overline{\mathbb{N}}_{\max}}$ .*

$$f_1 \backslash f_2 = \text{Pr}^{\mathcal{R}}(f_1^{\sharp} \circ f_2)$$

*Proof.* Let  $g$  be a mapping in  $\mathcal{F}_{\overline{\mathbb{N}}_{\max}}$ .

$$\begin{aligned} f_1 \otimes g \leq f_2 &\Leftrightarrow \forall x \in \overline{\mathbb{N}}_{\max}, f_1(g(x)) \leq f_2(x) \\ &\Leftrightarrow \forall x \in \overline{\mathbb{N}}_{\max}, g(x) \leq f_1^{\sharp}(f_2(x)) \\ &\Leftrightarrow g \leq f_1^{\sharp} \circ f_2 \end{aligned}$$

As  $f_1^{\sharp}$  does not belong to  $\mathcal{F}_{\overline{\mathbb{N}}_{\max}}$ ,  $f_1^{\sharp} \circ f_2$  may not belong to  $\mathcal{F}_{\overline{\mathbb{N}}_{\max}}$ . Then, as  $f_1^{\sharp} \circ f_2$  is an isotone mapping over  $\overline{\mathbb{N}}_{\max}$ , Prop. 16 leads to

$$f_1 \otimes g \leq f_2 \Leftrightarrow g \leq \text{Pr}^{\mathcal{R}}(f_1^{\sharp} \circ f_2)$$

$\square$

In a complete dioid  $\mathcal{D}$ , according to Lem. 2,

$$\mathbf{a} \bowtie \left( \bigoplus_{x \in \mathcal{X}} x \right) \geq \bigoplus_{x \in \mathcal{X}} \mathbf{a} \bowtie x \text{ and } \left( \bigoplus_{x \in \mathcal{X}} x \right) \not\bowtie \mathbf{a} \geq \bigoplus_{x \in \mathcal{X}} x \not\bowtie \mathbf{a}$$

with  $\mathbf{a} \in \mathcal{D}$  and  $\mathcal{X} \subseteq \mathcal{D}$ . In the complete dioid  $\mathcal{F}_{\overline{\mathbb{N}}_{\max}}$ , equality holds under some conditions as shown in the following lemma.

**Lemma 21.** *Let  $\mathcal{H}$  be a finite subsets of  $\mathcal{F}_{\overline{\mathbb{N}}_{\max}}$  and let  $f_1, f_2$  be two mappings in  $\mathcal{F}_{\overline{\mathbb{N}}_{\max}}$  such that  $f_2(\top) = \top$ . Then,*

$$f_1 \bowtie \left( \bigoplus_{h \in \mathcal{H}} h \right) = \bigoplus_{h \in \mathcal{H}} f_1 \bowtie h \text{ and } \left( \bigoplus_{h \in \mathcal{H}} h \right) \not\bowtie f_2 = \bigoplus_{h \in \mathcal{H}} h \not\bowtie f_2$$

*Proof.* First, left-division is considered. As  $f_1^\sharp$  is isotone,

$$\forall x \in \overline{\mathbb{N}}_{\max}, \quad \bigoplus_{h \in \mathcal{H}} f_1^\sharp(h(x)) \leq f_1^\sharp \left( \bigoplus_{h \in \mathcal{H}} h(x) \right)$$

As  $\mathcal{H}$  is finite, for all  $x \in \overline{\mathbb{N}}_{\max}$ , there exists  $h_x \in \mathcal{H}$  such that  $\bigoplus_{h \in \mathcal{H}} h(x) = h_x(x)$ . Then,

$$\forall x \in \overline{\mathbb{N}}_{\max}, \quad f_1^\sharp \left( \bigoplus_{h \in \mathcal{H}} h(x) \right) = f_1^\sharp(h_x(x)) \leq \bigoplus_{h \in \mathcal{H}} f_1^\sharp(h(x))$$

This implies

$$f_1^\sharp \circ \left( \bigoplus_{h \in \mathcal{H}} h \right) = \bigoplus_{h \in \mathcal{H}} f_1^\sharp \circ h$$

Consequently, according to Lem. 19 and Lem. 20,

$$\begin{aligned} f_1 \bowtie \left( \bigoplus_{h \in \mathcal{H}} h \right) &= \text{Pr}^{\mathcal{R}} \left( f_1^\sharp \circ \left( \bigoplus_{h \in \mathcal{H}} h \right) \right) \\ &= \text{Pr}^{\mathcal{R}} \left( \bigoplus_{h \in \mathcal{H}} f_1^\sharp \circ h \right) \\ &= \bigoplus_{h \in \mathcal{H}} \text{Pr}^{\mathcal{R}} \left( f_1^\sharp \circ h \right) \\ &= \bigoplus_{h \in \mathcal{H}} f_1 \bowtie h \end{aligned}$$

Second, right-division is considered. According to Lem. 18,

$$\begin{aligned} \left( \bigoplus_{h \in \mathcal{H}} h \right) \not\! / f_2 &= \left( \bigoplus_{h \in \mathcal{H}} h \right) \otimes f_2^\flat \\ &= \bigoplus_{h \in \mathcal{H}} \left( h \otimes f_2^\flat \right) \text{ by distributivity} \\ &= \bigoplus_{h \in \mathcal{H}} h \not\! / f_2 \end{aligned}$$

□

The projection  $\text{Pr}^{\mathcal{R}}$  is also used in the expression of the greatest lower bound in the complete dioid  $\mathcal{F}_{\overline{\mathbb{N}}_{\max}}$ . The greatest lower bound over finite subsets has already been addressed in Prop. 1. The next proposition is more general and deals with infinite subsets.

**Lemma 22.** *Let  $\mathcal{H}$  be a subset of  $\mathcal{F}_{\overline{\mathbb{N}}_{\max}}$ . Then,  $\bigwedge_{h \in \mathcal{H}} h = \text{Pr}^{\mathcal{R}}(g_{\mathcal{H}})$  where  $g_{\mathcal{H}}$  is an isotone mapping over  $\overline{\mathbb{N}}_{\max}$  defined by*

$$\forall x \in \overline{\mathbb{N}}_{\max}, \quad g_{\mathcal{H}}(x) = \bigwedge_{h \in \mathcal{H}} h(x)$$

*Proof.* Let  $f \in \mathcal{F}_{\overline{\mathbb{N}}_{\max}}$ .

$$\begin{aligned} f \leq \bigwedge_{h \in \mathcal{H}} h &\Leftrightarrow \forall h \in \mathcal{H}, \quad f \leq h \\ &\Leftrightarrow \forall h \in \mathcal{H}, \forall x \in \overline{\mathbb{N}}_{\max}, \quad f(x) \leq h(x) \\ &\Leftrightarrow \forall x \in \overline{\mathbb{N}}_{\max}, \quad f(x) \leq g_{\mathcal{H}}(x) \\ &\Leftrightarrow f \leq g_{\mathcal{H}} \end{aligned}$$

As  $g_{\mathcal{H}}$  is an isotone mapping,  $f \leq g_{\mathcal{H}} \Leftrightarrow f \leq \text{Pr}^{\mathcal{R}}(g_{\mathcal{H}})$ . Therefore,  $\bigwedge_{h \in \mathcal{H}} h = \text{Pr}^{\mathcal{R}}(g_{\mathcal{H}})$ . □

The previous lemma leads to the distributivity of  $\mathcal{F}_{\overline{\mathbb{N}}_{\max}}$ .

**Proposition 17.** *The complete dioid  $\mathcal{F}_{\overline{\mathbb{N}}_{\max}}$  is distributive.*

*Proof.* As  $\mathcal{F}_{\overline{\mathbb{N}}_{\max}}$  is a complete dioid, it remains to check that, for all  $f \in \mathcal{F}_{\overline{\mathbb{N}}_{\max}}$  and  $\mathcal{H} \subseteq \mathcal{F}_{\overline{\mathbb{N}}_{\max}}$ ,

$$f \oplus \left( \bigwedge_{h \in \mathcal{H}} h \right) = \bigwedge_{h \in \mathcal{H}} (f \oplus h) \text{ and } f \wedge \left( \bigoplus_{h \in \mathcal{H}} h \right) = \bigoplus_{h \in \mathcal{H}} (f \wedge h)$$

To prove these equalities, we use Lem. 22 and the distributivity of  $\overline{\mathbb{N}}_{\max}$ . Only the case  $x = \top$  is not obvious.

$$\begin{aligned}
 \left( f \oplus \left( \bigwedge_{h \in \mathcal{H}} h \right) \right) (\top) &= f(\top) \oplus \bigoplus_{n \in \mathbb{N}} \bigwedge_{h \in \mathcal{H}} h(n) \text{ see Lem. 22} \\
 &= \bigoplus_{n \in \mathbb{N}} \left( f(n) \oplus \bigwedge_{h \in \mathcal{H}} h(n) \right) \\
 &= \bigoplus_{n \in \mathbb{N}} \left( \bigwedge_{h \in \mathcal{H}} (f(n) \oplus h(n)) \right) \\
 &= \bigoplus_{n \in \mathbb{N}} \left( \bigwedge_{h \in \mathcal{H}} (f \oplus h) \right) (n) \\
 &= \left( \bigwedge_{h \in \mathcal{H}} (f \oplus h) \right) (\top) \text{ see Lem. 22}
 \end{aligned}$$

$$\begin{aligned}
 \left( f \wedge \left( \bigoplus_{h \in \mathcal{H}} h \right) \right) (\top) &= f(\top) \wedge \left( \bigoplus_{h \in \mathcal{H}} h \right) (\top) \text{ see Prop. 1} \\
 &= f(\top) \wedge \left( \bigoplus_{h \in \mathcal{H}} h(\top) \right) \\
 &= \bigoplus_{h \in \mathcal{H}} (f(\top) \wedge h(\top)) \\
 &= \left( \bigoplus_{h \in \mathcal{H}} (f \wedge h) \right) (\top)
 \end{aligned}$$

□

### 3.2. Subdoid $\mathcal{F}_\Delta$

In this section, a subdoid of  $\mathcal{F}_{\overline{\mathbb{N}}_{\max}}$ , denoted  $\mathcal{F}_\Delta$ , isomorphic to  $\overline{\mathbb{N}}_{\max}$  is introduced. The mapping  $\Delta$  from  $\overline{\mathbb{N}}_{\max}$  to  $\overline{\mathbb{N}}_{\max}$  is defined by  $\Delta(x) = L_1(x) = 1x$ . According to Cor. 1,  $\Delta$  belongs to  $\mathcal{F}_{\overline{\mathbb{N}}_{\max}}$  and its residual  $\Delta^\sharp$  is often denoted  $\Delta^\sharp(x) = 1 \setminus x$ .

**Lemma 23.** *The set  $\mathcal{F}_\Delta = \{\varepsilon, \top, \Delta^j \text{ with } j \in \mathbb{N}_0\}$  endowed with the operations  $\oplus$  and  $\otimes$  defined over  $\mathcal{F}_{\overline{\mathbb{N}}_{\max}}$  is a complete selective subdoid of  $\mathcal{F}_{\overline{\mathbb{N}}_{\max}}$  isomorphic to  $\overline{\mathbb{N}}_{\max}$ . Furthermore,*

### 3. Dioid $\mathcal{F}_{\overline{\mathbb{N}}_{\max}}$

there exists a single isomorphism, denoted  $\phi$ , from  $\overline{\mathbb{N}}_{\max}$  to  $\mathcal{F}_{\Delta}$ . Mapping  $\phi$  is defined by

$$\forall x \in \overline{\mathbb{N}}_{\max}, \quad \phi(x) = \begin{cases} \varepsilon & \text{if } x = \varepsilon \\ \Delta^x & \text{if } x \in \mathbb{N}_0 \\ \top & \text{if } x = \top \end{cases}$$

*Proof.* The zero element  $\varepsilon$  and the unit element  $e = \Delta^0$  of  $\mathcal{F}_{\overline{\mathbb{N}}_{\max}}$  belong to  $\mathcal{F}_{\Delta}$ . Obviously,  $\mathcal{F}_{\Delta}$  is stable for  $\oplus$  and  $\otimes$ . Then,  $\mathcal{F}_{\Delta}$  is a subdioid of  $\mathcal{F}_{\overline{\mathbb{N}}_{\max}}$ . Furthermore,  $\mathcal{F}_{\Delta}$  is stable under infinite sums. Thus,  $\mathcal{F}_{\Delta}$  is a complete subdioid of  $\mathcal{F}_{\overline{\mathbb{N}}_{\max}}$ .

The mapping  $\phi$  from  $\overline{\mathbb{N}}_{\max}$  to  $\mathcal{F}_{\Delta}$  defined before is an isomorphism. Therefore,  $\overline{\mathbb{N}}_{\max}$  and  $\mathcal{F}_{\Delta}$  are isomorphic dioids. Hence, as  $\overline{\mathbb{N}}_{\max}$  is selective,  $\mathcal{F}_{\Delta}$  is selective.

Finally, the uniqueness of  $\phi$  is checked. Let  $\psi$  be an isomorphism from  $\overline{\mathbb{N}}_{\max}$  to  $\mathcal{F}_{\Delta}$ . Then,  $\psi(\varepsilon) = \varepsilon$ , as  $\psi$  is a  $\oplus$ -morphism. We now show by induction over  $k \in \mathbb{N}_0$  that  $\psi(k) = \Delta^k$ . This equality holds for  $k = 0$ , as  $\psi$  is a  $\otimes$ -morphism. Let us assume that the equality holds for a given  $k$  in  $\mathbb{N}_0$ . As  $\psi$  is isotone,  $\psi(k+1) \geq \Delta^k$ . Equality  $\psi(k+1) = \Delta^k = \psi(k)$  is absurd, as  $\psi$  is injective. Then,  $\psi(k+1) \geq \Delta^{k+1}$ . Inequality  $\psi(k+1) \geq \Delta^{k+2}$  is also absurd, as  $\psi$  is surjective. Thus,  $\psi(k+1) = \Delta^{k+1}$ . As  $\psi$  is isotone,  $\psi(\top) \geq \Delta^j$  for all  $j \in \mathbb{N}_0$ . Consequently,  $\psi(\top) = \top$ . Hence,  $\psi = \phi$ .  $\square$

The next lemma makes explicit a nice property of mappings in  $\mathcal{F}_{\Delta}$ .

**Lemma 24.** *Let  $\alpha$  in  $\mathcal{F}_{\Delta}$  and  $f, g$  in  $\mathcal{F}_{\overline{\mathbb{N}}_{\max}}$ .*

$$\alpha(f \wedge g) = \alpha f \wedge \alpha g$$

*Proof.* There exists  $k \in \overline{\mathbb{N}}_{\max}$  such that, for all  $x \in \overline{\mathbb{N}}_{\max}$ ,  $\alpha(x) = kx$ . Then,

$$\begin{aligned} \forall x \in \overline{\mathbb{N}}_{\max}, \quad (\alpha(f \wedge g))(x) &= k(f(x) \wedge g(x)) \\ &= kf(x) \wedge kg(x) \\ &= (\alpha f)(x) \wedge (\alpha g)(x) \\ &= (\alpha f \wedge \alpha g)(x) \end{aligned}$$

$\square$

### 3.3. Quasi-Causality and Causality

In this section, the concepts of quasi-causality and causality are introduced for residuated mappings over  $\overline{\mathbb{N}}_{\max}$  (i.e., mappings in  $\mathcal{F}_{\overline{\mathbb{N}}_{\max}}$ ).

**Definition 30** (Quasi-causality). *A mapping  $f$  in  $\mathcal{F}_{\overline{\mathbb{N}}_{\max}}$  is said to be quasi-causal if  $f = \varepsilon$  or if there exists  $Y \in \mathbb{N}_0$  such that*

$$\begin{cases} f(x) = \varepsilon & \text{if } x < Y \\ f(x) \geq x & \text{if } x \geq Y \end{cases}$$



The set of quasi-causal mappings in  $\mathcal{F}_{\bar{\mathbb{N}}_{\max}}$  is denoted  $\mathcal{F}_{\bar{\mathbb{N}}_{\max}}^+$ .

**Lemma 25.** *Endowed with the operations  $\oplus$  and  $\otimes$  defined over  $\mathcal{F}_{\bar{\mathbb{N}}_{\max}}$ ,  $\mathcal{F}_{\bar{\mathbb{N}}_{\max}}^+$  is a complete subdioid of  $\mathcal{F}_{\bar{\mathbb{N}}_{\max}}$ .*

*Proof.* The zero element and the unit element of  $\mathcal{F}_{\bar{\mathbb{N}}_{\max}}$  are quasi-causal. For  $\mathcal{H} \subseteq \mathcal{F}_{\bar{\mathbb{N}}_{\max}}^+$ ,  $\bigoplus_{h \in \mathcal{H}} h$  is obviously quasi-causal. Let  $f_1$  and  $f_2$  be two mappings in  $\mathcal{F}_{\bar{\mathbb{N}}_{\max}}^+$ . If  $f_1$  or  $f_2$  is equal to  $\varepsilon$ , then  $f_1 \otimes f_2 = \varepsilon$  is quasi-causal. Otherwise,  $Y_1$  and  $Y_2$  are elements in  $\mathbb{N}_0$  defined by

$$Y_1 = \bigwedge \{x \in \bar{\mathbb{N}}_{\max} \mid f_1(x) > \varepsilon\} \text{ and } Y_2 = \bigwedge \{x \in \bar{\mathbb{N}}_{\max} \mid f_2(x) > \varepsilon\}$$

Then,  $Y = \bigwedge \{x \in \bar{\mathbb{N}}_{\max} \mid f_2(x) \geq Y_1\}$  belongs to  $\mathbb{N}_0$ , as  $f_2(Y_1 \oplus Y_2) \geq Y_1 \oplus Y_2 \geq Y_1$ , and

$$\begin{cases} (f_1 \otimes f_2)(x) = \varepsilon \text{ if } x < Y \\ (f_1 \otimes f_2)(x) \geq f_2(x) \geq x \text{ if } x \geq Y \end{cases}$$

Thus,  $\mathcal{F}_{\bar{\mathbb{N}}_{\max}}^+$  is closed with respect to  $\otimes$ . Hence,  $\mathcal{F}_{\bar{\mathbb{N}}_{\max}}^+$  is a complete subdioid of  $\mathcal{F}_{\bar{\mathbb{N}}_{\max}}$ .  $\square$

**Definition 31** (Quasi-causal projection). *The quasi-causal projection, denoted  $\text{Pr}_+$ , is a mapping from  $\mathcal{F}_{\bar{\mathbb{N}}_{\max}}$  to  $\mathcal{F}_{\bar{\mathbb{N}}_{\max}}^+$  defined as the residual of the canonical injection from  $\mathcal{F}_{\bar{\mathbb{N}}_{\max}}^+$  to  $\mathcal{F}_{\bar{\mathbb{N}}_{\max}}$ .*

As  $\mathcal{F}_{\bar{\mathbb{N}}_{\max}}^+$  is a complete subdioid of  $\mathcal{F}_{\bar{\mathbb{N}}_{\max}}$ , the canonical injection from  $\mathcal{F}_{\bar{\mathbb{N}}_{\max}}^+$  to  $\mathcal{F}_{\bar{\mathbb{N}}_{\max}}$  is residuated (see Prop. 3). Hence, the previous definition makes sense. Let  $f$  be a mapping in  $\mathcal{F}_{\bar{\mathbb{N}}_{\max}}$ . Mapping  $\text{Pr}_+(f)$  is the greatest quasi-causal mapping (i.e., in  $\mathcal{F}_{\bar{\mathbb{N}}_{\max}}^+$ ) less than or equal to  $f$ . To calculate  $\text{Pr}_+(f)$ , the subset  $\mathcal{A}$  of  $\bar{\mathbb{N}}_{\max}$  is defined by  $\mathcal{A} = \{x \in \bar{\mathbb{N}}_{\max} \mid x > f(x)\}$ . If  $\mathcal{A}$  is not finite,  $\text{Pr}_+(f) = \varepsilon$ . If  $\mathcal{A}$  is empty,  $\text{Pr}_+(f) = f$ . Otherwise,  $Z = \bigoplus_{a \in \mathcal{A}} 1_a$  belongs to  $\mathbb{N}_0$  and  $\text{Pr}_+(f)$  is defined by

$$\text{Pr}_+(f)(x) = \begin{cases} \varepsilon \text{ if } x < Z \\ f(x) \text{ if } x \geq Z \end{cases}$$

As  $\mathcal{F}_{\bar{\mathbb{N}}_{\max}}^+$  is a complete dioid, the greatest lower bound  $\wedge^+$ , the left-division  $\backslash_+$ , and the right-division  $\phi_+$  are defined in  $\mathcal{F}_{\bar{\mathbb{N}}_{\max}}^+$ . Furthermore, according to Rem. 6,

$$\begin{aligned} \forall \mathcal{H} \subseteq \mathcal{F}_{\bar{\mathbb{N}}_{\max}}^+, \quad \bigwedge_{h \in \mathcal{H}}^+ h &= \text{Pr}_+ \left( \bigwedge_{h \in \mathcal{H}} h \right) \\ \forall f, g \in \mathcal{F}_{\bar{\mathbb{N}}_{\max}}^+, \quad f \backslash_+ g &= \text{Pr}_+(f \backslash g) \text{ and } g \phi_+ f = \text{Pr}_+(g \phi f) \end{aligned}$$

**Lemma 26.** *The operation  $\wedge^+$  in  $\mathcal{F}_{\bar{\mathbb{N}}_{\max}}^+$  coincides with the operation  $\wedge$  in  $\mathcal{F}_{\bar{\mathbb{N}}_{\max}}$  over  $\mathcal{F}_{\bar{\mathbb{N}}_{\max}}^+$ . Formally, let  $\mathcal{H} \subseteq \mathcal{F}_{\bar{\mathbb{N}}_{\max}}^+$ ,  $\bigwedge_{h \in \mathcal{H}}^+ h = \bigwedge_{h \in \mathcal{H}} h$ .*

### 3. Dioid $\mathcal{F}_{\overline{\mathbb{N}}_{\max}}$

*Proof.* To prove the previous equality, it is sufficient to show that  $\bigwedge_{h \in \mathcal{H}} h$  is quasi-causal. If  $\varepsilon \in \mathcal{H}$ , then  $\bigwedge_{h \in \mathcal{H}} h = \varepsilon$  is quasi-causal. Otherwise, for all  $h \in \mathcal{H}$ ,

$$Y_h = \bigwedge \{x \in \overline{\mathbb{N}}_{\max} \mid h(x) \geq x\} \in \mathbb{N}_0$$

Let  $Y = \bigoplus_{h \in \mathcal{H}} Y_h$ .

If  $Y = \top$ , for all  $x \in \mathbb{N}_0$ , there exists  $h \in \mathcal{H}$  such that  $h(x) = \varepsilon$ . Then,

$$\forall x \in \mathbb{N}_0, \quad \left( \bigwedge_{h \in \mathcal{H}} h \right) (x) = \bigwedge_{h \in \mathcal{H}} h(x) = \varepsilon$$

Furthermore,

$$\left( \bigwedge_{h \in \mathcal{H}} h \right) (\top) = \bigoplus_{n \in \mathbb{N}} \left( \bigwedge_{h \in \mathcal{H}} h(n) \right) = \varepsilon$$

Hence,  $\bigwedge_{h \in \mathcal{H}} h = \varepsilon$  is quasi-causal.

Otherwise,  $Y \in \mathbb{N}_0$ ,

$$\forall x < Y, \quad \left( \bigwedge_{h \in \mathcal{H}} h \right) (x) = \bigwedge_{h \in \mathcal{H}} h(x) = \varepsilon$$

$$\forall x \geq Y, x \neq \top, \quad \left( \bigwedge_{h \in \mathcal{H}} h \right) (x) = \bigwedge_{h \in \mathcal{H}} h(x) \geq x$$

$$x = \top, \quad \left( \bigwedge_{h \in \mathcal{H}} h \right) (\top) = \bigoplus_{n \in \mathbb{N}} \left( \bigwedge_{h \in \mathcal{H}} h(n) \right) \geq \bigoplus_{n \geq Y} n = \top$$

Hence,  $\bigwedge_{h \in \mathcal{H}} h$  is quasi-causal.  $\square$

**Definition 32** (Causality). A mapping  $f$  in  $\mathcal{F}_{\overline{\mathbb{N}}_{\max}}$  is said to be causal if  $f = \varepsilon$  or if, for all  $x \in \overline{\mathbb{N}}_{\max}$ ,  $f(x) \geq x$ . The set of causal mappings in  $\mathcal{F}_{\overline{\mathbb{N}}_{\max}}$  is denoted  $\mathcal{F}_{\overline{\mathbb{N}}_{\max}}^{++}$ .

**Lemma 27.** Endowed with the operations  $\oplus$  and  $\otimes$  defined over  $\mathcal{F}_{\overline{\mathbb{N}}_{\max}}$ ,  $\mathcal{F}_{\overline{\mathbb{N}}_{\max}}^{++}$  is a complete subdioid of  $\mathcal{F}_{\overline{\mathbb{N}}_{\max}}$ .

*Proof.* The unit element and the zero element of  $\mathcal{F}_{\overline{\mathbb{N}}_{\max}}$  are causal. For  $\mathcal{H} \subseteq \mathcal{F}_{\overline{\mathbb{N}}_{\max}}^{++}$ ,  $\bigoplus_{h \in \mathcal{H}} h$  is obviously causal. Let  $f_1$  and  $f_2$  be two mappings in  $\mathcal{F}_{\overline{\mathbb{N}}_{\max}}^{++}$ . If  $f_1$  or  $f_2$  is equal to  $\varepsilon$ , then  $f_1 \otimes f_2 = \varepsilon$  is causal. Otherwise,

$$\forall x \in \overline{\mathbb{N}}_{\max}, \quad (f_1 \otimes f_2)(x) \geq f_2(x) \geq x$$

Thus,  $\mathcal{F}_{\overline{\mathbb{N}}_{\max}}^{++}$  is closed with respect to  $\otimes$ . Hence,  $\mathcal{F}_{\overline{\mathbb{N}}_{\max}}^{++}$  is a complete subdioid of  $\mathcal{F}_{\overline{\mathbb{N}}_{\max}}$ .  $\square$

**Definition 33** (Causal projection). *The causal projection, denoted  $\text{Pr}_{++}$ , is a mapping from  $\mathcal{F}_{\overline{\mathbb{N}}_{\max}}$  to  $\mathcal{F}_{\overline{\mathbb{N}}_{\max}}^{++}$  defined as the residual of the canonical injection from  $\mathcal{F}_{\overline{\mathbb{N}}_{\max}}^{++}$  to  $\mathcal{F}_{\overline{\mathbb{N}}_{\max}}$ .*

As  $\mathcal{F}_{\overline{\mathbb{N}}_{\max}}^{++}$  is a complete subdioid of  $\mathcal{F}_{\overline{\mathbb{N}}_{\max}}$ , the canonical injection from  $\mathcal{F}_{\overline{\mathbb{N}}_{\max}}^{++}$  to  $\mathcal{F}_{\overline{\mathbb{N}}_{\max}}$  is residuated (see Prop. 3). Hence, the previous definition makes sense. Let  $f$  be a mapping in  $\mathcal{F}_{\overline{\mathbb{N}}_{\max}}$ . Mapping  $\text{Pr}_{++}(f)$  is the greatest causal mapping (i.e., in  $\mathcal{F}_{\overline{\mathbb{N}}_{\max}}^{++}$ ) less than or equal to  $f$ . To calculate  $\text{Pr}_{++}(f)$ , the subset  $\mathcal{A}$  of  $\overline{\mathbb{N}}_{\max}$  is defined by  $\mathcal{A} = \{x \in \overline{\mathbb{N}}_{\max} \mid x > f(x)\}$ . If  $\mathcal{A}$  is not empty,  $\text{Pr}_{++}(f) = \varepsilon$ . If  $\mathcal{A}$  is empty,  $\text{Pr}_{++}(f) = f$ .

As  $\mathcal{F}_{\overline{\mathbb{N}}_{\max}}^{++}$  is a complete dioid, the greatest lower bound  $\wedge^{++}$ , the left-division  $\backslash_{++}$ , and the right-division  $\not\!/\!_{++}$  are defined. Furthermore, according to Rem. 6,

$$\begin{aligned} \forall \mathcal{H} \subseteq \mathcal{F}_{\overline{\mathbb{N}}_{\max}}^{++}, \quad \bigwedge_{h \in \mathcal{H}}^{++} h &= \text{Pr}_{++} \left( \bigwedge_{h \in \mathcal{H}} h \right) \\ \forall f, g \in \mathcal{F}_{\overline{\mathbb{N}}_{\max}}^{++}, \quad f \backslash_{++} g &= \text{Pr}_{++}(f \backslash g) \quad \text{and} \quad g \not\!/\!_{++} f = \text{Pr}_{++}(g \not\!/\! f) \end{aligned}$$

**Lemma 28.** *The operation  $\wedge^{++}$  in  $\mathcal{F}_{\overline{\mathbb{N}}_{\max}}^{++}$  coincides with the operation  $\wedge$  in  $\mathcal{F}_{\overline{\mathbb{N}}_{\max}}$  over  $\mathcal{F}_{\overline{\mathbb{N}}_{\max}}^{++}$ . Formally, let  $\mathcal{H} \subseteq \mathcal{F}_{\overline{\mathbb{N}}_{\max}}^{++}$ ,  $\bigwedge_{h \in \mathcal{H}}^{++} h = \bigwedge_{h \in \mathcal{H}} h$ .*

*Proof.* To prove the previous equality, it is sufficient to show that  $\bigwedge_{h \in \mathcal{H}} h$  is causal. If  $\varepsilon \in \mathcal{H}$ ,  $\bigwedge_{h \in \mathcal{H}} h = \varepsilon$  is causal. Otherwise, for all  $h \in \mathcal{H}$  and for all  $x \in \overline{\mathbb{N}}_{\max}$ ,  $h(x) \geq x$ . Then,

$$\begin{aligned} \forall x \neq \top, \quad \left( \bigwedge_{h \in \mathcal{H}} h \right) (x) &= \bigwedge_{h \in \mathcal{H}} h(x) \geq x \\ x = \top, \quad \left( \bigwedge_{h \in \mathcal{H}} h \right) (\top) &= \bigoplus_{n \in \mathbb{N}} \left( \bigwedge_{h \in \mathcal{H}} h(n) \right) \geq \bigoplus_{n \in \mathbb{N}} n = \top \end{aligned}$$

Hence,  $\bigwedge_{h \in \mathcal{H}} h$  is causal. □

### 3.4. Periodicity

In this section, the concept of periodicity is introduced for mappings in  $\mathcal{F}_{\overline{\mathbb{N}}_{\max}}$ .

**Definition 34** (Periodicity). *A mapping  $f$  in  $\mathcal{F}_{\overline{\mathbb{N}}_{\max}}$  is said to be periodic with respect to  $X \in \mathbb{N}_0$  and  $\omega \in \mathbb{N}$  if*

$$\forall x \geq X, \quad f(\omega x) = \omega f(x)$$

A mapping  $f$  periodic with respect to  $X$  and  $\omega$  is completely defined by its values  $f(k)$  with  $e \leq k < \omega X$ . The following lemma makes explicit a property of periodic mappings, which plays an essential role in §4.

### 3. Dioid $\mathcal{F}_{\overline{\mathbb{N}}_{\max}}$

---

**Lemma 29.** *Let  $f$  be a mapping in  $\mathcal{F}_{\overline{\mathbb{N}}_{\max}}$  periodic with respect to  $X$  and  $\omega$ . Then,*

$$f\Delta^{X+\omega} = \Delta^\omega f\Delta^X$$

*Proof.* If  $x = \varepsilon$ ,

$$f\Delta^{X+\omega}(\varepsilon) = \varepsilon = \Delta^\omega f\Delta^X(\varepsilon)$$

Otherwise,  $Xx \geq X$ . Therefore,

$$f\Delta^{X+\omega}(x) = f(\omega Xx) = \omega f(Xx) = \Delta^\omega f\Delta^X(x)$$

□

#### 3.4.1. Calculation with Periodic Mappings

Next, properties of periodic mappings with respect to operations  $\oplus$ ,  $\wedge$ ,  $\otimes$ ,  $\backslash$ , and  $\phi$  is investigated.

##### Sum of Periodic Mappings

**Proposition 18** (Sum of periodic mappings). *Let  $f_1$  (resp.  $f_2$ ) be a mapping in  $\mathcal{F}_{\overline{\mathbb{N}}_{\max}}$  periodic with respect to  $X_1$  (resp.  $X_2$ ) in  $\mathbb{N}_0$  and  $\omega_1$  (resp.  $\omega_2$ ) in  $\mathbb{N}$ . Mapping  $f_1 \oplus f_2$  is periodic with respect to  $X = X_1 \oplus X_2$  and  $\omega = \text{lcm}(\omega_1, \omega_2)$ .*

*Proof.*

$$\begin{aligned} \forall x \geq X, \quad (f_1 \oplus f_2)(\omega x) &= f_1(\omega x) \oplus f_2(\omega x) \\ &= \omega f_1(x) \oplus \omega f_2(x) \\ &= \omega (f_1 \oplus f_2)(x) \end{aligned}$$

□

##### Greatest Lower Bound of Periodic Mappings

**Proposition 19** (Greatest lower bound of periodic mappings). *Let  $f_1$  (resp.  $f_2$ ) be a mapping in  $\mathcal{F}_{\overline{\mathbb{N}}_{\max}}$  periodic with respect to  $X_1$  (resp.  $X_2$ ) in  $\mathbb{N}_0$  and  $\omega_1$  (resp.  $\omega_2$ ) in  $\mathbb{N}$ . Mapping  $f_1 \wedge f_2$  is periodic with respect to  $X = X_1 \oplus X_2$  and  $\omega = \text{lcm}(\omega_1, \omega_2)$ .*

*Proof.* According to Prop. 1,

$$\forall x \in \overline{\mathbb{N}}_{\max}, \quad (f_1 \wedge f_2)(x) = f_1(x) \wedge f_2(x)$$

Hence,

$$\begin{aligned}
 \forall x \geq X, \quad (f_1 \wedge f_2)(\omega x) &= f_1(\omega x) \wedge f_2(\omega x) \\
 &= \omega f_1(x) \wedge \omega f_2(x) \\
 &= \omega(f_1(x) \wedge f_2(x)) \text{ see Rem. 4} \\
 &= \omega(f_1 \wedge f_2)(x)
 \end{aligned}$$

□

### Product of Periodic Mappings

**Proposition 20** (Product of periodic mappings). *Let  $f_1$  (resp.  $f_2$ ) be a mapping in  $\mathcal{F}_{\overline{\mathbb{N}}_{\max}}$  periodic with respect to  $X_1$  (resp.  $X_2$ ) in  $\mathbb{N}_0$  and  $\omega_1$  (resp.  $\omega_2$ ) in  $\mathbb{N}$ . Mapping  $f_1 \otimes f_2$  is periodic with respect to*

$$\begin{aligned}
 X &= \begin{cases} 0 & \text{if } f_2 = \varepsilon \\ X_2 \oplus \bigwedge \{x \in \overline{\mathbb{N}}_{\max} \mid f_2(x) \geq X_1\} & \text{otherwise} \end{cases} \\
 \omega &= \text{lcm}(\omega_1, \omega_2)
 \end{aligned}$$

*Proof.* If  $f_2 = \varepsilon$ , then  $f_1 \otimes f_2 = \varepsilon$  is periodic with respect to 0 and  $\omega$ . Otherwise, by periodicity, there exists  $x \in \mathbb{N}_0$  such that  $f_2(x) \geq X_1$ . Therefore,  $X$  belongs to  $\mathbb{N}_0$ . For  $x \geq X$ ,

$$\begin{aligned}
 (f_1 \otimes f_2)(\omega x) &= f_1(\omega f_2(x)) \text{ as } x \geq X_2 \\
 &= \omega(f_1 \otimes f_2)(x) \text{ as } f_2(x) \geq X_1
 \end{aligned}$$

□

### Left-Division of Periodic Mappings

In the following, the periodicity of  $f_1 \setminus f_2$  is investigated when  $f_1$  and  $f_2$  are periodic mappings in  $\mathcal{F}_{\overline{\mathbb{N}}_{\max}}$ .

**Example 14.** *Let  $f_1$  and  $f_2$  be two causal periodic mappings in  $\mathcal{F}_{\overline{\mathbb{N}}_{\max}}$  defined by*

$$f_1(x) = \begin{cases} x & \text{if } x < 3 \\ \top & \text{if } x \geq 3 \end{cases} \quad \text{and } f_2(x) = x$$

Then,

$$(f_1 \setminus f_2)(x) = \text{Pr}^{\mathcal{R}}(f_1^\# \circ f_2)(x) = \begin{cases} x & \text{if } x < 2 \\ 2 & \text{if } x \geq 2 \end{cases}$$

Therefore, mapping  $f_1 \setminus f_2$  is not periodic.

Ex. 14 shows that the periodicity of  $f_1$  and of  $f_2$  does not imply the periodicity of  $f_1 \bowtie f_2$ . From now on, we focus on the quasi-causal case. In the following, we investigate the periodicity of  $f_1 \bowtie_+ f_2$  when  $f_1$  and  $f_2$  are quasi-causal periodic mappings in  $\mathcal{F}_{\overline{\mathbb{N}}_{\max}}$ . First, the effect of the periodicity of  $f$  on its residual  $f^\sharp$  is examined.

**Lemma 30.** *Let  $f$  be a periodic (with respect to  $X$  and  $\omega$ ) mapping in  $\mathcal{F}_{\overline{\mathbb{N}}_{\max}}$ . Then,*

$$\forall y \geq f(X), \quad f^\sharp(\omega y) = \omega f^\sharp(y)$$

*Proof.*

$$\begin{aligned} \forall y \geq f(X), \quad f^\sharp(\omega y) &= \bigoplus \{x \in \overline{\mathbb{N}}_{\max} \mid f(x) \leq \omega y\} \\ &= \bigoplus \{x \geq \omega X \mid f(x) \leq \omega y\} \\ &= \omega \bigoplus \{x \geq X \mid f(x) \leq y\} \\ &= \omega \bigoplus \{x \in \overline{\mathbb{N}}_{\max} \mid f(x) \leq y\} \\ &= \omega f^\sharp(y) \end{aligned}$$

□

**Proposition 21.** *Let  $f_1$  (resp.  $f_2$ ) be a quasi-causal mapping in  $\mathcal{F}_{\overline{\mathbb{N}}_{\max}}$  periodic with respect to  $X_1$  (resp.  $X_2$ ) in  $\mathbb{N}_0$  and  $\omega_1$  (resp.  $\omega_2$ ) in  $\mathbb{N}$ . Mapping  $f_1 \bowtie_+ f_2$  is periodic with respect to  $X = X_1 \oplus X_2$  and  $\omega = \text{lcm}(\omega_1, \omega_2)$ .*

*Proof.* According to Lem. 20,  $f_1 \bowtie f_2 = \text{Pr}^{\mathcal{R}}(f_1^\sharp \circ f_2)$ . Then,

$$f_1 \bowtie_+ f_2 = \text{Pr}_+(f_1 \bowtie f_2) = \text{Pr}_+(\text{Pr}^{\mathcal{R}}(f_1^\sharp \circ f_2))$$

In the following, two cases are distinguished.

**First Case:** We assume that, for all  $Z \in \mathbb{N}_0$ , there exists  $z \geq Z$  such that  $f_1(z) > f_2(z)$ . If  $(f_1^\sharp \circ f_2)(z) \geq z$ ,

$$f_2(z) \geq (f_1 \circ f_1^\sharp \circ f_2)(z) \geq f_1(z) > f_2(z)$$

This is absurd. Then,  $(f_1^\sharp \circ f_2)(z) < z$ . Hence, for all  $Z \in \mathbb{N}_0$ , there exists  $z \geq Z$  such that  $\text{Pr}^{\mathcal{R}}(f_1^\sharp \circ f_2)(z) < z$ . Then,

$$f_1 \bowtie_+ f_2 = \text{Pr}_+(\text{Pr}^{\mathcal{R}}(f_1^\sharp \circ f_2)) = \varepsilon$$

Mapping  $f_1 \bowtie_+ f_2$  is periodic with respect to  $X$  and  $\omega$ .

**Second Case:** We assume that there exists  $Z \in \mathbb{N}_0$  such that,  $\forall x \geq Z, f_1(x) \leq f_2(x)$ . By periodicity,  $\forall x \geq X, f_1(x) \leq f_2(x)$ . Hence,

$$\forall x \geq X, \quad \left( f_1^\# \circ f_2 \right) (x) \geq \left( f_1^\# \circ f_1 \right) (x) \geq x$$

This leads to

$$\forall x \geq X, \quad \left( f_1 \downarrow_+ f_2 \right) (x) = \left( f_1^\# \circ f_2 \right) (x)$$

Thus,

$$\begin{aligned} \forall x \geq X, \quad \left( f_1 \downarrow_+ f_2 \right) (\omega x) &= \left( f_1^\# \circ f_2 \right) (\omega x) \\ &= f_1^\# (\omega f_2(x)) \text{ as } x \geq X \geq X_2 \end{aligned}$$

As, for  $x \geq X, f_2(x) \geq f_1(x) \geq f_1(X_1)$ , Lem. 30 leads to

$$\begin{aligned} \forall x \geq X, \quad \left( f_1 \downarrow_+ f_2 \right) (\omega x) &= \omega \left( f_1^\# \circ f_2 \right) (x) \\ &= \omega \left( f_1 \downarrow_+ f_2 \right) (x) \end{aligned}$$

Mapping  $f_1 \downarrow_+ f_2$  is periodic with respect to  $X$  and  $\omega$ . □

### Right-Division of Periodic Mappings

In the following, the periodicity of  $f_2 \circ f_1$  is investigated when  $f_1$  and  $f_2$  are periodic.

**Example 15.** Let  $f_1$  and  $f_2$  be two causal periodic mappings in  $\mathcal{F}_{\mathbb{N}_{\max}}$  defined by

$$f_1(x) = \begin{cases} x & \text{if } x < 3 \\ \top & \text{if } x \geq 3 \end{cases} \quad \text{and } f_2(x) = x$$

Then,

$$\left( f_2 \circ f_1 \right) (x) = \left( f_2 \otimes f_1^\flat \right) (x) = \begin{cases} x & \text{if } x < 3 \\ 3 & \text{if } x \geq 3 \end{cases}$$

Mapping  $f_2 \circ f_1$  is not periodic.

Ex. 15 shows that the periodicity of  $f_1$  and of  $f_2$  does not imply the periodicity of  $f_2 \circ f_1$ . From now on, we focus on the quasi-causal case. In the following, we investigate the periodicity of  $f_2 \circ f_1$  when  $f_1$  and  $f_2$  are quasi-causal periodic mappings in  $\mathcal{F}_{\mathbb{N}_{\max}}$ . Next, for a dually residuated mapping  $f$ , the effect of the periodicity of  $f$  on its dual residual  $f^\flat$  is examined.

**Lemma 31.** *Let  $f$  be a dually residuated periodic (with respect to  $X$  and  $\omega$ ) mapping in  $\mathcal{F}_{\overline{\mathbb{N}}_{\max}}$  such that  $f(X) \neq \top$ . Then,  $f^\flat$  is periodic with respect to  $1f(X)$  and  $\omega$ .*

*Proof.* As  $f$  is dually residuated,  $f \neq \varepsilon$ . Furthermore,  $f(X) \neq \top$  implies  $1f(X) \in \mathbb{N}_0$ . Then,

$$\begin{aligned} \forall y \geq 1f(X), \quad f^\flat(\omega y) &= \bigwedge \{x \in \overline{\mathbb{N}}_{\max} \mid f(x) \geq \omega y\} \\ &= \bigwedge \{x > \omega X \mid f(x) \geq \omega y\} \\ &= \omega \bigwedge \{x > X \mid f(x) \geq y\} \\ &= \omega \bigwedge \{x \in \overline{\mathbb{N}}_{\max} \mid f(x) \geq y\} \\ &= \omega f^\flat(y) \end{aligned}$$

□

**Proposition 22.** *Let  $f_1$  (resp.  $f_2$ ) be a quasi-causal mapping in  $\mathcal{F}_{\overline{\mathbb{N}}_{\max}}$  periodic with respect to  $X_1$  (resp.  $X_2$ ) in  $\mathbb{N}_0$  and  $\omega_1$  (resp.  $\omega_2$ ) in  $\mathbb{N}$ . Mapping  $f_2 \phi_+ f_1$  is periodic with respect to*

$$\begin{aligned} X &= \begin{cases} e \oplus 1f_1(X_1 \oplus X_2) & \text{if } f_1(X_1) \neq \top \\ e \oplus 1f_1(\bigwedge \{x \in \overline{\mathbb{N}}_{\max} \mid f_1(x) = \top\} \phi 1) & \text{otherwise} \end{cases} \\ \omega &= \text{lcm}(\omega_1, \omega_2) \end{aligned}$$

*Proof.* If  $f_1 = \varepsilon$ ,  $f_2 \phi_+ f_1 = \top$  is periodic with respect to  $X$  and  $\omega$ . In the following, we assume that  $f_1 \neq \varepsilon$ . As  $f_1$  is a non-zero quasi-causal mapping,  $f_1(\top) = \top$ . Then, according to Lem. 18,

$$f_2 \phi_+ f_1 = \text{Pr}_+(f_2 \phi f_1) = \text{Pr}_+(f_2 \otimes f_1^\flat)$$

Let  $Y = \bigwedge \{x \in \overline{\mathbb{N}}_{\max} \mid f_1(x) = \top\}$ . In the following, three cases are distinguished.

**First Case:** We assume that, for all  $Z \in \mathbb{N}_0$ , there exists  $z \geq Z$  such that  $f_1(z) > f_2(z)$ . Then, for all  $Z \in \mathbb{N}_0$ , there exists  $z \geq Z \oplus X_1$  such that  $f_1(z) > f_2(z)$ . Thus, as  $f_1^\flat \otimes f_1 \leq \text{Id}$ ,

$$f_1(z) > f_2(z) \geq (f_2 \otimes f_1^\flat \otimes f_1)(z)$$

As  $f_1 \neq \varepsilon$  and  $z \geq Z \oplus X_1$ ,  $f_1(z) \geq Z$ . Then, for all  $Z \in \mathbb{N}_0$ , there exists  $z' = f_1(z) \geq Z$  such that

$$(f_2 \phi f_1)(z') = f_2(f_1^\flat(z')) < z'$$

Consequently, due to quasi-causality,  $f_2 \phi_+ f_1 = \varepsilon$  is periodic with respect to  $X$  and  $\omega$ .



**Second Case:** We assume that  $Y \in \mathbb{N}_0$  and that there exists  $Z \in \mathbb{N}_0$  such that, for all  $x \geq Z$ ,  $f_2(x) \geq f_1(x)$ . For  $x \geq e \oplus 1f_1(Y \neq 1)$ ,  $f_1^b(x) = Y$ . Then,

$$\forall x \geq e \oplus 1f_1(Y \neq 1), \quad (f_2 \neq f_1)(x) = f_2(Y)$$

Consequently,

$$\forall x \geq e \oplus 1f_1(Y \neq 1), \quad (f_2 \neq_+ f_1)(x) = \begin{cases} \top & \text{if } f_2(Y) = \top \\ \varepsilon & \text{otherwise} \end{cases}$$

Therefore,  $f_2 \neq_+ f_1$  is periodic with respect to  $X = e \oplus 1f_1(Y \neq 1)$  and  $\omega$ .

**Third Case:** We assume that  $Y = \top$  and that there exists  $Z \in \mathbb{N}_0$  such that, for all  $x \geq Z$ ,  $f_2(x) \geq f_1(x)$ . By periodicity,  $\forall x \geq X_1 \oplus X_2$ ,  $f_2(x) \geq f_1(x)$ . Then,  $\forall x \geq e \oplus 1f_1(X_1 \oplus X_2)$ ,  $f_1^b(x) \geq X_1 \oplus X_2$ . This leads to

$$\forall x \geq e \oplus 1f_1(X_1 \oplus X_2), \quad (f_2 \neq f_1)(x) = (f_2 \otimes f_1^b)(x) \geq (f_1 \otimes f_1^b)(x) \geq x$$

Therefore,

$$\forall x \geq e \oplus 1f_1(X_1 \oplus X_2), \quad (f_2 \neq_+ f_1)(x) = (f_2 \neq f_1)(x) = (f_2 \otimes f_1^b)(x)$$

Hence,

$$\begin{aligned} \forall x \geq e \oplus 1f_1(X_1 \oplus X_2), \quad (f_2 \neq_+ f_1)(\omega x) &= (f_2 \otimes f_1^b)(\omega x) \\ &= f_2(\omega f_1^b(x)) \text{ according to Lem. 31} \\ &= \omega f_2(f_1^b(x)) \text{ as } f_1^b(x) \geq X_2 \\ &= \omega (f_2 \neq_+ f_1)(x) \end{aligned}$$

Therefore,  $f_2 \neq_+ f_1$  is periodic with respect to  $X = e \oplus 1f_1(X_1 \oplus X_2)$  and  $\omega$ .  $\square$

### 3.5. Rationality

The complete dioid  $\overline{\mathbb{N}}_{\max, \gamma}[\![\gamma]\!]$  has already been introduced in §2.7. It corresponds to the dioid of isotone formal power series  $s$  with coefficients in  $\overline{\mathbb{N}}_{\max}$  and with a single variable  $\gamma$  such that  $s(k) = \varepsilon$  for  $k < 0$ . Based on  $\overline{\mathbb{N}}_{\max, \gamma}[\![\gamma]\!]$ , a particular class of causal elements in  $\mathcal{F}_{\overline{\mathbb{N}}_{\max}}$  is presented and the concepts of rationality for mappings in  $\mathcal{F}_{\overline{\mathbb{N}}_{\max}}$  is introduced.

**Definition 35** ( $\alpha$ -mapping). *The  $\alpha$ -mapping  $\alpha_s$  associated with a series  $s \in \overline{\mathbb{N}}_{\max, \gamma}[\![\gamma]\!]$  is the causal element in  $\mathcal{F}_{\overline{\mathbb{N}}_{\max}}$  defined by*

$$\alpha_s(x) = \bigwedge \{z \geq x \mid z \in \text{Im}(s) \cup \{\top\}\}$$

### 3. Dioid $\mathcal{F}_{\overline{\mathbb{N}}_{\max}}$

---

A link exists between the periodicity of a series in  $\overline{\mathbb{N}}_{\max, \gamma} \llbracket \gamma \rrbracket$  and the periodicity of the associated  $\alpha$ -mapping in  $\mathcal{F}_{\overline{\mathbb{N}}_{\max}}$ .

**Proposition 23.** *Let  $s$  be a series in  $\overline{\mathbb{N}}_{\max, \gamma} \llbracket \gamma \rrbracket$ . If  $s$  is periodic, then  $\alpha_s$  is periodic.*

*Proof.* Depending on the throughput of series  $s$ , four cases are distinguished.

$s = \varepsilon$ :  $\alpha_s = \top$  is periodic.

$\sigma(s) = 0$ :  $s$  is a polynomial with the canonical representative  $\bigoplus_{k=1}^N a_k \gamma^{n_k}$  such that  $N \in \mathbb{N}$ ,  $0 \leq n_1 < \dots < n_N$ , and  $e \leq a_1 < \dots < a_N = \top$ . If  $N \geq 2$ ,  $\alpha_s(x) = \top$  for  $x \geq 1a_{N-1}$ . Otherwise (i.e.,  $N = 1$ ),  $\alpha_s = \top$ . Thus,  $\alpha_s$  is periodic with respect to

$$X = \begin{cases} 1a_{N-1} & \text{if } N \geq 2 \\ e & \text{if } N = 1 \end{cases} \quad \text{and } \omega = 1$$

$\sigma(s) = +\infty$ :  $s$  is a polynomial with the canonical representative  $\bigoplus_{k=1}^N a_k \gamma^{n_k}$  such that  $N \in \mathbb{N}$ ,  $0 \leq n_1 < \dots < n_N$ , and  $e \leq a_1 < \dots < a_N < \top$ . Then,  $\alpha_s(x) = \top$  for  $x \geq 1a_N$ . Thus,  $\alpha_s$  is periodic with respect to  $X = 1a_N$  and  $\omega = 1$ .

$0 < \sigma(s) < +\infty$ : There exist  $K \in \mathbb{N}_0$  and  $\tau, \nu \in \mathbb{N}$  such that  $s(K) \in \mathbb{N}_0$  and  $s(k + \nu) = \tau s(k)$  for  $k \geq K$ . For  $\top > x \geq 1s(K)$ ,

$$\begin{aligned} \alpha_s(\tau x) &= \bigwedge \{s(k) \geq \tau x \mid k \in \mathbb{Z}\} \\ &= \bigwedge \{s(k) \geq \tau x \mid k > K + \nu\} \\ &= \tau \bigwedge \{s(k) \geq x \mid k > K\} \\ &= \tau \alpha_s(x) \end{aligned}$$

Thus,  $\alpha_s$  is periodic with respect to  $X = 1s(K)$  and  $\omega = \tau$ . □

The concept of rationality in  $\mathcal{F}_{\overline{\mathbb{N}}_{\max}}$  is based on  $\alpha$ -mappings.

**Definition 36 (Rationality).** *A mapping  $f$  in  $\mathcal{F}_{\overline{\mathbb{N}}_{\max}}$  is said to be rational if there exists a finite set  $\{r_1, \dots, r_N\}$  of periodic series in  $\overline{\mathbb{N}}_{\max, \gamma} \llbracket \gamma \rrbracket$  such that  $f$  belongs to the rational closure of  $\{\varepsilon, e, \alpha_{r_1}, \dots, \alpha_{r_N}\}$ . An expression of  $f$  as an element of the rational closure of  $\{\varepsilon, e, \alpha_{r_1}, \dots, \alpha_{r_N}\}$  is called a rational expression of  $f$ .*

**Proposition 24.** *Let  $f$  be a causal periodic mapping in  $\mathcal{F}_{\overline{\mathbb{N}}_{\max}}$ . Then,  $f$  is rational.*

*Proof.* Mapping  $f$  is a causal mapping in  $\mathcal{F}_{\overline{\mathbb{N}}_{\max}}$ :  $f = \varepsilon$  or  $f(x) \geq x$  for all  $x \in \overline{\mathbb{N}}_{\max}$ . Obviously,  $\varepsilon$  is rational. Next, the case  $f(x) \geq x$  for all  $x \in \overline{\mathbb{N}}_{\max}$  is considered. By assumption,

$f$  is periodic with respect to  $X \in \mathbb{N}_0$  and  $\omega \in \mathbb{N}$ . First,  $f$  is written as a finite sum of simple causal periodic mappings in  $\mathcal{F}_{\overline{\mathbb{N}}_{\max}}$ .

$$f = \bigoplus_{i=0}^{X+\omega-1} f_i$$

where the causal periodic mappings  $f_i$  are defined by

$$\forall i \text{ such that } 0 \leq i < X, \quad f_i(x) = \begin{cases} x & \text{if } x < i \\ x \oplus f(i) & \text{otherwise} \end{cases}$$

$$\forall i \text{ such that } X \leq i < X + \omega, \quad f_i(x) = \begin{cases} x & \text{if } x < i \\ \omega^j f(i) \oplus x & \text{if } \omega^j i \leq x < \omega^{j+1} i \text{ with } j \in \mathbb{N}_0 \\ \top & \text{if } x = \top \end{cases}$$

Second, the rationality of the mappings  $f_i$  is investigated in each case. If  $0 \leq i < X$ , then  $f_i = \alpha_{r_i}$  where

$$r_i = \bigoplus_{k=0}^{i-1} k\gamma^k \oplus f(i)\gamma^i (1\gamma)^*$$

If  $X + \omega > i \geq X$ , two subcases are distinguished depending on  $L = (1f(i))\not\phi(\omega i)$ . If  $L = \varepsilon$ ,  $f_i = \alpha_{r_i}$  where

$$r_i = \bigoplus_{k=0}^{i-1} k\gamma^k \oplus \left( \bigoplus_{k=0}^{M-1} (kf(i))\gamma^{i+k} \right) (\omega\gamma^M)^*$$

with  $M = (\omega i)\not\phi(1f(i))$ . Otherwise, the discussion is slightly more complicated. First of all, the particular case corresponding to  $\omega = 1$  comes down to periodic mappings with  $\omega = 2$ . Indeed, if  $\omega = 1$ , then  $f_i = f_{1,i} \oplus f_{2,i}$  with causal periodic mappings  $f_{1,i}$  and  $f_{2,i}$  defined by

$$f_{1,i}(x) = \begin{cases} x & \text{if } x < i \\ f(i)\not\phi 1 & \text{if } x = i \\ 1 \otimes 2^j f(i) & \text{if } 1 \otimes 2^j i \leq x < 3 \otimes 2^j i \text{ with } j \in \mathbb{N}_0 \end{cases}$$

$$f_{2,i}(x) = \begin{cases} x & \text{if } x < i \\ 2^j f(i) & \text{if } 2^j i \leq x < 2^{j+1} i \text{ with } j \in \mathbb{N}_0 \end{cases}$$

Afterwards, we assume that  $\omega \geq 2$ . Then,  $f_i = \bigotimes_{l=0}^L \alpha_{r_{i,L-l}}$  with

$$r_{i,l} = \bigoplus_{k=0}^{i-1} k\gamma^k \oplus (il\omega\not\phi 1)\gamma^i (\omega\gamma)^*$$

□

3. Dioid  $\mathcal{F}_{\overline{\mathbb{N}}_{\max}}$

---

**Example 16.** Rational expressions of some particular causal periodic mappings in  $\mathcal{F}_{\overline{\mathbb{N}}_{\max}}$  are presented. First,  $\Delta = \alpha_{r_1} \oplus \alpha_{r_2}$  with  $r_1 = (2\gamma)^*$  and  $r_2 = 1(2\gamma)^*$ . Second, the causal periodic mapping  $g$  defined by

$$g(x) = \begin{cases} x & \text{if } x < 4 \\ 7 \otimes 3^j & \text{if } 4 \otimes 3^j \leq x < 7 \otimes 3^j \text{ with } j \in \mathbb{N}_0 \\ \top & \text{if } x = \top \end{cases}$$

admits the rational expression  $\alpha_{r_2} \alpha_{r_1}$  with

$$\begin{aligned} r_1 &= e \oplus 1\gamma \oplus 2\gamma^2 \oplus 3\gamma^3 \oplus 6\gamma^4 (3\gamma)^* \\ r_2 &= e \oplus 1\gamma \oplus 2\gamma^2 \oplus 3\gamma^3 \oplus 7\gamma^4 (3\gamma)^* \end{aligned}$$

In this chapter, the dioid  $\mathcal{F}_{\overline{\mathbb{N}}_{\max}, \gamma}[\gamma]$  is investigated. This dioid is built by analogy with the dioid  $\overline{\mathbb{N}}_{\max, \gamma}[\gamma]$ . However, the coefficients of the formal power series belong to  $\mathcal{F}_{\overline{\mathbb{N}}_{\max}}$  instead of belonging to  $\overline{\mathbb{N}}_{\max}$ . The main objective of this chapter is to obtain a fundamental theorem in the dioid  $\mathcal{F}_{\overline{\mathbb{N}}_{\max}, \gamma}[\gamma]$  similar to the one in the dioid  $\overline{\mathbb{N}}_{\max, \gamma}[\gamma]$  (see Th. 8).

**Definition 37** (Diod  $\mathcal{F}_{\overline{\mathbb{N}}_{\max}, \gamma}[\gamma]$ ). *The distributive dioid  $\mathcal{F}_{\overline{\mathbb{N}}_{\max}, \gamma}[\gamma]$  is defined as the dioid of isotone formal power series in  $\gamma$  with coefficients in the distributive dioid  $\mathcal{F}_{\overline{\mathbb{N}}_{\max}}$  equal to  $\varepsilon$  over  $\{k \in \mathbb{Z} | k < 0\}$ .*

According to Prop. 9 and Lem. 14, the previous definition is valid. By definition, a series  $s$  in  $\mathcal{F}_{\overline{\mathbb{N}}_{\max}, \gamma}[\gamma]$  is an isotone mapping from  $\mathbb{Z}$  to  $\mathcal{F}_{\overline{\mathbb{N}}_{\max}}$  such that  $s(k) = \varepsilon$  for  $k < 0$ . Then,  $s(k)(x)$  denotes the value in  $\overline{\mathbb{N}}_{\max}$  of the mapping  $s(k)$  at  $x \in \overline{\mathbb{N}}_{\max}$ . Next, an alternative representation for series in  $\mathcal{F}_{\overline{\mathbb{N}}_{\max}, \gamma}[\gamma]$  is introduced.

**Definition 38** (Slicing mapping  $\psi$ ). *The slicing mapping  $\psi$  is a mapping from  $\mathcal{F}_{\overline{\mathbb{N}}_{\max}, \gamma}[\gamma]$  to the set of mappings from  $\overline{\mathbb{N}}_{\max}$  to  $\overline{\mathbb{N}}_{\max, \gamma}[\gamma]$  defined by*

$$\forall s \in \mathcal{F}_{\overline{\mathbb{N}}_{\max}, \gamma}[\gamma], \forall x \in \overline{\mathbb{N}}_{\max}, \quad \psi(s)(x) = \bigoplus_{k \in \mathbb{Z}} s(k)(x) \gamma^k$$

or, equivalently,

$$\forall s \in \mathcal{F}_{\overline{\mathbb{N}}_{\max}, \gamma}[\gamma], \forall x \in \overline{\mathbb{N}}_{\max}, \forall k \in \mathbb{Z}, \quad \psi(s)(x)(k) = s(k)(x)$$

**Remark 12.** Basic properties of the slicing mapping  $\psi$  are

$$\begin{aligned} \forall s \in \mathcal{F}_{\overline{\mathbb{N}}_{\max, \gamma}}[\gamma], \forall x \in \overline{\mathbb{N}}_{\max}, \quad \psi(\gamma s)(x) &= \gamma \psi(s)(x) \\ \psi(\Delta s)(x) &= 1 \psi(s)(x) \end{aligned}$$

**Lemma 32.** Let  $s$  be a series in  $\mathcal{F}_{\overline{\mathbb{N}}_{\max, \gamma}}[\gamma]$ . The mapping  $\psi(s)$  from  $\overline{\mathbb{N}}_{\max}$  to  $\overline{\mathbb{N}}_{\max, \gamma}[\gamma]$  is residuated.

*Proof.* This proof is based on Th. 3. For all  $k \in \mathbb{Z}$ , as mapping  $s(k)$  is residuated,  $s(k)(\varepsilon) = \varepsilon$  and  $s(k)$  is lower semi-continuous. Then,

$$\begin{aligned} \psi(s)(\varepsilon) &= \bigoplus_{k \in \mathbb{Z}} s(k)(\varepsilon) \gamma^k = \varepsilon \\ \forall \mathcal{X} \subseteq \overline{\mathbb{N}}_{\max}, \quad \psi(s)\left(\bigoplus_{x \in \mathcal{X}} x\right) &= \bigoplus_{k \in \mathbb{Z}} s(k)\left(\bigoplus_{x \in \mathcal{X}} x\right) \gamma^k \\ &= \bigoplus_{k \in \mathbb{Z}} \bigoplus_{x \in \mathcal{X}} s(k)(x) \gamma^k \\ &= \bigoplus_{x \in \mathcal{X}} \psi(s)(x) \end{aligned}$$

Hence,  $\psi(s)$  is residuated. □

The previous lemma shows that the slicing mapping  $\psi$  is actually a mapping from  $\mathcal{F}_{\overline{\mathbb{N}}_{\max, \gamma}}[\gamma]$  to the set of residuated mappings from  $\overline{\mathbb{N}}_{\max}$  to  $\overline{\mathbb{N}}_{\max, \gamma}[\gamma]$ , denoted  $\mathcal{F}_R(\overline{\mathbb{N}}_{\max}, \overline{\mathbb{N}}_{\max, \gamma}[\gamma])$ .

**Lemma 33.** The slicing mapping  $\psi$  from  $\mathcal{F}_{\overline{\mathbb{N}}_{\max, \gamma}}[\gamma]$  to  $\mathcal{F}_R(\overline{\mathbb{N}}_{\max}, \overline{\mathbb{N}}_{\max, \gamma}[\gamma])$  is bijective. The mapping  $\psi^{-1}$  from  $\mathcal{F}_R(\overline{\mathbb{N}}_{\max}, \overline{\mathbb{N}}_{\max, \gamma}[\gamma])$  to  $\mathcal{F}_{\overline{\mathbb{N}}_{\max, \gamma}}[\gamma]$  is defined by

$$\forall S \in \mathcal{F}_R(\overline{\mathbb{N}}_{\max}, \overline{\mathbb{N}}_{\max, \gamma}[\gamma]), \forall k \in \mathbb{Z}, \forall x \in \overline{\mathbb{N}}_{\max}, \quad \psi^{-1}(S)(k)(x) = S(x)(k)$$

Furthermore, mappings  $\psi$  and  $\psi^{-1}$  are isotone. Hence,  $\psi$  is residuated.

*Proof.* Let  $\phi$  be the mapping from  $\mathcal{F}_R(\overline{\mathbb{N}}_{\max}, \overline{\mathbb{N}}_{\max, \gamma}[\gamma])$  to  $\mathcal{F}_{\overline{\mathbb{N}}_{\max, \gamma}}[\gamma]$  defined by

$$\forall S \in \mathcal{F}_R(\overline{\mathbb{N}}_{\max}, \overline{\mathbb{N}}_{\max, \gamma}[\gamma]), \forall k \in \mathbb{Z}, \forall x \in \overline{\mathbb{N}}_{\max}, \quad \phi(S)(k)(x) = S(x)(k)$$

First, we check that  $\phi$  is well-defined. For  $S \in \mathcal{F}_R(\overline{\mathbb{N}}_{\max}, \overline{\mathbb{N}}_{\max, \gamma}[\gamma])$  and  $k \in \mathbb{Z}$ ,

$$\phi(S)(k)(\varepsilon) = S(\varepsilon)(k) = \varepsilon(k) = \varepsilon$$

$$\begin{aligned} \forall \mathcal{X} \subseteq \overline{\mathbb{N}}_{\max}, \quad \phi(S)(k)\left(\bigoplus_{x \in \mathcal{X}} x\right) &= S\left(\bigoplus_{x \in \mathcal{X}} x\right)(k) \\ &= \bigoplus_{x \in \mathcal{X}} S(x)(k) \\ &= \bigoplus_{x \in \mathcal{X}} \phi(S)(k)(x) \end{aligned}$$

Therefore,  $\phi(S)(k)$  is residuated, *i.e.*,  $\phi(S)(k)$  belongs to  $\mathcal{F}_{\overline{\mathbb{N}}_{\max}}$ . Furthermore, for  $k, j \in \mathbb{Z}$ ,

$$\begin{aligned} k \geq j &\Rightarrow \forall x \in \overline{\mathbb{N}}_{\max}, \quad S(x)(k) \geq S(x)(j) \\ &\Rightarrow \forall x \in \overline{\mathbb{N}}_{\max}, \quad \phi(S)(k)(x) \geq \phi(S)(j)(x) \\ &\Rightarrow \phi(S)(k) \geq \phi(S)(j) \\ k < 0 &\Rightarrow \forall x \in \overline{\mathbb{N}}_{\max}, \quad S(x)(k) = \varepsilon \\ &\Rightarrow \forall x \in \overline{\mathbb{N}}_{\max}, \quad \psi(S)(k)(x) = \varepsilon \\ &\Rightarrow \forall x \in \overline{\mathbb{N}}_{\max}, \quad \psi(S)(k) = \varepsilon \end{aligned}$$

Hence,  $\phi(S)$  belongs to  $\mathcal{F}_{\overline{\mathbb{N}}_{\max}, \gamma}[\gamma]$ .

Second,  $\phi \circ \psi = \text{Id}$  and  $\psi \circ \phi = \text{Id}$ . Then,  $\psi$  is bijective and  $\psi^{-1} = \phi$ .

Finally, let  $s_1, s_2 \in \mathcal{F}_{\overline{\mathbb{N}}_{\max}, \gamma}[\gamma]$  and  $S_1, S_2 \in \mathcal{F}_R(\overline{\mathbb{N}}_{\max}, \overline{\mathbb{N}}_{\max, \gamma}[\gamma])$  such that  $S_1 = \psi(s_1)$  and  $S_2 = \psi(s_2)$ .

$$\begin{aligned} s_1 = \psi^{-1}(S_1) \geq s_2 = \psi^{-1}(S_2) &\Leftrightarrow \forall k \in \mathbb{Z}, \forall x \in \overline{\mathbb{N}}_{\max}, s_1(k)(x) \geq s_2(k)(x) \\ &\Leftrightarrow \forall k \in \mathbb{Z}, \forall x \in \overline{\mathbb{N}}_{\max}, S_1(x)(k) \geq S_2(x)(k) \\ &\Leftrightarrow S_1 = \psi(s_1) \geq S_2 = \psi(s_2) \end{aligned}$$

Thus, mappings  $\psi$  and  $\psi^{-1}$  are isotone.  $\square$

The next lemma investigates how the operations  $\oplus$ ,  $\otimes$ , and  $\wedge$  in  $\mathcal{F}_{\overline{\mathbb{N}}_{\max}, \gamma}[\gamma]$  interact with the slicing mapping  $\psi$ .

**Lemma 34.** *Let  $s_1, s_2$  be two series in  $\mathcal{F}_{\overline{\mathbb{N}}_{\max}, \gamma}[\gamma]$ . Then,*

$$\begin{aligned} \forall x \in \overline{\mathbb{N}}_{\max}, \quad \psi(s_1 \oplus s_2)(x) &= \psi(s_1)(x) \oplus \psi(s_2)(x) \\ \psi(s_1 \wedge s_2)(x) &= \psi(s_1)(x) \wedge \psi(s_2)(x) \\ \psi(s_1 \otimes s_2)(x) &= \bigoplus_{j \in \mathbb{Z}} \psi(s_1)(\psi(s_2)(x)(j)) \gamma^j \end{aligned}$$

*Proof.* For the sum  $\oplus$ ,

$$\begin{aligned} \forall x \in \overline{\mathbb{N}}_{\max}, \quad \psi(s_1 \oplus s_2)(x) &= \bigoplus_{j \in \mathbb{Z}} (s_1 \oplus s_2)(j)(x) \gamma^j \\ &= \bigoplus_{j \in \mathbb{Z}} (s_1(j)(x) \oplus s_2(j)(x)) \gamma^j \\ &= \bigoplus_{j \in \mathbb{Z}} s_1(j)(x) \gamma^j \oplus \bigoplus_{j \in \mathbb{Z}} s_2(j)(x) \gamma^j \\ &= \psi(s_1)(x) \oplus \psi(s_2)(x) \end{aligned}$$

For the greatest lower bound  $\wedge$ ,

$$\begin{aligned} \forall x \in \overline{\mathbb{N}}_{\max}, \quad \psi(s_1 \wedge s_2)(x) &= \bigoplus_{j \in \mathbb{Z}} (s_1 \wedge s_2)(j)(x) \gamma^j \\ &= \bigoplus_{j \in \mathbb{Z}} (s_1(j)(x) \wedge s_2(j)(x)) \gamma^j \end{aligned}$$

Therefore,

$$\forall x \in \overline{\mathbb{N}}_{\max}, \forall j \in \mathbb{Z}, \quad \psi(s_1 \wedge s_2)(x)(j) = s_1(j)(x) \wedge s_2(j)(x)$$

Furthermore,

$$\begin{aligned} \forall x \in \overline{\mathbb{N}}_{\max}, \forall j \in \mathbb{Z}, \quad (\psi(s_1)(x) \wedge \psi(s_2)(x))(j) &= \psi(s_1)(x)(j) \wedge \psi(s_2)(x)(j) \\ &= s_1(j)(x) \wedge s_2(j)(x) \end{aligned}$$

Thus,

$$\forall x \in \overline{\mathbb{N}}_{\max}, \quad \psi(s_1 \wedge s_2)(x) = \psi(s_1)(x) \wedge \psi(s_2)(x)$$

For the product  $\otimes$ ,

$$\begin{aligned} \forall x \in \overline{\mathbb{N}}_{\max}, \quad \psi(s_1 \otimes s_2)(x) &= \bigoplus_{j \in \mathbb{Z}} (s_1 \otimes s_2)(j)(x) \gamma^j \\ &= \bigoplus_{j \in \mathbb{Z}} \bigoplus_{l \in \mathbb{Z}} s_1(j-l)(s_2(l)(x)) \gamma^j \\ &= \bigoplus_{l \in \mathbb{Z}} \psi(s_1)(s_2(l)(x)) \gamma^l \\ &= \bigoplus_{l \in \mathbb{Z}} \psi(s_1)(\psi(s_2)(x)(l)) \gamma^l \end{aligned}$$

□

Next, a simple example illustrates the intuitive graphical interpretation of the slicing mapping.

**Example 17.** Let  $s$  be a series in  $\mathcal{F}_{\overline{\mathbb{N}}_{\max}, \gamma}[\Gamma]$  defined by

$$s = \gamma \oplus f\gamma^3 \text{ with } f(x) = \begin{cases} \varepsilon & \text{if } x = \varepsilon \\ 3 \lfloor \frac{x}{3} \rfloor & \text{if } x \in \mathbb{N}_0 \\ \top & \text{if } x = \top \end{cases}$$



The  $\gamma$ -support of  $s$  is  $\{1, 3\}$ . Then,  $s$  is a polynomial with the canonical representative  $\gamma \oplus f\gamma^3$ . The mapping  $\psi(s)$  in  $\mathcal{F}_R(\overline{\mathbb{N}}_{\max}, \overline{\mathbb{N}}_{\max, \gamma}[\![\gamma]\!])$  is defined by

$$\psi(s)(x) = \begin{cases} \varepsilon & \text{if } x = \varepsilon \\ x\gamma & \text{if } x = 3^j \text{ with } j \in \mathbb{N}_0 \\ x\gamma \oplus 2x\gamma^3 & \text{if } x = 1 \otimes 3^j \text{ with } j \in \mathbb{N}_0 \\ x\gamma \oplus 1x\gamma^3 & \text{if } x = 2 \otimes 3^j \text{ with } j \in \mathbb{N}_0 \\ \top\gamma & \text{if } x = \top \end{cases}$$

A graphical representation of series  $s$  is drawn in Fig. 4.1. The expression  $s = \gamma \oplus f\gamma^3$  leads to the planes  $(x, s(k)(x))$  for  $k \in \mathbb{Z}$  (i.e., corresponding to the 2D-representation of the mapping  $s(k)$  in  $\mathcal{F}_{\overline{\mathbb{N}}_{\max}}$ ). The series  $\psi(s)(x)$  provides the planes  $(k, s(k)(x))$  for  $x \in \overline{\mathbb{N}}_{\max}$  (i.e., corresponding to the 2D-representation of the series  $\psi(s)(x)$  in  $\overline{\mathbb{N}}_{\max, \gamma}[\![\gamma]\!]$ ):  $\psi(s)(x)$  corresponds to the slice of the series  $s$  at  $x \in \overline{\mathbb{N}}_{\max}$ .

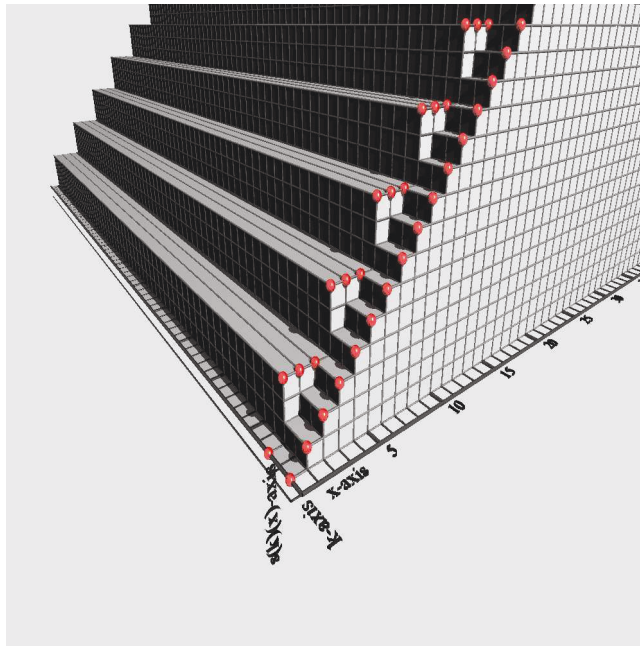

Figure 4.1.: Series  $s = \gamma \oplus f\gamma^3$

### 4.1. Subdioid $\mathcal{F}_{\Delta, \gamma}[\gamma]$

**Definition 39** (Dioid  $\mathcal{F}_{\Delta, \gamma}[\gamma]$ ). *The distributive dioid  $\mathcal{F}_{\Delta, \gamma}[\gamma]$  is defined as the dioid of isotone formal power series in  $\gamma$  with coefficients in the distributive dioid  $\mathcal{F}_{\Delta}$  equal to  $\varepsilon$  over  $\{k \in \mathbb{Z} \mid k < 0\}$ .*

According to Prop. 9 and Lem. 14, the previous definition is valid. Obviously,  $\mathcal{F}_{\Delta, \gamma}[\gamma]$  is a subdioid of the dioid  $\mathcal{F}_{\overline{\mathbb{N}}_{\max, \gamma}[\gamma]}$ . According to Lem. 23,  $\mathcal{F}_{\Delta}$  is isomorphic to  $\overline{\mathbb{N}}_{\max}$ . Then,  $\mathcal{F}_{\Delta, \gamma}[\gamma]$  is isomorphic to  $\overline{\mathbb{N}}_{\max, \gamma}[\gamma]$ . An isomorphism  $\Phi$  from  $\overline{\mathbb{N}}_{\max, \gamma}[\gamma]$  to  $\mathcal{F}_{\Delta, \gamma}[\gamma]$  is defined by,  $\forall s \in \overline{\mathbb{N}}_{\max, \gamma}[\gamma]$ ,  $\Phi(s) = \phi \circ s$ , where  $\phi$  is the isomorphism from  $\overline{\mathbb{N}}_{\max}$  to  $\mathcal{F}_{\Delta}$  mentioned in Lem. 23. Therefore, all results presented in § 2.7 are transposed in  $\mathcal{F}_{\Delta, \gamma}[\gamma]$  through the isomorphism  $\Phi$ . In particular, the concepts of periodic series and throughput are directly extended to  $\mathcal{F}_{\Delta, \gamma}[\gamma]$ . Furthermore, the calculation rules for periodic series developed in § 2.7 are also valid in  $\mathcal{F}_{\Delta, \gamma}[\gamma]$ .

The following lemma illustrates a link between the slicing mapping  $\psi$  and the isomorphism  $\Phi$  from  $\overline{\mathbb{N}}_{\max, \gamma}[\gamma]$  to  $\mathcal{F}_{\Delta, \gamma}[\gamma]$ .

**Lemma 35.** *Let  $s$  be a series in  $\overline{\mathbb{N}}_{\max, \gamma}[\gamma]$ . Then,  $\psi(\Phi(s))(e) = s$ .*

*Proof.* First, notice that, for all  $x \in \overline{\mathbb{N}}_{\max}$ ,  $\phi(x)(e) = x$  where  $\phi$  is the isomorphism from  $\overline{\mathbb{N}}_{\max}$  to  $\mathcal{F}_{\Delta}$  mentioned in Lem. 23. Then,

$$\begin{aligned} \psi(\Phi(s))(e) &= \bigoplus_{k=0}^{+\infty} \Phi(s)(k)(e) \gamma^k \\ &= \bigoplus_{k=0}^{+\infty} \phi(s(k))(e) \gamma^k \\ &= \bigoplus_{k=0}^{+\infty} s(k) \gamma^k \\ &= s \end{aligned}$$

□

**Example 18.** *Let  $s = \gamma \oplus \Delta^3 \gamma^3$ , a series in  $\mathcal{F}_{\Delta, \gamma}[\gamma]$ . The mapping  $\psi(s)$  is defined by*

$$\psi(s)(x) = \begin{cases} \varepsilon & \text{if } x = \varepsilon \\ x(\gamma \oplus 3\gamma^3) & \text{if } x \in \mathbb{N}_0 \\ \top \gamma & \text{if } x = \top \end{cases}$$

*Series  $s$  is associated with series  $\gamma \oplus 3\gamma^3$  in  $\overline{\mathbb{N}}_{\max, \gamma}[\gamma]$ . A graphical representation of series  $s$  is drawn in Fig. 4.2.*

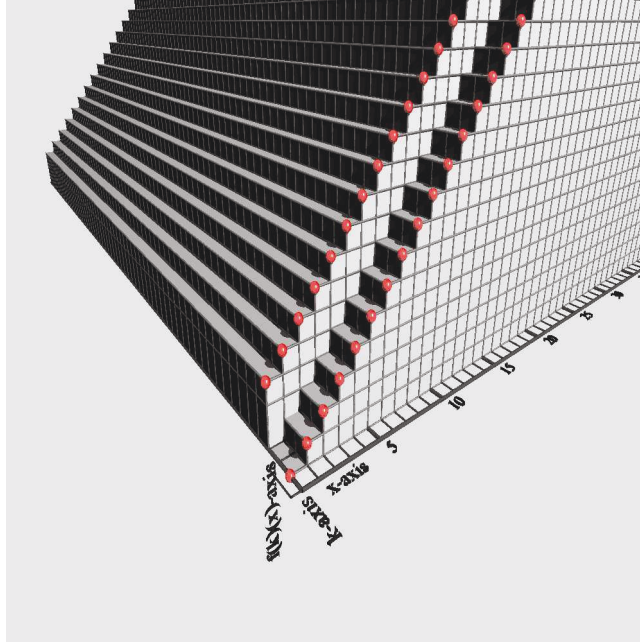

Figure 4.2.: Series  $s = \gamma \oplus \Delta^3 \gamma^3$

## 4.2. Quasi-Causality and Causality

The concepts of causality and quasi-causality introduced in § 3 for  $\mathcal{F}_{\mathbb{N}_{\max}}$  are extended to the dioid  $\mathcal{F}_{\mathbb{N}_{\max}, \gamma}[\gamma]$ .

**Definition 40** (Quasi-causality). *A series  $s$  in  $\mathcal{F}_{\mathbb{N}_{\max}, \gamma}[\gamma]$  is said to be quasi-causal if  $s(k)$  is quasi-causal for all  $k \in \mathbb{Z}$ .*

The set of quasi-causal series in  $\mathcal{F}_{\mathbb{N}_{\max}, \gamma}[\gamma]$  is denoted  $\mathcal{F}_{\mathbb{N}_{\max}, \gamma}^+[\gamma]$ . In the next lemma, the algebraic structure of  $\mathcal{F}_{\mathbb{N}_{\max}, \gamma}^+[\gamma]$  is investigated.

**Lemma 36.** *Endowed with the operations  $\oplus$  and  $\otimes$  defined over  $\mathcal{F}_{\mathbb{N}_{\max}, \gamma}[\gamma]$ ,  $\mathcal{F}_{\mathbb{N}_{\max}, \gamma}^+[\gamma]$  is a complete subdioid of  $\mathcal{F}_{\mathbb{N}_{\max}, \gamma}[\gamma]$ .*

*Proof.* This is a direct consequence of Lem. 12, Lem. 25, and Prop. 9. □

**Definition 41** (Causality). *A series  $s$  in  $\mathcal{F}_{\mathbb{N}_{\max}, \gamma}[\gamma]$  is said to be causal if  $s(k)$  is causal for  $k \in \mathbb{Z}$ .*

*A matrix with entries in  $\mathcal{F}_{\mathbb{N}_{\max}, \gamma}[\gamma]$  is said to be causal if all its entries are causal series.*

#### 4. Dioid $\mathcal{F}_{\overline{\mathbb{N}}_{\max}, \gamma} \llbracket \gamma \rrbracket$

---

The set of causal series in  $\mathcal{F}_{\overline{\mathbb{N}}_{\max}, \gamma} \llbracket \gamma \rrbracket$  is denoted  $\mathcal{F}_{\overline{\mathbb{N}}_{\max}, \gamma}^{++} \llbracket \gamma \rrbracket$ . In the next lemma, the algebraic structure of  $\mathcal{F}_{\overline{\mathbb{N}}_{\max}, \gamma}^{++} \llbracket \gamma \rrbracket$  is discussed.

**Lemma 37.** *Endowed with the operations  $\oplus$  and  $\otimes$  defined over  $\mathcal{F}_{\overline{\mathbb{N}}_{\max}, \gamma} \llbracket \gamma \rrbracket$ ,  $\mathcal{F}_{\overline{\mathbb{N}}_{\max}, \gamma}^{++} \llbracket \gamma \rrbracket$  is a complete subdioid of  $\mathcal{F}_{\overline{\mathbb{N}}_{\max}, \gamma} \llbracket \gamma \rrbracket$ .*

*Proof.* This is a direct consequence of Lem. 12, Lem. 27, and Prop. 9.  $\square$

According to Prop. 3, the canonical injection from  $\mathcal{F}_{\overline{\mathbb{N}}_{\max}, \gamma}^{++} \llbracket \gamma \rrbracket$  to  $\mathcal{F}_{\overline{\mathbb{N}}_{\max}, \gamma} \llbracket \gamma \rrbracket$  is residuated. Its residual is named causal projection and denoted  $\text{Pr}_{++}$ . For  $s \in \mathcal{F}_{\overline{\mathbb{N}}_{\max}, \gamma} \llbracket \gamma \rrbracket$ ,  $\text{Pr}_{++}(s)$  is the greatest causal series less than or equal to  $s$ . Furthermore, the causal projection is defined by

$$\forall s \in \mathcal{F}_{\overline{\mathbb{N}}_{\max}, \gamma} \llbracket \gamma \rrbracket, \quad \text{Pr}_{++}(s)(k) = \text{Pr}_{++}(s)(k)$$

A simple characterization of  $\mathcal{F}_{\overline{\mathbb{N}}_{\max}, \gamma}^{++} \llbracket \gamma \rrbracket$  is based on the mapping  $\psi$ .

**Proposition 25.** *Let  $s$  be a non-zero series in  $\mathcal{F}_{\overline{\mathbb{N}}_{\max}, \gamma} \llbracket \gamma \rrbracket$ . The following statements are equivalent:*

1.  $s$  is causal
2.  $\forall x \in \overline{\mathbb{N}}_{\max}, \psi(s)(x) \geq x\gamma^{\text{val}(s)}$

*Proof.*  $1 \Rightarrow 2$ : By assumption,  $s$  is causal. As  $s$  is a non-zero causal series,  $\text{val}(s) \in \mathbb{N}_0$  and  $s(\text{val}(s))$  is a causal mapping in  $\mathcal{F}_{\overline{\mathbb{N}}_{\max}}$  different from  $\varepsilon$ . Consequently,

$$\forall x \in \overline{\mathbb{N}}_{\max}, \quad \psi(s)(x) \geq s(\text{val}(s))(x)\gamma^{\text{val}(s)} \geq x\gamma^{\text{val}(s)}$$

$2 \Rightarrow 1$ : For all  $x \in \overline{\mathbb{N}}_{\max}$ ,  $\psi(s)(x)$  is greater than or equal to  $x\gamma^{\text{val}(s)}$ . First,  $s(k) \neq \varepsilon$  implies  $s(k) \geq s(\text{val}(s))$ . This leads to, for all  $x \in \overline{\mathbb{N}}_{\max}$ ,  $s(k)(x) \geq s(\text{val}(s))(x) \geq x$ , as  $\psi(s)(x) \geq x\gamma^{\text{val}(s)}$ . Then, for all  $k \geq \text{val}(s)$ ,  $s(k)$  is causal. Consequently,  $s$  is causal.  $\square$

### 4.3. Periodicity

The concept of periodicity introduced in § 3 for  $\mathcal{F}_{\overline{\mathbb{N}}_{\max}}$  is extended to  $\mathcal{F}_{\overline{\mathbb{N}}_{\max}, \gamma} \llbracket \gamma \rrbracket$  by analogy with periodicity in  $\overline{\mathbb{N}}_{\max, \gamma} \llbracket \gamma \rrbracket$ .

**Definition 42** (Periodicity). *A series  $s$  in  $\mathcal{F}_{\overline{\mathbb{N}}_{\max}, \gamma} \llbracket \gamma \rrbracket$  is said to be periodic if there exist  $N \in \mathbb{N}$ , periodic mappings  $f_1, \dots, f_N$  in  $\mathcal{F}_{\overline{\mathbb{N}}_{\max}}$ ,  $n_1, \dots, n_N$  in  $\mathbb{N}_0$ ,  $\tau_1, \dots, \tau_N$  in  $\mathbb{N}_0$ , and  $\nu$  in  $\mathbb{N}$  such that*

$$s = \bigoplus_{k=1}^N (\Delta^{\tau_k} \gamma^\nu)^* f_k \gamma^{n_k}$$

*A matrix with entries in  $\mathcal{F}_{\overline{\mathbb{N}}_{\max}, \gamma} \llbracket \gamma \rrbracket$  is said to be periodic if all its entries are periodic.*

The following proposition investigates the periodicity of the causal projection of a periodic series.

**Proposition 26.** *Let  $s$  be a periodic series in  $\mathcal{F}_{\overline{\mathbb{N}}_{\max}, \gamma}[\gamma]$ . The causal projection of  $s$ , denoted  $\text{Pr}_{++}(s)$ , is periodic.*

*Proof.* There exist  $N \in \mathbb{N}$ , periodic mappings  $f_1, \dots, f_N$  in  $\mathcal{F}_{\overline{\mathbb{N}}_{\max}}$ ,  $n_1, \dots, n_N$  in  $\mathbb{N}_0$ ,  $\tau_1, \dots, \tau_N$  in  $\mathbb{N}_0$ , and  $\nu$  in  $\mathbb{N}$  such that

$$s = \bigoplus_{k=1}^N (\Delta^{\tau_k} \gamma^\nu)^* f_k \gamma^{n_k}$$

If, for all  $j \in \mathbb{Z}$ ,  $s(j)$  is either equal to  $\varepsilon$  or non-causal, then  $\text{Pr}_{++}(s) = \varepsilon$  is periodic. Otherwise, let  $J$  be the least element in  $\mathbb{N}_0$  such that  $s(J)$  is a non-zero causal mapping in  $\mathcal{F}_{\overline{\mathbb{N}}_{\max}}$ . Then,

$$\text{Pr}_{++}(s) = s(J) \gamma^J \bigoplus_{k=1}^N s_k$$

with

$$s_k = \begin{cases} (\Delta^{\tau_k} \gamma^\nu)^* f_k \gamma^{n_k} & \text{if } n_k \geq J \\ (\Delta^{\tau_k} \gamma^\nu)^* \Delta^{L_k \tau_k} f_k \gamma^{n_k + L_k \nu} & \text{with } L_k = \lceil \frac{J - n_k}{\nu} \rceil \text{ if } n_k < J \end{cases}$$

Thus,  $\text{Pr}_{++}(s)$  is periodic.  $\square$

**Example 19.** *The series  $s = f_1 \oplus (\Delta^2 \gamma)^* f_2 \oplus (\Delta^3 \gamma)^* f_3$  where  $f_1, f_2$ , and  $f_3$  are periodic mappings in  $\mathcal{F}_{\overline{\mathbb{N}}_{\max}}$  defined by*

$$f_1(x) = \begin{cases} \varepsilon & \text{if } x = \varepsilon \\ 3 & \text{if } x = 0, 1, 2 \\ x & \text{if } x \geq 3 \end{cases}$$

$$f_2(x) = \begin{cases} \varepsilon & \text{if } x \leq 2 \\ 5 & \text{if } x = 3, 4 \\ x & \text{if } x \geq 5 \end{cases}$$

$$f_3(x) = \begin{cases} \varepsilon & \text{if } x \leq 3 \\ 7 \otimes 3^j & \text{if } 4 \otimes 3^j \leq x < 7 \otimes 3^j \text{ with } j \in \mathbb{N}_0 \\ \top & \text{if } x = \top \end{cases}$$

is a causal periodic series in  $\mathcal{F}_{\overline{\mathbb{N}}_{\max}, \gamma}[\gamma]$  drawn in Fig. 4.3.

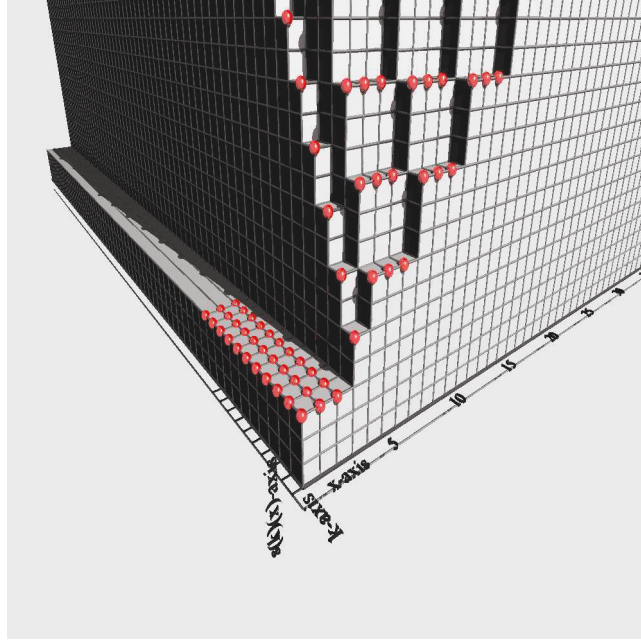

Figure 4.3.: Series  $s = f_1 \oplus (\Delta^2 \gamma)^* f_2 \oplus (\Delta^3 \gamma)^* f_3$ .

#### 4.3.1. Canonical Representative of Periodic Series

In this section, a canonical representative for periodic series in  $\mathcal{F}_{\bar{\mathbb{N}}_{\max}, \gamma}[\gamma]$  is introduced based on the associated mapping  $\psi(s)$  in  $\mathcal{F}_R(\bar{\mathbb{N}}_{\max}, \bar{\mathbb{N}}_{\max, \gamma}[\gamma])$ . The main idea is to use the existing canonical representative for periodic series in  $\bar{\mathbb{N}}_{\max, \gamma}[\gamma]$  introduced in [22, 23]. First, the effect of the periodicity of series  $s$  on the mapping  $\psi(s)$  is investigated in the following lemma.

**Lemma 38.** *Let  $s$  be a series in  $\mathcal{F}_{\bar{\mathbb{N}}_{\max}, \gamma}[\gamma]$ . If  $s$  is periodic, then*

$$\left\{ \begin{array}{l} \forall x \in \bar{\mathbb{N}}_{\max}, \psi(s)(x) \text{ is a periodic series in } \bar{\mathbb{N}}_{\max, \gamma}[\gamma] \\ \exists X \in \mathbb{N}_0, \exists \omega \in \mathbb{N} \text{ such that } \forall x \geq X, \psi(s)(\omega x) = \omega \psi(s)(x) \end{array} \right.$$

*Proof.* There exist  $N \in \mathbb{N}$ , periodic mappings  $f_1, \dots, f_N$  in  $\mathcal{F}_{\bar{\mathbb{N}}_{\max}}$ ,  $n_1, \dots, n_N$  in  $\mathbb{N}_0$ ,  $\tau_1, \dots, \tau_N$  in  $\mathbb{N}_0$ , and  $\nu$  in  $\mathbb{N}$  such that

$$s = \bigoplus_{k=1}^N (\Delta^{\tau_k} \gamma^\nu)^* f_k \gamma^{n_k}$$

As  $\psi$  is residuated,  $\psi$  is lower semi-continuous. Hence,

$$\forall x \in \bar{\mathbb{N}}_{\max}, \quad \psi(s)(x) = \bigoplus_{k=1}^N \psi((\Delta^{\tau_k \gamma^\nu})^* f_k \gamma^{n_k})(x)$$

According to Prop. 11, to prove the periodicity of  $\psi(s)(x)$ , it is sufficient to prove the periodicity of  $\psi((\Delta^{\tau_k \gamma^\nu})^* f_k \gamma^{n_k})(x)$ . As  $\psi$  is lower semi-continuous, Rem. 12 leads to

$$\begin{aligned} \forall x \in \bar{\mathbb{N}}_{\max}, \quad \psi((\Delta^{\tau_k \gamma^\nu})^* f_k \gamma^{n_k})(x) &= \bigoplus_{j=0}^{+\infty} \psi(\Delta^{j \tau_k \gamma^{j\nu}} f_k \gamma^{n_k})(x) \\ &= \bigoplus_{j=0}^{+\infty} \tau_k^j \gamma^{j\nu} \psi(f_k \gamma^{n_k})(x) \\ &= (\tau_k \gamma^\nu)^* \psi(f_k \gamma^{n_k})(x) \\ &= (\tau_k \gamma^\nu)^* f_k(x) \gamma^{n_k} \end{aligned}$$

Then,  $\psi((\Delta^{\tau_k \gamma^\nu})^* f_k \gamma^{n_k})(x)$  is a periodic series in  $\bar{\mathbb{N}}_{\max, \gamma}[\gamma]$ . Consequently,  $\psi(s)(x)$  is a periodic series in  $\bar{\mathbb{N}}_{\max, \gamma}[\gamma]$ . Furthermore, the mapping  $f_k$  is a periodic mapping in  $\mathcal{F}_{\bar{\mathbb{N}}_{\max}}$ : there exist  $X_k \in \mathbb{N}_0$  and  $\omega_k \in \mathbb{N}$  such that

$$\forall x \geq X_k, \quad f_k(\omega_k x) = \omega_k f_k(x)$$

Let  $X = \bigoplus_{k=1}^N X_k$  and  $\omega = \text{lcm}(\omega_1, \dots, \omega_N)$ . Then,

$$\begin{aligned} \forall x \geq X, \quad \psi((\Delta^{\tau_k \gamma^\nu})^* f_k \gamma^{n_k})(\omega x) &= (\tau_k \gamma^\nu)^* f_k(\omega x) \gamma^{n_k} \\ &= \omega (\tau_k \gamma^\nu)^* f_k(x) \gamma^{n_k} \\ &= \omega \psi((\Delta^{\tau_k \gamma^\nu})^* f_k \gamma^{n_k})(x) \end{aligned}$$

Thus,

$$\begin{aligned} \forall x \geq X, \quad \psi(s)(\omega x) &= \bigoplus_{k=1}^N \psi((\Delta^{\tau_k \gamma^\nu})^* f_k \gamma^{n_k})(\omega x) \\ &= \bigoplus_{k=1}^N \omega \psi((\Delta^{\tau_k \gamma^\nu})^* f_k \gamma^{n_k})(x) \\ &= \omega \psi(s)(x) \end{aligned}$$

□

This leads to a unique representative in  $\mathcal{F}_R(\bar{\mathbb{N}}_{\max}, \bar{\mathbb{N}}_{\max, \gamma}[\gamma])$  of a periodic series  $s$  in  $\mathcal{F}_{\bar{\mathbb{N}}_{\max, \gamma}[\gamma]}$  obtained from  $\psi(s)$  by, first, minimizing  $\omega$  and, second, minimizing  $X$ . In the following, a canonical representative of  $s$  is derived from  $\psi(s)$ . If  $\psi(s) = \varepsilon$ , then the

canonical representative of  $s$  is  $\varepsilon$ . Next, the case  $s \neq \varepsilon$  is investigated. There exists  $Y_0 \in \mathbb{N}_0$  such that  $\psi(s)(Y_0 \neq 1) = \varepsilon$  and  $\psi(s)(Y_0) \neq \varepsilon$ . The mapping  $\Sigma_s$  from  $\{x \in \overline{\mathbb{N}}_{\max} | x \geq Y_0\}$  to  $\mathbb{Q} \cup \{+\infty\}$  is defined by

$$\Sigma_s(x) = \sigma(\psi(s)(x))$$

As  $s$  is a non-zero periodic series  $s$ ,  $\psi(s)(\top) = \top \gamma^{\text{val}(s)}$  and  $\Sigma_s(\top) = 0$ .

**Lemma 39.** *Let  $s$  be a non-zero periodic series. The mapping  $\Sigma_s$  is non-increasing.*

*Proof.* Let  $x_1, x_2 \in \overline{\mathbb{N}}_{\max}$  greater than or equal to  $Y_0$ . Then,  $\psi(s)(x_1)$  and  $\psi(s)(x_2)$  are different from  $\varepsilon$ . Furthermore,

$$\begin{aligned} x_1 \geq x_2 &\Rightarrow \psi(s)(x_1) \geq \psi(s)(x_2) \text{ as } \psi(s) \text{ is isotone} \\ &\Rightarrow \psi(s)(x_1) = \psi(s)(x_1) \oplus \psi(s)(x_2) \\ &\Rightarrow \sigma(\psi(s)(x_1)) = \min(\sigma(\psi(s)(x_1)), \sigma(\psi(s)(x_2))) \text{ see Prop. 11} \\ &\Rightarrow \sigma(\psi(s)(x_1)) \leq \sigma(\psi(s)(x_2)) \\ &\Rightarrow \Sigma_s(x_1) \leq \Sigma_s(x_2) \end{aligned}$$

□

**Lemma 40.** *Let  $s$  be a non-zero periodic series in  $\mathcal{F}_{\overline{\mathbb{N}}_{\max, \gamma}}[\gamma]$ . There exists  $X \in \mathbb{N}_0$  such that, for all  $x \in \mathbb{N}_0$ , with  $x \geq X$ ,  $\Sigma_s(x) = \Sigma_s(X)$ . Furthermore, a possible choice for  $X$  is given in Lem. 38.*

*Proof.* According to Lem. 38, there exist  $X \in \mathbb{N}_0$  and  $\omega \in \mathbb{N}$  such that,  $\forall x \geq X$ ,  $\psi(s)(\omega x) = \omega \psi(s)(x)$ . For  $x \in \mathbb{N}_0$ , such that  $x \geq X$ ,  $x = \omega^k x'$  with  $k \in \mathbb{N}_0$  and  $X \leq x' < \omega X$ . Then,  $\psi(s)(x) = \omega^k \psi(s)(x')$ . This implies  $\Sigma_s(x) = \Sigma_s(x')$ . Furthermore, as  $\psi(s)$  is isotone,

$$\psi(s)(X) \leq \psi(s)(x') \leq \psi(s)(\omega X) = \omega \psi(s)(X)$$

Therefore,  $\Sigma_s(x) = \Sigma_s(x') = \Sigma_s(X)$ .

□

According to Lem. 39 and Lem. 40, there exist  $Y_0, \dots, Y_L$  in  $\mathbb{Z}$  such that

$$\begin{cases} \psi(s)(Y_0) \neq \varepsilon \text{ and } \psi(s)(Y_0 \neq 1) = \varepsilon \\ \sigma(\psi(s)(Y_{i-1})) = \sigma(\psi(s)(Y_i \neq 1)) > \sigma(\psi(s)(Y_i)) \text{ with } 1 \leq i \leq L \\ \forall x, \text{ such that } \top > x \geq Y_L, \quad \sigma(\psi(s)(x)) = \sigma(\psi(s)(Y_L)) \end{cases}$$

By convention, we set  $Y_{L+1}$  to  $\top$ . The canonical representative of  $\psi(s)(x)$  for  $x \geq Y_0$  is denoted  $p_x \oplus q_x (\tau_x \gamma^{y_x})^*$ . According to Lem. 38, there exist  $X \in \mathbb{N}_0$  and  $\omega \in \mathbb{N}$  such that

$$\forall x \geq X, \quad \psi(s)(\omega x) = \omega \psi(s)(x)$$



Then,

$$M = \max_{x \geq Y_0} a_x = \max_{\omega X > x \geq Y_0} a_x \text{ where } a_x = \begin{cases} -\infty & \text{if } p_x = \varepsilon \text{ and } q_x = \varepsilon \\ \deg(p_x) + 1 & \text{if } q_x = \varepsilon \text{ and } p_x \neq \varepsilon \\ \text{val}(q_x) & \text{if } q_x \neq \varepsilon \end{cases}$$

$$v' = \text{lcm}_{x \geq Y_0} v_x = \text{lcm}_{\omega X > x \geq Y_0} v_x$$

$$v'_i = \max_{Y_{i+1} \wedge \omega X > x \geq Y_i} v_x \text{ with } 0 \leq i \leq L$$

$$\tau'_i = \frac{v'}{v'_i} \left( \max_{Y_{i+1} \wedge \omega X > x \geq Y_i} \tau_x \right) \text{ with } 0 \leq i \leq L$$

For all  $x$ , such that  $Y_{i+1} > x \geq Y_i$ ,  $\psi(s)(x)$  admits a representative  $\tilde{p}_x \oplus \tilde{q}_x \left( \tau'_i \gamma^{v'} \right)^*$  with  $\text{val}(\tilde{q}_x) = M$  obtained by developing the Kleene star. Furthermore,

$$m = \min_{x \geq Y_0} \text{val}(\tilde{p}_x) = \min_{\omega X > x \geq Y_0} \text{val}(\tilde{p}_x)$$

Polynomials  $\tilde{p}_x$  and  $\tilde{q}_x$  admit the following non-canonical representatives:

$$\tilde{p}_x = \begin{cases} \varepsilon & \text{if } m = +\infty \\ \bigoplus_{l=m}^{M-1} s(l)(x) \gamma^l & \text{otherwise} \end{cases} \quad \text{and } \tilde{q}_x = \bigoplus_{l=M}^{M+v'-1} s(l)(x) \gamma^l$$

The polynomials  $p, q_0, \dots, q_L$  in  $\mathcal{F}_{\bar{\mathbb{N}}_{\max}, \gamma}[\gamma]$  are defined by

$$p = \begin{cases} \varepsilon & \text{if } m = +\infty \\ \bigoplus_{l=m}^{M-1} s(l) \gamma^l & \text{otherwise} \end{cases}$$

$$q_k = \bigoplus_{l=M}^{M+v'-1} f_{q_k, l} \gamma^l \text{ with } f_{q_k, l}(x) = \begin{cases} \varepsilon & \text{if } x < Y_k \\ s(l)(x) & \text{if } x \geq Y_k \end{cases}$$

As  $s$  is a periodic series,  $s(l)$  with  $l \in \mathbb{Z}$  is a periodic mapping in  $\mathcal{F}_{\bar{\mathbb{N}}_{\max}}$ . Then,  $p$  and  $q_k$  are polynomials in  $\mathcal{F}_{\bar{\mathbb{N}}_{\max}, \gamma}[\gamma]$  with periodic coefficients. Therefore,  $s' = p \oplus \bigoplus_{k=0}^L \left( \Delta^{\tau'_k} \gamma^{v'} \right)^* q_k$  is a periodic series in  $\mathcal{F}_{\bar{\mathbb{N}}_{\max}, \gamma}[\gamma]$ .

$$\forall x \in \bar{\mathbb{N}}_{\max}, \quad \psi(s')(x) = \psi(p)(x) \oplus \bigoplus_{k=0}^L \left( \tau'_k \gamma^{v'} \right)^* \psi(q_k)(x)$$

If  $m = +\infty$ ,  $\psi(p)(x) = \varepsilon = \tilde{p}_x$ . Otherwise,

$$\begin{aligned} \forall x \in \bar{\mathbb{N}}_{\max}, \quad \psi(p)(x) &= \bigoplus_{l=m}^{M-1} s(l)(x) \gamma^l \\ &= \tilde{p}_x \end{aligned}$$

Therefore,

$$\forall x \in \overline{\mathbb{N}}_{\max}, \quad \psi(s')(x) = \tilde{p}_x \oplus \bigoplus_{k=0}^L (\tau'_k \gamma^{\nu'})^* \psi(q_k)(x)$$

If  $x < Y_0$ ,  $\psi(s')(x) = \varepsilon = \psi(s)(x)$ . If  $Y_i \leq x < Y_{i+1}$ ,

$$\begin{aligned} \psi(s')(x) &= \tilde{p}_x \oplus \bigoplus_{k=0}^i (\tau'_k \gamma^{\nu'})^* \psi(q_k)(x) \\ &= \tilde{p}_x \oplus \bigoplus_{k=0}^i (\tau'_k \gamma^{\nu'})^* \left( \bigoplus_{l=M}^{M+\nu'-1} s(l)(x) \gamma^l \right) \\ &= \tilde{p}_x \oplus \bigoplus_{k=0}^i (\tau'_k \gamma^{\nu'})^* \tilde{q}_x \\ &= \tilde{p}_x \oplus \tilde{q}_x (\tau'_i \gamma^{\nu'})^* \\ &= \psi(s)(x) \end{aligned}$$

Furthermore,  $\psi(s)(\top) = \psi(s')(\top)$  comes from the lower semi-continuity of  $\psi(s)$  and  $\psi(s')$ . Then,  $s = s'$  as  $\psi$  is injective. The canonical representative of  $s$  is

$$s = p \oplus \bigoplus_{k=0}^L (\Delta \tau'_k \gamma^{\nu'})^* q_k$$

where the canonical representatives of polynomials  $p, q_0, \dots, q_L$  are considered.

**Example 20.** For the periodic series  $s$  defined in Ex. 19,

$$\psi(s)(x) = \begin{cases} \varepsilon & \text{if } x = \varepsilon \\ 3 & \text{if } x = 0, 1, 2 \\ 5(2\gamma)^* & \text{if } x = 3 \\ 3^j \otimes 7(3\gamma)^* & \text{if } 4 \otimes 3^j \leq x < 7 \otimes 3^j \text{ with } j \in \mathbb{N}_0 \\ \top & \text{if } x = \top \end{cases}$$

Then,  $Y_0 = 0$  and

$$\Sigma_s(x) = \begin{cases} +\infty & \text{if } x = 0, 1, 2 \\ \frac{1}{2} & \text{if } x = 3 \\ \frac{1}{3} & \text{if } 4 \leq x < \top \\ 0 & \text{if } x = \top \end{cases}$$

The canonical representative of  $s$  is  $f_1 \oplus (\Delta^2\gamma)^* f_2\gamma \oplus (\Delta^3\gamma)^* f_3\gamma$  with

$$f_1(x) = \begin{cases} \varepsilon & \text{if } x = \varepsilon \\ 3 & \text{if } x = 0, 1, 2 \\ 5 & \text{if } x = 3 \\ 7 \otimes 3^j & \text{if } 4 \otimes 3^j \leq x < 7 \otimes 3^j \text{ with } j \in \mathbb{N}_0 \\ \top & \text{if } x = \top \end{cases}$$

$$f_2(x) = \begin{cases} \varepsilon & \text{if } x < 3 \\ 7 & \text{if } x = 3 \\ 10 \otimes 3^j & \text{if } 4 \otimes 3^j \leq x < 7 \otimes 3^j \text{ with } j \in \mathbb{N}_0 \\ \top & \text{if } x = \top \end{cases}$$

$$f_3(x) = \begin{cases} \varepsilon & \text{if } x < 4 \\ 10 \otimes 3^j & \text{if } 4 \otimes 3^j \leq x < 7 \otimes 3^j \text{ with } j \in \mathbb{N}_0 \\ \top & \text{if } x = \top \end{cases}$$

### Throughput

Lem. 39 and Lem. 40 allow us to extend the notion of throughput to periodic series in  $\mathcal{F}_{\overline{\mathbb{N}}_{\max}, \gamma}[\llbracket \gamma \rrbracket]$ .

**Definition 43** (Throughput). *Let  $s$  be a non-zero periodic series in  $\mathcal{F}_{\overline{\mathbb{N}}_{\max}, \gamma}[\llbracket \gamma \rrbracket]$ . The throughput of  $s$ , denoted  $\sigma(s)$ , is  $\Sigma_s(X)$  with  $X \in \mathbb{N}_0$  such that  $\Sigma_s(X) = \Sigma_s(x)$  for  $x \in \mathbb{N}_0$  greater than or equal to  $X$ .*

**Example 21.** *For the periodic series  $s$  defined in Ex. 19,*

$$\sigma(s) = \Sigma_s(4) = \frac{1}{3}$$

### Quasi-Causal Periodic Series

The following proposition provides a characterization of quasi-causality for periodic series.

**Proposition 27.** *Let  $s$  be a periodic series in  $\mathcal{F}_{\overline{\mathbb{N}}_{\max}, \gamma}[\llbracket \gamma \rrbracket]$  with the canonical representative  $p \oplus \bigoplus_{k=0}^L (\Delta^{\tau_k} \gamma^v)^* q_k$ . The following statements are equivalent:*

1.  $s$  is a quasi-causal series
2.  $p, q_0, \dots, q_L$  are quasi-causal polynomials

#### 4. Dioid $\mathcal{F}_{\overline{\mathbb{N}}_{\max, \gamma}}[[\gamma]]$

---

*Proof.* 1  $\Rightarrow$  2: If  $m = +\infty$ ,  $p = \varepsilon$  is a quasi-causal polynomial. Otherwise,

$$\forall l \in \mathbb{Z}, \quad p(l) = \begin{cases} \varepsilon & \text{if } l < m \\ s(l) & \text{if } m \leq l < M \\ s(M-1) & \text{if } l \geq M \end{cases}$$

As  $s$  is a quasi-causal series,  $p$  is a quasi-causal polynomial. Furthermore,

$$\forall l \in \mathbb{Z}, \quad q_k(l) = \begin{cases} \varepsilon & \text{if } l < M \\ f_{q_k, l} & \text{if } M+1 \leq l < M+\gamma \\ f_{q_k, M+\gamma-1} & \text{if } l \geq M+\gamma \end{cases}$$

with

$$f_{q_k, l}(x) = \begin{cases} \varepsilon & \text{if } x < Y_k \\ s(l)(x) & \text{if } x \geq Y_k \end{cases}$$

Mapping  $f_{q_k, l}$  is quasi-causal, as  $s$  is quasi-causal. Then,  $q_k$  is a quasi-causal polynomial.

2  $\Rightarrow$  1: For  $l \in \mathbb{Z}$ ,

$$s(l) = \begin{cases} p(l) & \text{if } l < M \\ p(l) \oplus \bigoplus_{k=0}^l \Delta^{l - \lfloor \frac{l-M}{\gamma} \rfloor \tau_k} q_k(l - \lfloor \frac{l-M}{\gamma} \rfloor \gamma) & \text{if } l \geq M \end{cases}$$

Therefore,  $s$  is quasi-causal. □

#### 4.3.2. Calculation with Periodic Series

Next, the behavior of periodic series with respect to operations  $\oplus$ ,  $\otimes$ ,  $\wedge$ ,  $\bowtie$ , and  $\phi$  is investigated.

**Proposition 28** (Sum of periodic series). *Let  $s_1$  and  $s_2$  be two periodic series in  $\mathcal{F}_{\overline{\mathbb{N}}_{\max, \gamma}}[[\gamma]]$ . Series  $s_1 \oplus s_2$  is periodic. If  $s_1$  and  $s_2$  are different from  $\varepsilon$ , then*

$$\sigma(s_1 \oplus s_2) = \min(\sigma(s_1), \sigma(s_2))$$

*Proof.* See § A.1.1. □

**Proposition 29** (Greatest lower bound of periodic series). *Let  $s_1$  and  $s_2$  be two periodic series in  $\mathcal{F}_{\overline{\mathbb{N}}_{\max, \gamma}}[[\gamma]]$ . Series  $s_1 \wedge s_2$  is periodic. If  $s_1$  and  $s_2$  are different from  $\varepsilon$ , then*

$$\sigma(s_1 \wedge s_2) = \max(\sigma(s_1), \sigma(s_2))$$

*Proof.* See § A.1.2. □

**Proposition 30** (Product of periodic series). *Let  $s_1$  and  $s_2$  be two periodic series in  $\mathcal{F}_{\overline{\mathbb{N}}_{\max}, \gamma} \llbracket \gamma \rrbracket$ . Series  $s_1 \otimes s_2$  is periodic. If  $s_1$  and  $s_2$  are different from  $\varepsilon$ , then*

$$\sigma(s_1 \otimes s_2) = \min(\sigma(s_1), \sigma(s_2))$$

*Proof.* See § A.1.3. □

**Remark 13.** *According to Prop. 28 and Prop. 30, the set of periodic series in  $\mathcal{F}_{\overline{\mathbb{N}}_{\max}, \gamma} \llbracket \gamma \rrbracket$  is a subdioid of  $\mathcal{F}_{\overline{\mathbb{N}}_{\max}, \gamma} \llbracket \gamma \rrbracket$ , denoted  $\mathcal{F}_{\overline{\mathbb{N}}_{\max}, \gamma}^{\text{per}} \llbracket \gamma \rrbracket$ . However,  $\mathcal{F}_{\overline{\mathbb{N}}_{\max}, \gamma}^{\text{per}} \llbracket \gamma \rrbracket$  is not complete. But, the operation  $\wedge$  is well-defined on  $\mathcal{F}_{\overline{\mathbb{N}}_{\max}, \gamma}^{\text{per}} \llbracket \gamma \rrbracket$  according to Prop. 29.*

**Proposition 31** (Left-division of quasi-causal periodic series). *Let  $s_1, s_2$  be two quasi-causal periodic series in  $\mathcal{F}_{\overline{\mathbb{N}}_{\max}, \gamma} \llbracket \gamma \rrbracket$ . Series  $s_1 \dot{\setminus}_+ s_2$  is periodic. If  $s_1$  and  $s_2$  are different from  $\varepsilon$ ,*

- *if  $\sigma(s_1) < \sigma(s_2)$ , then  $s_1 \dot{\setminus}_+ s_2 = \varepsilon$*
- *if  $\sigma(s_1) = \sigma(s_2) = +\infty$ , then  $s_1 \dot{\setminus}_+ s_2$  is either equal to  $\varepsilon$  or  $\sigma(s_1 \dot{\setminus}_+ s_2) = +\infty$*
- *if  $\sigma(s_2) \neq +\infty$  and  $\sigma(s_1) \geq \sigma(s_2)$ , then  $\sigma(s_1 \dot{\setminus}_+ s_2) = \sigma(s_2)$*

*Proof.* See § A.1.4. □

**Proposition 32** (Kleene star of causal periodic series). *The Kleene star of a causal periodic series is a causal periodic series.*

*Proof.* See § A.1.5. □

**Remark 14.** *A direct consequence of the previous proposition is that the dioid of causal periodic series  $\mathcal{F}_{\overline{\mathbb{N}}_{\max}, \gamma}^{+, \text{per}} \llbracket \gamma \rrbracket$  is rationally closed. However, this dioid is not complete.*

The last operation to investigate is the right-division. The set of quasi-causal series in  $\mathcal{F}_{\overline{\mathbb{N}}_{\max}, \gamma} \llbracket \gamma \rrbracket$  is a complete dioid. Therefore, the product is residuated.  $s_2 \dot{\setminus}_+ s_1$  is the greatest quasi-causal series  $s$  such that  $s \otimes s_1 \leq s_2$ . However, the periodicity of  $s_2 \dot{\setminus}_+ s_1$  is not ensured as shown in the next example.

**Example 22.** *Let us consider  $s_1 = (\Delta\gamma^2)^*$  and  $s_2 = (\Delta\gamma)^* f$  with*

$$f(x) = \begin{cases} \varepsilon & \text{if } x = \varepsilon \\ e & \text{if } x = e \\ \top & \text{otherwise} \end{cases}$$

*According to (2.3),*

$$s_2 \dot{\setminus}_+ s_1 = \bigwedge_{j \geq 0} s_2 \dot{\setminus}_+ (\Delta^j \gamma^{2j})$$

4. Dioid  $\mathcal{F}_{\overline{\mathbb{N}}_{\max}, \gamma}[\gamma]$

---

Then, according to (2.11),

$$\begin{aligned} \forall l \in \mathbb{Z}, \quad (s_2^{\beta_+} s_1)(l) &= \bigwedge_{j \geq 0} \left( s_2^{\beta_+} \left( \Delta^j \gamma^{2j} \right) \right) (l) \\ &= \bigwedge_{j \geq 0} s_2(l + 2j)^{\beta_+ \Delta^j} \end{aligned}$$

By definition,  $(s_2^{\beta_+} s_1)(l) = \varepsilon$  if  $l < 0$ . Otherwise,

$$\forall l \in \mathbb{N}_0, \quad (s_2^{\beta_+} s_1)(l) = \bigwedge_{j \geq 0} \text{Pr}_+ \left( \Delta^{l+2j} f \left( \Delta^j \right)^{\beta} \right)$$

As  $f \geq \text{Id}$ ,

$$\Delta^{l+2j} f \left( \Delta^j \right)^{\beta} \geq \Delta^{l+2j} \left( \Delta^j \right)^{\beta} \geq \Delta^{l+j} \geq \text{Id}$$

Thus,

$$\forall l \in \mathbb{N}_0, \quad (s_2^{\beta_+} s_1)(l) = \bigwedge_{j \geq 0} F_j \text{ with } F_j = \Delta^{l+2j} f \left( \Delta^j \right)^{\beta}$$

Clearly,

$$F_j(x) = \begin{cases} \varepsilon & \text{if } x = \varepsilon \\ lj^2 & \text{if } e \leq x \leq j \\ \top & \text{if } x > j \end{cases}$$

Then,

$$\begin{aligned} \forall l \in \mathbb{N}_0, \forall x \in \mathbb{N}_0, \quad (s_2^{\beta_+} s_1)(l)(x) &= \bigwedge_{j \geq 0} F_j(x) \\ &= lx^2 \end{aligned}$$

Thus,

$$\forall l \in \mathbb{N}_0, \quad (s_2^{\beta_+} s_1)(l) = ((\Delta\gamma)^* g)(l) \text{ with } g(x) = x^2$$

Then,

$$s_2^{\beta_+} s_1 = (\Delta\gamma)^* g$$

Therefore,  $s_2^{\beta_+} s_1$  is not a periodic series in  $\mathcal{F}_{\overline{\mathbb{N}}_{\max}, \gamma}[\gamma]$ , as  $g$  is not a periodic mapping in  $\mathcal{F}_{\overline{\mathbb{N}}_{\max}}$ .

### 4.3.3. Subdioid $\mathcal{F}_{\overline{\mathbb{N}}_{\max, \gamma}}^{\text{per}, c}[\gamma]$

In the following, we restrain ourselves to a subdioid of causal periodic series, denoted  $\mathcal{F}_{\overline{\mathbb{N}}_{\max, \gamma}}^{\text{per}, c}[\gamma]$ , which is closed with respect to the right-division.

**Definition 44.** *The subset  $\mathcal{F}_{\overline{\mathbb{N}}_{\max, \gamma}}^{\text{per}, c}[\gamma]$  of  $\mathcal{F}_{\overline{\mathbb{N}}_{\max, \gamma}}^{\text{per}}[\gamma]$  is defined as*

$$\mathcal{F}_{\overline{\mathbb{N}}_{\max, \gamma}}^{\text{per}, c}[\gamma] = \{\varepsilon\} \cup \left\{ s \in \mathcal{F}_{\overline{\mathbb{N}}_{\max, \gamma}}^{\text{per}}[\gamma] \mid \sigma(s) = \sigma(\psi(s)(e)) \text{ and } s \text{ is causal} \right\}$$

#### Canonical Representative of Series in $\mathcal{F}_{\overline{\mathbb{N}}_{\max, \gamma}}^{\text{per}, c}[\gamma]$

A series  $s$  in  $\mathcal{F}_{\overline{\mathbb{N}}_{\max, \gamma}}^{\text{per}, c}[\gamma]$  is a periodic series in  $\mathcal{F}_{\overline{\mathbb{N}}_{\max, \gamma}}^{\text{per}}[\gamma]$ . Therefore, a canonical representative for  $s$  is available in § 4.3.1. In the following, particular properties of the canonical representative of a series  $s$  in  $\mathcal{F}_{\overline{\mathbb{N}}_{\max, \gamma}}^{\text{per}, c}[\gamma]$  are discussed depending on the value of  $\sigma(s)$ .

$\sigma(s) = +\infty$ :  $s$  is a polynomial with the canonical representative

$$s = \bigoplus_{k=1}^N f_k \gamma^{n_k} \text{ with } n_1 < \dots < n_N \text{ and } f_k(x) \neq \top \text{ for } x \neq \top$$

$\sigma(s) = 0$ :  $s$  is a polynomial with the canonical representative

$$s = \bigoplus_{k=1}^N f_k \gamma^{n_k} \text{ with } n_1 < \dots < n_N \text{ and } f_N = \top$$

$0 < \sigma(s) < +\infty$ : The canonical representative of  $s$  has the following form

$$s = p \oplus (\Delta^\tau \gamma^\nu)^* q$$

with  $\tau, \nu$  in  $\mathbb{N}$  and causal polynomials  $p, q$  in  $\mathcal{F}_{\overline{\mathbb{N}}_{\max, \gamma}}^{++}[\gamma]$ . Furthermore,  $\sigma(s) = \frac{\nu}{\tau}$ ,  $p = \varepsilon$  or  $\sigma(p) = +\infty$ , and  $\sigma(q) = +\infty$ .

#### Calculation with Series in $\mathcal{F}_{\overline{\mathbb{N}}_{\max, \gamma}}^{\text{per}, c}[\gamma]$

Next, the behavior of series in  $\mathcal{F}_{\overline{\mathbb{N}}_{\max, \gamma}}^{\text{per}, c}[\gamma]$  with respect to operations  $\oplus$ ,  $\otimes$ ,  $\wedge$ ,  $\flat$ , and  $\phi$  defined on  $\mathcal{F}_{\overline{\mathbb{N}}_{\max, \gamma}}[\gamma]$  is investigated.

**Proposition 33** (Sum of series in  $\mathcal{F}_{\overline{\mathbb{N}}_{\max, \gamma}}^{\text{per}, c}[\gamma]$ ). *Let  $s_1$  and  $s_2$  be two series in  $\mathcal{F}_{\overline{\mathbb{N}}_{\max, \gamma}}^{\text{per}, c}[\gamma]$ . Series  $s_1 \oplus s_2$  belongs to  $\mathcal{F}_{\overline{\mathbb{N}}_{\max, \gamma}}^{\text{per}, c}[\gamma]$ . If  $s_1$  and  $s_2$  are different from  $\varepsilon$ , then*

$$\sigma(s_1 \oplus s_2) = \min(\sigma(s_1), \sigma(s_2))$$

#### 4. Dioid $\mathcal{F}_{\overline{\mathbb{N}}_{\max}, \gamma} \llbracket \gamma \rrbracket$

---

*Proof.* See § A.2.1. □

**Proposition 34** (Greatest lower bound of series in  $\mathcal{F}_{\overline{\mathbb{N}}_{\max}, \gamma}^{\text{per}, c} \llbracket \gamma \rrbracket$ ). *Let  $s_1$  and  $s_2$  be two series in  $\mathcal{F}_{\overline{\mathbb{N}}_{\max}, \gamma}^{\text{per}, c} \llbracket \gamma \rrbracket$ . Series  $s_1 \wedge s_2$  belongs to  $\mathcal{F}_{\overline{\mathbb{N}}_{\max}, \gamma}^{\text{per}, c} \llbracket \gamma \rrbracket$ . If  $s_1$  and  $s_2$  are different from  $\varepsilon$ , then*

$$\sigma(s_1 \wedge s_2) = \max(\sigma(s_1), \sigma(s_2))$$

*Proof.* See § A.2.2. □

**Proposition 35** (Product of series in  $\mathcal{F}_{\overline{\mathbb{N}}_{\max}, \gamma}^{\text{per}, c} \llbracket \gamma \rrbracket$ ). *Let  $s_1$  and  $s_2$  be two series in  $\mathcal{F}_{\overline{\mathbb{N}}_{\max}, \gamma}^{\text{per}, c} \llbracket \gamma \rrbracket$ . Series  $s_1 \otimes s_2$  belongs to  $\mathcal{F}_{\overline{\mathbb{N}}_{\max}, \gamma}^{\text{per}, c} \llbracket \gamma \rrbracket$ . If  $s_1$  and  $s_2$  are different from  $\varepsilon$ , then*

$$\sigma(s_1 \otimes s_2) = \min(\sigma(s_1), \sigma(s_2))$$

*Proof.* See § A.2.3. □

**Proposition 36** (Left-division of series in  $\mathcal{F}_{\overline{\mathbb{N}}_{\max}, \gamma}^{\text{per}, c} \llbracket \gamma \rrbracket$ ). *Let  $s_1, s_2$  be two series in  $\mathcal{F}_{\overline{\mathbb{N}}_{\max}, \gamma}^{\text{per}, c} \llbracket \gamma \rrbracket$ . Series  $s_1 \backslash_{++} s_2$  belongs to  $\mathcal{F}_{\overline{\mathbb{N}}_{\max}, \gamma}^{\text{per}, c} \llbracket \gamma \rrbracket$ . If  $s_1$  and  $s_2$  are different from  $\varepsilon$ ,*

- if  $\sigma(s_1) < \sigma(s_2)$ , then  $s_1 \backslash_{++} s_2 = \varepsilon$
- if  $\sigma(s_1) = \sigma(s_2) = +\infty$ , then  $s_1 \backslash_{++} s_2$  is either equal to  $\varepsilon$  or  $\sigma(s_1 \backslash_{++} s_2) = +\infty$
- if  $\sigma(s_2) \neq +\infty$  and  $\sigma(s_1) \geq \sigma(s_2)$ , then  $\sigma(s_1 \backslash_{++} s_2) = \sigma(s_2)$

*Proof.* See § A.2.4. □

**Proposition 37** (Right-division of series in  $\mathcal{F}_{\overline{\mathbb{N}}_{\max}, \gamma}^{\text{per}, c} \llbracket \gamma \rrbracket$ ). *Let  $s_1, s_2$  be two series in  $\mathcal{F}_{\overline{\mathbb{N}}_{\max}, \gamma}^{\text{per}, c} \llbracket \gamma \rrbracket$ . Series  $s_2 \dot{\backslash}_{++} s_1$  belongs to  $\mathcal{F}_{\overline{\mathbb{N}}_{\max}, \gamma}^{\text{per}, c} \llbracket \gamma \rrbracket$ . If  $s_1$  and  $s_2$  are different from  $\varepsilon$ ,*

- if  $\sigma(s_1) < \sigma(s_2)$ , then  $s_2 \dot{\backslash}_{++} s_1 = \varepsilon$
- if  $\sigma(s_1) = \sigma(s_2) = +\infty$ , then  $s_2 \dot{\backslash}_{++} s_1$  is either equal to  $\varepsilon$  or  $\sigma(s_2 \dot{\backslash}_{++} s_1) = +\infty$
- if  $\sigma(s_2) \neq +\infty$  and  $\sigma(s_1) \geq \sigma(s_2)$ , then  $\sigma(s_2 \dot{\backslash}_{++} s_1) = \sigma(s_2)$

*Proof.* See § A.2.5. □

### 4.4. Rationality

In this section, the concept of rationality is extended from  $\mathcal{F}_{\overline{\mathbb{N}}_{\max}}$  to  $\mathcal{F}_{\overline{\mathbb{N}}_{\max}, \gamma} \llbracket \gamma \rrbracket$ .

**Definition 45** (Rationality). *A series  $s$  in  $\mathcal{F}_{\overline{\mathbb{N}}_{\max}, \gamma} \llbracket \gamma \rrbracket$  is said to be rational if there exists a finite number  $N$  of periodic series  $r_1, \dots, r_N$  in  $\overline{\mathbb{N}}_{\max, \gamma} \llbracket \gamma \rrbracket$  such that  $s$  belongs to the rational closure of  $\{\varepsilon, e, \Delta, \alpha_{r_1}, \dots, \alpha_{r_N}, \gamma\}$ .*

*A matrix with entries in  $\mathcal{F}_{\overline{\mathbb{N}}_{\max}, \gamma} \llbracket \gamma \rrbracket$  is said to be rational if all its entries are rational.*

In the following proposition, the rationality of causal periodic series is investigated based on the rationality of causal periodic mappings (see Prop. 24).



**Proposition 38.** *A causal periodic series in  $\mathcal{F}_{\overline{\mathbb{N}}_{\max}, \gamma}[\gamma]$  is rational.*

*Proof.* Let  $s$  be a causal periodic series. If  $s = \varepsilon$ ,  $s$  is rational. Otherwise,  $s$  is a non-zero causal periodic series. Then, there exists  $N \in \mathbb{N}$ , non-zero quasi-causal periodic mappings  $f_1, \dots, f_N$  in  $\mathcal{F}_{\overline{\mathbb{N}}_{\max}}$ ,  $n_1, \dots, n_N$  in  $\mathbb{N}_0$ ,  $\tau_1, \dots, \tau_N$  in  $\mathbb{N}_0$ , and  $\nu \in \mathbb{N}$  such that

$$s = \bigoplus_{k=1}^N (\Delta^{\tau_k \gamma^\nu})^* f_k \gamma^{n_k}$$

We defined  $Y_k$  by  $Y_k = \bigwedge \{x \in \overline{\mathbb{N}}_{\max} \mid f_k(x) \neq \varepsilon\}$ . As  $f_k$  is a quasi-causal mapping,  $f_k(x) \geq x$  for  $x \geq Y_k$ . In the following, the series  $\tilde{s}$  is defined by

$$\tilde{s} = \bigoplus_{k=1}^N (\mathbb{R}_k \gamma^{\nu_k})^* g_k \gamma^{n_k}$$

where

$$\mathbb{R}_k(x) = \begin{cases} x & \text{if } x < Y_k \\ \tau_k x & \text{if } x \geq Y_k \end{cases} \quad \text{and} \quad g_k(x) = \begin{cases} x & \text{if } x < Y_k \\ f_k(x) & \text{if } x \geq Y_k \end{cases}$$

As  $\mathbb{R}_k$  and  $g_k$  are causal periodic mappings in  $\mathcal{F}_{\overline{\mathbb{N}}_{\max}}$ , they are rational mappings in  $\mathcal{F}_{\overline{\mathbb{N}}_{\max}}$  according to Prop. 24. Then,  $\tilde{s}$  is a rational series. In the following, we prove that  $s = \tilde{s}$ . As  $s$  is causal,

$$\begin{aligned} \forall x \in \overline{\mathbb{N}}_{\max}, \quad \psi(s)(x) &= \bigoplus_{k=1}^N ((\tau_k \gamma^\nu)^* f_k(x) \gamma^{n_k} \oplus x \gamma^{n_k}) \\ &= \bigoplus_{k=1}^N M_k(x) \quad \text{with } M_k(x) = (\tau_k \gamma^\nu)^* f_k(x) \gamma^{n_k} \oplus x \gamma^{n_k} \end{aligned}$$

Clearly,

$$M_k(x) = \begin{cases} x \gamma^{n_k} & \text{if } x < Y_k \\ (\tau_k \gamma^\nu)^* f_k(x) \gamma^{n_k} & \text{if } x \geq Y_k \end{cases}$$

Then,  $M_k = \psi((\mathbb{R}_k \gamma^{\nu_k})^* g_k \gamma^{n_k})$ . Consequently,  $\psi(s) = \psi(\tilde{s})$ . This implies  $s = \tilde{s}$ , as  $\psi$  is injective (see Lem. 33). Thus,  $s$  is a rational series.  $\square$

## 4.5. Realizability

The concept of realizability is defined for  $\mathcal{F}_{\overline{\mathbb{N}}_{\max}, \gamma}[\gamma]$  by analogy with the realizability in  $\overline{\mathbb{N}}_{\max, \gamma}[\gamma]$ .

**Definition 46** (Realizability). *A matrix  $S$  in  $\mathcal{F}_{\overline{\mathbb{N}}_{\max, \gamma}}[\gamma]^{m \times p}$  is said to be realizable if there exists a finite number  $N$  of periodic series  $r_1, \dots, r_N$  in  $\overline{\mathbb{N}}_{\max, \gamma}[\gamma]$  such that  $S$  admits a  $(B, C)$ -representation with respect to  $\{\varepsilon, e, \Delta, \alpha_{r_1}, \dots, \alpha_{r_N}, \gamma\}$  where all non-diagonal entries of  $A$  belong to  $\{\varepsilon, e, \Delta, \gamma\}$ .*

In the following, two lemmas on realizability in  $\mathcal{F}_{\overline{\mathbb{N}}_{\max, \gamma}}[\gamma]$  are proved.

**Lemma 41.** *Let  $S$  be a matrix in  $\mathcal{F}_{\overline{\mathbb{N}}_{\max, \gamma}}[\gamma]^{m \times p}$ . The following statements are equivalent:*

1.  $S$  is realizable
2. *there exists a finite number  $N$  of periodic series  $r_1, \dots, r_N$  in  $\overline{\mathbb{N}}_{\max, \gamma}[\gamma]$  such that  $S$  admits a  $(B, C)$ -representation with respect to  $\{\varepsilon, e, \Delta, \alpha_{r_1}, \dots, \alpha_{r_N}, \gamma\}$*

*Proof.*  $1 \Rightarrow 2$  This comes directly from the definition of realizability.

$2 \Rightarrow 1$  There exists a finite number  $N$  of periodic series  $r_1, \dots, r_N$  in  $\overline{\mathbb{N}}_{\max, \gamma}[\gamma]$  such that  $S$  admits a  $(B, C)$ -representation with respect to  $\mathcal{E} = \{\varepsilon, e, \Delta, \alpha_{r_1}, \dots, \alpha_{r_N}, \gamma\}$ . Then, there exist  $n \in \mathbb{N}$ ,  $A \in \mathcal{E}^{n \times n}$ ,  $B \in \mathbb{B}^{n \times p}$ , and  $C \in \mathbb{B}^{m \times n}$  such that  $S = CA^*B$ . In the following, we show how to remove a non-diagonal entries of  $A$  equal to a  $\alpha$ -mapping, denoted  $\alpha_r$  by increasing  $n$  by 1. Let  $i, j$  with  $i \neq j$  such that  $A_{ij} = \alpha_r$ . The matrix  $\tilde{A}$  in  $\mathcal{E}^{(n+1) \times (n+1)}$  is defined by

$$\tilde{A}_{kl} = \begin{cases} \varepsilon & \text{if } k = i \text{ and } l = j \\ A_{kl} & \text{otherwise} \end{cases}$$

The matrices  $\hat{A}$  in  $\mathcal{E}^{(n+1) \times (n+1)}$ ,  $\hat{B}$  in  $\mathbb{B}^{(n+1) \times p}$ , and  $\hat{C}$  in  $\mathbb{B}^{m \times (n+1)}$  are defined by the following block representations:

$$\hat{A} = \begin{pmatrix} \tilde{A} & E_i \\ E_j^\top & \alpha_r \end{pmatrix}, \hat{B} = \begin{pmatrix} B \\ \varepsilon \end{pmatrix}, \text{ and } \hat{C} = \begin{pmatrix} C & \varepsilon \end{pmatrix}$$

where  $E_k$  denotes the vector in  $\mathbb{B}^{n \times 1}$  defined by

$$(E_k)_i = \begin{cases} e & \text{if } k = i \\ \varepsilon & \text{otherwise} \end{cases}$$

According to Lem. 10,

$$\begin{aligned} \hat{C}\hat{A}^*\hat{B} &= C \left( \tilde{A} \oplus E_i \alpha_r^* E_j^\top \right)^* B \\ &= C \left( \tilde{A} \oplus \alpha_r E_i E_j^\top \right)^* B \text{ as } \alpha_r = \alpha_r^* \text{ and } E_i \alpha_r = \alpha_r E_i \\ &= CA^*B \text{ as } \tilde{A} \oplus \alpha_r E_i E_j^\top = A \\ &= S \end{aligned}$$

Hence,  $\hat{A}$ ,  $\hat{B}$ , and  $\hat{C}$  form a (B, C)-representation with respect to  $\mathcal{E}$  of matrix S. Therefore, repeating the previous process leads to a (B, C)-representation with respect to  $\mathcal{E}$  of matrix S where all non-diagonal entries of A belong to  $\{\varepsilon, e, \Delta, \gamma\}$ .  $\square$

**Lemma 42.** *Let S be a matrix in  $\mathcal{F}_{\overline{\mathbb{N}}_{\max, \gamma}}[[\gamma]]^{m \times p}$ . The following statements are equivalent:*

1. S is realizable
2. all entries of S are realizable

*Proof.* Let us consider the following statements:

1. S is realizable
2. there exists a finite number N of periodic series  $r_1, \dots, r_N$  in  $\overline{\mathbb{N}}_{\max, \gamma}[[\gamma]]$  such that S admits a (B, C)-representation with respect to  $\{\varepsilon, e, \Delta, \alpha_{r_1}, \dots, \alpha_{r_N}, \gamma\}$
3. there exists a finite number N of periodic series  $r_1, \dots, r_N$  in  $\overline{\mathbb{N}}_{\max, \gamma}[[\gamma]]$  such that each entry of S admits a (B, C)-representation with respect to  $\{\varepsilon, e, \Delta, \alpha_{r_1}, \dots, \alpha_{r_N}, \gamma\}$
4. all entries of S are realizable

According to Lem. 41,  $1 \Leftrightarrow 2$  and  $3 \Leftrightarrow 4$ . Furthermore, according to Prop. 7,  $2 \Leftrightarrow 3$ . Hence,  $1 \Leftrightarrow 4$ .  $\square$

## 4.6. The Fundamental Theorem in $\mathcal{F}_{\overline{\mathbb{N}}_{\max, \gamma}}[[\gamma]]$

Using the definitions discussed before, the fundamental theorem in  $\overline{\mathbb{N}}_{\max, \gamma}[[\gamma]]$  is extended to  $\mathcal{F}_{\overline{\mathbb{N}}_{\max, \gamma}}[[\gamma]]$ .

**Theorem 9.** *Let S be a matrix in  $\mathcal{F}_{\overline{\mathbb{N}}_{\max, \gamma}}[[\gamma]]^{m \times p}$ . The following statements are equivalent:*

1. S is causal and periodic
2. S is rational
3. S is realizable

*Proof.* As causality, periodicity, rationality, and realizability of a matrix come down to causality, periodicity, rationality, and realizability of its entries. It is sufficient to consider the scalar case. Let s be a series in  $\mathcal{F}_{\overline{\mathbb{N}}_{\max, \gamma}}[[\gamma]]$ .

$1 \Rightarrow 2$ : s is causal and periodic, then s is rational according to Prop. 38.

$2 \Rightarrow 1$ : s is rational, then s is causal and periodic:  $\{\varepsilon, e, \Delta, \alpha_{r_1}, \dots, \alpha_{r_N}, \gamma\} \subseteq \mathcal{F}_{\overline{\mathbb{N}}_{\max, \gamma}}^{+,+, \text{per}}[[\gamma]]$

and  $\mathcal{F}_{\overline{\mathbb{N}}_{\max, \gamma}}^{+,+, \text{per}}[[\gamma]]$  is rationally closed.

$2 \Leftrightarrow 3$ : Using Th. 7 and Lem. 41, the following statements are equivalent:

1. s is rational
2. there exists a finite number N of periodic series  $r_1, \dots, r_N$  in  $\overline{\mathbb{N}}_{\max, \gamma}[[\gamma]]$  such that s belongs to the rational closure of  $\{\varepsilon, e, \Delta, \alpha_{r_1}, \dots, \alpha_{r_N}, \gamma\}$

4. Dioid  $\mathcal{F}_{\overline{\mathbb{N}}_{\max, \gamma}}[\gamma]$

---

3. there exists a finite number  $N$  of periodic series  $r_1, \dots, r_N$  in  $\overline{\mathbb{N}}_{\max, \gamma}[\gamma]$  such that  $s$  admits a (B, C)-representation with respect to  $\{\varepsilon, e, \Delta, \alpha_{r_1}, \dots, \alpha_{r_N}, \gamma\}$
4.  $s$  is realizable

□

**Part II.**

**System and Control Theory**



In this chapter, the modeling of  $(\max, +)$ -systems with partial synchronization by recursive equations in the  $(\max, +)$ -algebra is discussed. Let us first briefly recall the structure of  $(\max, +)$ -systems with partial synchronization drawn in Fig. 5.1. A  $(\max, +)$ -system with partial synchronization is split into a main system and a secondary system such that there exist only standard synchronizations between events in the same system and partial synchronization of events in the secondary system by events in the main system. The modeling of  $(\max, +)$ -systems with partial synchronization is widely based on an analogy with the modeling of timed event graphs, *e.g.*, [1]. The following results have been partly published in [18, 19]. The modeling approaches presented in this chapter are illustrated

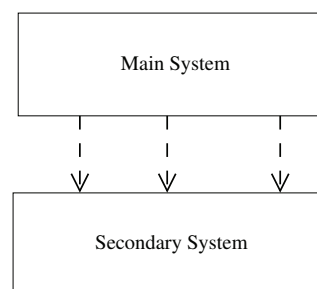

Figure 5.1.: A schematic view of a  $(\max, +)$ -system with partial synchronization

with Ex. 23.

**Example 23.** This example deals with a supply chain, where intermodal containers are shuttling back and forth between warehouses  $A_1$  and  $B_1$ . The supply chain is divided in three sections:

1. a road transport section between warehouse  $A_1$  and train station A
2. a rail transport section between train stations A and B
3. a road transport section between warehouse  $B_1$  and train station B

This system is drawn in Fig. 5.2, where the solid loop represents the train line, the dashed loops represent the road transport sections, and the dotted loop summarizes the complete supply chain. The characteristics of the train line and of the supply chain are now made explicit. Two

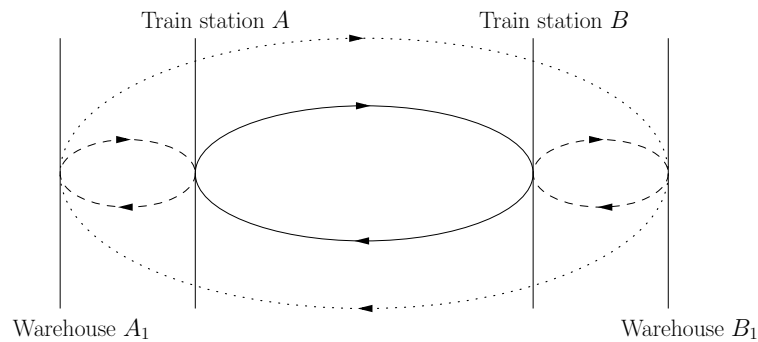

Figure 5.2.: The supply chain and the train line

trains are shuttling back and forth between train stations A and B. Initially, one train is in train station A and the other is in train station B. The travel time between train stations A and B is ten units of time. A train stays at least two units of time in a train station before returning. Due to safety practices, the number of trains on each railroad track shall not exceed one. A single container, initially in warehouse  $A_1$ , is shuttling back and forth between warehouses  $A_1$  and  $B_1$ . The duration of each road transport section (between train station A and warehouse  $A_1$  or between train station B and warehouse  $B_1$ ) is estimated to five units of time. To allow loading and unloading, the container stays at least three units of time in a warehouse before returning.

In the following, the train line and the supply chain are modeled by discrete event systems ruled by synchronization. The model of the train line is based on the following events:

$u_A$  (**resp.**  $u_B$ ) authorization for train departure from train station A (**resp.** B)

$d_A$  (**resp.**  $d_B$ ) train departure from train station A (**resp.** B)

$\alpha_A$  (**resp.**  $\alpha_B$ ) train arrival in train station A (**resp.** B)

$y_A$  (**resp.**  $y_B$ ) notification of train arrival in train station A (**resp.** B)



---

The previous description of the train line corresponds to the following synchronizations:

- for all  $k \geq 0$ , occurrence  $k$  of event  $a_A$  (resp.  $a_B$ ) is at least ten units of time after occurrence  $k$  of event  $d_B$  (resp.  $d_A$ )
- for all  $k \geq 1$ , occurrence  $k$  of event  $d_A$  (resp.  $d_B$ ) is at least two units of time after occurrence  $k - 1$  of event  $a_A$  (resp.  $a_B$ )
- for all  $k \geq 1$ , occurrence  $k$  of event  $d_A$  (resp.  $d_B$ ) is at least zero units of time after occurrence  $k - 1$  of event  $a_B$  (resp.  $a_A$ )
- for all  $k \geq 0$ , occurrence  $k$  of event  $d_A$  (resp.  $d_B$ ) is at least zero units of time after occurrence  $k$  of event  $u_A$  (resp.  $u_B$ )
- for all  $k \geq 0$ , occurrence  $k$  of event  $y_A$  (resp.  $y_B$ ) is at least zero units of time after occurrence  $k$  of event  $a_A$  (resp.  $a_B$ )

Then, the behavior of the train line is adequately expressed by standard synchronizations (i.e., the train line is a  $(\max, +)$ -linear system). The model of the supply chain is based on the following events:

- $u_{A_1}$  (**resp.**  $u_{B_1}$ ) authorization for container departure from warehouse  $A_1$  (resp.  $B_1$ )
- $d_{A_1}$  (**resp.**  $d_{B_1}$ ) container departure (by truck) from warehouse  $A_1$  (resp.  $B_1$ )
- $a_{A_1}$  (**resp.**  $a_{B_1}$ ) container arrival (by truck) in warehouse  $A_1$  (resp.  $B_1$ )
- $y_{A_1}$  (**resp.**  $y_{B_1}$ ) notification of container arrival in warehouse  $A_1$  (resp.  $B_1$ )
- $dc_A$  (**resp.**  $dc_B$ ) container departure (by train) from train station A (resp. B)
- $ac_A$  (**resp.**  $ac_B$ ) container arrival (by train) in train station A (resp. B)

The previous description of the supply chain includes the following standard synchronizations:

- for all  $k \geq 0$ , occurrence  $k$  of event  $dc_A$  (resp.  $dc_B$ ) is at least five units of time after occurrence  $k$  of event  $d_{A_1}$  (resp.  $d_{B_1}$ )
- for all  $k \geq 1$ , occurrence  $k$  of event  $d_{A_1}$  is at least three units of time after occurrence  $k - 1$  of event  $a_{A_1}$
- for all  $k \geq 0$ , occurrence  $k$  of event  $d_{B_1}$  is at least three units of time after occurrence  $k$  of event  $a_{B_1}$
- for all  $k \geq 0$ , occurrence  $k$  of event  $a_{A_1}$  (resp.  $a_{B_1}$ ) is at least five units of time after occurrence  $k$  of event  $ac_A$  (resp.  $ac_B$ )
- for all  $k \geq 0$ , occurrence  $k$  of event  $ac_A$  (resp.  $ac_B$ ) is at least ten units of time after occurrence  $k$  of event  $dc_B$  (resp.  $dc_A$ )
- for all  $k \geq 0$ , occurrence  $k$  of event  $d_{A_1}$  (resp.  $d_{B_1}$ ) is at least zero units of time after occurrence  $k$  of event  $u_{A_1}$  (resp.  $u_{B_1}$ )
- for all  $k \geq 0$ , occurrence  $k$  of event  $y_{A_1}$  (resp.  $y_{B_1}$ ) is at least zero units of time after occurrence  $k$  of event  $a_{A_1}$  (resp.  $a_{B_1}$ )

So far, the container/truck interactions (in the road transport sections) and the container/train interactions (in the rail transport section) have been neglected. While this hypothesis makes sense for the container/truck interactions (e.g., sufficiently many trucks are available to deliver containers), the container/train interactions have to be taken into account. To do so, the following partial synchronizations are used:

- event  $dc_A$  (resp.  $dc_B$ ) can only occur when event  $d_A$  (resp.  $d_B$ ) occurs
- event  $ac_A$  (resp.  $ac_B$ ) can only occur when event  $a_A$  (resp.  $a_B$ ) occurs

Therefore, the complete system is a  $(\max, +)$ -system with partial synchronization, where the main system corresponds to the train line and the secondary system corresponds to the supply chain.

## 5.1. Conventions

### 5.1.1. Input, Output, and State Events

By analogy with  $(\max, +)$ -linear systems, the event set of a  $(\max, +)$ -system with partial synchronization is partitioned into

**input events** these events are the source of (standard or partial) synchronizations, but not subject to (standard or partial) synchronizations

**output events** these events are subject to (standard or partial) synchronizations, but not the source of (standard or partial) synchronizations

**state events** these events are both subject to and the source of (standard or partial) synchronizations

Events which are neither subject to nor the source of (standard or partial) synchronizations are neglected, as we focus on interactions between events. In the rest of this thesis, we consider  $(\max, +)$ -systems with partial synchronization, where:

- the sets of input, output, and state events in the main and secondary system are not empty
- there are only partial synchronizations between state events
- there exist no direct standard synchronizations of output events by input events
- the main and the secondary system are structurally controllable: each state event is affected by at least one input event belonging to the same system
- the main and the secondary system are structurally observable: each state event affects at least one output event belonging to the same system

In practice, these assumptions either hold or can be made to hold by adding or deleting events. Furthermore, the following convention for notation is used. Parameters in the main system are denoted with subscript 1, while parameters in the secondary system are denoted with subscript 2. The numbers of input, output, and state events are respectively denoted by  $m$ ,  $p$ , and  $n$ . Input, output, and state events are respectively denoted by  $u$ ,  $y$ , and  $x$  and integer subscripts are used to distinguish events of the same kind in the main or secondary system.

**Example 24.** In Ex. 23, the set of events is partitioned into

- input events  $u_A, u_B, u_{A_1},$  and  $u_{B_1}$
- state events  $d_A, d_B, a_A, a_B, d_{A_1}, d_{B_1}, a_{A_1}, a_{B_1}, dc_A, dc_B, ac_A,$  and  $ac_B$

— output events  $y_A, y_B, y_{A_1}$ , and  $y_{B_1}$   
 These events are relabeled according to the above convention (see Tab. 5.1 and Tab. 5.2). In

$u_A$	$u_B$	$d_A$	$a_B$	$d_B$	$a_A$	$y_B$	$y_A$
$u_{1,1}$	$u_{1,2}$	$x_{1,1}$	$x_{1,2}$	$x_{1,3}$	$x_{1,4}$	$y_{1,1}$	$y_{1,2}$

Table 5.1.: Notation for events in the main system

$u_{A_1}$	$u_{B_1}$	$d_{A_1}$	$dc_A$	$ac_B$	$a_{B_1}$	$d_{B_1}$	$dc_B$	$ac_A$	$a_{A_1}$	$y_{B_1}$	$y_{A_1}$
$u_{2,1}$	$u_{2,2}$	$x_{2,1}$	$x_{2,2}$	$x_{2,3}$	$x_{2,4}$	$x_{2,5}$	$x_{2,6}$	$x_{2,7}$	$x_{2,8}$	$y_{2,1}$	$y_{2,2}$

Table 5.2.: Notation for events in the secondary system

this case,  $n_1 = 4, n_2 = 8$ , and  $m_1 = m_2 = p_1 = p_2 = 2$ .

### 5.1.2. Petri Net Representation

For the graphical representation of  $(\max, +)$ -systems with partial synchronization, the convention valid for  $(\max, +)$ -linear systems is extended to take into account partial synchronizations. Events are represented by bars. For example, the standard synchronization “for all  $k \geq 3$ , occurrence  $k$  of event  $e_2$  is at least five units of time after occurrence  $k - 3$  of event  $e_1$ ” is drawn in Fig. 5.3. Furthermore, partial synchronizations are represented

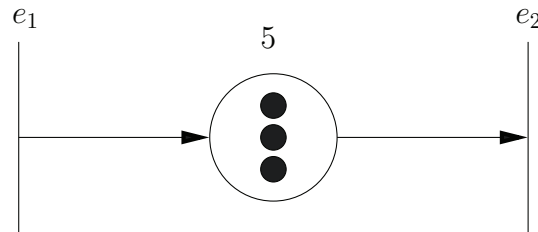

Figure 5.3.: Graphical representation of a standard synchronization

by dashed arrows. For example, the partial synchronization “event  $e_2$  can only occur *when* event  $e_1$  occurs” is drawn in Fig. 5.4. Due to visual resemblance with Petri nets, the obtained graphical representation is called Petri net representation.

**Example 25.** The Petri net representation associated with Ex. 23 is given in Fig. 5.5.



Figure 5.4.: Graphical representation of a partial synchronization

### 5.1.3. Earliest Functioning Rule

Partial and standard synchronizations only specify conditions enabling occurrences of events, but never force an event to occur. Therefore, a  $(\max, +)$ -system with partial synchronization is not deterministic: a predefined timing pattern of the input events may lead to different timing patterns for the state and output events. The only requirement is that these timing patterns are admissible with respect to standard and partial synchronizations required by the considered system.

In this thesis, we only consider a particular behavior for  $(\max, +)$ -systems with partial synchronization, namely the behavior under the earliest functioning rule. The earliest functioning rule requires that each state or output event occurs as soon as possible. Under the earliest functioning rule, a  $(\max, +)$ -system with partial synchronization is deterministic: a predefined timing pattern of the input events leads to a unique timing pattern for the state and output events. This fundamental property is formally proven in § 5.2.3.

In practice, the earliest functioning rule is often suitable, as standard and partial synchronizations express conditions on the occurrence of events. Then, as soon as the conditions are met, the associated event shall occur.

## 5.2. Dater Representation

In this section, we derive a model for  $(\max, +)$ -systems with partial synchronization based on daters. A convenient algebraic structure to express this model is the  $(\max, +)$ -algebra  $\overline{\mathbb{R}}_{\max}$ . Furthermore, we present a method based on this model to compute the output induced by a predefined input.

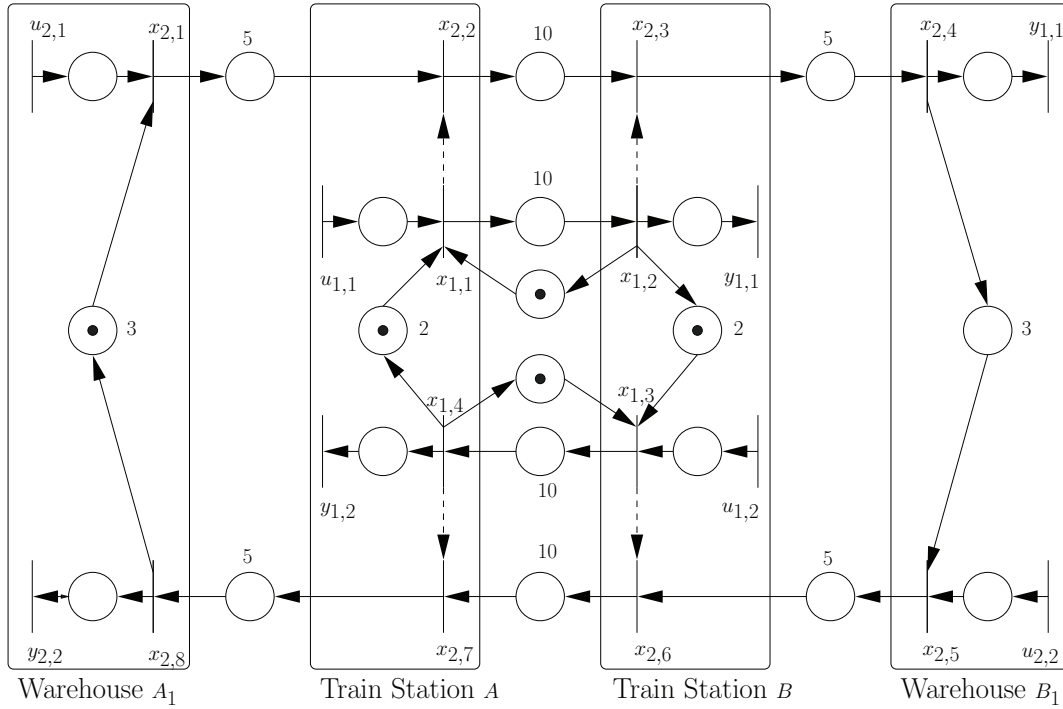

Figure 5.5.: Petri net representation of the supply chain and of the train line

### 5.2.1. Daters

To capture the timed dynamics of a discrete event system, a mapping, called dater, is associated with each event such that the dater gives the times of occurrences of the considered event. From now on, we consider daters from  $\mathbb{Z}$  to  $\overline{\mathbb{R}}_{\max}$  and no distinction in the notation is made between an event and the associated dater. Hence, for an event  $d$ ,  $d(k)$  denotes the time of occurrence  $k$  of event  $d$ . This leads to the following interpretation for daters:

$d(k) = \varepsilon$ : occurrence  $k$  of event  $d$  is at  $t = -\infty$ . By convention, occurrence  $k$  (with  $k < 0$ ) of an event always is at  $t = -\infty$ .

$d(k) \in \mathbb{R}_0^+$ : occurrence  $k$  of event  $d$  is at time  $d(k)$ . By convention, events are required to occur either at  $t \geq 0$  or at  $t = -\infty$ .

$d(k) = \top$ : occurrence  $k$  of event  $d$  never happens.

Furthermore, occurrence  $k + 1$  of event  $d$  occurs after occurrence  $k$  of event  $d$ . Therefore, as the order in  $\overline{\mathbb{R}}_{\max}$  coincides with the standard order,

$$\forall k \in \mathbb{Z}, \quad d(k+1) \geq d(k)$$

Thus, a dater is isotone. The previous discussion leads to a formal definition for daters.

**Definition 47** (Dater). *A dater, denoted  $d$ , is an isotone mapping from  $\mathbb{Z}$  to  $\overline{\mathbb{R}}_{\max}$  such that  $d(k) = \varepsilon$  for  $k < 0$ . The set of daters is denoted  $\mathcal{D}$ .*

According to Rem. 3,  $\mathcal{D}$  is endowed with an operation  $\oplus$  and an order  $\leq$  induced respectively by the operation  $\oplus$  and the order  $\leq$  in the dioid  $\overline{\mathbb{R}}_{\max}$ .

**Remark 15.** *It is also possible to see daters as formal power series in  $\overline{\mathbb{R}}_{\max, \gamma} \llbracket \gamma \rrbracket$  (i.e., as isotone formal power series in  $\gamma$  with coefficients in  $\overline{\mathbb{R}}_{\max}$ ). This allows us to denote daters by formal power series.*

### 5.2.2. Expressing Synchronizations with Daters

In the following, standard and partial synchronizations are expressed in terms of daters. This leads to an algebraic representation for  $(\max, +)$ -systems with partial synchronization.

#### Expressing Standard Synchronizations with Daters

The standard synchronization “for all  $k \geq l$ , occurrence  $k$  of event  $e_2$  is at least  $\tau$  units of time after occurrence  $k - l$  of event  $e_1$ ” corresponds to the following inequality in  $\overline{\mathbb{R}}_{\max}$ :

$$\forall k \in \mathbb{Z}, \quad e_2(k) \geq \tau e_1(k - l)$$

Furthermore, the effect of several standard synchronizations on a single event is also expressed by a single inequality in  $\overline{\mathbb{R}}_{\max}$ . For example, the standard synchronizations “for all  $k \geq l_1$ , occurrence  $k$  of event  $e_2$  is at least  $\tau_1$  units of time after occurrence  $k - l_1$  of event  $e_{1,1}$ ” and “for all  $k \geq l_2$ , occurrence  $k$  of event  $e_2$  is at least  $\tau_2$  units of time after occurrence  $k - l_2$  of event  $e_{1,2}$ ” are both expressed by a single inequality in  $\overline{\mathbb{R}}_{\max}$ :

$$\forall k \in \mathbb{Z}, \quad e_2(k) \geq \tau_1 e_{1,1}(k - l_1) \oplus \tau_2 e_{1,2}(k - l_2)$$

Therefore, matrix inequalities in  $\overline{\mathbb{R}}_{\max}$  are suitable to express standard synchronizations. The standard synchronizations between events in the main system are summarized by

$$\begin{cases} x_1(k) \geq \bigoplus_{i=0}^{L_1} (A_{1,i} x_1(k - i) \oplus B_{1,i} u_1(k - i)) \\ y_1(k) \geq \bigoplus_{i=0}^{L_1} C_{1,i} x_1(k - i) \end{cases} \quad (5.1)$$

where  $x_1$ ,  $u_1$ , and  $y_1$  respectively correspond to the vectors of daters associated with state, input, and output events in the main system and  $L_1$  denotes the greatest parameter  $l$  over all standard synchronizations in the main system. Furthermore, matrices  $A_{1,i}$ ,  $B_{1,i}$ , and  $C_{1,i}$  belong respectively to  $\overline{\mathbb{R}}_{\max}^{n_1 \times n_1}$ ,  $\overline{\mathbb{R}}_{\max}^{n_1 \times m_1}$ , and  $\overline{\mathbb{R}}_{\max}^{p_1 \times n_1}$ . The entries of these matrices are given by the parameters of the standard synchronizations in the main system. In the same

way, the standard synchronizations between events in the secondary system are summarized by

$$\begin{cases} x_2(k) \geq \bigoplus_{i=0}^{L_2} (A_{2,i}x_2(k-i) \oplus B_{2,i}u_2(k-i)) \\ y_2(k) \geq \bigoplus_{i=0}^{L_2} C_{2,i}x_2(k-i) \end{cases} \quad (5.2)$$

where  $x_2$ ,  $u_2$ , and  $y_2$  respectively correspond to the vectors of daters associated with state, input, and output events in the secondary system and  $L_2$  denotes the greatest parameter  $l$  over all standard synchronizations in the secondary system. Furthermore, matrices  $A_{2,i}$ ,  $B_{2,i}$ , and  $C_{2,i}$  respectively belong to  $\overline{\mathbb{R}}_{\max}^{n_2 \times n_2}$ ,  $\overline{\mathbb{R}}_{\max}^{n_2 \times m_2}$ , and  $\overline{\mathbb{R}}_{\max}^{p_2 \times n_2}$ . The entries of these matrices are given by the parameters of standard synchronizations in the secondary system.

To simplify (5.1) and (5.2), the event set of the considered  $(\max, +)$ -system with partial synchronization is extended by additional state events. This allows us to convert (5.1) and (5.2) to first-order recursions. The theoretical validity of this step is ensured by Lem. 43.

**Lemma 43.** *Let  $l \in \mathbb{N}$ . In a  $(\max, +)$ -system with partial synchronization, the following (sets of) synchronizations are equivalent:*

1. “for all  $k \geq l$ , occurrence  $k$  of event  $e_2$  is at least  $\tau$  units of time after occurrence  $k - l$  of event  $e_1$ ”
2. “for all  $k \geq l - 1$ , occurrence  $k$  of event  $e_2$  is at least  $\tau$  units of time after occurrence  $k + 1 - l$  of event  $e_1$ ” and “for all  $k \geq 1$ , occurrence  $k$  of event  $e_i$  is at least zero units of time after occurrence  $k - 1$  of event  $e_1$ ” where state event  $e_i$  only appears in the two previous standard synchronizations
3. “for all  $k \geq 1$ , occurrence  $k$  of event  $e_2$  is at least zero units of time after occurrence  $k - 1$  of event  $e_i$ ” and “for all  $k \geq l - 1$ , occurrence  $k$  of event  $e_i$  occurs at least  $\tau$  units of time after occurrence  $k - l + 1$  of event  $e_1$ ” where state event  $e_i$  only appears in the two previous standard synchronizations

*Proof.* Only  $1 \Leftrightarrow 2$  is checked, as  $1 \Leftrightarrow 3$  can be obtained in the same way.

$1 \Rightarrow 2$ : Let us consider an event  $e_i$  only subject to the following standard synchronization: for all  $k \geq 1$ , occurrence  $k$  of event  $e_i$  is at least zero units of time after occurrence  $k - 1$  of event  $e_1$ . Then,

$$\forall k \in \mathbb{Z}, \quad e_i(k) \geq e_1(k - 1)$$

It remains to prove that the system includes the standard synchronization: “for all  $k \geq l - 1$ , occurrence  $k$  of event  $e_2$  is at least  $\tau$  units of time after occurrence  $k + 1 - l$  of event  $e_1$ ”. Event  $e_i$  is only subject to this standard synchronization. Hence, according to the earliest functioning rule,

$$\forall k \in \mathbb{Z}, \quad e_i(k) = e_1(k - 1)$$

Therefore,

$$\forall k \in \mathbb{Z}, \quad e_2(k) \geq \tau e_1(k - 1) = \tau e_i(k - 1 + 1)$$

Then, in terms of standard synchronizations, “for all  $k \geq 1$ , occurrence  $k$  of event  $e_2$  is at least  $\tau$  units of time after occurrence  $k + 1 - 1$  of event  $e_i$ ”.

$2 \Rightarrow 1$ : Conversely, the two standard synchronizations “for all  $k \geq 1$ , occurrence  $k$  of event  $e_2$  is at least  $\tau$  units of time after occurrence  $k + 1 - 1$  of event  $e_i$ ” and “for all  $k \geq 1$ , occurrence  $k$  of event  $e_i$  is at least zero units of time after occurrence  $k - 1$  of event  $e_1$ ” correspond, in terms of daters, to

$$\forall k \in \mathbb{Z}, \quad e_2(k) \geq \tau e_i(k - 1 + 1) \text{ and } e_i(k) \geq e_1(k - 1)$$

This implies, as the product is isotone in a dioid,

$$\forall k \in \mathbb{Z}, \quad e_2(k) \geq \tau e_1(k - 1)$$

The previous inequality corresponds to the standard synchronization “for all  $k \geq 1$ , occurrence  $k$  of event  $e_2$  is at least  $\tau$  units of time after occurrence  $k - 1$  of event  $e_1$ ”.  $\square$

According to Lem. 43, the different synchronization relations between events  $e_1$  and  $e_2$  pictured in Fig. 5.6 are equivalent.

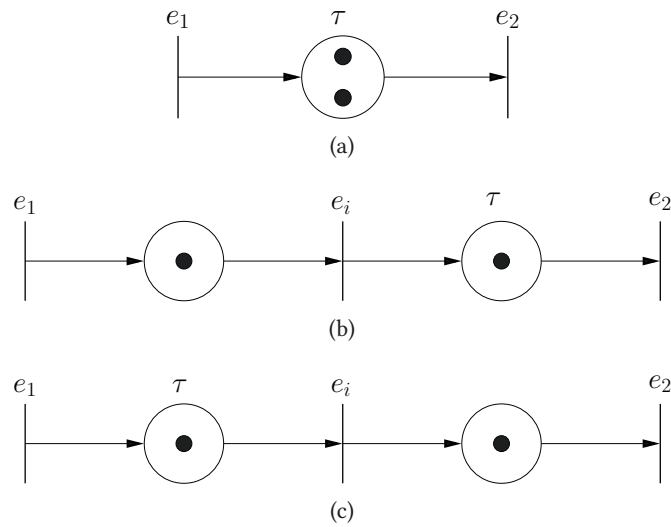

Figure 5.6.: Equivalent synchronizations if no other synchronizations affect event  $e_i$

By using repetitively Lem. 43, it is possible to set all entries of  $A_{1,i}$  and  $A_{2,i}$  for  $i \geq 2$  and of  $B_{1,i}$ ,  $C_{1,i}$ ,  $B_{2,i}$ , and  $C_{2,i}$  for  $i \geq 1$  to  $\varepsilon$  with additional state events. This leads to



the simplified representations for standard synchronizations in the main system and in the secondary system respectively given in (5.3) and (5.4).

$$\begin{cases} x_1(k) \geq A_{1,0}x_1(k) \oplus A_{1,1}x_1(k-1) \oplus B_{1,0}u_1(k) \\ y_1(k) \geq C_{1,0}x_1(k) \end{cases} \quad (5.3)$$

$$\begin{cases} x_2(k) \geq A_{2,0}x_2(k) \oplus A_{2,1}x_2(k-1) \oplus B_{2,0}u_2(k) \\ y_2(k) \geq C_{2,0}x_2(k) \end{cases} \quad (5.4)$$

In the following, only these representations are considered.

**Example 26.** For the  $(\max, +)$ -system with partial synchronization introduced in Ex. 23, the following matrix inequalities are obtained:

$$\begin{cases} x_1(k) \geq \begin{pmatrix} \varepsilon & \varepsilon & \varepsilon & \varepsilon \\ 10 & \varepsilon & \varepsilon & \varepsilon \\ \varepsilon & \varepsilon & \varepsilon & \varepsilon \\ \varepsilon & \varepsilon & 10 & \varepsilon \end{pmatrix} x_1(k) \oplus \begin{pmatrix} \varepsilon & e & \varepsilon & 2 \\ \varepsilon & \varepsilon & \varepsilon & \varepsilon \\ \varepsilon & 2 & \varepsilon & e \\ \varepsilon & \varepsilon & \varepsilon & \varepsilon \end{pmatrix} x_1(k-1) \oplus \begin{pmatrix} e & \varepsilon \\ \varepsilon & \varepsilon \\ \varepsilon & e \\ \varepsilon & \varepsilon \end{pmatrix} u_1(k) \\ y_1(k) \geq \begin{pmatrix} \varepsilon & e & \varepsilon & \varepsilon \\ \varepsilon & \varepsilon & \varepsilon & e \end{pmatrix} x_1(k) \end{cases}$$

$$\begin{cases} x_2(k) \geq A_{2,0}x_2(k) \oplus A_{2,1}x_2(k-1) \oplus B_{2,0}u_2(k) \\ y_2(k) \geq \begin{pmatrix} \varepsilon & \varepsilon & \varepsilon & e & \varepsilon & \varepsilon & \varepsilon & \varepsilon \\ \varepsilon & \varepsilon & \varepsilon & \varepsilon & \varepsilon & \varepsilon & \varepsilon & e \end{pmatrix} x_2(k) \end{cases}$$

with

$$A_{2,0} = \begin{pmatrix} \varepsilon & \varepsilon & \varepsilon & \varepsilon & \varepsilon & \varepsilon & \varepsilon & \varepsilon \\ 5 & \varepsilon & \varepsilon & \varepsilon & \varepsilon & \varepsilon & \varepsilon & \varepsilon \\ \varepsilon & 10 & \varepsilon & \varepsilon & \varepsilon & \varepsilon & \varepsilon & \varepsilon \\ \varepsilon & \varepsilon & 5 & \varepsilon & \varepsilon & \varepsilon & \varepsilon & \varepsilon \\ \varepsilon & \varepsilon & \varepsilon & 3 & \varepsilon & \varepsilon & \varepsilon & \varepsilon \\ \varepsilon & \varepsilon & \varepsilon & \varepsilon & 5 & \varepsilon & \varepsilon & \varepsilon \\ \varepsilon & \varepsilon & \varepsilon & \varepsilon & \varepsilon & 10 & \varepsilon & \varepsilon \\ \varepsilon & \varepsilon & \varepsilon & \varepsilon & \varepsilon & \varepsilon & 5 & \varepsilon \end{pmatrix} \quad B_{2,0} = \begin{pmatrix} e & \varepsilon \\ \varepsilon & \varepsilon \\ \varepsilon & \varepsilon \\ \varepsilon & \varepsilon \\ \varepsilon & e \\ \varepsilon & \varepsilon \\ \varepsilon & \varepsilon \\ \varepsilon & \varepsilon \end{pmatrix}$$

and

$$A_{2,1} = \begin{pmatrix} \varepsilon & \varepsilon & \varepsilon & \varepsilon & \varepsilon & \varepsilon & \varepsilon & \varepsilon & 3 \\ \varepsilon & \varepsilon & \varepsilon & \varepsilon & \varepsilon & \varepsilon & \varepsilon & \varepsilon & \varepsilon \\ \varepsilon & \varepsilon & \varepsilon & \varepsilon & \varepsilon & \varepsilon & \varepsilon & \varepsilon & \varepsilon \\ \varepsilon & \varepsilon & \varepsilon & \varepsilon & \varepsilon & \varepsilon & \varepsilon & \varepsilon & \varepsilon \\ \varepsilon & \varepsilon & \varepsilon & \varepsilon & \varepsilon & \varepsilon & \varepsilon & \varepsilon & \varepsilon \\ \varepsilon & \varepsilon & \varepsilon & \varepsilon & \varepsilon & \varepsilon & \varepsilon & \varepsilon & \varepsilon \\ \varepsilon & \varepsilon & \varepsilon & \varepsilon & \varepsilon & \varepsilon & \varepsilon & \varepsilon & \varepsilon \\ \varepsilon & \varepsilon & \varepsilon & \varepsilon & \varepsilon & \varepsilon & \varepsilon & \varepsilon & \varepsilon \end{pmatrix}$$

### Expressing Partial Synchronizations with Daters

The partial synchronization “event  $e_2$  can only occur when event  $e_1$  occurs” is expressed by the following condition on daters:

$$\forall k \in \mathbb{Z}, \quad e_2(k) \in \mathcal{A}(e_1) \text{ with } \mathcal{A}(e_1) = \{e_1(j) \mid j \in \mathbb{Z}\} \cup \{\top\}$$

The element  $\top$  is included in  $\mathcal{A}(e_1)$  to model the non-occurrence of event  $e_2$ . Thus,  $\varepsilon$  and  $\top$  always belong to  $\mathcal{A}(e_1)$ . The effect of several partial synchronizations on a single event is easily expressed by an intersection of sets. For example, the partial synchronizations “event  $e_2$  can only occur when event  $e_{1,1}$  occurs” and “event  $e_2$  can only occur when event  $e_{1,2}$  occurs” correspond to

$$\forall k \in \mathbb{Z}, \quad e_2(k) \in \mathcal{A}(e_{1,1}) \cap \mathcal{A}(e_{1,2})$$

To model partial synchronizations in a  $(\max, +)$ -system with partial synchronization, we first recall that, as mentioned in § 5.1.1, only partial synchronizations of state events in the secondary system by state events in the main system are considered. Then, a subset of  $\overline{\mathbb{R}}_{\max}$ , denoted  $\mathcal{A}_i$ , is associated with each state event  $x_{2,i}$  in the secondary system. Let us denote  $\mathcal{X}_i$  the set of state events in the main system synchronizing event  $x_{2,i}$ . Then,  $\mathcal{A}_i$  is defined by

$$\mathcal{A}_i = \begin{cases} \overline{\mathbb{R}}_{\max} & \text{if } \mathcal{X}_i = \emptyset \\ \bigcap_{x \in \mathcal{X}_i} \mathcal{A}(x) & \text{otherwise} \end{cases} \quad (5.5)$$

Hence, the partial synchronizations in a  $(\max, +)$ -system with partial synchronization are expressed by the following condition

$$\forall k \in \mathbb{Z}, \forall i, \quad x_{2,i}(k) \in \mathcal{A}_i$$

**Example 27.** For the example introduced in Ex. 23,

$$\begin{aligned} \mathcal{A}_1 &= \mathcal{A}_4 = \mathcal{A}_5 = \mathcal{A}_8 = \overline{\mathbb{R}}_{\max} \\ \mathcal{A}_2 &= \mathcal{A}(x_{1,1}) \text{ and } \mathcal{A}_3 = \mathcal{A}(x_{1,2}) \\ \mathcal{A}_6 &= \mathcal{A}(x_{1,3}) \text{ and } \mathcal{A}_7 = \mathcal{A}(x_{1,4}) \end{aligned}$$

### Algebraic Representation of a $(\max, +)$ -system with Partial Synchronization by Daters

The main system is modeled by

$$\begin{cases} x_1(k) \geq A_{1,0}x_1(k) \oplus A_{1,1}x_1(k-1) \oplus B_{1,0}u_1(k) \\ y_1(k) \geq C_{1,0}x_1(k) \end{cases} \quad (5.6)$$

The secondary system is modeled by

$$\begin{cases} x_2(k) \geq A_{2,0}x_2(k) \oplus A_{2,1}x_2(k-1) \oplus B_{2,0}u_2(k) \\ y_2(k) \geq C_{2,0}x_2(k) \\ \forall i, \quad x_{2,i}(k) \in \mathcal{A}_i \end{cases} \quad (5.7)$$

In (5.7), the first two equations represent the standard synchronizations in the secondary system and the third equation represents the partial synchronization of state events in the secondary system by state events in the main system. Then, the main system affects the secondary system through the sets  $\mathcal{A}_i$  which depend on the timing pattern of the state events in the main system (see (5.5)).

#### 5.2.3. Input-Output Behavior

In the following, a method to compute the response of a  $(\max, +)$ -system with partial synchronization to a predefined input specified by daters is discussed. As the secondary system does not affect the main system, we first focus on the main system. Second, we investigate the secondary system under a predefined behavior of the main system.

#### Main System

The synchronizations affecting the main system are summarized in (5.6). By convention,  $x_1(k)$  and  $y_1(k)$  have all entries equal to  $\varepsilon$  for  $k < 0$ . This choice is valid according to (5.6). As the behavior under the earliest functioning rule is considered, the time of occurrence  $k \geq 0$  of state events (*i.e.*,  $x_1(k)$ ) is given by the least solution of

$$\begin{cases} x \geq A_{1,0}x \oplus A_{1,1}x(k-1) \oplus B_{1,0}u_1(k) \\ x \geq x_1(k-1) \end{cases}$$

These two inequalities can be lumped into a single inequality.

$$x \geq A_{1,0}x \oplus (A_{1,1} \oplus \text{Id}) x_1(k-1) \oplus B_{1,0}u_1(k)$$

Therefore, according to Th. 5,

$$x_1(k) = A_{1,0}^* (A_{1,1} \oplus \text{Id}) x_1(k-1) \oplus A_{1,0}^* B_{1,0} u_1(k)$$

Furthermore, as the behavior under the earliest functioning rule is considered, the time of occurrence  $k \geq 0$  of output events (*i.e.*,  $y_1(k)$ ) is given by the least solution of

$$\begin{cases} x \geq C_{1,0}x_1(k) \\ x \geq y_1(k-1) \end{cases}$$

This leads directly to  $y_1(k) = C_{1,0}x_1(k) \oplus y_1(k-1)$ . This expression can be simplified by noticing that, for  $l$  in  $\mathbb{N}_0$ ,

$$\begin{aligned} C_{1,0}x_1(k) \oplus y_1(k-l) &= C_{1,0}x_1(k) \oplus C_{1,0}x_1(k-l) \oplus y_1(k-l-1) \\ &= C_{1,0}(x_1(k) \oplus x_1(k-l)) \oplus y_1(k-l-1) \\ &= C_{1,0}x_1(k) \oplus y_1(k-l-1) \text{ as } x_1(k) \geq x_1(k-l) \end{aligned}$$

Then, as  $y_1(-1) = \varepsilon$ ,

$$y_1(k) = C_{1,0}x_1(k) \oplus y_1(k-1) = C_{1,0}x_1(k) \oplus y_1(-1) = C_{1,0}x_1(k)$$

As, according to (2.7),  $x_1(k) = A_{1,0}^* x_1(k)$ , the main system is described by

$$\begin{cases} x_1(k) = A_1 x_1(k-1) \oplus B_1 u_1(k) \\ y_1(k) = C_1 x_1(k) \end{cases} \quad (5.8)$$

where  $A_1 = A_{1,0}^* (A_{1,1} \oplus \text{Id}) A_{1,0}^*$ ,  $B_1 = A_{1,0}^* B_{1,0}$ , and  $C_1 = C_{1,0} A_{1,0}^*$ . As mentioned in the introduction, the main system is a  $(\max, +)$ -linear system. This is not surprising, as the main system is only subject to standard synchronizations.

**Remark 16.** Equation (5.8) leads to an isotone input-output mapping from  $\mathcal{D}^{m_1}$  to  $\mathcal{D}^{p_1}$ , denoted  $\mathcal{H}_1$  and defined by  $\mathcal{H}_1(u_1) = y_1$ .

**Remark 17.** The structural controllability of the main system means that each row of  $A_1^* B_1$  contains at least one non-zero entry or, equivalently, each row of  $\left(\bigoplus_{j=0}^{n_1-1} A_1^j\right) B_1$  contains at least one non-zero entry.

The structural observability of the main system means that each column of  $C_1 A_1^*$  contains at least one non-zero entry or, equivalently, each column of  $C_1 \left(\bigoplus_{j=0}^{n_1-1} A_1^j\right)$  contains at least one non-zero entry.

### Secondary System

The synchronizations affecting the secondary system are summarized in (5.7). By convention,  $x_2(k)$  and  $y_2(k)$  have all entries equal to  $\varepsilon$  for  $k < 0$ . This choice is valid according to (5.7). As the behavior under the earliest functioning rule is considered, the time of occurrence  $k \geq 0$  of state events (*i.e.*,  $x_2(k)$ ) is given by the least solution of

$$\begin{cases} x \geq A_{2,0}x \oplus A_{2,1}x_2(k-1) \oplus B_{2,0}u_2(k) \\ \forall i, \quad x_i \in \mathcal{A}_i \\ x \geq x_2(k-1) \end{cases}$$

where the sets  $\mathcal{A}_i$  are obtained from the behavior of the main system. As in the main system, it is possible to lump the first and the third equations. This leads to

$$\begin{cases} x \geq A_{2,0}x \oplus (A_{2,1} \oplus \text{Id}) x_2(k-1) \oplus B_{2,0}u_2(k) \\ \forall i, \quad x_i \in \mathcal{A}_i \end{cases}$$

Due to partial synchronizations, it is not possible to directly use Th. 5 to calculate  $x_2(k)$ . However, using a reasoning very similar with [1, § 2.5.3], we can assume that  $A_{2,0}$  is strictly lower triangular by deleting state events, lumping state events, and adding input events. This allows us to get rid of the implicit terms by writing the first inequality componentwise. This leads to

$$\forall i, \quad \begin{cases} x_i \geq \bigoplus_{j=1}^{i-1} (A_{2,0})_{ij} x_j \oplus ((A_{2,1} \oplus \text{Id}) x_2(k-1) \oplus B_{2,0}u_2(k))_i \\ x_i \in \mathcal{A}_i \end{cases}$$

To compute  $x_2(k)$ , the mapping  $\Phi_i$  from  $\overline{\mathbb{R}}_{\max}$  to  $\overline{\mathbb{R}}_{\max}$  is introduced. Formally, mapping  $\Phi_i$  is defined by

$$\forall x \in \overline{\mathbb{R}}_{\max}, \quad \Phi_i(x) = \bigwedge \{z \in \mathcal{A}_i \mid z \geq x\}$$

As  $\top \in \mathcal{A}_i$ , mapping  $\Phi_i$  is well defined. Then,  $\Phi_i(x)$  is the least element in  $\mathcal{A}_i$  greater than or equal to  $x$ . Therefore,

$$\forall i, \quad x_{2,i}(k) = \Phi_i \left( \bigoplus_{j=1}^{i-1} (A_{2,0})_{ij} x_{2,j}(k) \oplus ((A_{2,1} \oplus \text{Id}) x_2(k-1) \oplus B_{2,0}u_2(k))_i \right)$$

In practice, the entries of  $x_2(k)$  have to be computed in a specific order (*i.e.*, for  $i$  from 1 to  $n_2$ ). For the output events, a reasoning similar to the one for the main system gives  $y_2(k) = C_2 x_2(k)$  with  $C_2 = C_{2,0}$ . Thus, the secondary system is described by

$$\begin{cases} x_2(k) = H(x_2(k-1), u_2(k)) \\ y_2(k) = C_2 x_2(k) \end{cases} \quad (5.9)$$

where the mapping  $H$  from  $\overline{\mathbb{R}}_{\max}^{n_2} \times \overline{\mathbb{R}}_{\max}^{m_2}$  to  $\overline{\mathbb{R}}_{\max}^{n_2}$  is defined by

$$H(x, u)_i = \Phi_i \left( \bigoplus_{j=1}^{i-1} (A_{2,0})_{ij} H(x, u)_j \oplus ((A_{2,1} \oplus \text{Id})x \oplus B_{2,0}u)_i \right) \quad (5.10)$$

**Remark 18.** Equation (5.9) leads to an isotone input-output mapping from  $\mathcal{D}^{m_2}$  to  $\mathcal{D}^{p_2}$ , denoted  $\mathcal{H}_{2,u_1}$  and defined by  $\mathcal{H}_{2,u_1}(u_2) = y_2$ . Due to partial synchronization, this mapping depends on the input of the main system  $u_1$ . Then, this leads to an input-output mapping  $\mathcal{H}$  for the complete  $(\max, +)$ -system with partial synchronization. Mapping  $\mathcal{H}$  is defined from  $\mathcal{D}^{m_1} \times \mathcal{D}^{m_2}$  to  $\mathcal{D}^{p_1} \times \mathcal{D}^{p_2}$  by

$$\mathcal{H}(u_1, u_2) = (y_1, y_2) = (\mathcal{H}_1(u_1), \mathcal{H}_{2,u_1}(u_2))$$

Mapping  $\mathcal{H}$  might be not isotone with respect to the canonical order as shown in Ex. 28.

**Example 28.** Consider the  $(\max, +)$ -system with partial synchronization drawn in Fig. 5.7. The input  $u^I$  is defined by

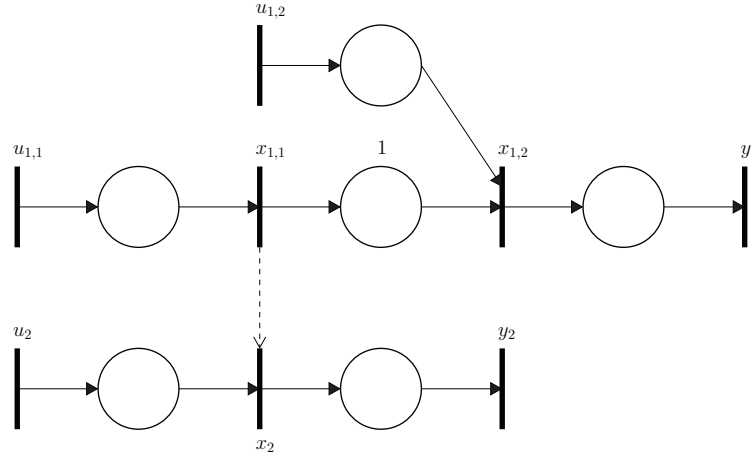

Figure 5.7.: A simple  $(\max, +)$ -system with partial synchronization

$$u_{1,1}^I(k) = \begin{cases} \varepsilon & \text{for } k < 0 \\ e & \text{for } k = 0 \\ \top & \text{for } k > 0 \end{cases} \quad u_{1,2}^I(k) = \begin{cases} \varepsilon & \text{for } k < 0 \\ 2 & \text{for } k = 0 \\ \top & \text{for } k > 0 \end{cases} \quad u_2^I(k) = \begin{cases} \varepsilon & \text{for } k < 0 \\ 1 & \text{for } k = 0 \\ \top & \text{for } k > 0 \end{cases}$$

The output induced by  $u^I$  is

$$y_1^I(k) = \begin{cases} \varepsilon & \text{for } k < 0 \\ 2 & \text{for } k = 0 \\ \top & \text{for } k > 0 \end{cases} \quad y_2^I(k) = \begin{cases} \varepsilon & \text{for } k < 0 \\ \top & \text{for } k \geq 0 \end{cases}$$

The input  $u^{\text{II}}$  is defined by

$$u_{1,1}^{\text{II}}(k) = \begin{cases} \varepsilon & \text{for } k < 0 \\ 1 & \text{for } k = 0 \\ \top & \text{for } k > 0 \end{cases} \quad u_{1,2}^{\text{II}} = u_{1,2}^{\text{I}} \quad u_2^{\text{II}} = u_2^{\text{I}}$$

The output induced by  $y^{\text{II}}$  is

$$y_1^{\text{II}} = y_1^{\text{I}} \quad y_2^{\text{II}}(k) = \begin{cases} \varepsilon & \text{for } k < 0 \\ 1 & \text{for } k = 0 \\ \top & \text{for } k > 0 \end{cases}$$

Then,  $u^{\text{I}} \leq u^{\text{II}}$ , but  $y^{\text{I}} > y^{\text{II}}$ . Hence, the input-output mapping  $\mathcal{H}$  associated with this system is not isotone.

**Example 29.** For the example introduced in Ex. 23, the output induced by

$$u_{1,1}(k) = u_{1,2}(k) = u_{2,1}(k) = u_{2,2}(k) = \begin{cases} \varepsilon & \text{for } k < 0 \\ e & \text{for } 0 \leq k < 15 \\ \top & \text{for } k \geq 15 \end{cases}$$

is computed. The main system is described by

$$\begin{cases} x_1(k) = \begin{pmatrix} 10 & e & 12 & 2 \\ 20 & 10 & 22 & 12 \\ 12 & 2 & 10 & e \\ 22 & 12 & 20 & 10 \end{pmatrix} x_1(k-1) \oplus \begin{pmatrix} e & \varepsilon \\ 10 & \varepsilon \\ \varepsilon & e \\ \varepsilon & 10 \end{pmatrix} u_1(k) \\ y_1(k) = \begin{pmatrix} 10 & e & \varepsilon & \varepsilon \\ \varepsilon & \varepsilon & 10 & e \end{pmatrix} x_1(k) \end{cases}$$

This leads to

$$y_{1,1}(k) = y_{1,2}(k) = \begin{cases} \varepsilon & \text{for } k < 0 \\ 10 \otimes 12^k & \text{for } 0 \leq k < 15 \\ \top & \text{for } k \geq 15 \end{cases}$$

Furthermore, the sets  $\mathcal{A}_i$  necessary for the dynamics of the secondary system are

$$\mathcal{A}_1 = \mathcal{A}_4 = \mathcal{A}_5 = \mathcal{A}_8 = \overline{\mathbb{R}}_{\max}$$

$$\mathcal{A}_2 = \mathcal{A}_6 = \{\varepsilon, e, 12, 24, 36, 48, 60, 72, 84, 96, 108, 120, 132, 144, 156, 168, \top\}$$

$$\mathcal{A}_3 = \mathcal{A}_7 = \{\varepsilon, 10, 22, 34, 46, 58, 70, 82, 94, 106, 118, 130, 142, 154, 166, 178, \top\}$$

## 5. Modeling

---

The output of the secondary system is given by

$$y_{2,1}(k) = \begin{cases} \varepsilon & \text{for } k < 0 \\ 27 \otimes 48^k & \text{for } 0 \leq k < 4 \\ \top & \text{for } k \geq 4 \end{cases}$$
$$y_{2,2}(k) = \begin{cases} \varepsilon & \text{for } k < 0 \\ 51 \otimes 48^k & \text{for } 0 \leq k < 3 \\ \top & \text{for } k \geq 3 \end{cases}$$



In this chapter, optimal control for  $(\max, +)$ -systems with partial synchronization is addressed. An output reference representing a deadline for output events is given. The aim of this approach is to enforce the just-in-time behavior: input events occur as late as possible while inducing an output respecting, as much as possible, the output reference. In practice, this objective is very interesting: for a transportation network, departures are delayed as much as possible while ensuring the schedule. Other criteria are presented in [20], but are not investigated in this thesis. Next, this control strategy is only investigated when the priority is given to the main system over the secondary system: the optimal input is first computed for the main system and, second, for the secondary system under a predefined behavior of the main system. In many applications, this assumption makes sense as the main system is shared by many independent secondary systems. Then, it might not be wise to operate the main system only to satisfy a single secondary system. This configuration might correspond to Ex. 23, if the train line is shared by many supply chains.

In the following, optimal feedforward control and its closed-loop version, namely model predictive control, are successively presented. Our approach is based on an analogy with results obtained for  $(\max, +)$ -linear systems: optimal feedforward control and model predictive control for  $(\max, +)$ -linear systems have been respectively developed in [9, 31] and in [20, 34]. The following results have been partly published in [18, 19]. To illustrate these control approaches, the results are applied to Ex. 23.

## 6.1. Optimal Feedforward Control

In optimal feedforward control, the output reference is given over a finite horizon and the input ensuring the just-in-time behavior is computed offline. The output reference for the main (resp. secondary) system is specified by a predefined vector of dates  $z_1 \in \mathcal{D}^{p_1}$  (resp.  $z_2 \in \mathcal{D}^{p_2}$ ). Furthermore, the restriction to a finite horizon means that there exists  $K \in \mathbb{N}_0$  such that, for all  $k \geq K$ ,  $z_1(k) = \top$  and  $z_2(k) = \top$ . To respect the output reference, the occurrences of output events should occur before or at the dates specified by the output reference. Formally, this requirement corresponds to  $y_1 \leq z_1$  and  $y_2 \leq z_2$ . Hence, the finite horizon assumption means that the output reference is constraining for the first  $K$  occurrences of output events. The optimal inputs  $u_1^*$  for the main system and  $u_2^*$  for the secondary system are selected to enforce the just-in-time behavior (*i.e.*, input events occur as late as possible while inducing an output respecting the output reference). As the priority is given to the main system over the secondary system,  $u_1^*$  is computed by neglecting the secondary system and, then,  $u_2^*$  is computed under the behavior of the main system induced by  $u_1^*$ .

### Main System

The main system is described by

$$\begin{cases} x_1(k) = A_1 x_1(k-1) \oplus B_1 u_1(k) \\ y_1(k) = C_1 x_1(k) \end{cases}$$

The optimal input  $u_1^*$  is selected to enforce the just-in-time behavior (*i.e.*, input events occur as late as possible while inducing an output respecting the output reference). Therefore,  $u_1^*$  corresponds to the greatest vector of dates inducing an output less than or equal to the output reference  $z_1$ . Hence,  $u_1^*$  is given by the greatest solution in  $\mathcal{D}^{m_1}$  of

$$\begin{cases} x_1(k) = A_1 x_1(k-1) \oplus B_1 u_1(k) \\ z_1(k) \geq C_1 x_1(k) \end{cases} \quad (6.1)$$

As  $z_1(k) = \top$  for  $k \geq K$ ,  $u_1^*(k) = \top$  for  $k \geq K$ . Therefore, it remains to determine the value of  $u_1^*(k)$  for  $0 \leq k < K$ . In the following, we denote  $\zeta_1(k)$  the least upper bound of  $x_1(k)$  in (6.1). Obviously,  $\zeta_1(k) = \top$  for  $k \geq K$ , as  $z_1(k) = \top$  for  $k \geq K$ . Furthermore, as the only conditions on  $\zeta_1(k)$  expressed by (6.1) are  $z_1(k) \geq C_1 \zeta_1(k)$  and  $\zeta_1(k+1) \geq A_1 \zeta_1(k)$ ,  $\zeta_1(k)$  is given by the backward recursive equation

$$\zeta_1(k) = A_1 \downarrow \zeta_1(k+1) \wedge C_1 \downarrow z_1(k)$$

This relation allows us to calculate  $\zeta_1(k)$  for  $0 \leq k < K$ . Furthermore, the single condition on  $u_1(k)$  induced by (6.1) is  $\zeta_1(k) \geq B_1 u_1(k)$ . Therefore,  $u_1(k) \leq B_1 \downarrow \zeta_1(k)$ . As  $A_1 \geq \text{Id}$ ,

the condition  $\zeta_1(k+1) \geq A_1 \zeta_1(k)$  implies  $\zeta_1(k+1) \geq \zeta_1(k)$ . Then, as the left-division by  $B_1$  is isotone,

$$B_1 \setminus \zeta_1(k+1) \geq B_1 \setminus \zeta_1(k)$$

Therefore, taking  $u_1^*(k) = B_1 \setminus \zeta_1(k)$  is a valid choice. Hence, the optimal input  $u_1^*(k)$  for  $0 \leq k < K$  is given by

$$\begin{cases} \zeta_1(k) = C_1 \setminus z_1(k) \wedge A_1 \setminus \zeta_1(k+1) \\ u_1^*(k) = B_1 \setminus \zeta_1(k) \end{cases} \quad \text{with } \zeta_1(K) = \top \quad (6.2)$$

### Secondary System

The secondary system is described by

$$\begin{cases} x_2(k) = H(x_2(k-1), u_2(k)) \\ y_2(k) = C_2 x_2(k) \end{cases}$$

The mapping  $H$  from  $\overline{\mathbb{R}}_{\max}^{n_2} \times \overline{\mathbb{R}}_{\max}^{m_2}$  to  $\overline{\mathbb{R}}_{\max}^{n_2}$  is defined by

$$H(x, u)_i = \Phi_i \left( \bigoplus_{j=1}^{i-1} (A_{2,0})_{ij} H(x, u)_j \oplus ((A_{2,1} \oplus \text{Id})x \oplus B_{2,0}u)_i \right)$$

where  $\Phi_i(x) = \bigwedge \{z \in \mathcal{A}_i | z \geq x\}$  with set  $\mathcal{A}_i$  depending on the behavior of the main system.

The optimal input  $u_2^*$  is selected to enforce the just-in-time behavior (*i.e.*, input events occur as late as possible while inducing an output respecting the output reference). Therefore,  $u_2^*$  corresponds to the greatest vector of daters inducing an output less than or equal to the output reference  $z_2$ . Hence,  $u_2^*$  is given by the greatest solution in  $\mathcal{D}^{m_2}$  of

$$\begin{cases} x_2(k) = H(x_2(k-1), u_2(k)) \\ z_2(k) \geq C_2 x_2(k) \end{cases} \quad (6.3)$$

As  $z_2(k) = \top$  for  $k \geq K$ ,  $u_2^*(k) = \top$  for  $k \geq K$ . Therefore, it remains to determine the value of  $u_2^*(k)$  for  $0 \leq k < K$ . Before solving this problem, some properties of the mappings  $\Phi_i$  and  $H$  are formalized.

**Lemma 44.** *Let  $\mathcal{A}$  be a finite subset of  $\overline{\mathbb{R}}_{\max}$  such that  $\{\varepsilon, \top\} \subseteq \mathcal{A}$ . The mapping  $\Phi$  defined by*

$$\forall x \in \overline{\mathbb{R}}_{\max}, \quad \Phi(x) = \bigwedge \{z \in \mathcal{A} | z \geq x\}$$

*is residuated and its residual is given by*

$$\forall x \in \overline{\mathbb{R}}_{\max}, \quad \Phi^\sharp(x) = \bigoplus \{z \in \mathcal{A} | z \leq x\}$$

## 6. Optimal Control

---

*Proof.* This proof is based on Th. 1. Let us denote  $\Psi$  the mapping from  $\overline{\mathbb{R}}_{\max}$  to  $\overline{\mathbb{R}}_{\max}$  defined by

$$\forall x \in \overline{\mathbb{R}}_{\max}, \quad \Psi(x) = \bigoplus \{z \in \mathcal{A} \mid z \leq x\}$$

Mappings  $\Phi$  and  $\Psi$  are well defined, as  $\varepsilon$  and  $\top$  belong to  $\mathcal{A}$ . Furthermore, mappings  $\Phi$  and  $\Psi$  are isotone. Finally,  $\Phi(x)$  and  $\Psi(x)$  always belong to  $\mathcal{A}$ , as  $\mathcal{A}$  is finite. Then,

$$\begin{aligned} \forall x \in \overline{\mathbb{R}}_{\max}, \quad (\Psi \circ \Phi)(x) &= \Phi(x) \geq x \\ (\Phi \circ \Psi)(x) &= \Psi(x) \leq x \end{aligned}$$

This leads to  $\Psi \circ \Phi \geq \text{Id}$  and  $\Phi \circ \Psi \leq \text{Id}$ . Hence, according to Th. 1,  $\Phi$  is residuated and its residual is  $\Psi$ .  $\square$

**Remark 19.** Lem. 44 does not hold anymore when  $\mathcal{A}$  is not finite. Consider the set  $\mathcal{A}$  defined by

$$\mathcal{A} = \left\{ 2 - \frac{1}{n} \mid n \in \mathbb{N} \right\}$$

Then,  $\Phi(\bigoplus_{x \in \mathcal{A}} x) = \Phi(2) = \top$ , but  $\bigoplus_{x \in \mathcal{A}} \Phi(x) = 2$ . Then, according to Th. 3,  $\Phi$  is not residuated.

**Lemma 45.** Let  $H$  be the mapping defined in (5.10) and  $z \in \overline{\mathbb{R}}_{\max}^{n_2}$ . If all mappings  $\Phi_i$  are residuated, the inequality  $H(x, u) \leq z$  admits a greatest solution denoted  $(F(z), G(z))$  defined by

$$F(z) = (A_{2,1} \oplus \text{Id}) \wp \mathbb{R} \text{ and } G(z) = B_{2,0} \wp \mathbb{R}$$

where  $R_i = \Phi_i^\sharp(r_i)$  and  $r_i = z_i \wedge \bigwedge_{j=i+1}^{n_2} (A_{2,0})_{ji} \wp R_j$ .

*Proof.* First, we prove that  $H(x, u) \leq z \Leftrightarrow H(x, u) \leq r$ . As, by definition,  $r \leq z$ ,  $H(x, u) \leq r$  implies  $H(x, u) \leq z$ . Conversely, we reason by induction over index  $i$  decreasing from  $n_2$  to 1. For  $i = n_2$ , as  $r_{n_2} = z_{n_2}$ ,  $H(x, u)_{n_2} \leq z_{n_2}$  implies  $H(x, u)_{n_2} \leq r_{n_2}$ . For  $1 \leq i < n_2$ , we assume that  $H(x, u)_j \leq r_j$  for  $i < j \leq n_2$ . Then,

$$\begin{aligned} \forall j \text{ with } i < j \leq n_2, \quad H(x, u)_j &\leq r_j \\ \Rightarrow \forall j \text{ with } i < j \leq n_2, \quad \bigoplus_{k=1}^{j-1} (A_{2,0})_{jk} H(x, u)_k &\leq R_j \\ \Rightarrow \forall j \text{ with } i < j \leq n_2, \quad H(x, u)_i &\leq (A_{2,0})_{ji} \wp R_j \\ \Rightarrow H(x, u)_i &\leq \bigwedge_{j=i+1}^{n_2} (A_{2,0})_{ji} \wp R_j \end{aligned}$$

As  $H(x, u) \leq z$ ,

$$H(x, u)_i \leq z_i \wedge \bigwedge_{j=i+1}^{n_2} (A_{2,0})_{ji} \setminus R_j = r_i$$

This completes the induction. Therefore,

$$\begin{aligned} H(x, u) &\leq z \\ \Leftrightarrow H(x, u) &\leq r \\ \Leftrightarrow \forall i, \bigoplus_{j=1}^{i-1} (A_{2,0})_{ij} H(x, u)_j \oplus ((A_{2,1} \oplus \text{Id})x \oplus B_{2,0}u)_i &\leq R_i \end{aligned}$$

Furthermore, as  $H(x, u) \leq r$ ,

$$\begin{aligned} \bigoplus_{j=1}^{i-1} (A_{2,0})_{ij} H(x, u)_j &\leq \bigoplus_{j=1}^{i-1} (A_{2,0})_{ij} r_j \\ &\leq \bigoplus_{j=1}^{i-1} (A_{2,0})_{ij} \left( (A_{2,0})_{ij} \setminus R_i \right) \\ &\leq R_i \end{aligned}$$

Hence,

$$\begin{aligned} H(x, u) &\leq z \\ \Leftrightarrow \forall i, ((A_{2,1} \oplus \text{Id})x \oplus B_{2,0}u)_i &\leq R_i \\ \Leftrightarrow (A_{2,1} \oplus \text{Id})x \oplus B_{2,0}u &\leq R \\ \Leftrightarrow x \leq (A_{2,1} \oplus \text{Id}) \setminus R \text{ and } u &\leq B_{2,0} \setminus R \end{aligned}$$

Therefore, the inequality  $H(x, u) \leq z$  admits a greatest solution  $(F(z), G(z))$  given by

$$F(z) = (A_{2,1} \oplus \text{Id}) \setminus R \text{ and } G(z) = B_{2,0} \setminus R$$

□

In the following, we denote  $\zeta_2(k)$  the least upper bound of  $x_2(k)$  in (6.3). Obviously,  $\zeta_2(k) = \top$  for  $k \geq K$ , as  $z_2(k) = \top$  for  $k \geq K$ . Furthermore, the only conditions on  $\zeta_2(k)$  expressed by (6.3) are  $z_2(k) \geq C_2 \zeta_2(k)$  and  $\zeta_2(k+1) \geq H(\zeta_2(k), u_2(k+1))$ . Besides,

as the main system is structurally controllable,

$$\begin{aligned}
 \forall k \geq K + n_1, \quad x_1^*(k) &\geq \bigoplus_{j=0}^{n_1-1} A_1^j B_1 u_1^*(k-j) \\
 &\geq \bigoplus_{j=0}^{n_1-1} A_1^j B_1 \top \\
 &\geq \left( \bigoplus_{j=0}^{n_1-1} A_1^j B_1 \right) \top \\
 &\geq \top \text{ according to Rem. 16}
 \end{aligned}$$

Therefore,  $x_1^*(k) = \top$  for  $k \geq K + n_1$ . Hence, for all state event  $x_{2,i}$ , either the sets  $\mathcal{A}_i$  associated with  $\Phi_i$  is finite or  $\Phi_i = \text{Id}$ . In both cases, according to Lem. 44, mapping  $\Phi_i$  is residuated. Hence, according to Lem. 45,  $\zeta_2(k)$  is given by the backward recursive equation

$$\zeta_2(k) = F(\zeta_2(k+1)) \wedge C_2 \downarrow z_2(k)$$

This relation allows us to calculate  $\zeta_2(k)$  for  $0 \leq k < K$ . Furthermore, the single condition on  $u_2(k)$  induced by (6.3) is  $\zeta_2(k) \geq H(\zeta_2(k-1), u_2(k))$ . Therefore,  $u_2(k) \leq G(\zeta_2(k))$ . As the mapping  $F$  is isotone,  $\zeta_2(k+1) \geq \zeta_2(k)$ . Then, as the mapping  $G$  is isotone,

$$G(\zeta_2(k+1)) \geq G(\zeta_2(k))$$

Therefore, taking  $u_2^*(k) = G(\zeta_2(k))$  is a valid choice. Hence, the optimal input  $u_2^*(k)$  for  $0 \leq k < K$  is given by

$$\begin{cases} \zeta_2(k) = C_2 \downarrow z_2(k) \wedge F(\zeta_2(k+1)) \\ u_2^*(k) = G(\zeta_2(k)) \end{cases} \quad \text{with } \zeta_2(K) = \top \quad (6.4)$$

**Remark 20.** *The previous control strategy consists in finding the greatest, according to a specific order denoted  $\leq_{\mathcal{L}}$ , solution of*

$$\mathcal{H}(u_1, u_2) \leq (z_1, z_2)$$

where  $z_1$  (resp.  $z_2$ ) denotes the vector of dates associated with the output reference for the main (resp. secondary) system. The order  $\leq_{\mathcal{L}}$  corresponds to a lexicographic order based on the partition in main system and secondary system, i.e.,

$$(u_1^I, u_2^I) \leq_{\mathcal{L}} (u_1^{II}, u_2^{II}) \Leftrightarrow \begin{cases} u_1^I < u_1^{II} \\ \text{or} \\ u_1^I = u_1^{II} \text{ and } u_2^I \leq u_2^{II} \end{cases}$$

The inequality  $\mathcal{H}(u_1, u_2) \leq (z_1, z_2)$  admits a greatest, according to  $\leq_{\mathcal{L}}$ , solution. But, in Ex. 28,  $u^I \leq_{\mathcal{L}} u^{II}$ , but  $y^I > y^{II}$ . Then, mapping  $\mathcal{H}$  is not isotone.

Furthermore, the inequality  $\mathcal{H}(u_1, u_2) \leq (z_1, z_2)$  might not admit a greatest, according to  $\leq$ , solution, as shown in Ex. 30. Hence, the specific order  $\leq_{\mathcal{L}}$  has not only a practical meaning, but ensures also the existence of a unique optimal input.

**Example 30.** Let us consider the  $(\max, +)$ -system with partial synchronization drawn in Fig. 6.1. The following output reference is considered.

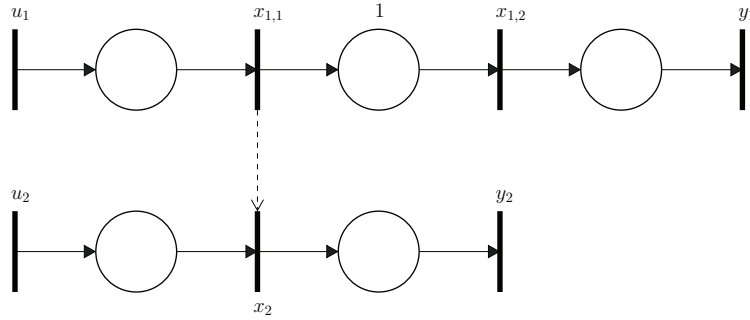

Figure 6.1.: A simple  $(\max, +)$ -system with partial synchronization

$$z_1(k) = \begin{cases} \varepsilon & \text{for } k < 0 \\ 2 & \text{for } k = 0 \\ \top & \text{for } k > 0 \end{cases} \quad z_2(k) = \begin{cases} \varepsilon & \text{for } k < 0 \\ e & \text{for } k = 0 \\ \top & \text{for } k > 0 \end{cases}$$

The incomparable inputs  $u^I$  and  $u^{II}$  defined by

$$u_1^I(k) = \begin{cases} \varepsilon & \text{for } k < 0 \\ 1 & \text{for } k = 0 \\ \top & \text{for } k > 0 \end{cases} \quad u_2^I(k) = \begin{cases} \varepsilon & \text{for } k < 1 \\ \top & \text{for } k \geq 1 \end{cases}$$

$$u_1^{II}(k) = u_2^{II}(k) = \begin{cases} \varepsilon & \text{for } k < 0 \\ e & \text{for } k = 0 \\ \top & \text{for } k > 0 \end{cases}$$

induce outputs less than or equal to  $z$ . However, the input  $u^I \oplus u^{II}$  does not lead to an output less than or equal to the reference output. Hence, the inequality  $\mathcal{H}(u_1, u_2) \leq (z_1, z_2)$  does not admit a greatest solution with respect to  $\leq$ .

**Example 31.** In the following, optimal feedforward control is applied to Ex. 23. The output reference  $z_1$  for the main system is defined as

$$z_{1,1}(k) = z_{1,2}(k) = \begin{cases} \varepsilon & \text{for } k < 0 \\ 10 \otimes 20^k & \text{for } 0 \leq k < 20 \\ \top & \text{for } k \geq 20 \end{cases}$$

This leads to the following optimal input  $u_1^*$  for the main system.

$$u_{1,1}^*(k) = u_{1,2}^*(k) = \begin{cases} \varepsilon & \text{for } k < 0 \\ 20^k & \text{for } 0 \leq k < 20 \\ \top & \text{for } k \geq 20 \end{cases}$$

The output induced by  $u_1^*$ , denoted  $y_1^*$ , is equal to  $z_1$ . Hence,  $y_1^* \leq z_1$ . Under this specific behavior of the main system, the optimal input for the secondary system is computed. The considered output reference, denoted  $z_2$ , is defined as

$$z_{2,1}(k) = \begin{cases} \varepsilon & \text{for } k < 0 \\ 20 \otimes 80^k & \text{for } 0 \leq k < 5 \\ \top & \text{for } k \geq 5 \end{cases} \quad \text{and } z_{2,2}(k) = \begin{cases} \varepsilon & \text{for } k < 0 \\ 55 \otimes 80^k & \text{for } 0 \leq k < 5 \\ \top & \text{for } k \geq 5 \end{cases}$$

This leads to the following optimal input  $u_2^*$  for the secondary system.

$$u_{2,1}^*(k) = \begin{cases} \varepsilon & \text{for } k < 1 \\ 75 \otimes 80^{k-1} & \text{for } 1 \leq k < 5 \\ \top & \text{for } k \geq 5 \end{cases} \quad \text{and } u_{2,2}^*(k) = \begin{cases} \varepsilon & \text{for } k < 0 \\ 35 \otimes 80^k & \text{for } 0 \leq k < 5 \\ \top & \text{for } k \geq 5 \end{cases}$$

The output induced by  $u_2^*$ , denoted  $y_2^*$ , is

$$y_{2,1}^*(k) = \begin{cases} \varepsilon & \text{for } k < 1 \\ 95 \otimes 80^{k-1} & \text{for } 1 \leq k < 5 \\ \top & \text{for } k \geq 5 \end{cases} \quad \text{and } y_{2,2}^*(k) = \begin{cases} \varepsilon & \text{for } k < 0 \\ 55 \otimes 80^k & \text{for } 0 \leq k < 5 \\ \top & \text{for } k \geq 5 \end{cases}$$

Clearly,  $y_2^* \leq z_2$ .

### 6.1.1. Feasibility

In the previous reasoning, the practical implementation of the optimal input has not been considered. This aspect may cause a problem: in Ex. 31, the optimal input leads to a first occurrence of input event  $u_{2,1}$  at  $t = -\infty$ , but this requirement cannot be met in practice, as the system starts at  $t = 0$ . To tackle this problem, the notion of realizability for daters is introduced.



**Definition 48** (Realizable dater). *A dater  $d$  is said to be realizable if, for all  $k \in \mathbb{N}_0$ ,  $d(k) \geq e$ . The least realizable dater, denoted  $\underline{r}$ , is defined by*

$$\underline{r}(k) = \begin{cases} \varepsilon & \text{for } k < 0 \\ e & \text{for } k \geq 0 \end{cases}$$

*A vector of daters is said to be realizable if all its entries are realizable.*

Intuitively, a realizable dater is a dater which can be implemented in practice as the timing pattern of an input event. In the following, we require the optimal input to be realizable. This comes at a price: the output reference cannot be respected in general. In Ex. 31, requiring the optimal input to be realizable leads to  $u_{2,1}^*(0) \geq e$ . Then, the realizable optimal input cannot be less than or equal to the optimal input computed in Ex. 31. Hence, the output of the secondary system cannot be less than or equal to the output reference  $z_2$ . This illustrates the need for relaxing the output reference to obtain a realizable optimal input. To formalize this condition, the notion of feasibility for an output reference is introduced.

**Definition 49** (Feasibility). *In a  $(\max, +)$ -system with partial synchronization, an output reference is said to be feasible if the associated optimal input is realizable.*

Hence, the problem is to find a feasible output reference  $\tilde{z}$ , partitioned in output reference  $\tilde{z}_1$  for the main system and output reference  $\tilde{z}_2$  for the secondary system, greater than or equal to the original output reference  $z$ . Furthermore, as the behavior of the system should respect as much as possible the original output reference, we require  $\tilde{z}$  to be the least feasible output reference greater than or equal to  $z$ . In the following, the problem of finding this output reference is first addressed for the main system and, then, for the secondary system under a predefined behavior of the main system.

### Main System

Let  $w_1$  be an output reference for the main system. The feasibility of  $w_1$  is equivalent to an optimal input associated with  $w_1$  greater than or equal to  $\underline{u}_1$  where  $\underline{u}_1$  is the vector in  $\mathcal{D}^{m_1}$  with entries equal to  $\underline{r}$ . As  $\mathcal{H}_1$  is isotone, this implies  $w_1 \geq \mathcal{H}_1(\underline{u}_1)$ . Conversely,  $w_1 \geq \mathcal{H}_1(\underline{u}_1)$  implies that the optimal input associated with  $w_1$  is greater than or equal to  $\underline{u}_1$ . Therefore,

$$w_1 \text{ is feasible} \Leftrightarrow w_1 \geq \mathcal{H}_1(\underline{u}_1)$$

Hence, the least feasible output reference  $\tilde{z}_1$  greater than or equal to  $z_1$  is given by

$$\tilde{z}_1 = \mathcal{H}_1(\underline{u}_1) \oplus z_1$$

With the method developed before, the calculation of  $\mathcal{H}_1(\underline{u}_1)$  requires an infinite amount of time. However, as the original output reference  $z_1$  is defined over a finite event horizon,  $\tilde{z}_1$  is also defined over the same finite event horizon and can be computed in a finite amount of time. The realizable optimal input  $\tilde{u}_1^*$  is obtained from the feasible output reference  $\tilde{z}_1$  using the method developed before.

### Secondary System

The previous approach can be directly transposed to the secondary system. Then,  $\tilde{u}_2^*$  is obtained from the relaxed output reference  $\tilde{z}_2 = z_2 \oplus \mathcal{H}_{2, \tilde{u}_1^*}(\underline{u}_2)$ , where  $\underline{u}_2$  is the vector in  $\mathcal{D}^{m_2}$  with entries equal to  $\underline{r}$ , by using the method developed before.

**Example 32.** *The previous method is applied in Ex. 31 to obtain a realizable optimal input. The problem is already solved for the main system, as  $u_1^*$  is realizable. However, for the secondary system,  $u_2^*$  is not realizable. Hence, the output reference  $z_2$  defined by*

$$z_{2,1}(k) = \begin{cases} \varepsilon & \text{for } k < 0 \\ 20 \otimes 80^k & \text{for } 0 \leq k < 5 \\ \top & \text{for } k \geq 5 \end{cases} \quad \text{and } z_{2,2}(k) = \begin{cases} \varepsilon & \text{for } k < 0 \\ 55 \otimes 80^k & \text{for } 0 \leq k < 5 \\ \top & \text{for } k \geq 5 \end{cases}$$

*is not feasible and has to be relaxed. The least feasible output reference greater than or equal to  $z_2$ , denoted  $\tilde{z}_2$ , is defined by*

$$\tilde{z}_{2,1}(k) = \begin{cases} \varepsilon & \text{for } k < 0 \\ 35 \otimes 80^k & \text{for } 0 \leq k < 5 \\ \top & \text{for } k \geq 5 \end{cases} \quad \text{and } z_{2,2}(k) = \begin{cases} \varepsilon & \text{for } k < 0 \\ 75 \otimes 80^k & \text{for } 0 \leq k < 5 \\ \top & \text{for } k \geq 5 \end{cases}$$

*This leads to a realizable optimal input  $\tilde{u}_2^*$  for the secondary system where*

$$\tilde{u}_{2,1}^*(k) = \begin{cases} \varepsilon & \text{for } k < 0 \\ 15 \otimes 80^k & \text{for } 0 \leq k < 5 \\ \top & \text{for } k \geq 5 \end{cases} \quad \text{and } \tilde{u}_{2,2}^*(k) = \begin{cases} \varepsilon & \text{for } k < 0 \\ 55 \otimes 80^k & \text{for } 0 \leq k < 5 \\ \top & \text{for } k \geq 5 \end{cases}$$

*The output induced by  $\tilde{u}_2^*$ , denoted  $\tilde{y}_2^*$ , is equal to  $\tilde{z}_2$ . Hence,  $\tilde{y}_2^* \leq \tilde{z}_2$ . However,  $\tilde{y}_2^*$  is not less than or equal to  $z_2$ .*

### 6.1.2. Characterization with Cost Functions

The aim of this section is to characterize with cost functions the optimality criterion developed in § 6.1.1. First, two particular cost functions are introduced. The first cost

function, denoted  $J_{1,1}$  for the main system and  $J_{1,2}$  for the secondary system, corresponds to the tardiness criterion and is defined by

$$J_{1,i}(y_i) = \sum_{j=1}^{p_i} \sum_{k=0}^{K-1} \max(y_{i,j}(k) - z_{i,j}(k), 0) \text{ with } i \in \{1, 2\}$$

In the tardiness criterion, a penalty is paid for delays with respect to the output reference  $z_i$ . The second cost function, denoted  $J_{2,1}$  for the main system and  $J_{2,2}$  for the secondary system, corresponds to the just-in-time criterion

$$J_{2,i}(y_i) = - \sum_{j=1}^{m_i} \sum_{k=0}^{K-1} u_{i,j}(k) \text{ with } i \in \{1, 2\}$$

In the just-in-time criterion, a penalty is paid when input events are brought forward.

In the following, an optimal control approach based on these cost functions is investigated. The problem is first solved for the main system and, second, for the secondary system under a predefined behavior of the main system. For each system, the tardiness criterion is first minimized. Then, among all inputs optimal with respect to the tardiness criterion, an input optimal with respect to the just-in-time criterion is selected. In practice, this approach makes sense: the objective is to respect the output reference (*i.e.*, the schedule) and, under this condition, it might also be interesting to ensure just-in-time behavior (*i.e.*, delay the departures).

To avoid a cumbersome discussion over infinite costs, we assume that the reference output  $z$  and  $\underline{y}$  (*i.e.*, the response to the least realizable input  $\underline{u}$ ) take value in  $\mathbb{R}_0^+$  over the finite event horizon of length  $K$ . In practice, this assumption is not restrictive.

### Main System

The first step consists in finding the optimal cost for the tardiness criterion. Formally, this corresponds to solving the following optimization problem:

$$\begin{aligned} & \text{minimize } J_{1,1}(y_1) \\ & \text{subject to} \\ & \begin{cases} x_1(k) = A_1 x_1(k-1) \oplus B_1 u_1(k) \\ y_1(k) = C_1 x_1(k) \\ u_1(k+1) \geq u_1(k) \end{cases} \quad \text{for } 0 \leq k < K \\ & x_1(-1) = \varepsilon, u_1(0) \geq e, u_1(K) = \top \end{aligned} \tag{6.5}$$

As  $y_1^I \geq y_1^{II}$  implies  $J_{1,1}(y_1^I) \geq J_{1,1}(y_1^{II})$ , it is sufficient to find the least output  $y_1$  in (6.5). Furthermore, as the input-output mapping  $\mathcal{H}_1$  associated with the main system is isotone,

it is sufficient to find the least input  $\underline{u}_1^K$  admissible with respect to (6.5). The entries of the input  $\underline{u}_1^K$  are all equal to  $e_K$  defined by

$$e_K(k) = \begin{cases} \varepsilon & \text{for } k < 0 \\ e & \text{for } 0 \leq k < K \\ \top & \text{for } k \geq K \end{cases}$$

Thus, the optimal cost in (6.5), denoted  $J_{1,1}^{\text{opt}}$ , is given by  $J_{1,1}(\underline{y}_1^K)$  where  $\underline{y}_1^K = \mathcal{H}_1(\underline{u}_1^K)$ . By assumption,  $J_{1,1}^{\text{opt}}$  is finite. The second step consists in solving

$$\begin{aligned} & \text{minimize } J_{1,2}(\mathbf{u}_1) \\ & \text{subject to} \\ & \begin{cases} x_1(k) = A_1 x_1(k-1) \oplus B_1 u_1(k) \\ y_1(k) = C_1 x_1(k) \\ u_1(k+1) \geq u_1(k) \end{cases} \quad \text{for } 0 \leq k < K \\ & J_{1,1}(\mathbf{y}_1) = J_{1,1}^{\text{opt}} \\ & x_1(-1) = \varepsilon, u_1(0) \geq e, u_1(K) = \top \end{aligned} \tag{6.6}$$

Since  $y_1 \geq \underline{y}_1$ , for  $0 \leq k < K$  and  $1 \leq j \leq p_1$ ,

$$\max(y_{1,j}(k) - z_{1,j}(k), 0) \geq \max(\underline{y}_{1,j}(k) - z_{1,j}(k), 0)$$

Hence, as  $J_{1,1}^{\text{opt}}$  is finite,  $J_{1,1}(\mathbf{u}_1) = J_{1,1}^{\text{opt}}$  is equivalent to, for  $0 \leq k < K$  and  $1 \leq j \leq p_1$ ,

$$\max(y_{1,j}(k) - z_{1,j}(k), 0) = \max(\underline{y}_{1,j}(k) - z_{1,j}(k), 0)$$

If  $z_{1,j}(k) \geq \underline{y}_{1,j}(k)$ ,

$$\begin{aligned} \max(y_{1,j}(k) - z_{1,j}(k), 0) &= \max(\underline{y}_{1,j}(k) - z_{1,j}(k), 0) \\ &\Leftrightarrow \max(y_{1,j}(k) - z_{1,j}(k), 0) = 0 \\ &\Leftrightarrow y_{1,j}(k) \leq z_{1,j}(k) \end{aligned}$$

Otherwise, if  $z_{1,j}(k) < \underline{y}_{1,j}(k)$ ,

$$\begin{aligned} \max(y_{1,j}(k) - z_{1,j}(k), 0) &= \max(\underline{y}_{1,j}(k) - z_{1,j}(k), 0) \\ &\Leftrightarrow \max(y_{1,j}(k) - z_{1,j}(k), 0) = \underline{y}_{1,j}(k) - z_{1,j}(k) \\ &\Leftrightarrow y_{1,j}(k) = \underline{y}_{1,j}(k) \\ &\Leftrightarrow y_{1,j}(k) \leq \underline{y}_{1,j}(k) \end{aligned}$$

Thus,  $J_{1,1}(\mathbf{u}_1) = J_{1,1}^{\text{opt}}$  is equivalent to  $\mathbf{y}_1 \leq \tilde{\mathbf{z}}_1$ , where  $\tilde{\mathbf{z}}_1$  is the least feasible output reference greater than or equal to  $\mathbf{z}_1$ . Hence, (6.6) is equivalent to

$$\begin{aligned} & \text{minimize } J_{1,2}(\mathbf{u}_1) \\ & \text{subject to} \\ & \begin{cases} x_1(k) = A_1 x_1(k-1) \oplus B_1 u_1(k) \\ \tilde{\mathbf{z}}_1(k) \geq C_1 x_1(k) \\ \mathbf{u}_1(k+1) \geq \mathbf{u}_1(k) \end{cases} \quad \text{for } 0 \leq k < K \\ & x_1(-1) = \varepsilon, \mathbf{u}_1(0) \geq \mathbf{e}, \mathbf{u}_1(K) = \top \end{aligned} \quad (6.7)$$

As  $\mathbf{u}_1^I \geq \mathbf{u}_1^{\text{II}}$  implies  $J_{1,2}(\mathbf{u}_1^I) \leq J_{1,2}(\mathbf{u}_1^{\text{II}})$ , the optimal cost in (6.6) is reached for the optimal input obtained in § 6.1.1. Therefore, the optimal input computed in § 6.1.1 is optimal with respect to the just-in-time criterion under an optimal cost for the tardiness criterion.

### Secondary System

The previous approach is directly transposed to the secondary system under a predefined behavior of the main system. Hence, for the secondary system, the optimal input obtained in § 6.1.1 is optimal with respect to the just-in-time criterion under an optimal cost for the tardiness criterion.

**Remark 21.** In optimal control or model predictive control [20], the cost function has sometimes the form  $J_1(\mathbf{y}) + \beta J_2(\mathbf{u})$  where

- $J_1$  is a cost function quantifying the tracking error
- $J_2$  is a cost function quantifying the input effort
- $\beta$  is an element in  $\mathbb{R}_0^+$  representing the trade-off between the cost functions  $J_1$  and  $J_2$ . In practice,  $\beta$  is often selected small but strictly positive.

The objective is to compute the input  $\mathbf{u}$  minimizing the overall cost function according to the dynamics of the system. Intuitively, our problem for the main system or the secondary system is similar, but the parameter  $\beta$  is assumed to be infinitesimal.

### 6.1.3. Complexity

The computation time of the optimal input for the main system is obtained by solving the backward recursive relation (6.2) over the event horizon of length  $K$ . As the computation time associated with each step is constant with respect to the length  $K$  of the event horizon, the computation time of the optimal input for the main system is linear with the length  $K$  of the event horizon. The computation time of the optimal input for the secondary system is obtained by solving the backward recursive relation (6.4) over the event horizon of length  $K$ . However, the computation time associated with each step may not be constant with respect to the length  $K$  of the event horizon, as the computation of  $\Phi_i^\#(\chi)$  for  $\chi \in \overline{\mathbb{R}}_{\max}$  (necessary

for the mappings F and G) may depend on the length K of the event horizon. But, it is possible to come down to a constant time in average over occurrence index k by reusing information from the previous step. Hence, the computation time of the optimal input for the secondary system is linear with the length K of the event horizon. Therefore, the computation time of the optimal input for a (max, +)-system with partial synchronization is linear with the length K of the event horizon.

To compute the realizable optimal input, it is only necessary to precede the solving of the backward recursive relation by the solving of a forward recursive relation over the event horizon of length K. The aim of this preliminary step is to relax the output reference. Using a reasoning similar to the one presented before, the computation time associated with this preliminary step is linear with the length K of the event horizon. Hence, the computation time of the realizable optimal input for a (max, +)-system with partial synchronization is linear with the length K of the event horizon.

**Example 33.** *Let us consider Ex. 23 with the output reference*

$$z_{1,1}(k) = z_{1,2}(k) = \begin{cases} \varepsilon & \text{for } k < 0 \\ 10 \otimes 20^k & \text{for } 0 \leq k < K \\ \top & \text{for } k \geq K \end{cases}$$

$$z_{2,1}(k) = z_{2,2}(k) = \begin{cases} \varepsilon & \text{for } k < 0 \\ 20 \otimes 80^k & \text{for } 0 \leq k < K \\ \top & \text{for } k \geq K \end{cases}$$

*A Scilab simulation leads to the following results for the computation time of the realizable optimal input.*

K	64	128	256
Computation time (in s)	1.39	2.59	5.04

*As expected, the computation time is linear with the length K of the event horizon.*

## 6.2. Model Predictive Control

Model predictive control (MPC) is a closed-loop version of optimal feedforward control. At each time step, an output reference for the next K occurrences of each output event is considered. Based on this output reference, an optimal input is computed with a method similar to the one presented in § 6.1.1. Then, this optimal input is used to implement occurrences of input events during the next time step. The main difficulty in comparison with optimal feedforward control is to consider the history of the system. The advantage of this control approach is the ability to take into account changes in the output reference

(e.g., changes in the schedule) and perturbations. The drawback is the cost associated with the online computation of the optimal input and the additional communication network necessary to update information online.

Let us now examine the precise timing of this control approach. At time  $t$ , the behavior of the system before time  $t$  and the timing pattern of the input events over the time interval  $[t, t + 1[$  are known. Based on this information and on the output reference, an optimal input is computed using a method similar to the one presented in § 6.1.1. As this step has to be done during the time interval  $[t, t + 1[$ , the associated computation time is crucial: a computation time linear with the length  $K$  of the event horizon is achieved. Then, the computed optimal input is used to determine the timing pattern of the input events over the time interval  $[t + 1, t + 2[$ . Hence, the information necessary to start again the process at time  $t + 1$  is available at time  $t + 1$ . In practice, the occurrence times of input events during the time interval  $[0, 1[$  has to be guessed or computed offline, as they cannot come from the previous step.

The link between the time domain and the event domain is formalized, for event  $e$ , by the parameter  $K_{t,e}$  defined as the index of the first occurrence of event  $e$  after or at time  $t$ . At time  $t$ ,  $e(k)$  is known for  $k < K_{t,e}$ , as it corresponds to a past occurrence of event  $e$ , and  $e(k) \geq t$  for  $k \geq K_{t,e}$ . Furthermore, as the timing pattern of an input event, denoted  $v$ , over the time interval  $[t, t + 1[$  is known at time  $t$ ,  $v(k)$  is known, at time  $t$ , for  $k < K_{t+1,v}$ . The output reference considered at time  $t$ , denoted  $z^t$ , is defined by

$$z_j^t(k) = \begin{cases} y_j(k) & \text{for } k < K_{t,y_j} \\ z_j(k) \oplus t & \text{for } K_{t,y_j} \leq k < K_{t,y_j} + K \\ \top & \text{for } k \geq K_{t,y_j} + K \end{cases}$$

where  $z$  is the required output reference.

In the following, a method to compute the optimal input at time  $t$  is presented. As before, the problem is first solved for the main system by neglecting the secondary system and, second, for the secondary system under a predefined behavior of the main system.

### Main System

The main system is described by

$$\begin{cases} x_1(k) = A_1 x_1(k-1) \oplus B_1 u_1(k) \\ y_1(k) = C_1 x_1(k) \end{cases}$$

The output reference associated, at time  $t$ , with the main system, denoted  $z_1^t$ , is defined by

$$z_{1,j}^t(k) = \begin{cases} y_{1,j}(k) & \text{for } k < K_{t,y_{1,j}} \\ z_{1,j}(k) \oplus t & \text{for } K_{t,y_{1,j}} \leq k < K_{t,y_{1,j}} + K \\ \top & \text{for } k \geq K_{t,y_{1,j}} + K \end{cases}$$

The first task consists in identifying the occurrences of input and state events in the main system affecting the next  $K$  occurrences of output events in the main system. Let us consider state event  $x_{1,j}$  and output event  $y_{1,i}$ . In the following discussion, two cases are distinguished.

**First case:**  $K_{t,y_{1,i}} \leq K_{t,x_{1,j}}$ . Due to the structure of the model,  $y_{1,i}(k)$  is not affected by  $x_{1,j}(l)$  for  $l > k$ . Hence, as  $K_{t,y_{1,i}} + K - 1 < K_{t,x_{1,j}} + K$ , the next  $K$  occurrences of output event  $y_{1,i}$  are not affected by occurrences  $k$  of state event  $x_{1,j}$  with  $k \geq K_{t,x_{1,j}} + K$ . Thus, to capture the influence of state event  $x_{1,j}$  on the next  $K$  occurrences of output event  $y_{1,i}$ , it is sufficient to predict the timing pattern of state event  $x_{1,j}$  over  $K_{t,x_{1,j}} \leq k < K_{t,x_{1,j}} + K$ .

**Second case:**  $K_{t,y_{1,i}} > K_{t,x_{1,j}}$ . Due to the model,

$$\forall l \in \mathbb{N}_0, \quad y_{1,i}(K_{t,y_{1,i}} - 1) \geq (C_1 A_1^l)_{ij} x_{1,j}(K_{t,y_{1,i}} - l - 1)$$

Thus, for  $0 \leq l \leq K_{t,y_{1,i}} - K_{t,x_{1,j}} - 1$ ,  $(C_1 A_1^l)_{ij} = \varepsilon$ , as  $y_{1,i}(K_{t,y_{1,i}} - 1) < t$  and  $x_{1,j}(K_{t,y_{1,i}} - 1 - l) \geq x_{1,j}(K_{t,x_{1,j}}) \geq t$ . Therefore,  $y_{1,i}(k)$  is not affected by  $x_{1,j}(l)$  for  $l > k - K_{t,y_{1,i}} + K_{t,x_{1,j}}$ . Thus, to capture the influence of state event  $x_{1,j}$  on the next  $K$  occurrences of output event  $y_{1,i}$ , it is sufficient to predict the timing pattern of state event  $x_{1,j}$  over  $K_{t,x_{1,j}} \leq k < K_{t,x_{1,j}} + K$ .

A similar reasoning can be applied to input events. Let us consider input event  $u_{1,j}$  and output event  $y_{1,i}$ . To capture the influence of input event  $u_{1,j}$  on the next  $K$  occurrences of output event  $y_{1,i}$ , it is sufficient to predict the timing pattern of input event  $u_{1,j}$  over  $K_{t,u_{1,j}} \leq k < K_{t,u_{1,j}} + K$ .

A direct consequence of the previous discussion is that the predicted state, input, and output of the main system, denoted  $\hat{x}_1$ ,  $\hat{u}_1$ , and  $\hat{y}_1$ , are considered over a finite event horizon of length  $K$  and set to  $\top$  after this horizon. Hence,

$$\begin{aligned} \hat{x}_{1,i}(k) &= \begin{cases} x_{1,i}(k) & \text{for } k < K_{t,x_{1,i}} \\ \top & \text{for } k \geq K_{t,x_{1,i}} + K \end{cases} \\ \hat{u}_{1,i}(k) &= \begin{cases} u_{1,i}(k) & \text{for } k < K_{t+1,u_{1,i}} \\ \top & \text{for } k \geq K_{t,u_{1,i}} + K \end{cases} \\ \hat{y}_{1,i}(k) &= \begin{cases} y_{1,i}(k) & \text{for } k < K_{t,y_{1,i}} \\ \top & \text{for } k \geq K_{t,y_{1,i}} + K \end{cases} \end{aligned}$$

As occurrences of input events over time interval  $[t, t + 1[$  have been determined with this method,  $K_{t+1,u_{1,i}} \leq K_{t,u_{1,i}} + K$ . If  $K_{t+1,u_{1,i}} = K_{t,u_{1,i}} + K$ , no occurrences of input events during the time interval  $[t + 1, t + 2[$  are required and the process is completed. Hence, only the case  $K_{t+1,u_{1,i}} < K_{t,u_{1,i}} + K$  is investigated.



The problem is then to efficiently fill in the event window with unknown entries for each dater. To solve this problem, a method similar to the one presented in § 6.1.1 is used. Notice that  $\hat{x}_1$ ,  $\hat{u}_1$ , and  $\hat{y}_1$  may not represent a valid future behavior of the system, but they will be selected such that they respect its dynamics for the event occurrences affecting the next  $K$  occurrences of output events.

The first step consists in finding the least feasible output reference greater than or equal to  $z_1^t$ , denoted  $\tilde{z}_1^t$ . The least realizable input, denoted  $\hat{u}_1^t$ , is defined by

$$\hat{u}_{1,i}^t(k) = \begin{cases} u_{1,i}(k) & \text{for } k < K_{t+1,u_{1,i}} \\ \perp & \text{for } K_{t+1,u_{1,i}} \leq k < K_{t,u_{1,i}} + K \\ \top & \text{for } k \geq K_{t,u_{1,i}} + K \end{cases}$$

The state induced by  $\hat{u}_{1,i}$ , denoted  $\hat{x}_{1,i}$ , is calculated by using the recurrence relation

$$x_1(k) = A_1 x_1(k-1) \oplus B_1 u_1(k)$$

A naive approach consists in computing this relation for  $K_{t,x_1} \leq k < \bar{K}_{t,x_1} + K$ , where  $K_{t,x_1} = \min(K_{t,x_{1,i}} | 1 \leq i \leq n_1)$  and  $\bar{K}_{t,x_1} = \max(K_{t,x_{1,i}} | 1 \leq i \leq n_1)$ . However, as  $\bar{K}_{t,x_1} - K_{t,x_1}$  might not be bounded, the computation time associated with this problem might grow to infinity. A better approach is to compute  $\hat{x}_1(k)$  only when at least one of its entries is unknown. This computation has to be done according to increasing occurrence indices, *i.e.*, the event windows with unknown entries have to be filled from left to right. Using this approach, the computation time to obtain  $\hat{x}_1$  is linear with the length  $K$  of the event horizon. The trick of computing only the needed value to fill in the event windows with unknown entries is used redundantly for model predictive control and allows us to obtain an overall computation time linear with the length  $K$  of the event horizon. Then, the unknown entries of  $\hat{y}_1$ , the output induced by  $\hat{u}_1$  are computed using  $y_1(k) = C_1 x_1(k)$ . Once again,  $\hat{y}_1(k)$  is computed only when at least one of its entries is unknown. This allows us to compute the least feasible output reference  $\tilde{z}_1^t$ , given by  $\tilde{z}_1^t = z_1^t \oplus \hat{y}_1$ . The computation time associated with this step is linear with the length  $K$  of the event horizon.

The second step consists in calculating the optimal input associated with output reference  $\tilde{z}_1^t$ . Using a similar reasoning, the predicted least upper bound for state events, denoted  $\hat{\zeta}_1$ , is partly known, *i.e.*,

$$\hat{\zeta}_{1,i}(k) = \begin{cases} x_{1,i}(k) & \text{for } k < K_{t,x_{1,i}} \\ \top & \text{for } k \geq K_{t,x_{1,i}} + K \end{cases}$$

To fill in the event window with unknown entries, the recursive relation

$$\zeta_1(k) = A_1 \zeta_1(k+1) \wedge C_1 z_1(k)$$

is considered. However, as for the calculation of  $\hat{x}_1$ ,  $\hat{\zeta}_1(k)$  is only computed when at least one of its entries is unknown to maintain a computation time linear with the length  $K$  of the

event horizon. This computation has to be done according to decreasing occurrence indices, *i.e.*, the event windows with unknown entries have to be filled from right to left. Finally, the optimal input is given by the relation  $u_1^*(k) = B_1^{-1} \zeta_1(k)$ . To maintain a computation time linear with the length  $K$  of the event horizon,  $\hat{u}_1(k)$  is computed only when at least one of its entries is unknown. The computation time associated with this step is linear with the length  $K$  of the event horizon.

### Secondary System

The secondary system is described by

$$\begin{cases} x_2(k) = H(x_2(k-1), u_2(k)) \\ y_2(k) = C_2 x_2(k) \end{cases}$$

The output reference associated, at time  $t$ , with the main system, denoted  $z_2^t$ , is defined by

$$z_{2,j}^t(k) = \begin{cases} y_{2,j}(k) & \text{for } k < K_{t,y_{2,j}} \\ z_{2,j}(k) \oplus t & \text{for } K_{t,y_{2,j}} \leq k < K_{t,y_{2,j}} + K \\ \top & \text{for } k \geq K_{t,y_{2,j}} + K \end{cases}$$

The first task consists in identifying the occurrences of input and state events in the secondary system affecting the next  $K$  occurrences of output events in the secondary system. As the only synchronizations between events in the secondary system are standard synchronizations, it is possible to discard partial synchronizations for this task and apply the method used for the main system. Hence, to capture the influence of state event  $x_{2,j}$  (resp. input event  $u_{2,j}$ ) on the next  $K$  occurrences of output event  $y_{2,i}$ , it is sufficient to predict the behavior of state event  $x_{2,j}$  (resp. input event  $u_{2,j}$ ) over  $K_{t,x_{2,j}} \leq k < K_{t,x_{2,j}} + K$  (resp.  $K_{t,u_{2,j}} \leq k < K_{t,u_{2,j}} + K$ ).

The remaining part of optimal input calculation consists in adapting the method developed in § 6.1 to the moving event horizon. This problem is very similar to the one solved for the main system and is not discussed further. The computation time associated with the calculation of the optimal input for the secondary system under a predefined behavior of the main system is linear with the length  $K$  of the event horizon. Hence, the overall computation time to compute the optimal input at time  $t$  is linear with the length  $K$  of the event horizon.

**Remark 22.** *A formulation of the previous control approach with cost functions is direct by using the characterization of optimal feedforward control in terms of cost functions developed in § 6.1.2. Furthermore, in standard MPC, a prediction horizon  $K_p$  is considered, but the input is only optimized over a control horizon  $K_u \leq K_p$ . This lowers the computation time associated with the optimization problem solved online. In our approach, due to backward recursive*

relations,  $K = K_p = K_u$  and it is not possible to choose  $K_u < K_p$ . However, reducing the computational time might be unnecessary, as the computation time to solve online the optimization problem is linear with the length  $K$  of the prediction horizon.

**Example 34.** The example introduced in Ex. 23 (i.e., the supply chain) is considered with a simulation time horizon  $T = 800$  and a prediction event horizon of length  $K = 4$  (unless otherwise specified).

**Reference case:** The output references are given by

$$z_{1,1}(k) = z_{1,2}(k) = \begin{cases} \varepsilon & \text{if } k < 0 \\ 15 \otimes 20^k & \text{if } k \geq 0 \end{cases}$$

$$z_{2,1}(k) = \begin{cases} \varepsilon & \text{if } k < 0 \\ 20 \otimes 80^k & \text{if } k \geq 0 \end{cases} \quad \text{and} \quad z_{2,2}(k) = \begin{cases} \varepsilon & \text{if } k < 0 \\ 55 \otimes 80^k & \text{if } k \geq 0 \end{cases}$$

The input provided by MPC is

$$u_{1,1}(k) = u_{1,2}(k) = \begin{cases} \varepsilon & \text{if } k < 0 \\ 5 \otimes 20^k & \text{if } 0 \leq k < 40 \\ T & \text{if } k \geq 40 \end{cases}$$

$$u_{2,1}(k) = \begin{cases} \varepsilon & \text{if } k < 0 \\ 20 \otimes 80^k & \text{if } 0 \leq k < 10 \\ T & \text{if } k \geq 10 \end{cases} \quad \text{and} \quad u_{2,2}(k) = \begin{cases} \varepsilon & \text{if } k < 0 \\ 60 \otimes 80^k & \text{if } 0 \leq k < 10 \\ T & \text{if } k \geq 10 \end{cases}$$

This input corresponds to the optimal input obtained with the method presented in § 6.1.1 by truncating the output reference at  $k = 40$  and forcing the input events to occur after or at time  $t = 1$  (this last condition is required by the timing of MPC). Hence, the length of the prediction horizon is sufficient to predict the behavior of the system.

**Complexity analysis:** The reference case is run with different lengths  $K$  for the prediction horizon. A Scilab implementation leads to the following computation time to solve the optimization problem for a single time step.

K	4	8	16
Computation time (in s)	2.05	4.09	8.18

As expected, the computation time is linear with the length  $K$  of the prediction horizon.

**Change in the output reference:** Output reference  $z_1$  starts with a throughput of one train every 20 units of time. At  $t = 200$ , the throughput is suddenly increased to one train every 15 units of time. Output reference  $z_2$  is the same than in the reference case. The input provided by MPC is

$$u_{1,1}(k) = u_{1,2}(k) = \begin{cases} \varepsilon & \text{if } k < 0 \\ 5 \otimes 20^k & \text{if } 0 \leq k < 10 \\ 201 \otimes 12^{k-10} & \text{if } 10 \leq k < 16 \\ 275 \otimes 15^{k-16} & \text{if } 16 \leq k < 52 \\ \top & \text{if } k \geq 52 \end{cases}$$

$$u_{2,1}(k) = \begin{cases} \varepsilon & \text{if } k < 0 \\ 20 \otimes 80^k & \text{if } 0 \leq k < 3 \\ 232 & \text{if } k = 3 \\ 285 \otimes 60^{k-4} & \text{if } 4 \leq k < 13 \\ \top & \text{if } k \geq 13 \end{cases} \quad \text{and } u_{2,2}(k) = \begin{cases} \varepsilon & \text{if } k < 0 \\ 60 \otimes 80^k & \text{if } 0 \leq k < 2 \\ 208 \otimes 48^{k-2} & \text{if } 2 \leq k < 4 \\ 315 \otimes 60^{k-4} & \text{if } 4 \leq k < 13 \\ \top & \text{if } k \geq 13 \end{cases}$$

After  $t = 200$ , the main system operates at the maximal throughput (i.e., one train every 12 units of time) to catch up with the new output reference. Afterwards, the main system takes the correct throughput (i.e., one train every 15 units of time). But, the secondary system drifts: the throughput increases to one container every 60 units of times after the change in the output reference instead of staying at one container every 80 units of time. This is due to a prediction horizon too short with respect to the new throughput of the train line. Indeed, if we consider a prediction horizon of length  $K = 5$ . The input  $u_1$  remains the same, but  $u_2$  is given by

$$u_{2,1}(k) = \begin{cases} \varepsilon & \text{if } k < 0 \\ 20 \otimes 80^k & \text{if } 0 \leq k < 3 \\ 232 & \text{if } k = 3 \\ 315 \otimes 75^{k-4} & \text{if } 4 \leq k < 6 \\ 480 \otimes 75^{k-6} & \text{if } 6 \leq k < 9 \\ 720 \otimes 75^{k-9} & \text{if } 9 \leq k < 11 \\ \top & \text{if } k \geq 11 \end{cases} \quad \text{and } u_{2,2}(k) = \begin{cases} \varepsilon & \text{if } k < 0 \\ 60 \otimes 80^k & \text{if } 0 \leq k < 2 \\ 208 & \text{if } k = 2 \\ 270 \otimes 75^{k-3} & \text{if } 3 \leq k < 5 \\ 435 \otimes 75^{k-5} & \text{if } 5 \leq k < 8 \\ 675 \otimes 75^{k-8} & \text{if } 8 \leq k < 10 \\ \top & \text{if } k \geq 10 \end{cases}$$

With a longer prediction horizon, the throughput of the secondary systems remains at one train every 80 units of time after the change in the output reference.

**Perturbation:** The reference case is considered, but a perturbations delays the third occurrence of event  $x_{1,4}$  (i.e., the arrival in train station B) until  $t = 80$ . This might be caused by

an unexpected mechanical breakdown. The input provided by MPC is

$$u_{1,1}(k) = u_{1,2}(k) = \begin{cases} \varepsilon & \text{if } k < 0 \\ 5 \otimes 20^k & \text{if } 0 \leq k < 2 \\ 82 \otimes 10^{k-2} & \text{if } 2 \leq k < 4 \\ 106 \otimes 10^{k-4} & \text{if } 4 \leq k < 6 \\ 130 & \text{if } k = 6 \\ 145 \otimes 20^{k-7} & \text{if } 7 \leq k < 40 \\ \top & \text{if } k \geq 40 \end{cases}$$

$$u_{2,1}(k) = \begin{cases} \varepsilon & \text{if } k < 0 \\ 20 & \text{if } k = 0 \\ 125 & \text{if } k = 1 \\ 200 \otimes 80^{k-2} & \text{if } 2 \leq k < 10 \\ \top & \text{if } k \geq 10 \end{cases} \quad \text{and } u_{2,2}(k) = \begin{cases} \varepsilon & \text{if } k < 0 \\ 89 & \text{if } k = 0 \\ 160 \otimes 80^{k-1} & \text{if } 1 \leq k < 10 \\ \top & \text{if } k \geq 10 \end{cases}$$

After the perturbation at  $t = 80$ , the main system operates at the maximal throughput (i.e., one train every 12 units of time) to catch up with the output reference. The secondary system takes these changes in the behavior of the main system into account.



## Operatorial Representation

---

In this chapter, operatorial representation for  $(\max, +)$ -systems with partial synchronization is discussed. The principle of operatorial representation is to model the dynamics of the system by mappings over daters. This approach has been successfully applied to  $(\max, +)$ -linear systems [1, 8, 22, 32] and extended to take into account event batching [10, 15, 16]. The main outcome of operatorial representation for  $(\max, +)$ -linear systems is a concept equivalent to transfer function matrices in standard control theory. Furthermore, a handy mathematical representation for the class of operators appearing in  $(\max, +)$ -linear systems is provided by the dioid  $\overline{\mathbb{N}}_{\max, \gamma}[\![\gamma]\!]$  recalled in § 2.7. Unfortunately, an operatorial representation for  $(\max, +)$ -systems with partial synchronization does not exist. However, it is still possible to capture some dynamics using this method. In particular, an operatorial representation for the secondary system under a predefined behavior of the main system is obtained. In the following, such systems are called  $(\max, +)$ -systems subject to partial synchronization. Note that a  $(\max, +)$ -linear system is a  $(\max, +)$ -system subject to partial synchronization, as a  $(\max, +)$ -linear system corresponds to a secondary system, which is not subject to any partial synchronizations. Hence,  $(\max, +)$ -systems subject to partial synchronization form a larger class of systems than  $(\max, +)$ -linear systems. A suitable algebraic structure for this operatorial representation is the dioid  $\mathcal{F}_{\overline{\mathbb{N}}_{\max, \gamma}[\![\gamma]\!]}$  introduced in § 4. In practice,  $(\max, +)$ -systems subject to partial synchronization appear when the input of the main system is known and perturbations affecting the main system are unlikely. Hence, the dynamics of the main system can be neglected and predetermined synchronizing daters are considered in partial synchronizations. From now on, we assume

that the considered discrete event systems are time-driven (*i.e.*, events only occur at clock ticks). This assumption is also made in operatorial representation for  $(\max, +)$ -linear systems and allows us to only consider standard synchronizations with a time delay  $\tau \in \mathbb{N}_0$  (while, previously,  $\tau \in \mathbb{R}_0^+$ ) and daters in  $\overline{\mathbb{N}}_{\max, \gamma}[\gamma]$ . In this chapter, the discussed results are mainly illustrated with Ex. 35 described below.

**Example 35.** *This example deals with a one-way road from A to C via B. The road is equipped with two traffic lights in B and in C. The traffic light B allows other users such as pedestrians or trains to cross the road, but is not regulating an intersection with another road. Therefore, a vehicle entering the road in A passes through B and leaves the road in C. Next, the characteristics of the road are made explicit. The travel time from A to B or from B to C is ten units of time. The capacity of each section (*i.e.*, from A to B or from B to C) is three vehicles. When the traffic light is green, at most one vehicle can pass the traffic light per unit of time. Furthermore, the behavior of the traffic lights is known: each traffic light is green for  $t \in \text{Im}(d) \cup \{\top\}$  where  $d = (e \oplus 1\gamma \oplus 2\gamma^2) (6\gamma^3)^*$ . Initially, no vehicles are on the road.*

*In the following, the system is modeled by a discrete event system ruled by synchronization. The model is based on the following events:*

*u a vehicle arrives on the road*

*$x_1, x_2, x_3$  a vehicle passes respectively through A, B, C*

*y a vehicle leaves the road*

*The previous description of the system corresponds to the following synchronizations:*

- for all  $k \geq 0$ , occurrence  $k$  of event  $x_2$  (resp.  $x_3$ ) is at least ten units of time after occurrence  $k$  of event  $x_1$  (resp.  $x_2$ )*
- for all  $k \geq 1$ , occurrence  $k$  of event  $x_2$  (resp.  $x_3$ ) is at least one unit of time after occurrence  $k - 1$  of event  $x_2$  (resp.  $x_3$ )*
- for all  $k \geq 3$ , occurrence  $k$  of event  $x_1$  (resp.  $x_2$ ) is at least zero units of time after occurrence  $k - 3$  of event  $x_2$  (resp.  $x_3$ )*
- for all  $k \geq 0$ , occurrence  $k$  of event  $x_1$  (resp.  $y$ ) is at least zero units of time after occurrence  $k$  of event  $u$  (resp.  $x_3$ )*
- event  $x_2$  (resp.  $x_3$ ) can only occur at  $t \in \text{Im}(d) \cup \{\top\}$*

*A graphical representation of the road is given in Fig. 7.1. The dynamics of the main system (*i.e.*, the traffic lights) is completely neglected and the partial synchronizations are only using the predefined dater  $d$  as timing pattern of the synchronizing events. Hence, this system is a  $(\max, +)$ -system subject to partial synchronization.*

## 7.1. Algebraic Definition of Operatorial Representation

In the following, a general presentation of operatorial representation is made. Daters have been defined in § 5.2.1 as isotone mappings from  $\mathbb{Z}$  to  $\overline{\mathbb{N}}_{\max}$  (not to  $\overline{\mathbb{R}}_{\max}$ , as a time-



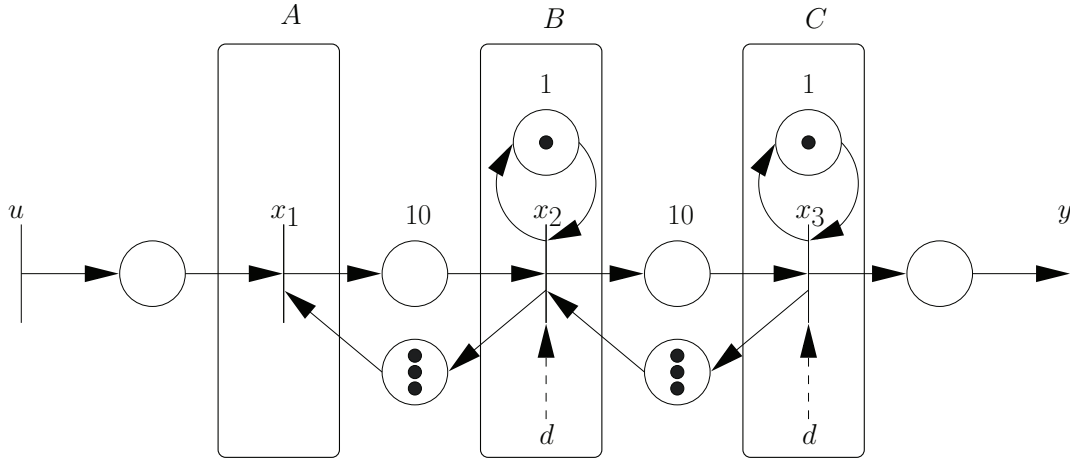

Figure 7.1.: Petri net representation of the road equipped with traffic lights

driven dynamics is assumed) equal to  $\varepsilon$  over  $\{k \in \mathbb{Z} | k < 0\}$ . The set of daters is denoted  $\mathcal{D}$ . Let us now formally define operators.

**Definition 50** (Operator). *An operator is a residuated mapping over the set of daters.*

**Example 36** (Operator  $\gamma$ ). *An operator of interest is the shift in the event domain denoted  $\gamma$  and defined by*

$$\forall d \in \mathcal{D}, \forall k \in \mathbb{Z}, \quad \gamma(d)(k) = d(k-1)$$

The residual of the operator  $\gamma$ , denoted  $\gamma^\sharp$ , is defined by

$$\forall d \in \mathcal{D}, \forall k \in \mathbb{Z}, \quad \gamma^\sharp(d)(k) = \begin{cases} \varepsilon & \text{for } k < 0 \\ d(k+1) & \text{for } k \geq 0 \end{cases}$$

**Proposition 39.** *The set of operators, denoted  $\mathcal{O}$ , endowed with the operations  $\oplus$  and  $\otimes$  defined by*

$$\begin{aligned} \forall o_1, o_2 \in \mathcal{O}, \quad \forall d \in \mathcal{D}, \quad (o_1 \oplus o_2)(d) &= o_1(d) \oplus o_2(d) \\ o_1 \otimes o_2 &= o_1 \circ o_2 \end{aligned}$$

is a complete dioid.

*Proof.* As  $\mathcal{D}$  is a complete dioid (a possible operation  $\otimes$  to obtain a dioid is the Cauchy product), this proposition is a direct consequence of Prop. 5.  $\square$

According to § 2.4, matrices of operators are endowed with operations  $\oplus$  and  $\otimes$ . Furthermore, the set of square matrices with entries in  $\mathcal{O}$  is a complete dioid. The following definition gives a meaning to matrices of operators.

**Definition 51** (Matrix of operators). *Let  $O \in \mathcal{O}^{m \times n}$ . Matrix  $O$  denotes a mapping from  $\mathcal{D}^n$  to  $\mathcal{D}^m$  defined by*

$$\forall d \in \mathcal{D}^n, \quad O(d)_i = \bigoplus_{j=1}^n O_{ij}(d_j)$$

**Lemma 46.** *Let  $O \in \mathcal{O}^{m \times n}$ . Mapping  $O$  is residuated.*

*Proof.* Obviously, mapping  $O$  is isotone. Let  $z \in \mathcal{D}^m$ .

$$\begin{aligned} O(x) \leq z &\Leftrightarrow \forall i, \quad O(x)_i \leq z_i \\ &\Leftrightarrow \forall i, j, \quad O_{ij}(x_j) \leq z_i \\ &\Leftrightarrow \forall i, j, \quad x_j \leq O_{ij}^\#(z_i) \\ &\Leftrightarrow \forall j, \quad x_j \leq \bigwedge_{i=1}^m O_{ij}^\#(z_i) \end{aligned}$$

Therefore, the inequality  $O(x) \leq z$  admits a greatest solution. Hence, mapping  $O$  is residuated.  $\square$

Finally, the previous definitions allow us to formalize what is meant by operatorial representation.

**Definition 52** (Operatorial representation). *Let  $\mathcal{S}$  be a discrete event system ruled by synchronization, such that its event set is partitioned into  $n$  state events, denoted  $x_1, \dots, x_n$ ,  $m$  input events, denoted  $u_1, \dots, u_m$ , and  $p$  output events, denoted  $y_1, \dots, y_p$ . The system  $\mathcal{S}$  admits an operatorial representation if there exist  $A \in \mathcal{O}^{n \times n}$ ,  $B \in \mathcal{O}^{n \times m}$ , and  $C \in \mathcal{O}^{p \times n}$  such that the admissible behaviors are characterized by*

$$\begin{cases} x \geq A(x) \oplus B(u) \\ y \geq C(x) \end{cases}$$

### 7.1.1. Transfer Function Matrix

In the following, an input-output mapping, called transfer function matrix due to similarities with standard control theory, is derived from the operatorial representation. This reasoning is based on an analogy with Th. 5. The first step consists in finding the least (as the earliest functioning rule is considered) solution of

$$x \geq A(x) \oplus B(u)$$

Let us consider the vector of daters  $\mathcal{A}^*\mathcal{B}(\mathbf{u})$ . This is a solution, as

$$\begin{aligned} \mathcal{A}(\mathcal{A}^*\mathcal{B}(\mathbf{u})) \oplus \mathcal{B}(\mathbf{u}) &= \mathcal{A}\left(\bigoplus_{k=0}^{+\infty} \mathcal{A}^k\mathcal{B}(\mathbf{u})\right) \oplus \mathcal{B}(\mathbf{u}) \\ &= \bigoplus_{k=0}^{+\infty} \mathcal{A}^{k+1}\mathcal{B}(\mathbf{u}) \oplus \mathcal{B}(\mathbf{u}) \text{ as } \mathcal{A} \text{ is lower semi-continuous} \\ &= \mathcal{A}^*\mathcal{B}(\mathbf{u}) \end{aligned}$$

Furthermore, by induction, we prove that  $x \geq \mathcal{A}^k\mathcal{B}(\mathbf{u})$  for all  $k \in \mathbb{N}_0$ . For  $k = 0$ ,  $x \geq \mathcal{B}(\mathbf{u})$ , as  $x \geq \mathcal{A}(x) \oplus \mathcal{B}(\mathbf{u})$ . Let us now assume that, for  $k \geq 0$ ,  $x \geq \mathcal{A}^k\mathcal{B}(\mathbf{u})$ . Then,

$$\begin{aligned} x &\geq \mathcal{A}(x) \oplus \mathcal{B}(\mathbf{u}) \\ &\geq \mathcal{A}\left(\mathcal{A}^k\mathcal{B}(\mathbf{u})\right) \text{ as } \mathcal{A} \text{ is isotone} \\ &\geq \mathcal{A}^{k+1}\mathcal{B}(\mathbf{u}) \end{aligned}$$

This completes the induction. Hence, for all  $k \in \mathbb{N}_0$ ,  $x \geq \mathcal{A}^k\mathcal{B}(\mathbf{u})$ . Thus,  $x \geq \mathcal{A}^*\mathcal{B}(\mathbf{u})$ . Consequently, the least solution of  $x \geq \mathcal{A}(x) \oplus \mathcal{B}(\mathbf{u})$  is  $\mathcal{A}^*\mathcal{B}(\mathbf{u})$ . This leads directly to a transfer function matrix, denoted  $\mathcal{H}$ , such that  $\mathbf{y} \geq \mathcal{H}(\mathbf{u})$  where  $\mathcal{H} = \mathcal{C}\mathcal{A}^*\mathcal{B}$ .

**Remark 23.** As  $\mathcal{H}$  is residuated,  $\mathcal{H}$  is isotone. Therefore, in general, operatorial representation is not suitable to represent  $(\max, +)$ -systems with partial synchronization, as the associated input-output mapping is not necessarily isotone (see Ex. 28).

### 7.1.2. Composition Operators

In the following, a particular class of operators, namely composition operators, is defined based on the dioid  $\mathcal{F}_{\overline{\mathbb{N}}_{\max}}$  introduced in § 3. First, a lemma provides the theoretical foundation to the definition of composition operators.

**Lemma 47.** Let  $f$  be a mapping over  $\overline{\mathbb{N}}_{\max}$ . The following statements are equivalent:

1. mapping  $L_f$ , defined by  $L_f(d) = f \circ d$  for  $d \in \mathcal{D}$ , is an operator
2. mapping  $f$  is residuated

*Proof.* 1  $\Rightarrow$  2: Let  $d$  be a dater. As  $L_f(d)$  is a dater,

$$f(\varepsilon) = f(d(-1)) = L_f(d)(-1) = \varepsilon$$

Furthermore, let  $\mathcal{X} \subseteq \overline{\mathbb{N}}_{\max}$ . We associate to each element  $x$  in  $\overline{\mathbb{N}}_{\max}$  a dater  $d_x$  in  $\mathcal{D}$  such

that  $d_x(0) = x$ . Then,

$$\begin{aligned}
 f\left(\bigoplus_{x \in \mathcal{X}} x\right) &= f\left(\bigoplus_{x \in \mathcal{X}} d_x(0)\right) \\
 &= L_f\left(\bigoplus_{x \in \mathcal{X}} d_x\right)(0) \\
 &= \bigoplus_{x \in \mathcal{X}} L_f(d_x)(0) \text{ as } L_f \text{ is lower semi-continuous} \\
 &= \bigoplus_{x \in \mathcal{X}} f(x)
 \end{aligned}$$

Hence,  $f$  is lower semi-continuous. According to Th. 3,  $f$  is residuated.

$2 \Rightarrow 1$ : Let  $d$  be a dater. The first step consists in proving that  $L_f(d)$  is a dater. Obviously,  $L_f(d)$  is a mapping from  $\mathbb{Z}$  to  $\overline{\mathbb{N}}_{\max}$ . For  $k < 0$ ,

$$L_f(d)(k) = f(d(k)) = f(\varepsilon) = \varepsilon \text{ as } f \text{ is residuated}$$

Furthermore, as mappings  $f$  and  $d$  are isotone,  $L_f(d) = f \circ d$  is also isotone. Hence,  $L_f$  is a mapping over daters. It remains to check that  $L_f$  is residuated. Let us define the mapping  $g$  over  $\mathcal{D}$  by

$$\forall d \in \mathcal{D}, \forall k \in \mathbb{Z}, \quad g(d)(k) = \begin{cases} \varepsilon & \text{for } k < 0 \\ f^\sharp(d(k)) & \text{for } k \geq 0 \end{cases}$$

Mapping  $g$  is obviously an isotone mapping over  $\mathcal{D}$ . Furthermore,

$$\begin{aligned}
 \forall d \in \mathcal{D}, \forall k \in \mathbb{Z}, \quad (g \circ L_f)(d)(k) &= \begin{cases} \varepsilon & \text{for } k < 0 \\ f^\sharp(f(d(k))) & \text{for } k \geq 0 \end{cases} \\
 (L_f \circ g)(d)(k) &= \begin{cases} \varepsilon & \text{for } k < 0 \\ f(f^\sharp(d(k))) & \text{for } k \geq 0 \end{cases}
 \end{aligned}$$

As  $f^\sharp \circ f \geq \text{Id}_{\overline{\mathbb{N}}_{\max}}$  and  $f \circ f^\sharp \leq \text{Id}_{\overline{\mathbb{N}}_{\max}}$ ,

$$\forall d \in \mathcal{D}, \quad (g \circ L_f)(d) \geq d \text{ and } (L_f \circ g)(d) \leq d$$

Hence,  $g \circ L_f \geq \text{Id}_{\mathcal{D}}$  and  $L_f \circ g \leq \text{Id}_{\mathcal{D}}$ . Therefore, according to Th. 1,  $L_f$  is residuated.  $\square$

**Definition 53** (Composition operator). *An operator  $o$  is said to be a composition operator if there exists a mapping  $f \in \mathcal{F}_{\overline{\mathbb{N}}_{\max}}$  such that  $o = L_f$ .*

A composition operator simply composes a dater by a given mapping in  $\mathcal{F}_{\overline{\mathbb{N}}_{\max}}$ . Lem. 47 shows that composition operators are operators and that only composition by mappings in  $\mathcal{F}_{\overline{\mathbb{N}}_{\max}}$  leads to operators.

**Example 37** (Operator  $\delta$ ). A composition operator of interest is the shift in the time domain denoted  $\delta$  and defined by  $L_\Delta$ . The mapping  $\Delta$  in  $\mathcal{F}_{\overline{\mathbb{N}}_{\max}}$  has previously been introduced in § 3.2 and is defined by

$$\forall x \in \overline{\mathbb{N}}_{\max}, \quad \Delta(x) = 1x$$

The following lemma investigates the algebraic structure of the set of composition operators.

**Lemma 48.** The set of composition operators, denoted  $\mathcal{O}^C$ , is a complete subdioid of  $\mathcal{O}$ . Furthermore,  $\mathcal{O}^C$  and  $\mathcal{F}_{\overline{\mathbb{N}}_{\max}}$  are isomorphic.

*Proof.* First, we prove that  $\mathcal{O}^C$  is a complete subdioid of  $\mathcal{O}$ . The operator  $\varepsilon$  (resp.  $e$ ) is equal to  $L_\varepsilon$  (resp.  $L_e$ ). Hence,  $\varepsilon$  (resp.  $e$ ) belongs to  $\mathcal{O}^C$ . Let  $\mathcal{L} \subseteq \mathcal{O}^C$ . For  $o$  in  $\mathcal{L}$ ,  $f_o$  denotes a mapping in  $\mathcal{F}_{\overline{\mathbb{N}}_{\max}}$  such that  $o = L_{f_o}$ . Then,

$$\begin{aligned} \forall d \in \mathcal{D}, \forall k \in \mathbb{Z}, \quad \left( \bigoplus_{o \in \mathcal{L}} o \right) (d)(k) &= \bigoplus_{o \in \mathcal{L}} o(d)(k) \\ &= \bigoplus_{o \in \mathcal{L}} f_o(d)(k) \\ &= F(d)(k) \text{ where } F = \bigoplus_{o \in \mathcal{L}} f_o \\ &= L_F(d)(k) \text{ as } F \text{ belongs to } \mathcal{F}_{\overline{\mathbb{N}}_{\max}} \end{aligned}$$

Therefore,  $\bigoplus_{o \in \mathcal{L}} o$  belongs to  $\mathcal{O}^C$ . Thus,  $\mathcal{O}^C$  is closed under infinite sum. Furthermore, for the composition operators  $L_{f_1}$  and  $L_{f_2}$ ,

$$\begin{aligned} \forall d \in \mathcal{D}, \quad (L_{f_1} \otimes L_{f_2})(d) &= (f_1 \otimes f_2) \circ d \\ &= L_{f_1 \otimes f_2}(d) \end{aligned}$$

Hence, as  $f_1 \otimes f_2$  belongs to  $\mathcal{F}_{\overline{\mathbb{N}}_{\max}}$ ,  $\mathcal{O}^C$  is closed for the product. Thus,  $\mathcal{O}^C$  is a complete subdioid of  $\mathcal{O}$ .

Second, we prove that the mapping  $\Phi$ , defined by  $\Phi(f) = L_f$ , is an homomorphism from the dioid  $\mathcal{F}_{\overline{\mathbb{N}}_{\max}}$  to the dioid  $\mathcal{O}^C$ . First of all,

$$\Phi(\varepsilon) = L_\varepsilon = \varepsilon \text{ and } \Phi(e) = L_e = e$$

Furthermore, for  $f_1, f_2 \in \mathcal{F}_{\overline{\mathbb{N}}_{\max}}$ ,

$$\begin{aligned} \forall d \in \mathcal{D}, \forall k \in \mathbb{Z}, \quad \Phi(f_1 \oplus f_2)(d)(k) &= L_{f_1 \oplus f_2}(d)(k) \\ &= (f_1 \oplus f_2)(d)(k) \\ &= f_1(d)(k) \oplus f_2(d)(k) \\ &= L_{f_1}(d)(k) \oplus L_{f_2}(d)(k) \\ &= (L_{f_1} \oplus L_{f_2})(d)(k) \\ &= (\Phi(f_1) \oplus \Phi(f_2))(d)(k) \end{aligned}$$

$$\begin{aligned}
 \forall d \in \mathcal{D}, \forall k \in \mathbb{Z}, \quad \Phi(f_1 \otimes f_2)(d)(k) &= L_{f_1 \otimes f_2}(d)(k) \\
 &= f_1(f_2(d(k))) \\
 &= L_{f_1}(f_2 \circ d)(k) \\
 &= L_{f_1}(L_{f_2}(d))(k) \\
 &= (L_{f_1} \otimes L_{f_2})(d)(k) \\
 &= (\Phi(f_1) \otimes \Phi(f_2))(d)(k)
 \end{aligned}$$

Hence,  $\Phi(f_1 \oplus f_2) = \Phi(f_1) \oplus \Phi(f_2)$  and  $\Phi(f_1 \otimes f_2) = \Phi(f_1) \otimes \Phi(f_2)$ . Thus,  $\Phi$  is an homomorphism.

Finally, it remains to prove that  $\Phi$  is bijective. By definition,  $\Phi$  is surjective. The injectivity of  $\Phi$  is shown by the following reasoning. Let  $f_1, f_2$  in  $\mathcal{F}_{\overline{\mathbb{N}}_{\max}}$  and consider a set of daters  $\{d_x | x \in \overline{\mathbb{N}}_{\max}\}$  such that, for all  $x \in \overline{\mathbb{N}}_{\max}$ ,  $d_x(0) = x$ . Then,

$$\begin{aligned}
 \Phi(f_1) = \Phi(f_2) &\Rightarrow \forall x \in \overline{\mathbb{N}}_{\max}, \Phi(f_1)(d_x)(0) = \Phi(f_2)(d_x)(0) \\
 &\Rightarrow \forall x \in \overline{\mathbb{N}}_{\max}, L_{f_1}(d_x)(0) = L_{f_2}(d_x)(0) \\
 &\Rightarrow \forall x \in \overline{\mathbb{N}}_{\max}, f_1(d_x(0)) = f_2(d_x(0)) \\
 &\Rightarrow \forall x \in \overline{\mathbb{N}}_{\max}, f_1(x) = f_2(x) \\
 &\Rightarrow f_1 = f_2
 \end{aligned}$$

□

An interesting property of composition operators is presented in the following lemma.

**Lemma 49.** *The operator  $\gamma$  commutes with all composition operators.*

*Proof.* Let  $L_f$  be a composition operator associated with a mapping  $f$  in  $\mathcal{F}_{\overline{\mathbb{N}}_{\max}}$ .

$$\begin{aligned}
 \forall d \in \mathcal{D}, \forall k \in \mathbb{Z}, \quad (\gamma \otimes L_f)(d)(k) &= L_f(d)(k-1) \\
 &= f(d(k-1)) \\
 &= f(\gamma(d)(k)) \\
 &= L_f(\gamma(d))(k) \\
 &= (L_f \otimes \gamma)(d)(k)
 \end{aligned}$$

Hence,  $\gamma \otimes L_f = L_f \otimes \gamma$ . □

The next proposition shows the interest of the dioid  $\mathcal{F}_{\overline{\mathbb{N}}_{\max}, \gamma} \llbracket \gamma \rrbracket$  to represent a particular class of operators.

**Proposition 40.** *The complete dioid spanned by  $\mathcal{O}^C \cup \{\gamma\}$ , denoted  $\mathcal{O}^{C, \gamma}$ , is isomorphic to  $\mathcal{F}_{\overline{\mathbb{N}}_{\max}, \gamma} \llbracket \gamma \rrbracket$ .*

*Proof.* The complete dioid spanned by  $\mathcal{O}^C \cup \{\gamma\}$  is, by definition, the least complete dioid containing  $\mathcal{O}^C \cup \{\gamma\}$ . According to Lem. 49, an element  $\mathfrak{o}$  in  $\mathcal{O}^{C,\gamma}$  can be written as

$$\mathfrak{o} = \bigoplus_{k=0}^{+\infty} \mathfrak{o}_k \gamma^k \text{ where } \mathfrak{o}_k \in \mathcal{O}^C$$

Furthermore, as  $\gamma \leq e$ ,  $\gamma^* = e$ . Hence,

$$\mathfrak{o} = \gamma^* \mathfrak{o} = \bigoplus_{k=0}^{+\infty} \left( \bigoplus_{j=0}^k \mathfrak{o}_j \right) \gamma^k = \bigoplus_{k=0}^{+\infty} \mathfrak{o}_{\gamma,k} \gamma^k$$

where  $\mathfrak{o}_{\gamma,k} = \bigoplus_{j=0}^k \mathfrak{o}_j$  belongs to  $\mathcal{O}^C$ . The previous notation leads directly to a bijective mapping  $\Phi$  from  $\mathcal{O}^{C,\gamma}$  to  $\mathcal{O}_{\gamma}^C[[\gamma]]$  defined by

$$\forall \mathfrak{o} \in \mathcal{O}^{C,\gamma}, \forall k \in \mathbb{Z}, \quad \Phi(\mathfrak{o})(k) = \mathfrak{o}_{\gamma,k}$$

Furthermore,

$$\begin{aligned} \Phi(\varepsilon) &= \varepsilon \text{ and } \Phi(e) = e \\ \forall \mathfrak{o}_1, \mathfrak{o}_2 \in \mathcal{O}^{C,\gamma}, \quad \Phi(\mathfrak{o}_1 \oplus \mathfrak{o}_2) &= \Phi(\mathfrak{o}_1) \oplus \Phi(\mathfrak{o}_2) \\ \forall \mathfrak{o}_1, \mathfrak{o}_2 \in \mathcal{O}^{C,\gamma}, \quad \Phi(\mathfrak{o}_1 \otimes \mathfrak{o}_2) &= \Phi(\mathfrak{o}_1) \otimes \Phi(\mathfrak{o}_2) \end{aligned}$$

Hence,  $\Phi$  is an isomorphism and the dioids  $\mathcal{O}^{C,\gamma}$  and  $\mathcal{O}_{\gamma}^C[[\gamma]]$  are isomorphic. According to Lem. 48,  $\mathcal{O}^C$  and  $\mathcal{F}_{\bar{\mathbb{N}}_{\max}}$  are isomorphic. Thus,  $\mathcal{O}^{C,\gamma}$  and  $\mathcal{F}_{\bar{\mathbb{N}}_{\max},\gamma}[[\gamma]]$  are isomorphic.  $\square$

In the following, we only consider operatorial representation where the entries of  $\mathcal{A}$ ,  $\mathcal{B}$ , and  $\mathcal{C}$  belong to  $\mathcal{O}^{C,\gamma}$ . This allows us to transpose these matrices in  $\mathcal{F}_{\bar{\mathbb{N}}_{\max},\gamma}[[\gamma]]$  and to apply the tools developed in § 4.

### Impulse Response

In the following, an interpretation in terms of system theory is given to the mapping  $\psi(s)$  associated with series  $s$  in  $\mathcal{F}_{\bar{\mathbb{N}}_{\max},\gamma}[[\gamma]]$ . Let us first recall that  $\psi(s)$  is a mapping from  $\bar{\mathbb{N}}_{\max}$  to  $\bar{\mathbb{N}}_{\max,\gamma}[[\gamma]]$  defined by

$$\forall x \in \bar{\mathbb{N}}_{\max}, \quad \psi(s)(x) = \bigoplus_{k=0}^{+\infty} s(k)(x) \gamma^k$$

Let us consider a SISO discrete event system with an operatorial representation where the entries of  $\mathcal{A}$ ,  $\mathcal{B}$ , and  $\mathcal{C}$  belong to  $\mathcal{F}_{\bar{\mathbb{N}}_{\max},\gamma}[[\gamma]]$ . As  $\mathcal{F}_{\bar{\mathbb{N}}_{\max},\gamma}[[\gamma]]$  is a complete dioid,  $\mathcal{H} = \mathcal{C}\mathcal{A}^*\mathcal{B}$  is a series in  $\mathcal{F}_{\bar{\mathbb{N}}_{\max},\gamma}[[\gamma]]$ . For  $(\max, +)$ -linear systems and  $(\max, +)$ -systems with

partial synchronization, an impulse for an event corresponds to all occurrences  $k \geq 0$  of the considered event at time 0 and is modeled by the dater  $e$  defined by

$$e(k) = \begin{cases} \varepsilon & \text{for } k < 0 \\ e & \text{for } k \geq 0 \end{cases}$$

Hence, for the considered SISO system,

$$\begin{aligned} \mathcal{H}(e) &= \bigoplus_{k=0}^{+\infty} \mathcal{H}(e)(k) \gamma^k \\ &= \bigoplus_{k=0}^{+\infty} \left( \bigoplus_{j=0}^{+\infty} \mathcal{H}(j) \gamma^j \right) (e)(k) \gamma^k \\ &= \bigoplus_{k=0}^{+\infty} \bigoplus_{j=0}^{+\infty} \mathcal{H}(j) (e(k-j)) \gamma^k \\ &= \bigoplus_{k=0}^{+\infty} \bigoplus_{j=0}^k \mathcal{H}(j) (e) \gamma^k \\ &= \bigoplus_{k=0}^{+\infty} \mathcal{H}(k) (e) \gamma^k \\ &= \psi(\mathcal{H})(e) \end{aligned}$$

Thus, the impulse response is directly given by  $\psi(\mathcal{H})(e)$ . In the same way, the dater  $\psi(\mathcal{H})(x)$  with  $x \in \mathbb{N}_0$  corresponds to the output induced when all occurrences  $k \geq 0$  of the input event are at time  $x$ .

In the following, we discuss how to use the previous results to compute the output induced by input  $u$ . The transfer function  $\mathcal{H}$  of a  $(\max, +)$ -linear system is both event-invariant (*i.e.*,  $\gamma\mathcal{H} = \mathcal{H}\gamma$ ) and time-invariant (*i.e.*,  $\delta\mathcal{H} = \mathcal{H}\delta$ ). Therefore, the input induced by  $u$  is equal to the  $(\max, +)$ -convolution of the impulse response and the input  $u$ . However, transfer functions in  $\mathcal{F}_{\overline{\mathbb{N}}_{\max, \gamma}}[[\gamma]]$  are still event-invariant, but, in general, they are not time-invariant. Therefore, the output induced by  $u$  cannot be simply obtained by  $(\max, +)$ -convoluting the impulse response and the input  $u$ . Next, a method to calculate the output induced by input  $u$  in this more general case is presented. First, as  $u$  belongs to  $\overline{\mathbb{N}}_{\max, \gamma}[[\gamma]]$ , it is possible to associate to  $u$  a series  $\mathcal{U} = \Phi(u)$  in  $\mathcal{F}_{\overline{\mathbb{N}}_{\max, \gamma}}[[\gamma]]$  (see § 4.1). Then, according to Lem. 35,  $\mathcal{U}(e) = u$ . Hence,

$$\mathcal{H}(u) = (\mathcal{H}\mathcal{U})(e) = \psi(\mathcal{H}\mathcal{U})(e)$$

Therefore, if we are able to calculate the series  $\mathcal{H}\mathcal{U}$  in  $\mathcal{F}_{\overline{\mathbb{N}}_{\max, \gamma}}[[\gamma]]$ , the output induced by  $u$  is easily obtained.

A generalization of the previous discussion to the MIMO case is straightforward.



## 7.2. Operatorial Representation for $(\max, +)$ -linear Systems

In the following, the operatorial representation for  $(\max, +)$ -linear system is recalled. Let us consider the standard synchronization “for all  $k \geq l$ , occurrence  $k$  of event  $e_2$  is at least  $\tau$  units of time after occurrence  $k - l$  of event  $e_1$ ”. This corresponds to the following inequality in  $\overline{\mathbb{N}}_{\max}$ :

$$\forall k \in \mathbb{Z}, \quad e_2(k) \geq \tau e_1(k - l)$$

Rewriting this relation with the operators  $\gamma$  and  $\delta$  leads to  $e_2 \geq (\delta^\tau \gamma^l)(e_1)$ . Furthermore, the combinations of several standard synchronizations on the same event can be expressed by the operation  $\oplus$  over daters and operators. For example, standard synchronizations “for all  $k \geq l_1$ , occurrence  $k$  of event  $e_2$  is at least  $\tau_1$  units of time after occurrence  $k - l_1$  of event  $e_{1,1}$ ” and “for all  $k \geq l_2$ , occurrence  $k$  of event  $e_2$  is at least  $\tau_2$  units of time after occurrence  $k - l_2$  of event  $e_{1,2}$ ” are both expressed by a single inequality:

$$e_2 \geq (\delta^{\tau_1} \gamma^{l_1})(e_{1,1}) \oplus (\delta^{\tau_2} \gamma^{l_2})(e_{1,2})$$

Therefore, a  $(\max, +)$ -linear system admits an operatorial representation. Furthermore, as the entries of matrices  $\mathcal{A}$ ,  $\mathcal{B}$ , and  $\mathcal{C}$  belong to  $\mathcal{O}^{C,\gamma}$ , it is possible to obtain an operatorial representation in  $\mathcal{F}_{\overline{\mathbb{N}}_{\max,\gamma}}[\gamma]$ . An additional simplification is to rewrite this operatorial representation in  $\overline{\mathbb{N}}_{\max,\gamma}[\gamma]$ , as the entries of  $\mathcal{A}$ ,  $\mathcal{B}$ , and  $\mathcal{C}$  belong to  $\mathcal{F}_{\Delta,\gamma}[\gamma]$ . Hence, the fundamental theorem in  $\overline{\mathbb{N}}_{\max,\gamma}[\gamma]$  recalled in § 2.7.4 leads to important results concerning  $(\max, +)$ -linear systems. The transfer function matrix  $\mathcal{H}$  of a  $(\max, +)$ -linear system is given by  $\mathcal{C}\mathcal{A}^*\mathcal{B}$ . Matrices  $\mathcal{A}$ ,  $\mathcal{B}$ , and  $\mathcal{C}$  are rational. Then, according to Th. 6,  $\mathcal{A}^*$  is rational. Hence, the transfer function matrix  $\mathcal{H}$  is rational. Consequently, according to the fundamental theorem in  $\overline{\mathbb{N}}_{\max,\gamma}[\gamma]$ , the transfer function matrix  $\mathcal{H}$  is periodic. Conversely, let  $\mathcal{M}$  be a periodic matrix in  $\overline{\mathbb{N}}_{\max,\gamma}[\gamma]^{m \times p}$ . According to the fundamental theorem in  $\overline{\mathbb{N}}_{\max,\gamma}[\gamma]$ , matrix  $\mathcal{M}$  is realizable, *i.e.*, there exist  $n \in \mathbb{N}$ ,  $\mathcal{A} \in \{\varepsilon, e, 1, \gamma\}^{n \times n}$ ,  $\mathcal{B} \in \mathbb{B}^{n \times p}$ , and  $\mathcal{C} \in \mathbb{B}^{m \times n}$  such that  $\mathcal{M} = \mathcal{C}\mathcal{A}^*\mathcal{B}$ . Hence,  $\mathcal{M}$  corresponds to the transfer function matrix of the system described by the operatorial representation

$$\begin{cases} x \geq \mathcal{A}(x) \oplus \mathcal{B}(u) \\ y \geq \mathcal{C}(x) \end{cases}$$

This system is  $(\max, +)$ -linear as operators  $e$ ,  $\gamma$ , and  $1$  (*i.e.*,  $\delta$ ) respectively correspond to the following standard synchronizations:

- for all  $k \geq 0$ , occurrence  $k$  of event  $e_2$  is at least zero units of time after occurrence  $k$  of event  $e_1$
- for all  $k \geq 1$ , occurrence  $k$  of event  $e_2$  is at least zero units of time after occurrence  $k - 1$  of event  $e_1$

## 7. Operatorial Representation

- for all  $k \geq 0$ , occurrence  $k$  of event  $e_2$  is at least one unit of time after occurrence  $k$  of event  $e_1$

Furthermore, the results on calculation with periodic series in  $\overline{\mathbb{N}}_{\max, \gamma}[\gamma]$  and the software tools presented in § 2.7 are helpful to compute transfer function matrices and outputs induced by periodic inputs for  $(\max, +)$ -linear systems.

**Example 38.** To illustrate operatorial representation of  $(\max, +)$ -linear systems, let us consider the train line in Ex. 23 recalled in Fig. 7.2.

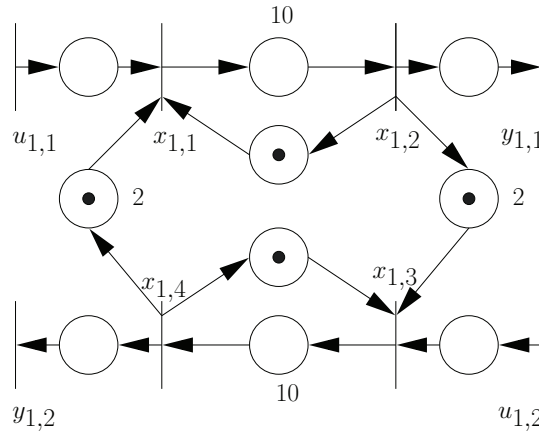

Figure 7.2.: Petri net representation of the train line

This system is a  $(\max, +)$ -linear system and its operatorial representation in  $\mathcal{O}^{C, \gamma}$  is

$$\left\{ \begin{array}{l} x_1 \geq \begin{pmatrix} \varepsilon & \gamma & \varepsilon & \delta^2 \gamma \\ \delta^{10} & \varepsilon & \varepsilon & \varepsilon \\ \varepsilon & \delta^2 \gamma & \varepsilon & \gamma \\ \varepsilon & \varepsilon & \delta^{10} & \varepsilon \end{pmatrix} (x_1) \oplus \begin{pmatrix} e & \varepsilon \\ \varepsilon & \varepsilon \\ \varepsilon & e \\ \varepsilon & \varepsilon \end{pmatrix} (u_1) \\ y_1 \geq \begin{pmatrix} \varepsilon & e & \varepsilon & \varepsilon \\ \varepsilon & \varepsilon & \varepsilon & e \end{pmatrix} (x_1) \end{array} \right.$$

Then, its operatorial representation in  $\mathcal{F}_{\overline{\mathbb{N}}_{\max, \gamma}}[\gamma]$  is

$$\left\{ \begin{array}{l} x_1 \geq \begin{pmatrix} \varepsilon & \gamma & \varepsilon & \Delta^2 \gamma \\ \Delta^{10} & \varepsilon & \varepsilon & \varepsilon \\ \varepsilon & \Delta^2 \gamma & \varepsilon & \gamma \\ \varepsilon & \varepsilon & \Delta^{10} & \varepsilon \end{pmatrix} (x_1) \oplus \begin{pmatrix} e & \varepsilon \\ \varepsilon & \varepsilon \\ \varepsilon & e \\ \varepsilon & \varepsilon \end{pmatrix} (u_1) \\ y_1 \geq \begin{pmatrix} \varepsilon & e & \varepsilon & \varepsilon \\ \varepsilon & \varepsilon & \varepsilon & e \end{pmatrix} (x_1) \end{array} \right.$$

Finally, its operatorial representation in  $\overline{\mathbb{N}}_{\max, \gamma}[[\gamma]]$  is

$$\left\{ \begin{array}{l} x_1 \geq \begin{pmatrix} \varepsilon & \gamma & \varepsilon & 2\gamma \\ 10 & \varepsilon & \varepsilon & \varepsilon \\ \varepsilon & 2\gamma & \varepsilon & \gamma \\ \varepsilon & \varepsilon & 10 & \varepsilon \end{pmatrix} (x_1) \oplus \begin{pmatrix} e & \varepsilon \\ \varepsilon & \varepsilon \\ \varepsilon & e \\ \varepsilon & \varepsilon \end{pmatrix} (u_1) \\ y_1 \geq \begin{pmatrix} \varepsilon & e & \varepsilon & \varepsilon \\ \varepsilon & \varepsilon & \varepsilon & e \end{pmatrix} (x_1) \end{array} \right.$$

The transfer function matrix of the considered  $(\max, +)$ -linear system, denoted  $\mathcal{H}_1$ , is given by

$$\mathcal{H}_1 = \begin{pmatrix} (10 \oplus 20\gamma) (24\gamma^2)^* & (22\gamma \oplus 32\gamma^2) (24\gamma^2)^* \\ (22\gamma \oplus 32\gamma^2) (24\gamma^2)^* & (10 \oplus 20\gamma) (24\gamma^2)^* \end{pmatrix}$$

As expected, the transfer function matrix  $\mathcal{H}_1$  is periodic. Let us consider the particular input  $u_1$  defined by  $u_{1,1} = u_{1,2} = e \oplus 20\gamma^2 (15\gamma)^*$ . The output  $y_1$  induced by input  $u_1$  is given by

$$y_1 = \mathcal{H}_1 (u_1) = \mathcal{H}_1 \otimes u_1 = \begin{pmatrix} 10 \oplus 22\gamma \oplus 34\gamma^2 \oplus 46\gamma^3 \oplus 60\gamma^4 (15\gamma)^* \\ 10 \oplus 22\gamma \oplus 34\gamma^2 \oplus 46\gamma^3 \oplus 60\gamma^4 (15\gamma)^* \end{pmatrix}$$

Note that the notation is slightly ambiguous, as  $\mathcal{H}_1$  corresponds both to the transfer function matrix (i.e., a matrix of operators) and to a matrix of impulse responses (i.e., a matrix of daters).

### 7.3. Operatorial Representation for $(\max, +)$ -systems Subject to Partial Synchronization

In the following, the operatorial representation for  $(\max, +)$ -systems subject to partial synchronization is introduced. As for  $(\max, +)$ -linear systems, standard synchronizations are modeled using the operators  $\gamma$  and  $\delta$ . The main difficulty is to represent partial synchronizations by operators. This problem is solved by using the  $\alpha$ -mappings introduced in § 3.5. As a reminder, the  $\alpha$ -mapping associated with a dater  $d$ , denoted  $\alpha_d$ , is a mapping in  $\mathcal{F}_{\overline{\mathbb{N}}_{\max}}$  defined by

$$\forall x \in \overline{\mathbb{N}}_{\max}, \quad \alpha_d (x) = \bigwedge \{z \geq x \mid z \in \text{Im}(d) \cup \{T\}\}$$

Let  $x$  be an event and  $d$  be a predetermined dater.

event  $x$  is subject to a partial synchronization by dater  $d$

$$\begin{aligned} &\Leftrightarrow \forall k \in \mathbb{Z}, \quad x(k) \in \text{Im}(d) \cup \{\top\} \\ &\Leftrightarrow \forall k \in \mathbb{Z}, \quad x(k) = \alpha_d(x(k)) \\ &\Leftrightarrow \forall k \in \mathbb{Z}, \quad x(k) \geq \alpha_d(x(k)) \text{ as } \alpha_d \geq \text{Id} \\ &\Leftrightarrow x \geq \alpha_d \circ x \\ &\Leftrightarrow x \geq L_{\alpha_d}(x) \text{ as } \alpha_d \in \mathcal{F}_{\overline{\mathbb{N}}_{\max}} \end{aligned}$$

Therefore, partial synchronizations are modeled by composition operators based on  $\alpha$ -mappings. As before, a combination of several (standard and/or partial) synchronizations affecting the same event boils down to a single inequality by using the operations  $\oplus$  over daters and operators. This leads to an operatorial representation in  $\mathcal{O}^{C,\gamma}$  for  $(\max, +)$ -systems subject to partial synchronization. As shown in Prop. 40, this operatorial representation can be written in  $\mathcal{F}_{\overline{\mathbb{N}}_{\max},\gamma}[\![\gamma]\!]$ .

**Example 39.** The operatorial representation in  $\mathcal{O}^{C,\gamma}$  associated with Ex. 35 is

$$\left\{ \begin{array}{l} x \geq \begin{pmatrix} \varepsilon & \gamma^3 & \varepsilon \\ \delta^{10} & L_{\alpha_d} \oplus \delta\gamma & \gamma^3 \\ \varepsilon & \delta^{10} & L_{\alpha_d} \oplus \delta\gamma \end{pmatrix} (x) \oplus \begin{pmatrix} e \\ \varepsilon \\ \varepsilon \end{pmatrix} (u) \\ y \geq \begin{pmatrix} \varepsilon & \varepsilon & e \end{pmatrix} (x) \end{array} \right.$$

In  $\mathcal{F}_{\overline{\mathbb{N}}_{\max},\gamma}[\![\gamma]\!]$ , the operatorial representation becomes

$$\left\{ \begin{array}{l} x \geq \begin{pmatrix} \varepsilon & \gamma^3 & \varepsilon \\ \Delta^{10} & \alpha_d \oplus \Delta\gamma & \gamma^3 \\ \varepsilon & \Delta^{10} & \alpha_d \oplus \Delta\gamma \end{pmatrix} (x) \oplus \begin{pmatrix} e \\ \varepsilon \\ \varepsilon \end{pmatrix} (u) \\ y \geq \begin{pmatrix} \varepsilon & \varepsilon & e \end{pmatrix} (x) \end{array} \right.$$

The dater  $d$  represents the behavior of the traffic lights and is known.

### 7.3.1. Periodic Case

In the following, only the particular case where the predefined daters in partial synchronizations are periodic is considered. Then, according to Prop. 23, the  $\alpha$ -mappings associated with partial synchronizations are periodic. Hence, the entries of  $\mathcal{A}$ ,  $\mathcal{B}$ , and  $\mathcal{C}$  are causal periodic series in  $\mathcal{F}_{\overline{\mathbb{N}}_{\max},\gamma}[\![\gamma]\!]$ . This leads to an interpretation in terms of system theory for the fundamental theorem in  $\mathcal{F}_{\overline{\mathbb{N}}_{\max},\gamma}[\![\gamma]\!]$  introduced in § 4.6. The transfer function matrix

of the system is  $\mathcal{H} = \mathcal{C}\mathcal{A}^*\mathcal{B}$ . Matrices  $\mathcal{A}$ ,  $\mathcal{B}$ , and  $\mathcal{C}$  are rational. Then, according to Th. 6,  $\mathcal{A}^*$  is rational. Hence, the transfer function matrix  $\mathcal{H}$  is rational. Consequently, according to the fundamental theorem in  $\mathcal{F}_{\overline{\mathbb{N}}_{\max, \gamma}}[[\gamma]]$ , the transfer function matrix  $\mathcal{H}$  is causal and periodic. Conversely, let  $\mathcal{M}$  be a causal and periodic matrix in  $\mathcal{F}_{\overline{\mathbb{N}}_{\max, \gamma}}[[\gamma]]^{m \times p}$ . According to the fundamental theorem in  $\mathcal{F}_{\overline{\mathbb{N}}_{\max, \gamma}}[[\gamma]]$ , matrix  $\mathcal{M}$  is realizable. Hence, there exists a finite number  $N$  of periodic series  $r_1, \dots, r_N$  in  $\overline{\mathbb{N}}_{\max, \gamma}[[\gamma]]$  such that  $S$  admits a  $(B, C)$ -representation with respect to  $\{\varepsilon, e, \Delta, \alpha_{r_1}, \dots, \alpha_{r_N}, \gamma\}$  where all non-diagonal entries of  $A$  belong to  $\{\varepsilon, e, \Delta, \gamma\}$ . Therefore,  $\mathcal{M}$  corresponds to the transfer function matrix of the system described by the operatorial representation

$$\begin{cases} x \geq \mathcal{A}(x) \oplus \mathcal{B}(u) \\ y \geq \mathcal{C}(x) \end{cases}$$

This system is a  $(\max, +)$ -system subject to partial synchronization. Indeed, entries of  $\mathcal{A}$ ,  $\mathcal{B}$ , and  $\mathcal{C}$  equal to operators  $e$ ,  $\gamma$ , or  $\Delta$  (i.e.,  $\delta$ ) respectively correspond to the following standard synchronizations:

- for all  $k \geq 0$ , occurrence  $k$  of event  $e_2$  is at least zero units of time after occurrence  $k$  of event  $e_1$
- for all  $k \geq 1$ , occurrence  $k$  of event  $e_2$  is at least zero units of time after occurrence  $k - 1$  of event  $e_1$
- for all  $k \geq 0$ , occurrence  $k$  of event  $e_2$  is at least one unit of time after occurrence  $k$  of event  $e_1$

Furthermore, the entries of  $\mathcal{A}$  corresponding to a  $\alpha$ -mapping are diagonal and correspond to partial synchronization of the event by a predefined periodic dater. This interpretation makes clear the necessity of forcing the  $\alpha$ -mappings to be on the diagonal of matrix  $\mathcal{A}$  in the definition of realizability.

Moreover, the results on calculation with periodic series in  $\mathcal{F}_{\overline{\mathbb{N}}_{\max, \gamma}}[[\gamma]]$  introduced in § 4 are helpful to compute transfer function matrices and outputs induced by periodic inputs for  $(\max, +)$ -systems subject to partial synchronization. In the following, several examples are discussed.

**Example 40.** *The transfer function of the  $(\max, +)$ -system subject to partial synchronization introduced in Ex. 35 (i.e., a one-way road equipped with two traffic lights) is given by*

$$\mathcal{H} = \left( \Delta^{12} \gamma^3 \right)^* \left( f_1 \oplus f_2 \gamma \oplus f_3 \gamma^2 \right)$$

where

$$f_1(x) = \begin{cases} x & \text{if } x \in \{\varepsilon, \top\} \\ 24 \otimes 6^k & \text{if } 6^k \leq x < 5 \otimes 6^k \text{ with } k \in \mathbb{N}_0 \\ 30 \otimes 6^k & \text{if } x = 5 \otimes 6^k \text{ with } k \in \mathbb{N}_0 \end{cases}$$

$$f_2(x) = \begin{cases} x & \text{if } x \in \{\varepsilon, \top\} \\ 25 \otimes 6^k & \text{if } 6^k \leq x < 4 \otimes 6^k \text{ with } k \in \mathbb{N}_0 \\ 30 \otimes 6^k & \text{if } x = 4 \otimes 6^k \text{ with } k \in \mathbb{N}_0 \\ 31 \otimes 6^k & \text{if } x = 5 \otimes 6^k \text{ with } k \in \mathbb{N}_0 \end{cases}$$

$$f_3(x) = \begin{cases} x & \text{if } x \in \{\varepsilon, \top\} \\ 26 \otimes 6^k & \text{if } 6^k \leq x < 3 \otimes 6^k \text{ with } k \in \mathbb{N}_0 \\ 30 \otimes 6^k & \text{if } x = 3 \otimes 6^k \text{ with } k \in \mathbb{N}_0 \\ 31 \otimes 6^k & \text{if } x = 4 \otimes 6^k \text{ with } k \in \mathbb{N}_0 \\ 32 \otimes 6^k & \text{if } x = 5 \otimes 6^k \text{ with } k \in \mathbb{N}_0 \end{cases}$$

As expected, the transfer function  $\mathcal{H}$  is causal and periodic. A graphical representation of the transfer function  $\mathcal{H}$  is drawn in Fig. 7.3. The transfer function leads directly to the impulse response of the system (i.e., the output induced by an infinity of vehicles arriving at  $t = 0$ ).

$$\mathcal{H}(e) = \psi(\mathcal{H})(e) = (24 \oplus 25\gamma \oplus 26\gamma^2) (12\gamma^3)^*$$

Let us consider the periodic input  $u$  equal to  $e \oplus \gamma^3 (6\gamma)^*$ . This input models the arrival of four vehicles at  $t = 0$  and of one vehicle at  $t = 6k$  with  $k \in \mathbb{N}$ . In  $\mathcal{F}_{\Delta, \gamma}[\llbracket \gamma \rrbracket]$ , input  $u$  corresponds to the series  $\mathcal{U}$  defined by

$$\mathcal{U} = e \oplus (\Delta^6 \gamma)^* \gamma^3$$

Then,

$$\begin{aligned} \mathcal{H}\mathcal{U} &= f_1 \oplus f_2\gamma \oplus f_3\gamma^2 \oplus \Delta^{12}f_1\gamma^3 \oplus \Delta^{12}f_2\gamma^4 \oplus \Delta^{12}f_3\gamma^5 \oplus \Delta^{24}f_1\gamma^6 \\ &\quad \oplus \Delta^{24}f_2\gamma^7 \oplus (\Delta^{24}f_3 \oplus \Delta^{30}f_1) \gamma^8 \oplus (\Delta^6 \gamma)^* \Delta^{36}f_1\gamma^9 \end{aligned}$$

Hence, the output induced by  $u$  is given by

$$\begin{aligned} \mathcal{H}(u) &= \mathcal{H}\mathcal{U}(e) \\ &= \psi(\mathcal{H}\mathcal{U})(e) \\ &= 24 \oplus 25\gamma \oplus 26\gamma^2 \oplus 36\gamma^3 \oplus 37\gamma^4 \oplus 38\gamma^5 \oplus 48\gamma^6 \oplus 49\gamma^7 \oplus 54\gamma^8 (6\gamma)^* \end{aligned}$$

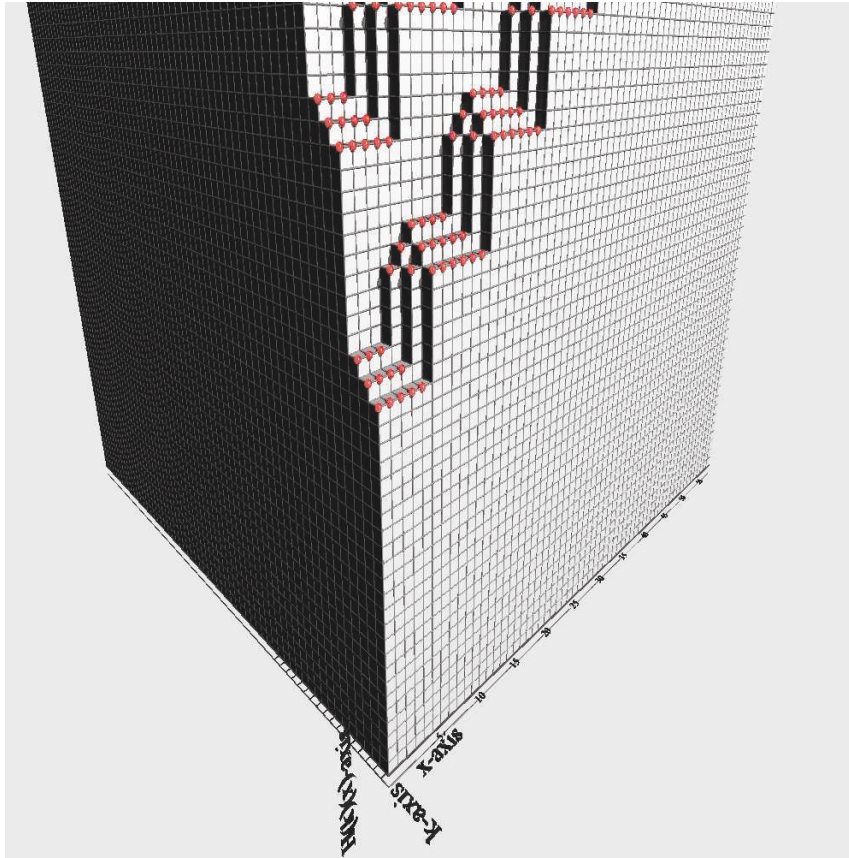

Figure 7.3.: Transfer function of the road equipped with traffic lights

**Example 41.** In this example, operatorial representation in  $\mathcal{F}_{\mathbb{N}_{\max}, \gamma}[\gamma]$  is used to calculate outputs induced by periodic inputs for  $(\max, +)$ -systems with partial synchronization. We consider the  $(\max, +)$ -system with partial synchronization presented in Ex. 23 (i.e., the supply chain). The periodic input is defined by

$$\begin{aligned} u_{1,1} &= u_{1,2} = e \oplus 20\gamma^2 (15\gamma)^* \\ u_{2,1} &= u_{2,2} = (90\gamma)^* \end{aligned}$$

The main system is a  $(\max, +)$ -linear system and the output  $y_1$  induced by input  $u_1$  has already been computed in Ex. 38. Furthermore, this input leads to the following daters for the

state events in the main system.

$$x_1 = \begin{pmatrix} e \oplus 12\gamma \oplus 24\gamma^2 \oplus 36\gamma^3 \oplus 50\gamma^4 (15\gamma)^* \\ 10 \oplus 22\gamma \oplus 34\gamma^2 \oplus 46\gamma^3 \oplus 60\gamma^4 (15\gamma)^* \\ e \oplus 12\gamma \oplus 24\gamma^2 \oplus 36\gamma^3 \oplus 50\gamma^4 (15\gamma)^* \\ 10 \oplus 22\gamma \oplus 34\gamma^2 \oplus 46\gamma^3 \oplus 60\gamma^4 (15\gamma)^* \end{pmatrix}$$

Hence, under this behavior of the main system, the secondary system corresponds to a  $(\max, +)$ -system subject to partial synchronization. The transfer function matrix, denoted  $\mathcal{H}_2$ , of this  $(\max, +)$ -system subject to partial synchronization is given by

$$\mathcal{H}_2 = \begin{pmatrix} f_{11} \oplus (\Delta^{60}\gamma)^* f_{1\gamma} & f_{12}\gamma \oplus (\Delta^{60}\gamma)^* \Delta^{30}f_{2\gamma^2} \\ f_{21} \oplus (\Delta^{60}\gamma)^* \Delta^{30}f_{1\gamma} & f_{22} \oplus (\Delta^{60}\gamma)^* f_{2\gamma} \end{pmatrix}$$

where

$$f_{11}(x) = \begin{cases} x & \text{if } x \in \{\varepsilon, \top\} \\ 27 & \text{if } e \leq x < 8 \\ 39 & \text{if } 8 \leq x < 20 \\ 51 & \text{if } 20 \leq x < 32 \\ 65 & \text{if } 32 \leq x < 46 \\ 80 \otimes 15^k & \text{if } 46 \otimes 15^k \leq x < 61 \otimes 15^k \text{ with } k \in \mathbb{N}_0 \end{cases}$$

$$f_{12}(x) = \begin{cases} x & \text{if } x \in \{\varepsilon, \top\} \\ 39 & \text{if } x = e \\ 51 & \text{if } 1 \leq x < 13 \\ 65 & \text{if } 13 \leq x < 25 \\ 80 & \text{if } 25 \leq x < 37 \\ 95 & \text{if } 37 \leq x < 51 \\ 110 \otimes 15^k & \text{if } 51 \otimes 15^k \leq x < 66 \otimes 15^k \text{ with } k \in \mathbb{N}_0 \end{cases}$$

$$f_{21}(x) = \begin{cases} x & \text{if } x \in \{\varepsilon, \top\} \\ 51 & \text{if } e \leq x < 8 \\ 65 & \text{if } 8 \leq x < 20 \\ 80 & \text{if } 20 \leq x < 32 \\ 95 & \text{if } 32 \leq x < 46 \\ 110 \otimes 15^k & \text{if } 46 \otimes 15^k \leq x < 61 \otimes 15^k \text{ with } k \in \mathbb{N}_0 \end{cases}$$



$$f_{22}(x) = \begin{cases} x & \text{if } x \in \{\varepsilon, \top\} \\ 15 & \text{if } x = e \\ 27 & \text{if } 1 \leq x < 13 \\ 39 & \text{if } 13 \leq x < 25 \\ 51 & \text{if } 25 \leq x < 37 \\ 65 & \text{if } 37 \leq x < 51 \\ 80 \otimes 15^k & \text{if } 51 \otimes 15^k \leq x < 66 \otimes 15^k \text{ with } k \in \mathbb{N}_0 \end{cases}$$

$$f_1(x) = \begin{cases} x & \text{if } x \in \{\varepsilon, \top\} \\ 80 & \text{if } e \leq x < 8 \\ 95 & \text{if } 8 \leq x < 20 \\ 110 & \text{if } 20 \leq x < 32 \\ 125 & \text{if } 32 \leq x < 46 \\ 140 \otimes 15^k & \text{if } 46 \otimes 15^k \leq x < 61 \otimes 15^k \text{ with } k \in \mathbb{N}_0 \end{cases}$$

$$f_2(x) = \begin{cases} x & \text{if } x \in \{\varepsilon, \top\} \\ 65 & \text{if } x = e \\ 80 & \text{if } 1 \leq x < 13 \\ 95 & \text{if } 13 \leq x < 25 \\ 110 & \text{if } 25 \leq x < 37 \\ 125 & \text{if } 37 \leq x < 51 \\ 140 \otimes 15^k & \text{if } 51 \otimes 15^k \leq x < 66 \otimes 15^k \text{ with } k \in \mathbb{N}_0 \end{cases}$$

The impulse response of this  $(\max, +)$ -system subject to partial synchronization is given by

$$\begin{aligned} \mathcal{H}_2(e) &= \begin{pmatrix} \psi(\mathcal{H}_{2,11})(e) \oplus \psi(\mathcal{H}_{2,12})(e) \\ \psi(\mathcal{H}_{2,21})(e) \oplus \psi(\mathcal{H}_{2,22})(e) \end{pmatrix} \\ &= \begin{pmatrix} 27 \oplus 80\gamma(60\gamma)^* \\ 51 \oplus 110\gamma(60\gamma)^* \end{pmatrix} \end{aligned}$$

Next, we compute the response of this  $(\max, +)$ -system subject to partial synchronization to the input  $u_2$ . The matrix with entries in  $\mathcal{F}_{\Delta, \gamma}[\gamma]$  associated with  $u_2$ , denoted  $\mathcal{U}_2$ , is given by

$$\mathcal{U}_2 = \begin{pmatrix} (\Delta^{90}\gamma)^* \\ (\Delta^{90}\gamma)^* \end{pmatrix}$$

Then,

$$\mathcal{H}_2\mathcal{U}_2 = \begin{pmatrix} f_{11} \oplus (\Delta^{90}\gamma)^* f_{11}\Delta^{90}\gamma \\ f_{21} \oplus (\Delta^{90}\gamma)^* f_{21}\Delta^{90}\gamma \end{pmatrix}$$

Hence,

$$\begin{aligned} \mathcal{H}_2(u_2) &= \mathcal{H}_2 \mathcal{U}_2(e) \\ &= \begin{pmatrix} \psi((\mathcal{H}_2 \mathcal{U}_2)_1)(e) \\ \psi((\mathcal{H}_2 \mathcal{U}_2)_2)(e) \end{pmatrix} \\ &= \begin{pmatrix} 27 \oplus 110\gamma(90\gamma)^* \\ 51 \oplus 140\gamma(90\gamma)^* \end{pmatrix} \end{aligned}$$

**Example 42.** In the previous examples, transfer function matrices have entries in the dioid  $\mathcal{F}_{\mathbb{N}_{\max, \gamma}}^{\text{per}, c}[\gamma]$ . In terms of system theory, this means that the throughput of an impulse response does not depend on the occurring time  $t \in \mathbb{N}_0$  of the impulse. In the following, we present a  $(\max, +)$ -system subject to partial synchronization where the throughput of an impulse response depends on the occurring time  $t \in \mathbb{N}_0$  of the impulse. Let us consider the  $(\max, +)$ -system subject to partial synchronization drawn in Fig. 7.4.

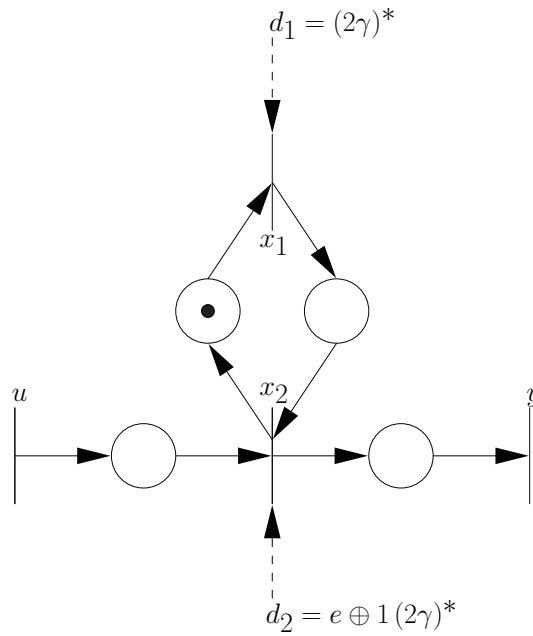

Figure 7.4.: Petri net representation of a  $(\max, +)$ -system subject to partial synchronization exhibiting impulse responses with different throughputs

The corresponding operatorial representation in  $\mathcal{F}_{\mathbb{N}_{\max}, \gamma}[\gamma]$  is

$$\begin{cases} x \geq \begin{pmatrix} \alpha_{d_1} & \gamma \\ e & \alpha_{d_2} \end{pmatrix} (x) \oplus \begin{pmatrix} \varepsilon \\ e \end{pmatrix} (u) \\ y \geq \begin{pmatrix} \varepsilon & e \end{pmatrix} (x) \end{cases}$$

This leads to the transfer function  $\mathcal{H}$  defined by

$$\mathcal{H} = e \oplus (\Delta^2 \gamma)^* f \text{ with } f(x) = \begin{cases} \varepsilon & \text{if } x < 1 \\ 1 & \text{if } x = 1 \\ 1 \otimes 2^k & \text{if } 2^k \leq x < 2^{k+1} \text{ with } k \in \mathbb{N} \\ \top & \text{if } x = \top \end{cases}$$

A graphical representation of  $\mathcal{H}$  is drawn in Fig. 7.5. For an impulse occurring at  $t = 0$ ,

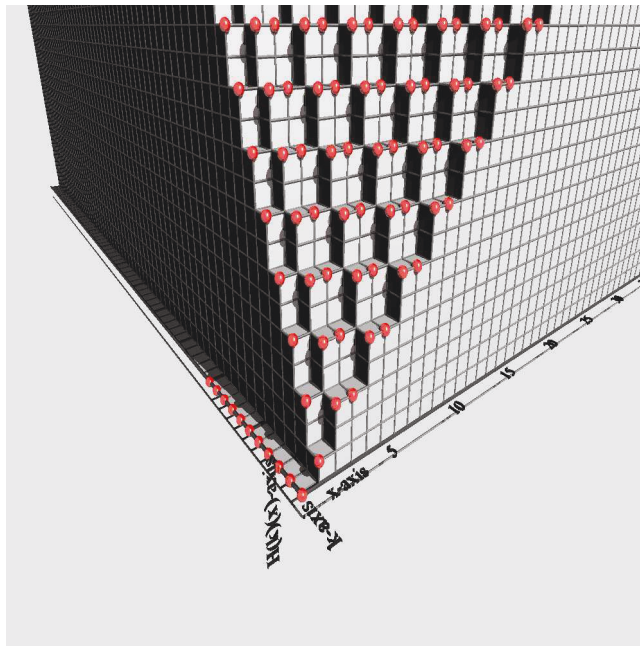

Figure 7.5.: Transfer function  $\mathcal{H} = e \oplus (\Delta^2 \gamma)^* f$

the throughput of the induced output is  $+\infty$ , while, for an impulse occurring at  $t \in \mathbb{N}$ , the throughput of the induced output is 2.



## Model Reference Control

---

In this chapter, model reference control for  $(\max, +)$ -systems with partial synchronization is discussed. A model reference representing a required transfer function matrix is given. The aim of this approach is to modify the transfer function matrix of the system to match as closely as possible the model reference. A prerequisite for this approach is the existence of transfer function matrices. Hence, model reference control cannot be applied to  $(\max, +)$ -systems with partial synchronization. However, it makes sense for  $(\max, +)$ -linear systems and  $(\max, +)$ -systems subject to partial synchronization, as transfer function matrices are provided by the operatorial representations in  $\overline{\mathbb{N}}_{\max, \gamma}[\gamma]$  and in  $\mathcal{F}_{\overline{\mathbb{N}}_{\max, \gamma}}[\gamma]$ . For  $(\max, +)$ -linear systems, model reference control has been widely investigated [12, 14, 25, 30]. In the following, we investigate how to extend these results to  $(\max, +)$ -systems subject to partial synchronization. We mainly focus on adding prefilters and feedbacks to modify the transfer function matrix of the system. However, more sophisticated control structures already developed for  $(\max, +)$ -linear systems could be adapted to  $(\max, +)$ -systems subject to partial synchronization in the same way.

The fundamental difference between optimal control and model reference control is that optimal control acts by applying a particular input while model reference control modifies the dynamics of the system. Hence, model reference control does not contain any requirement on the input. In many applications, the input is not a degree of freedom, but depends on external factors. In Ex. 35, the arrival of vehicles (*i.e.*, the input) is not a degree of freedom, but depends on the overall traffic. Therefore, optimal control is not suitable for this case, but model reference control leads to interesting results presented in the following.

### 8.1. Prefilter

Let us consider a  $(\max, +)$ -system subject to partial synchronization with a transfer function matrix  $\mathcal{H}$  in  $\mathcal{F}_{\overline{\mathbb{N}}_{\max}, \gamma}[\gamma]^{p \times m}$ . A prefilter  $\mathcal{P}$  in  $\mathcal{F}_{\overline{\mathbb{N}}_{\max}, \gamma}[\gamma]^{m \times m}$  is added ahead of the system. The model reference is specified by the matrix  $\mathcal{G}$  in  $\mathcal{F}_{\overline{\mathbb{N}}_{\max}, \gamma}[\gamma]^{p \times m}$ . The problem formulation is summarized in Fig. 8.1.

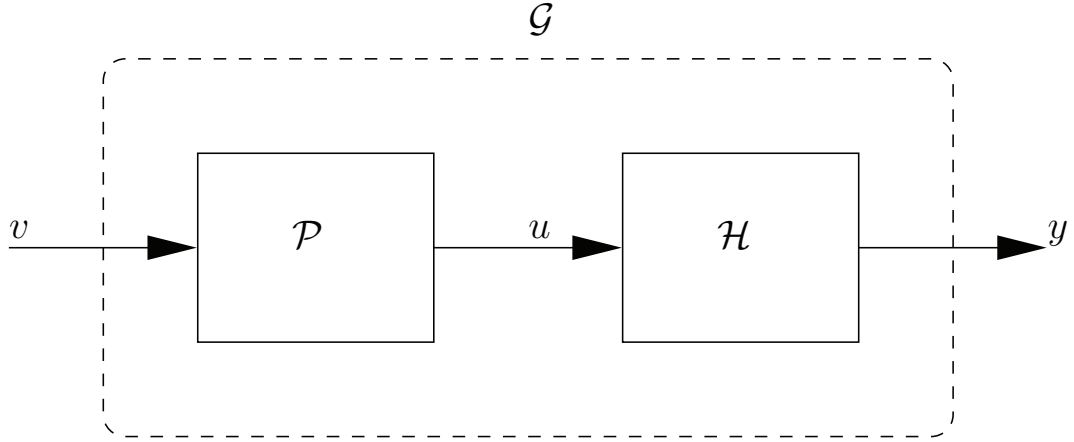

Figure 8.1.: Model reference control with prefilter

The transfer function matrix of the overall system is  $\mathcal{H}\mathcal{P}$ . Indeed,

$$y = \mathcal{H}(u) = \mathcal{H}(\mathcal{P}(v)) = \mathcal{H}\mathcal{P}(v)$$

The aim of model reference control is to match as closely as possible the model reference  $\mathcal{G}$ . This is formalized by finding the greatest solution  $\mathcal{P}$  of  $\mathcal{H}\mathcal{P} \leq \mathcal{G}$ . Then,  $\mathcal{G}$  represents a least upper bound for the admissible behavior of the overall system. Furthermore, taking the greatest solution maximizes the input  $u = \mathcal{P}(v)$  of the original system (*i.e.*, delays as much as possible the occurrences of input events). As the dioid  $\mathcal{F}_{\overline{\mathbb{N}}_{\max}, \gamma}[\gamma]$  is complete, the greatest solution, denoted  $\mathcal{P}_{\max}$ , of  $\mathcal{H}\mathcal{P} \leq \mathcal{G}$  is given by

$$\mathcal{P}_{\max} = \mathcal{H} \setminus \mathcal{G}$$

The previous reasoning is not constructive and does not lead to a practical implementation of  $\mathcal{P}_{\max}$ . In practice, the prefilter can only use information from the past to compute occurrences of input events. Hence, the prefilter  $\mathcal{P}$  is required to be causal. Hence,

$$\mathcal{P}_{\max} = \text{Pr}_{++}(\mathcal{P}_{\max}) = \mathcal{H} \setminus_{++} \mathcal{G}$$

Furthermore, if  $\mathcal{H}$  and  $\mathcal{G}$  are causal periodic matrices (for  $\mathcal{H}$ , this means considering periodic synchronizing daters), Prop. 26 and Prop. 31 give an algorithm to compute  $\mathcal{P}_{\max}$  and ensure

that  $\mathcal{P}_{\max}$  is periodic. Thus, according to the fundamental theorem in  $\mathcal{F}_{\overline{\mathbb{N}}_{\max}, \gamma}[\gamma]$ ,  $\mathcal{P}_{\max}$  is realizable (i.e.,  $\mathcal{P}_{\max}$  can be seen as the transfer function matrix of a  $(\max, +)$ -system subject to partial synchronization). This leads to a practical implementation of  $\mathcal{P}_{\max}$ .

**Remark 24** (Neutral prefilter). *An interesting particular case is choosing  $\mathcal{G} = \mathcal{H}$ . Then,  $\mathcal{P}_{\max} = \mathcal{H} \downarrow_{++} \mathcal{H}$ . In the literature, this prefilter is called neutral prefilter as it does not modify the transfer function matrix of the system, i.e.,  $\mathcal{H}\mathcal{P}_{\max} = \mathcal{H}$ .*

**Example 43.** *In the following, the neutral prefilter, denoted  $\mathcal{P}_{\max}$ , for the  $(\max, +)$ -system subject to partial synchronization introduced in Ex. 35 (i.e., a one-way road equipped with two traffic lights) is computed. The transfer function  $\mathcal{H}$  of this system has already been computed in Ex. 40. Hence,*

$$\mathcal{P}_{\max} = \mathcal{H} \downarrow_{++} \mathcal{H} = \left( \Delta^{12} \gamma^3 \right)^* \left( p_1 \oplus p_2 \gamma \oplus p_3 \gamma^2 \right)$$

with

$$p_1(x) = \begin{cases} x & \text{if } x \in \{\varepsilon, \top\} \\ 2 \otimes 6^k & \text{if } 6^k \leq x < 3 \otimes 6^k \text{ with } k \in \mathbb{N}_0 \\ 3 \otimes 6^k & \text{if } x = 3 \otimes 6^k \text{ with } k \in \mathbb{N}_0 \\ 4 \otimes 6^k & \text{if } x = 4 \otimes 6^k \text{ with } k \in \mathbb{N}_0 \\ 8 \otimes 6^k & \text{if } x = 5 \otimes 6^k \text{ with } k \in \mathbb{N}_0 \end{cases}$$

$$p_2(x) = \begin{cases} x & \text{if } x \in \{\varepsilon, \top\} \\ 3 \otimes 6^k & \text{if } 6^k \leq x < 3 \otimes 6^k \text{ with } k \in \mathbb{N}_0 \\ 4 \otimes 6^k & \text{if } x = 3 \otimes 6^k \text{ with } k \in \mathbb{N}_0 \\ 9 \otimes 6^k & \text{if } 4 \otimes 6^k \leq x < 6^{k+1} \text{ with } k \in \mathbb{N}_0 \end{cases}$$

$$p_3(x) = \begin{cases} x & \text{if } x \in \{\varepsilon, \top\} \\ 4 \otimes 6^k & \text{if } 6^k \leq x < 3 \otimes 6^k \text{ with } k \in \mathbb{N}_0 \\ 10 \otimes 6^k & \text{if } 3 \otimes 6^k \leq x < 6^{k+1} \text{ with } k \in \mathbb{N}_0 \end{cases}$$

A graphical representation of the neutral prefilter  $\mathcal{P}_{\max}$  is drawn in Fig. 8.2. Furthermore, a realization of  $\mathcal{P}_{\max}$  as  $(\max, +)$ -system subject to partial synchronization is provided in Fig. 8.3.

**Example 44.** *In the following, the neutral prefilter, denoted  $\mathcal{P}_{\max}$ , for the  $(\max, +)$ -system subject to partial synchronization introduced in Ex. 42 is computed. Note that the considered transfer function  $\mathcal{H}$  fulfills  $\mathcal{H} = \mathcal{H}^*$ . Hence, finding the neutral prefilter  $\mathcal{P}_{\max}$  is equivalent to finding the greatest causal solution of  $\mathcal{H}^* \mathcal{P} \leq \mathcal{H}^*$ . Consequently,  $\mathcal{P}_{\max} = \mathcal{H}^* = \mathcal{H}$ .*

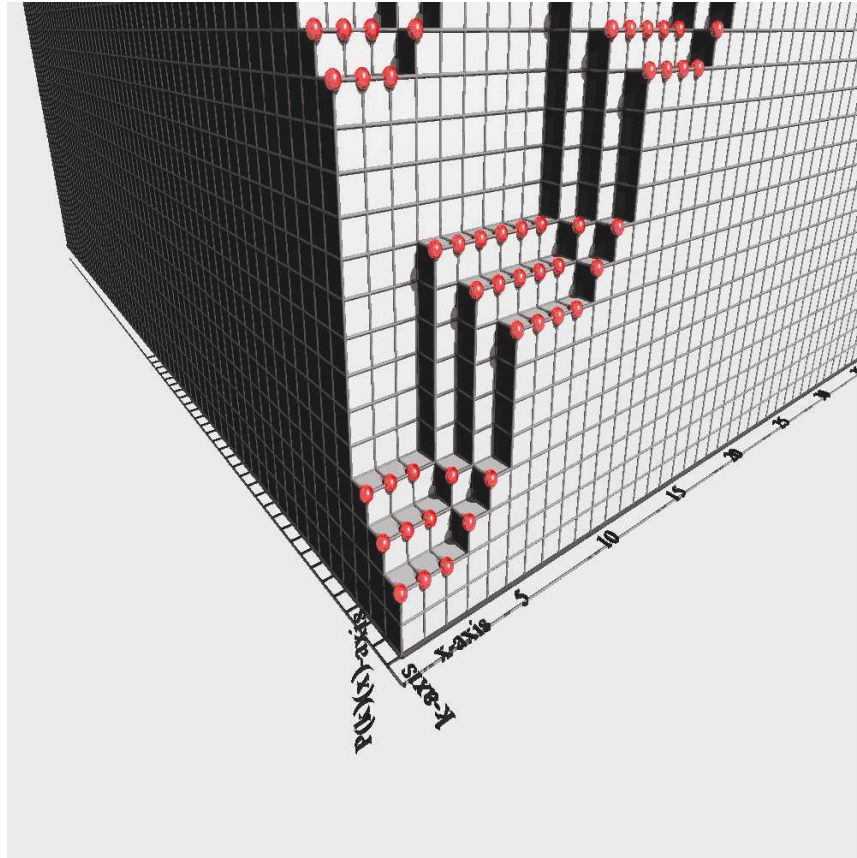

Figure 8.2.: Neutral prefilter for the road equipped with traffic lights

## 8.2. Feedback

Let us consider a  $(\max, +)$ -system subject to partial synchronization with a transfer function matrix  $\mathcal{H}$  in  $\mathcal{F}_{\bar{N}_{\max, \gamma}}[\gamma]^{p \times m}$ . An output feedback  $\mathcal{F}$  in  $\mathcal{F}_{\bar{N}_{\max, \gamma}}[\gamma]^{m \times p}$  is added. The model reference is specified by the matrix  $\mathcal{G}$  in  $\mathcal{F}_{\bar{N}_{\max, \gamma}}[\gamma]^{p \times m}$ . The problem formulation is summarized in Fig. 8.4.

As  $y = \mathcal{H}(u)$  and  $u = \mathcal{F}(y) \oplus v$ , output  $y$  corresponds to the least solution of

$$y = \mathcal{H}\mathcal{F}(y) \oplus \mathcal{H}(v)$$

Hence, the transfer function matrix of the overall system is  $(\mathcal{H}\mathcal{F})^* \mathcal{H}$ .

The aim of model reference control is to match as closely as possible the model reference  $\mathcal{G}$ . This is formalized by finding the greatest solution  $\mathcal{F}$  of  $(\mathcal{H}\mathcal{F})^* \mathcal{H} \leq \mathcal{G}$ . Then,  $\mathcal{G}$  represents a least upper bound for the admissible behavior of the overall system. Furthermore,



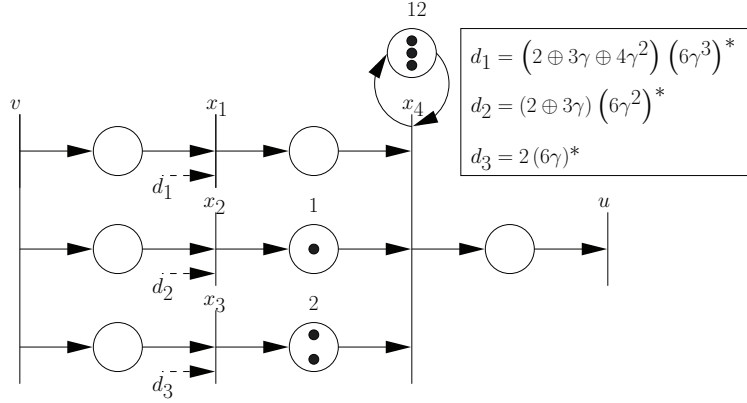

Figure 8.3.: Realization of the neutral prefilter for the road equipped with traffic lights

taking the greatest solution maximizes the input  $u = \mathcal{F}(y) \oplus v$  of the original system (*i.e.*, delays as much as possible the occurrences of input events). Obviously, this problem may have no solution, *e.g.*, if  $\mathcal{G}$  is not greater than or equal to  $\mathcal{H}$ . Using the reasoning developed in [14], this problem is solved for the class of model reference  $\mathcal{G}$  defined by

$$\mathcal{G} = \left\{ \mathcal{G} \in \mathcal{F}_{\bar{\mathbb{N}}_{\max}, \gamma}^{\text{per}, c}[\gamma]^{p \times m} \mid \exists \mathcal{A} \in \mathcal{F}_{\bar{\mathbb{N}}_{\max}, \gamma}^{\text{per}, c}[\gamma]^{m \times m} \text{ such that } \mathcal{G} = \mathcal{H}\mathcal{A}^* \right\} \\ \cup \left\{ \mathcal{G} \in \mathcal{F}_{\bar{\mathbb{N}}_{\max}, \gamma}^{\text{per}, c}[\gamma]^{p \times m} \mid \exists \mathcal{A} \in \mathcal{F}_{\bar{\mathbb{N}}_{\max}, \gamma}^{\text{per}, c}[\gamma]^{p \times p} \text{ such that } \mathcal{G} = \mathcal{A}^*\mathcal{H} \right\}$$

and the greatest solution, denoted  $\mathcal{F}_{\max}$ , is given by

$$\mathcal{F}_{\max} = \mathcal{H} \setminus \mathcal{G} \setminus \mathcal{H}$$

The previous reasoning is not constructive and does not lead to a practical implementation of  $\mathcal{F}_{\max}$ . In practice, the feedback can only use information from the past to compute occurrences of input events. Hence, the feedback  $\mathcal{F}$  is required to be causal. In the following, we only consider the case of a transfer function matrix  $\mathcal{H}$  in  $\mathcal{F}_{\bar{\mathbb{N}}_{\max}, \gamma}^{\text{per}, c}[\gamma]^{m \times p}$  and a reference model  $\mathcal{G}$  in  $\mathcal{F}_{\bar{\mathbb{N}}_{\max}, \gamma}^{\text{per}, c}[\gamma]^{m \times p}$  such that  $\mathcal{G} = \mathcal{H}\mathcal{A}^*$  with  $\mathcal{A}$  in  $\mathcal{F}_{\bar{\mathbb{N}}_{\max}, \gamma}^{\text{per}, c}[\gamma]^{p \times p}$ . Then,

$$(\mathcal{H}\mathcal{F})^* \mathcal{H} \leq \mathcal{G} \Leftrightarrow (\mathcal{H}\mathcal{F})^* \leq \mathcal{G}_{\phi_{++}} \mathcal{H} \text{ as } (\mathcal{H}\mathcal{F})^* \text{ is causal}$$

Furthermore, as entries of  $\mathcal{G}$  and  $\mathcal{H}$  belong to  $\mathcal{F}_{\bar{\mathbb{N}}_{\max}, \gamma}^{\text{per}, c}[\gamma]^{m \times p}$ , entries of  $\mathcal{G}_{\phi_{++}} \mathcal{H}$  belong to  $\mathcal{F}_{\bar{\mathbb{N}}_{\max}, \gamma}^{\text{per}, c}[\gamma]^{m \times p}$  according to Prop. 37. As  $\mathcal{G} \geq \mathcal{X}\mathcal{H} \Leftrightarrow \mathcal{G} \geq \mathcal{X}\mathcal{G}$ ,

$$\mathcal{G}_{\phi_{++}} \mathcal{H} = \mathcal{G}_{\phi_{++}} \mathcal{G}$$

Furthermore, as  $\mathcal{X}\mathcal{G} \leq \mathcal{G} \Rightarrow \mathcal{X}^2\mathcal{G} \leq \mathcal{G}$ ,

$$(\mathcal{G}_{\phi_{++}} \mathcal{H})^* = (\mathcal{G}_{\phi_{++}} \mathcal{G})^* = \mathcal{G}_{\phi_{++}} \mathcal{G} = \mathcal{G}_{\phi_{++}} \mathcal{H}$$

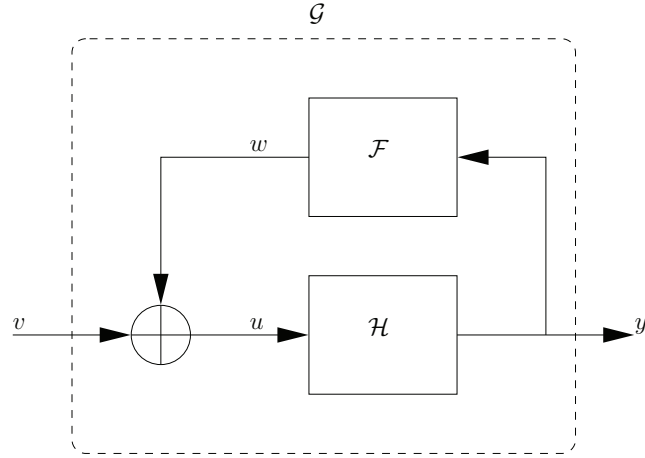

Figure 8.4.: Model reference control with output feedback

Hence,

$$\begin{aligned} (\mathcal{H}\mathcal{F})^* \leq \mathcal{G} \phi_{++} \mathcal{H} &\Leftrightarrow \mathcal{H}\mathcal{F} \leq \mathcal{G} \phi_{++} \mathcal{H} \\ &\Leftrightarrow \mathcal{F} \leq \mathcal{H} \phi_{++} \mathcal{G} \phi_{++} \mathcal{H} \end{aligned}$$

Therefore, according to Prop. 36,  $\mathcal{F}_{\max} = \mathcal{H} \phi_{++} \mathcal{G} \phi_{++} \mathcal{H}$  belongs to  $\mathcal{F}_{\bar{\mathbb{N}}_{\max, \gamma}}^{\text{per}, c}[\gamma]^{p \times m}$ . Thus, according to the fundamental theorem in  $\mathcal{F}_{\bar{\mathbb{N}}_{\max, \gamma}}[\gamma]$ ,  $\mathcal{F}_{\max}$  is realizable (i.e.,  $\mathcal{F}_{\max}$  can be seen as the transfer function matrix of a  $(\max, +)$ -system subject to partial synchronization). This leads to a practical implementation of  $\mathcal{F}_{\max}$ . Using a similar reasoning, it is possible to deal with a reference model  $\mathcal{G}$  in  $\mathcal{F}_{\bar{\mathbb{N}}_{\max, \gamma}}^{\text{per}, c}[\gamma]^{m \times p}$  such that  $\mathcal{G} = \mathcal{A}^* \mathcal{H}$  with  $\mathcal{A}$  in  $\mathcal{F}_{\bar{\mathbb{N}}_{\max, \gamma}}[\gamma]^{m \times m}$ . Then, for a  $(\max, +)$ -system subject to partial synchronization with a transfer function matrix  $\mathcal{H}$  in  $\mathcal{F}_{\bar{\mathbb{N}}_{\max, \gamma}}^{\text{per}, c}[\gamma]^{m \times p}$ , we provide an algorithm to compute and realize the feedback for a model reference  $\mathcal{G}$  in  $\mathcal{G}^{\text{per}, c}$  with

$$\begin{aligned} \mathcal{G}^{\text{per}, c} &= \left\{ \mathcal{G} \in \mathcal{F}_{\bar{\mathbb{N}}_{\max, \gamma}}^{\text{per}, c}[\gamma]^{p \times m} \mid \exists \mathcal{A} \in \mathcal{F}_{\bar{\mathbb{N}}_{\max, \gamma}}[\gamma]^{m \times m} \text{ such that } \mathcal{G} = \mathcal{H}\mathcal{A}^* \right\} \\ &\cup \left\{ \mathcal{G} \in \mathcal{F}_{\bar{\mathbb{N}}_{\max, \gamma}}^{\text{per}, c}[\gamma]^{p \times m} \mid \exists \mathcal{A} \in \mathcal{F}_{\bar{\mathbb{N}}_{\max, \gamma}}[\gamma]^{p \times p} \text{ such that } \mathcal{G} = \mathcal{A}^* \mathcal{H} \right\} \end{aligned}$$

**Remark 25** (Neutral feedback). *An interesting particular case is choosing  $\mathcal{G} = \mathcal{H}$ . Then,  $\mathcal{F}_{\max} = \mathcal{H} \phi_{++} \mathcal{H} \phi_{++} \mathcal{H}$ . In the literature, this feedback is called neutral feedback as it does not modify the transfer function matrix of the system, i.e.,  $(\mathcal{H}\mathcal{F}_{\max})^* \mathcal{H} = \mathcal{H}$ . Note that if  $\mathcal{H}$  belongs to  $\mathcal{F}_{\bar{\mathbb{N}}_{\max, \gamma}}^{\text{per}, c}[\gamma]^{p \times m}$ , then model reference  $\mathcal{G} = \mathcal{H}$  belongs to  $\mathcal{G}^{\text{per}, c}$ .*

**Example 45.** *In the following, the neutral feedback, denoted  $\mathcal{F}_{\max}$ , for the  $(\max, +)$ -system subject to partial synchronization introduced in Ex. 35 (i.e., a one-way road equipped with two*

traffic lights) is computed. The transfer function  $\mathcal{H}$  of this system has already been computed in Ex. 40 and belongs to  $\mathcal{F}_{\mathbb{N}_{\max}, \gamma}^{\text{per}, c}[\gamma]$ . Hence, we can compute and realize the feedback  $\mathcal{F}_{\max}$ . Thus,

$$\mathcal{F}_{\max} = \mathcal{H} \setminus_{++} \mathcal{H} \phi_{++} \mathcal{H} = (\Delta^{12} \gamma^3)^* (p_1 \oplus p_2 \gamma \oplus p_3 \gamma^2) \gamma^6$$

with

$$p_1(x) = \begin{cases} x & \text{if } x \in \{\varepsilon, \top\} \\ 26 & \text{if } e \leq x < 21 \\ 26 \otimes 6^k & \text{if } 21 \otimes 6^k \leq x < 25 \otimes 6^k \text{ with } k \in \mathbb{N}_0 \\ 27 \otimes 6^k & \text{if } x = 25 \otimes 6^k \text{ with } k \in \mathbb{N}_0 \\ 28 \otimes 6^k & \text{if } x = 26 \otimes 6^k \text{ with } k \in \mathbb{N}_0 \end{cases}$$

$$p_2(x) = \begin{cases} x & \text{if } x \in \{\varepsilon, \top\} \\ 27 & \text{if } e \leq x < 20 \\ 27 \otimes 6^k & \text{if } 20 \otimes 6^k \leq x < 25 \otimes 6^k \text{ with } k \in \mathbb{N}_0 \\ 28 \otimes 6^k & \text{if } x = 25 \otimes 6^k \text{ with } k \in \mathbb{N}_0 \end{cases}$$

$$p_3(x) = \begin{cases} x & \text{if } x \in \{\varepsilon, \top\} \\ 28 & \text{if } e \leq x < 19 \\ 28 \otimes 6^k & \text{if } 19 \otimes 6^k \leq x < 25 \otimes 6^k \text{ with } k \in \mathbb{N}_0 \end{cases}$$

A graphical representation of the neutral feedback  $\mathcal{F}_{\max}$  is drawn in Fig. 8.5. Furthermore, a realization of  $\mathcal{F}_{\max}$  as  $(\max, +)$ -system subject to partial synchronization is provided in Fig. 8.6.

**Example 46.** In the following, the neutral feedback, denoted  $\mathcal{F}_{\max}$ , for the  $(\max, +)$ -system subject to partial synchronization introduced in Ex. 42 is computed. As  $\mathcal{H}$  does not belong to  $\mathcal{F}_{\mathbb{N}_{\max}, \gamma}^{\text{per}, c}[\gamma]$ , no algorithm has been providing to compute  $\mathcal{F}_{\mathbb{N}_{\max}, \gamma}[\gamma]$ . However, as  $\mathcal{H} = \mathcal{H}^*$ , finding the neutral feedback  $\mathcal{F}_{\max}$  is equivalent to finding the greatest causal solution of  $(\mathcal{H}^* \mathcal{F})^* \mathcal{H}^* \leq \mathcal{H}^*$ . Consequently,  $\mathcal{F}_{\max} = \mathcal{H}^* = \mathcal{H}$ .

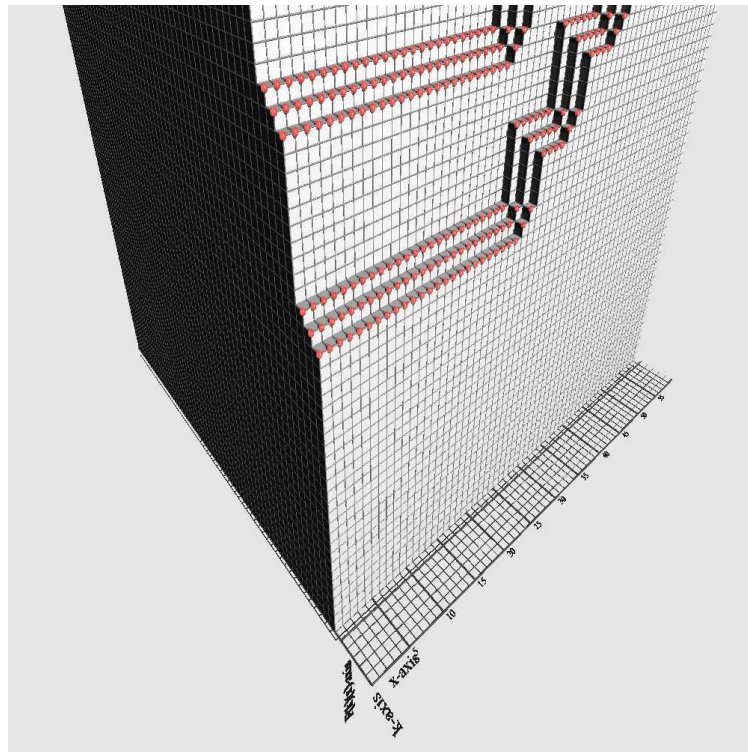

Figure 8.5.: Neutral feedback for the road equipped with traffic lights

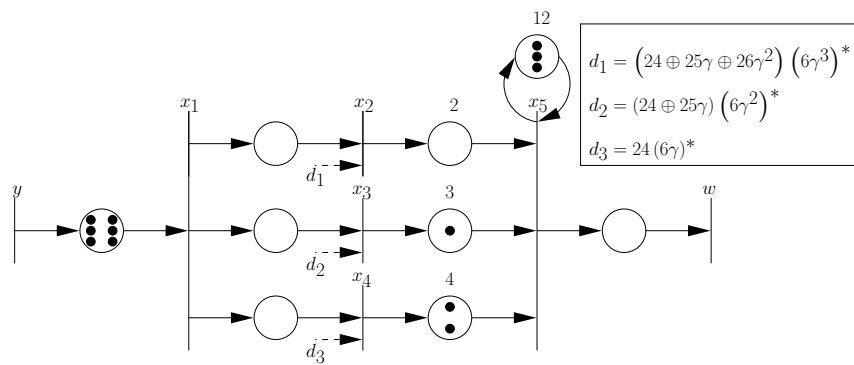

Figure 8.6.: Realization of the neutral feedback for the road equipped with traffic lights

## Conclusion

---

In the literature, discrete event systems ruled only by standard synchronization (e.g., for all  $k \geq l$ , occurrence  $k$  of event  $e_2$  is at least  $\tau$  units of time after occurrence  $k-l$  of event  $e_1$ ) are widely considered [1, 6, 26]. These systems are called  $(\max, +)$ -linear systems, as they admit a linear state-space representation in the  $(\max, +)$ -algebra. Many applications for  $(\max, +)$ -linear systems are found in the fields of manufacturing systems and transportation networks. Based on an analogy with standard control theory, modeling and control strategies have been developed for  $(\max, +)$ -linear systems such as transfer function matrix [1, 8, 22, 32], optimal feedforward control [9, 31], model reference control [14, 30], and model predictive control [20, 34]. In this work, we extend these tools to a class of discrete event systems ruled by standard synchronization and partial synchronization (e.g., event  $e_2$  can only occur *when*, not after, event  $e_1$  occurs). Partial synchronization often appears in transportation networks. For example, a vehicle can cross an intersection only *when* the associated traffic light is green or a user can take a bus only *when* a bus is at the bus stop.

The first contribution relates to  $(\max, +)$ -systems with partial synchronization, i.e., discrete event systems split into a main system and a secondary system such that there exist only standard synchronizations between events in the same system and partial synchronizations of events in the secondary system by events in the main system. A modeling in the  $(\max, +)$ -algebra based on daters is introduced for  $(\max, +)$ -systems with partial synchronization. Furthermore, predicting the output induced by a predefined input corresponds to solving a recursive equation in the event domain. This leads to an input-output mapping for  $(\max, +)$ -systems with partial synchronization. The main difference between

(max, +)-linear systems and (max, +)-systems with partial synchronization is that the input-output mapping associated with a (max, +)-system with partial synchronization may not be isotone. Therefore, operatorial representation (used to get transfer function matrices for (max, +)-linear systems) cannot be extended to (max, +)-systems with partial synchronization. Hence, transfer function matrices are not available to model (max, +)-systems with partial synchronization. Concerning the control of (max, +)-systems with partial synchronization, optimal feedforward control has been extended. The aim of this control approach is to respect an output reference (*i.e.*, ensure that output events meet a deadline) under the just-in-time condition (*i.e.*, input events occur as late as possible). This problem is reformulated in terms of cost functions and the optimal input is computed when priority is given to the main system over the secondary system (*i.e.*, the performance of the main system is never degraded only to improve the performance of the secondary system). Model predictive control is also extended to (max, +)-systems with partial synchronization. This control approach consists in a closed-loop version of optimal feedforward control. For each time step, the optimal input is computed over a prediction horizon, but only the occurrences of input events in the next time step are applied to the system. The main advantage of model predictive control in comparison with optimal feedforward control is the ability to take into account changes in the output reference and perturbations. The main disadvantage is the computational cost associated with the online calculation of the optimal input. In the selected approach, this computational cost is linear with the length of the prediction horizon. Model reference control is not extended to (max, +)-system with partial synchronization, as transfer function matrices are not available. The previous methods are illustrated with a supply chain for containers using a rail transport section. Therefore, a container can only leave a train station by train *when* a train is leaving the train station. Hence, the train line corresponds to the main system and the supply chain corresponds to the secondary system. As the train line may be shared by several supply chains, it makes sense not to degrade the performance of the train line only to improve the performance of a single supply chain.

The second contribution relates to (max, +)-systems subject to partial synchronization, *i.e.*, (max, +)-systems with partial synchronization where the behavior of the main system is predefined. Hence, a (max, +)-system subject to partial synchronization corresponds to a (max, +)-linear system, where occurrence times of events belong to predefined sets. All techniques developed for (max, +)-systems with partial synchronization are available for (max, +)-systems subject to partial synchronization. Furthermore, operatorial representation is extended and leads to transfer function matrices for (max, +)-systems subject to partial synchronization. A convenient dioid to express these transfer function matrices is  $\mathcal{F}_{\overline{\mathbb{N}}_{\max}, \gamma}[\llbracket \gamma \rrbracket]$ , a dioid of isotone formal power series in  $\gamma$  with residuated mappings over  $\overline{\mathbb{N}}_{\max}$  as coefficients. A major achievement is the fundamental theorem in  $\mathcal{F}_{\overline{\mathbb{N}}_{\max}, \gamma}[\llbracket \gamma \rrbracket]$  which provides methods to compute transfer function matrices and to find (max, +)-systems subject to partial synchronization associated with a predefined transfer function matrix. Then,

---

model reference control is extended to  $(\max, +)$ -systems subject to partial synchronization. The aim of this approach is to match a model reference by modifying the dynamics of the system. In particular, the use of prefilters and feedbacks is investigated. The results are obtained by analogy with model reference control for  $(\max, +)$ -linear systems. But, for feedbacks, some additional assumptions have to be made on the transfer function matrix and the model reference. The previous methods are illustrated with a road equipped with traffic lights. As the behavior of the traffic lights is predetermined, this system corresponds to a  $(\max, +)$ -system subject to partial synchronization.

An ambitious goal for future work is to develop a theory for discrete event systems ruled by standard and partial synchronizations instead of considering only specific structures. Getting handy transfer function matrices for this class of systems might be tricky, as a reasoning based on operatorial representation is not possible. It is also of interest to investigate the dual in the event domain of partial synchronization. Then, the class of systems dual to  $(\max, +)$ -systems subject to partial synchronization leads to transfer function matrices which are formal power series in  $\delta$ . Similarities between such systems and weight-balanced timed event graphs or time-varying  $(\max, +)$ -systems, investigated in [15, 16], are expected.





**Part III.**  
**Appendices**



# A

## Proofs

---

### A.1. Calculation with Periodic Series in $\mathcal{F}_{\overline{\mathbb{N}}_{\max}, \gamma}[\gamma]$

#### A.1.1. Sum of Periodic Series

**Proposition 41** (Sum of periodic series). *Let  $s_1$  and  $s_2$  be two periodic series in  $\mathcal{F}_{\overline{\mathbb{N}}_{\max}, \gamma}[\gamma]$ . Series  $s_1 \oplus s_2$  is periodic. If  $s_1$  and  $s_2$  are different from  $\varepsilon$ , then*

$$\sigma(s_1 \oplus s_2) = \min(\sigma(s_1), \sigma(s_2))$$

*Proof.* For  $i \in \{1, 2\}$ , there exist  $N_i \in \mathbb{N}$ , periodic mappings  $f_{i,1}, \dots, f_{i,N_i}$  in  $\mathcal{F}_{\overline{\mathbb{N}}_{\max}}$ ,  $n_{i,1}, \dots, n_{i,N_i}$  in  $\mathbb{N}_0$ ,  $\tau_{i,1}, \dots, \tau_{i,N_i}$  in  $\mathbb{N}_0$ , and  $\nu_i$  in  $\mathbb{N}$  such that

$$s_i = \bigoplus_{k=1}^{N_i} (\Delta^{\tau_{i,k}} \gamma^{\nu_i})^* f_{i,k} \gamma^{n_{i,k}}$$

Let us define  $\nu$ ,  $m_1$ , and  $m_2$  by

$$\nu = \text{lcm}(\nu_1, \nu_2) = m_1 \nu_1 = m_2 \nu_2$$

Then,

$$\forall i \in \{1, 2\}, \quad s_i = \bigoplus_{k=1}^{N_i} \bigoplus_{l=0}^{m_i-1} (\Delta^{m_i \tau_{i,k}} \gamma^{\nu})^* \Delta^{l \tau_{i,k}} f_{i,k} \gamma^{n_{i,k} + l \nu_i}$$

Therefore, by definition,  $s_1 \oplus s_2$  is a periodic series. Besides, according to Lem. 38, there exist  $X_1, X_2 \in \mathbb{N}_0$  and  $\omega_1, \omega_2 \in \mathbb{N}$  such that

$$\begin{aligned} \forall x \geq X_1, \quad \psi(s_1)(\omega_1 x) &= \omega_1 \psi(s_1)(x) \\ \forall x \geq X_2, \quad \psi(s_2)(\omega_2 x) &= \omega_2 \psi(s_2)(x) \end{aligned}$$

Therefore, with  $X = X_1 \oplus X_2$  and  $\omega = \text{lcm}(\omega_1, \omega_2)$ ,

$$\begin{aligned} \forall x \geq X, \quad \psi(s_1 \oplus s_2)(\omega x) &= \omega \psi(s_1)(x) \oplus \omega \psi(s_2)(x) \\ &= \omega \psi(s_1 \oplus s_2)(x) \end{aligned}$$

According to Def. 43 and Lem. 40,

$$\begin{aligned} \sigma(s_1 \oplus s_2) &= \sigma(\psi(s_1 \oplus s_2)(X)) \\ &= \sigma(\psi(s_1)(X) \oplus \psi(s_2)(X)) \\ &= \min(\sigma(\psi(s_1)(X)), \sigma(\psi(s_2)(X))) \\ &= \min(\sigma(s_1), \sigma(s_2)) \end{aligned}$$

□

### A.1.2. Greatest Lower Bound of Periodic Series

Before starting with the proof of Prop. 29, two intermediate lemmas are introduced to handle the degenerated cases.

**Lemma 50.** *Let  $f_1$  and  $f_2$  be two mappings in  $\mathcal{F}_{\overline{\mathbb{N}}_{\max}}$  and  $n_1, n_2 \in \mathbb{N}_0$ .*

$$f_1 \gamma^{n_1} \wedge f_2 \gamma^{n_2} = (f_1 \wedge f_2) \gamma^{\max(n_1, n_2)}$$

*Proof.*

$$\forall k \in \mathbb{Z}, \quad (f_1 \gamma^{n_1})(k) = \begin{cases} \varepsilon & \text{if } k < n_1 \\ f_1 & \text{if } k \geq n_1 \end{cases} \quad \text{and} \quad (f_2 \gamma^{n_2})(k) = \begin{cases} \varepsilon & \text{if } k < n_2 \\ f_2 & \text{if } k \geq n_2 \end{cases}$$

Hence,

$$\begin{aligned} (f_1 \gamma^{n_1} \wedge f_2 \gamma^{n_2})(k) &= (f_1 \gamma^{n_1})(k) \wedge (f_2 \gamma^{n_2})(k) \\ &= \begin{cases} \varepsilon & \text{if } k < \max(n_1, n_2) \\ f_1 \wedge f_2 & \text{if } k \geq \max(n_1, n_2) \end{cases} \end{aligned}$$

Thus,  $f_1 \gamma^{n_1} \wedge f_2 \gamma^{n_2} = (f_1 \wedge f_2) \gamma^{\max(n_1, n_2)}$ .

□

**Lemma 51.** Let  $f_1$  be a periodic mapping in  $\mathcal{F}_{\overline{\mathbb{N}}_{\max}}$ ,  $s_2$  be a periodic series in  $\mathcal{F}_{\overline{\mathbb{N}}_{\max}, \gamma}[\llbracket \gamma \rrbracket]$ , and  $n_1$  in  $\mathbb{N}_0$ . Series  $f_1 \gamma^{n_1} \wedge s_2$  is periodic.

*Proof.* As  $s_2$  is a periodic series in  $\mathcal{F}_{\overline{\mathbb{N}}_{\max}, \gamma}[\llbracket \gamma \rrbracket]$ , there exist  $N$  in  $\mathbb{N}$ , periodic mappings  $f_{2,1}, \dots, f_{2,N}$  in  $\mathcal{F}_{\overline{\mathbb{N}}_{\max}}$ ,  $n_{2,1}, \dots, n_{2,N}$  in  $\mathbb{N}_0$ ,  $\tau_1, \dots, \tau_N$  in  $\mathbb{N}_0$ , and  $\nu$  in  $\mathbb{N}$  such that

$$s_2 = \bigoplus_{k=1}^N (\Delta^{\tau_k} \gamma^\nu)^* f_{2,k} \gamma^{n_{2,k}}$$

As  $\mathcal{F}_{\overline{\mathbb{N}}_{\max}, \gamma}[\llbracket \gamma \rrbracket]$  is a distributive dioid,

$$f_1 \gamma^{n_1} \wedge s_2 = \bigoplus_{k=1}^N (f_1 \gamma^{n_1} \wedge (\Delta^{\tau_k} \gamma^\nu)^* f_{2,k} \gamma^{n_{2,k}})$$

Therefore, according to Prop. 28, to prove the periodicity of  $f_1 \gamma^{n_1} \wedge s_2$ , it is sufficient to show that  $s$  is a periodic series, where  $s = f_1 \gamma^{n_1} \wedge (\Delta^\tau \gamma^\nu)^* f_2 \gamma^{n_2}$  with periodic mappings  $f_1, f_2$  in  $\mathcal{F}_{\overline{\mathbb{N}}_{\max}}$ ,  $n_1, n_2 \in \mathbb{Z}$ ,  $\nu \in \mathbb{N}$ , and  $\tau \in \mathbb{N}_0$ . Furthermore, as, for all  $L$  in  $\mathbb{N}$ ,

$$\begin{aligned} f_1 \gamma^{n_1} \wedge (\Delta^\tau \gamma^\nu)^* f_2 \gamma^{n_2} &= \bigoplus_{l=0}^{L-1} (f_1 \gamma^{n_1} \wedge \Delta^{l\tau} f_2 \gamma^{n_2 + l\nu}) \\ &\quad \oplus (f_1 \gamma^{n_1} \wedge (\Delta^\tau \gamma^\nu)^* \Delta^{L\tau} f_2 \gamma^{n_2 + L\nu}) \end{aligned}$$

Therefore, according to Prop. 28, it is sufficient to consider the case where  $n_2 \geq n_1$ .

If  $f_1$  or  $f_2$  is equal to  $\varepsilon$ , then  $s = \varepsilon$  is a periodic series. The case  $\tau = 0$  has been solved in Lem. 50. In the following, we assume that  $f_1, f_2$  are non-zero mappings and  $\tau > 0$ . For all  $k \in \mathbb{Z}$ ,

$$\begin{aligned} (f_1 \gamma^{n_1})(k) &= \begin{cases} \varepsilon & \text{if } k < n_1 \\ f_1 & \text{if } k \geq n_1 \end{cases} \\ ((\Delta^\tau \gamma^\nu)^* f_2 \gamma^{n_2})(k) &= \begin{cases} \varepsilon & \text{if } k < n_2 \\ \Delta^{j\tau} f_2 & \text{if } n_2 + j\nu \leq k < n_2 + (j+1)\nu \text{ with } j \in \mathbb{N}_0 \end{cases} \end{aligned}$$

Then, for all  $k \in \mathbb{Z}$ ,

$$s(k) = \begin{cases} \varepsilon & \text{if } k < n_2 \\ f_1 \wedge \Delta^{j\tau} f_2 & \text{if } n_2 + j\nu \leq k < n_2 + (j+1)\nu \text{ with } j \in \mathbb{N}_0 \end{cases}$$

Furthermore, as  $f_1$  and  $f_2$  are non-zero mappings,  $Y_1 = \bigwedge \{x \in \overline{\mathbb{N}}_{\max} \mid f_1(x) > \varepsilon\}$  and  $Y_2 = \bigwedge \{x \in \overline{\mathbb{N}}_{\max} \mid f_2(x) > \varepsilon\}$  belong to  $\mathbb{N}_0$ . According to Prop. 1,

$$\forall j \in \mathbb{N}_0, \quad (f_1 \wedge \Delta^{j\tau} f_2)(x) = \begin{cases} \varepsilon & \text{if } x < Y \\ f_1(x) \wedge \tau^j f_2(x) & \text{if } x \geq Y \end{cases}$$

with  $Y = Y_1 \oplus Y_2$ . By decomposing  $f_1$  in a sum of two periodic mappings in  $\mathcal{F}_{\overline{\mathbb{N}}_{\max}}$ , we can assume that either  $f_1(x) \neq \top$  for all  $x \in \mathbb{N}_0$  or  $f_1(Y_1) = \top$ .

If  $f_1(x) \neq \top$  for all  $x \in \mathbb{N}_0$ ,  $f_1(x)$  is finite for all  $x \in \mathbb{N}_0$  greater than or equal to  $Y$ . Then there exists  $K \in \mathbb{N}_0$  such that

$$\forall j \geq K, \forall x \geq Y, \quad f_1(x) \wedge \tau^j f_2(x) = f_1(x)$$

Thus,

$$s = \bigoplus_{j=0}^K \left( f_1 \wedge \Delta^{j\tau} f_2 \right) \gamma^{n_2 + j\nu}$$

Hence,  $s$  is a periodic series.

Otherwise,  $f_1(Y_1) = \top$ . This leads to

$$\left( f_1 \wedge \Delta^{j\tau} f_2 \right) (x) = \begin{cases} \varepsilon & \text{if } x < Y \\ \tau^j f_2(x) & \text{if } x \geq Y \end{cases}$$

Then,

$$f_1 \wedge \Delta^{j\tau} f_2 = \Delta^{j\tau} \tilde{f}_2 \text{ with } \tilde{f}_2(x) = \begin{cases} \varepsilon & \text{if } x < Y \\ f_2(x) & \text{if } x \geq Y \end{cases}$$

Thus,

$$s = (\Delta^\tau \gamma^\nu)^* \tilde{f}_2 \gamma^{n_2}$$

Hence,  $s$  is a periodic series. □

**Proposition 42** (Greatest lower bound of periodic series). *Let  $s_1$  and  $s_2$  be two periodic series in  $\mathcal{F}_{\overline{\mathbb{N}}_{\max}, \gamma}[\![\gamma]\!]$ . Series  $s_1 \wedge s_2$  is periodic. If  $s_1$  and  $s_2$  are different from  $\varepsilon$ , then*

$$\sigma(s_1 \wedge s_2) = \max(\sigma(s_1), \sigma(s_2))$$

*Proof.*  $s_1$  and  $s_2$  are periodic series in  $\mathcal{F}_{\overline{\mathbb{N}}_{\max}, \gamma}[\![\gamma]\!]$ . For  $i \in \{1, 2\}$ , there exist  $N_i \in \mathbb{N}$ , periodic mappings  $f_{i,1}, \dots, f_{i,N_i}$  in  $\mathcal{F}_{\overline{\mathbb{N}}_{\max}}$ ,  $n_{i,1}, \dots, n_{i,N_i}$  in  $\mathbb{N}_0$ ,  $\tau_{i,1}, \dots, \tau_{i,N_i}$  in  $\mathbb{N}_0$ , and  $\nu_i$  in  $\mathbb{N}$  such that

$$s_i = \bigoplus_{k=1}^{N_i} (\Delta^{\tau_{i,k}} \gamma^{\nu_i})^* f_{i,k} \gamma^{n_{i,k}}$$

As  $\mathcal{F}_{\overline{\mathbb{N}}_{\max}, \gamma}[\![\gamma]\!]$  is distributive,

$$\begin{aligned} s_1 \wedge s_2 &= \bigoplus_{k=1}^{N_1} (\Delta^{\tau_{1,k}} \gamma^{\nu_1})^* f_{1,k} \gamma^{n_{1,k}} \wedge \bigoplus_{j=1}^{N_2} (\Delta^{\tau_{2,j}} \gamma^{\nu_2})^* f_{2,j} \gamma^{n_{2,j}} \\ &= \bigoplus_{k=1}^{N_1} \bigoplus_{j=1}^{N_2} \left( (\Delta^{\tau_{1,k}} \gamma^{\nu_1})^* f_{1,k} \gamma^{n_{1,k}} \wedge (\Delta^{\tau_{2,j}} \gamma^{\nu_2})^* f_{2,j} \gamma^{n_{2,j}} \right) \end{aligned}$$

According to Prop. 28, it is sufficient to show that

$$s' = (\Delta^{\tau_1} \gamma^{\nu_1})^* f_1 \gamma^{n_1} \wedge (\Delta^{\tau_2} \gamma^{\nu_2})^* f_2 \gamma^{n_2}$$

is a periodic series. The degenerated cases are considered in Lem. 51. Therefore, in the following, we assume that  $\tau_1$  and  $\tau_2$  are strictly greater than 0 and that  $f_1$  and  $f_2$  are non-zero periodic mappings. Furthermore,  $\nu$ ,  $m_1$ ,  $m_2$ ,  $T_1$ , and  $T_2$  are defined by

$$\nu = \text{lcm}(\nu_1, \nu_2) = m_1 \nu_1 = m_2 \nu_2, \quad T_1 = m_1 \tau_1, \quad \text{and} \quad T_2 = m_2 \tau_2$$

Then,

$$\forall i \in \{1, 2\}, \quad (\Delta^{\tau_i} \gamma^{\nu_i})^* f_i \gamma^{n_i} = \bigoplus_{l=0}^{m_i-1} (\Delta^{T_i} \gamma^{\nu})^* \Delta^{l\tau_i} f_i \gamma^{n_i + l\nu_i}$$

As  $\mathcal{F}_{\overline{\mathbb{N}}_{\max}, \gamma}[\gamma]$  is distributive, this leads to

$$s' = \bigoplus_{l=0}^{m_1-1} \bigoplus_{j=0}^{m_2-1} \left( (\Delta^{T_1} \gamma^{\nu})^* \Delta^{l\tau_1} f_1 \gamma^{n_1 + l\nu_1} \wedge (\Delta^{T_2} \gamma^{\nu})^* \Delta^{j\tau_2} f_2 \gamma^{n_2 + j\nu_2} \right)$$

Consequently, it is sufficient to show that

$$s = (\Delta^{T_1} \gamma^{\nu})^* f_1 \gamma^{n_1} \wedge (\Delta^{T_2} \gamma^{\nu})^* f_2 \gamma^{n_2}$$

is a periodic series. From now on, we assume that  $n_2 \geq n_1$ . Then, for  $k \in \mathbb{Z}$ ,

$$\begin{aligned} s(k) &= \left( (\Delta^{T_1} \gamma^{\nu})^* f_1 \gamma^{n_1} \right)(k) \wedge \left( (\Delta^{T_2} \gamma^{\nu})^* f_2 \gamma^{n_2} \right)(k) \\ &= \begin{cases} \varepsilon & \text{if } k < n_2 \\ \Delta^{(K+j)T_1} f_1 \wedge \Delta^{jT_2} f_2 & \text{if } n_2 + j\nu \leq k < n_1 + (K+1+j)\nu \text{ with } j \in \mathbb{N}_0 \\ \Delta^{(K+j+1)T_1} f_1 \wedge \Delta^{jT_2} f_2 & \text{if } n_1 + (K+1+j)\nu \leq k < n_2 + (j+1)\nu \text{ with } j \in \mathbb{N}_0 \end{cases} \end{aligned}$$

with  $K = \lfloor \frac{n_2 - n_1}{\nu} \rfloor$ . Furthermore, as  $f_1$  and  $f_2$  are non-zero mappings,  $Y_1 = \bigwedge \{x \in \overline{\mathbb{N}}_{\max} \mid f_1(x) > \varepsilon\}$  and  $Y_2 = \bigwedge \{x \in \overline{\mathbb{N}}_{\max} \mid f_2(x) > \varepsilon\}$  belong to  $\mathbb{N}_0$ . According to Prop. 1, for  $j \in \mathbb{N}_0$ ,

$$\begin{aligned} \left( \Delta^{(K+j)T_1} f_1 \wedge \Delta^{jT_2} f_2 \right)(x) &= \begin{cases} \varepsilon & \text{if } x < Y \\ T_1^{K+j} f_1(x) \wedge T_2^j f_2(x) & \text{if } x \geq Y \end{cases} \\ \left( \Delta^{(K+j+1)T_1} f_1 \wedge \Delta^{jT_2} f_2 \right)(x) &= \begin{cases} \varepsilon & \text{if } x < Y \\ T_1^{K+j+1} f_1(x) \wedge T_2^j f_2(x) & \text{if } x \geq Y \end{cases} \end{aligned}$$

with  $Y = Y_1 \oplus Y_2$ .

Let us define mappings  $\tilde{f}_1$  and  $\tilde{f}_2$  in  $\mathcal{F}_{\overline{\mathbb{N}}_{\max}}$  by

$$\tilde{f}_1(x) = \begin{cases} \varepsilon & \text{if } x < Y \\ f_1(x) & \text{if } x \geq Y \end{cases} \quad \text{and} \quad \tilde{f}_2(x) = \begin{cases} \varepsilon & \text{if } x < Y \\ f_2(x) & \text{if } x \geq Y \end{cases}$$

**First Case:**  $T_1 > T_2$ . By decomposing  $f_2$  in a sum of two periodic mappings in  $\mathcal{F}_{\mathbb{N}_{\max}}$ , we can assume that either  $f_2(x) \neq \top$  for all  $x \in \mathbb{N}_0$  or  $f_2(Y_2) = \top$ .

If  $f_2(x) \neq \top$  for all  $x \in \mathbb{N}_0$ ,  $f_2(x)$  belongs to  $\mathbb{N}_0$  for all  $x$  in  $\mathbb{N}_0$  greater than or equal to  $Y$ . Then, there exists  $L \in \mathbb{N}_0$  such that

$$\forall j \geq L, \forall x \geq Y, \quad T_1^{K+j} f_1(x) \wedge T_2^j f_2(x) = T_2^j f_2(x)$$

Then,

$$\forall j \geq L, \quad \Delta^{(K+j)T_1} f_1 \wedge \Delta^{jT_2} f_2 = \Delta^{jT_2} \tilde{f}_2$$

Therefore,

$$\begin{aligned} s &= \bigoplus_{j=0}^{+\infty} \left( \Delta^{(K+j)T_1} f_1 \wedge \Delta^{jT_2} f_2 \right) \gamma^{n_2+j\nu} \oplus \bigoplus_{j=0}^{+\infty} \left( \Delta^{(K+j+1)T_1} f_1 \wedge \Delta^{jT_2} f_2 \right) \gamma^{n_1+(K+1+j)\nu} \\ &= p \oplus \bigoplus_{j=L}^{+\infty} \Delta^{jT_2} \tilde{f}_2 \gamma^{n_2+j\nu} \\ &= p \oplus \left( \Delta^{T_2} \gamma^\nu \right)^* \Delta^{LT_2} \tilde{f}_2 \gamma^{n_2+L\nu} \end{aligned}$$

where  $p$  is the polynomial defined by

$$p = \bigoplus_{j=0}^{L-1} \left( \Delta^{(K+j)T_1} f_1 \wedge \Delta^{jT_2} f_2 \right) \gamma^{n_2+j\nu} \oplus \bigoplus_{j=0}^{L-1} \left( \Delta^{(K+j+1)T_1} f_1 \wedge \Delta^{jT_2} f_2 \right) \gamma^{n_1+(K+1+j)\nu}$$

Hence,  $s$  is a periodic series.

Otherwise,  $f_2(Y_2) = \top$ . Then,

$$\begin{aligned} \forall j \in \mathbb{N}_0, \quad \left( \Delta^{(K+j)T_1} f_1 \wedge \Delta^{jT_2} f_2 \right) (x) &= \begin{cases} \varepsilon & \text{if } x < Y \\ T_1^{K+j} f_1(x) & \text{if } x \geq Y \end{cases} \\ \left( \Delta^{(K+j+1)T_1} f_1 \wedge \Delta^{jT_2} f_2 \right) (x) &= \begin{cases} \varepsilon & \text{if } x < Y \\ T_1^{K+j+1} f_1(x) & \text{if } x \geq Y \end{cases} \end{aligned}$$

Thus,

$$\begin{aligned} \forall j \in \mathbb{N}_0, \quad \Delta^{(K+j)T_1} f_1 \wedge \Delta^{jT_2} f_2 &= \Delta^{(K+j)T_1} \tilde{f}_1 \\ \Delta^{(K+j+1)T_1} f_1 \wedge \Delta^{jT_2} f_2 &= \Delta^{(K+j+1)T_1} \tilde{f}_1 \end{aligned}$$



Consequently,

$$\begin{aligned} s &= \bigoplus_{j=0}^{+\infty} \left( \Delta^{(K+j)T_1} f_1 \wedge \Delta^{jT_2} f_2 \right) \gamma^{n_2+j\nu} \oplus \bigoplus_{j=0}^{+\infty} \left( \Delta^{(K+j+1)T_1} f_1 \wedge \Delta^{jT_2} f_2 \right) \gamma^{n_1+(K+1+j)\nu} \\ &= \bigoplus_{j=0}^{+\infty} \Delta^{(K+j)T_1} \tilde{f}_1 \gamma^{n_2+j\nu} \oplus \bigoplus_{j=0}^{+\infty} \Delta^{(K+j+1)T_1} \tilde{f}_1 \gamma^{n_1+(K+1+j)\nu} \\ &= \left( \Delta^{T_1} \gamma^\nu \right)^* \Delta^{KT_1} \tilde{f}_1 \gamma^{n_2} \oplus \left( \Delta^{T_1} \gamma^\nu \right)^* \Delta^{(K+1)T_1} \tilde{f}_1 \gamma^{n_1+(K+1)\nu} \end{aligned}$$

Hence,  $s$  is a periodic series.

**Second Case:**  $T_2 > T_1$ . By decomposing  $f_1$  in a sum of two periodic mappings in  $\mathcal{F}_{\mathbb{N}_{\max}}$ , we can assume that either  $f_1(x) \neq \top$  for all  $x \in \mathbb{N}_0$  or  $f_1(Y_1) = \top$ .

If  $f_1(x) \neq \top$  for all  $x \in \mathbb{N}_0$ ,  $f_1(x)$  belongs to  $\mathbb{N}_0$  for all  $x$  in  $\mathbb{N}_0$  greater than or equal to  $Y$ . Then, there exists  $L \in \mathbb{N}_0$  such that

$$\forall j \geq L, \forall x \geq Y, \quad T_1^{K+j+1} f_1(x) \wedge T_2^j f_2(x) = T_1^{K+j+1} f_1(x)$$

Then,

$$\forall j \geq L, \quad \Delta^{(K+j+1)T_1} f_1 \wedge \Delta^{jT_2} f_2 = \Delta^{(K+j+1)T_1} \tilde{f}_1$$

Therefore,

$$\begin{aligned} s &= \bigoplus_{j=0}^{+\infty} \left( \Delta^{(K+j)T_1} f_1 \wedge \Delta^{jT_2} f_2 \right) \gamma^{n_2+j\nu} \oplus \bigoplus_{j=0}^{+\infty} \left( \Delta^{(K+j+1)T_1} f_1 \wedge \Delta^{jT_2} f_2 \right) \gamma^{n_1+(K+1+j)\nu} \\ &= p \oplus \bigoplus_{j=L}^{+\infty} \Delta^{(K+j)T_1} \tilde{f}_1 \gamma^{n_2+j\nu} \oplus \bigoplus_{j=L}^{+\infty} \Delta^{(K+j+1)T_1} \tilde{f}_1 \gamma^{n_1+(K+1+j)\nu} \\ &= p \oplus \left( \Delta^{T_1} \gamma^\nu \right)^* \Delta^{(K+L)T_1} \tilde{f}_1 \gamma^{n_2+L\nu} \oplus \left( \Delta^{T_1} \gamma^\nu \right)^* \Delta^{(K+L+1)T_1} \tilde{f}_1 \gamma^{n_1+(K+1+L)\nu} \end{aligned}$$

where  $p$  is the polynomial defined by

$$p = \bigoplus_{j=0}^{L-1} \left( \Delta^{(K+j)T_1} f_1 \wedge \Delta^{jT_2} f_2 \right) \gamma^{n_2+j\nu} \oplus \bigoplus_{j=0}^{L-1} \left( \Delta^{(K+j+1)T_1} f_1 \wedge \Delta^{jT_2} f_2 \right) \gamma^{n_1+(K+1+j)\nu}$$

Hence,  $s$  is a periodic series.

Otherwise,  $f_1(Y_1) = \top$ .

$$\begin{aligned} \forall j \in \mathbb{N}_0 \quad \left( \Delta^{(K+j)T_1} f_1 \wedge \Delta^{jT_2} f_2 \right) (x) &= \begin{cases} \varepsilon & \text{if } x < Y \\ T_2^j f_2(x) & \text{if } x \geq Y \end{cases} \\ \left( \Delta^{(K+j+1)T_1} f_1 \wedge \Delta^{jT_2} f_2 \right) (x) &= \begin{cases} \varepsilon & \text{if } x < Y \\ T_2^j f_2(x) & \text{if } x \geq Y \end{cases} \end{aligned}$$

Thus,

$$\begin{aligned}\forall j \in \mathbb{N}_0, \quad \Delta^{(K+j)T_1} f_1 \wedge \Delta^{jT_2} f_2 &= \Delta^{jT_2} \tilde{f}_2 \\ \Delta^{(K+j+1)T_1} f_1 \wedge \Delta^{jT_2} f_2 &= \Delta^{jT_2} \tilde{f}_2\end{aligned}$$

Consequently,

$$\begin{aligned}s &= \bigoplus_{j=0}^{+\infty} \left( \Delta^{(K+j)T_1} f_1 \wedge \Delta^{jT_2} f_2 \right) \gamma^{n_2+j\nu} \oplus \bigoplus_{j=0}^{+\infty} \left( \Delta^{(K+j+1)T_1} f_1 \wedge \Delta^{jT_2} f_2 \right) \gamma^{n_1+(K+1+j)\nu} \\ &= \bigoplus_{j=0}^{+\infty} \Delta^{jT_2} \tilde{f}_2 \gamma^{n_2+j\nu} \oplus \bigoplus_{j=0}^{+\infty} \Delta^{jT_2} \tilde{f}_2 \gamma^{n_1+(K+1+j)\nu} \\ &= \left( \Delta^{T_2} \gamma^\nu \right)^* \tilde{f}_2 \gamma^{n_2}\end{aligned}$$

Hence,  $s$  is a periodic series.

**Third Case:**  $T_1 = T_2 = T$ . According to Lem. 24,

$$\begin{aligned}\Delta^{(K+j)T} f_1 \wedge \Delta^{jT} f_2 &= \Delta^{jT} \left( \Delta^{KT} f_1 \wedge f_2 \right) \\ \Delta^{(K+j+1)T} f_1 \wedge \Delta^{jT} f_2 &= \Delta^{jT} \left( \Delta^{(K+1)T} f_1 \wedge f_2 \right)\end{aligned}$$

Then,

$$\begin{aligned}s &= \bigoplus_{j=0}^{+\infty} \left( \Delta^{(K+j)T} f_1 \wedge \Delta^{jT} f_2 \right) \gamma^{n_2+j\nu} \oplus \bigoplus_{j=0}^{+\infty} \left( \Delta^{(K+j+1)T} f_1 \wedge \Delta^{jT} f_2 \right) \gamma^{n_1+(K+1+j)\nu} \\ &= \left( \Delta^T \gamma^\nu \right)^* \left( \Delta^{KT} f_1 \wedge f_2 \right) \gamma^{n_2} \oplus \left( \Delta^T \gamma^\nu \right)^* \left( \Delta^{(K+1)T} f_1 \wedge f_2 \right) \gamma^{n_1+(K+1)\nu}\end{aligned}$$

Hence,  $s$  is a periodic series.

**Throughput** Series  $s_1$  and  $s_2$  are assumed to be different from  $\varepsilon$ . According to Lem. 38, there exist  $X_1, X_2 \in \mathbb{N}_0$  and  $\omega_1, \omega_2 \in \mathbb{N}$  such that

$$\begin{aligned}\forall x \geq X_1, \quad \psi(s_1)(\omega_1 x) &= \omega_1 \psi(s_1)(x) \\ \forall x \geq X_2, \quad \psi(s_2)(\omega_2 x) &= \omega_2 \psi(s_2)(x)\end{aligned}$$

According to Lem. 34,

$$\forall x \geq X, \quad \psi(s_1 \wedge s_2)(\omega x) = \omega \psi(s_1)(x) \wedge \omega \psi(s_2)(x)$$

with  $X = X_1 \oplus X_2$  and  $\omega = \text{lcm}(\omega_1, \omega_2)$ . Then, for all  $x \geq X$ , as  $\overline{\mathbb{N}}_{\max}$  is a selective dioid,

$$\begin{aligned} \forall k \in \mathbb{Z}, \quad \psi(s_1 \wedge s_2)(\omega x)(k) &= \omega \psi(s_1)(x)(k) \wedge \omega \psi(s_2)(x)(k) \\ &= \omega(\psi(s_1)(x)(k) \wedge \psi(s_2)(x)(k)) \\ &= \omega(\psi(s_1)(x) \wedge \psi(s_2)(x))(k) \\ &= \omega \psi(s_1 \wedge s_2)(x)(k) \end{aligned}$$

Consequently,

$$\forall x \geq X, \quad \psi(s_1 \wedge s_2)(\omega x) = \omega \psi(s_1 \wedge s_2)(x)$$

According to Def. 43 and Lem. 40,

$$\begin{aligned} \sigma(s_1 \wedge s_2) &= \sigma(\psi(s_1 \wedge s_2)(X)) \\ &= \sigma(\psi(s_1)(X) \wedge \psi(s_2)(X)) \\ &= \max(\sigma(\psi(s_1)(X)), \sigma(\psi(s_2)(X))) \\ &= \max(\sigma(s_1), \sigma(s_2)) \end{aligned}$$

□

### A.1.3. Product of Periodic Series

Before starting with the proof of Prop. 30, two intermediate lemmas are introduced. The next lemma gives a simple expression of the throughput of a non-zero periodic series  $s$  in  $\mathcal{F}_{\overline{\mathbb{N}}_{\max}, \gamma} \llbracket \gamma \rrbracket$  without using the slicing mapping  $\psi$ .

**Lemma 52.** *Let  $s$  be a non-zero periodic series such that  $s = \bigoplus_{k=1}^N (\Delta^{\tau_k} \gamma^{\nu_k})^* f_k \gamma^{\eta_k}$  with  $N$  in  $\mathbb{N}$ , non-zero periodic mappings  $f_1, \dots, f_N$  in  $\mathcal{F}_{\overline{\mathbb{N}}_{\max}, \gamma} \llbracket \gamma \rrbracket$ ,  $\eta_1, \dots, \eta_N$  in  $\mathbb{N}_0$ ,  $\tau_1, \dots, \tau_N$  in  $\mathbb{N}_0$ , and  $\nu$  in  $\mathbb{N}$ .*

$$\sigma(s) = \begin{cases} 0 & \text{if there exists } k \text{ and } x \in \mathbb{N}_0 \text{ such that } f_k(x) = \top \\ \min_{1 \leq k \leq N} \left( \frac{\nu}{\tau_k} \right) & \text{otherwise} \end{cases}$$

*Proof.* If there exist  $k$  and  $x \in \mathbb{N}_0$  such that  $f_k(x) = \top$ ,

$$\sigma(s) \leq \sigma(\psi(s)(x)) = 0$$

Then,  $\sigma(s) = 0$ .

Otherwise, we assume that mapping  $f_k$  is periodic with respect to  $X_k \in \mathbb{N}_0$  and  $\omega_k \in \mathbb{N}$ . Let  $X = \bigoplus_{k=1}^N X_k$ , according to Lem. 40 and Prop. 28,

$$\begin{aligned} \sigma(s) &= \sigma(\psi(s)(X)) \\ &= \sigma\left(\bigoplus_{k=1}^N (\tau_k \gamma^\nu)^* f_k(X) \gamma^{n_k}\right) \\ &= \min_{1 \leq k \leq N} \sigma((\tau_k \gamma^\nu)^* f_k(X) \gamma^{n_k}) \\ &= \min_{1 \leq k \leq N} \frac{\nu}{\tau_k} \text{ as } f_k(X) \in \mathbb{N}_0 \end{aligned}$$

□

**Lemma 53.** *Let  $s$  be a series in  $\mathcal{F}_{\overline{\mathbb{N}}_{\max}, \gamma}[[\gamma]]$  such that  $s = f\gamma^n (\Delta^\tau \gamma^\nu)^*$  with a periodic mapping  $f$  in  $\mathcal{F}_{\overline{\mathbb{N}}_{\max}}$ ,  $n \in \mathbb{N}_0$ ,  $\nu \in \mathbb{N}$ , and  $\tau \in \mathbb{N}_0$ . Then,  $s$  can be written under the form*

$$s = p \oplus (\Delta^{\tau'} \gamma^{\nu'})^* q$$

with  $p, q$  polynomials with coefficients of the form  $f\Delta^j$  where  $j \in \mathbb{N}_0$ ,  $\tau'$  in  $\mathbb{N}_0$ , and  $\nu'$  in  $\mathbb{N}$  such that  $\frac{\nu'}{\tau'} = \frac{\nu}{\tau}$ .

*Proof.* If  $\tau = 0$ ,  $s = f\gamma^n$  and the result holds.

If  $\tau \neq 0$ ,  $f$  is, by assumption, periodic with respect to  $X \in \mathbb{N}_0$  and  $\omega \in \mathbb{N}$ . Then, there exists  $K \geq 0$  such that  $K\tau \geq X$ . Let  $\tau' = \text{lcm}(\tau, \omega) = m\tau$  and  $\nu' = m\nu$ . Then,

$$s = \bigoplus_{l=0}^{K-1} f\Delta^{l\tau} \gamma^{n+l\nu} \oplus f(\Delta^{\tau'} \gamma^{\nu'})^* \Delta^{K\tau} \gamma^{K\nu+n} \left( \bigoplus_{l=0}^{m-1} \Delta^{l\tau} \gamma^{l\nu} \right)$$

According to Lem. 29,  $f(\Delta^{\tau'} \gamma^{\nu'})^* \Delta^{K\tau} = (\Delta^{\tau'} \gamma^{\nu'})^* f\Delta^{K\tau}$ . Consequently,

$$\begin{aligned} s &= \bigoplus_{l=0}^{K-1} f\Delta^{l\tau} \gamma^{n+l\nu} \oplus (\Delta^{\tau'} \gamma^{\nu'})^* \left( \bigoplus_{l=0}^{m-1} f\Delta^{(K+l)\tau} \gamma^{n+(K+l)\nu} \right) \\ &= p \oplus (\Delta^{\tau'} \gamma^{\nu'})^* q \end{aligned}$$

□

**Proposition 43** (Product of periodic series). *Let  $s_1$  and  $s_2$  be two periodic series in  $\mathcal{F}_{\overline{\mathbb{N}}_{\max}, \gamma}[[\gamma]]$ . Series  $s_1 \otimes s_2$  is periodic. If  $s_1$  and  $s_2$  are different from  $\varepsilon$ , then*

$$\sigma(s_1 \otimes s_2) = \min(\sigma(s_1), \sigma(s_2))$$

*Proof.* For  $i \in \{1, 2\}$ , there exist  $N_i \in \mathbb{N}$ , periodic mappings  $f_{i,1}, \dots, f_{i,N_i}$  in  $\mathcal{F}_{\overline{\mathbb{N}}_{\max}}$ ,  $n_{i,1}, \dots, n_{i,N_i}$  in  $\mathbb{N}_0$ ,  $\tau_{i,1}, \dots, \tau_{i,N_i}$  in  $\mathbb{N}_0$ , and  $\nu_i$  in  $\mathbb{N}$  such that

$$s_i = \bigoplus_{k=1}^{N_i} (\Delta^{\tau_{i,k}} \gamma^{\nu_i})^* f_{i,k} \gamma^{n_{i,k}}$$

Then,

$$s_1 \otimes s_2 = \bigoplus_{k=1}^{N_1} \bigoplus_{j=1}^{N_2} s_{k,j} \text{ with } s_{k,j} = (\Delta^{\tau_{1,k}} \gamma^{\nu_1})^* f_{1,k} (\Delta^{\tau_{2,j}} \gamma^{\nu_2})^* f_{2,j} \gamma^{n_{1,k} + n_{2,j}}$$

According to Prop. 28, to prove that  $s_1 \otimes s_2$  is a periodic series, it is sufficient to show that  $s_{k,j}$  is a periodic series. According to Lem. 53,

$$f_{1,k} \gamma^{n_{1,k} + n_{2,j}} (\Delta^{\tau_{2,j}} \gamma^{\nu_2})^* = p_{k,j} \oplus \left( \Delta^{\tau'_{2,j}} \gamma^{\nu'_{2,j}} \right)^* q_{k,j}$$

with  $\tau'_{2,j} \in \mathbb{N}_0$  and  $\nu'_{2,j} \in \mathbb{N}$  such that  $\frac{\nu'_{2,j}}{\tau'_{2,j}} = \frac{\nu_2}{\tau_{2,j}}$  and  $p_{k,j}, q_{k,j}$  polynomials with periodic coefficients of the form  $f_{1,k} \Delta^{l\tau_{2,j}}$  where  $l \in \mathbb{N}_0$ . Then,

$$s_{k,j} = (\Delta^{\tau_{1,k}} \gamma^{\nu_1})^* p_{k,j} f_{2,j} \oplus (\Delta^{\tau_{1,k}} \gamma^{\nu_1})^* \left( \Delta^{\tau'_{2,j}} \gamma^{\nu'_{2,j}} \right)^* q_{k,j} f_{2,j}$$

Besides, by using results from  $\overline{\mathbb{N}}_{\max, \gamma}[\![\gamma]\!]$ ,

$$(\Delta^{\tau_{1,k}} \gamma^{\nu_1})^* \left( \Delta^{\tau'_{2,j}} \gamma^{\nu'_{2,j}} \right)^* = p'_{k,j} \oplus \left( \Delta^{\tau''_{k,j}} \gamma^{\nu''_{k,j}} \right)^* q'_{k,j}$$

where  $p'_{k,j}, q'_{k,j}$  are polynomials in  $\mathcal{F}_{\Delta, \gamma}[\![\gamma]\!]$ ,  $\tau''_{k,j} \in \mathbb{N}_0$ , and  $\nu''_{k,j} \in \mathbb{N}$  such that

$$\frac{\nu''_{k,j}}{\tau''_{k,j}} = \min \left( \frac{\nu_1}{\tau_{1,k}}, \frac{\nu'_{2,j}}{\tau'_{2,j}} \right) = \min \left( \frac{\nu_1}{\tau_{1,k}}, \frac{\nu_2}{\tau_{2,j}} \right)$$

Hence,

$$s_{k,j} = (\Delta^{\tau_{1,k}} \gamma^{\nu_1})^* p_{k,j} f_{2,j} \oplus p'_{k,j} q_{k,j} f_{2,j} \oplus \left( \Delta^{\tau''_{k,j}} \gamma^{\nu''_{k,j}} \right)^* q'_{k,j} q_{k,j} f_{2,j}$$

is a periodic series. Thus,  $s_1 \otimes s_2$  is a periodic series.

**Throughput** If  $s_1$  and  $s_2$  are non-zero periodic series, we can assume that  $f_{1,k}$  and  $f_{2,j}$  are non-zero periodic mappings. Then,  $s_{k,j}$  are non-zero periodic series. According to Prop. 28,

$$\sigma(s_1 \otimes s_2) = \min_{k,j} \sigma(s_{k,j})$$

If there exist  $k$  (or  $j$ ) and  $x \in \mathbb{N}_0$  such that  $f_{1,k}(x) = \top$  (or  $f_{2,j}(x) = \top$ ), then, according to Lem. 52,  $\sigma(s_{k,j}) = 0$ . Consequently,

$$\sigma(s_1 \otimes s_2) = 0 = \min(\sigma(s_1), \sigma(s_2))$$

Otherwise, according to Lem. 52,

$$\forall k, j, \quad \sigma(s_{k,j}) = \min\left(\frac{\nu_1}{\tau_{1,k}}, \frac{\nu_2}{\tau_{2,j}}\right)$$

Then,

$$\begin{aligned} \sigma(s_1 \otimes s_2) &= \min_{k,j} \left( \min\left(\frac{\nu_1}{\tau_{1,k}}, \frac{\nu_2}{\tau_{2,j}}\right) \right) \\ &= \min\left(\min_k \left(\frac{\nu_1}{\tau_{1,k}}\right), \min_j \left(\frac{\nu_2}{\tau_{2,j}}\right)\right) \end{aligned}$$

Hence, according to Lem. 52,  $\sigma(s_1 \otimes s_2) = \min(\sigma(s_1), \sigma(s_2))$ . □

#### A.1.4. Left-Division of Quasi-Causal Periodic Series

The set of quasi-causal series in  $\mathcal{F}_{\overline{\mathbb{N}}_{\max}, \gamma}[[\gamma]]$  is a complete dioid. Therefore, the product is residuated.  $s_1 \dot{\setminus}_+ s_2$  is the greatest quasi-causal series  $s$  such that  $s_1 \otimes s \leq s_2$ . In the following, the periodicity of  $s_1 \dot{\setminus}_+ s_2$  is investigated when  $s_1$  and  $s_2$  are periodic series. Next, two intermediate lemmas are proved.

**Lemma 54.** *Let  $s$  be a quasi-causal periodic series in  $\mathcal{F}_{\overline{\mathbb{N}}_{\max}, \gamma}[[\gamma]]$  and let  $f$  be a non-zero quasi-causal periodic mapping in  $\mathcal{F}_{\overline{\mathbb{N}}_{\max}}$ . For  $n \in \mathbb{N}_0$ ,  $(f\gamma^n) \dot{\setminus}_+ s$  is a periodic series in  $\mathcal{F}_{\overline{\mathbb{N}}_{\max}, \gamma}[[\gamma]]$ . Furthermore,*

- if  $s = \varepsilon$  or  $\sigma(f\gamma^n) < \sigma(s)$ , then  $(f\gamma^n) \dot{\setminus}_+ s = \varepsilon$ .
- if  $\sigma(f\gamma^n) = \sigma(s) = +\infty$ , then  $(f\gamma^n) \dot{\setminus}_+ s = \varepsilon$  or  $\sigma((f\gamma^n) \dot{\setminus}_+ s) = \sigma(s)$ .
- if  $\sigma(s) \neq +\infty$  and  $\sigma(f\gamma^n) \geq \sigma(s)$ , then  $\sigma((f\gamma^n) \dot{\setminus}_+ s) = \sigma(s)$ .

*Proof.* According to (2.10),

$$\forall l \in \mathbb{Z}, \quad ((f\gamma^n) \dot{\setminus}_+ s)(l) = \begin{cases} \varepsilon & \text{if } l < 0 \\ f \dot{\setminus}_+ s(l+n) & \text{if } l \geq 0 \end{cases}$$

The particular case  $s = \varepsilon$  is first addressed.

$$\forall l \in \mathbb{N}_0, \quad ((f\gamma^n) \dot{\setminus}_+ s)(l) = f \dot{\setminus}_+ \varepsilon$$

As  $f$  is a non-zero mapping, for all  $Z \in \mathbb{N}_0$ , there exists  $z \geq Z$  such that  $f(z) > \varepsilon$ . Consequently, according to Prop. 21,  $f \dot{\setminus}_+ \varepsilon = \varepsilon$ . Thus,  $(f\gamma^n) \dot{\setminus}_+ s = \varepsilon$  and series  $(f\gamma^n) \dot{\setminus}_+ s$  is periodic.

From now on, we assume that  $s \neq \varepsilon$ . Then, according to Prop. 27, there exist  $N \in \mathbb{N}$ , non-zero quasi-causal periodic mappings  $f_1, \dots, f_N$  in  $\mathcal{F}_{\bar{\mathbb{N}}_{\max}}$ ,  $n_1, \dots, n_N$  in  $\mathbb{N}_0$ ,  $\tau_1, \dots, \tau_N$  in  $\mathbb{N}_0$ , and  $\nu$  in  $\mathbb{N}$  such that

$$s = \bigoplus_{k=1}^N (\Delta^{\tau_k} \gamma^\nu)^* f_k \gamma^{n_k}$$

The following notations are introduced:

$$\begin{aligned} m &= \max \left( 0, \min_{1 \leq k \leq N} (n_k - n) \right) \text{ and } M = \max_{1 \leq k \leq N} (0, n_k - n) \\ Y_f &= \bigwedge \{x \in \bar{\mathbb{N}}_{\max} \mid f(x) > \varepsilon\} \text{ and } Z_f = \bigwedge \{x \in \bar{\mathbb{N}}_{\max} \mid f(x) = \top\} \\ Y_k &= \bigwedge \{x \in \bar{\mathbb{N}}_{\max} \mid f_k(x) > \varepsilon\} \text{ and } Z_k = \bigwedge \{x \in \bar{\mathbb{N}}_{\max} \mid f_k(x) = \top\} \end{aligned}$$

Then,

$$((f\gamma^n) \downarrow_+ s)(l) = \begin{cases} \varepsilon & \text{if } l < m \\ f \downarrow_+ \left( \bigoplus_{k=1}^N \Delta^{l + \frac{l+n-n_k}{\nu} \lfloor \tau_k \rfloor} f_k \right) & \text{if } l \geq M \end{cases}$$

In the following, four cases are distinguished.

**First Case:**  $\sigma(s) = \sigma(f\gamma^n) = +\infty$ . According to Lem. 52,  $\tau_k = 0$ . This leads to

$$\forall l \geq M, \quad ((f\gamma^n) \downarrow_+ s)(l) = f \downarrow_+ \tilde{f} \text{ with } \tilde{f} = \bigoplus_{k=1}^N f_k$$

Therefore,  $(f\gamma^n) \downarrow_+ s = \bigoplus_{l=m}^M ((f\gamma^n) \downarrow_+ s)(l) \gamma^l$  is a periodic series. Furthermore,

$$f \downarrow_+ \tilde{f} = \text{Pr}_+ \left( \text{Pr}^{\mathcal{R}} \left( f^\# \circ \tilde{f} \right) \right) \leq f^\# \circ \tilde{f}$$

As  $f$  is a non-zero quasi-causal mapping,

$$\forall x \in \mathbb{N}_0, \quad \left( f \downarrow_+ \tilde{f} \right)(x) \leq f^\# \left( \tilde{f}(x) \right) \leq Y_f \oplus 1 \tilde{f}(x)$$

As  $\sigma(s) = +\infty$ ,  $\tilde{f}(x) \neq x$  for all  $x \in \mathbb{N}_0$ . Therefore, for all  $x \in \mathbb{N}_0$ ,  $\left( f \downarrow_+ \tilde{f} \right)(x) \neq \top$ . Consequently,  $(f\gamma^n) \downarrow_+ s$  is either equal to  $\varepsilon$  or  $\sigma((f\gamma^n) \downarrow_+ s) = +\infty = \sigma(s)$ .

**Second Case:**  $\sigma(s) > 0$  and  $\sigma(f\gamma^n) = 0$ . As  $\sigma(s) > 0$ , for all  $l \in \mathbb{Z}$  and  $x \in \mathbb{N}_0$ ,  $s(l)(x) \neq \top$ . Furthermore,  $\sigma(f\gamma^n) = 0$  implies  $Z_f \in \mathbb{N}_0$ . Then, if  $x \neq \top$ ,  $f^\#(x) \leq Z_f \neq 1$ . This leads to

$$\forall l \in \mathbb{Z}, \forall x \in \mathbb{N}_0, \quad ((f\gamma^n) \downarrow_+ s)(l)(x) \leq f^\#(s(l+n)(x)) \leq Z_f \neq 1$$

As  $((f\gamma^n) \downarrow_+ s)(l)$  is a quasi-causal mapping,  $((f\gamma^n) \downarrow_+ s)(l) = \varepsilon$ . Thus,  $(f\gamma^n) \downarrow_+ s = \varepsilon$  and  $(f\gamma^n) \downarrow_+ s$  is a periodic series.

**Third Case:**  $\sigma(s) = \sigma(f\gamma^n) = 0$ . As  $\sigma(f\gamma^n) = 0$ ,  $Z_f$  belongs to  $\mathbb{N}_0$ . According to Lem. 21,

$$\begin{aligned} \forall l \geq M, \quad ((f\gamma^n) \downarrow_+ s)(l) &= \text{Pr}_+(f \downarrow s(l+n)) \\ &= \text{Pr}_+\left(\bigoplus_{k=1}^N f \downarrow \left(\Delta^{l+\frac{n-n_k}{v}} \downarrow_{\tau_k} f_k\right)\right) \end{aligned}$$

We associate a parameter  $L_k$  in  $\mathbb{N}_0$  with each mapping  $f \downarrow \left(\Delta^{l+\frac{n-n_k}{v}} \downarrow_{\tau_k} f_k\right)$ .

If  $\tau_k = 0$ , then  $L_k = M$  and

$$\forall l \geq L_k, \quad f \downarrow \left(\Delta^{l+\frac{n-n_k}{v}} \downarrow_{\tau_k} f_k\right) = f \downarrow f_k$$

If  $\tau_k > 0$ , there exists  $L_k \geq M$  such that

$$\tau_k \downarrow_{\frac{L_k+n-n_k}{v}} f_k(Y_k) \geq f(Z_f \neq 1)$$

Then,

$$\forall l \geq L_k, \forall x \in \mathbb{N}_0, \quad f^\# \left( \tau_k \downarrow_{\frac{l+n-n_k}{v}} f_k(x) \right) = \begin{cases} f^\#(\varepsilon) & \text{if } x < Y_k \\ Z_f \neq 1 & \text{if } Z_k > x \geq Y_k \\ \top & \text{if } x \geq Z_k \end{cases}$$

As  $f \downarrow \left(\Delta^{l+\frac{n-n_k}{v}} \downarrow_{\tau_k} f_k\right) = \text{Pr}^{\mathcal{R}} \left( f^\# \circ \Delta^{l+\frac{n-n_k}{v}} \downarrow_{\tau_k} f_k \right)$ ,  $f \downarrow \left(\Delta^{l+\frac{n-n_k}{v}} \downarrow_{\tau_k} f_k\right)$  is defined by

$$\forall l \geq L_k, \forall x \in \mathbb{N}_0, \quad \left( f \downarrow \left(\Delta^{l+\frac{n-n_k}{v}} \downarrow_{\tau_k} f_k\right) \right)(x) = \begin{cases} \varepsilon & \text{if } x = \varepsilon f^\#(\varepsilon) \text{ if } e \leq x < Y_k \\ Z_f \neq 1 & \text{if } Z_k > x \geq Y_k \\ \top & \text{if } x \geq Z_k \end{cases}$$

In both cases (*i.e.*,  $\tau_k = 0$  or  $\tau_k > 0$ ),  $f \downarrow \left(\Delta^{l+\frac{n-n_k}{v}} \downarrow_{\tau_k} f_k\right)$  does not depend on  $l$  for  $l \geq L_k$ . Therefore,

$$\forall l \geq L_k, \quad f \downarrow \left(\Delta^{l+\frac{n-n_k}{v}} \downarrow_{\tau_k} f_k\right) = f \downarrow \left(\Delta^{L_k+\frac{n-n_k}{v}} \downarrow_{\tau_k} f_k\right)$$

Consequently,

$$(f\gamma^n) \downarrow_+ s = \bigoplus_{l=m}^L ((f\gamma^n) \downarrow_+ s)(l) \gamma^l \text{ with } L = \max_{1 \leq k \leq N} L_k$$

Hence,  $(f\gamma^n) \downarrow_+ s$  is a periodic series. Furthermore, as  $\sigma(s) = 0$ , there exists  $X \in \mathbb{N}_0$  such that  $s(L+n)(X) = \top$ . Then,

$$((f\gamma^n) \downarrow_+ s)(L)(X) = f^\#(s(L+n)(X)) = f^\#(\top) = \top$$



Therefore,  $\forall x \geq X$ ,  $((f\gamma^n) \downarrow s)(L)(x) \geq x$ . Consequently,

$$((f\gamma^n) \downarrow_+ s)(L)(X) = ((f\gamma^n) \downarrow s)(L)(X) = \top$$

Thus,  $\sigma((f\gamma^n) \downarrow_+ s) = 0$ .

**Fourth Case:**  $\sigma(s) \neq +\infty$  and  $\sigma(f\gamma^n) = +\infty$ . Let  $\mathcal{K} = \{k | \tau_k > 0\}$  and  $\mathcal{K}_0 = \{k | \tau_k = 0\}$ .

$$\forall l \geq M, \quad s(l+n) = \tilde{f} \oplus \bigoplus_{k \in \mathcal{K}} \Delta^{\lfloor \frac{l+n-n_k}{v} \rfloor \tau_k} f_k \text{ with } \tilde{f} = \bigoplus_{k \in \mathcal{K}_0} f_k$$

Then, according to Lem. 20 and Lem. 21,

$$\begin{aligned} \forall l \geq M, \quad ((f\gamma^n) \downarrow s)(L) &= f \downarrow \tilde{f} \oplus \bigoplus_{k \in \mathcal{K}} f \downarrow \left( \Delta^{\lfloor \frac{l+n-n_k}{v} \rfloor \tau_k} f_k \right) \\ &= \text{Pr}^{\mathcal{R}} \left( f^\# \circ \tilde{f} \right) \oplus \bigoplus_{k \in \mathcal{K}} \text{Pr}^{\mathcal{R}} \left( f^\# \circ \Delta^{\lfloor \frac{l+n-n_k}{v} \rfloor \tau_k} f_k \right) \end{aligned}$$

For  $k \in \mathcal{K}$ ,

$$\left( f^\# \circ \Delta^{\lfloor \frac{l+n-n_k}{v} \rfloor \tau_k} f_k \right)(x) = \begin{cases} f^\#(\varepsilon) & \text{if } x < Y_k \\ f^\# \left( \tau_k^{\lfloor \frac{l+n-n_k}{v} \rfloor} f_k(x) \right) & \text{if } x \geq Y_k \end{cases}$$

Then,  $f^\# \circ \Delta^{\lfloor \frac{l+n-n_k}{v} \rfloor \tau_k} f_k = f_\varepsilon \oplus f_{k,l}$  with

$$\forall x \in \overline{\mathbb{N}}_{\max}, \quad f_\varepsilon(x) = f^\#(\varepsilon) \text{ and } f_{k,l}(x) = \begin{cases} \varepsilon & \text{if } x < Y_k \\ f^\# \left( \tau_k^{\lfloor \frac{l+n-n_k}{v} \rfloor} f_k(x) \right) & \text{if } x \geq Y_k \end{cases}$$

This leads to, according to Lem. 19,

$$\forall l \geq M, \quad ((f\gamma^n) \downarrow s)(L) = \text{Pr}^{\mathcal{R}} \left( f^\# \circ \tilde{f} \oplus f_\varepsilon \right) \oplus \bigoplus_{k \in \mathcal{K}} \text{Pr}^{\mathcal{R}} (f_{k,l})$$

Note that  $f_{k,l}(\varepsilon) = \varepsilon$  and  $f_{k,l}$  is isotone. Furthermore,

$$\forall x \in \mathbb{N}_0, \quad \tau_k^{\lfloor \frac{l+n-n_k}{v} \rfloor} f_k(x) < f(R) \text{ with } R \in \mathbb{N}_0$$

is absurd, as  $\sigma(f\gamma^n) = +\infty$  and  $f_k$  is a non-zero quasi-causal mapping. Then, for all  $R \in \mathbb{N}_0$ , there exists  $x \in \mathbb{N}_0$  such that  $f_{k,l}(x) \geq R$ . Then,  $\bigoplus_{n \in \mathbb{N}} f_{k,l}(n) = \top = f_{k,l}(\top)$ . Consequently, according to Lem. 16,  $f_{k,l}$  is residuated. Hence,

$$\forall l \geq M, \quad ((f\gamma^n) \downarrow s)(L) = \text{Pr}^{\mathcal{R}} \left( f^\# \otimes \tilde{f} \oplus f_\varepsilon \right) \oplus \bigoplus_{k \in \mathcal{K}} f_{k,l}$$

Moreover, as  $f$  (resp.  $f_k$ ) is periodic with respect to  $X$  (resp.  $X_k$ ) and  $\omega$  (resp.  $\omega_k$ ), there exists  $L_1 \geq M$  such that

$$\forall k \in \mathcal{K}, \forall x \geq Y_k, \quad \tau_k^{\lfloor \frac{L_1+n-n_k}{v} \rfloor} f_k(x) \geq f(x)$$

Then, for  $l \geq L_1$ ,  $f_{k,l}$  is quasi-causal. Therefore,

$$\begin{aligned} \forall l \geq L_1, \quad ((f\gamma^n) \downarrow_{+s})(l) &= \text{Pr}_+(((f\gamma^n) \downarrow_s)(l)) \\ &= \text{Pr}_+ \left( \text{Pr}^{\mathcal{R}} \left( f^\# \circ \tilde{f} \oplus f_\varepsilon \right) \oplus \bigoplus_{k \in \mathcal{K}} f_{k,l} \right) \\ &= \text{Pr}_+ \left( \text{Pr}^{\mathcal{R}} \left( f^\# \circ \tilde{f} \oplus f_\varepsilon \right) \oplus \bigoplus_{k \in \mathcal{K}} f_{k,L_1} \oplus \bigoplus_{k \in \mathcal{K}} f_{k,l} \right) \\ &= \text{Pr}_+ \left( \text{Pr}^{\mathcal{R}} \left( f^\# \circ \tilde{f} \oplus f_\varepsilon \right) \oplus \bigoplus_{k \in \mathcal{K}} f_{k,L_1} \right) \oplus \bigoplus_{k \in \mathcal{K}} f_{k,l} \\ &= ((f\gamma^n) \downarrow_{+s})(L_1) \oplus \bigoplus_{k \in \mathcal{K}} f_{k,l} \end{aligned}$$

Consequently,

$$(f\gamma^n) \downarrow_{+s} = \bigoplus_{l=m}^{L_1} ((f\gamma^n) \downarrow_{+s})(l) \gamma^l \oplus \bigoplus_{k \in \mathcal{K}} \bigoplus_{l=L_1}^{+\infty} f_{k,l} \gamma^l$$

Furthermore, there exists  $L \geq L_1$  such that

$$\forall k \in \mathcal{K}, \quad \tau_k^{\lfloor \frac{L+n-n_k}{v} \rfloor} f_k(Y_k) \geq f(X)$$

Then, for  $x \in \mathbb{N}_0$  and  $l \geq L$ , if  $x < Y_k$ ,  $f_{k,l+\omega v}(x) = \varepsilon$  and, if  $x \geq Y_k$ , according to Lem. 30,

$$\begin{aligned} f_{k,l+\omega v}(x) &= f^\# \left( \tau_k^\omega \tau_k^{\lfloor \frac{l+n-n_k}{v} \rfloor} f_k(x) \right) \\ &= \tau_k^\omega f_{k,l}(x) \end{aligned}$$

Hence,  $f_{k,l+\omega v} = \Delta^{\omega \tau_k} f_{k,l}$  for  $l \geq L$ . Thus,

$$(f\gamma^n) \downarrow_{+s} = \bigoplus_{l=m}^L ((f\gamma^n) \downarrow_{+s})(l) \gamma^l \oplus \bigoplus_{k \in \mathcal{K}} (\Delta^{\omega \tau_k} \gamma^{\omega v})^* \left( \bigoplus_{l=0}^{\omega v-1} f_{k,L+l} \gamma^{L+l} \right)$$

According to Prop. 21, for  $l \geq L$ ,  $f_{k,l}$  is a periodic (with respect to  $X \oplus X_k$  and  $\text{lcm}(\omega, \omega_k)$ ) mapping. Thus,  $(f\gamma^n) \downarrow_{+s}$  is a periodic series. Furthermore, if  $\sigma(s) = 0$ , a reasoning

similar to the third case leads to  $\sigma((f\gamma^n) \downarrow_+ s) = 0$ . Otherwise,  $\mathcal{K}$  is not empty. For  $l \in \mathbb{N}_0$  with  $m \leq l \leq L$ ,

$$\forall x \in \overline{\mathbb{N}}_{\max}, \quad ((f\gamma^n) \downarrow_+ s)(l)(x) \leq \bigoplus_{k=1}^N Y_k \oplus 1s(l+n)(x)$$

and, for  $l \in \mathbb{N}_0$  with  $0 \leq l < \omega v$ ,

$$\forall x \in \overline{\mathbb{N}}_{\max}, \quad f_{k, L+l}(x) \leq Y_k \oplus 1\tau_k^{\lfloor \frac{L+l+n-n_k}{v} \rfloor} f_k(x)$$

Then, the values of the previous mappings for  $x \neq \top$  are different from  $\top$ . Furthermore, the mappings  $f_{k, L+l}$  are, by definition, non-zero. Consequently, according to Lem. 52,

$$\sigma((f\gamma^n) \downarrow_+ s) = \min_{k \in \mathcal{K}} \frac{v}{\tau_k} = \sigma(s)$$

□

**Lemma 55.** *Let  $s$  be a quasi-causal periodic series in  $\mathcal{F}_{\overline{\mathbb{N}}_{\max}, \gamma}[\gamma]$  and let  $v, \tau \in \mathbb{N}$ . Series  $(\Delta^\tau \gamma^v)^* \downarrow_+ s$  is periodic. Furthermore,*

- if  $s = \varepsilon$  or  $\sigma(s) > \sigma((\Delta^\tau \gamma^v)^*)$  then  $(\Delta^\tau \gamma^v)^* \downarrow_+ s = \varepsilon$
- if  $\sigma(s) \leq \sigma((\Delta^\tau \gamma^v)^*)$  then  $\sigma((\Delta^\tau \gamma^v)^* \downarrow_+ s) = \sigma(s)$

*Proof.* The particular case  $s = \varepsilon$  is considered. As  $(\Delta^\tau \gamma^v)^* \downarrow_+ s \leq e \downarrow_+ s \leq s$ ,  $(\Delta^\tau \gamma^v)^* \downarrow_+ s = \varepsilon$ . Hence, series  $(\Delta^\tau \gamma^v)^* \downarrow_+ s$  is periodic.

From now on, we assume that  $s \neq \varepsilon$ . Then, according to Prop. 27, there exist  $N \in \mathbb{N}$ , non-zero quasi-causal periodic mappings  $f_1, \dots, f_N$  in  $\mathcal{F}_{\overline{\mathbb{N}}_{\max}}$ ,  $n_1, \dots, n_N$  in  $\mathbb{N}_0$ ,  $\tau_1, \dots, \tau_N$  in  $\mathbb{N}_0$ , and  $v_1$  in  $\mathbb{N}$  such that

$$s = \bigoplus_{k=1}^N (\Delta^{\tau_k} \gamma^{v_1})^* f_k \gamma^{n_k}$$

According to (2.3),

$$(\Delta^\tau \gamma^v)^* \downarrow_+ s = \bigwedge_{j \geq 0} (\Delta^{j\tau} \gamma^{jv}) \downarrow_+ s$$

Then,

$$\forall l \in \mathbb{Z}, \quad ((\Delta^\tau \gamma^v)^* \downarrow_+ s)(l) = \bigwedge_{j \geq 0} \Delta^{j\tau} \downarrow_+ s(l + jv)$$

The following notations are introduced:

$$m = \min_{1 \leq k \leq N} n_k \text{ and } M = \max_{1 \leq k \leq N} n_k$$

If  $l < m$ ,  $((\Delta^\tau \gamma^\nu)^* \downarrow_+ s)(l) \leq s(l) = \varepsilon$ . This leads to  $((\Delta^\tau \gamma^\nu)^* \downarrow_+ s)(l) = \varepsilon$ . Otherwise,

$$((\Delta^\tau \gamma^\nu)^* \downarrow_+ s)(l) = \bigwedge_{R > j \geq 0} \Delta^{j\tau} \downarrow_+ s(l + j\nu) \wedge \bigwedge_{j \geq R} \Delta^{j\tau} \downarrow_+ \left( \bigoplus_{k=1}^N \Delta^{\lfloor \frac{l+j\nu-n_k}{\nu_1} \rfloor \tau_k} f_k \right)$$

with  $R = \lceil \frac{M-m}{\nu} \rceil$ . The set  $\mathcal{K}$  is defined by

$$\mathcal{K} = \left\{ k \mid \exists x \in \mathbb{N}_0, f_k(x) = \top \text{ or } \frac{\nu}{\tau} \geq \frac{\nu_1}{\tau_k} \right\}$$

In the following, two cases are distinguished.

**First Case:**  $\sigma(s) > \sigma((\Delta^\tau \gamma^\nu)^*)$  (or equivalently  $\mathcal{K} = \emptyset$ ). For  $l \geq m$ ,

$$\begin{aligned} \bigwedge_{j \geq R} \Delta^{j\tau} \downarrow_+ \left( \bigoplus_{k=1}^N \Delta^{\lfloor \frac{l+j\nu-n_k}{\nu_1} \rfloor \tau_k} f_k \right) &= \bigwedge_{j \geq R} \text{Pr}_+ \left( \bigoplus_{k=1}^N \Delta^{j\tau} \downarrow_+ \left( \Delta^{\lfloor \frac{l+j\nu-n_k}{\nu_1} \rfloor \tau_k} f_k \right) \right) \\ &\leq \bigwedge_{j \geq R} \left( \bigoplus_{k=1}^N \Delta^{j\tau} \downarrow_+ \left( \Delta^{\lfloor \frac{l+j\nu-n_k}{\nu_1} \rfloor \tau_k} f_k \right) \right) \end{aligned}$$

For  $l \geq m$  and  $x \in \mathbb{N}_0$ ,

$$\begin{aligned} \left( \Delta^{j\tau} \downarrow_+ \left( \Delta^{\lfloor \frac{l+j\nu-n_k}{\nu_1} \rfloor \tau_k} f_k \right) \right)(x) &= \left( \Delta^{j\tau} \right)^\# \left( \tau_k^{\lfloor \frac{l+j\nu-n_k}{\nu_1} \rfloor} f_k(x) \right) \\ &= \left( \tau_k^{\lfloor \frac{l+j\nu-n_k}{\nu_1} \rfloor} f_k(x) \right) \not\leq \tau^j \end{aligned}$$

To show that  $(\Delta^\tau \gamma^\nu)^* \downarrow_+ s = \varepsilon$ , it is sufficient to show that, for all  $l \geq m$  and for all  $x$  in  $\mathbb{N}_0$ , there exists  $j \geq R$  such that

$$\forall k, \quad \tau_k^{\lfloor \frac{l+j\nu-n_k}{\nu_1} \rfloor} f_k(x) < \tau^j$$

It is sufficient to show that, for all  $l \geq m$  and for all  $x \in \mathbb{N}_0$ , there exists  $L \geq \lceil \frac{R}{\nu_1} \rceil$  such that

$$\forall k, \quad \tau_k^{L\nu + \lfloor \frac{l-n_k}{\nu_1} \rfloor} f_k(x) < \tau^{L\nu_1}$$

Let us denote  $\mathcal{K}_x = \{k \mid f_k(x) \neq \varepsilon\}$ . If  $\mathcal{K}_x = \emptyset$ , the previous equation holds for all  $j \geq R$ . Otherwise, as  $f_k(x) \neq \top$ , the previous equation is equivalent in the standard algebra to

$$\begin{aligned} \forall k \in \mathcal{K}_x, \quad L\nu\tau_k + \lfloor \frac{l-n_k}{\nu_1} \rfloor \tau_k + f_k(x) &< L\nu_1\tau \\ \Leftrightarrow \forall k \in \mathcal{K}_x, \quad L(\nu_1\tau - \nu\tau_k) &> \lfloor \frac{l-n_k}{\nu_1} \rfloor \tau_k + f_k(x) \end{aligned}$$

As  $\mathcal{K} = \emptyset$ ,  $\nu_1\tau - \nu\tau_k > 0$ . Then, the previous equation is equivalent to

$$L \geq \tilde{L} = \max_{k \in \mathcal{K}_x} \left( \left\lfloor \frac{\lfloor \frac{l-n_k}{\nu_1} \rfloor \tau_k + f_k(x)}{\nu_1\tau - \nu\tau_k} \right\rfloor + 1, \left\lfloor \frac{R}{\nu_1} \right\rfloor \right)$$

This inequality proves the existence of a suitable parameter  $L$ . Hence, for  $l \geq m$ ,  $((\Delta^\tau \gamma^\nu)^* \downarrow_+ s)(l) = \varepsilon$ . Thus,  $(\Delta^\tau \gamma^\nu)^* \downarrow_+ s = \varepsilon$  is a periodic series.

**Second Case:**  $\sigma(s) \leq \sigma((\Delta^\tau \gamma^\nu)^*)$  (or equivalently  $\mathcal{K} \neq \emptyset$ ). Let  $Y$  be defined by

$$Y = \bigwedge \left\{ x \in \overline{\mathbb{N}}_{\max} \mid \bigoplus_{k \in \mathcal{K}} f_k(x) > \varepsilon \right\}$$

Let us define the quasi-causal periodic series  $\tilde{s}$  by

$$\tilde{s} = \bigoplus_{k=1}^N (\Delta^{\tau_k} \gamma^{\nu_1})^* \tilde{f}_k \gamma^{n_k} \text{ with } \tilde{f}_k(x) = \begin{cases} \varepsilon & \text{if } x < Y \\ f_k(x) & \text{if } x \geq Y \end{cases}$$

Clearly,  $\sigma(s) = \sigma(\tilde{s})$ . In the following, it is shown that  $(\Delta^\tau \gamma^\nu)^* \downarrow_+ s = (\Delta^\tau \gamma^\nu)^* \downarrow_+ \tilde{s}$ . A sufficient condition is to show that  $(\Delta^\tau \gamma^\nu)^* \downarrow_+ s = (\Delta^\tau \gamma^\nu)^* \downarrow_+ \tilde{s}$ .

For  $l < m$ ,  $((\Delta^\tau \gamma^\nu)^* \downarrow_+ s)(l) = \varepsilon = ((\Delta^\tau \gamma^\nu)^* \downarrow_+ \tilde{s})(l)$ .

For  $l \geq m$  and  $x < Y$ , a reasoning similar to the first case (i.e.,  $\mathcal{K} = \emptyset$ ) leads to  $((\Delta^\tau \gamma^\nu)^* \downarrow_+ s)(l)(x) = \varepsilon$ . Furthermore,

$$((\Delta^\tau \gamma^\nu)^* \downarrow_+ \tilde{s})(l)(x) \leq \tilde{s}(l)(x) = \varepsilon$$

Then,  $((\Delta^\tau \gamma^\nu)^* \downarrow_+ \tilde{s})(l)(x)$  is also equal to  $\varepsilon$ .

For  $l \geq m$  and  $x \geq Y$ ,

$$\begin{aligned} ((\Delta^\tau \gamma^\nu)^* \downarrow_+ s)(l)(x) &= \bigwedge_{j \geq 0} \left( \Delta^{j\tau} \right)^\# (s(l + j\nu)(x)) \\ &= \bigwedge_{j \geq 0} \left( \Delta^{j\tau} \right)^\# (\tilde{s}(l + j\nu)(x)) \\ &= ((\Delta^\tau \gamma^\nu)^* \downarrow_+ \tilde{s})(l)(x) \end{aligned}$$

Hence,  $(\Delta^\tau \gamma^\nu)^* \downarrow_+ s = (\Delta^\tau \gamma^\nu)^* \downarrow_+ \tilde{s}$ . Next the periodicity of  $(\Delta^\tau \gamma^\nu)^* \downarrow_+ \tilde{s}$  is investigated. As before, if  $l \geq m$ ,

$$((\Delta^\tau \gamma^\nu)^* \downarrow_+ \tilde{s})(l) = \bigwedge_{R > j \geq 0} \Delta^{j\tau} \downarrow_+ \tilde{s}(l + j\nu) \wedge \bigwedge_{j \geq R} \Delta^{j\tau} \downarrow_+ \left( \bigoplus_{k=1}^N \Delta^{\lfloor \frac{l+j\nu-n_k}{\nu_1} \rfloor \tau_k} \tilde{f}_k \right)$$

By definition of  $\mathcal{K}$ , there exists  $J \geq R$  such that

$$\forall j \geq J, \quad \bigoplus_{k=1}^N \Delta^{\lfloor \frac{l+jv-n_k}{v_1} \rfloor \tau_k} \tilde{f}_k = \bigoplus_{k \in \mathcal{K}} \Delta^{\lfloor \frac{l+jv-n_k}{v_1} \rfloor \tau_k} \tilde{f}_k$$

Consequently, for  $l \geq m$ ,

$$\begin{aligned} ((\Delta^\tau \gamma^\nu)^* \wp_+ \tilde{s})(l) &= \bigwedge_{J > j \geq 0} \Delta^{j\tau} \wp_+ \tilde{s}(l+jv) \wedge \bigwedge_{j \geq J} \Delta^{j\tau} \wp_+ \left( \bigoplus_{k \in \mathcal{K}} \Delta^{\lfloor \frac{l+jv-n_k}{v_1} \rfloor \tau_k} \tilde{f}_k \right) \\ \Delta^{j\tau} \wp_+ \left( \bigoplus_{k \in \mathcal{K}} \Delta^{\lfloor \frac{l+jv-n_k}{v_1} \rfloor \tau_k} \tilde{f}_k \right) &= \text{Pr}_+ \left( \bigoplus_{k \in \mathcal{K}} \Delta^{j\tau} \wp \left( \Delta^{\lfloor \frac{l+jv-n_k}{v_1} \rfloor \tau_k} \tilde{f}_k \right) \right) \end{aligned}$$

Then,

$$\begin{aligned} \forall k \in \mathcal{K}, \quad \Delta^{(j+v_1)\tau} \wp \left( \Delta^{\lfloor \frac{l+(j+v_1)v-n_k}{v_1} \rfloor \tau_k} \tilde{f}_k \right) &= \Delta^{(j+v_1)\tau} \wp \left( \Delta^{v\tau_k} \Delta^{\lfloor \frac{l+jv-n_k}{v_1} \rfloor \tau_k} \tilde{f}_k \right) \\ &= \Delta^{j\tau} \wp \left( \Delta^{v\tau_k - v_1\tau} \Delta^{\lfloor \frac{l+jv-n_k}{v_1} \rfloor \tau_k} \tilde{f}_k \right) \end{aligned}$$

Hence, as  $\frac{\tau}{v} \leq \frac{\tau_k}{v_1}$  for  $k \in \mathcal{K}$ ,

$$\forall k \in \mathcal{K}, \quad \Delta^{(j+v_1)\tau} \wp \left( \Delta^{\lfloor \frac{l+(j+v_1)v-n_k}{v_1} \rfloor \tau_k} \tilde{f}_k \right) \geq \Delta^{j\tau} \wp \left( \Delta^{\lfloor \frac{l+jv-n_k}{v_1} \rfloor \tau_k} \tilde{f}_k \right)$$

Therefore,

$$\bigwedge_{j \geq J} \Delta^{j\tau} \wp_+ \left( \bigoplus_{k=1}^N \Delta^{\lfloor \frac{l+jv-n_k}{v_1} \rfloor \tau_k} \tilde{f}_k \right) = \bigwedge_{j=J}^{J+v_1-1} \Delta^{j\tau} \wp_+ \left( \bigoplus_{k=1}^N \Delta^{\lfloor \frac{l+jv-n_k}{v_1} \rfloor \tau_k} \tilde{f}_k \right)$$

Thus, for  $l \geq m$ ,

$$((\Delta^\tau \gamma^\nu)^* \wp_+ s)(l) = ((\Delta^\tau \gamma^\nu)^* \wp_+ \tilde{s})(l) = \bigwedge_{j=0}^{J+v_1-1} \left( (\Delta^{j\tau} \gamma^{j\nu}) \wp_+ \tilde{s} \right)(l)$$

Then,

$$(\gamma^\nu \Delta^\tau)^* \wp_+ s = \bigwedge_{j=0}^{J+v_1-1} \left( \Delta^{j\tau} \gamma^{j\nu} \right) \wp_+ \tilde{s}$$

Consequently, according to Lem. 54 and Prop. 29,  $(\Delta^\tau \gamma^\nu)^* \wp_+ s$  is a periodic series and

$$\sigma((\Delta^\tau \gamma^\nu)^* \wp_+ s) = \sigma(\tilde{s}) = \sigma(s)$$

□

**Proposition 44** (Left-division of quasi-causal periodic series). *Let  $s_1, s_2$  be two quasi-causal periodic series in  $\mathcal{F}_{\overline{\mathbb{N}}_{\max}, \gamma}[\gamma]$ .  $s_1 \downarrow_+ s_2$  is a periodic series. If  $s_1$  and  $s_2$  are different from  $\varepsilon$ ,*

- *if  $\sigma(s_1) < \sigma(s_2)$ , then  $s_1 \downarrow_+ s_2 = \varepsilon$ .*
- *if  $\sigma(s_1) = \sigma(s_2) = +\infty$ , then  $s_1 \downarrow_+ s_2$  is either equal to  $\varepsilon$  or  $\sigma(s_1 \downarrow_+ s_2) = +\infty$ .*
- *if  $\sigma(s_2) \neq +\infty$  and  $\sigma(s_1) \geq \sigma(s_2)$ , then  $\sigma(s_1 \downarrow_+ s_2) = \sigma(s_2)$ .*

*Proof.* If  $s_1 = \varepsilon$ ,  $s_1 \downarrow_+ s_2 = \top$  is a periodic series. Otherwise, according to Prop. 27, there exist  $N \in \mathbb{N}$ , non-zero quasi-causal periodic mappings  $f_1, \dots, f_N, n_1, \dots, n_N$  in  $\mathbb{N}_0$ ,  $\tau_1, \dots, \tau_N$  in  $\mathbb{N}_0$ , and  $\nu$  in  $\mathbb{N}$  such that

$$s_1 = \bigoplus_{k=1}^N (\Delta^{\tau_k} \gamma^\nu)^* f_k \gamma^{n_k}$$

According to (2.3) and (2.5),

$$s_1 \downarrow_+ s_2 = \bigwedge_{k=1}^N (f_k \gamma^{n_k}) \downarrow_+ ((\Delta^{\tau_k} \gamma^\nu)^* \downarrow_+ s_2)$$

Then, using Lem. 54, Lem. 55, and Prop. 29,  $s_1 \downarrow_+ s_2$  is a periodic series. To determine the throughput of  $s_1 \downarrow_+ s_2$ , three cases are distinguished.

**First Case:**  $\sigma(s_1) < \sigma(s_2)$ .

There exists  $k$  such that  $\sigma((\Delta^{\tau_k} \gamma^\nu)^*) < \sigma(s_2)$  or  $\sigma(f_k \gamma^{n_k}) < \sigma(s_2)$ . Consequently, according to Lem. 54 and Lem. 55,  $s_1 \downarrow_+ s_2 = \varepsilon$ .

**Second Case:**  $\sigma(s_1) = \sigma(s_2) = +\infty$ .

For all  $k$ ,  $\tau_k = 0$ . Then,

$$s_1 \downarrow_+ s_2 = \bigwedge_{k=1}^N (f_k \gamma^{n_k}) \downarrow_+ s_2$$

Thus, according to Lem. 54,  $s_1 \downarrow_+ s_2$  is either equal to  $\varepsilon$  or  $\sigma(s_1 \downarrow_+ s_2) = +\infty$ .

**Third Case:**  $\sigma(s_2) \neq +\infty$  and  $\sigma(s_1) \geq \sigma(s_2)$ .

Then, according to Lem. 54 and Lem. 55, for all  $k$ ,

$$\sigma((f_k \gamma^{n_k}) \downarrow_+ ((\Delta^{\tau_k} \gamma^\nu)^* \downarrow_+ s_2)) = \sigma(s_2)$$

Thus,  $\sigma(s_1 \downarrow_+ s_2) = \sigma(s_2)$  □

### A.1.5. Kleene Star of Causal Periodic Series

#### Causal Polynomial

In the following, we prove that the Kleene star of a causal polynomial with periodic coefficients is a periodic series.

**Lemma 56.** *Let  $p$  be a non-zero causal polynomial in  $\mathcal{F}_{\mathbb{N}_{\max}, \gamma}[[\gamma]]$  such that all its coefficients are periodic with respect to  $X_p \in \mathbb{N}_0$  and  $\omega_p \in \mathbb{N}$ . Then,*

$$\forall R \in \mathbb{N}, \quad \bigoplus_{l=0}^{X_p+R+1} p^l = \bigoplus_{l=0}^{X_p} p^l \oplus \left( \bigoplus_{l=0}^R \tilde{p}^l \right) p^{X_p+1}$$

where

$$\forall l \in \mathbb{Z}, \quad \tilde{p}(l)(x) = \begin{cases} \varepsilon & \text{if } x < X_p \\ p(l)(x) & \text{if } x \geq X_p \end{cases}$$

*Proof.* The canonical representative of  $p$  is denoted

$$p = \bigoplus_{i=1}^N f_i \gamma^{n_i}$$

with  $N$  in  $\mathbb{N}$ , non-zero causal periodic mappings  $f_1, \dots, f_N$  in  $\mathcal{F}_{\mathbb{N}_{\max}, \gamma}[[\gamma]]$ , and  $n_1, \dots, n_N$  in  $\mathbb{N}_0$ . By assumption,  $f_k$  is periodic with respect to  $X_p$  in  $\mathbb{N}_0$  and  $\omega_p$  in  $\mathbb{N}$ . Furthermore,

$$\tilde{p} = \bigoplus_{i=1}^N \tilde{f}_i \gamma^{n_i} \text{ with } \tilde{f}_i(x) = \begin{cases} \varepsilon & \text{if } x < X_p \\ f_i(x) & \text{if } x \geq X_p \end{cases}$$

This lemma is shown by induction on  $R$ . First, the initial step (*i.e.*,  $R = 1$ ) is proved. The aim is to show that

$$\bigoplus_{l=0}^{X_p+2} p^l = \bigoplus_{l=0}^{X_p+1} p^l \oplus \tilde{p} p^{X_p+1}$$

By definition,  $p \geq \tilde{p}$ . Therefore,

$$\bigoplus_{l=0}^{X_p+2} p^l \geq \bigoplus_{l=0}^{X_p+1} p^l \oplus \tilde{p} p^{X_p+1}$$

Conversely,

$$p^{X_p+2} \leq \bigoplus_{l=0}^{X_p+1} p^l \oplus \tilde{p} p^{X_p+1} \Rightarrow \bigoplus_{l=0}^{X_p+2} p^l \leq \bigoplus_{l=0}^{X_p+1} p^l \oplus \tilde{p} p^{X_p+1}$$



Therefore, it is sufficient to show that

$$\forall x \in \bar{\mathbb{N}}_{\max}, \quad \psi \left( p^{X_p+2} \right) (x) \leq \psi \left( \bigoplus_{l=0}^{X_p+1} p^l \oplus \tilde{p} p^{X_p+1} \right) (x)$$

As

$$\forall x \in \bar{\mathbb{N}}_{\max}, \quad \psi \left( p^{X_p+2} \right) (x) = \bigoplus_{i_1=1}^N \dots \bigoplus_{i_{X_p+2}=1}^N \left( \bigotimes_{j=1}^{X_p+2} f_{i_j} \right) (x) \gamma^{\sum_{j=1}^{X_p+2} n_{i_j}}$$

it is sufficient to show that

$$\forall i_1, \dots, i_{X_p+2}, \forall x \in \bar{\mathbb{N}}_{\max}, \quad \left( \bigotimes_{j=1}^{X_p+2} f_{i_j} \right) (x) \gamma^{\sum_{j=1}^{X_p+2} n_{i_j}} \leq \psi \left( \bigoplus_{l=0}^{X_p+1} p^l \oplus \tilde{p} p^{X_p+1} \right) (x)$$

Depending on the values of  $\left( \bigotimes_{j=2}^{X_p+2} f_{i_j} \right) (x)$ , several cases are distinguished.

If  $\left( \bigotimes_{j=2}^{X_p+2} f_{i_j} \right) (x) = \varepsilon$ , then

$$\left( \bigotimes_{j=1}^{X_p+2} f_{i_j} \right) (x) \gamma^{\sum_{j=1}^{X_p+2} n_{i_j}} = \varepsilon \leq \psi \left( \bigoplus_{l=0}^{X_p+1} p^l \oplus \tilde{p} p^{X_p+1} \right) (x)$$

If  $\left( \bigotimes_{j=2}^{X_p+2} f_{i_j} \right) (x) \geq X_p$ , then, according to the definition of  $\tilde{p}$ ,

$$\left( \bigotimes_{j=1}^{X_p+2} f_{i_j} \right) (x) = \left( \tilde{f}_{i_1} \otimes \bigotimes_{j=2}^{X_p+2} f_{i_j} \right) (x)$$

Therefore,

$$\left( \bigotimes_{j=1}^{X_p+2} f_{i_j} \right) (x) \gamma^{\sum_{j=1}^{X_p+2} n_{i_j}} \leq \psi \left( \tilde{p} p^{X_p+1} \right) (x) \leq \psi \left( \bigoplus_{l=0}^{X_p+1} p^l \oplus \tilde{p} p^{X_p+1} \right) (x)$$

Otherwise,  $e \leq \left( \bigotimes_{j=2}^{X_p+2} f_{i_j} \right) (x) < X_p$ . As  $f_{i_j}$  is non-zero and causal,  $f_{i_j} \geq \text{Id}$ . Then,

$$e \leq f_{i_{X_p+2}}(x) \leq \dots \leq \left( \bigotimes_{j=2}^{X_p+2} f_{i_j} \right) (x) < X_p$$

Therefore, there exists  $K$  with  $2 \leq K \leq X_p+2$  such that

$$\left( \bigotimes_{j=2}^{X_p+2} f_{i_j} \right) (x) = \left( \bigotimes_{j=2, j \neq K}^{X_p+2} f_{i_j} \right) (x)$$

Besides, due to the causality of  $p$ ,  $n_{i_k} \geq 0$ . Therefore,

$$\begin{aligned} \left( \bigotimes_{j=1}^{X_p+2} f_{i_j} \right) (x) \gamma^{\sum_{j=1}^{X_p+2} n_{i_j}} &\leq \left( \bigotimes_{j=1, j \neq K}^{X_p+2} f_{i_j} \right) (x) \gamma^{\sum_{j=1, j \neq K}^{X_p+2} n_{i_j}} \\ &\leq \psi \left( p^{X_p+1} \right) (x) \\ &\leq \psi \left( \bigoplus_{l=0}^{X_p+1} p^l \oplus \tilde{p} p^{X_p+1} \right) (x) \end{aligned}$$

Henceforth, the result holds for  $R = 1$ . Second, the inductive step is proved. It is assumed that, for a given  $R \in \mathbb{N}$ ,

$$\bigoplus_{l=0}^{X_p+R+1} p^l = \bigoplus_{l=0}^{X_p} p^l \oplus \left( \bigoplus_{l=0}^R \tilde{p}^l \right) p^{X_p+1}$$

Next, the equality is checked for  $R + 1$ .

$$\begin{aligned} \bigoplus_{l=0}^{X_p+R+2} p^l &= e \oplus p \left( \bigoplus_{l=0}^{X_p+R+1} p^l \right) \\ &= \bigoplus_{l=0}^{X_p+2} p^l \oplus \left( \bigoplus_{l=1}^R p \tilde{p}^l \right) p^{X_p+1} \\ &= \bigoplus_{l=0}^{X_p+1} p^l \oplus \tilde{p} p^{X_p+1} \oplus \left( \bigoplus_{l=1}^R p \tilde{p}^l \right) p^{X_p+1} \text{ using the results for } R = 1 \end{aligned}$$

Furthermore, due to the definition of  $\tilde{p}$ ,  $p \tilde{p} = \tilde{p}^2$ . Thus,

$$\bigoplus_{l=0}^{X_p+R+2} p^l = \bigoplus_{l=0}^{X_p} p^l \oplus \left( \bigoplus_{l=0}^{R+1} \tilde{p}^l \right) p^{X_p+1}$$

This achieves the induction. □

**Lemma 57.** *Let  $p$  be a non-zero causal polynomial in  $\mathcal{F}_{\mathbb{N}_{\max}, \gamma}[\gamma]$  such that all its coefficients are periodic with respect to  $X_p \in \mathbb{N}_0$  and  $\omega_p \in \mathbb{N}$ . Then,*

$$p^* = \bigoplus_{l=0}^{X_p} p^l \oplus \tilde{p}^* p^{X_p+1}$$

where

$$\forall l \in \mathbb{Z}, \quad \tilde{p}^*(l)(x) = \begin{cases} \varepsilon & \text{if } x < X_p \\ p(l)(x) & \text{if } x \geq X_p \end{cases}$$

*Proof.* It is a direct consequence of the previous lemma by considering  $R$  approaching  $+\infty$ .  $\square$

In the next lemma, the periodicity of  $p^*$  is investigated where  $p$  is a non-zero quasi-causal polynomial with periodic coefficients fulfilling some additional properties.

**Lemma 58.** *Let  $p$  be a non-zero quasi-causal polynomial in  $\mathcal{F}_{\overline{\mathbb{N}}_{\max}, \gamma}[\gamma]$  such that all its coefficients are periodic with respect to  $X_p$  in  $\mathbb{N}_0$  and  $\omega_p$  in  $\mathbb{N}$  and*

$$\forall l \in \mathbb{Z}, \forall x < X_p, \quad p(l)(x) = \varepsilon$$

*Then,  $p^*$  is a periodic series in  $\mathcal{F}_{\overline{\mathbb{N}}_{\max}, \gamma}[\gamma]$ .*

*Proof.* The canonical representative of  $p$  is denoted

$$p = \bigoplus_{i=1}^N f_i \gamma^{n_i}$$

with  $N$  in  $\mathbb{N}$ , non-zero causal periodic mappings  $f_1, \dots, f_N$  in  $\mathcal{F}_{\overline{\mathbb{N}}_{\max}, \gamma}[\gamma]$ , and  $n_1 < \dots < n_N$  in  $\mathbb{N}_0$ . By assumption,  $f_k$  is periodic with respect to  $X_p$  in  $\mathbb{N}_0$  and  $\omega_p$  in  $\mathbb{N}$  and  $f_k(x) = \varepsilon$  for  $x < X_p$ . Obviously,

$$\forall k \in \mathbb{N}, \quad p^k = \bigoplus_{i_1=1}^N \dots \bigoplus_{i_k=1}^N \bigotimes_{j=1}^k f_{i_j} \gamma^{n_{i_j}}$$

Then,

$$\forall k \in \mathbb{N}, \forall x \in \overline{\mathbb{N}}_{\max}, \quad \psi(p^k)(x) = \bigoplus_{i_1=1}^N \dots \bigoplus_{i_k=1}^N \left( \bigotimes_{j=1}^k f_{i_j} \right) (x) \gamma^{\sum_{j=1}^k n_{i_j}}$$

For a mapping  $f$  in  $\mathcal{F}_{\overline{\mathbb{N}}_{\max}}$ , the set of fixed points of  $f$ , denoted  $\text{fix}(f)$ , is defined by  $\text{fix}(f) = \{x \in \overline{\mathbb{N}}_{\max} \mid f(x) = x\}$ . In the following, two cases are distinguished depending on the sets of fixed points of the coefficients of  $p$ .

**First Case:**  $\bigcap_{i=1}^N \text{fix}(f_i) \neq \{\varepsilon, \top\}$ . There exists one fixed point  $b$  shared by all mappings  $f_i$  such that  $X_p \leq b < \omega_p X_p$ . Due to the periodicity of  $f_i$ ,  $\omega_p^j b$  with  $j \in \mathbb{N}_0$  is also a fixed point.

$$\psi(p^{\omega_p+1})(x) = \bigoplus_{i_1=1}^N \dots \bigoplus_{i_{\omega_p+1}=1}^N \left( \bigotimes_{j=1}^{\omega_p+1} f_{i_j} \right) (x) \gamma^{\sum_{j=1}^{\omega_p+1} n_{i_j}}$$

In the following, we prove that  $p^{\omega_p} \geq p^{\omega_p+1}$ , or equivalently for all  $x \in \overline{\mathbb{N}}_{\max}$ ,  $\psi(p^{\omega_p})(x) \geq \psi(p^{\omega_p+1})(x)$ . For  $x < X_p$ ,

$$\psi(p^{\omega_p})(x) = \varepsilon = \psi(p^{\omega_p+1})(x)$$

For  $x \geq X_p$ , we reason on the monomials composing  $\psi(p^{\omega_p+1})(x)$ . If  $x = \top$ , as  $n_{i_{\omega_p+1}} \geq 0$ ,

$$\left( \bigotimes_{j=1}^{\omega_p+1} f_{i_j} \right) (\top) \gamma^{\sum_{j=1}^{\omega_p+1} n_{i_j}} = \top \gamma^{\sum_{j=1}^{\omega_p+1} n_{i_j}} \leq \top \gamma^{\sum_{j=1}^{\omega_p} n_{i_j}} \leq \psi(p^{\omega_p})(\top)$$

Otherwise, B is defined as the least fixed point greater than or equal to  $x$ . Clearly,  $B < \omega_p x$ . Then, as  $f_i(x) \geq x$  for  $x \geq X_p$ ,

$$x \leq f_{i_{\omega_p+1}}(x) \leq \dots \leq \left( \bigotimes_{j=1}^{\omega_p+1} f_{i_j} \right) (x) \leq B < \omega_p x$$

Therefore, there exists K such that

$$\left( \bigotimes_{j=1}^{\omega_p+1} f_{i_j} \right) (x) = \left( \bigotimes_{j=1, j \neq K}^{\omega_p+1} f_{i_j} \right) (x)$$

As  $n_{i_K} \geq 0$ ,

$$\left( \bigotimes_{j=1}^{\omega_p+1} f_{i_j} \right) (x) \gamma^{\sum_{j=1}^{\omega_p+1} n_{i_j}} \leq \left( \bigotimes_{j=1, j \neq K}^{\omega_p+1} f_{i_j} \right) (x) \gamma^{\sum_{j=1, j \neq K}^{\omega_p+1} n_{i_j}} \leq \psi(p^{\omega_p})(x)$$

Consequently,  $p^{\omega_p+1} \leq p^{\omega_p}$ . Thus,  $p^*$  is a periodic series equal to  $\bigoplus_{l=0}^{\omega_p} p^l$ .

**Second Case:**  $\bigcap_{i=1}^N \text{fix}(f_i) = \{\varepsilon, \top\}$ . As  $f_1 < \dots < f_N$ ,  $\text{fix}(f_N) = \{\varepsilon, \top\}$ .

First, we show that the calculation of  $p^*$  reduces to the calculation of  $\tilde{p}^*$  where  $\tilde{p}$  is a non-zero quasi-causal polynomial in  $\mathcal{F}_{\overline{\mathbb{N}}_{\max}, \gamma}[\gamma]$  such that all its coefficients are periodic with respect to  $X_p$  in  $\mathbb{N}_0$  and  $\omega_p$  in  $\mathbb{N}$  and

$$\begin{cases} \forall l \in \mathbb{Z}, \forall x < X_p, & \tilde{p}(l)(x) = \varepsilon \\ \forall l \geq \text{val}(\tilde{p}), & \text{fix}(\tilde{p}(l)) = \{\varepsilon, \top\} \end{cases}$$

Let us consider a sequence  $(p_m)_{m \geq 0}$  of non-zero quasi-causal polynomials  $p_m$  such that all their coefficients are periodic with respect to  $X_p$  in  $\mathbb{N}_0$  and  $\omega_p$  in  $\mathbb{N}$  and

$$\forall l \in \mathbb{Z}, \forall x < X_p, \quad p_m(l)(x) = \varepsilon$$

The canonical representative of  $p_m$  is denoted  $p_m = \bigoplus_{i=1}^{N_m} f_{m,i} \gamma^{n_{m,i}}$  where mappings  $f_{m,i}$  are, by assumption, periodic with respect to  $X_p$  and  $\omega_p$ . The sequence  $(p_m)_{m \geq 0}$  is defined by the following algorithm:

1. Initialization: set  $p_0$  to  $p$  and set  $m$  to 0
2. While  $\text{fix}(f_{m,1}) \neq \{\varepsilon, \top\}$ , set  $p_{m+1}$  to  $(f_{m,1}\gamma^{n_{m,1}})^* \left( \bigoplus_{i=2}^{N_m} f_{m,i}\gamma^{n_{m,i}} \right)$  and set  $m$  to  $m+1$

As  $\text{fix}(f_{m,1}) \neq \{\varepsilon, \top\}$ ,  $(f_{m,1}\gamma^{n_{m,1}})^*$  is a polynomial with periodic coefficients. Therefore,  $p_{m+1}$  is a polynomial with periodic coefficients. According to (2.8),

$$p_m^* = p_{m+1}^* (f_{m,1}\gamma^{n_{m,1}})^*$$

Then, as  $\text{fix}(f_{m,1}) \neq \{\varepsilon, \top\}$ , to show the periodicity of  $p_m^*$ , it is sufficient to prove the periodicity of  $p_{m+1}^*$ . Therefore, to show that the calculation of  $p^*$  boils down to the calculation of  $\tilde{p}^*$ , it is sufficient to check that the previous algorithm stops after a finite number of steps (*i.e.*, there exists  $M \in \mathbb{N}_0$  such that  $\text{fix}(f_{M,1}) = \{\varepsilon, \top\}$ ), as  $\text{fix}(f_{M,1}) = \{\varepsilon, \top\}$  implies  $\text{fix}(f_{M,i}) = \{\varepsilon, \top\}$  for all  $i$ . Obvious properties of the sequence  $(p_m)_{m \geq 0}$  are

$$\forall m \in \mathbb{N}_0, \quad \text{val}(p_{m+1}) = n_{m+1,1} = n_{m,2} > n_{m,1} = \text{val}(p_m) \tag{A.1}$$

$$\forall m \in \mathbb{N}_0, \forall l < m, \quad f_{m,1} = p_m(n_{m,1}) \geq p_l(n_{m,1}) \tag{A.2}$$

According to (A.1), there exists  $M \in \mathbb{N}_0$  such that  $\text{val}(p_M) \geq n_{0, N_0}$ . Then, according to (A.2),  $f_{M,1} \geq p_0(\text{val}(p_M)) = f_{0, N_0}$ . As  $\text{fix}(f_{0, N_0})$  is equal to  $\{\varepsilon, \top\}$ ,  $\text{fix}(f_{M,1})$  is equal to  $\{\varepsilon, \top\}$ . Therefore, in the following, we only consider a non-zero quasi-causal polynomial  $p$  such that all its coefficients are periodic with respect to  $X_p$  in  $\mathbb{N}_0$  and  $\omega_p$  in  $\mathbb{N}$  and

$$\begin{cases} \forall l \in \mathbb{Z}, \forall x < X_p, & p(l)(x) = \varepsilon \\ \forall l \geq \text{val}(p), & \text{fix}(p(l)) = \{\varepsilon, \top\} \end{cases}$$

Second, some work is done using condition  $\text{fix}(f_i) = \{\varepsilon, \top\}$  to consider only a subclass of polynomials.

$$p^* = (p^{\omega_p})^* \left( \bigoplus_{l=0}^{\omega_p-1} p^l \right)$$

with

$$\begin{aligned} p^{\omega_p} &= \bigoplus_{i_1=1}^N \dots \bigoplus_{i_{\omega_p}=1}^N \bigotimes_{j=1}^{\omega_p} f_{i_j} \gamma^{n_{i_j}} \\ &= \bigoplus_{i=1}^{N_{\omega_p}} f_{\omega_p, i} \gamma^{n_{\omega_p, i}} \end{aligned}$$

where the last expression denotes the canonical representative of  $p^{\omega_p}$ . Clearly,

$$\text{val}(p^{\omega_p}) = n_{\omega_p, 1} = \omega_p n_1 \text{ and } f_{\omega_p, 1} = f_1^{\omega_p}$$

As  $f_1$  does not admit any fixed point,  $f_1^{\omega_p}(X_p) \geq \omega_p X_p$ . Furthermore, as  $f_{\omega_p, i+1} \geq f_{\omega_p, i}$ ,  $f_{\omega_p, i}(X_p) \geq \omega_p X_p$ . Therefore, in the following, we investigate the periodicity of  $p^*$  with a non-zero quasi-causal polynomial  $p$  such that all its coefficients are periodic with respect to  $X_p$  in  $\mathbb{N}_0$  and  $\omega_p$  in  $\mathbb{N}$  and

$$\begin{cases} \forall l \in \mathbb{Z}, \forall x < X_p, & p(l)(x) = \varepsilon \\ \forall l \geq \text{val}(p), & p(l)(X_p) \geq \omega_p X_p \end{cases}$$

The canonical representative of  $p$  is denoted  $p = \bigoplus_{i=1}^N f_i \gamma^{n_i}$  with  $N$  in  $\mathbb{N}$ , non-zero causal periodic mappings  $f_1, \dots, f_N$  in  $\mathcal{F}_{\overline{\mathbb{N}}_{\max}, \gamma}[\gamma]$ , and  $n_1 < \dots < n_N$  in  $\mathbb{N}_0$ . By assumption,  $f_k$  is periodic with respect to  $X_p$  in  $\mathbb{N}_0$  and  $\omega_p$  in  $\mathbb{N}$ ,  $f_k(x) = \varepsilon$  for  $x < X_p$ , and  $f_k(X_p) \geq \omega_p X_p$ .

Finally, the periodicity of  $p^*$  is obtained by analogy with [15]. If  $f_N(X_p) = \top$ , then,  $\forall l \geq n_N$ ,  $p^*(l) = f_N$  and, for  $l < n_N$ , the coefficients of  $p^*$  can be obtained by developing the expression. Then,  $p^*$  is a polynomial with periodic coefficients:  $p^*$  is a periodic series. Otherwise,  $f_i(X_p)$  belongs to  $\mathbb{N}_0$  for all  $i$ . It is easy to check that

$$f_i = \bigoplus_{k=0}^{\omega_p-1} \Delta^{f_i(kX_p)} \nabla \left( \Delta^{k+X_p} \right)^\#$$

where  $\nabla$  is a periodic mapping in  $\mathcal{F}_{\overline{\mathbb{N}}_{\max}}$  defined by

$$\nabla(x) = \begin{cases} \varepsilon & \text{if } x = \varepsilon \\ \lfloor \frac{x}{\omega_p} \rfloor^{\omega_p} & \text{if } x \geq e \end{cases}$$

Therefore, polynomial  $p$  can be written under the form

$$p = \bigoplus_{k=1}^M \Delta^{m_k} \nabla \left( \Delta^{r_k} \right)^\# \gamma^{n_k}$$

Then,

$$\forall k \in \mathbb{N}, \quad p^k = \bigoplus_{i_1=1}^M \dots \bigoplus_{i_k=1}^M \bigotimes_{j=1}^k \Delta^{m_{i_j}} \nabla \left( \Delta^{r_{i_j}} \right)^\# \gamma^{n_{i_j}}$$

By noticing that

$$\forall j, k \in \mathbb{N}_0, \quad \left( \Delta^k \right)^\# \Delta^j = \Delta^{j-k} \text{ if } j \geq k \text{ and } \nabla \Delta^j \nabla = \Delta^{\lfloor \frac{j}{\omega_p} \rfloor^{\omega_p}} \nabla$$

we obtain

$$\forall k \geq 2, \quad \bigotimes_{j=1}^k \Delta^{m_{i_j}} \nabla \left( \Delta^{r_{i_j}} \right)^\# = \Delta^{m_{i_1}} \Delta^k \nabla \left( \Delta^{r_{i_1}} \right)^\#$$

with

$$K = \sum_{j=1}^{k-1} \lfloor \frac{m_{i_{j+1}} - r_{i_j}}{\omega_p} \rfloor \omega_p$$

The condition  $m_{i_{j+1}} \geq r_{i_j}$  is ensured by the hypothesis  $f_i(X_p) \geq \omega_p X_p$ . Then, a matrix  $\phi$  in  $\mathcal{F}_{\Delta, \gamma}[\gamma]^{M \times M}$  is defined by

$$\phi_{ij} = \Delta \lfloor \frac{m_j - r_i}{\omega_p} \rfloor \omega_p \gamma^{n_i}$$

This leads to

$$\begin{aligned} \forall k \geq 3, \quad p^k &= \bigoplus_{i_1=1}^M \dots \bigoplus_{i_k=1}^M \bigotimes_{j=1}^k \Delta^{m_{i_j}} \nabla (\Delta^{r_{i_j}})^{\#} \gamma^{n_{i_j}} \\ &= \bigoplus_{i_1=1}^M \dots \bigoplus_{i_k=1}^M \Delta^{m_{i_1}} \left( \bigotimes_{j=1}^{k-1} \Delta \lfloor \frac{m_{i_{j+1}} - r_{i_j}}{\omega_p} \rfloor \omega_p \gamma^{n_{i_j}} \right) \nabla (\Delta^{r_{i_k}})^{\#} \gamma^{n_{i_k}} \\ &= \bigoplus_{i_1=1}^M \dots \bigoplus_{i_k=1}^M \Delta^{m_{i_1}} \left( \bigotimes_{j=1}^{k-1} \phi_{i_j i_{j+1}} \right) \nabla (\Delta^{r_{i_k}})^{\#} \gamma^{n_{i_k}} \\ &= \bigoplus_{i_1=1}^M \bigoplus_{i_k=1}^M \Delta^{m_{i_1}} \left( \bigoplus_{i_2=1}^M \dots \bigoplus_{i_{k-1}=1}^M \bigotimes_{j=1}^{k-1} \phi_{i_j i_{j+1}} \right) \nabla (\Delta^{r_{i_k}})^{\#} \gamma^{n_{i_k}} \\ &= \bigoplus_{I=1}^M \bigoplus_{J=1}^M \Delta^{m_I} \left( \phi^{k-1} \right)_{IJ} \nabla (\Delta^{r_J})^{\#} \gamma^{n_J} \end{aligned}$$

Therefore,

$$\begin{aligned} p^* &= e \oplus p \oplus p^2 \oplus \bigoplus_{k=3}^{+\infty} p^k \\ &= e \oplus p \oplus p^2 \oplus \bigoplus_{k=3}^{+\infty} \bigoplus_{I=1}^M \bigoplus_{J=1}^M \Delta^{m_I} \left( \phi^{k-1} \right)_{IJ} \nabla (\Delta^{r_J})^{\#} \gamma^{n_J} \\ &= e \oplus p \oplus p^2 \oplus \bigoplus_{I=1}^M \bigoplus_{J=1}^M \Delta^{m_I} \left( \phi^2 \phi^* \right)_{IJ} \nabla (\Delta^{r_J})^{\#} \gamma^{n_J} \end{aligned}$$

As  $\phi^*$  is periodic,  $p^*$  is a periodic series. □

**Proposition 45.** *The Kleene star of a causal polynomial with periodic coefficients is a periodic series.*

*Proof.* Let  $p$  be a causal polynomial in  $\mathcal{F}_{\mathbb{N}_{\max}, \gamma}[[\gamma]]$  with periodic coefficients. If  $p = \varepsilon$ , then  $p^* = e$  is a periodic series. Otherwise, we can find  $X_p \in \mathbb{N}_0$  and  $\omega_p \in \mathbb{N}$  such that all coefficients of  $p$  are periodic with respect to  $X_p$  and  $\omega_p$ . Then, according to Lem. 57,

$$p^* = \bigoplus_{l=0}^{X_p+1} p^l \oplus \tilde{p}^* p^{X_p+2}$$

where

$$\forall l \in \mathbb{Z}, \quad \tilde{p}(l)(x) = \begin{cases} \varepsilon & \text{if } x < X_p \\ p(l)(x) & \text{if } x \geq X_p \end{cases}$$

As  $\tilde{p}$  fulfills the condition of Lem. 58,  $\tilde{p}^*$  is a periodic series. Thus,  $p^*$  is a periodic series.  $\square$

### Causal Periodic Series

In the following, we prove that the Kleene star of a causal periodic series is a causal periodic series.

**Proposition 46.** *The Kleene star of a causal periodic series is a causal periodic series.*

*Proof.* Let  $s$  be a causal periodic series in  $\mathcal{F}_{\mathbb{N}_{\max}, \gamma}[[\gamma]]$  with the canonical representative:

$$s = p \oplus \bigoplus_{k=1}^N \left( \Delta^{\tau_k} \gamma^{\nu'} \right)^* q_k$$

Furthermore, we define  $X \in \mathbb{N}_0$  and  $\omega \in \mathbb{N}$  such that all coefficients of  $q_1, \dots, q_N$  and  $p$  are periodic with respect to  $X$  and  $\omega$ .

Series  $s^*$  is causal, as the dioid of causal series is a complete subdioid of  $\mathcal{F}_{\mathbb{N}_{\max}, \gamma}[[\gamma]]$ . It remains to show that  $s^*$  is periodic.

The proof is done by induction on  $N$ . The initial step  $N = 0$  corresponds to the polynomial case, which has been solved in Prop. 45. For the inductive step, it is assumed that the proposition holds for  $N - 1$  with  $N \in \mathbb{N}$ .

If  $\tau_N = 0$ ,  $s^*$  is a periodic series according to the induction hypothesis. If  $\tau_N > 0$ , there exists  $L \geq 0$  such that  $L\tau_N \geq X$ . Let us define  $\tau$  and  $\nu$  by  $\tau = \text{lcm}(\omega, \tau_N) = m\tau_N$ , and  $\nu = m\nu'$ . Then,  $s$  is rewritten using the parameters  $L$ ,  $\tau$ , and  $\nu$ .

$$s = s_1 \oplus \left( \Delta^{\tau} \gamma^{\nu} \right)^* q$$

with

$$s_1 = p \oplus \bigoplus_{l=0}^{L-1} \Delta^{l\tau_N} q_N \gamma^{l\nu'} \oplus \bigoplus_{k=1}^{N-1} \left( \Delta^{\tau_k} \gamma^{\nu'} \right)^* q_k$$

$$q = \bigoplus_{l=0}^{m-1} \Delta^{(L+1)\tau_N} q_N \gamma^{(L+1)\nu'}$$



According to (2.8),

$$s^* = (s_1^* (\Delta^\tau \gamma^\nu)^* q)^* s_1^*$$

Consider a series  $d$  in  $\{\varepsilon, e, s_1, \Delta^\tau \gamma^\nu\}^*$ . Series  $d$  is causal as  $s_1$  and  $\Delta^\tau \gamma^\nu$  are causal. Then,

$$\forall k \in \mathbb{Z}, \forall x \in \overline{\mathbb{N}}_{\max}, \quad (s_1 \Delta^\tau \gamma^\nu d q)(k)(x) = \bigoplus_{(i,j,l) \in S} (s_1(i) \Delta^\tau d(j) q(l))(x)$$

$$\text{where } S = \{(i, j, l) \in \mathbb{Z}^3 \mid i + j + l + \nu = k\}$$

By definition,  $q(l)(x)$  is either equal to  $\varepsilon$  or greater than or equal to  $L\tau_{\mathbb{N}}$ . Then, as  $d(j)$  is causal,  $(d(j) q(l))(x)$  is either equal to  $\varepsilon$  or greater than or equal to  $L\tau_{\mathbb{N}}$ . Due to the periodicity of  $s_1(i)$  and to the fact that  $\omega$  divides  $\tau$ ,

$$\bigoplus_{(i,j,l) \in S} s_1(i) \Delta^\tau d(j) q(l) = \bigoplus_{(i,j,l) \in S} \Delta^\tau s_1(i) d(j) q(l)$$

Therefore, for all series  $d$  in  $\{\varepsilon, e, s_1, \gamma^\nu \Delta^\tau\}^*$ ,  $s_1 \Delta^\tau \gamma^\nu d q = \Delta^\tau \gamma^\nu s_1 d q$ . Then, according to Lem. 3,

$$s_1^* (\Delta^\tau \gamma^\nu)^* q = (s_1 \oplus \Delta^\tau \gamma^\nu)^* q$$

Consequently, according to (2.9),

$$\begin{aligned} s^* &= ((s_1 \oplus \Delta^\tau \gamma^\nu)^* q)^* s_1^* \\ &= (e \oplus (s_1 \oplus \gamma^\nu \Delta^\tau \oplus q)^* q) s_1^* \end{aligned}$$

Using the induction hypothesis,  $s^*$  is a periodic series. □

## A.2. Calculation with Series in $\mathcal{F}_{\overline{\mathbb{N}}_{\max, \gamma}}^{\text{per}, c} [\gamma]$

### A.2.1. Sum of Series in $\mathcal{F}_{\overline{\mathbb{N}}_{\max, \gamma}}^{\text{per}, c} [\gamma]$

**Proposition 47** (Sum of series in  $\mathcal{F}_{\overline{\mathbb{N}}_{\max, \gamma}}^{\text{per}, c} [\gamma]$ ). *Let  $s_1$  and  $s_2$  be two series in  $\mathcal{F}_{\overline{\mathbb{N}}_{\max, \gamma}}^{\text{per}, c} [\gamma]$ .  $s_1 \oplus s_2$  belongs to  $\mathcal{F}_{\overline{\mathbb{N}}_{\max, \gamma}}^{\text{per}, c} [\gamma]$ . If  $s_1$  and  $s_2$  are different from  $\varepsilon$ , then*

$$\sigma(s_1 \oplus s_2) = \min(\sigma(s_1), \sigma(s_2))$$

*Proof.* According to Prop. 28, it remains to show that  $s_1 \oplus s_2$  belongs to  $\mathcal{F}_{\overline{\mathbb{N}}_{\max, \gamma}}^{\text{per}, c} [\gamma]$ . If  $s_1$  or  $s_2$  is equal to  $\varepsilon$ , then  $s_1 \oplus s_2$  obviously belongs to  $\mathcal{F}_{\overline{\mathbb{N}}_{\max, \gamma}}^{\text{per}, c} [\gamma]$ . Otherwise, according to

Lem. 34,

$$\begin{aligned}
 \psi(s_1 \oplus s_2)(e) &= \psi(s_1)(e) \oplus \psi(s_2)(e) \\
 \Rightarrow \sigma(\psi(s_1 \oplus s_2)(e)) &= \min(\sigma(\psi(s_1)(e)), \sigma(\psi(s_2)(e))) \\
 \Rightarrow \sigma(\psi(s_1 \oplus s_2)(e)) &= \min(\sigma(s_1), \sigma(s_2)) \\
 \Rightarrow \sigma(\psi(s_1 \oplus s_2)(e)) &= \sigma(s_1 \oplus s_2)
 \end{aligned}$$

□

### A.2.2. Greatest Lower Bound of Series in $\mathcal{F}_{\overline{\mathbb{N}}_{\max, \gamma}}^{\text{per}, c}[\llbracket \gamma \rrbracket]$

**Proposition 48** (Greatest lower bound of series in  $\mathcal{F}_{\overline{\mathbb{N}}_{\max, \gamma}}^{\text{per}, c}[\llbracket \gamma \rrbracket]$ ). *Let  $s_1$  and  $s_2$  be two series in  $\mathcal{F}_{\overline{\mathbb{N}}_{\max, \gamma}}^{\text{per}, c}[\llbracket \gamma \rrbracket]$ .  $s_1 \wedge s_2$  belongs to  $\mathcal{F}_{\overline{\mathbb{N}}_{\max, \gamma}}^{\text{per}, c}[\llbracket \gamma \rrbracket]$ . If  $s_1$  and  $s_2$  are different from  $\varepsilon$ , then*

$$\sigma(s_1 \wedge s_2) = \max(\sigma(s_1), \sigma(s_2))$$

*Proof.* According to Prop. 29, it remains to show that  $s_1 \wedge s_2$  belongs to  $\mathcal{F}_{\overline{\mathbb{N}}_{\max, \gamma}}^{\text{per}, c}[\llbracket \gamma \rrbracket]$ . If  $s_1$  or  $s_2$  is equal to  $\varepsilon$ , then  $s_1 \wedge s_2$  obviously belongs to  $\mathcal{F}_{\overline{\mathbb{N}}_{\max, \gamma}}^{\text{per}, c}[\llbracket \gamma \rrbracket]$ . Otherwise, according to Lem. 34,

$$\begin{aligned}
 \psi(s_1 \wedge s_2)(e) &= \psi(s_1)(e) \wedge \psi(s_2)(e) \\
 \Rightarrow \sigma(\psi(s_1 \wedge s_2)(e)) &= \max(\sigma(\psi(s_1)(e)), \sigma(\psi(s_2)(e))) \\
 \Rightarrow \sigma(\psi(s_1 \wedge s_2)(e)) &= \max(\sigma(s_1), \sigma(s_2)) \\
 \Rightarrow \sigma(\psi(s_1 \wedge s_2)(e)) &= \sigma(s_1 \wedge s_2)
 \end{aligned}$$

□

### A.2.3. Product of Series in $\mathcal{F}_{\overline{\mathbb{N}}_{\max, \gamma}}^{\text{per}, c}[\llbracket \gamma \rrbracket]$

**Proposition 49** (Product of series in  $\mathcal{F}_{\overline{\mathbb{N}}_{\max, \gamma}}^{\text{per}, c}[\llbracket \gamma \rrbracket]$ ). *Let  $s_1$  and  $s_2$  be two series in  $\mathcal{F}_{\overline{\mathbb{N}}_{\max, \gamma}}^{\text{per}, c}[\llbracket \gamma \rrbracket]$ .  $s_1 \otimes s_2$  belongs to  $\mathcal{F}_{\overline{\mathbb{N}}_{\max, \gamma}}^{\text{per}, c}[\llbracket \gamma \rrbracket]$ . If  $s_1$  and  $s_2$  are different from  $\varepsilon$ , then*

$$\sigma(s_1 \otimes s_2) = \min(\sigma(s_1), \sigma(s_2))$$

*Proof.* According to Prop. 30, it remains to show that  $s_1 \otimes s_2$  belongs to  $\mathcal{F}_{\overline{\mathbb{N}}_{\max, \gamma}}^{\text{per}, c}[\llbracket \gamma \rrbracket]$ . If  $s_1$  or  $s_2$  is equal to  $\varepsilon$ , then  $s_1 \otimes s_2$  obviously belongs to  $\mathcal{F}_{\overline{\mathbb{N}}_{\max, \gamma}}^{\text{per}, c}[\llbracket \gamma \rrbracket]$ . Otherwise, according to Lem. 34,

$$\psi(s_1 \otimes s_2)(e) = \bigoplus_{j \in \mathbb{Z}} \psi(s_1)(\psi(s_2)(e)(j)) \gamma^j$$

In the following, two cases are discussed depending on  $\sigma(s_2)$ .

**First Case:**  $\sigma(s_2) = 0$  or  $\sigma(s_2) = +\infty$ .

Series  $s_2$  is a polynomial with the canonical representative

$$s_2 = \bigoplus_{k=1}^N f_k \gamma^{n_k} \text{ with } n_1 < \dots < n_N$$

Then,

$$\psi(s_1 \otimes s_2)(e) = \bigoplus_{k=1}^N \psi(s_1)(f_k(e)) \gamma^{n_k}$$

This leads to

$$\begin{aligned} \sigma(\psi(s_1 \otimes s_2)(e)) &= \min_{1 \leq k \leq N} (\sigma(\psi(s_1)(f_k(e)))) \\ &= \begin{cases} \sigma(s_1) & \text{if } \sigma(s_2) = +\infty \\ 0 & \text{if } \sigma(s_2) = 0 \end{cases} \\ &= \min(\sigma(s_1), \sigma(s_2)) \\ &= \sigma(s_1 \otimes s_2) \end{aligned}$$

**Second Case:**  $0 < \sigma(s_2) < +\infty$ .

As  $s_1$  is a periodic series in  $\mathcal{F}_{\mathbb{N}_{\max}, \gamma}[\gamma]$ , there exist, according to Lem. 38,  $X \in \mathbb{N}_0$  and  $\omega \in \mathbb{N}$  such that

$$\forall x \geq X, \quad \psi(s_1)(\omega x) = \omega \psi(s_1)(x)$$

Furthermore, as  $\psi(s_2)(e)$  is a periodic series with  $\sigma(\psi(s_2)(e)) = \sigma(s_2)$ , there exist  $K, \tau, \nu$  in  $\mathbb{N}$  such that

$$\begin{cases} \psi(s_2)(e)(K) \geq X \\ \forall k \geq K, \quad \psi(s_2)(e)(k + \nu) = \tau \psi(s_2)(e)(k) \\ \frac{\nu}{\tau} = \sigma(s_2) \text{ and } \omega \text{ divides } \tau \end{cases}$$

Then,

$$\begin{aligned} \psi(s_1 \otimes s_2)(e) &= \bigoplus_{j \in \mathbb{Z}} \psi(s_1)(\psi(s_2)(e)(j)) \gamma^j \\ &= \bigoplus_{j < K} \psi(s_1)(\psi(s_2)(e)(j)) \gamma^j \\ &\quad \oplus (\tau \gamma^\nu)^* \left( \bigoplus_{k=0}^{\nu-1} \psi(s_1)(\psi(s_2)(e)(K+k)) \gamma^{K+k} \right) \end{aligned}$$

Thus,

$$\begin{aligned}\sigma(\psi(s_1 \otimes s_2)(e)) &= \min\left(\sigma(s_1), \frac{\nu}{\tau}\right) \\ &= \min(\sigma(s_1), \sigma(s_2)) \\ &= \sigma(s_1 \otimes s_2)\end{aligned}$$

□

#### A.2.4. Left-Division of Series in $\mathcal{F}_{\overline{\mathbb{N}}_{\max}, \gamma}^{\text{per}, c}[\Gamma]$

The set of causal series in  $\mathcal{F}_{\overline{\mathbb{N}}_{\max}, \gamma}[\Gamma]$  is a complete dioid. Therefore, the product is residuated. Series  $s_1 \downarrow_{+++} s_2$  is the greatest causal series  $s$  such that  $s_1 \otimes s \leq s_2$ . In the following, we investigate whether  $s_1 \downarrow_{+++} s_2$  belongs to  $\mathcal{F}_{\overline{\mathbb{N}}_{\max}, \gamma}^{\text{per}, c}[\Gamma]$  when  $s_1$  and  $s_2$  belong to  $\mathcal{F}_{\overline{\mathbb{N}}_{\max}, \gamma}^{\text{per}, c}[\Gamma]$ . The periodicity of  $s_1 \downarrow_{+++} s_2$  is ensured by Prop. 26 and Prop. 31. Next, two intermediate lemmas are proved.

**Lemma 59.** *Let  $s$  be a series in  $\mathcal{F}_{\overline{\mathbb{N}}_{\max}, \gamma}^{\text{per}, c}[\Gamma]$  and let  $f$  be a non-zero causal periodic mapping in  $\mathcal{F}_{\overline{\mathbb{N}}_{\max}}^{\text{per}, c}$ . For  $n \in \mathbb{N}_0$ ,  $(f\gamma^n) \downarrow_{+++} s$  is a series in  $\mathcal{F}_{\overline{\mathbb{N}}_{\max}, \gamma}^{\text{per}, c}[\Gamma]$ . Furthermore,*

- if  $s = \varepsilon$  or  $\sigma(f\gamma^n) < \sigma(s)$ , then  $(f\gamma^n) \downarrow_{+++} s = \varepsilon$ .
- if  $\sigma(f\gamma^n) = \sigma(s) = +\infty$ , then  $(f\gamma^n) \downarrow_{+++} s = \varepsilon$  or  $\sigma((f\gamma^n) \downarrow_{+++} s) = \sigma(s)$ .
- if  $\sigma(s) \neq +\infty$  and  $\sigma(f\gamma^n) \geq \sigma(s)$ , then  $\sigma((f\gamma^n) \downarrow_{+++} s) = \sigma(s)$ .

*Proof.* Series  $(f\gamma^n) \downarrow_{+++} s$  is causal by definition and periodic (see Prop. 26 and Prop. 31). Therefore, it remains to check the results on the throughput and that either  $(f\gamma^n) \downarrow_{+++} s = \varepsilon$  or

$$\sigma((f\gamma^n) \downarrow_{+++} s) = \sigma(\psi((f\gamma^n) \downarrow_{+++} s)(e))$$

According to (2.10),

$$\forall l \in \mathbb{Z}, \quad ((f\gamma^n) \downarrow_{+++} s)(l) = \begin{cases} \varepsilon & \text{if } l < 0 \\ f \downarrow_{+++} s(l+n) & \text{if } l \geq 0 \end{cases}$$

The remaining of the proof is divided in four cases.

**First case:**  $s = \varepsilon$  or  $\sigma(f\gamma^n) < \sigma(s)$ .

Obviously,  $(f\gamma^n) \downarrow_{+++} s \leq (f\gamma^n) \downarrow_{+} s$ . Then, according to Prop. 31,  $(f\gamma^n) \downarrow_{+++} s = \varepsilon$ .

**Second case:**  $\sigma(s) = \sigma(f\gamma^n) = +\infty$ .

The canonical representative of  $s$  is denoted

$$s = \bigoplus_{k=1}^N f_k \gamma^{n_k} \text{ with } n_1 < \dots < n_N$$

For  $l \geq M = \max(0, n_N - n)$ ,

$$((f\gamma^n) \downarrow_{++} s)(l) = f \downarrow_{++} f_N$$

Then,

$$(f\gamma^n) \downarrow_{++} s = \bigoplus_{l=0}^M ((f\gamma^n) \downarrow_{++} s)(l) \gamma^l$$

If  $f \downarrow_{++} f_N = \varepsilon$ , then  $(f\gamma^n) \downarrow_{++} s = \varepsilon$ . Otherwise, as  $f \downarrow_{++} f_N \leq f_N$  and  $f \downarrow_{++} f_N$  is a non-zero causal mapping,

$$\sigma((f\gamma^n) \downarrow_{++} s) = \sigma(\psi((f\gamma^n) \downarrow_{++} s)(e)) = +\infty$$

**Third case:**  $\sigma(s) = 0$ .

The canonical representative of  $s$  is denoted

$$s = \bigoplus_{k=1}^N f_k \gamma^{n_k} \text{ with } n_1 < \dots < n_N \text{ and } f_N = \top$$

For  $l \geq M = \max(0, n_N - n)$ ,

$$((f\gamma^n) \downarrow_{++} s)(l) = f \downarrow_{++} \top = \top$$

Then,

$$(f\gamma^n) \downarrow_{++} s = \bigoplus_{l=0}^{M-1} ((f\gamma^n) \downarrow_{++} s)(l) \gamma^l \oplus \top \gamma^M$$

Therefore,

$$\sigma((f\gamma^n) \downarrow_{++} s) = \sigma(\psi((f\gamma^n) \downarrow_{++} s)(e)) = 0$$

**Fourth case:**  $0 < \sigma(s) < +\infty$  and  $\sigma(f\gamma^n) = +\infty$ .

The canonical representative of  $s$  is denoted  $p \oplus (\Delta^{\tau\gamma^\nu})^* q$  with  $\tau, \nu$  in  $\mathbb{N}$  and causal polynomials  $p, q$  in  $\mathcal{F}_{\overline{\mathbb{N}}_{\max}, \gamma}[\gamma]$  with the canonical representatives

$$p = \bigoplus_{k=1}^{N_p} f_{p,k} \gamma^{n_{p,k}} \text{ and } q = \bigoplus_{k=1}^{N_q} f_{q,k} \gamma^{n_{q,k}}$$

Let us consider  $M = \max(0, n_{p, N_p} - n, n_{q, N_q} - n)$ .

$$\forall l \geq M, \quad s(l+n) = f_p \oplus \bigoplus_{k=1}^{N_q} \Delta^{l+\frac{n-n_{q,k}}{\nu}} \downarrow_{\tau} f_{q,k} \text{ with } f_p = \bigoplus_{k=1}^{N_p} f_{p,k}$$

Then, according to Lem. 20 and Lem. 21,

$$\begin{aligned} \forall l \geq M, \quad ((f\gamma^n) \downarrow_s)(l) &= f \downarrow_{f_p} \oplus \bigoplus_{k=1}^{N_q} f \downarrow_{\left( \Delta^{l+\frac{n-n_{q,k}}{\nu}} \downarrow_{\tau} f_{q,k} \right)} \\ &= \text{Pr}^{\mathcal{R}}(f^\# \otimes f_p) \oplus \bigoplus_{k=1}^{N_q} \text{Pr}^{\mathcal{R}}\left(f^\# \otimes \Delta^{l+\frac{n-n_{q,k}}{\nu}} \downarrow_{\tau} f_{q,k}\right) \\ &= \text{Pr}^{\mathcal{R}}(f^\# \otimes f_p) \oplus \bigoplus_{k=1}^{N_q} \text{Pr}^{\mathcal{R}}(f_{k,l}) \end{aligned}$$

with

$$\forall x \in \overline{\mathbb{N}}_{\max}, \quad f_{k,l}(x) = \begin{cases} \varepsilon & \text{if } x = \varepsilon \\ f^\# \left( \tau^{l+\frac{n-n_{q,k}}{\nu}} \downarrow_{\tau} f_{q,k}(x) \right) & \text{if } x \neq \varepsilon \end{cases}$$

$f_{k,l}(\varepsilon) = \varepsilon$  and  $f_{k,l}$  is isotone. Furthermore,

$$\forall x \in \overline{\mathbb{N}}_{\max}, \quad f^\# \left( \tau^{l+\frac{n-n_{q,k}}{\nu}} \downarrow_{\tau} f_{q,k}(x) \right) \geq f^\#(f(x)) \geq x$$

Then, as  $\sigma(f\gamma^n) = +\infty$ ,  $\bigoplus_{n \in \mathbb{N}} f_{k,l}(n) = \top = f_{k,l}(\top)$ . Consequently, according to Lem. 16,  $f_{k,l}$  is residuated. Hence,

$$\forall l \geq M, \quad ((f\gamma^n) \downarrow_s)(l) = \text{Pr}^{\mathcal{R}}(f^\# \otimes f_p) \oplus \bigoplus_{k=1}^{N_q} f_{k,l}$$

Moreover, as mapping  $f$  (resp.  $f_k$ ) is causal and periodic with respect to  $X$  (resp.  $X_k$ ) and  $\omega$  (resp.  $\omega_k$ ), there exists  $L_1 \geq M$  such that

$$\forall k, \quad \tau^{L_1+\frac{n-n_{q,k}}{\nu}} \downarrow_{\tau} f_{q,k} \geq f$$

Then, for  $l \geq L_1$ ,  $f_{k,l}$  is causal. Therefore,

$$\begin{aligned} \forall l \geq L_1, \quad ((f\gamma^n) \downarrow_{+++} s) (l) &= \text{Pr}_{++} (((f\gamma^n) \downarrow s) (l)) \\ &= \text{Pr}_{++} \left( \text{Pr}^{\mathcal{R}} (f^\# \otimes f_p) \oplus \bigoplus_{k=1}^{N_q} f_{k,l} \right) \\ &= \text{Pr}^{\mathcal{R}} (f^\# \otimes f_p) \oplus \bigoplus_{k=1}^{N_q} f_{k,l} \end{aligned}$$

Consequently,

$$(f\gamma^n) \downarrow_{+++} s = \bigoplus_{l=0}^{L_1} ((f\gamma^n) \downarrow_{+++} s) (l) \gamma^l \oplus \bigoplus_{k=1}^{N_q} \bigoplus_{l=L_1}^{+\infty} f_{k,l} \gamma^l$$

Furthermore, there exists  $L \geq L_1$  such that

$$\forall k, \quad \tau^l \tau^{\lfloor \frac{L+n-n_{q,k}}{v} \rfloor} f_{q,k} (e) \geq f(X)$$

Then, for  $x \in \bar{\mathbb{N}}_0$  and  $l \geq L$ , according to Lem. 30,

$$\begin{aligned} f_{k,l+\omega v} (x) &= f^\# \left( \tau^\omega \tau^{\lfloor \frac{L+n-n_{q,k}}{v} \rfloor} f_{q,k} (x) \right) \\ &= \tau^\omega f_{k,l} (x) \end{aligned}$$

Hence,  $f_{k,l+\omega v} = \Delta^{\omega\tau} f_{k,l}$  for  $l \geq L$ . Thus,

$$(f\gamma^n) \downarrow_{+++} s = \bigoplus_{l=0}^L ((f\gamma^n) \downarrow_{+++} s) (l) \gamma^l \oplus (\Delta^{\omega\tau} \gamma^{\omega v})^* \left( \bigoplus_{k=1}^{N_q} \bigoplus_{l=0}^{\omega v-1} f_{k,L+l} \gamma^{L+l} \right)$$

For  $l \in \bar{\mathbb{N}}_0$  with  $l \leq L$ ,

$$\forall x \in \bar{\mathbb{N}}_{\max}, \quad ((f\gamma^n) \downarrow_{+++} s) (l) (x) \leq 1s(l+n)(x)$$

and, for  $0 \leq l < \omega v$ ,

$$\forall x \in \bar{\mathbb{N}}_{\max}, \quad f_{k,L+l} (x) \leq 1\tau^{\lfloor \frac{L+l+n-n_{q,k}}{v} \rfloor} f_{q,k} (x)$$

Then, the values of the previous mappings for  $x \neq \top$  are different from  $\top$ . Furthermore, the mappings  $f_{k,L+l}$  are, by definition, non-zero and causal. Consequently,

$$\sigma((f\gamma^n) \downarrow_{+++} s) = \sigma(\psi((f\gamma^n) \downarrow_{+++} s)(e)) = \frac{v}{\tau} = \sigma(s)$$

□

**Lemma 60.** *Let  $s$  be a series in  $\mathcal{F}_{\mathbb{N}_{\max, \gamma}}^{\text{per}, c}[\gamma]$  and let  $\nu, \tau \in \mathbb{N}$ . Series  $(\Delta^\tau \gamma^\nu)^* \downarrow_{++} s$  belongs to  $\mathcal{F}_{\mathbb{N}_{\max, \gamma}}^{\text{per}, c}[\gamma]$ . Furthermore,*

- *if  $s = \varepsilon$  or  $\sigma(s) > \sigma((\Delta^\tau \gamma^\nu)^*)$ , then  $(\Delta^\tau \gamma^\nu)^* \downarrow_{++} s = \varepsilon$ .*
- *if  $\sigma(s) \leq \sigma((\Delta^\tau \gamma^\nu)^*)$ , then  $\sigma((\Delta^\tau \gamma^\nu)^* \downarrow_{++} s) = \sigma(s)$ .*

*Proof.* Series  $(\Delta^\tau \gamma^\nu)^* \downarrow_{++} s$  is causal by definition and periodic (see Prop. 26 and Prop. 31). Therefore, it remains to check the results on the throughput and that either  $(\Delta^\tau \gamma^\nu)^* \downarrow_{++} s = \varepsilon$  or

$$\sigma((\Delta^\tau \gamma^\nu)^* \downarrow_{++} s) = \sigma(\psi((\Delta^\tau \gamma^\nu)^* \downarrow_{++} s)(e))$$

The remaining of the proof is divided in three cases.

**First case:**  $s = \varepsilon$  or  $\sigma(s) > \sigma((\Delta^\tau \gamma^\nu)^*)$ .

Obviously,  $(\Delta^\tau \gamma^\nu)^* \downarrow_{++} s \leq (\Delta^\tau \gamma^\nu)^* \downarrow_{+} s$ . Then, according to Prop. 31,  $(\Delta^\tau \gamma^\nu)^* \downarrow_{++} s = \varepsilon$ .

**Second case:**  $\sigma(s) = 0$ .

The canonical representative of  $s$  is denoted

$$s = \bigoplus_{k=1}^N f_k \gamma^{n_k} \text{ with } n_1 < \dots < n_N \text{ and } f_N = \top$$

According to (2.3),

$$(\Delta^\tau \gamma^\nu)^* \downarrow_{++} s = \bigwedge_{j \geq 0} (\Delta^{j\tau} \gamma^{j\nu}) \downarrow_{++} s$$

Duo to causality,  $((\Delta^\tau \gamma^\nu)^* \downarrow_{++} s)(l) = \varepsilon$  for  $l < 0$ . Furthermore,

$$\begin{aligned} \forall l \in \mathbb{N}_0, \quad ((\Delta^\tau \gamma^\nu)^* \downarrow_{++} s)(l) &= \bigwedge_{j \geq 0} \Delta^{j\tau} \downarrow_{++} s(l + j\nu) \\ &= \bigwedge_{J \geq j \geq 0} \Delta^{j\tau} \downarrow_{++} s(l + j\nu) \text{ with } J = \lceil \frac{n_N}{\nu} \rceil \end{aligned}$$

Then,

$$(\Delta^\tau \gamma^\nu)^* \downarrow_{++} s = \bigwedge_{J \geq j \geq 0} (\Delta^{j\tau} \gamma^{j\nu}) \downarrow_{++} s$$

According to Prop. 34 and Lem. 59,

$$\sigma((\Delta^\tau \gamma^\nu)^* \downarrow_{++} s) = \sigma(\psi((\Delta^\tau \gamma^\nu)^* \downarrow_{++} s)(e)) = 0$$



**Third case:**  $0 < \sigma(s) \leq \sigma((\Delta^{\tau} \gamma^{\nu})^*)$ .

The canonical representative of  $s$  is denoted  $p \oplus (\Delta^{\tau_1} \gamma^{\nu_1})^* q$  with  $\tau_1, \nu_1$  in  $\mathbb{N}$  and causal polynomials  $p, q$  in  $\mathcal{F}_{\mathbb{N}_{\max}, \gamma}[\gamma]$  with the canonical representatives

$$p = \bigoplus_{k=1}^{N_p} f_{p,k} \gamma^{n_{p,k}} \text{ and } q = \bigoplus_{k=1}^{N_q} f_{q,k} \gamma^{n_{q,k}}$$

Then, there exists  $L \geq n_{q, N_q}$  such that

$$\forall l \geq L, \quad s(l) = \bigoplus_{k=1}^{N_q} \Delta^{l - \frac{n_{q,k}}{\nu_1}} \rfloor^{\tau_1} f_{q,k}$$

Therefore,

$$\begin{aligned} \forall l \in \mathbb{N}_0, \quad ((\Delta^{\tau} \gamma^{\nu})^* \wr_{+++} s)(l) &= \bigwedge_{R > j \geq 0} \Delta^{j\tau} \wr_{+++} s(l + j\nu) \wedge \\ &\quad \bigwedge_{j \geq R} \Delta^{j\tau} \wr_{+++} \left( \bigoplus_{k=1}^{N_q} \Delta^{l + j\nu - \frac{n_{q,k}}{\nu_1}} \rfloor^{\tau_1} f_{q,k} \right) \end{aligned}$$

with  $J = \lceil \frac{L}{\nu} \rceil$ . Furthermore,

$$\begin{aligned} \forall k, \quad \Delta^{(j+\nu_1)\tau} \wr_{\wr} \left( \Delta^{l + (j+\nu_1)\nu - \frac{n_{q,k}}{\nu_1}} \rfloor^{\tau_1} f_{q,k} \right) &= \Delta^{(j+\nu_1)\tau} \wr_{\wr} \left( \Delta^{\nu\tau_1} \Delta^{l + j\nu - \frac{n_{q,k}}{\nu_1}} \rfloor^{\tau_1} f_{q,k} \right) \\ &= \Delta^{j\tau} \wr_{\wr} \left( \Delta^{\nu\tau_1 - \nu_1\tau} \Delta^{l + j\nu - \frac{n_{q,k}}{\nu_1}} \rfloor^{\tau_1} f_{q,k} \right) \end{aligned}$$

Hence, as  $\frac{\tau}{\nu} \leq \frac{\tau_1}{\nu_1}$ ,

$$\forall k, \quad \Delta^{(j+\nu_1)\tau} \wr_{\wr} \left( \Delta^{l + (j+\nu_1)\nu - \frac{n_{q,k}}{\nu_1}} \rfloor^{\tau_1} f_{q,k} \right) \geq \Delta^{j\tau} \wr_{\wr} \left( \Delta^{l + j\nu - \frac{n_{q,k}}{\nu_1}} \rfloor^{\tau_1} f_{q,k} \right)$$

Therefore,

$$\bigwedge_{j \geq J} \Delta^{j\tau} \wr_{+++} \left( \bigoplus_{k=1}^{N_q} \Delta^{l + j\nu - \frac{n_{q,k}}{\nu_1}} \rfloor^{\tau_1} f_{q,k} \right) = \bigwedge_{j=J}^{J+\nu_1-1} \Delta^{j\tau} \wr_{+++} \left( \bigoplus_{k=1}^N \Delta^{l + j\nu - \frac{n_{q,k}}{\nu_1}} \rfloor^{\tau_1} f_{q,k} \right)$$

Thus,

$$\forall l \in \mathbb{N}_0, \quad ((\Delta^{\tau} \gamma^{\nu})^* \wr_{+++} s)(l) = \bigwedge_{j=0}^{J+\nu_1-1} \left( (\Delta^{j\tau} \gamma^{j\nu}) \wr_{+++} s \right)(l)$$

Then,

$$(\gamma^\nu \Delta^\tau)^* \downarrow_{+++} s = \bigwedge_{j=0}^{J+\nu_1-1} (\Delta^{j\tau} \gamma^{j\nu}) \downarrow_{+++} s$$

Consequently, according to Lem. 59 and Prop. 34,

$$\sigma((\Delta^\tau \gamma^\nu)^* \downarrow_{+++} s) = \sigma(\psi((\Delta^\tau \gamma^\nu)^* \downarrow_{+++} s)(e)) = 0$$

□

**Proposition 50** (Left-division of series in  $\mathcal{F}_{\mathbb{N}_{\max}, \gamma}^{\text{per}, c}[\![\gamma]\!]$ ). *Let  $s_1, s_2$  be two series in  $\mathcal{F}_{\mathbb{N}_{\max}, \gamma}^{\text{per}, c}[\![\gamma]\!]$ .  $s_1 \downarrow_{+++} s_2$  belongs to  $\mathcal{F}_{\mathbb{N}_{\max}, \gamma}^{\text{per}, c}[\![\gamma]\!]$ . If  $s_1$  and  $s_2$  are different from  $\varepsilon$ ,*

- if  $\sigma(s_1) < \sigma(s_2)$ , then  $s_1 \downarrow_{+++} s_2 = \varepsilon$ .
- if  $\sigma(s_1) = \sigma(s_2) = +\infty$ , then  $s_1 \downarrow_{+++} s_2$  is either equal to  $\varepsilon$  or  $\sigma(s_1 \downarrow_{+++} s_2) = +\infty$ .
- if  $\sigma(s_2) \neq +\infty$  and  $\sigma(s_1) \geq \sigma(s_2)$ , then  $\sigma(s_1 \downarrow_{+++} s_2) = \sigma(s_2)$ .

*Proof.* If  $s_1 = \varepsilon$ ,  $s_1 \downarrow_{+++} s_2 = \top$  belongs to  $\mathcal{F}_{\mathbb{N}_{\max}, \gamma}^{\text{per}, c}[\![\gamma]\!]$ . Otherwise, there exist  $N \in \mathbb{N}$ , non-zero causal periodic mappings  $f_1, \dots, f_N$ ,  $n_1, \dots, n_N$  in  $\mathbb{N}_0$ ,  $\tau_1, \dots, \tau_N$  in  $\mathbb{N}_0$ , and  $\nu$  in  $\mathbb{N}$  such that

$$s_1 = \bigoplus_{k=1}^N (\Delta^{\tau_k} \gamma^\nu)^* f_k \gamma^{n_k}$$

According to (2.3) and (2.5),

$$s_1 \downarrow_{+++} s_2 = \bigwedge_{k=1}^N (f_k \gamma^{n_k}) \downarrow_{+++} ((\Delta^{\tau_k} \gamma^\nu)^* \downarrow_{+++} s_2)$$

Then, using Lem. 59, Lem. 60, and Prop. 34,  $s_1 \downarrow_{+++} s_2$  belongs to  $\mathcal{F}_{\mathbb{N}_{\max}, \gamma}^{\text{per}, c}[\![\gamma]\!]$ . Next, the result on the throughput is checked. Three cases are distinguished.

**First Case:**  $\sigma(s_1) < \sigma(s_2)$ .

As  $s_1 \downarrow_{+++} s_2 \leq s_1 \downarrow_{+} s_2$ ,  $s_1 \downarrow_{+++} s_2 = \varepsilon$  according to Prop. 31.

**Second Case:**  $\sigma(s_1) = \sigma(s_2) = +\infty$ .

For all  $k$ ,  $\tau_k = 0$ . Then,

$$s_1 \downarrow_{+++} s_2 = \bigwedge_{k=1}^N (f_k \gamma^{n_k}) \downarrow_{+++} s_2$$

Thus, according to Lem. 59 and Prop. 34,  $s_1 \downarrow_{+++} s_2$  is either equal to  $\varepsilon$  or  $\sigma(s_1 \downarrow_{+++} s_2) = +\infty$ .

**Third Case:**  $\sigma(s_2) \neq +\infty$  and  $\sigma(s_1) \geq \sigma(s_2)$ .

Then, according to Lem. 59 and Lem. 60, for all  $k$ ,

$$\sigma((f_k \gamma^{n_k}) \downarrow_{+++} ((\Delta^{\tau_k} \gamma^\gamma)^* \downarrow_{+++} s_2)) = \sigma(s_2)$$

Thus, according to Prop. 34,  $\sigma(s_1 \downarrow_{+++} s_2) = \sigma(s_2)$ .  $\square$

### A.2.5. Right-Division of Series in $\mathcal{F}_{\mathbb{N}_{\max}, \gamma}^{\text{per}, c} \llbracket \gamma \rrbracket$

The set of causal series in  $\mathcal{F}_{\mathbb{N}_{\max}, \gamma} \llbracket \gamma \rrbracket$  is a complete dioid. Therefore, the product is residuated. Series  $s_2 \downarrow_{+++} s_1$  is the greatest causal series  $s$  such that  $s \otimes s_1 \leq s_2$ . In the following, we investigate whether  $s_2 \downarrow_{+++} s_1$  belongs to  $\mathcal{F}_{\mathbb{N}_{\max}, \gamma}^{\text{per}, c} \llbracket \gamma \rrbracket$  when  $s_1$  and  $s_2$  belong to  $\mathcal{F}_{\mathbb{N}_{\max}, \gamma}^{\text{per}, c} \llbracket \gamma \rrbracket$ . Next, two intermediate lemmas are proved.

**Lemma 61.** *Let  $s$  be a series in  $\mathcal{F}_{\mathbb{N}_{\max}, \gamma}^{\text{per}, c} \llbracket \gamma \rrbracket$  and let  $f$  be a non-zero causal periodic mapping in  $\mathcal{F}_{\mathbb{N}_{\max}}^-$ . For  $n \in \mathbb{N}_0$ ,  $s \downarrow_{+++} (f\gamma^n)$  belongs to  $\mathcal{F}_{\mathbb{N}_{\max}, \gamma}^{\text{per}, c} \llbracket \gamma \rrbracket$ . Furthermore,*

- if  $s = \varepsilon$  or  $\sigma(f\gamma^n) < \sigma(s)$ , then  $s \downarrow_{+++} (f\gamma^n) = \varepsilon$ .
- if  $\sigma(f\gamma^n) = \sigma(s) = +\infty$ , then  $s \downarrow_{+++} (f\gamma^n) = \varepsilon$  or  $\sigma(s \downarrow_{+++} (f\gamma^n)) = \sigma(s)$ .
- if  $\sigma(f\gamma^n) \geq \sigma(s)$  and  $\sigma(s) \neq +\infty$ , then  $\sigma(s \downarrow_{+++} (f\gamma^n)) = \sigma(s)$ .

*Proof.*

$$(s \downarrow_{+++} (f\gamma^n))(l) = \begin{cases} \varepsilon & \text{if } l < 0 \\ s(l+n) \downarrow_{+++} f & \text{if } l \geq 0 \end{cases}$$

**First Case:**  $s = \varepsilon$ .

As  $f$  is a non-zero causal mapping,

$$\forall l \in \mathbb{N}_0, \quad (s \downarrow_{+++} (f\gamma^n))(l) = \varepsilon \downarrow_{+++} f \leq \varepsilon$$

Then,  $s \downarrow_{+++} (f\gamma^n) = \varepsilon$  belongs to  $\mathcal{F}_{\mathbb{N}_{\max}, \gamma}^{\text{per}, c} \llbracket \gamma \rrbracket$ .

**Second Case:**  $\sigma(s) = \sigma(f\gamma^n) = +\infty$ .

The canonical representative of  $s$  is denoted

$$s = \bigoplus_{k=1}^N f_k \gamma^{n_k} \text{ with } n_1 < \dots < n_N$$

For  $l \geq M = \max(0, n_N - n)$ ,

$$(s \downarrow_{+++} (f\gamma^n))(l) = f_N \downarrow_{+++} f$$

Then,

$$s^{\phi_{++}}(f\gamma^n) = \bigoplus_{l=0}^M (s^{\phi_{++}}(f\gamma^n))(l) \gamma^l$$

If  $f_{N\phi_{++}}f = \varepsilon$ , then  $s^{\phi_{++}}(f\gamma^n) = \varepsilon$ . Otherwise, as  $f_{N\phi_{++}}f \leq f_N$  and  $f_{N\phi_{++}}f$  is a non-zero causal mapping,

$$\sigma(s^{\phi_{++}}(f\gamma^n)) = \sigma(\psi(s^{\phi_{++}}(f\gamma^n))(e)) = +\infty$$

Thus,  $s^{\phi_{++}}(f\gamma^n)$  belongs to  $\mathcal{F}_{\mathbb{N}_{\max}, \gamma}^{\text{per}, c}[\Gamma]$ .

**Third case:**  $\sigma(s) > 0$  and  $\sigma(f\gamma^n) = 0$ .

If  $(s^{\phi_{++}}(f\gamma^n))(l) \neq \varepsilon$ , then  $(s^{\phi_{++}}(f\gamma^n))(l) \geq e$  by causality. Thus,

$$s(l+n) \geq (s(l+n))^{\phi_{++}}f \geq f$$

This is absurd as  $\sigma(s) > 0$  and  $\sigma(f\gamma^n) = 0$ . Then,

$$\forall l \in \mathbb{N}_0, \quad (s^{\phi_{++}}(f\gamma^n))(l) = \varepsilon$$

Consequently,  $s^{\phi_{++}}(f\gamma^n) = \varepsilon$  belongs to  $\mathcal{F}_{\mathbb{N}_{\max}, \gamma}^{\text{per}, c}[\Gamma]$ .

**Fourth case:**  $\sigma(s) = 0$ .

The canonical representative of  $s$  is denoted

$$s = \bigoplus_{k=1}^N f_k \gamma^{n_k} \text{ with } n_1 < \dots < n_N \text{ and } f_N = \top$$

For  $l \geq M = \max(0, n_N - n)$ ,

$$(s^{\phi_{++}}(f\gamma^n))(l) = f_{N\phi_{++}}f = \top$$

Then,

$$s^{\phi_{++}}(f\gamma^n) = \bigoplus_{l=0}^{M-1} (s^{\phi_{++}}(f\gamma^n))(l) \gamma^l \oplus \top \gamma^M$$

Thus,  $s^{\phi_{++}}(f\gamma^n)$  belongs to  $\mathcal{F}_{\mathbb{N}_{\max}, \gamma}^{\text{per}, c}[\Gamma]$  and  $\sigma(s^{\phi_{++}}(f\gamma^n)) = 0$ .

**Fifth case:**  $\sigma(f\gamma^n) = +\infty$  and  $+\infty > \sigma(s) > 0$ .

The canonical representative of  $s$  is denoted  $p \oplus (\Delta^\tau \gamma^\nu)^* q$  with  $\tau, \nu$  in  $\mathbb{N}$  and causal polynomials  $p, q$  in  $\mathcal{F}_{\mathbb{N}_{\max}, \gamma}[\gamma]$  with the canonical representatives

$$p = \bigoplus_{k=1}^{N_p} f_{p,k} \gamma^{n_{p,k}} \text{ and } q = \bigoplus_{k=1}^{N_q} f_{q,k} \gamma^{n_{q,k}}$$

Consider  $M = \max(0, n_{q, N_q} - n)$ .

$$\forall l \geq M, \quad s(l+n) = \bigoplus_{k=1}^{N_q} \Delta^{l + \frac{l+n-n_{q,k}}{\nu}} f_{q,k}$$

Then, according to Lem. 18,

$$\begin{aligned} \forall l \geq M, \quad (s^\phi(f\gamma^n))(l) &= s(l+n) \phi f \\ &= \bigoplus_{k=1}^{N_q} \Delta^{l + \frac{l+n-n_{q,k}}{\nu}} f_{q,k} \otimes f^\flat \\ &= \bigoplus_{k=1}^{N_q} f_{k,l} \end{aligned}$$

with  $f_{k,l} = \Delta^{l + \frac{l+n-n_{q,k}}{\nu}} f_{q,k} \otimes f^\flat$ . Clearly,  $f_{k, l+\nu} = \Delta^\tau f_{k,l}$ . As  $\sigma(f\gamma^n) = +\infty$ , according to Lem. 31,  $f^\flat$  is a non-zero periodic mappings. Then, mapping  $f_{k,l}$  is periodic. Furthermore, as  $f^\flat(x) \geq e$  for  $x \geq e$ , there exists  $L \geq M$  such that, for all  $k$ ,  $f_{k,L}$  is causal. Then,

$$\forall l \geq L, \quad (s^\phi_{++}(f\gamma^n))(l) = \bigoplus_{k=1}^{N_q} f_{k,l}$$

Consequently,

$$\begin{aligned} s^\phi_{++}(f\gamma^n) &= \bigoplus_{l=0}^L (s^\phi_{++}(f\gamma^n))(l) \gamma^l \oplus \bigoplus_{k=1}^{N_q} \bigoplus_{l=L}^{+\infty} f_{k,l} \gamma^l \\ &= \bigoplus_{l=0}^L (s^\phi_{++}(f\gamma^n))(l) \gamma^l \oplus (\Delta^\tau \gamma^\nu)^* \left( \bigoplus_{k=1}^{N_q} \bigoplus_{j=0}^{\nu-1} f_{k, L+j} \gamma^{L+j} \right) \end{aligned}$$

Then,  $s^\phi_{++}(f\gamma^n)$  is a causal periodic series. Furthermore, the previous expression leads to

$$\sigma(s^\phi_{++}(f\gamma^n)) = \sigma(\psi(s^\phi_{++}(f\gamma^n))(e)) = \frac{\nu}{\tau} = \sigma(s)$$

Then,  $s^\phi_{++}(f\gamma^n)$  belongs to  $\mathcal{F}_{\mathbb{N}_{\max}, \gamma}^{\text{per}, c}[\gamma]$ . □

**Lemma 62.** *Let  $s$  be a series in  $\mathcal{F}_{\mathbb{N}_{\max}, \gamma}^{\text{per}, c}[\llbracket \gamma \rrbracket]$  and let  $\nu, \tau \in \mathbb{N}$ . Series  $s_{\phi_{++}}^{\prime} (\Delta^{\tau} \gamma^{\nu})^*$  belongs to  $\mathcal{F}_{\mathbb{N}_{\max}, \gamma}^{\text{per}, c}[\llbracket \gamma \rrbracket]$ . Furthermore,*

- *if  $s = \varepsilon$  or  $\sigma(s) > \sigma((\Delta^{\tau} \gamma^{\nu})^*)$ , then  $s_{\phi_{++}}^{\prime} (\Delta^{\tau} \gamma^{\nu})^* = \varepsilon$ .*
- *if  $\sigma(s) \leq \sigma((\Delta^{\tau} \gamma^{\nu})^*)$ , then  $\sigma(s_{\phi_{++}}^{\prime} (\Delta^{\tau} \gamma^{\nu})^*) = \sigma(s)$ .*

*Proof.* According to (2.3),

$$s_{\phi_{++}}^{\prime} (\Delta^{\tau} \gamma^{\nu})^* = \bigwedge_{j \geq 0} s_{\phi_{++}}^{\prime} (\Delta^{j\tau} \gamma^{j\nu})$$

Then,

$$\forall l \in \mathbb{Z}, \quad (s_{\phi_{++}}^{\prime} (\Delta^{\tau} \gamma^{\nu})^*)(l) = \begin{cases} \varepsilon & \text{if } l < 0 \\ \bigwedge_{j \geq 0} s(l + j\nu)_{\phi_{++}} \Delta^{j\tau} & \end{cases}$$

In the rest of this proof, five cases are distinguished.

**First Case:**  $s = \varepsilon$ .

$$s_{\phi_{++}}^{\prime} (\Delta^{\tau} \gamma^{\nu})^* \leq s = \varepsilon$$

Then,  $s_{\phi_{++}}^{\prime} (\Delta^{\tau} \gamma^{\nu})^* = \varepsilon$  belongs to  $\mathcal{F}_{\mathbb{N}_{\max}, \gamma}^{\text{per}, c}[\llbracket \gamma \rrbracket]$ .

**Second Case:**  $\sigma(s) > \sigma((\Delta^{\tau} \gamma^{\nu})^*) = \frac{\nu}{\tau}$ .

As  $\mathcal{F}_{\mathbb{N}_{\max}, \gamma}^{++}[\llbracket \gamma \rrbracket]$  is a complete dioid,  $s_{\phi_{++}}^{\prime} (\Delta^{\tau} \gamma^{\nu})^*$  exists.

$$s_{\phi_{++}}^{\prime} (\Delta^{\tau} \gamma^{\nu})^* = \bigoplus_{k=0}^{+\infty} g_k \gamma^k \text{ with } g_k \in \mathcal{F}_{\mathbb{N}_{\max}}^{++}$$

Then,

$$\forall k \in \mathbb{N}_0, \quad \psi(g_k \gamma^k (\Delta^{\tau} \gamma^{\nu})^*)(e) \leq \psi(s)(e)$$

For  $k \in \mathbb{N}_0$ ,  $g_k \neq \varepsilon$  implies  $\gamma^k (\tau \gamma^{\nu})^* \leq \psi(s)(e)$ . Then,

$$\frac{\nu}{\tau} \geq \sigma(\psi(s)(e)) = \sigma(s)$$

This contradicts the assumption. Therefore,  $g_k = \varepsilon$ . Consequently,  $s_{\phi_{++}}^{\prime} (\Delta^{\tau} \gamma^{\nu})^* = \varepsilon$  belongs to  $\mathcal{F}_{\mathbb{N}_{\max}, \gamma}^{\text{per}, c}[\llbracket \gamma \rrbracket]$ .

**Third Case:**  $\sigma(s) = 0$ .

The canonical representative of  $s$  is denoted

$$s = \bigoplus_{k=1}^{\mathbb{N}} f_k \gamma^{n_k} \text{ with } n_1 < \dots < n_{\mathbb{N}} \text{ and } f_{\mathbb{N}} = \top$$

Then,

$$\begin{aligned} \forall l \in \mathbb{N}_0, \quad (s^{\phi_{+++}} (\Delta^{\tau} \gamma^{\nu})^*) (l) &= \bigwedge_{j \geq 0} s(l + j\nu)^{\phi_{+++}} \Delta^{j\tau} \\ &= \bigwedge_{R > j \geq 0} s(l + j\nu)^{\phi_{+++}} \Delta^{j\tau} \\ &= \left( \bigwedge_{R > j \geq 0} s^{\phi_{+++}} (\Delta^{j\tau} \gamma^{j\nu}) \right) (l) \end{aligned}$$

with  $R = \lceil \frac{l\mathbb{N}}{\nu} \rceil$ . Due to causality, this equality also holds for  $l < 0$ . Therefore,

$$s^{\phi_{+++}} (\Delta^{\tau} \gamma^{\nu})^* = \bigwedge_{R > j \geq 0} s^{\phi_{+++}} (\Delta^{j\tau} \gamma^{j\nu})$$

Then, according to Lem. 61 and Prop. 34,  $s^{\phi_{+++}} (\Delta^{\tau} \gamma^{\nu})^*$  belongs to  $\mathcal{F}_{\mathbb{N}_{\max}, \gamma}^{\text{per}, c}[\gamma]$  and its throughput is equal to  $\sigma(s)$ .

**Fourth Case:**  $\sigma((\Delta^{\tau} \gamma^{\nu})^*) = \frac{\nu}{\tau} > \sigma(s) > 0$ .

The canonical representative of  $s$  is denoted

$$s = p \oplus (\Delta^{\tau_1} \gamma^{\nu_1})^* q$$

with  $\tau_1, \nu_1$  in  $\mathbb{N}$  and  $p, q$  causal polynomials in  $\mathcal{F}_{\mathbb{N}_{\max}, \gamma}[\gamma]$ . Furthermore the canonical representative of  $q$  is denoted  $\bigoplus_{k=1}^{\mathbb{N}} f_k \gamma^{n_k}$  with non-zero causal periodic (with respect to  $X_k$  and  $\omega_k$ ) mappings in  $\mathcal{F}_{\mathbb{N}_{\max}}$ . The condition  $\sigma((\Delta^{\tau} \gamma^{\nu})^*) > \sigma(s)$  implies  $\nu\tau_1 > \tau\nu_1$ .

Let us denote  $X = \max_{1 \leq k \leq \mathbb{N}} X_k$  and  $\omega = \text{lcm}_{1 \leq k \leq \mathbb{N}} \omega_k$ . Consider  $K$  in  $\mathbb{N}$  such that  $\nu_1$  divides  $K\nu$  and  $\omega$  divides  $K\tau$ . According to (2.3),

$$s^{\phi_{+++}} (\Delta^{K\tau} \gamma^{K\nu})^* = \bigwedge_{j \geq 0} s^{\phi_{+++}} (\Delta^{jK\tau} \gamma^{jK\nu})$$

Then,

$$\begin{aligned} \forall l \in \mathbb{N}_0, \quad (s^{\phi_{+++}} (\Delta^{K\tau} \gamma^{K\nu})^*) (l) &= \bigwedge_{j \geq 0} (s^{\phi_{+++}} (\Delta^{jK\tau} \gamma^{jK\nu})) (l) \\ &= \bigwedge_{j \geq 0} s(l + jK\nu)^{\phi_{+++}} \Delta^{jK\tau} \end{aligned}$$

Furthermore, there exists  $L \geq \max_{1 \leq k \leq N} n_k$  such that

$$\forall l \geq L, \quad s(l) = \bigoplus_{k=1}^N \Delta^{\lfloor \frac{l-n_k}{v_1} \rfloor \tau_1} f_k$$

Then, for  $l \in \mathbb{N}_0$ ,

$$\begin{aligned} \left( s^{\not\neq}_{++} \left( \Delta^{K\tau} \gamma^{Kv} \right)^* \right) (l) &= \bigwedge_{R > j \geq 0} s(l + jKv)^{\not\neq}_{++} \Delta^{jK\tau} \\ &\quad \wedge \bigwedge_{j \geq R} \text{Pr}_{++} \left( \bigoplus_{k=1}^N \Delta^{\lfloor \frac{l-n_k}{v_1} \rfloor + jv'} \tau_1 f_k \left( \Delta^{jK\tau} \right)^b \right) \end{aligned}$$

where  $R = \lceil \frac{L}{Kv} \rceil$  and  $v' = \frac{Kv}{v_1}$ .

For  $j \geq R$ , the mapping  $F_j$  in  $\mathcal{F}_{\mathbb{N}_{\max}}$  is defined by

$$F_j = \bigoplus_{k=1}^N \Delta^{\lfloor \frac{l-n_k}{v_1} \rfloor + jv'} \tau_1 f_k \left( \Delta^{jK\tau} \right)^b$$

Consider  $J \in \mathbb{N}$ . For  $x < \tau^{jK}$ ,

$$\begin{aligned} F_{j+J}(x) &= \bigoplus_{k=1}^N \tau_1^{Jv'} \tau_1^{\lfloor \frac{l-n_k}{v_1} \rfloor + jv'} f_k(e) \\ &= \tau_1^{Jv'} F_j(x) \\ &\geq F_j(x) \end{aligned}$$

For  $x \geq X\tau^{(j+J)K}$ ,

$$\begin{aligned} F_{j+J}(x) &= \bigoplus_{k=1}^N \tau_1^{Jv'} \tau_1^{\lfloor \frac{l-n_k}{v_1} \rfloor + jv'} f_k \left( \tau^{(j+J)K} \not\neq x \right) \\ &\geq \bigoplus_{k=1}^N \tau^{JK} \tau_1^{\lfloor \frac{l-n_k}{v_1} \rfloor + jv'} f_k \left( \tau^{(j+J)K} \not\neq x \right) \text{ as } K\tau < \tau_1^{v'} \\ &\geq \bigoplus_{k=1}^N \tau_1^{\lfloor \frac{l-n_k}{v_1} \rfloor + jv'} f_k \left( \tau^{jK} \not\neq x \right) \text{ as } \omega \text{ divides } K\tau \text{ and } \tau^{(j+J)K} \not\neq x \geq X \\ &\geq F_j(x) \end{aligned}$$

Therefore,

$$\begin{aligned} F_{j+J} &\geq F_j \\ \Leftrightarrow \forall x \text{ with } X\tau^{(j+J)K} > x \geq \tau^{jK}, F_{j+J}(x) &\geq F_j(x) \\ \Leftrightarrow \begin{cases} \forall x \text{ with } X > x \geq e, \\ \bigoplus_{k=1}^N \tau_1^{Jv'} \tau_1^{\lfloor \frac{l-n_k}{v_1} \rfloor + jv'} f_k(x) \geq \bigoplus_{k=1}^N \tau_1^{\lfloor \frac{l-n_k}{v_1} \rfloor + jv'} f_k(\tau^{jK} x) \end{cases} \end{aligned}$$



A sufficient condition is

$$\forall k, \quad \tau_1^{j\nu'} \tau_1^{j\nu' + \lfloor \frac{l-n_k}{\nu_1} \rfloor} f_k(e) \geq \tau_1^{j\nu' + \lfloor \frac{l-n_k}{\nu_1} \rfloor} \tau^{Kj} f_k(X) \text{ as } \omega \text{ divides } K\tau$$

As  $\sigma(s) > 0$ , this equation can be written in standard algebra.

$$\forall k, \quad J(\nu'\tau_1 - K\tau) \geq f_k(X) - f_k(e)$$

A sufficient condition is

$$\forall k, \quad J(\nu'\tau_1 - K\tau) \geq f_k(X) - f_k(e)$$

As  $\nu'\tau_1 > K\tau$ , a sufficient condition is

$$J \geq \max_{1 \leq k \leq N} \left( \frac{f_k(X) - f_k(e)}{\nu'\tau_1 - K\tau}, 1 \right) = \tilde{j}$$

Consequently,  $\forall j \geq R, F_{j+\tilde{j}} \geq F_j$ . Then,  $\forall j \geq R, \Pr_{++}(F_{j+\tilde{j}}) \geq \Pr_{++}(F_j)$ . Therefore,

$$\begin{aligned} \forall l \in \mathbb{N}_0, \quad \left( s_{+++}^{\phi} \left( \Delta^{K\tau} \gamma^{K\nu} \right)^* \right) (l) &= \bigwedge_{R > j \geq 0} s(l + jK\nu)_{+++}^{\phi} \Delta^{jK\tau} \wedge \bigwedge_{R+\tilde{j} > j \geq R} \Pr_{++}(F_j) \\ &= \bigwedge_{R+\tilde{j} > j \geq 0} s(l + jK\nu)_{+++}^{\phi} \Delta^{jK\tau} \\ &= \left( \bigwedge_{R+\tilde{j} > j \geq 0} s_{+++}^{\phi} \left( \Delta^{jK\tau} \gamma^{jK\nu} \right) \right) (l) \end{aligned}$$

This equality also holds for  $l < 0$ . Thus,

$$s_{+++}^{\phi} \left( \Delta^{K\tau} \gamma^{K\nu} \right)^* = \bigwedge_{R+\tilde{j} > j \geq 0} s_{+++}^{\phi} \left( \Delta^{jK\tau} \gamma^{jK\nu} \right)$$

According to Lem. 61 and Prop. 34,  $s_{+++}^{\phi} \left( \Delta^{K\tau} \gamma^{K\nu} \right)^*$  belongs to  $\mathcal{F}_{\mathbb{N}_{\max}, \gamma}^{\text{per}, c} [\gamma]$  and

$$\sigma \left( s_{+++}^{\phi} \left( \Delta^{K\tau} \gamma^{K\nu} \right)^* \right) = \sigma(s)$$

Furthermore, as

$$s_{+++}^{\phi} \left( \Delta^{\tau} \gamma^{\nu} \right)^* = \bigwedge_{k=0}^{K-1} \left( s_{+++}^{\phi} \left( \Delta^{K\tau} \gamma^{K\nu} \right)^* \right)_{+++}^{\phi} \left( \Delta^{k\tau} \gamma^{k\nu} \right)$$

According to Lem. 61 and Prop. 34,  $s_{+++}^{\phi} \left( \Delta^{\tau} \gamma^{\nu} \right)^*$  belongs to  $\mathcal{F}_{\mathbb{N}_{\max}, \gamma}^{\text{per}, c} [\gamma]$  and

$$\sigma \left( s_{+++}^{\phi} \left( \Delta^{\tau} \gamma^{\nu} \right)^* \right) = \sigma(s)$$

**Fifth Case:**  $\frac{\nu}{\tau} = \sigma((\Delta^\tau \gamma^\nu)^*) = \sigma(s) > 0$ .

The canonical representative of  $s$  is denoted

$$s = p \oplus (\Delta^{\tau_1} \gamma^{\nu_1})^* q$$

with  $\tau_1, \nu_1$  in  $\mathbb{N}$  and  $p, q$  causal polynomials in  $\mathcal{F}_{\overline{\mathbb{N}}_{\max}, \gamma}[\gamma]$ . Furthermore the canonical representative of  $q$  is denoted  $\bigoplus_{k=1}^N f_k \gamma^{n_k}$  with non-zero causal periodic (with respect to  $X_k$  and  $\omega_k$ ) mappings in  $\mathcal{F}_{\overline{\mathbb{N}}_{\max}}$ . The condition  $\sigma((\Delta^\tau \gamma^\nu)^*) = \sigma(s)$  implies  $\nu \tau_1 = \tau \nu_1$ .

Let us denote  $X = \max_{1 \leq k \leq N} X_k$  and  $\omega = \text{lcm}_{1 \leq k \leq N} \omega_k$ . Consider  $K$  in  $\mathbb{N}$  such that  $\nu_1$  divides  $K\nu$ ,  $\omega$  divides  $K\tau$ , and  $X < K\tau$ . According to (2.3),

$$s_{\phi_{++}} \left( \Delta^{K\tau} \gamma^{K\nu} \right)^* = \bigwedge_{j \geq 0} s_{\phi_{++}} \left( \Delta^{jK\tau} \gamma^{jK\nu} \right)$$

Then,

$$\begin{aligned} \forall l \in \mathbb{N}_0, \quad \left( s_{\phi_{++}} \left( \Delta^{K\tau} \gamma^{K\nu} \right)^* \right) (l) &= \bigwedge_{j \geq 0} \left( s_{\phi_{++}} \left( \Delta^{jK\tau} \gamma^{jK\nu} \right) \right) (l) \\ &= \bigwedge_{j \geq 0} s(l + jK\nu)_{\phi_{++}} \Delta^{jK\tau} \end{aligned}$$

Furthermore, there exists  $L \geq \max_{1 \leq k \leq N} n_k$  such that

$$\forall l \geq L, \quad s(l) = \bigoplus_{k=1}^N \Delta^{\lfloor \frac{l-n_k}{\nu_1} \rfloor \tau_1} f_k$$

Then, for  $l \in \mathbb{N}_0$ ,

$$\begin{aligned} \left( s_{\phi_{++}} \left( \Delta^{K\tau} \gamma^{K\nu} \right)^* \right) (l) &= \bigwedge_{R > j \geq 0} s(l + jK\nu)_{\phi_{++}} \Delta^{jK\tau} \\ &\wedge \bigwedge_{j \geq R} \text{Pr}_{++} \left( \bigoplus_{k=1}^N \Delta^{\lfloor \frac{l-n_k}{\nu_1} \rfloor + j\nu'} \tau_1 f_k \left( \Delta^{jK\tau} \right)^b \right) \end{aligned}$$

where  $R = \lfloor \frac{L}{K\nu} \rfloor$  and  $\nu' = \frac{K\nu}{\nu_1}$ .

For  $j \geq R$  and  $l \in \mathbb{N}_0$ , the mapping  $F_{l,j}$  in  $\mathcal{F}_{\overline{\mathbb{N}}_{\max}}$  is defined by

$$F_{l,j} = \bigoplus_{k=1}^N \Delta^{\lfloor \frac{l-n_k}{\nu_1} \rfloor + j\nu'} \tau_1 f_k \left( \Delta^{jK\tau} \right)^b$$

$F_{l,j}$  is a periodic mapping in  $\mathcal{F}_{\overline{\mathbb{N}}_{\max}}$ . In the following,  $\tilde{L}$  is defined by

$$\tilde{L} = \bigwedge \{ l \in \mathbb{N}_0 \mid F_{l,R} \text{ is causal} \}$$

Clearly,  $\tilde{L} \leq n_1$ , as

$$\begin{aligned} F_{n_1, R} &\geq \Delta^{R\nu'\tau_1} f_1 \left( \Delta^{RK\tau} \right)^b \\ &\geq \Delta^{RK\tau} \left( \Delta^{RK\tau} \right)^b \text{ as } f_1 \text{ is causal and } \frac{\nu}{\tau} = \frac{\nu_1}{\tau_1} \\ &\geq \text{Id} \end{aligned}$$

Therefore,  $\tilde{L} \leq n_1$ .

For  $\tilde{L} > l \geq 0$ , there exists  $\mathfrak{a}$  in  $\mathbb{N}_0$  such that  $F_{l, R}(\mathfrak{a}) < \mathfrak{a}$ . Then,

$$\begin{aligned} F_{l, R+J}(\mathfrak{a}\tau^{JK}) &= \bigoplus_{k=1}^N \tau_1^{J\nu'} \tau_1^{\lfloor \frac{l-n_k}{\nu_1} \rfloor + R\nu'} f_k \left( \left( \Delta^{RK\tau} \right)^b(\mathfrak{a}) \right) \\ &= \tau^{JK} F_{l, R}(\mathfrak{a}) \text{ as } \frac{\nu}{\tau} = \frac{\nu_1}{\tau_1} \\ &< \mathfrak{a}\tau^{JK} \end{aligned}$$

Therefore,

$$\left( s_{\phi_{++}} \left( \Delta^{K\tau} \gamma^{K\nu} \right)^* \right)(l) (\mathfrak{a}\tau^{JK}) \leq F_{l, R+J}(\mathfrak{a}\tau^{JK}) < \mathfrak{a}\tau^{JK}$$

Thus, by causality, for  $\tilde{L} > l \geq 0$ ,

$$\left( s_{\phi_{++}} \left( \Delta^{K\tau} \gamma^{K\nu} \right)^* \right)(l) = \varepsilon$$

For  $l \geq \tilde{L}$ ,  $\forall j \geq R$ ,

$$\begin{aligned} \forall \chi \in \bar{\mathbb{N}}_{\max}, \quad F_{l, j}(\chi) &= \bigoplus_{k=1}^N \tau^{K(j-R)} \tau_1^{R\nu' + \lfloor \frac{l-n_k}{\nu_1} \rfloor} f_k \left( \left( \Delta^{RK\tau} \right)^b \left( \left( \Delta^{(j-R)K\tau} \right)^b(\chi) \right) \right) \\ &= \tau^{(j-R)K} F_{l, R} \left( \left( \Delta^{(j-R)K\tau} \right)^b(\chi) \right) \\ &\geq \tau^{(j-R)K} \left( \Delta^{(j-R)K\tau} \right)^b(\chi) \\ &\geq \chi \end{aligned}$$

Thus,  $F_{l, j}$  is causal. This implies that, for  $l \geq \tilde{L}$ ,

$$\left( s_{\phi_{++}} \left( \Delta^{K\tau} \gamma^{K\nu} \right)^* \right)(l) = \bigwedge_{R > j \geq 0} s(l + jK\nu)_{\phi_{++}} \Delta^{jK\tau} \wedge G_l$$

where  $G_l = \bigwedge_{j \geq R} F_{l,j}$ . Clearly,  $G_l$  is causal and

$$G_{l+v_1} = \bigwedge_{j \geq R} F_{l+v_1,j} = \bigwedge_{j \geq R} \Delta^{\tau_1} F_{l,j} = \Delta^{\tau_1} G_l$$

In the following, it is shown that  $G_l$  is periodic. Consider  $\top > \chi \geq X\tau^{KR}$ . There exists  $J \geq R$  such that  $X\tau^{(J+1)K} > \chi \geq X\tau^{JK}$ . Then,

$$\begin{aligned} G_l(\chi) &= \bigwedge_{j \geq R} \bigoplus_{k=1}^N \tau_1^{\lfloor \frac{l-n_k}{v_1} \rfloor + jv'} f_k \left( \left( \Delta^{jK\tau} \right)^b(\chi) \right) \\ &= \bigoplus_{k=1}^N \tau_1^{\lfloor \frac{l-n_k}{v_1} \rfloor + (J+2)v'} f_k(e) \wedge \bigoplus_{k=1}^N \tau_1^{\lfloor \frac{l-n_k}{v_1} \rfloor + (J+1)v'} f_k \left( \left( \Delta^{(J+1)K\tau} \right)^b(\chi) \right) \\ &\quad \wedge \bigoplus_{k=1}^N \tau_1^{\lfloor \frac{l-n_k}{v_1} \rfloor + Rv'} f_k \left( \left( \Delta^{RK\tau} \right)^b(\chi) \right) \end{aligned}$$

as  $\tau^{(J+2)K} > \chi$  and  $\omega$  divides  $K\tau$ . Then,  $G_l(\tau^K\chi) = \tau^K G_l(\chi)$  for  $\chi \geq X\tau^{KR}$ . Therefore,  $G_l$  is periodic. Furthermore,  $G_{\tilde{l}} \leq \dots \leq G_{\tilde{l}+v_1} = \Delta^{\tau_1} G_{\tilde{l}}$ . Then, for  $l \geq \tilde{L}$ ,

$$G_l = \left( \left( \Delta^{\tau_1} \gamma^{v_1} \right)^* \left( \bigoplus_{k=0}^{v_1-1} G_{\tilde{l}+k} \gamma^{\tilde{l}+k} \right) \right) (l)$$

Consequently, for  $l \geq \tilde{L}$ ,

$$\begin{aligned} \left( s_{\phi_{++}} \left( \Delta^{K\tau} \gamma^{Kv} \right)^* \right) (l) &= \\ \left( \bigwedge_{R > j \geq 0} s_{\phi_{++}} \left( \Delta^{jK\tau} \gamma^{jKv} \right) \wedge \left( \Delta^{\tau_1} \gamma^{v_1} \right)^* \left( \bigoplus_{k=0}^{v_1-1} G_{\tilde{l}+k} \gamma^{\tilde{l}+k} \right) \right) (l) \end{aligned}$$

Due to the results obtained for  $0 \leq l < \tilde{L}$  and to quasi-causality, this equation also holds for  $l < \tilde{L}$ . Then,

$$s_{\phi_{++}} \left( \Delta^{K\tau} \gamma^{Kv} \right)^* = \bigwedge_{R > j \geq 0} s_{\phi_{++}} \left( \Delta^{jK\tau} \gamma^{jKv} \right) \wedge s_1$$

with  $s_1 = \left( \Delta^{\tau_1} \gamma^{v_1} \right)^* \left( \bigoplus_{k=0}^{v_1-1} G_{\tilde{l}+k} \gamma^{\tilde{l}+k} \right)$ . Clearly,  $s_1$  belongs to  $\mathcal{F}_{\overline{\mathbb{N}}_{\max, \gamma}}^{\text{per}, c}[\gamma]$  and  $\sigma(s_1) = \sigma(s)$ . Then, according to Lem. 61 and Prop. 34,  $s_{\phi_{++}} \left( \Delta^{K\tau} \gamma^{Kv} \right)^*$  belongs to  $\mathcal{F}_{\overline{\mathbb{N}}_{\max, \gamma}}^{\text{per}, c}[\gamma]$  and  $\sigma \left( s_{\phi_{++}} \left( \Delta^{K\tau} \gamma^{Kv} \right)^* \right) = \sigma(s)$ . Furthermore, as

$$s_{\phi_{++}} \left( \Delta^{\tau} \gamma^{v} \right)^* = \bigwedge_{k=0}^{K-1} \left( s_{\phi_{++}} \left( \Delta^{K\tau} \gamma^{Kv} \right)^* \right)_{\phi_{++}} \left( \Delta^{k\tau} \gamma^{kv} \right)$$

According to Lem. 61 and Prop. 34,  $s_{\phi_{++}}^{\phi} (\Delta^{\tau} \gamma^{\nu})^*$  belongs to  $\mathcal{F}_{\mathbb{N}_{\max}, \gamma}^{\text{per}, c} \llbracket \gamma \rrbracket$  and  $\sigma(s_{\phi_{++}}^{\phi} (\Delta^{\tau} \gamma^{\nu})^*) = \sigma(s)$ .  $\square$

**Proposition 51** (Right-division of series in  $\mathcal{F}_{\mathbb{N}_{\max}, \gamma}^{\text{per}, c} \llbracket \gamma \rrbracket$ ). *Let  $s_1, s_2$  be two series in  $\mathcal{F}_{\mathbb{N}_{\max}, \gamma}^{\text{per}, c} \llbracket \gamma \rrbracket$ .*

*Series  $s_2^{\phi_{++}} s_1$  belongs to  $\mathcal{F}_{\mathbb{N}_{\max}, \gamma}^{\text{per}, c} \llbracket \gamma \rrbracket$ . If  $s_1$  and  $s_2$  are different from  $\varepsilon$ ,*

- *if  $\sigma(s_1) < \sigma(s_2)$ , then  $s_2^{\phi_{++}} s_1 = \varepsilon$ .*
- *if  $\sigma(s_1) = \sigma(s_2) = +\infty$ , then  $s_2^{\phi_{++}} s_1$  is either equal to  $\varepsilon$  or  $\sigma(s_2^{\phi_{++}} s_1) = +\infty$ .*
- *if  $\sigma(s_2) \neq +\infty$  and  $\sigma(s_1) \geq \sigma(s_2)$ , then  $\sigma(s_2^{\phi_{++}} s_1) = \sigma(s_2)$ .*

*Proof.* If  $s_1 = \varepsilon$ ,  $s_2^{\phi_{++}} s_1 = \top$  belongs to  $\mathcal{F}_{\mathbb{N}_{\max}, \gamma}^{\text{per}, c} \llbracket \gamma \rrbracket$ . Otherwise, there exist  $N \in \mathbb{N}$ , non-zero causal periodic mappings  $f_1, \dots, f_N, n_1, \dots, n_N$  in  $\mathbb{N}_0$ ,  $\tau_1, \dots, \tau_N$  in  $\mathbb{N}_0$ , and  $\nu$  in  $\mathbb{N}$  such that

$$s_1 = \bigoplus_{k=1}^N (\Delta^{\tau_k} \gamma^{\nu})^* f_k \gamma^{n_k}$$

According to (2.3) and (2.5),

$$s_2^{\phi_{++}} s_1 = \bigwedge_{k=1}^N (s_2^{\phi_{++}} (f_k \gamma^{n_k})^{\phi_{++}} (\Delta^{\tau_k} \gamma^{\nu})^*)$$

Then, using Lem. 61, Lem. 62, and Prop. 34,  $s_2^{\phi_{++}} s_1$  belongs to  $\mathcal{F}_{\mathbb{N}_{\max}, \gamma}^{\text{per}, c} \llbracket \gamma \rrbracket$ . Next, the result on the throughput is checked. Three cases are distinguished.

**First Case:**  $\sigma(s_1) < \sigma(s_2)$ .

There exists  $k$  such that  $\sigma((\Delta^{\tau_k} \gamma^{\nu})^*) < \sigma(s_2)$  or  $\sigma(f_k \gamma^{n_k}) < \sigma(s_2)$ . Consequently, according to Lem. 61 and Lem. 62,  $s_2^{\phi_{++}} s_1 = \varepsilon$ .

**Second Case:**  $\sigma(s_1) = \sigma(s_2) = +\infty$ .

For all  $k$ ,  $\tau_k = 0$ . Then,

$$s_2^{\phi_{++}} s_1 = \bigwedge_{k=1}^N s_2^{\phi_{++}} (f_k \gamma^{n_k})$$

Thus, according to Lem. 61 and Prop. 34,  $s_2^{\phi_{++}} s_1$  is either equal to  $\varepsilon$  or  $\sigma(s_2^{\phi_{++}} s_1) = +\infty$ .

**Third Case:**  $\sigma(s_2) \neq +\infty$  and  $\sigma(s_1) \geq \sigma(s_2)$ .

Then, according to Lem. 61 and Lem. 62, for all  $k$ ,

$$\sigma((s_2^{\phi_{++}} (f_k \gamma^{n_k}))^{\phi_{++}} (\Delta^{\tau_k} \gamma^{\nu})^*) = \sigma(s_2)$$

Thus, according to Prop. 34,  $\sigma(s_2^{\phi_{++}} s_1) = \sigma(s_2)$ .  $\square$



# B

## Modeling with Counters

---

Discrete event systems only ruled by standard synchronization (*i.e.*,  $(\max, +)$ -linear systems) are modeled by linear equations in the  $(\max, +)$ -algebra, when daters are used to capture the dynamics. Such systems are also modeled by linear equations in the  $(\min, +)$ -algebra, when counters are used to capture the dynamics. In the following, we investigate the modeling of  $(\max, +)$ -systems with partial synchronization by counters. The goal is to find  $(\min, +)$ -equations describing the dynamics of  $(\max, +)$ -systems with partial synchronization (*i.e.*, equations in the  $(\min, +)$ -algebra similar to (5.8) and (5.9)).

### B.1. Mathematical Preliminaries

In the following, some useful concepts are introduced.

**Definition 54** (Antitone mapping). *Let  $f : E \rightarrow F$  with  $E$  and  $F$  ordered sets. Mapping  $f$  is said to be antitone if*

$$\forall x, y \in E, \quad x \leq y \Rightarrow f(x) \geq f(y)$$

Further, the definition of the  $(\min, +)$ -algebra is recalled.

**Example 47** (Diod  $\overline{\mathbb{N}}_{\min}$ ). *The set  $\mathbb{N}_0 \cup \{+\infty\}$  endowed with  $\min$  as addition and  $+$  as multiplication is a complete dioid denoted  $\overline{\mathbb{N}}_{\min}$ . Its zero element  $\varepsilon$  is equal to  $+\infty$ , its unit element  $e$  and its top element  $\top$  are both equal to  $0$ . The order induced by  $\oplus$  is the dual of the*

standard order in  $\mathbb{N}_0$ . Clearly,  $\overline{\mathbb{N}}_{\min}$  is selective and commutative. This dioid (along with other dioids using  $\min$  as addition and  $+$  as multiplication) is often called  $(\min, +)$ -algebra in the literature.

## B.2. Counter Representation

In this section, we derive a model for  $(\max, +)$ -systems with partial synchronization based on counters. A convenient algebraic structure to express this model is the  $(\min, +)$ -algebra  $\overline{\mathbb{N}}_{\min}$ . Furthermore, we present a method based on this model to compute the output induced by a predefined input.

**Remark 26.** *In the counter representation, we assume that the considered discrete event system is time-driven (i.e., events only occur at clock ticks). This restriction allows us to only consider standard synchronizations with a time-delay  $\tau$  in  $\mathbb{N}_0$  (while  $\tau$  belongs to  $\mathbb{R}_0^+$  in the dater representation).*

### B.2.1. Counters

To capture the timed dynamics of a discrete event system, a mapping, called counter, is associated with each event such that the counter gives the number of occurrences of the considered event before or at a particular time instant. From now on, we consider counters from  $\mathbb{Z}$  to  $\overline{\mathbb{N}}_{\min}$  and no distinction is made in the notation between an event and the associated counter. Hence, for an event  $c$ ,  $c(t)$  denotes the number of occurrences of event  $c$  before or at time  $t$ . This leads to the following interpretation for counters:

$c(t) = e$ : No occurrence of event  $c$  is before or at time  $t$ .

$c(t) \in \mathbb{N}$ : Exactly  $c(t)$  occurrences of event  $c$  are before or at time  $t$ .

$c(t) = \varepsilon$ : An infinity of occurrences of event  $c$  is before or at time  $t$  and no occurrence of event  $c$  is strictly after time  $t$ .

According to the standard order in  $\mathbb{N}_0$ , the number of occurrences of event  $c$  before or at time  $t$  is less than or equal to the number of occurrences of event  $c$  before or at time  $t + 1$ . Then, as the order in  $\overline{\mathbb{N}}_{\min}$  is the dual of the standard order in  $\mathbb{N}_0$ , the number of occurrences of event  $c$  before or at time  $t$  is, according to the order in  $\overline{\mathbb{N}}_{\min}$ , greater than or equal to the number of occurrences of event  $c$  before or at time  $t + 1$ . Therefore,

$$\forall t \in \mathbb{Z}, \quad c(t) \geq c(t + 1)$$

Hence, a counter is antitone. Furthermore, as for dater representation, we assume that an event either occurs at  $t = -\infty$  or at  $t \geq 0$ . This leads to the following condition for counters.

$$\forall t < 0, \quad c(t) = c(t - 1)$$

The previous discussion leads to a formal definition for counters.



**Definition 55** (Counter). A counter, denoted  $c$ , is an antitone mapping from  $\mathbb{Z}$  to  $\overline{\mathbb{N}}_{\min}$  such that  $c(t) = c(t - 1)$  for  $t < 0$ . The set of counters is denoted  $\mathcal{C}$ .

According to Rem. 3,  $\mathcal{C}$  is endowed with an operation  $\oplus$  and an order  $\leq$  induced respectively by the operation  $\oplus$  and the order  $\leq$  in the dioid  $\overline{\mathbb{N}}_{\min}$ .

**Remark 27.** A dater (i.e., a mapping from  $\mathbb{Z}$  to  $\overline{\mathbb{N}}_{\max}$ , as a time-driven dynamics is considered) or a counter is sufficient to fully describe the timing pattern of an event. Hence, it is possible to convert a dater to a counter or, conversely, a counter to a dater. For dater  $d$  and counter  $c$  associated with the same event, these relations are expressed by

$$\begin{aligned} \forall t \in \mathbb{Z}, \quad c(t) &= \max \{k \in \mathbb{Z} \mid d(k - 1) \leq t\} \\ \forall k \in \mathbb{Z}, \quad d(k) &= \min \{t \in \mathbb{Z} \mid c(t) \leq 1k\} \end{aligned}$$

with the convention  $\min \emptyset = +\infty$ .

**Example 48.** Let us consider the dater  $d$  defined by

$$d(k) = \begin{cases} \varepsilon & \text{if } k < 0 \\ 5 & \text{if } k = 0 \\ 7 & \text{if } 1 \leq k < 4 \\ 15 & \text{if } k = 4 \\ \top & \text{if } k \geq 5 \end{cases}$$

The corresponding counter  $c$  is defined by

$$c(t) = \begin{cases} 0 & \text{if } t < 5 \\ 1 & \text{if } 5 \leq t < 7 \\ 4 & \text{if } 7 \leq t < 15 \\ 5 & \text{if } t \geq 15 \end{cases}$$

### B.2.2. Expressing Synchronizations with Counters

In the following, standard and partial synchronizations are expressed in terms of counters. This leads to an algebraic representation based on counters for  $(\max, +)$ -systems with partial synchronization.

#### Expressing Standard Synchronizations with Counters

The standard synchronization “for all  $k \geq l$ , occurrence  $k$  of event  $e_2$  is at least  $\tau$  units of time after occurrence  $k - l$  of event  $e_1$ ” is reformulated as, in the standard algebra, “at all time instant  $t \in \mathbb{Z}$ , the number of occurrences of event  $e_2$  before or at time  $t$  is less than

or equal to the number of occurrences of event  $e_1$  before or at time  $t - \tau$  incremented by  $l$ ". As the order in  $\overline{\mathbb{N}}_{\min}$  is the dual of the standard order, this corresponds to the following inequality in  $\overline{\mathbb{N}}_{\min}$ :

$$\forall t \in \mathbb{Z}, \quad e_2(t) \geq l e_1(t - \tau)$$

Furthermore, the effect of several standard synchronizations on a single event is also expressed by a single inequality in  $\overline{\mathbb{N}}_{\min}$ . For example, the standard synchronizations "for all  $k \geq l_1$ , occurrence  $k$  of event  $e_2$  is at least  $\tau_1$  units of time after occurrence  $k - l_1$  of event  $e_{1,1}$ " and "for all  $k \geq l_2$ , occurrence  $k$  of event  $e_2$  is at least  $\tau_2$  units of time after occurrence  $k - l_2$  of event  $e_{1,2}$ " are both expressed by a single inequality in  $\overline{\mathbb{N}}_{\min}$ :

$$\forall t \in \mathbb{Z}, \quad e_2(t) \geq l_1 e_{1,1}(t - \tau_1) \oplus l_2 e_{1,2}(t - \tau_2)$$

Therefore, matrix inequalities in  $\overline{\mathbb{N}}_{\min}$  are suitable to express standard synchronizations. The standard synchronizations between events in the main system are summarized by

$$\begin{cases} x_1(t) \geq \bigoplus_{i=0}^{T_1} A_{1,i} x_1(t-i) \oplus B_{1,i} u_1(t-i) \\ y_1(t) \geq \bigoplus_{i=0}^{T_1} C_{1,i} x_1(t-i) \end{cases} \quad (\text{B.1})$$

where  $x_1$ ,  $u_1$ , and  $y_1$  respectively correspond to the vectors of counters associated with state, input, and output events in the main system and  $T_1$  denotes the greatest parameters  $\tau$  over all standard synchronizations in the main system. Furthermore, matrices  $A_{1,i}$ ,  $B_{1,i}$ , and  $C_{1,i}$  belong respectively to  $\overline{\mathbb{N}}_{\min}^{n_1 \times n_1}$ ,  $\overline{\mathbb{N}}_{\min}^{n_1 \times m_1}$ , and  $\overline{\mathbb{N}}_{\min}^{p_1 \times n_1}$ . The entries of these matrices are given by the parameters of the standard synchronizations in the main system. In the same way, the standard synchronizations between events in the secondary system are summarized by

$$\begin{cases} x_2(t) \geq \bigoplus_{i=0}^{T_2} A_{2,i} x_2(t-i) \oplus B_{2,i} u_2(t-i) \\ y_2(t) \geq \bigoplus_{i=0}^{T_2} C_{2,i} x_2(t-i) \end{cases} \quad (\text{B.2})$$

where  $x_2$ ,  $u_2$ , and  $y_2$  respectively correspond to the vectors of counters associated with state, input, and output events in the secondary system and  $T_2$  denotes the greatest parameters  $\tau$  over all standard synchronizations in the secondary system. Furthermore, matrices  $A_{2,i}$ ,  $B_{2,i}$ , and  $C_{2,i}$  respectively belong to  $\overline{\mathbb{N}}_{\min}^{n_2 \times n_2}$ ,  $\overline{\mathbb{N}}_{\min}^{n_2 \times m_2}$ , and  $\overline{\mathbb{N}}_{\min}^{p_2 \times n_2}$ . The entries of these matrices are given by the parameters of the standard synchronizations in the secondary system.

To simplify (B.1) and (B.2), the event set of the considered  $(\max, +)$ -system with partial synchronization is extended by additional state events. This allows us to convert (B.1) and (B.2) to first-order recursions. The theoretical validity of this step is ensured by Lem. 63.

**Lemma 63.** *Let  $\tau \in \mathbb{N}$ . In a  $(\max, +)$ -system with partial synchronization, the following synchronizations are equivalent:*

1. “for all  $k \geq l$ , occurrence  $k$  of event  $e_2$  is at least  $\tau$  units of time after occurrence  $k - l$  of event  $e_1$ ”
2. “for all  $k \geq l$ , occurrence  $k$  of event  $e_2$  is at least  $\tau - 1$  units of time after occurrence  $k - l$  of event  $e_i$ ” and “for all  $k \geq 0$ , occurrence  $k$  of event  $e_i$  is at least one unit of time after occurrence  $k$  of event  $e_1$ ” where state event  $e_i$  only appears in the two previous standard synchronizations
3. “for all  $k \geq 0$ , occurrence  $k$  of event  $e_2$  is at least one unit of time after occurrence  $k$  of event  $e_i$ ” and “for all  $k \geq l$ , occurrence  $k$  of event  $e_i$  is at least  $\tau - 1$  units of time after occurrence  $k - l$  of event  $e_1$ ” where state event  $e_i$  only appears in the two previous standard synchronizations

*Proof.* Only  $1 \Leftrightarrow 2$  is checked, as  $1 \Leftrightarrow 3$  can be obtained in the same way.

$1 \Rightarrow 2$ : Let us consider an event  $e_i$  only subject to the following standard synchronization: for all  $k \geq 0$ , occurrence  $k$  of event  $e_i$  is at least one unit of time after occurrence  $k$  of event  $e_1$ . Then,

$$\forall t \in \mathbb{Z}, \quad e_i(t) \geq e_1(t - 1)$$

Event  $e_i$  is only subject to this standard synchronization. Hence, according to the earliest functioning rule,

$$\forall t \in \mathbb{Z}, \quad e_i(t) = e_1(t - 1)$$

Therefore,

$$\forall t \in \mathbb{Z}, \quad e_2(t) \geq le_1(t - \tau) = le_i(t - \tau + 1)$$

Then, in terms of standard synchronizations, “for all  $k \geq l$ , occurrence  $k$  of event  $e_2$  is at least  $\tau - 1$  units of time after occurrence  $k - l$  of event  $e_i$ ”.

$2 \Rightarrow 1$ : Conversely, the two standard synchronizations “for all  $k \geq l$ , occurrence  $k$  of event  $e_2$  is at least  $\tau - 1$  units of time after occurrence  $k - l$  of event  $e_i$ ” and “for all  $k \geq 0$ , occurrence  $k$  of event  $e_i$  is at least one unit of time after occurrence  $k$  of event  $e_1$ ” correspond, in terms of counters, to

$$\forall t \in \mathbb{Z}, \quad e_2(t) \geq le_i(t - \tau + 1) \text{ and } e_i(t) \geq e_1(t - 1)$$

This implies, as the product is isotone in a dioid,

$$\forall t \in \mathbb{Z}, \quad e_2(t) \geq le_1(t - \tau)$$

The previous inequality corresponds to the standard synchronization “for all  $k \geq l$ , occurrence  $k$  of event  $e_2$  is at least  $\tau$  units of time after occurrence  $k - l$  of event  $e_1$ ”.  $\square$

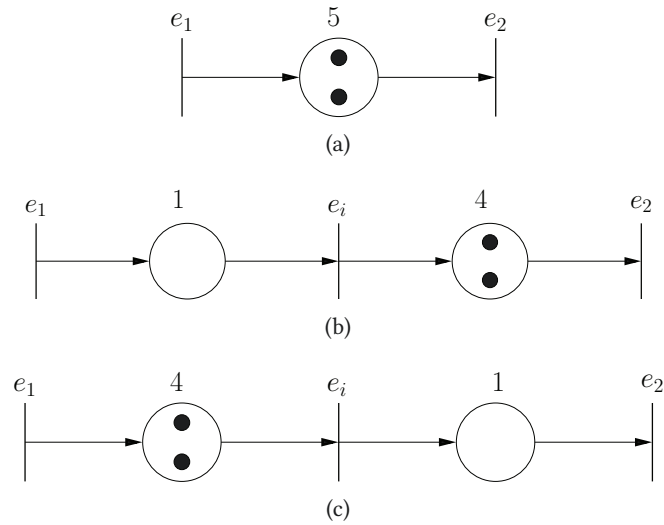

Figure B.1.: Equivalent synchronizations if no other synchronizations affect event  $e_i$

According to Lem. 63, the different synchronization relations between events  $e_1$  and  $e_2$  pictured in Fig. B.1 are equivalent.

By using repetitively Lem. 63, it is possible to set all entries of  $A_{1,i}$  and  $A_{2,i}$  for  $i \geq 2$  and of  $B_{1,i}$ ,  $C_{1,i}$ ,  $B_{2,i}$ , and  $C_{2,i}$  for  $i \geq 1$  to  $\varepsilon$  with additional state events. This leads to the simplified representations for standard synchronizations in the main system and in the secondary system respectively given in (B.3) and (B.4).

$$\begin{cases} x_1(t) \geq A_{1,0}x_1(t) \oplus A_{1,1}x_1(t-1) \oplus B_{1,0}u_1(t) \\ y_1(t) \geq C_{1,0}x_1(t) \end{cases} \quad (\text{B.3})$$

$$\begin{cases} x_2(t) \geq A_{2,0}x_2(t) \oplus A_{2,1}x_2(t-1) \oplus B_{2,0}u_2(t) \\ y_2(t) \geq C_{2,0}x_2(t) \end{cases} \quad (\text{B.4})$$

In the following, only these representations are considered.

**Example 49.** For the  $(\max, +)$ -system with partial synchronization introduced in Ex. 23 (i.e., the supply chain), the number of state events, obtained after state-space extension, amounts to 24 state events in the main system and 46 state events in the secondary system. Due to size restriction, the matrices appearing in (B.3) and (B.4) are not made explicit.

### Expressing Partial Synchronizations with Counters

Partial synchronization “event  $e_2$  can only occur when event  $e_1$  occurs” is expressed by the following condition on counters:

$$\forall t \in \mathbb{Z}, \quad e_1(t) = e_1(t-1) \Rightarrow e_2(t) = e_2(t-1)$$

The effect of several partial synchronizations on a single event is easily expressed by a logical OR. For example, partial synchronizations “event  $e_2$  can only occur when event  $e_{1,1}$  occurs” and “event  $e_2$  can only occur when event  $e_{1,2}$  occurs” correspond to

$$\forall t \in \mathbb{Z}, \quad (e_{1,1}(t) = e_{1,1}(t-1) \text{ or } e_{1,2}(t) = e_{1,2}(t-1)) \Rightarrow e_2(t) = e_2(t-1)$$

To model partial synchronizations in a  $(\max, +)$ -system with partial synchronization, we first recall that, as mentioned in § 5.1.1, only partial synchronizations of state events in the secondary system by state events in the main system are considered. Then, a mapping from  $\mathbb{N}_0$  to  $\{0, 1\}$ , denoted  $\alpha_i$ , is associated with each state event  $x_{2,i}$  in the secondary system. Let us denote  $\mathcal{X}_i$  the set of state events in the main system synchronizing event  $x_{2,i}$ . Then, mapping  $\alpha_i$  is defined by

$$\alpha_i(t) = \begin{cases} 0 & \text{if } t < 0 \text{ or } \exists x \in \mathcal{X}_i | x(t) = x(t-1) \\ 1 & \text{otherwise} \end{cases} \quad (\text{B.5})$$

If  $\alpha_i(t) = 1$ , the partial synchronizations affecting state event  $x_{2,i}$  authorize occurrences at time  $t$ . Otherwise, if  $\alpha_i(t) = 0$ , the partial synchronizations affecting state event  $x_{2,i}$  forbid occurrences at time  $t$ . Hence, the partial synchronizations in a  $(\max, +)$ -system with partial synchronization are expressed by the following condition

$$\forall t \in \mathbb{Z}, \forall i, \quad \alpha_i(t) = 0 \Rightarrow x_{2,i}(t) = x_{2,i}(t-1)$$

### Algebraic Representation of a $(\max, +)$ -system with Partial Synchronization by Counters

The main system is modeled by

$$\begin{cases} x_1(t) \geq A_{1,0}x_1(t) \oplus A_{1,1}x_1(t-1) \oplus B_{1,0}u_1(t) \\ y_1(t) \geq C_{1,0}x_1(t) \end{cases} \quad (\text{B.6})$$

The secondary system is modeled by

$$\begin{cases} x_2(t) \geq A_{2,0}x_2(t) \oplus A_{2,1}x_2(t-1) \oplus B_{2,0}u_2(t) \\ y_2(t) \geq C_{2,0}x_2(t) \\ \forall i, \quad \alpha_i(t) = 0 \Rightarrow x_{2,i}(t) = x_{2,i}(t-1) \end{cases} \quad (\text{B.7})$$

In (B.7), the first two equations represent the standard synchronizations in the secondary system and the third equation represents the partial synchronization of state events in the secondary system by state events in the main system. Then, the main system affects the secondary system through the mappings  $\alpha_i$  which depend on the timing pattern of the state events  $x_1$  in the main system (see (B.5)).

### B.2.3. Input-Output Behavior

In the following, a method to compute the response of a  $(\max, +)$ -system with partial synchronization to a predefined input specified by counters is discussed. As the secondary system does not affect the main system, we first focus on the main system. Second, we investigate the secondary system under a predefined behavior of the main system.

#### Main System

The following method is very similar to the one used for dater representation in § 5.2.3. However, some additional steps are necessary as counters are antitone (while daters are isotone). The synchronizations affecting the main system are summarized in (B.6). Under the earliest functioning rule, we are interested in the greatest, according to the standard order, number of occurrences of state events before or at time  $t$ . Thus, as the canonical order in  $\bar{\mathbb{N}}_{\min}$  is the dual of the standard order, we are actually interested in least solutions. Hence, the number of occurrences of state events occurring before or at time  $t$  (i.e.,  $x_1(t)$ ) is given by the least solution of

$$\begin{cases} x \geq A_{1,0}x \oplus A_{1,1}x_1(t-1) \oplus B_{1,0}u_1(t) \\ t < 0 \Rightarrow x = x_1(t-1) \\ x_1(t-1) \geq x \end{cases}$$

First, a candidate solution  $\tilde{x}_1(t)$  is found by neglecting the condition  $x_1(t-1) \geq x$ . Second, we check that this candidate solution fulfills the omitted condition. For  $t < 0$ ,  $\tilde{x}_1(t) = \tilde{x}_1(t-1)$  by assumption. Hence,  $\tilde{x}_1(t)$  is given by the least solution of

$$x \geq (A_{1,0} \oplus A_{1,1})x \oplus B_{1,0}u_1(t)$$

According to Th. 5, this leads to

$$\forall t < 0, \quad \tilde{x}_1(t) = (A_{1,0} \oplus A_{1,1})^* B_{1,0}u_1(-1) \text{ as } u_1(-1) = u_1(t)$$

For  $t \geq 0$ ,  $\tilde{x}_1(t)$  is given by the least solution of

$$x \geq A_{1,0}x \oplus A_{1,1}\tilde{x}_1(t-1) \oplus B_{1,0}u_1(t)$$

According to Th. 5, this candidate solution is given by

$$\tilde{x}_1(t) = A_{1,0}^* A_{1,1} \tilde{x}_1(t-1) \oplus A_{1,0}^* B_{1,0} u_1(t)$$

These choices ensure that, if the candidate solution is a solution, it is the least solution. Finally, the condition  $\tilde{x}_1(t-1) \geq \tilde{x}_1(t)$  is checked. For  $t < 0$ , the property holds, as  $\tilde{x}_1(t) = \tilde{x}_1(t-1)$ . For  $t \geq 0$ , we reason by induction. First, we prove the initial step (i.e.,  $\tilde{x}_1(-1) \geq \tilde{x}_1(0)$ ). As  $A_{1,0} \oplus A_{1,1} \geq A_{1,0}$  and  $u_1(-1) \geq u_1(0)$ ,

$$\tilde{x}_1(-1) = (A_{1,0} \oplus A_{1,1})^* B_{1,0} u_1(-1) \geq A_{1,0}^* B_{1,0} u_1(0)$$

Furthermore,

$$\begin{aligned} A_{1,0}^* A_{1,1} \tilde{x}_1(-1) &= A_{1,0}^* A_{1,1} (A_{1,0} \oplus A_{1,1})^* B_{1,0} u_1(-1) \\ &= A_{1,0}^* A_{1,1} (A_{1,0}^* A_{1,1})^* A_{1,0}^* B_{1,0} u_1(-1) \text{ according to (2.8)} \\ &\leq A_{1,0}^* A_{1,1} (A_{1,0}^* A_{1,1})^* A_{1,0}^* B_{1,0} u_1(-1) \oplus A_{1,0}^* B_{1,0} u_1(-1) \\ &\leq (A_{1,0}^* A_{1,1})^* A_{1,0}^* B_{1,0} u_1(-1) \\ &\leq (A_{1,0} \oplus A_{1,1})^* B_{1,0} u_1(-1) \text{ according to (2.8)} \\ &\leq \tilde{x}_1(-1) \end{aligned}$$

Hence,  $\tilde{x}_1(-1) \geq A_{1,0}^* A_{1,1} \tilde{x}_1(-1) \oplus A_{1,0}^* B_{1,0} u_1(0) = \tilde{x}_1(0)$ . Second, we assume that  $\tilde{x}_1(t-1) \geq \tilde{x}_1(t)$ . As the product is isotone in a dioid and  $u_1$  is composed of counters,  $A_{1,0}^* A_{1,1} \tilde{x}_1(t-1) \geq A_{1,0}^* A_{1,1} \tilde{x}_1(t)$  and  $A_{1,0}^* B_{1,0} u_1(t) \geq A_{1,0}^* B_{1,0} u_1(t+1)$ . Hence,

$$\begin{aligned} \forall t \in \mathbb{N}_0, \quad \tilde{x}_1(t) &= A_{1,0}^* A_{1,1} \tilde{x}_1(t-1) \oplus A_{1,0}^* B_{1,0} u_1(t) \\ &\geq A_{1,0}^* A_{1,1} \tilde{x}_1(t) \oplus A_{1,0}^* B_{1,0} u_1(t+1) \\ &\geq \tilde{x}_1(t+1) \end{aligned}$$

Consequently, the candidate solution  $\tilde{x}_1(t)$  is a solution. Thus, the state behavior of the main system is given by

$$x_1(t) = \begin{cases} (A_{1,0} \oplus A_{1,1})^* B_{1,0} u_1(-1) & \text{if } t < 0 \\ A_{1,0}^* A_{1,1} x_1(t-1) \oplus A_{1,0}^* B_{1,0} u_1(t) & \text{if } t \geq 0 \end{cases}$$

The number of occurrences of output events before or at time  $t$  (i.e.,  $y_1(t)$ ) is given by the least solution of

$$\begin{cases} x \geq C_{1,0} x_1(t) \\ y_1(t-1) \geq x \end{cases}$$

As for the state events, we first ignored the condition  $y_1(t-1) \geq x$ . This leads to a candidate solution  $\tilde{y}_1(t) = C_{1,0} x_1(t)$ . Second, we check that the condition  $\tilde{y}_1(t-1) \geq \tilde{y}_1(t)$  is fulfilled for the candidate solution. As the product is isotone in a dioid and  $x_1$  is composed of counters,

$$\tilde{y}_1(t-1) = C_{1,0} x_1(t-1) \geq C_{1,0} x_1(t) = \tilde{y}_1(t)$$

Hence, the candidate solution  $\tilde{y}_1(t)$  is a solution. Then,  $y_1(t) = C_{1,0}x_1(t)$ . Thus, by noticing that  $x_1(t) = A_{1,0}^*x_1(t)$  for all  $t \in \mathbb{Z}$ , the main system is described by

$$\begin{cases} x_1(t) = \begin{cases} x_{1,-} & \text{if } t < 0 \\ A_1x_1(t-1) \oplus B_1u_1(t) & \text{if } t \geq 0 \end{cases} \\ y_1(t) = C_1x_1(t) \end{cases} \quad (\text{B.8})$$

where  $x_{1,-} = (A_{1,0} \oplus A_{1,1})^* B_{1,0}u_1(-1)$ ,  $A_1 = A_{1,0}^*A_{1,1}A_{1,0}^*$ ,  $B_1 = A_{1,0}^*B_{1,0}$ , and  $C_1 = C_{1,0}A_{1,0}^*$ .

### Secondary System

The synchronizations affecting the secondary system are summarized in (B.7). By analogy with the main system, the number of occurrences of state events occurring before or at time  $t$  (i.e.,  $x_2(t)$ ) is given by the least solution of

$$\begin{cases} x \geq A_{2,0}x \oplus A_{2,1}x_2(t-1) \oplus B_{2,0}u_2(t) \\ \forall i, \quad \alpha_i(t) = 0 \Rightarrow x_i = x_{2,i}(t-1) \\ x_2(t-1) \geq x \end{cases}$$

where the mappings  $\alpha_i$  are obtained from the behavior of the main system. Notice that, as  $\alpha_i(t) = 0$  for  $t < 0$ , the condition added for partial synchronizations imply  $x_i = x_{2,i}(t-1)$  for  $t < 0$ . For  $t < 0$ , the solution is obtained using a reasoning similar to the one for the main system.

$$\forall t < 0, \quad x_2(t) = (A_{2,0} \oplus A_{2,1})^* B_{2,0}u_2(-1)$$

In the following, we only consider the case  $t \geq 0$ . Due to partial synchronizations, it is not possible to directly use Th. 5 to find  $x_2(t)$ . However, using a reasoning very similar with [1, § 2.5.3], we can assume that  $A_{2,0}$  is strictly lower triangular by deleting state events, lumping state events, and adding input events. This allows us to get rid of the implicit terms by writing the first inequality componentwise. This leads to, for all  $i$ ,

$$x_i \geq \bigoplus_{j=1}^{i-1} (A_{2,0})_{ij} x_j \oplus (A_{2,1}x_2(t-1) \oplus B_{2,0}u_2(t))_i \quad (\text{B.9a})$$

$$\alpha_i(t) = 0 \Rightarrow x_i = x_{2,i}(t-1) \quad (\text{B.9b})$$

$$x_{2,i}(t-1) \geq x_i \quad (\text{B.9c})$$

Let us consider a candidate solution  $z$  defined by

$$z_i = \begin{cases} x_{2,i}(t-1) & \text{if } \alpha_i(t) = 0 \\ \bigoplus_{j=1}^{i-1} (A_{2,0})_{ij} z_j \oplus (A_{2,1}x_2(t-1) \oplus B_{2,0}u_2(t))_i & \text{if } \alpha_i(t) = 1 \end{cases}$$



Next, we prove that the candidate solution  $z$  is the least solution of (B.9). For a particular  $i$  between 1 and  $n_2$ , we assume that the components  $j < i$  of  $z$  are known. Then, it remains to prove that  $z_i$  is the least solution of (B.9).

**Case 1:**  $\alpha_i(t) = 0$ . According to (B.9b),  $z_i = x_{2,i}(t-1)$  is the single valid solution. Then, if this is a solution, this is the least solution. Obviously, if  $z_i = x_{2,i}(t-1)$ , (B.9c) holds. It remains to check (B.9a). As  $x_{2,j}(t-1) \geq z_j$  for  $j < i$ ,  $x_2(t-2) \geq x_2(t-1)$ , and  $u_2(t-1) \geq u_2(t)$ ,

$$\begin{aligned} z_i &= x_{2,i}(t-1) \\ &\geq \bigoplus_{j=1}^{i-1} (A_{2,0})_{ij} x_{2,j}(t-1) \oplus (A_{2,1}x_2(t-2) \oplus B_{2,0}u_2(t-1))_i \\ &\geq \bigoplus_{j=1}^{i-1} (A_{2,0})_{ij} z_j \oplus (A_{2,1}x_2(t-1) \oplus B_{2,0}u_2(t))_i \end{aligned}$$

**Case 2:**  $\alpha_i(t) = 1$ . Equation (B.9a) holds and ensures that, if  $z_i$  is a solution,  $z_i$  is the least solution. As  $\alpha_i(t) = 1$ , (B.9b) does not express any conditions on  $z_i$ . It remains to check (B.9c). As  $x_{2,j}(t-1) \geq z_j$  for  $j < i$ ,  $x_2(t-2) \geq x_2(t-1)$ , and  $u_2(t-1) \geq u_2(t)$ ,

$$\begin{aligned} z_i &= \bigoplus_{j=1}^{i-1} (A_{2,0})_{ij} z_j \oplus (A_{2,1}x_2(t-1) \oplus B_{2,0}u_2(t))_i \\ &\leq \bigoplus_{j=1}^{i-1} (A_{2,0})_{ij} x_{2,j}(t-1) \oplus (A_{2,1}x_2(t-2) \oplus B_{2,0}u_2(t-1))_i \\ &\leq x_{2,i}(t-1) \end{aligned}$$

Thus,  $x_2(t)$  is given by  $z$ . In practice, the entries of  $x_2(t)$  have to be computed in a specific order (*i.e.*, for  $i$  from 1 to  $n_2$ ). For the output events, a reasoning similar to the one for the main system gives  $y_2(t) = C_2x_2(t)$  with  $C_2 = C_{2,0}$ . Thus, the secondary system is described by

$$\begin{cases} x_2(t) = H(x_2(t-1), u_2(t), t) \\ y_2(t) = C_2x_2(t) \end{cases} \quad (\text{B.10})$$

where the mapping  $H$  from  $\overline{\mathbb{R}}_{\max}^{n_2} \times \overline{\mathbb{R}}_{\max}^{m_2} \times \mathbb{Z}$  to  $\overline{\mathbb{R}}_{\max}^{n_2}$  is defined as follows, for  $i$  from 1 to  $n_2$ ,

$$H(x, u, t)_i = \begin{cases} ((A_{2,0} \oplus A_{2,1})^* B_{2,0}u_2(-1))_i & \text{if } t < 0 \\ x_i & \text{if } \alpha_i(t) = 0 \text{ and } t \geq 0 \\ \bigoplus_{j=1}^{i-1} (A_{2,0})_{ij} H(x, u, t)_j \oplus (A_{2,1}x \oplus B_{2,0}u)_i & \text{otherwise} \end{cases} \quad (\text{B.11})$$

**Remark 28.** The results on optimal control developed in § 6 could also be obtained using counters. In particular, counters lead to an easier implementation for MPC with a prediction horizon in the time domain: the counter representation is suitable for online simulations, as the iteration in (B.8) and in (B.10) is done in the time domain. With dater representation, online simulation is also possible, but more complicated, as it is necessary to navigate between time instants and event occurrences. However, the price of counter representation is the restriction to time-driven dynamics, while dater representation is able to model event-driven dynamics.

**Example 50.** For the example introduced in Ex. 23, the output induced by

$$u_{1,1}(t) = u_{1,2}(t) = u_{2,1}(t) = u_{2,2}(t) = \begin{cases} e & \text{for } t < 0 \\ 5 & \text{for } t \geq 0 \end{cases}$$

is computed. For the main system, this leads to

$$y_{1,1}(t) = y_{1,2}(t) = \begin{cases} e & \text{for } t < 10 \\ 1 & \text{for } 10 \leq t < 22 \\ 2 & \text{for } 22 \leq t < 34 \\ 3 & \text{for } 34 \leq t < 46 \\ 4 & \text{for } 46 \leq t < 58 \\ 5 & \text{for } t \geq 58 \end{cases}$$

Furthermore, the mappings  $\alpha_i$  necessary for the dynamics of the secondary system are

$$\alpha_1(t) = \alpha_4(t) = \alpha_5(t) = \alpha_8(t) = \begin{cases} 0 & \text{if } t < 0 \\ 1 & \text{if } t \geq 0 \end{cases}$$

$$\alpha_2(t) = \alpha_6(t) = \begin{cases} 1 & \text{if } t \in \{0, 12, 24, 36, 48\} \\ 0 & \text{otherwise} \end{cases}$$

$$\alpha_3(t) = \alpha_7(t) = \begin{cases} 1 & \text{if } t \in \{10, 22, 34, 46, 58\} \\ 0 & \text{otherwise} \end{cases}$$

The output of the secondary system is given by

$$y_{2,1}(t) = \begin{cases} e & \text{for } t < 27 \\ 1 & \text{for } t \geq 27 \end{cases}$$

$$y_{2,2}(t) = \begin{cases} e & \text{for } t < 51 \\ 1 & \text{for } t \geq 51 \end{cases}$$

As expected, these results confirm the results obtained in Ex. 29 with the dater representation.





## Bibliography

---

- [1] F. Baccelli, G. Cohen, G. J. Olsder, and J.-P. Quadrat. *Synchronization and Linearity: an Algebra for Discrete Event Systems*. John Wiley and Sons, 1992. Available at [cermics.enpc.fr/~cohen-g/documents/BCOQ-book.pdf](http://cermics.enpc.fr/~cohen-g/documents/BCOQ-book.pdf).
- [2] G. Birkhoff. Lattice Theory. In *Colloquium Publications*, volume 25. American Mathematical Society, 3. edition, 1967.
- [3] T. S. Blyth. *Lattices and Ordered Algebraic Structures*. Springer, 2005.
- [4] T. S. Blyth and M. F. Janowitz. *Residuation Theory*. International Series of Monographs in Pure and Applied Mathematics. Pergamon press, 1972.
- [5] T. Brunsch. *Modeling and Control of Complex Systems in a Dioid Framework*. PhD thesis, Fachgebiet Regelungssysteme - Technische Universität Berlin, Germany and LARIS - Université d'Angers, France, January 2014.
- [6] C. G. Cassandras and S. Laforune. *Introduction to Discrete Event Systems*. Springer, 2. edition, 2008.
- [7] G. Cohen. Residuation and Applications. In *Special Issue on École de Printemps d'Informatique Théorique*, Île de Noirmoutier, France, May 1998. INRIA.
- [8] G. Cohen, P. Moller, J.-P. Quadrat, and M. Viot. Algebraic Tools for the Performance Evaluation of Discrete Event Systems. *Proceedings of the IEEE*, 77:39–58, January 1989. Special Issue on Discrete Event Systems.
- [9] G. Cohen, S. Gaubert, and J.-P. Quadrat. From First to Second-Order Theory of Linear Discrete Event Systems. In *Proceedings of the 12th IFAC World Congress*, pages 679–682, Sydney, Australia, July 1993.
- [10] G. Cohen, S. Gaubert, and J.-P. Quadrat. Timed Event Graphs with Multipliers and Homogeneous Min-Plus Systems. *IEEE Transactions on Automatic Control*, 43:1296–1302, September 1998.

- [11] B. Cottenceau. *Contribution à la Commande de Systèmes à Evénements Discrets : Synthèse de Correcteurs pour les Graphes d'Événements Temporisés dans les Dioïdes*. PhD thesis, LISA - Université d'Angers, France, October 1999.
- [12] B. Cottenceau, L. Hardouin, J.-L. Boimond, and J.-L. Ferrier. Synthesis of Greatest Linear Feedback for Timed Event Graphs in Dioid. *IEEE Transactions on Automatic Control*, 44:1258–1262, June 1999.
- [13] B. Cottenceau, L. Hardouin, M. Lhommeau, and J.-L. Boimond. Data Processing Tool for Calculation in Dioid. In *Proceedings of the 5th International Workshop on Discrete Event Systems, WODES*, Ghent, Belgium, August 2000. Available at [www.istia.univ-angers.fr/~hardouin/outils.html](http://www.istia.univ-angers.fr/~hardouin/outils.html).
- [14] B. Cottenceau, L. Hardouin, J.-L. Boimond, and J.-L. Ferrier. Model Reference Control for Timed Event Graphs in Dioids. *Automatica*, 37:1451–1458, September 2001.
- [15] B. Cottenceau, L. Hardouin, and J.-L. Boimond. Modeling and Control of Weight-Balanced Timed Event Graphs in Dioids. *IEEE Transactions on Automatic Control*, 59:1219–1231, May 2014.
- [16] B. Cottenceau, S. Lahaye, and L. Hardouin. Modeling of Time-Varying Max-Plus Systems by Means of Weighted Timed Event Graphs. In *Proceedings of the 12th International Workshop on Discrete Event Systems, WODES*, pages 465–470, Paris, France, May 2014.
- [17] J. E. R. Cury and F. L. Baldissera. Systems Biology, Synthetic Biology and Control Theory: a Promising Golden Braid. *Annual Reviews in Control*, 37:57–67, 2013.
- [18] X. David-Henriet, L. Hardouin, J. Raisch, and B. Cottenceau. Optimal Control for Timed Event Graphs under Partial Synchronization. In *Proceedings of the 52nd IEEE Conference on Decision and Control, CDC*, pages 7609–7614, Firenze, Italy, December 2013.
- [19] X. David-Henriet, L. Hardouin, J. Raisch, and B. Cottenceau. Modeling and Control for Max-Plus Systems with Partial Synchronization. In *Proceedings of the 12th International Workshop on Discrete Event Systems, WODES*, pages 105–110, Paris, France, May 2014.
- [20] B. De Schutter and T. J. J. van den Boom. Model Predictive Control for Max-Plus-Linear Discrete Event Systems. *Automatica*, 37:1049–1056, July 2001.
- [21] B. De Schutter and T. J. J. van den Boom. MPC for Discrete-Event Systems with Soft and Hard Synchronisation Constraints. *International Journal of Control*, 76:82–94, January 2003.

- 
- [22] S. Gaubert. *Théorie des Systèmes Linéaires dans les Dioides*. PhD thesis, École Nationale Supérieure des Mines de Paris, France, July 1992.
- [23] S. Gaubert and C. Klimann. Rational Computation in Dioid Algebra and its Application to Performance Evaluation of Discrete Event Systems. In *Algebraic Computing in Control*, volume 165 of *Lecture Notes in Control and Information Sciences*, pages 241–252. Springer, 1991.
- [24] M. Gondran and M. Minoux. *Graphs, Dioids and Semirings: New Models and Algorithms (Operations Research/Computer Science Interfaces Series)*. Springer, 2008.
- [25] L. Hardouin, C.A. Maia, B. Cottenceau, and M. Lhommeau. Observer Design for (max,plus)-Linear Systems. *IEEE Transactions on Automatic Control*, 55:538–543, February 2010.
- [26] B. Heidergott, G. J. Olsder, and J. W. van der Woude. *Max Plus at Work. Modeling and Analysis of Synchronized Systems: a Course on Max-Plus Algebra and its Applications*. Princeton Series in Applied Mathematics. Princeton University Press, 2006.
- [27] L. E. Holloway, B. H. Krogh, and A. Giua. A Survey of Petri Net Methods for Controlled Discrete Event Systems. *Discrete Event Dynamic Systems: Theory and Applications*, 7: 151–190, 1997.
- [28] J. E. Hopcroft, R. Motwani, and J. D. Ullman. *Introduction to Automata Theory, Languages, and Computation*. Addison-Wesley Longman Publishing, 3. edition, 2006.
- [29] J. Kuntzmann. *Théorie des Réseaux*. Dunod, 1972.
- [30] C.A. Maia, L. Hardouin, R. Santos-Mendes, and B. Cottenceau. Optimal Closed-loop Control of Timed Event Graphs in Dioids. *IEEE Transactions on Automatic Control*, 48: 2284–2287, December 2003.
- [31] E. Menguy, J.-L. Boimond, L. Hardouin, and J.-L. Ferrier. Just-in-Time Control of Timed Event Graphs: Update of Reference Input, Presence of Uncontrollable Input. *IEEE Transactions on Automatic Control*, 45:2155–2159, November 2000.
- [32] P. Moller. *Théorie Algébrique des Systèmes à Événements Discrets*. PhD thesis, École Nationale Supérieure des Mines de Paris, France, December 1988.
- [33] T. Murata. Petri Nets: Properties, Analysis and Applications. *Proceedings of the IEEE*, 77:541–580, January 1989. Special Issue on Discrete Event Systems.
- [34] I. Necoara, T. J. J. van den Boom, B. De Schutter, and H. Hellendoorn. Stabilization of Max-Plus-Linear Systems Using Model Predictive Control: The Unconstrained Case. *Automatica*, 44:971–981, April 2008.

*Bibliography*

---

- [35] P. J. Ramadge and W. M. Wonham. Supervisory Control of a Class of Discrete Event Processes. *SIAM Journal on Control and Optimization*, 25:206–230, 1987.



# Declaration

---

I declare that this thesis has been composed by myself, that the work contained herein is my own except where explicitly stated otherwise, and that this work has not been submitted for any other degree or professional qualification except as specified.

*Berlin, January 2015*

---

Xavier David-Henriet