

Supporting Information

Fluorescent Rhodamines and Fluorogenic Carbopyronines for Super-Resolution STED Microscopy in Living Cells

Alexey N. Butkevich, Gyuzel Yu. Mitronova, Sven C. Sidenstein, Jessica L. Klocke, Dirk Kamin, Dirk N. H. Meineke, Elisa D'Este, Philip-Tobias Kraemer, Johann G. Danzl, Vladimir N. Belov,* and Stefan W. Hell**

anie_201511018_sm_miscellaneous_information.pdf

Table of Contents

Commercially available cell-permeant dyes for functional protein analysis	S-2
Fluorescence properties of dyes 1a – 1k and their HaloTag ligand conjugates 1a -Halo – 1k -Halo	S-3
Absorption/emission spectra and fluorescence quantum yield determination	S-3
Fluorescence intensity changes of substrates 1a -Halo – 1k -Halo in the presence of a HaloTag fusion protein	S-6
Fluorescence intensity changes of substrates 1a -Halo – 1k -Halo in the presence of surfactants	S-7
Live-cell imaging with HaloTag substrates 1a -Halo – 1k -Halo	S-8
STED imaging with dyes <i>580R</i> , <i>580CP</i> , <i>610CP</i> , <i>620CP</i> , <i>650SiR</i> (1e-h,j) and SiR-tubulin probe	S-8
Transfection and live labeling	S-11
Live cell nanoscopy images	S-13
Control experiments	S-22
General experimental information and synthesis	S-24
2,2'-(2-Bromo-1,4-phenylene)bis(4,4-dimethyl-4,5-dihydrooxazole) (SI-1)	S-25
1,1'-(2-Bromo-1,4-phenylene)bis(4-methyl-2,6,7-trioxabicyclo[2.2.2]octane) (SI-3)	S-26
Fluorescent dye <i>500R</i> (1a)	S-28
Fluorescent dye <i>515R</i> (1b)	S-30
Fluorescent dye <i>520R</i> (1c)	S-32
Fluorescent dye <i>580R</i> (1d)	S-34
Fluorescent dye <i>580CP</i> (1e)	S-36
Fluorescent dye <i>610CP</i> (1f)	S-42
Fluorescent dye <i>620CP</i> (1g)	S-46
Fluorescent dye <i>630CP</i> (1h)	S-51
Fluorescent dye <i>SiR</i> (1i)	S-56
Fluorescent dye <i>650SiR</i> (1j)	S-56
Fluorescent dye <i>670SiR</i> (1k)	S-62
References	S-69
NMR spectra of compounds 1a – 1k , SI-1 – SI-25	S-70

Commercially available cell-permeant dyes for functional protein analysis

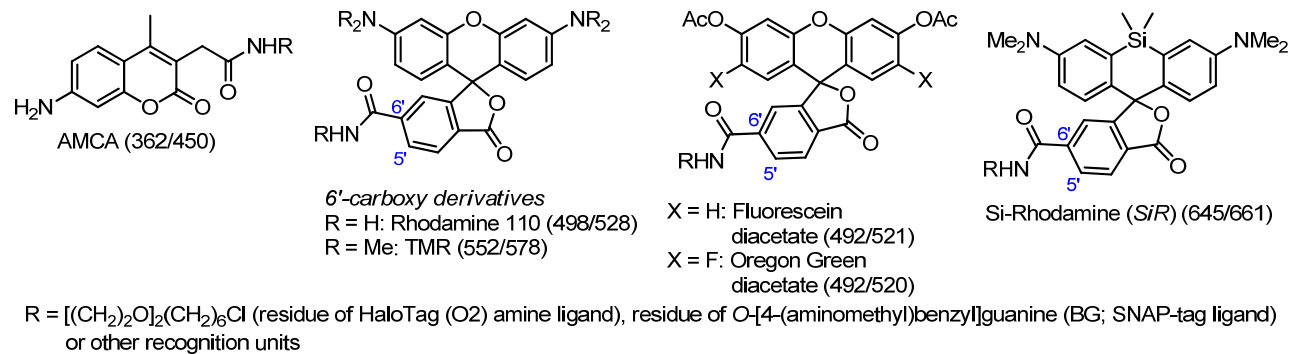

Figure S1. Commercial cell-permeant HaloTag ligands and SNAP-tag ligands obtained from 6'-carboxy derivatives of fluorescent dyes. Absorption and emission maxima are given in brackets.

Fluorescence properties of dyes 1a – 1k and their HaloTag ligand conjugates 1a-Halo – 1k-Halo

Absorption/emission spectra and fluorescence quantum yield determination

The absorption spectra were recorded on a Varian Cary 4000 UV-Vis spectrophotometer. The emission spectra were recorded on a Varian Cary Eclipse fluorescence spectrophotometer. The fluorescence quantum yields of the dyes **1a-1k** were determined in PBS (pH 7.4) solutions according to the literature procedure.^[S1] The following dyes were used as references for relative quantum yield measurements:

Atto590 ($\Phi_f = 0.80$ in water, excitation at 550 nm) for *580CP* (**1e**),
Atto594 ($\Phi_f = 0.85$ in PBS (pH 7.4), excitation at 560 nm) for *580R* (**1d**),
Oxazine 4 ($\Phi_f = 0.63$ in methanol, excitation at 600 nm) for *610CP* (**1f**),
Atto633 ($\Phi_f = 0.64$ in water, excitation at 620 nm) for *620CP* (**1g**) and *630CP* (**1h**),
Oxazine 1 ($\Phi_f = 0.14$ in ethanol, excitation at 640 nm^[S2]) for *SiR* (**1i**), *650SiR* (**1j**) and *670SiR* (**1k**).

The photophysical data are given in Table 1 in the main part of the manuscript.

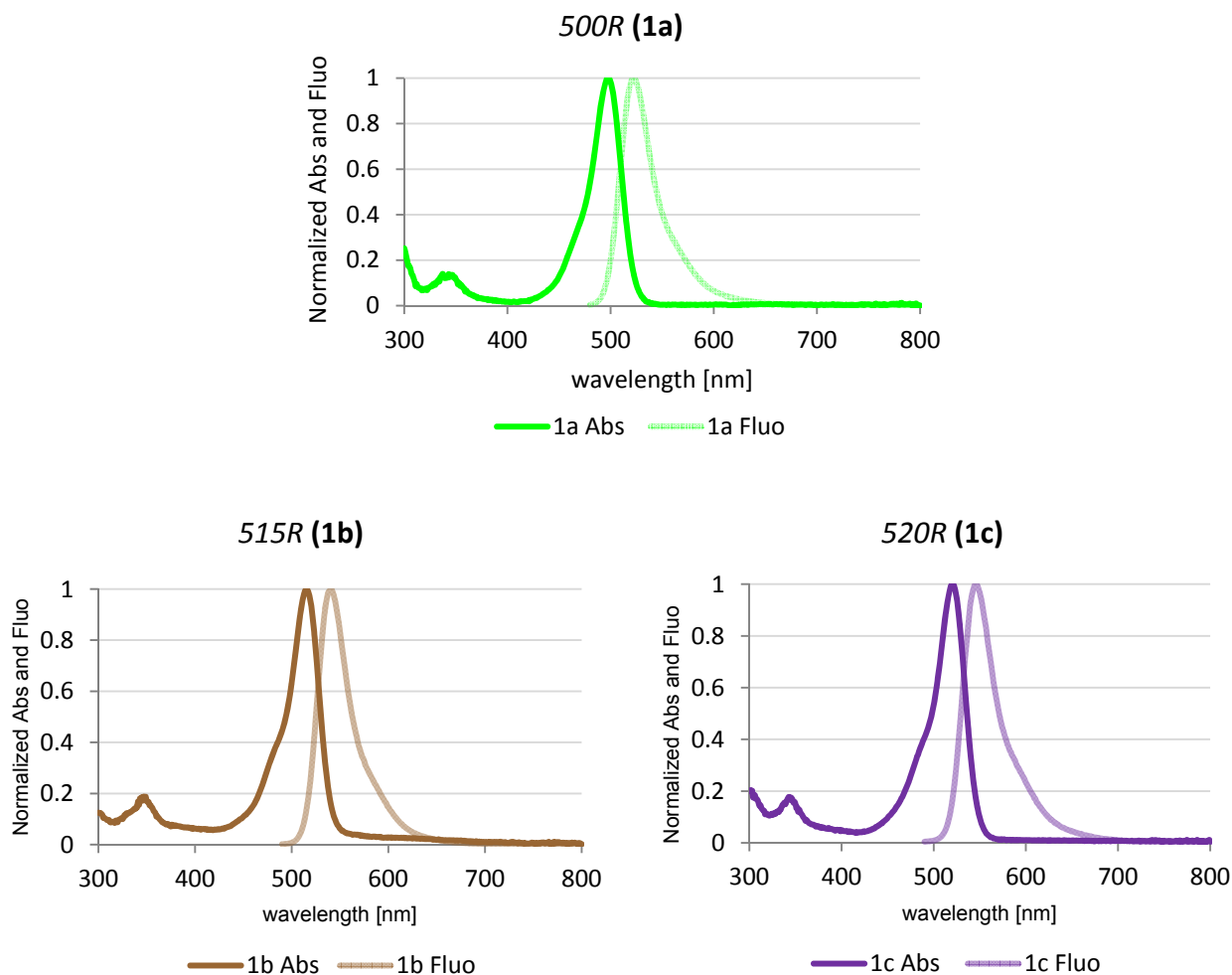

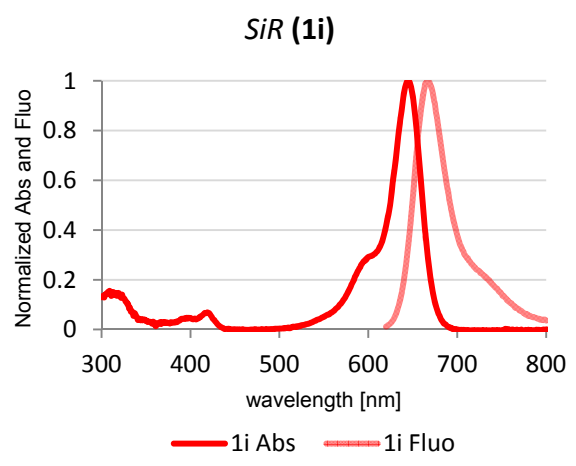
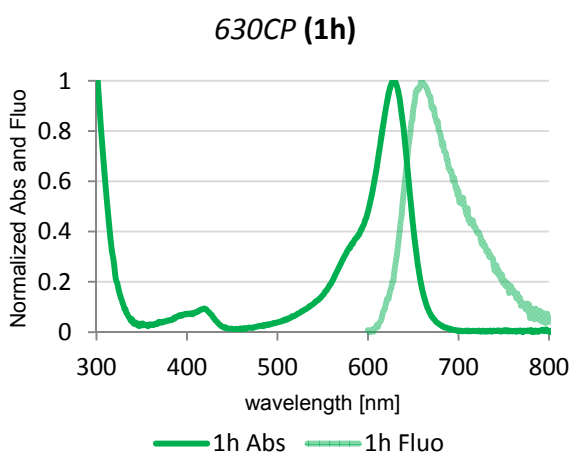
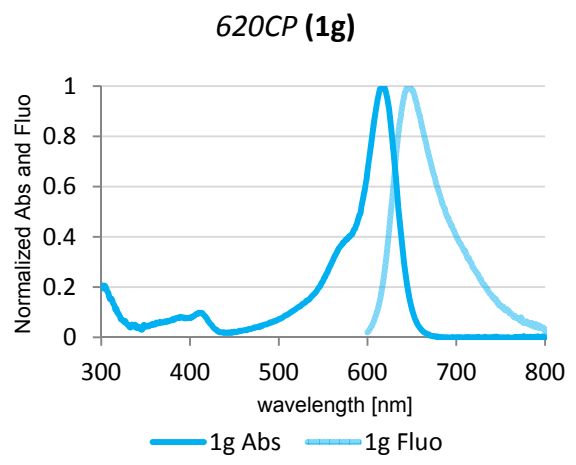
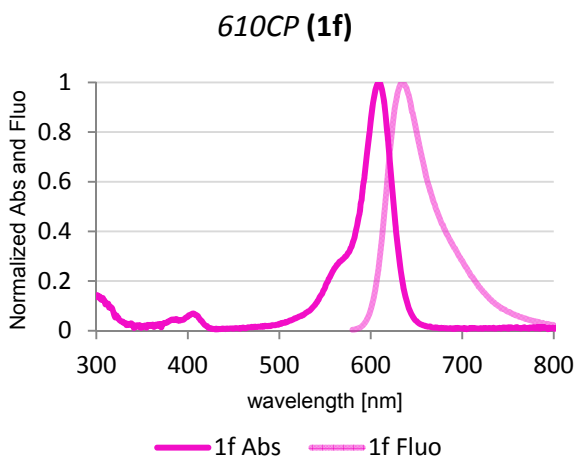
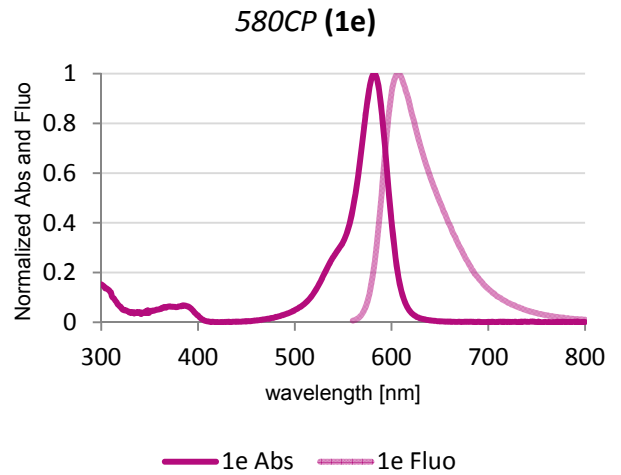
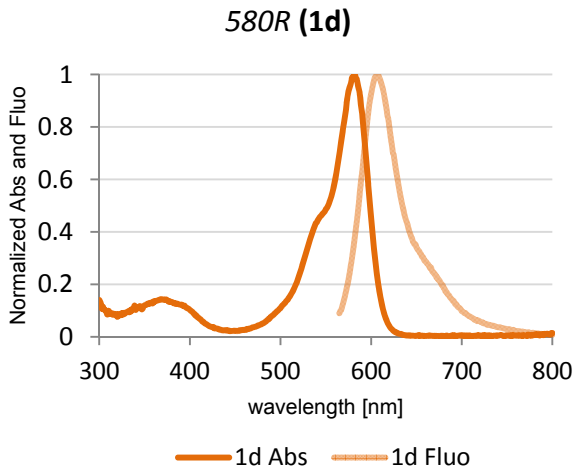

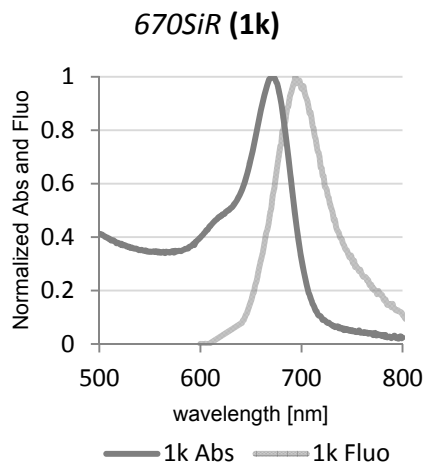
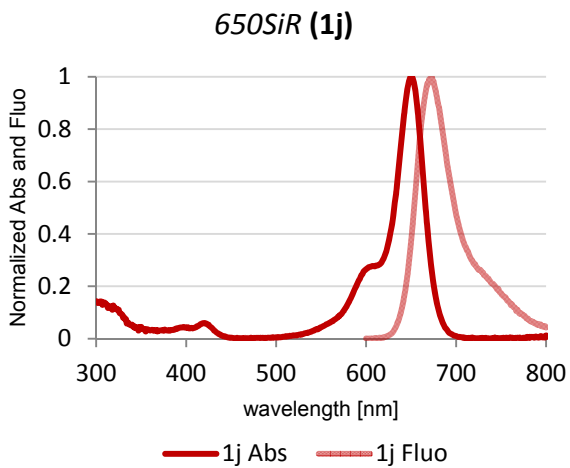

Figure S2. Absorption (Abs) and emission (Fluo) spectra of the dyes **1a-1k**.

Fluorescence intensity changes of substrates 1a-Halo – 1k-Halo in the presence of a HaloTag fusion protein

In 1.5 mL test tubes (Eppendorf), 2 μ L of 25 μ M stock solution of a dye-ligand conjugate (**1a-k-Halo**) in DMSO was added to 100 μ L of

- 1) 10% FBS (FBS Superior, available from Biochrom AG, cat. No. S 0615) in DMEM (“high glucose” (4.5 g/L), no *l*-glutamine, no pyruvate, no Phenol Red; by Gibco[®], available from Life Technologies, cat. No. 31053-028) *or*
- 2) 810 nM HaloTag[®] Standard Protein (HaloTag protein fused to GST (glutathione *S*-transferase), M = 61 kDa; available from Promega, cat. No. G4491), prepared by dissolution of a 30 μ g sample in 607 μ L of 10% FBS in DMEM

and incubated at 37 °C for 2 h (all samples prepared in duplicates; protein/dye ratio = 1.62). The samples were aliquoted (45 μ L each) onto a 96-well microplate, and fluorescence intensity was measured on an Infinite M1000 PRO (Tecan) microplate reader in 10 min intervals over 1 h (excitation and emission bandwidths set to 10 nm). The excitation and emission wavelengths were selected as follows:

Dye	500R (1a)	515R (1b)	520R (1c)	580R (1d)	580CP (1e)	610CP (1f)	620CP (1g)	630CP (1h)	SiR (1i)	650SiR (1j)	670SiR (1k)
Excitation wavelength, nm	500	505	510	570	570	600	610	620	640	640	660
Detection wavelength, nm	525	543	546	607	607	635	647	660	670	672	700

The last three readings of two samples per dye (6 values total) were averaged, and the results presented as fluorescence intensity ratios for solutions containing HaloTag protein/solutions containing FBS in DMEM only.

Fluorescence intensity increase upon reaction with HaloTag protein

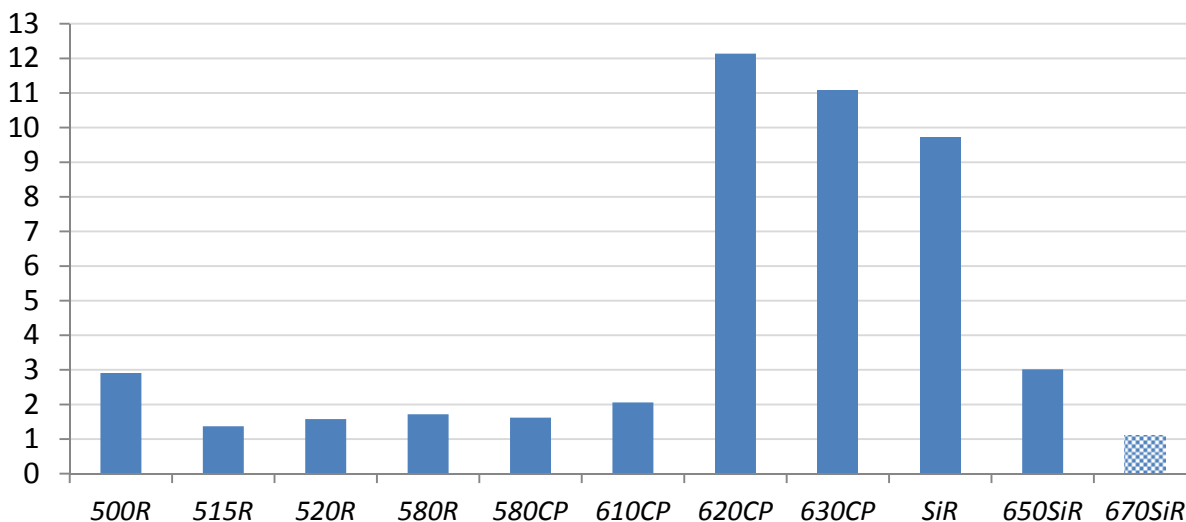

Figure S3. Fluorescence intensity changes upon reaction of dye-ligand conjugates (**1a-k-Halo**) with HaloTag protein in DMEM + 10% FBS. Fluorescence emission of *670SiR* is insufficiently above the background level for correct ratio estimation.

Fluorescence intensity changes of substrates 1a-Halo – 1k-Halo in the presence of surfactants

In 1.5 mL test tubes (Eppendorf), 5 μ L of 25 μ M stock solution of a dye-ligand conjugate (1a-k-Halo) in DMSO was added to 250 μ L of

- 1) 0.1 mg/mL BSA in PBS (pH 7.4),
- 2) 0.1 mg/mL BSA in PBS (pH 7.4) containing 0.5% sodium dodecyl sulfate (SDS, anionic surfactant)
or
- 3) 0.1 mg/mL BSA in PBS (pH 7.4) containing 0.5% cetyltrimethylammonium bromide (CTAB, cationic surfactant)

and incubated at 37 $^{\circ}$ C for 2 h (all samples prepared in duplicates; BSA/dye ratio = 3). The samples were aliquoted (50 μ L each) onto a 96-well microplate, and fluorescence intensity was measured on an Infinite M1000 PRO (Tecan) microplate reader in 10 min intervals over 1 h (excitation and emission bandwidths set to 10 nm). The excitation and emission wavelengths were selected as follows:

Dye	500R (1a)	515R (1b)	520R (1c)	580R (1d)	580CP (1e)	610CP (1f)	620CP (1g)	630CP (1h)	SiR (1i)	650SiR (1j)	670SiR (1k)
Excitation wavelength, nm	500	505	510	570	570	600	610	620	640	640	660
Detection wavelength, nm	525	543	546	607	607	635	647	660	670	672	700

The last three readings of two samples per dye (6 values total) were averaged, and the results presented as fluorescence intensity ratios for SDS (sample with BSA+SDS/sample with BSA only) and CTAB (sample with BSA+CTAB/sample with BSA only).

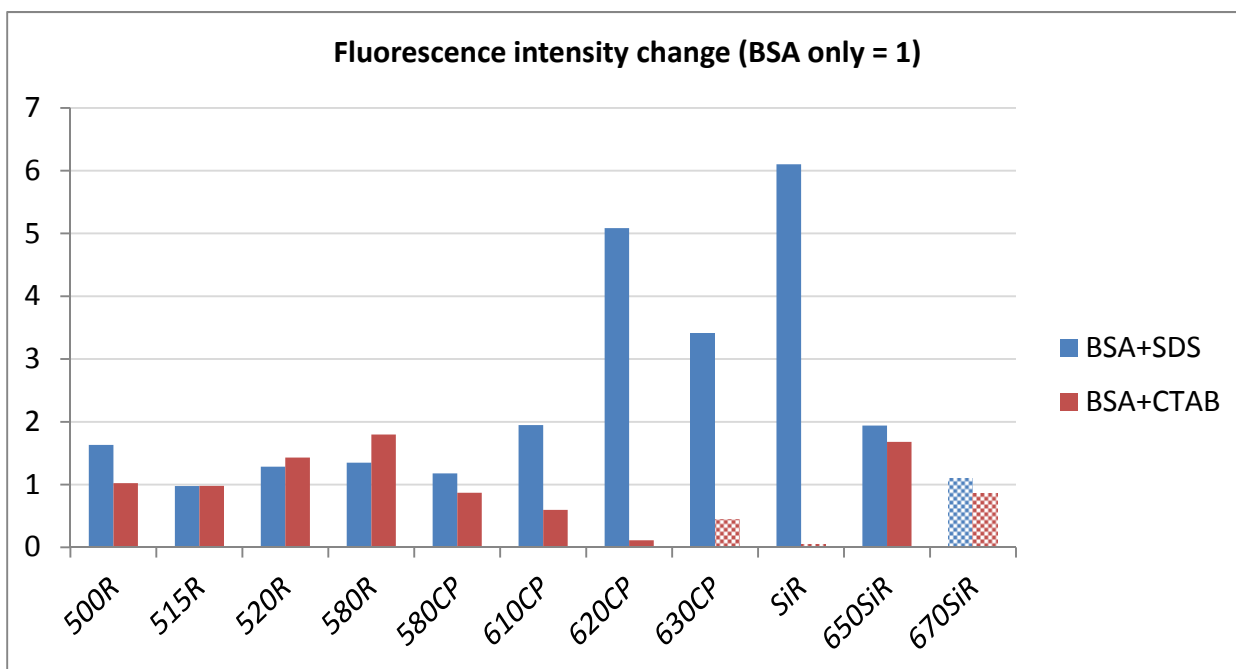

Figure S4. Fluorescence intensity changes upon addition of a surfactant to dye-ligand conjugate (1a-k-Halo) solutions in 0.1 mg/mL BSA in PBS. Crosshatched bars denote values insufficiently above the background and therefore impossible to estimate precisely.

Live-cell imaging with HaloTag substrates 1a-Halo – 1k-Halo

STED imaging with dyes *580R*, *580CP*, *610CP*, *620CP*, *650SiR* (1e-h,j) and SiR-tubulin probe

These dyes were imaged using the two-color STED 775 quad scanning microscope (Abberior Instruments, Göttingen, Germany) equipped with an Olympus IX83 microscope stand and an Olympus UPlanSApo 100x/1.4 OIL objective. For excitation, pulsed lasers at 561 nm, 594 nm and 640 nm are implemented to provide the different excitation wavelengths for the dyes. The STED laser is pulsed at 775 nm. Fluorescence detection was time-gated with a gate delay of ~500 ps relative to the excitation laser pulse and a gate duration of ~8 ns. Two spectral detection channels were used: 605–625 nm and 650–720 nm. For single color measurements with *580R* and *610CP* the excitation wavelength was 594 nm, for *580CP* the excitation was 561 nm and counts in both detection channels were summed up. For the dual-color STED measurements in Figure 4, at each pixel first excitation light at 640 nm was applied for 40 μ s followed by excitation light at 594 nm for 20 μ s. STED light was applied throughout. *580R* fluorescence was collected in the short wavelength detection channel, *SiR* fluorescence in the long wavelength detection channel. For the dual-color STED measurements in Figure S17 both color channels were recorded linewise. Counts of 3 scans per line for *SiR* fluorescence and 2 scans per line for *580CP* fluorescence were accumulated with a pixel dwell time of 12 μ s for both color channels.

Excitation and STED wavelengths as well as spectral detection channels are summarized in Figure S5 for *580R* (or *580CP*) and *SiR*.

620CP, *630CP*, *650SiR* images were acquired using a pixel-interleaved imaging scheme within the software ImSpector (Max-Planck-Innovation) where a pixel was first imaged in STED and then in confocal mode with individual pixel dwell times depending on the brightness of the dye. Fluorescence was detected in the corresponding spectral detection channel. Pixel size was usually ~20 nm.

Image processing was done with ImSpector software. Images are displayed as raw data.

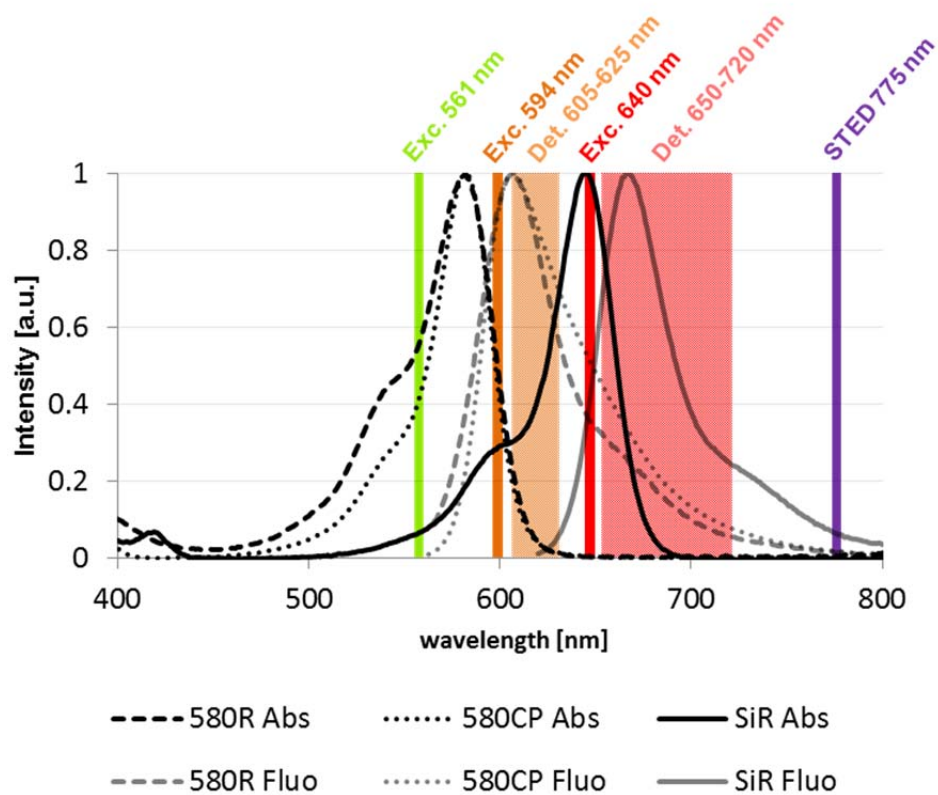

Figure S5. Two-color STED imaging scheme applied to *580R*, *580CP* and *SiR* dyes (*580CP*: excitation at 561 nm, *580R*: excitation at 594 nm, detection at 605 – 625 nm; *SiR*: excitation at 640 nm, detection at 650 – 720 nm; STED wavelength: 775 nm for both dyes).

STED imaging with dyes 500R, 515R and 520R

The organic dyes 500R, 515R and 520R were imaged using a home-built STED microscope. For 500R the common ~ 590 nm STED wavelength was used. For 515R and 520R a STED wavelength of 618 nm was chosen. Alternatively, a commercially available instrument with STED wavelength at 660 nm (Leica Microsystems) should be usable with these dyes.

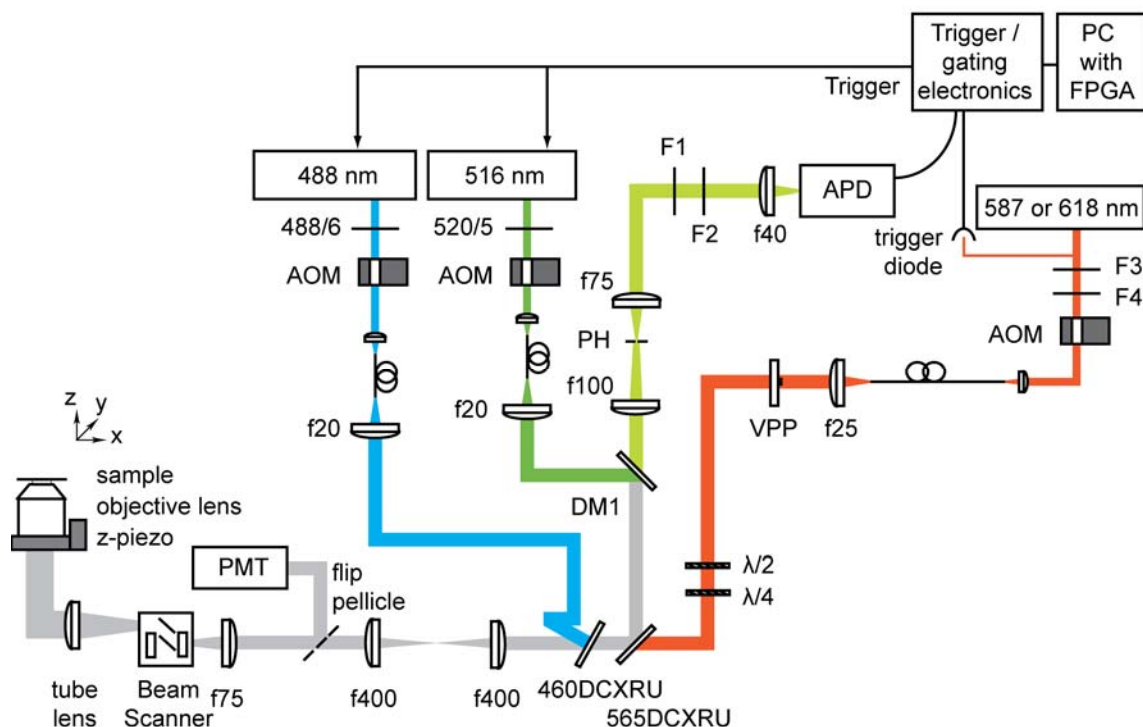

Figure S6. Scheme of the home-built STED setup.

STED light (587 nm or 618 nm) was delivered by a pulsed fibre laser (Rainbow Prototype, IPG Photonics, CA, Mountain View, USA, pulse repetition rate: ~ 20 MHz, pulse duration ~ 1 ns for 587 nm, ~ 580 ps for 618 nm). Excitation light was obtained from laser diodes (516 nm: LDH-D-C-510, PicoQuant, Berlin, Germany and 488 nm: PicoTA, PicoQuant and Toptica Photonics, Graefelfing, Germany) and synchronized pulse-to-pulse with the STED laser by home-built electronics. Laser outputs were spectrally cleaned by band pass filters, switched and intensity-controlled by acousto-optical modulators and coupled into polarization maintaining single-mode fibres. The output of the STED fibre was guided onto a vortex phase plate (VPP1b or VPP1a, RPC Photonics, Rochester, NY, USA) imprinting a helical phase shift on the beam and thereby creating a doughnut-shaped depletion pattern in the focal plane. $\lambda/2$ - and $\lambda/4$ -plates were inserted into the STED beam path to create circular polarization. Dichroic mirrors (460dextru and 565dextru, Chroma, Bellows Falls, VT, USA) were used to combine beams. For focusing and fluorescence collection an oil immersion objective lens (HCX-PL-APO 100x/1.4-0.7 OIL CS, Leica Microsystems, Wetzlar, Germany) in

combination with a tube lens (200 mm, Leica) was used. Laser beams were scanned by a home-built scanner (“Quad Scanner”) including four galvanometer scan mirrors. Focus fine positioning was accomplished by a piezo translator (Mipos 100PL CAP, Piezosystem Jena, Jena, Germany). Fluorescence was imaged onto a pinhole (PH) with a diameter of 50 μm corresponding to ~ 0.8 times the Airy disk at this position. Fluorescence emission was filtered and focused on an avalanche photodiode (APD) (SPCM-AQRH-13, Excelitas, Waltham, MA, USA). The APD signal was time-gated by home-built electronics with a gate delay of ~ 1 ns relative to the excitation laser pulse and a gate duration of ~ 10 ns. For adjustment, a pellicle beam splitter (BP145B1, Thorlabs, Newton, NJ, USA) was flipped into the beam path and laser light reflected from gold nanospheres was collected by a photomultiplier tube (PMT) (H10723-01, Hamamatsu Photonics). The designation fxx gives the focal length of lenses in mm. Experimental control and image acquisition were done with ImSpector software (www.imspector.de).

For imaging of *500R*: Excitation wavelength: 488 nm; STED wavelength: 587 nm. DM1: none. F1: HC525/50 BrightLine band pass (Semrock, Rochester, NY, USA). F2: none. F3: 591/6 BrightLine band pass (Semrock). F4: 594 StopLine notch (Semrock).

For imaging of *515R* and *520R*: Excitation wavelength: 516 nm; STED wavelength: 618 nm. DM1: 514 RazorEdge (Semrock). F1: 532 StopLine notch (Semrock), angle-tuned. F2: 550/49 BrightLine band pass (Semrock). F3: ET615lp long pass (Chroma). F4: 620/14 BrightLine band pass (Semrock).

Imaging parameters and data processing: all power values refer to the back aperture of the objective lens. Actual power at the sample is lower due to finite transmission of the objective lens.

Transfection and live labeling

Cells were grown on #1.5 coverslips and cultured at 37°C with 5% CO₂ in DMEM (Dulbecco’s modified Eagle’s medium) supplemented with 10% FBS (fetal bovine serum), 1% sodium pyruvate and 1% penicillin/streptomycin. For the expression of vimentin-HaloTag fusion protein cells were transfected with 3 μg DNA/well using TurboFect™ Transfection Reagent (Fermentas/Thermo Scientific™, Life Technologies brand) in a 6 well plate. 24 hrs after transfection cells were incubated with the respective dye (**1d-k-Halo**, typically 1 μM) for 20 minutes at growth conditions, washed for 10-30 minutes and placed in an imaging chamber with pre-warmed HDMEM (37°C, DMEM lacking Phenol Red, 10 mM HEPES, pH7.4 1% penicillin/streptomycin). Live STED imaging was performed at room temperature.

Two-color labeling with *580R* (or *580CP*) and SiR-tubulin^[S3] was done as follows: HeLa cells were transfected with the vimentin-HaloTag fusion protein 24 hrs prior to cell labeling. Cells were incubated with the SiR-tubulin probe (500 nM in growth medium) to label endogenous tubulin. After 20 minutes the *580R*

dye (**1d**-Halo, Figure 4) was added to reach a final concentration of 1 μM , followed by further 20 minutes incubation. In the case of two-color labeling with *580CP* (**1e**-Halo, Figure S17) and SiR-tubulin, cells were incubated with both dyes simultaneously for 20 min (both at 1 μM concentration). Cells were afterwards washed with HDMEM for 10 minutes at 37°C and imaged at room temperature.

Live cell nanoscopy images

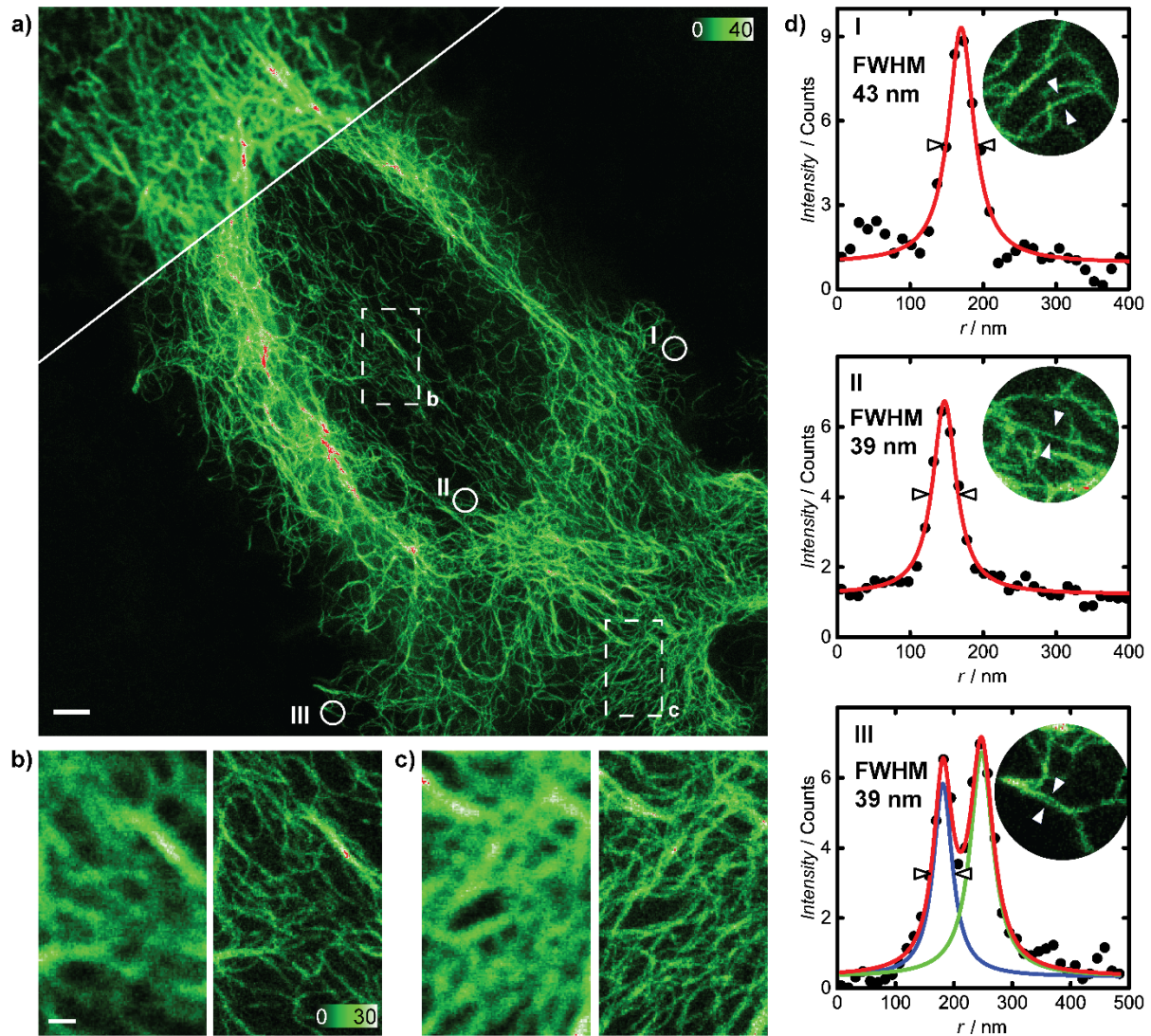

Figure S7. (a) STED image of a living HeLa cell expressing a vimentin-HaloTag fusion protein stained with 500R (1a-Halo, 1 μ M for 20 min). Confocal image of the same cell is shown in the upper left corner. (b), (c) Zoomed views of the areas indicated in panel (a). Left images: Confocal. Right images: STED. (d) Line profiles taken across the filaments marked by the arrows in the zoomed views. Profiles were averaged over 5-10 pixels along the filaments and fitted to single or double Lorentzians yielding full width at half maximum values of \sim 40 nm. The two filaments in subpanel III are separated by 66 nm. Excitation power: 1.2 μ W, STED power: 10 mW, pixel dwell time: 5 μ s, pixel size: 22 nm for STED, 25 nm for confocal image. For the STED image each line was scanned 4 times and counts at corresponding pixels were summed up. Figure shows data slightly smoothed with a 1.2 pixel wide Gaussian. Scale bars: (a) 2 μ m, (b) 500 nm.

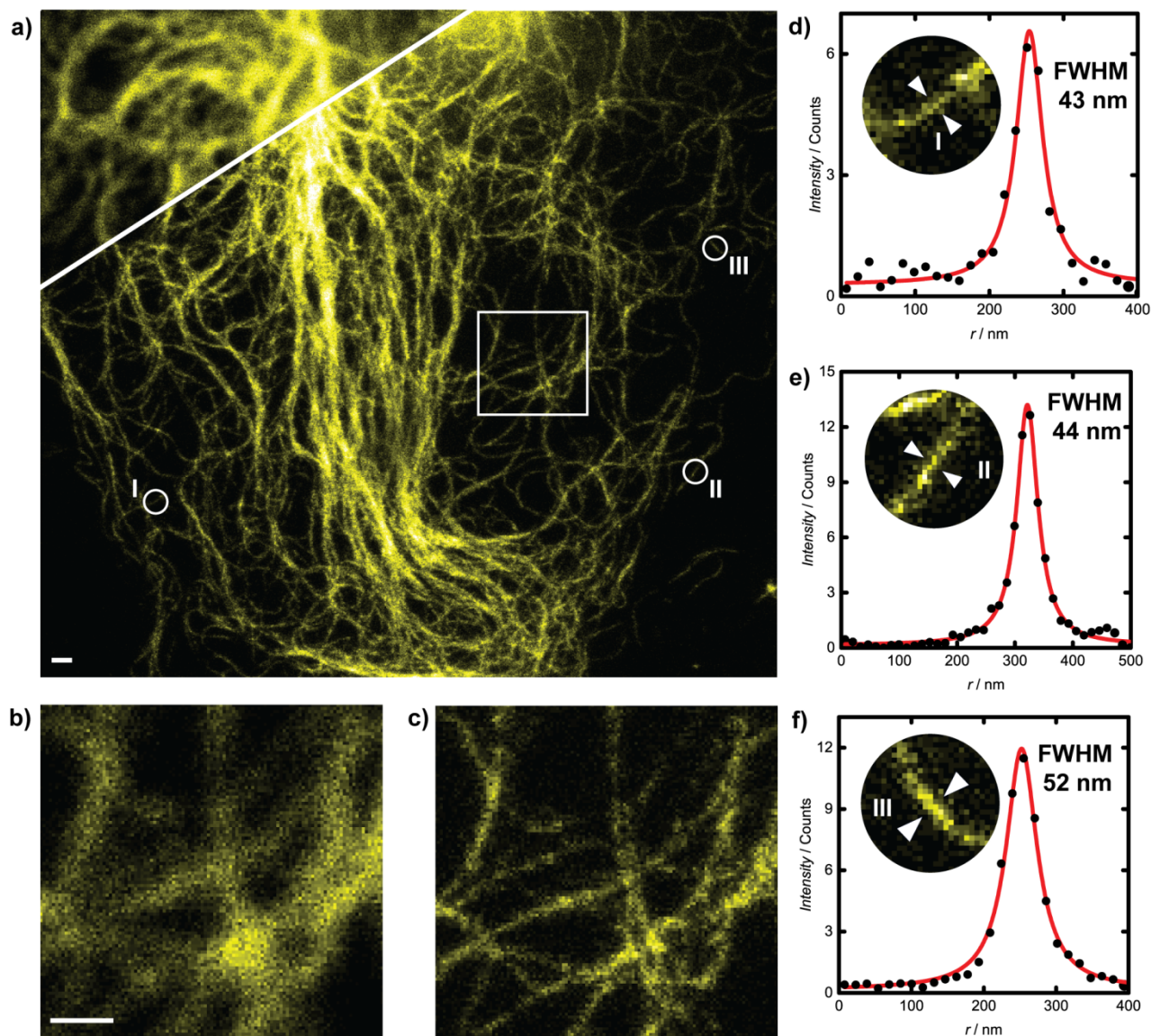

Figure S8. (a) STED image of vimentin filaments in a living HeLa cell expressing a vimentin-HaloTag fusion protein after incubation with *515R* (**1b**-Halo, 1 μ M for 20 min). Confocal data in top left corner. Panels (b) and (c) show zoomed views of the region marked in (a) of the confocal and STED images, respectively. Panels (d) to (f) show line profiles along a line between the arrowheads, drawn perpendicular to the filaments. Positions are indicated in (a) and perspective close-ups are shown as insets. Counts were averaged over five pixels along the direction of the filament. The spatial coordinate along the line is represented by r . Fitting with the Lorentzian function yielded the indicated full width at half maximum (FWHM) values yielding an optical resolution ≤ 50 nm. Excitation power: 1.2 μ W, STED power: 9 mW, pixel dwell time: 30 μ s, pixel size: 23 nm for STED, 25 nm for confocal image. For the STED image each line was scanned 2 times and counts at corresponding pixels were summed up. Figure shows raw data. Scale bar: 500 nm.

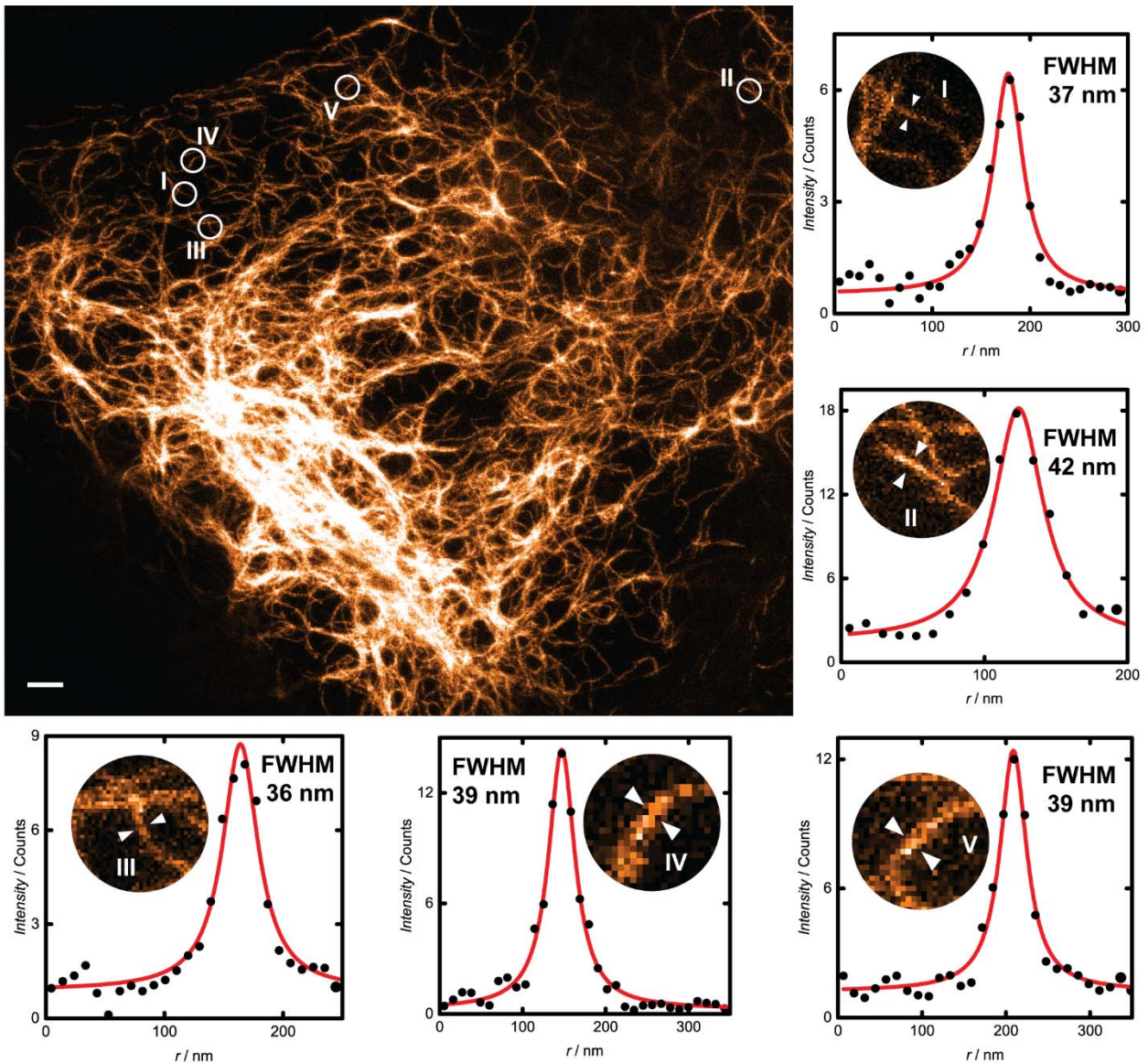

Figure S9. STED image of vimentin filaments in a living cell expressing vimentin-HaloTag fusion protein after incubation with *520R* (1c-Halo, 1 μM for 20 min). Figure 2 in the main text corresponds to the central portion of this image. Panels show zoomed views and the corresponding line profiles drawn perpendicular to the indicated filaments. Counts were averaged over five pixels along the direction of the filament and fitted to the Lorentzian function. Resulting full-width at half maximum values are given for each fit, providing an upper boundary for the optical resolution of 40 nm. Scale bar: 1 μm . Excitation power: 1.6 μW ; STED power: 14 mW; pixel dwell time: 20 μs , pixel size: 18 nm for STED, 20 nm for confocal image. For the STED image each line was scanned 2 times and counts at corresponding pixels were summed up. Figure shows raw data.

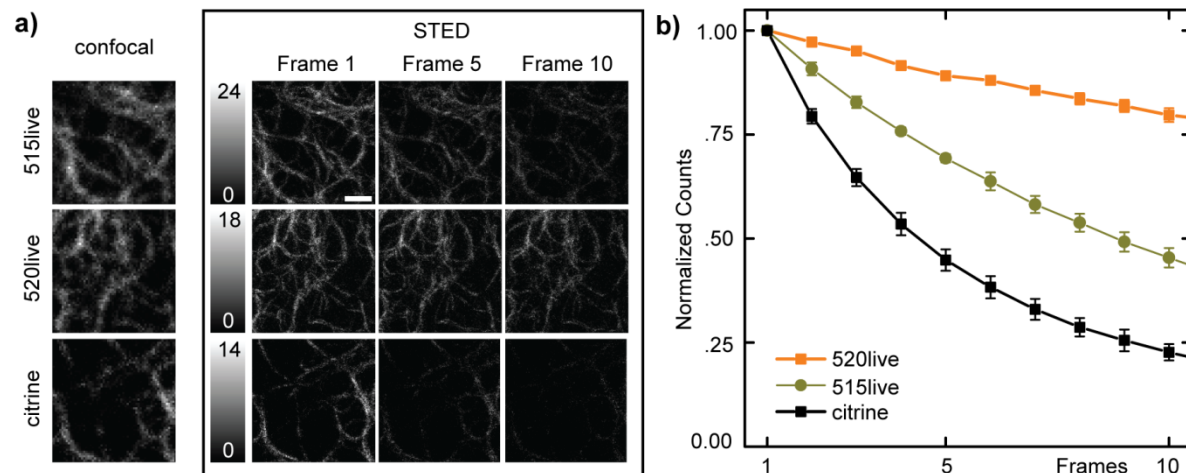

Figure S10. Photostability of *515R* and *520R* stainings of vimentin filaments compared with that of Citrine (fluorescent protein fused with vimentin) under repetitive STED imaging. Images in panel (a) exemplify single frames of STED image series consisting of 10 scans of the same region. Color maps are linear and kept constant for each series. For data in panel (b), counts of each image were summed up and normalized to the value of the first image of the respective series. Data in panel (b) represent mean values \pm standard deviation of five STED image series each measured in a different cell. Imaging parameters were the same for all three fluorophores. Excitation power: $0.3 \mu\text{W}$, STED power: 6.4 mW , pixel dwell time: $40 \mu\text{s}$, pixel size: 30 nm . Scale bar: 500 nm . Images show raw data.

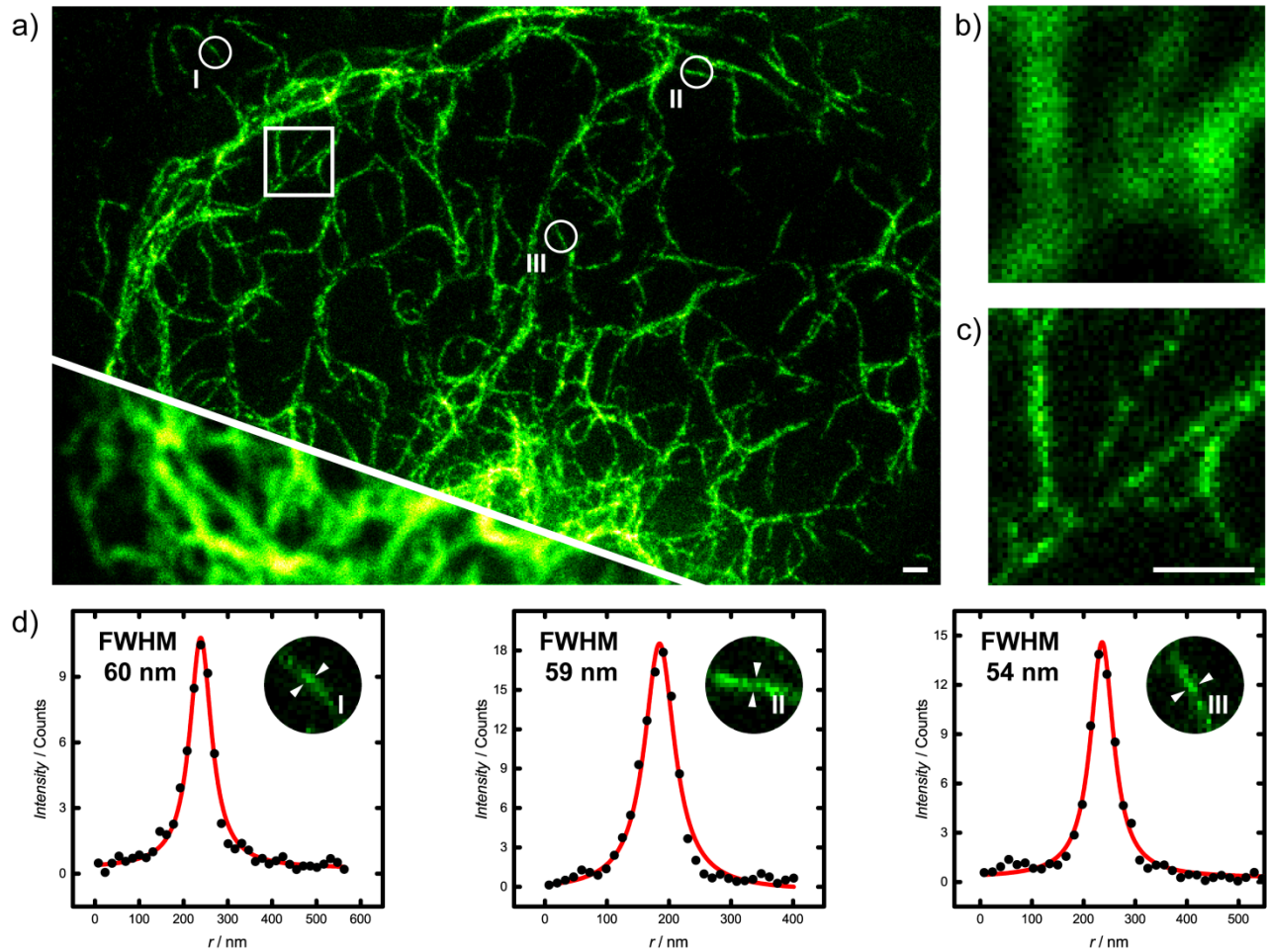

Figure S11. STED image of vimentin filaments in a living cell expressing vimentin-HaloTag fusion protein after incubation with *580R* (**1d**-Halo, 1 μ M for 20 min). (a) STED image vs. confocal in bottom left corner. (b) and (c) show zoomed views of the region marked in (a) of the confocal and STED image, respectively. (d) Panels show zoomed views and the corresponding line profiles along a line between the arrowheads, drawn perpendicular to the indicated filaments in. Positions are indicated in (a) and perspective close-ups are shown as insets. Counts were averaged over five pixels along the direction of the filament and fitted to the Lorentzian function. The spatial coordinate along the line is represented by r . Fitting with the Lorentzian function yielded the indicated full width at half maximum (FWHM) values yielding an optical resolution ≤ 60 nm. Scale bars: 500 nm. Excitation at 594 nm; pixel dwell time: 20 μ s for STED, 40 μ s for confocal; pixel size: 25 nm; For the STED image each line was scanned 3 times and counts at corresponding pixels were summed up. Figure shows raw data.

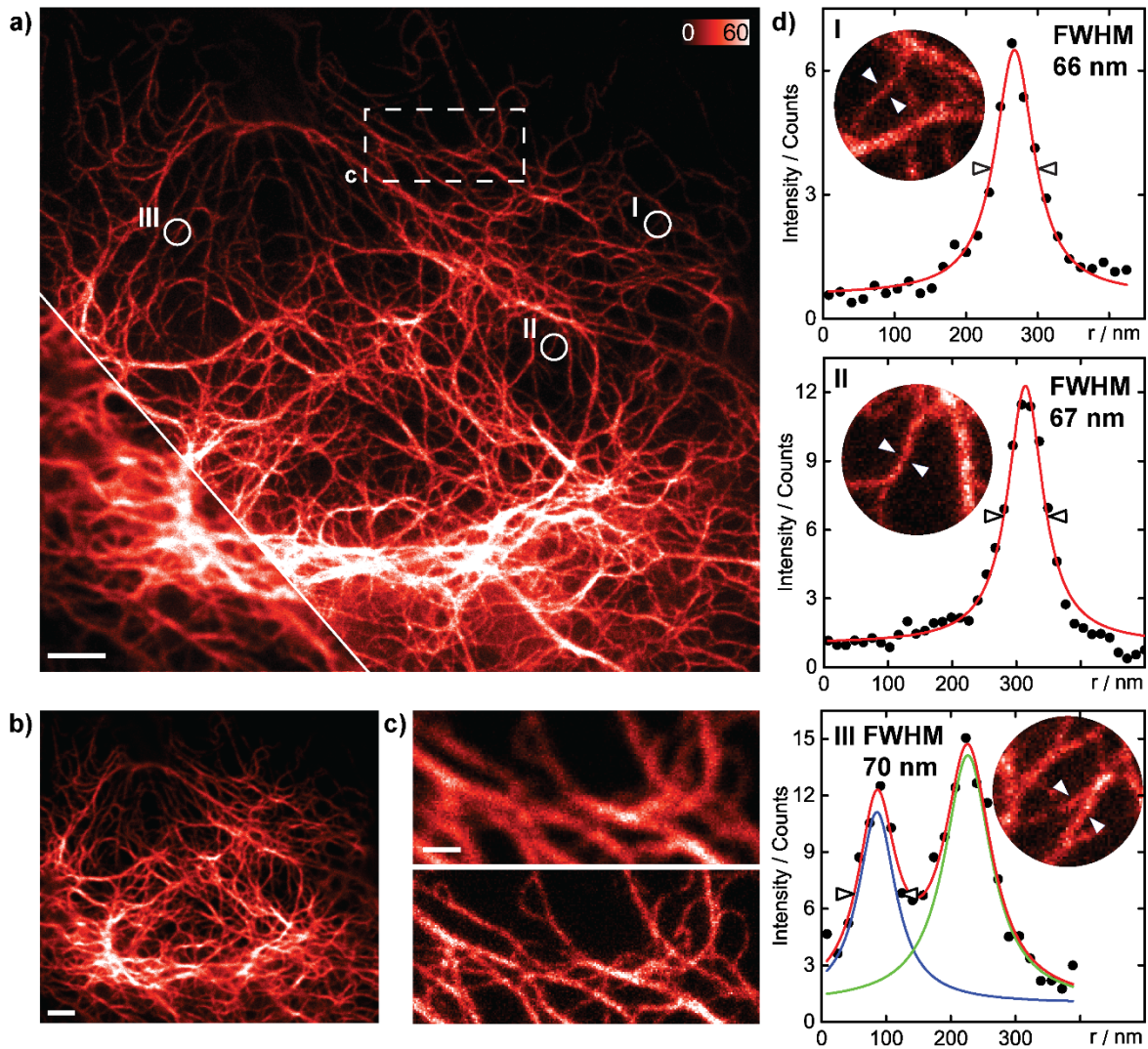

Figure S12. (a) STED image of a living HeLa cell expressing a vimentin-HaloTag fusion protein stained with *580CP* (**1e-Halo**, 1 μ M for 20 min). Confocal counterpart is shown in the lower left corner. (b) Full confocal image of the same cell. (c) Close-up views of the confocal and STED image, respectively, of the area indicated in panel (a). (d) Line profiles taken across the filaments marked by the arrows in the circular close-up views. Profiles were averaged over 4-10 pixels along the filaments and fitted to single or double Lorentzians yielding the indicated full width at half maximum values. The two filaments in subpanel III are separated by 140 nm. For the STED image each line was scanned 4 times and counts at corresponding pixels were summed up. Figure shows data slightly smoothed with a 1.0 pixel wide Gaussian. Scale bars: (a), (b) 2 μ m, (c) 500 nm.

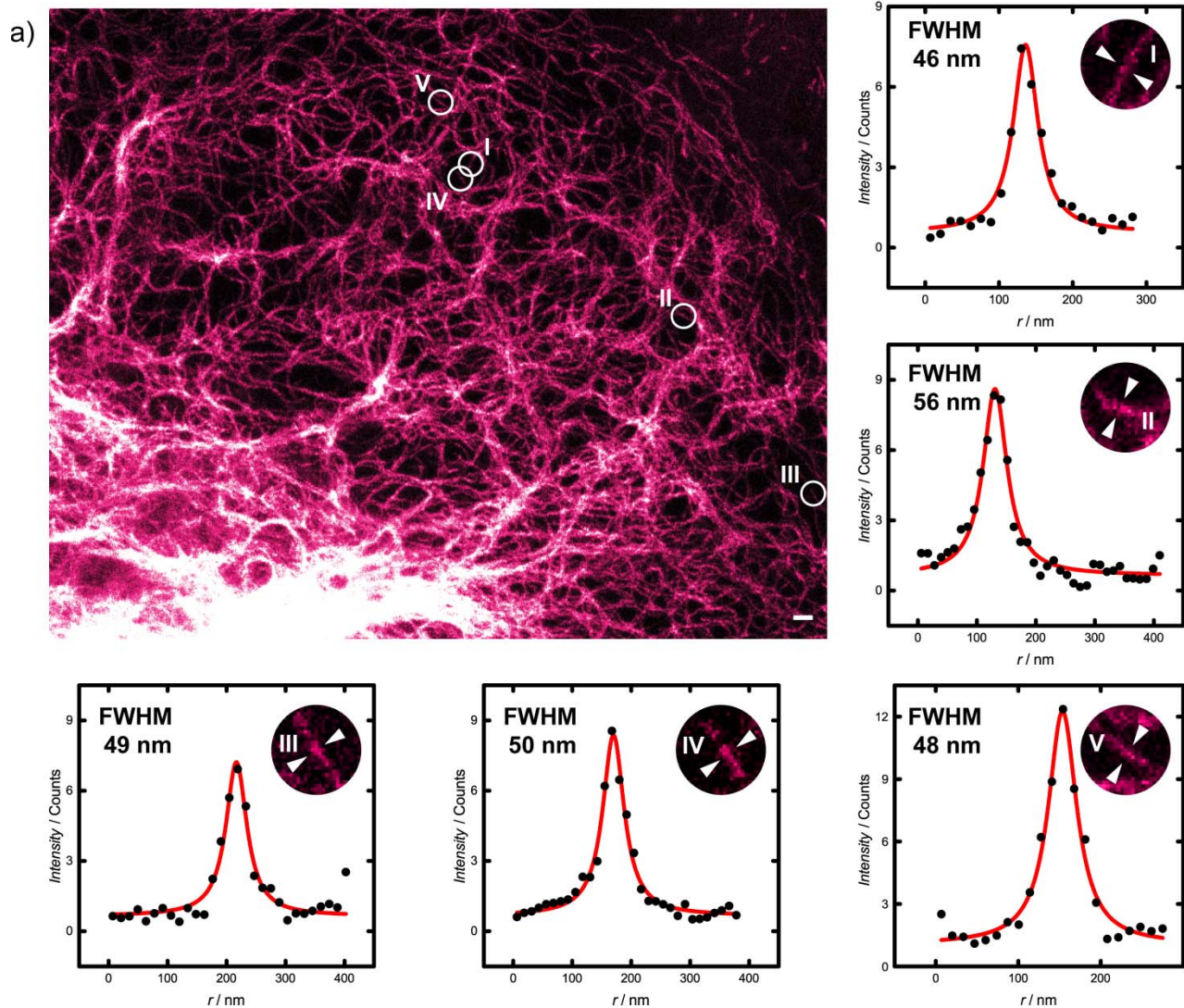

Figure S13. STED image (raw data) of vimentin filaments in a living cell expressing vimentin-HaloTag fusion protein after incubation with *610CP* (**1f**-Halo, 1 μ M for 20 min), as shown in Figure 3 in the main text. Panels show zoomed views and the corresponding line profiles drawn perpendicular to the indicated filaments. Counts were averaged over five pixels along the direction of the filament and fitted to the Lorentzian function. Resulting full-width at half maximum values are given for each fit providing an upper boundary for the optical resolution of ≤ 50 nm. Scale bar: 500 nm. Imaging parameters are written in the legend of Figure 3 in the main text.

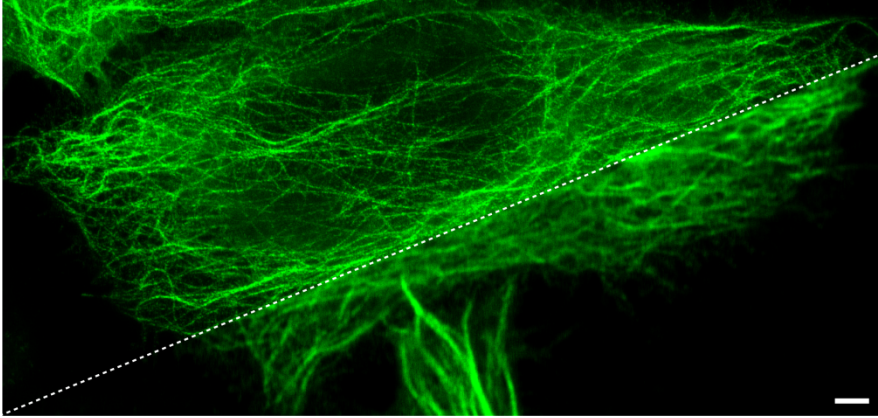

Figure S14. Comparison of a confocal (bottom) and a STED (top) image of tubulin filaments labeled with *580R* dye (**1d-Halo**, 1 μM) via HaloTag fusion in living HeLa cells. Image is displayed as raw data. Scale bar: 2 μm .

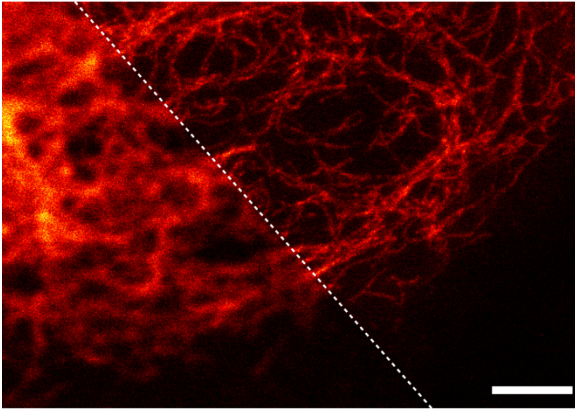

Figure S15. Comparison of a confocal (left) and a STED (right) image of vimentin filaments labeled with *620CP* dye (**1g-Halo**, 1 μM) via HaloTag fusion in living HeLa cells. Image is displayed as raw data. Scale bar: 2 μm .

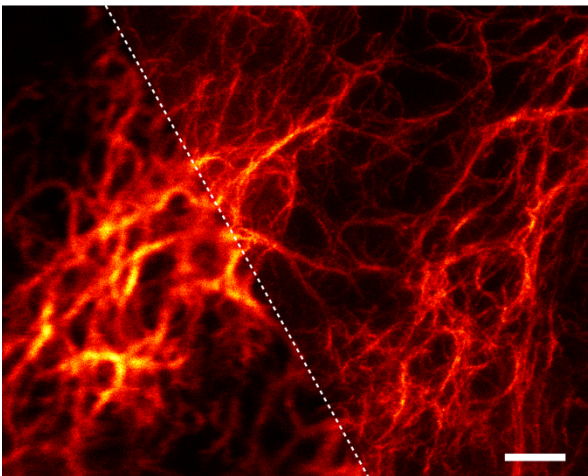

Figure S16. Comparison of a confocal (left) and a STED (right) image of vimentin filaments labeled with *650SiR* dye (**1j-Halo**, 1 μM) via HaloTag fusion in living HeLa cells. Image is displayed as raw data. Scale bar: 2 μm .

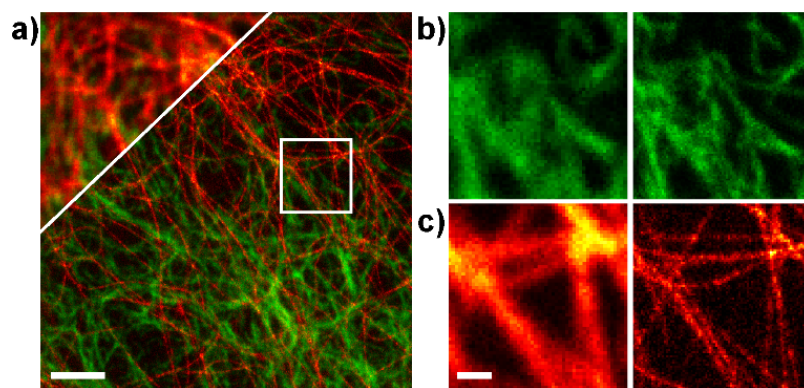

Figure S17. Two-color STED image of vimentin (green) and tubulin (red) in living HeLa cells. Vimentin filaments were labeled with *580CP* applied as **1e**-Halo (1 μM , 20 min) via HaloTag fusion protein, while endogenous tubulin was directly labeled using SiR-tubulin probe^[S3] (1 μM , 20 min). (a) STED image with confocal part in upper left corner. (b) and (c) show close-up views of the region marked in (a) of the confocal (left) and STED (right) image, respectively, of the two colors. Linear unmixing was applied to remove residual spectral crosstalk. Images were slightly smoothed with a 1.0 pixel wide Gaussian. Color channels were recorded linewise. Counts of 3 scans per line for SiR and 2 scans per line for *580CP* were accumulated. Pixel dwell time: 12 μs . Pixel size: STED: 30 nm, confocal: 50 nm. Linear unmixing was performed with the SpectralUnmixing plugin of ImageJ. The mixing matrix was generated from cells labelled with only one of the dyes. Scale bars: (a) 2 μm , (c) 500 nm.

The attainable resolution in the green channel was limited by the signal intensity in the red channel, due to higher absorption cross-section of *SiR* at 775 nm compared to *580CP*. Independent control of the STED power for the two channels would enable a better resolution for *580CP* in dual-color images.

Control experiments

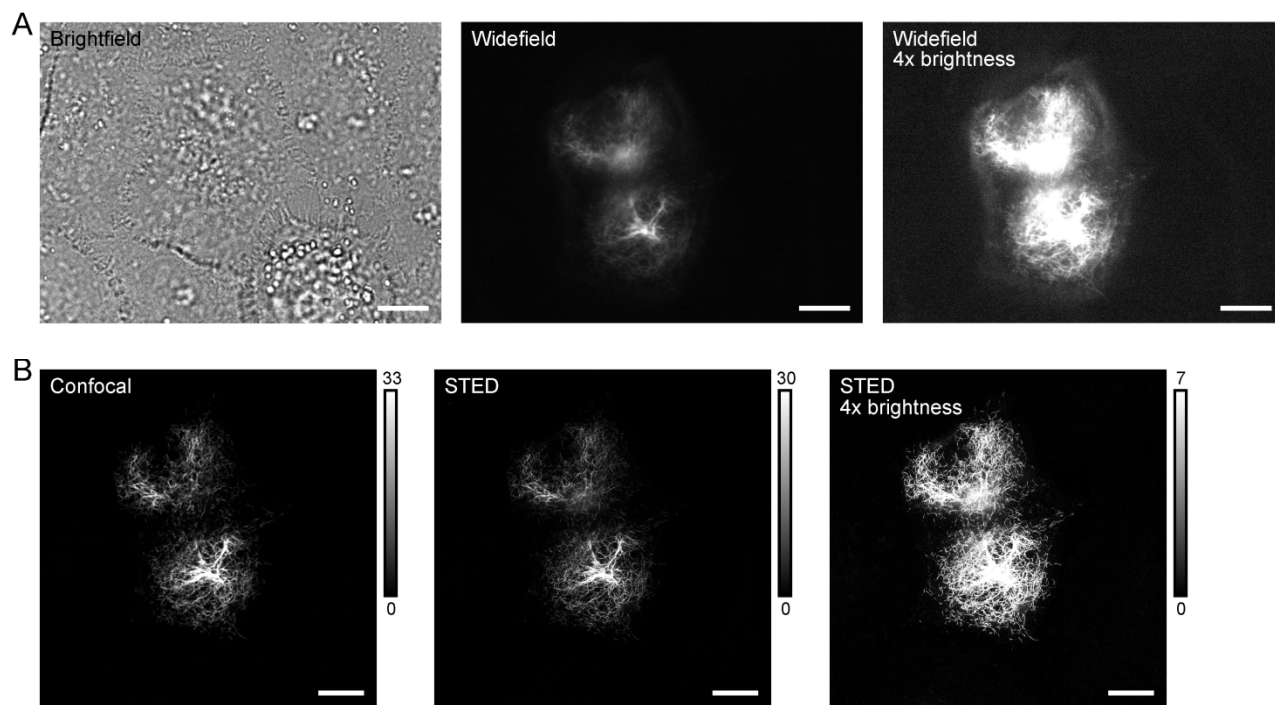

Figure S18. Non-transfected cells do not show unspecific background staining.

HeLa cells were incubated with **1e**-Halo dye for 20 min under growth conditions and imaged live with the Abberior two-color STED microscope.

- A) Left: Brightfield image showing plenty of cells growing next to each other. Middle, Right: Fluorescence widefield illumination of the same area. Only two cells, which got transfected with the vimentin-HaloTag fusion protein, exhibit specific fluorescence of **1e**-Halo while the surrounding, non-transfected cells remain dark (middle). By increasing the brightness of the image four times does not show any appearance of fluorescence background in the non-transfected cells (right). Scale bar 10 μm .
- B) Confocal and STED images of the same field of view as in (A) show no unspecific background. Increasing the brightness of the STED image four times also does not result in any appearance of unspecific background in the surrounding non-transfected cells. Scale bar 10 μm .

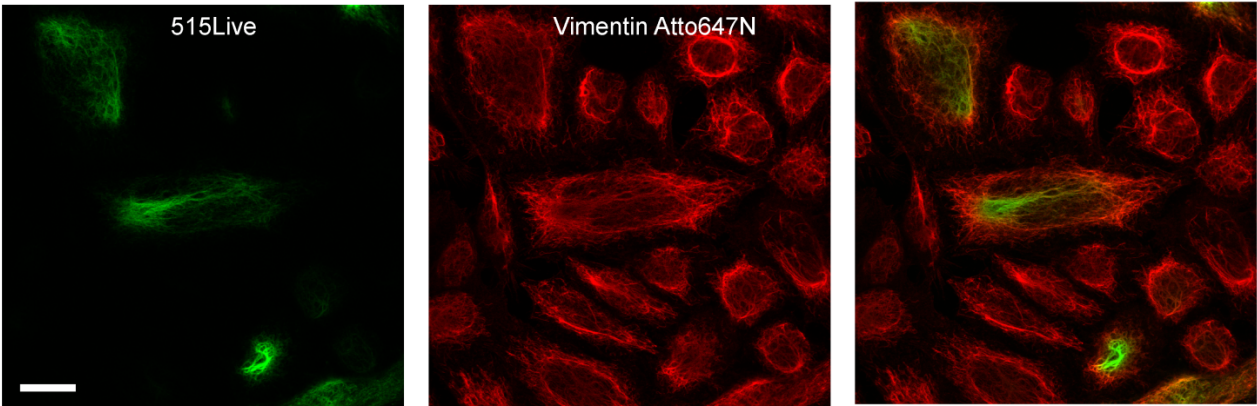

Figure S19. Specificity of the plasmid-based expression of HaloTag-labeled vimentin in HeLa cells.

Cells were incubated with **1b**-Halo dye for 20 min under growth conditions with a subsequent methanol fixation and immunostaining of endogenous vimentin with anti-vimentin antibodies plus Atto647N-coupled secondary antibody detection. Confocal images of both labels were taken sequentially using a Leica TCS SP8 microscope (Leica Microsystems GmbH, Mannheim, Germany) equipped with a 63×/1.40 OIL objective (HC PL APO CS2, Leica Microsystems GmbH). *515R* (**1b**) was excited using the Argon Laser at 514 nm, Atto647N was excited at 633 nm with a HeNe Laser. Fluorescence was detected by PMTs at 522-600 nm and 641-720 nm, respectively. While the anti-vimentin antibodies marked vimentin in all cells independent of transfection, the **1b**-Halo dye labeled only the vimentin-HaloTag fusion protein, showing that the stained filaments are indeed vimentin specific. Scale bar 20 μ m.

General experimental information and synthesis

NMR spectra were recorded at 25 °C with Agilent 400-MR spectrometer at 400.06 MHz (^1H), 376.40 MHz (^{19}F) and 100.60 MHz (^{13}C) and are reported in ppm. All ^1H spectra are referenced to tetramethylsilane ($\delta = 0$ ppm) using the signals of the residual protons of CHCl_3 (7.26 ppm) in CDCl_3 , acetone- d_5 (2.05 ppm) in acetone- d_6 , CHD_2OD (3.31 ppm) in CD_3OD or DMSO- d_5 (2.50 ppm) in DMSO- d_6 . ^{13}C spectra are referenced to tetramethylsilane ($\delta = 0$ ppm) using the signals of the solvent: CDCl_3 (77.16 ppm), acetone- d_6 (CD_3 , 29.84 ppm), CD_3OD (49.00 ppm) or DMSO- d_6 (39.52 ppm). Multiplicities of signals are described as follows: s = singlet, d = doublet, t = triplet, q = quartet, m = multiplet or overlap of non-equivalent resonances; br = broad signal. Coupling constants (J) are given in Hz.

ESI-MS were recorded on a Varian 500-MS spectrometer (Agilent). ESI-HRMS were recorded on a MICROTOF spectrometer (Bruker) equipped with ESI ion source (Apollo) and direct injector with LC autosampler Agilent RR 1200.

Liquid chromatography: HPLC was performed with Knauer Smartline liquid chromatography system: two pumps (1000), with an UV-detector 2500 with the column thermostat 4000, the mixing chamber and the injection valve with 20 and 100 μL loop for the analytical and preparative columns, respectively; 6-port-3-channel switching valve. Analytical column: Eurospher 100 C18, 5 μm , 250 \times 4 mm; preparative column: Eurospher 100 C18, 5 μm , 250 \times 8 mm; solvent A: acetonitrile + 0.1% v/v TFA, solvent B: H_2O + 0.1% v/v TFA; temperature 25 °C. Analytical TLC was performed on Merck Millipore ready-to-use plates with silica gel 60 (F₂₅₄). Preparative TLC was performed on precoated thin-layer plates with silica gel for high performance TLC (HPTLC Silica gel 60 F₂₅₄ 10 \times 10 cm, with concentrating zone 10 x 2.5 cm), purchased from Merck Millipore (Darmstadt, Germany; Cat. No. 113727). Flash chromatography was performed on Merck Millipore Silica 60 0.04–0.063 mm for column chromatography (Cat. No. 815360) or on Biotage IsoleraTM flash purification system using the type of cartridge and solvent gradient indicated. Reversed-phase chromatography was done on Polygoprep 60-50 C₁₈ from Macheray-Nagel (Düren, Germany; Cat. No. 711500).

2,2'-(2-Bromo-1,4-phenylene)bis(4,4-dimethyl-4,5-dihydrooxazole) (SI-1)^[S4]

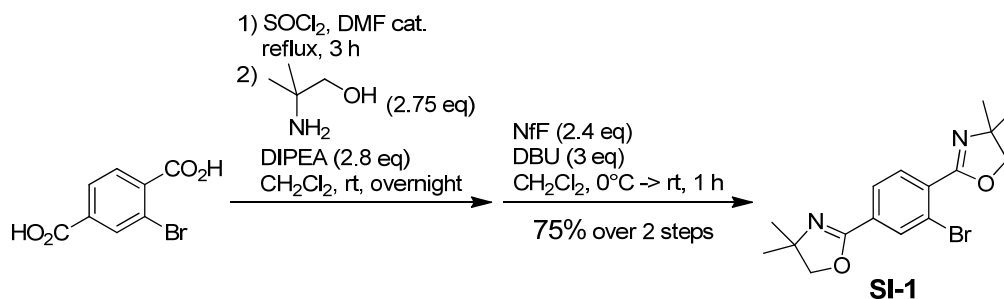

Bromoterephthalic acid (1.50 g, 6.12 mmol) was suspended in SOCl₂ (10 mL), 3 drops of DMF were added and the mixture was refluxed for 3 h. The solution was evaporated to dryness and the residue was dissolved in CH₂Cl₂. The resulting solution of acyl chloride was added dropwise to the mixture of 2-amino-2-methyl-1-propanol (1.50 g, 16.85 mmol, 2.75 equiv) and *N,N*-diisopropylethylamine (DIPEA; 3 mL, 2.23 g, 17.33 mmol, 2.8 equiv) in CH₂Cl₂ (20 mL), cooled in ice-water bath. The resulting suspension was stirred overnight at rt, quenched by addition of sat. aq. NaHCO₃ (50 mL), extracted with EtOAc (3×20 mL), the combined organic layers were washed with water, brine and dried over Na₂SO₄. Upon filtration, the solvent was evaporated to give the crude solid diamide, which was used directly in the next step.

The solid was suspended in CH₂Cl₂ (60 mL) and 1,8-diazabicyclo[5.4.0]undec-7-ene (DBU; 2.74 mL, 18.36 mmol, 3 equiv) was added to the suspension, turning it into a clear solution. The solution was cooled in ice-water bath, followed by addition of perfluoro-1-butan-1-ylsulfonyl fluoride (nonafllyl fluoride, NfF; 2.64 mL, 4.44 g, 14.69 mmol, 2.4 equiv) dropwise over 2 min. The resulting solution was stirred at rt for 1 h, quenched with sat. aq. NaHCO₃ (50 mL), extracted with CH₂Cl₂ (3×20 mL), the organic extracts were washed with brine and dried over Na₂SO₄. The product was isolated by flash column chromatography (120 g silica, gradient 50% to 100% EtOAc – CH₂Cl₂), the fractions containing the product were evaporated, the residue was redissolved in CH₂Cl₂, microfiltered through a 0.45 μm PTFE membrane filter, evaporated to dryness and crystallized from cold hexane (upon addition of a seed crystal) to give 1.62 g of the product (yield 75% over 2 steps).

¹H NMR (400 MHz, CDCl₃): δ 8.19 (d, *J* = 1.5 Hz, 1H), 7.86 (dd, *J* = 8.0, 1.5 Hz, 1H), 7.67 (d, *J* = 8.1 Hz, 1H), 4.11 (d, *J* = 7.3 Hz, 4H), 1.37 (d, *J* = 12.2 Hz, 12H).

¹³C NMR (101 MHz, CDCl₃): δ 161.2, 160.2, 133.2, 132.6, 131.13, 131.08, 126.7, 121.7, 79.43, 79.37, 68.2, 67.9, 28.3, 28.2.

ESI-MS, positive mode: *m/z* (rel. int., %) = 351.2 (100) [M+H, ⁷⁹Br]⁺.

1,1'-(2-Bromo-1,4-phenylene)bis(4-methyl-2,6,7-trioxabicyclo[2.2.2]octane) (SI-3)

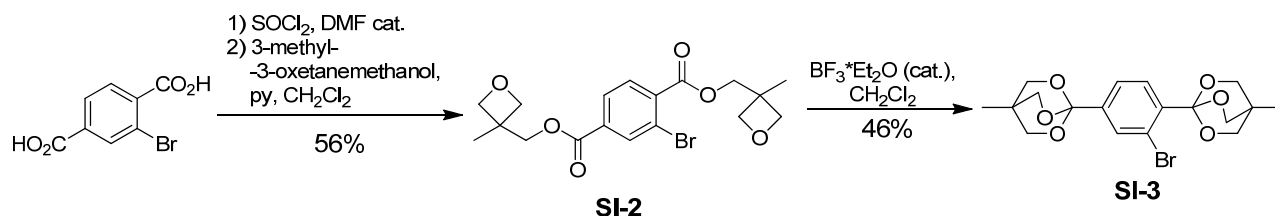

SI-2

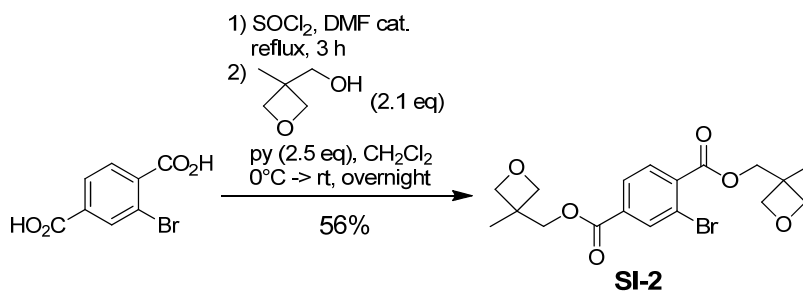

Bromoterephthalic acid (1.50 g, 6.12 mmol) was mixed with thionyl chloride (10 mL), DMF (2 drops) was added and the suspension was refluxed for 3 h (the solids dissolved within 30 min). The mixture was evaporated to dryness, re-evaporated with CH₂Cl₂, redissolved in CH₂Cl₂ (10 mL) and added dropwise to a cold (ice-water bath) solution of 3-methyl-3-oxetanemethanol (1.31 g, 12.83 mmol, 2.1 equiv) and pyridine (1.23 mL, 15.23 mmol, 2.5 equiv) in CH₂Cl₂ (20 mL). The resulting mixture was stirred in ice-water bath for 1 h and then at rt overnight. The mixture was then diluted with CH₂Cl₂, washed with sat. aq. NaHCO₃ (100 mL), water (2×100 mL) and brine, dried over Na₂SO₄. The product was isolated by flash column chromatography (30 g silica, deactivated with 2% Et₃N; gradient 50% to 100% ethyl acetate – hexane). The fractions containing the product were evaporated and dried *in vacuo*. Viscous colorless oil, yield 1.42 g (56%).

¹H NMR (400 MHz, acetone-d₆): δ 8.30 (dt, *J* = 1.6, 0.5 Hz, 1H), 8.13 (ddd, *J* = 8.0, 1.6, 0.4 Hz, 1H), 7.96 (dt, *J* = 8.1, 0.4 Hz, 1H), 4.56 (dd, *J* = 6.0, 4.0 Hz, 4H), 4.48 (d, *J* = 7.8 Hz, 4H), 4.36 (dd, *J* = 9.3, 5.9 Hz, 4H), 1.42 (s, 6H).

¹³C NMR (101 MHz, acetone-d₆): δ 166.3, 164.9, 137.9, 135.4, 134.8, 132.1, 129.3, 121.2, 79.6, 71.0, 70.6, 40.1, 40.0, 21.4, 21.3.

ESI-MS, positive mode: *m/z* (rel. int., %) = 415.3 (100) [M+H, ⁸¹Br]⁺.

HR-MS (ESI, positive mode): 413.0581 [M+H, ⁷⁹Br]⁺ (found), 413.0594 (calculated for C₁₈H₂₂BrO₆, [M+H, ⁷⁹Br]⁺).

SI-3

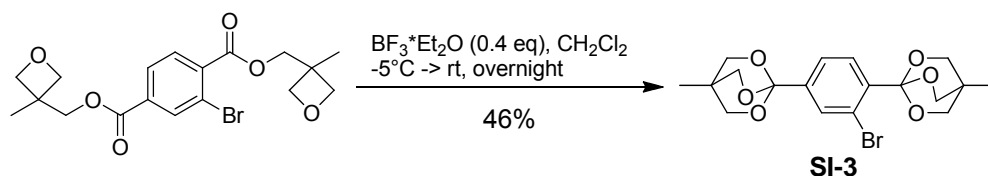

Boron trifluoride etherate (160 μ L, 1.29 mmol, 0.4 equiv) was added dropwise to a solution of ester **SI-2** (1.33 g, 3.22 mmol) in CH₂Cl₂ (6 mL), cooled in ice-salt bath (bath temperature -5 °C). The mixture was stirred at -5 °C for 1 h and then at rt overnight. Triethylamine (450 μ L, 3.22 mmol, 1 equiv) was added, and the mixture was stirred at rt for 2 h. The mixture, containing viscous precipitate, was diluted with diethyl ether (10 mL) and CH₂Cl₂ (5 mL) and stirred for further 30 min. The resulting suspension was filtered through a short plug of Celite, washed with diethyl ether-CH₂Cl₂ (1:1), the filtrate was evaporated and the product was isolated by flash column chromatography (40 g silica, deactivated with 2% Et₃N; gradient 25% to 100% ethyl acetate – hexane). Fractions containing the product were evaporated to a white solid, which was dried in vacuo to give 606 mg (46%) of the product.

¹H NMR (400 MHz, acetone-d₆): δ 7.76 (d, J = 1.7 Hz, 1H), 7.70 (d, J = 8.2 Hz, 1H), 7.48 (dd, J = 8.2, 1.7 Hz, 1H), 4.05 (s, 6H), 4.04 (s, 6H), 0.90 (s, 3H), 0.89 (s, 3H).

¹³C NMR (101 MHz, acetone-d₆): δ 141.4, 137.9, 132.9, 128.3, 124.9, 121.0, 107.5, 107.2, 73.7, 73.3, 31.2, 31.1, 14.3, 14.2.

ESI-MS, positive mode: m/z (rel. int., %) = 413.2 (100) [M+H, ⁷⁹Br]⁺.

HR-MS (ESI, positive mode): 413.0592 [M+H, ⁷⁹Br]⁺ (found), 413.0594 (calculated for C₁₈H₂₂BrO₆, [M+H, ⁷⁹Br]⁺).

Fluorescent dye **500R** (**1a**)

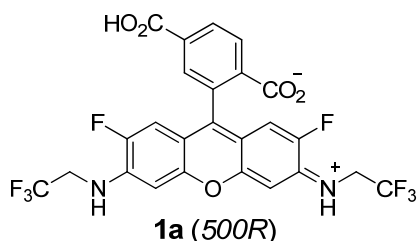

The dye **1a** (**500R**) was prepared according to the reported procedure.^[S5] The tagged derivative **1a**-Halo was prepared as follows:

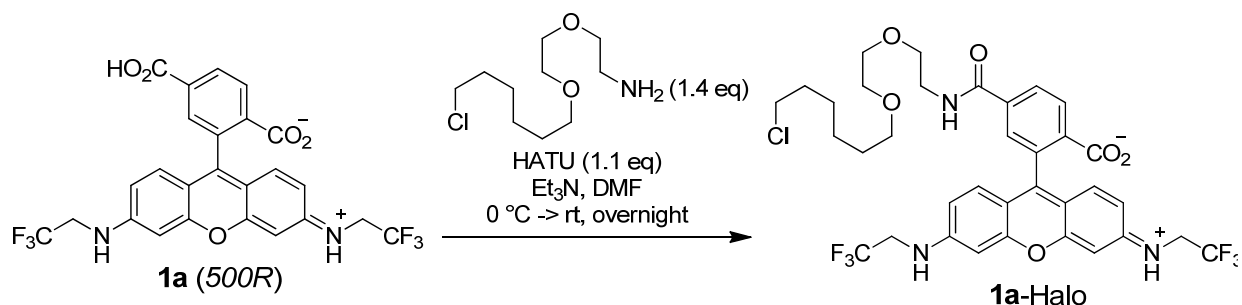

HaloTag Amine (O2) hydrochloride (2-[2-(6-chlorohexyloxy)ethoxy]ethylammonium hydrochloride,^[S6] 23 mg, 100 μ mol) in 1 mL of dry DMF was added to isomerically pure 6'-carboxy-*N,N'*-bis(2,2,2-trifluoroethyl)rhodamine (**1a**; 30 mg, 70 μ mol), followed by addition of triethylamine (20 μ L, 140 μ mol). After the reaction mixture was cooled down to 0 $^{\circ}$ C, HATU (1-[bis(dimethylamino)methylene]-1*H*-1,2,3-triazolo[4,5-*b*]pyridinium 3-oxid hexafluorophosphate; 30 mg, 79 μ mol) was added. The mixture was stirred at rt overnight under argon atmosphere. The solvent was removed *in vacuo*, and the product was isolated by column chromatography (25 g silica, CHCl₃/MeOH/H₂O 86:13:1). Bright red-orange solid, yield 10 mg (19%).

HPLC (1.2 mL/min, gradient A:B = 20:80 \rightarrow 50:50 over 25 min, detection at 254 nm): *t* = 10.5 min.

ESI-MS, positive mode: *m/z* (rel. int., %) = 744.2 (100) [M+H]⁺.

¹H NMR (400 MHz, DMSO-*d*₆): δ 8.73 (t, *J* = 5.6 Hz, 1H), 8.14 (dd, *J* = 8.1, 1.4 Hz, 1H), 8.03 (dd, *J* = 8.1, 0.7 Hz, 1H), 7.67 (t, *J* = 1.1 Hz, 1H), 6.75 (t, *J* = 6.8 Hz, 2H), 6.63 (d, *J* = 2.2 Hz, 2H), 6.45 (t, *J* = 8.5 Hz, 2H), 3.98 (p, *J* = 9.2 Hz, 4H), 3.57 (t, *J* = 6.6 Hz, 2H), 3.49 – 3.42 (m, 4H), 3.42 – 3.37 (m, 2H), 3.31 (s, 6H), 3.28 (t, *J* = 6.5 Hz, 2H), 1.64 (dt, *J* = 14.4, 6.7 Hz, 2H), 1.43 – 1.34 (m, 2H), 1.34 – 1.25 (m, 1H), 1.26 – 1.16 (m, 2H).

¹³C NMR (101 MHz, DMSO-*d*₆): δ 168.6, 165.0, 153.1, 152.6, 150.4, 140.9, 130.4, 129.7, 129.1, 129.0, 127.6, 125.1, 124.8, 122.7, 110.6, 107.2, 98.3, 84.8, 70.5, 70.0, 69.8, 69.0, 45.8, 44.06 (q, *J* = 32.2 Hz), 40.6, 40.4, 40.2, 40.0, 39.9, 39.8, 39.6, 39.3, 32.4, 29.4, 26.5, 25.3.

HR-MS (ESI, positive mode): 744.2263 [M+H]⁺ (found), 744.2270 (calculated for C₃₅H₃₇ClF₆N₃O₆, [M+H]⁺).

Gradient : A% = 30 B% = 70 ----> A% = 100 B% = 0 T = 20 Min.

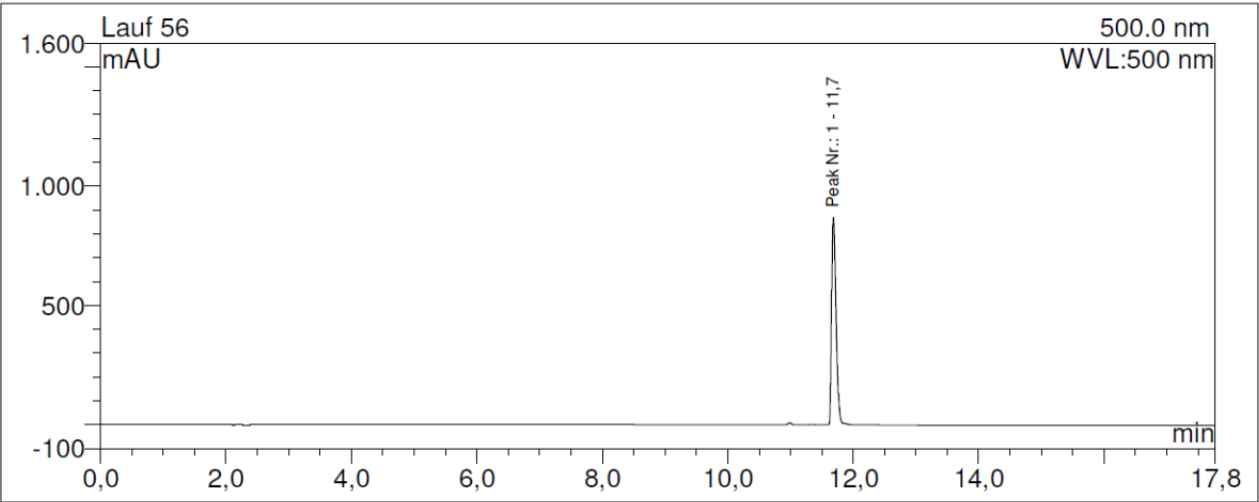

Fluorescent dye **1b** (**515R**)

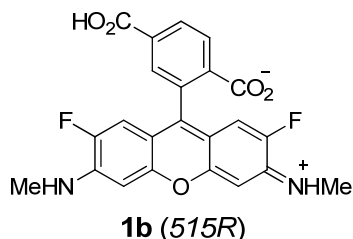

The dye **1b** (**515R**) was prepared according to the reported procedure.^[S5] The tagged derivative **1b**-Halo was prepared as follows:

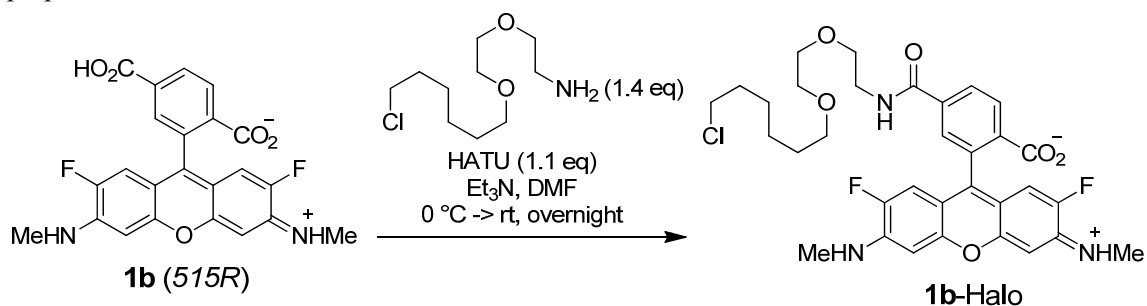

HaloTag Amine (O2) hydrochloride (2-[2-(6-chlorohexyloxy)ethoxy]ethylammonium hydrochloride;^[S6] 1.4 mg, 6.3 μmol) in 0.2 mL of dry DMF was added to isomerically pure 6'-carboxy-2,7-difluoro-*N,N'*-dimethylrhodamine (**1b**; 2.0 mg, 4.6 μmol), followed by addition of triethylamine (5 μL , 35 μmol). After the reaction mixture was cooled down to 0 $^\circ\text{C}$, HATU (1-[bis(dimethylamino)methylene]-1*H*-1,2,3-triazolo[4,5-*b*]pyridinium 3-oxid hexafluorophosphate; 2.0 mg, 5.2 μmol) was added. The mixture was stirred at rt overnight under argon atmosphere. The solvent was removed *in vacuo*, and the product was isolated by column chromatography (10 g silica, $\text{CHCl}_3/\text{MeOH}/\text{H}_2\text{O}$ 60:40:3). Bright red solid, yield 0.6 mg (20%).

HPLC (1.2 mL/min, gradient A:B = 30:70 \rightarrow 100:0 over 25 min, detection at 254 nm): $t = 10.9$ min.

ESI-MS, positive mode: m/z (rel. int., %) = 644 (100) $[\text{M}+\text{H}]^+$.

^1H NMR (400 MHz, CD_3OD): δ 8.39 (d, $^3J_{\text{H,H}} = 8.2$ Hz, 1H, H-4'), 8.20 (dd, $^3J_{\text{H,H}} = 8.2$, $^4J_{\text{H,H}} = 1.8$, 1H, H-5'), 7.78 (d, $^4J_{\text{H,H}} = 1.8$ Hz, 1H, H-7'), 7.07 (d, $^4J_{\text{H,F}} = 6.9$, 2H, H-4/5), 6.84 (d, $^3J_{\text{H,F}} = 11.5$, 2H, H-1/8), 3.67 – 3.39 (m, 15H, CH_2 , NH), 3.10 (s, 6H, CH_3), 1.72 – 1.65 (m, 2H, CH_2), 1.47 – 1.25 (m, 6H, CH_2).

^{13}C NMR (126 MHz, DMSO): δ 167.8, 164.7, 152.0, 148.5, 147.2 (d, $J = 237.0$ Hz), 140.6, 140.5 (d, $J = 12.4$ Hz), 129.4, 128.4, 124.9, 122.1, 111.5 (d, $J = 20.5$ Hz), 102.6 (d, $J = 6.3$ Hz), 97.3 (d, $J = 4.1$ Hz), 84.3, 70.0, 69.5, 69.3, 68.6, 45.2, 31.9, 29.3, 28.9, 26.0, 24.8.

HR-MS (ESI, positive mode): 644.2343 $[\text{M}+\text{H}]^+$ (found), 644.2333 (calculated for $\text{C}_{33}\text{H}_{37}\text{ClF}_2\text{N}_3\text{O}_6$, $[\text{M}+\text{H}]^+$).

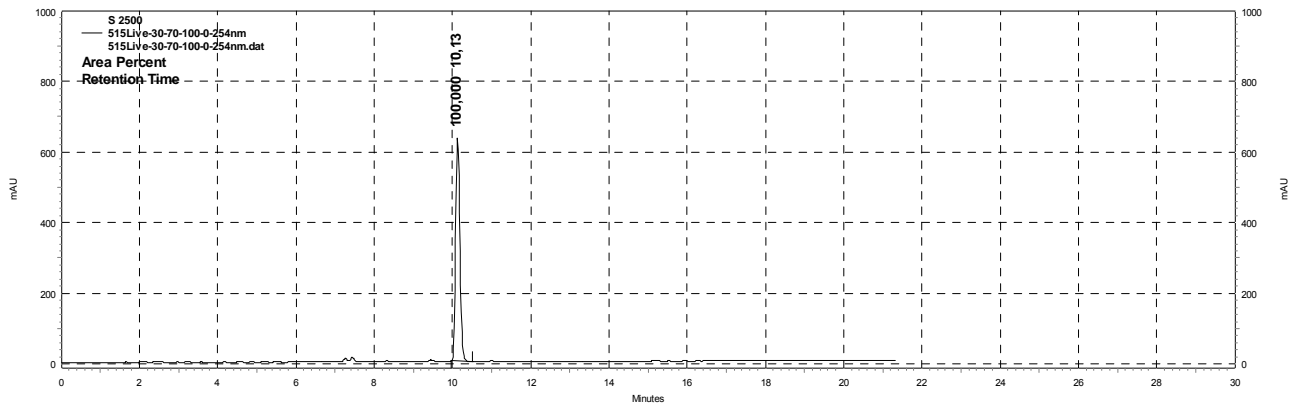

Fluorescent dye 520R (1c)

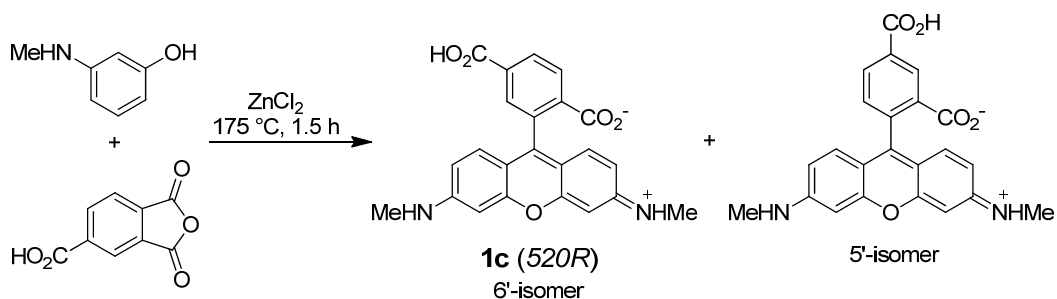

A mixture of powdered trimellitic anhydride (124 mg, 0.65 mmol) and 3-methylaminophenol (127 mg, 1.00 mmol) was heated with stirring under argon to 140 °C until it melted. ZnCl₂ (0.50 g, 3.68 mmol) was then added, and the mixture was heated at 175 °C for 1.5 h. After cooling to room temperature, water (5 mL) was added, and the solution was seeded with powdered title compound. The red solid was filtered off and the two isomers were separated by chromatography on reversed phase (50 g RP-C₁₈, gradient 1:9 → 2:3 acetonitrile – H₂O + 0.1% TFA), yielding 19 mg (9%) of 6'-isomer (**1c**, 520R) and 20 mg (10%) of 5'-isomer.

HPLC (1.2 mL/min, gradient A:B = 30:70 → 100:0 over 25 min, detection at 500 nm): t = 5.53 min (6'-isomer), 6.45 min (5'-isomer).

5'-isomer: ¹H NMR (400 MHz, DMSO-*d*₆): δ 13.45 (s, 2H, NH), 8.62 (s, 1H, H-4'), 8.30 (dd, ³J_{H,H} = 7.9, 1.7 Hz, 1H, H-6'), 7.51 (d, ³J_{H,H} = 7.9 Hz, 1H, H-7'), 6.85 (m, 2H, H-xanthene), 6.71 (m, 4H, H-xanthene), 2.89 (s, 6H, NCH₃).

6' isomer (1c, 520R): ¹H NMR (500 MHz, CD₃OD): δ 8.12 (dd, ³J_{H,H} = 8.0 Hz, ⁴J_{H,H} = 1.7 Hz, 1H, H-5'), 8.01 (d, ⁴J_{H,H} = 1.7 Hz, 1H, H-7'), 7.90 (d, ³J_{H,H} = 8.1 Hz, 1H, H-4'), 7.12 (d, ³J_{H,H} = 9.3 Hz, 2H, H-1/8), 6.68 (dd, ³J_{H,H} = 9.2 Hz, ⁴J_{H,H} = 2.3 Hz, 2H, H-2/7), 6.52 (d, ⁴J_{H,H} = 2.3, 2H, H-4/5), 2.87 (s, 6H, NCH₃).

¹³C NMR (101 MHz, D₂O): δ 174.2, 173.9, 158.5, 142.1, 137.6, 131.1, 130.4, 128.6, 126.6, 113.6, 29.2 (not all signals are resolved).

HR-MS (ESI, positive mode): 403.1288 [M+H]⁺ (found), 403.1288 (calculated for C₂₃H₁₉N₂O₅, [M+H]⁺).

The tagged derivative **1c-Halo** was prepared as follows:

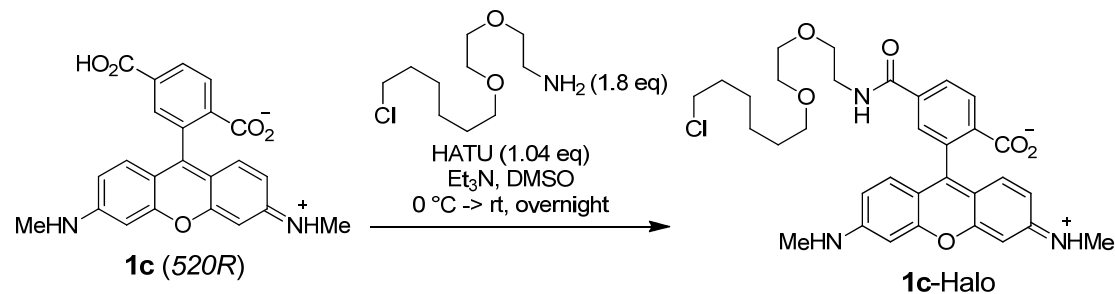

HaloTag Amine (O2) hydrochloride (2-[2-(6-chlorohexyloxy)ethoxy]ethylammonium hydrochloride;^[S6] 2.0 mg, 9.0 μmol) in dry DMF (0.2 mL) was added to isomerically pure 6'-carboxy-N,N'-dimethylrhodamine (**1c**; 2.0 mg, 5.0 μmol) in DMSO (0.3 mL), followed by addition of triethylamine (5 μL, 35 μmol). After the reaction mixture was cooled down to 0 °C, HATU (2.0 mg, 5.2 μmol) was added. The mixture was stirred at

rt overnight under argon atmosphere. The solvent was removed *in vacuo*, and the product was isolated by column chromatography (10 g silica, CHCl₃/MeOH/H₂O 65:35:5). Yield 0.5 mg (16%) of bright red solid.

HPLC (1.2 mL/min, gradient A:B = 30:70 → 100:0 over 25 min, detection at 254 nm): t = 11.4 min.

¹H NMR (500 MHz, CD₃OD): δ 8.13 (dd, *J* = 8.1, 1.7 Hz, 1H), 8.02 (d, *J* = 1.7 Hz, 1H), 7.91 (d, *J* = 8.1 Hz, 1H), 7.13 (d, *J* = 9.3 Hz, 2H), 6.69 (dd, *J* = 9.2, 2.2 Hz, 2H), 6.53 (d, *J* = 2.3 Hz, 2H), 2.88 (s, 6H).

¹³C NMR (126 MHz, CD₃OD): δ 174.1, 159.3, 141.9, 137.5, 130.8, 130.2, 128.8, 113.4, 29.1 (indirect detection from HMBC experiment; only H-coupled carbons are resolved).

ESI-MS, positive mode: *m/z* (rel. int., %) = 608.3 (100) [M+H]⁺.

HR-MS (ESI, positive mode): 608.2526 [M+H]⁺ (found), 608.2522 (calculated for C₃₃H₃₉ClN₃O₆, [M+H]⁺).

Gradient : A% = 30 B% = 70 ----> A% = 100 B% = 0 T = 20 Min.

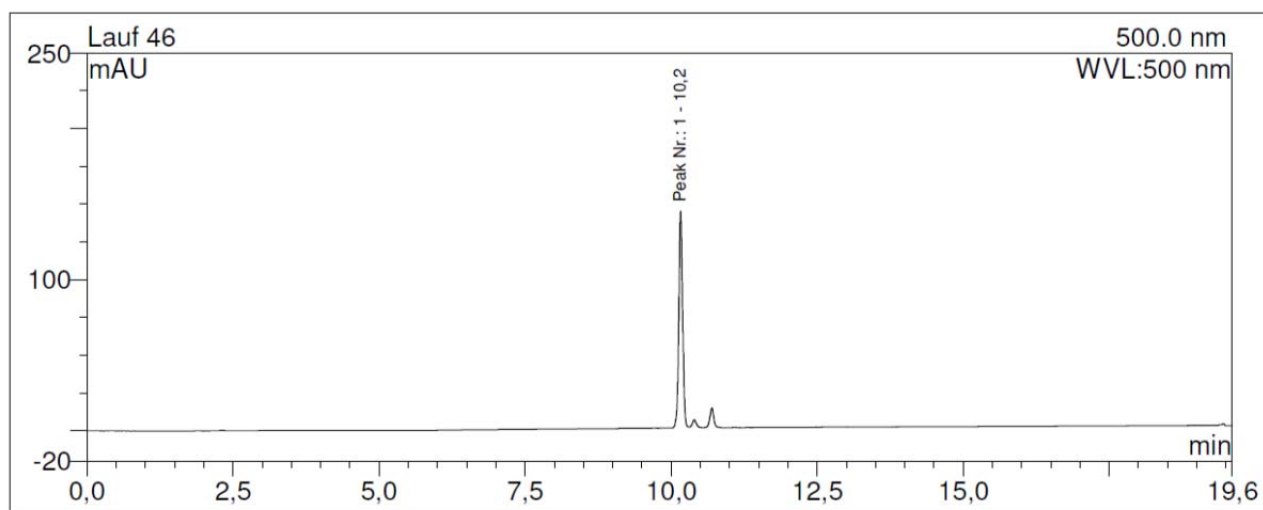

Fluorescent dye 580R (1d)

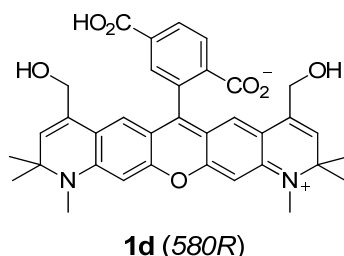

The dye **1d (580R)** was prepared according to the reported procedure.^[S7] The tagged derivative **1d-Halo** was prepared as follows:

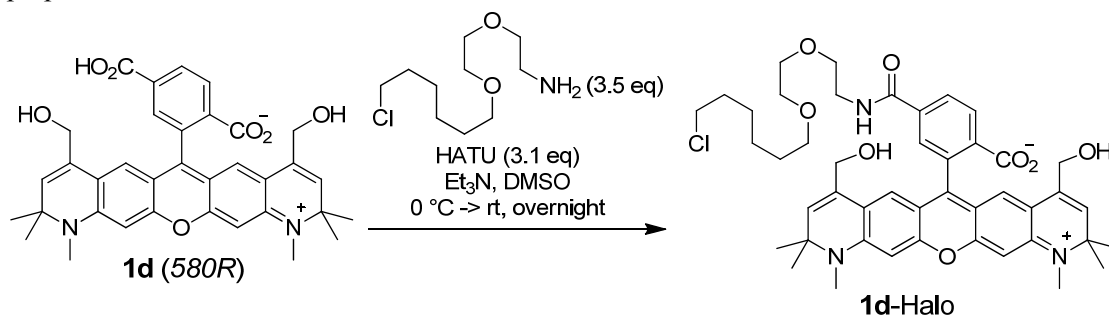

HaloTag Amine (O2) hydrochloride (2-[2-(6-chlorohexyloxy)ethoxy]ethylammonium hydrochloride,^[S6] 4.0 mg, 17.9 μmol) in dry DMSO (0.1 mL) was added to isomerically pure 6'-carboxyrhodamine 580R (**1d**; 3.0 mg, 5.1 μmol) in DMSO (0.3 mL), followed by addition of triethylamine (5 μL , 35 μmol). After the reaction mixture was cooled down to 0 $^\circ\text{C}$, HATU (6.0 mg, 15.8 μmol) was added. The mixture was stirred at rt overnight under argon atmosphere. The volatiles were removed *in vacuo*, and the product was isolated by column chromatography (100 g silica, $\text{CHCl}_3/\text{MeOH}/\text{H}_2\text{O}$ 80:18:2) and further purified by preparative HPLC. Yield 0.3 mg (7.5%) of bright purple solid.

HPLC (1.2 mL/min, gradient A:B = 30:70 \rightarrow 100:0 over 25 min, detection at 254 nm): $t = 12.8$ min.

$^1\text{H NMR}$ (400 MHz, $\text{DMSO-}d_6$): δ 8.76 (t, $J = 5.6$ Hz, 1H), 8.13 (dd, $J = 8.0, 1.3$ Hz, 1H), 8.03 (dd, $J = 8.0, 0.7$ Hz, 1H), 7.63 (dd, $J = 1.3, 0.7$ Hz, 1H), 6.30 (s, 2H), 6.27 (s, 2H), 5.44 (s, 2H), 4.72 (t, $J = 4.5$ Hz, 2H), 3.84 (dd, $J = 13.6, 4.0$ Hz, 2H), 3.77 (dd, $J = 13.6, 4.0$ Hz, 2H), 3.57 (t, $J = 6.6$ Hz, 2H), 3.46 (td, $J = 5.6, 5.0, 3.6$ Hz, 4H), 3.39 (dt, $J = 6.2, 2.9$ Hz, 2H), 3.27 (t, $J = 6.5$ Hz, 2H), 2.80 (s, 6H), 1.71 – 1.59 (m, 2H), 1.45 – 1.18 (m, 6H), 1.28 (s, 6H), 1.27 (s, 6H).

$^{13}\text{C NMR}$ (101 MHz, $\text{DMSO-}d_6$): δ 129.6, 128.7, 125.1, 122.8, 121.6, 97.1, 70.5, 69.9, 69.0, 60.7, 45.8, 40.3, 40.2, 39.5, 32.4, 31.4, 29.4, 28.3, 26.5, 25.3 (indirect detection from HSQC experiment; only H-coupled carbons are resolved).

ESI-MS, positive mode: m/z (rel. int., %) = 800 (100) $[\text{M}+\text{H}]^+$.

HR-MS (ESI, positive mode): 800.3669 $[\text{M}+\text{H}, ^{35}\text{Cl}]^+$ (found), 800.3672 (calculated for $\text{C}_{45}\text{H}_{55}\text{ClN}_3\text{O}_8$, $[\text{M}+\text{H}, ^{35}\text{Cl}]^+$).

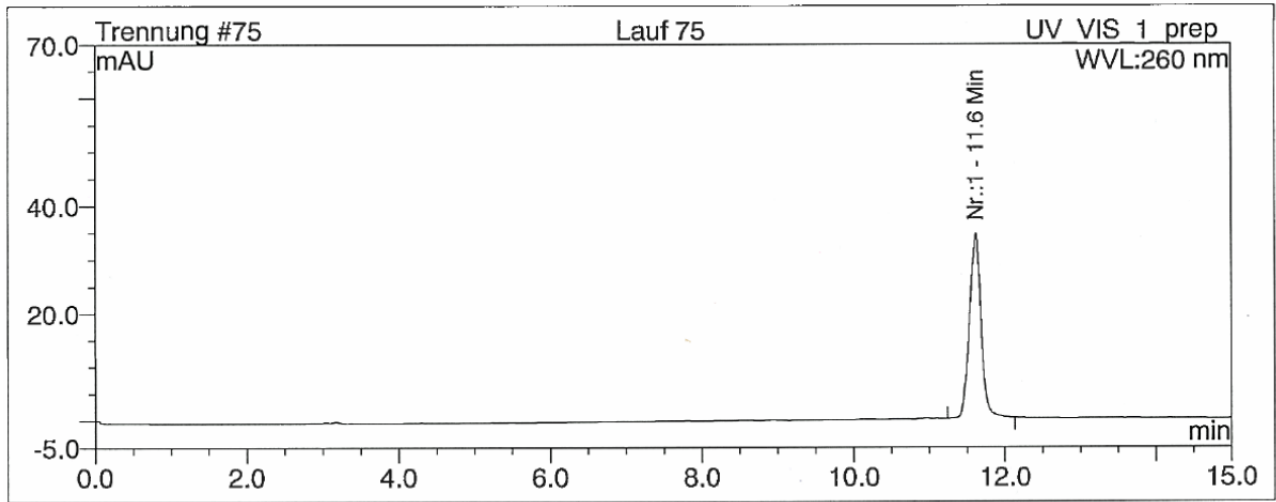

Fluorescent dye 580CP (1e)

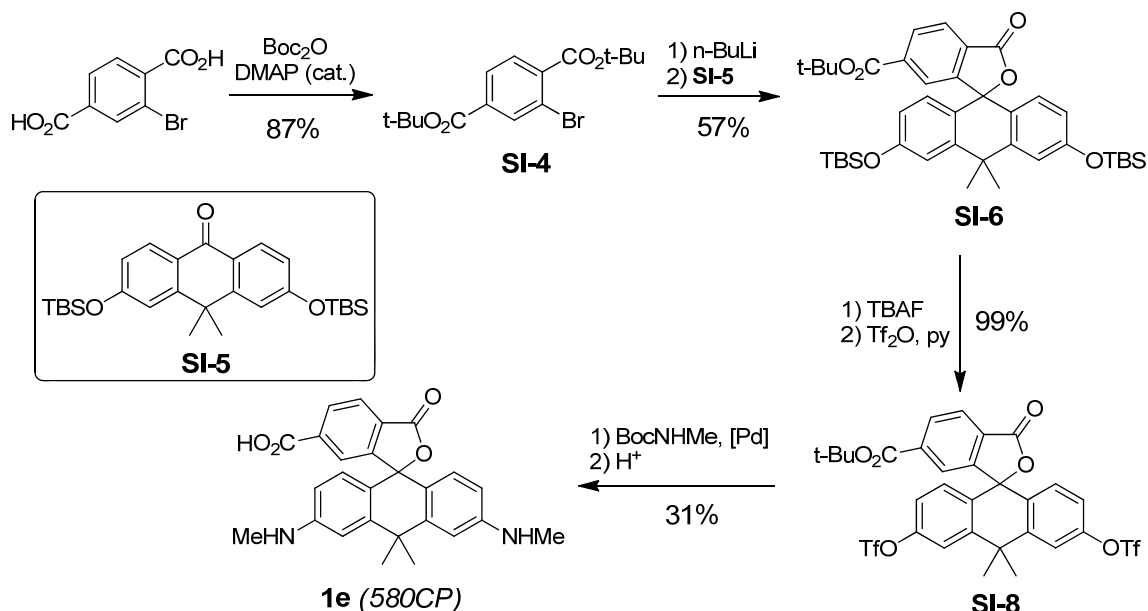

Di-tert-butyl 2-bromoterephthalate (SI-4)^[S8]

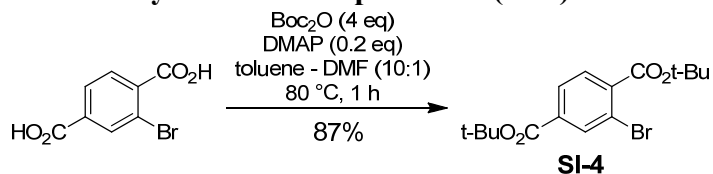

In a 100 mL round-bottom flask, equipped with a reflux condenser and bubbler, bromoterephthalic acid (2 g, 8.16 mmol) and 4-(dimethylamino)pyridine (DMAP; 199 mg, 1.63 mmol, 0.2 equiv) were mixed with DMF (2 mL). Di-tert-butyl dicarbonate (Boc_2O ; 5.34 g, 24.48 mmol, 3 equiv) was dissolved in toluene (20 mL) and added in one portion. The resulting suspension was stirred at 80°C (bath temperature) for 30 min. TLC (silica/10% ethyl acetate – hexane) showed incomplete conversion, so another portion of Boc_2O (1.78 g, 8.16 mmol, 1 equiv) in toluene (7 mL) was added, and the heating resumed for further 30 min. A turbid solution with a small amount of viscous brown precipitate eventually formed. Upon cooling to rt, sat. aq. NaHCO_3 (40 mL) was added, the mixture was extracted with ethyl acetate – hexane (2:1, 3×30 mL), the combined organic layers were washed with water (2×30 mL), brine and dried over Na_2SO_4 . The product was isolated by flash column chromatography (Biotage SNAP KP-Sil 50 g; gradient 0% to 20% ethyl acetate – hexane). The fractions containing the product were evaporated and dried on a rotavapor (bath temperature 55°C) to ensure residual Boc_2O content $\leq 5\%$ (NMR). Yield 2.53 g (87%), viscous colorless oil.

^1H NMR (400 MHz, CDCl_3): δ 8.19 (d, $J = 1.6$ Hz, 1H), 7.92 (dd, $J = 8.0, 1.6$ Hz, 1H), 7.67 (d, $J = 8.1$ Hz, 1H), 1.61 (s, 9H), 1.59 (s, 9H).

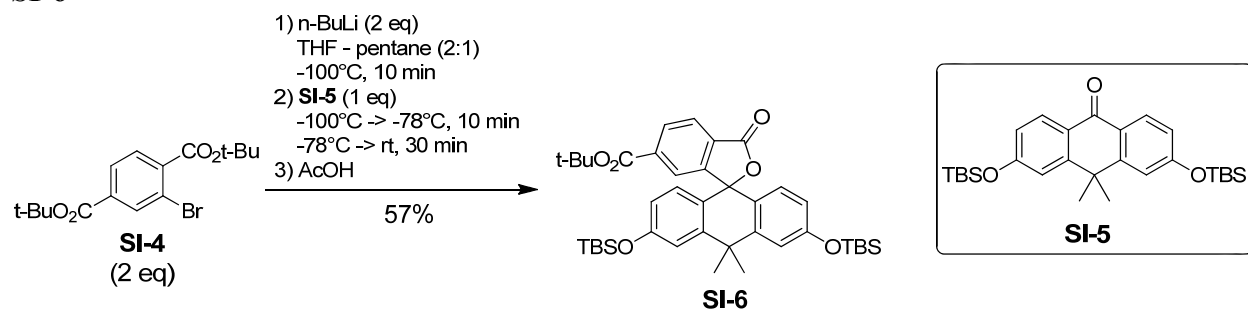
SI-6

In a 100 mL round-bottom flask, a degassed solution of **SI-4** (2.53 g, 7.09 mmol, 2 equiv) in anhydrous THF (20 mL) and pentane (10 mL) was cooled to -100 °C (bath temperature, diethyl ether – liquid N₂). *n*-Butyllithium (2.9 mL of 2.5 M solution in hexanes, ~7.1 mmol, 2 equiv) was carefully introduced through a needle along the wall of the flask. Clear solution quickly turned orange and then dark purple; it was stirred at -100 °C for 10 min, and the solution of ketone **SI-5**^[S9] in THF (10 mL) was injected over 1-2 min along the wall of the flask. The flask was then placed into a -78° bath (dry ice – acetone) and the purple solution was stirred for 10 min. The cooling bath was removed, the mixture was allowed to warm up to rt and stirred for further 30 min. The reaction mixture was quenched with water (10 mL), adjusted to pH ~ 5 with acetic acid, extracted with ethyl acetate (3×30 mL), the combined organic layers were washed with brine and dried over Na₂SO₄. The product was isolated by flash column chromatography (Biotage SNAP Ultra 100 g; gradient 0% to 20% ethyl acetate – hexane) as white solid, yield 1.38 g (57%).

¹H NMR (400 MHz, CDCl₃): δ 8.16 (dd, *J* = 8.0, 1.3 Hz, 1H), 8.03 (dd, *J* = 8.0, 0.7 Hz, 1H), 7.62 (dd, *J* = 1.4, 0.8 Hz, 1H), 7.08 (dd, *J* = 1.9, 1.0 Hz, 2H), 6.64 – 6.58 (m, 4H), 1.81 (s, 3H), 1.72 (s, 3H), 1.54 (s, 9H), 0.99 (s, 18H), 0.22 (s, 12H).

¹³C NMR (101 MHz, CDCl₃): δ 169.9, 164.4, 156.5, 155.5, 147.0, 138.1, 130.3, 129.6, 129.3, 125.1, 125.0, 124.0, 119.2, 117.8, 87.0, 82.5, 38.2, 35.0, 33.1, 28.2, 25.8, 18.4, -4.18, -4.20.

ESI-MS, positive mode: *m/z* (rel. int., %) = 687.7 [M+H]⁺.

HR-MS (ESI, positive mode): 687.3529 [M+H]⁺ (found), 687.3532 (calculated for C₄₀H₅₅O₆Si₂, [M+H]⁺).

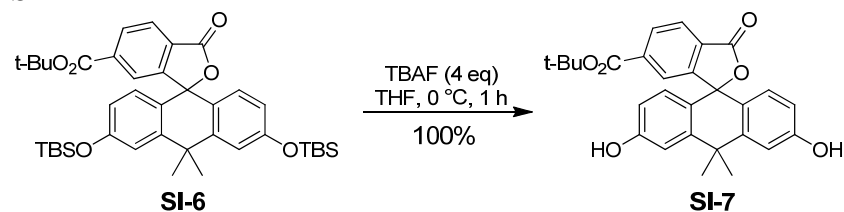
SI-7

Tetrabutylammonium fluoride trihydrate (2.52 g, 8 mmol, 4 equiv), dissolved in THF (15 mL), was added a solution of **SI-6** (1.38 g, 2 mmol) in THF (15 mL), cooled in ice-water bath. The resulting intense fuchsine-red solution was stirred at 0 °C for 1 h. Sat. aq. NH₄Cl (20 mL) was added followed by minimal amount of water necessary to dissolve the solids, the mixture was extracted with ethyl acetate (3×30 mL), the combined organic layers were washed with brine and dried over Na₂SO₄. The product was isolated by flash column

chromatography (Teledyne Isco RediSep Rf 24 g; gradient 0% to 30% ethyl acetate – CH₂Cl₂) and evaporated to give **SI-7** as viscous yellow oil, which was freeze-dried from dioxane to give light orange solid. Yield 0.92 g (100%).

¹H NMR (400 MHz, CDCl₃): δ 8.18 (dd, *J* = 8.0, 1.3 Hz, 1H), 8.05 (dd, *J* = 8.0, 0.7 Hz, 1H), 7.60 (t, *J* = 0.9 Hz, 1H), 7.04 (d, *J* = 2.5 Hz, 2H), 6.58 (dd, *J* = 8.6, 2.4 Hz, 2H), 6.49 (d, *J* = 8.7 Hz, 2H), 1.52 (s, 9H), 1.51 (s, 3H), 1.37 (s, 3H).

¹³C NMR (101 MHz, CDCl₃): δ 171.4, 164.6, 157.2, 155.2, 147.7, 138.3, 130.6, 129.7, 129.5, 125.4, 125.0, 122.4, 115.1, 113.3, 83.1, 38.3, 34.7, 32.6, 28.1.

ESI-MS, positive mode: *m/z* (rel. int., %) = 459.2 [M+H]⁺. ESI-MS, negative mode: *m/z* (rel. int., %) = 457.5 [M-H]⁻.

HR-MS (ESI, positive mode): 459.1792 [M+H]⁺ (found), 459.1802 (calculated for C₂₈H₂₇O₆, [M+H]⁺).

SI-8

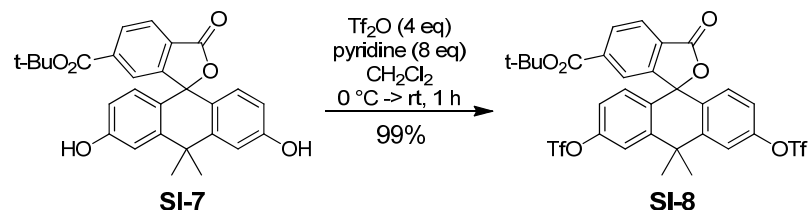

Trifluoromethanesulfonic anhydride (Tf₂O; 168 μL, 282 mg, 1 mmol, 4 equiv) was added dropwise to a solution of **SI-7** (115 mg, 0.25 mmol) and pyridine (161 μL, 158 mg, 2 mmol, 8 equiv) in dry CH₂Cl₂ (6 mL), cooled in ice-water bath. The flask was then removed from the cooling bath, and the mixture was stirred at rt for 1 h. Afterwards, the mixture was diluted with water (30 mL), extracted with CH₂Cl₂ (3×20 mL), the combined extracts were washed with water, brine and dried over Na₂SO₄. The product **SI-8** was isolated by flash column chromatography (Biotage SNAP Ultra 10 g; gradient 5% to 40% ethyl acetate – hexane) as white solid, yield 180 mg (99%).

¹H NMR (400 MHz, CDCl₃): δ 8.25 (dd, *J* = 8.0, 1.3 Hz, 1H), 8.11 (dd, *J* = 8.0, 0.8 Hz, 1H), 7.61 (dd, *J* = 1.3, 0.7 Hz, 1H), 7.56 (d, *J* = 2.5 Hz, 2H), 7.10 (dd, *J* = 8.8, 2.6 Hz, 2H), 6.88 (d, *J* = 8.8 Hz, 2H), 1.91 (s, 3H), 1.81 (s, 3H), 1.55 (s, 9H).

¹⁹F NMR (376 MHz, CDCl₃): δ -72.69.

¹³C NMR (101 MHz, CDCl₃): δ 168.8, 163.9, 153.9, 150.4, 147.2, 138.9, 131.4, 131.1, 130.3, 128.8, 125.9, 124.7, 120.6, 119.8, 118.9 (q, ¹*J*_{C-F} = 320.9 Hz), 84.3, 83.1, 39.0, 34.8, 33.2, 28.2.

ESI-MS, positive mode: *m/z* (rel. int., %) = 723.3 [M+H]⁺.

HR-MS (ESI, positive mode): 723.0767 [M+H]⁺ (found), 723.0788 (calculated for C₃₀H₂₅O₁₀S₂F₆, [M+H]⁺).

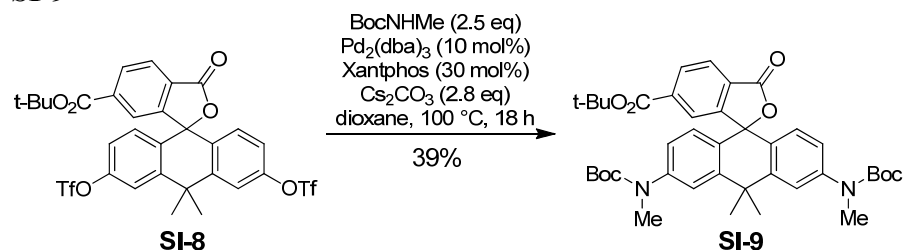
SI-9

A mixture of **SI-8** (115 mg, 0.16 mmol), *tert*-butyl *N*-methylcarbamate (52 mg, 0.4 mmol, 2.5 equiv), $\text{Pd}_2(\text{dba})_3$ (15 mg, 0.016 mmol, 10 mol%), Xantphos (28 mg, 0.048 mmol, 30 mol%) and Cs_2CO_3 (146 mg, 0.448 mmol, 2.8 equiv) in dry dioxane (2.5 mL) was degassed on a Schlenk line and stirred at 100 °C under argon (bath temperature) in a sealed flask for 18 h. Upon cooling, the resulting brown mixture was diluted with water (30 mL), extracted with ethyl acetate (3×30 mL), the combined organic layers were washed with brine and dried over Na_2SO_4 . The filtrate was evaporated on Celite and the product was isolated by flash column chromatography (Büchi Sepacore Silica HP 12 g; gradient 0% to 10% ethyl acetate – CH_2Cl_2) as viscous yellowish oil, yield 43 mg (39%).

$^1\text{H NMR}$ (400 MHz, CDCl_3): δ 8.18 (dd, $J = 8.0, 1.3$ Hz, 1H), 8.05 (dd, $J = 8.0, 0.7$ Hz, 1H), 7.60 (dd, $J = 1.3, 0.7$ Hz, 1H), 7.54 (d, $J = 2.2$ Hz, 2H), 7.02 (dd, $J = 8.6, 2.2$ Hz, 2H), 6.70 (d, $J = 8.5$ Hz, 2H), 3.28 (s, 6H), 1.87 (s, 3H), 1.77 (s, 3H), 1.54 (s, 9H), 1.47 (s, 18H).

$^{13}\text{C NMR}$ (101 MHz, CDCl_3): δ 169.7, 164.2, 155.1, 154.6, 145.4, 144.8, 138.2, 130.6, 129.3, 128.2, 127.5, 125.3, 124.9, 123.7, 123.7, 86.0, 82.7, 80.9, 38.4, 37.3, 34.9, 33.4, 28.5, 28.1.

ESI-MS, positive mode: m/z (rel. int., %) = 685.4 $[\text{M}+\text{H}]^+$, 707.4 $[\text{M}+\text{Na}]^+$.

HR-MS (ESI, positive mode): 685.3484 $[\text{M}+\text{H}]^+$ (found), 685.3483 (calculated for $\text{C}_{40}\text{H}_{49}\text{N}_2\text{O}_8$, $[\text{M}+\text{H}]^+$).

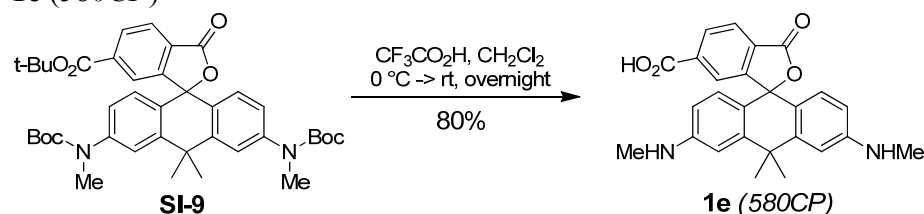
1e (580CP)

Trifluoroacetic acid (0.82 mL) was added dropwise to a solution of **SI-9** (43 mg, 0.063 mmol) in CH_2Cl_2 (4 mL), cooled in ice-water bath. The resulting bright red solution was stirred at rt overnight. The reaction mixture was then evaporated to dryness, the residue was re-evaporated twice with toluene to remove excess trifluoroacetic acid, and the product was isolated by flash column chromatography on reversed phase (5 g RP- C_{18} , gradient 33% to 50% THF – water). Fractions containing the product were evaporated and the residue was lyophilized from aqueous dioxane. Yield 26 mg (80%), blue solid (contains 1 mol dioxane per 1 mol dye).

$^1\text{H NMR}$ (400 MHz, CD_3OD): δ 8.35-8.28 (m, 2H), 7.86 (s, 1H), 7.11 (d, $J = 2.3$ Hz, 2H), 6.96 (d, $J = 9.1$ Hz, 2H), 6.61 (dd, $J = 9.1, 2.3$ Hz, 2H), 3.04 (s, 6H), 1.83 (s, 3H), 1.71 (s, 3H).

^{13}C NMR (101 MHz, CD_3OD): δ 159.1, 158.4, 138.3, 132.2, 131.5, 122.0, 113.9, 112.0, 42.6, 35.4, 32.0, 30.9, 30.0 (not all signals are resolved).

ESI-MS, positive mode: m/z (rel. int., %) = 429.2 $[\text{M}+\text{H}]^+$. ESI-MS, negative mode: m/z (rel. int., %) = 427.2 $[\text{M}-\text{H}]^-$.

HR-MS (ESI, positive mode): 429.1808 $[\text{M}+\text{H}]^+$ (found), 429.1809 (calculated for $\text{C}_{26}\text{H}_{25}\text{N}_2\text{O}_4$, $[\text{M}+\text{H}]^+$).

The tagged derivative **1e-Halo** was prepared as follows:

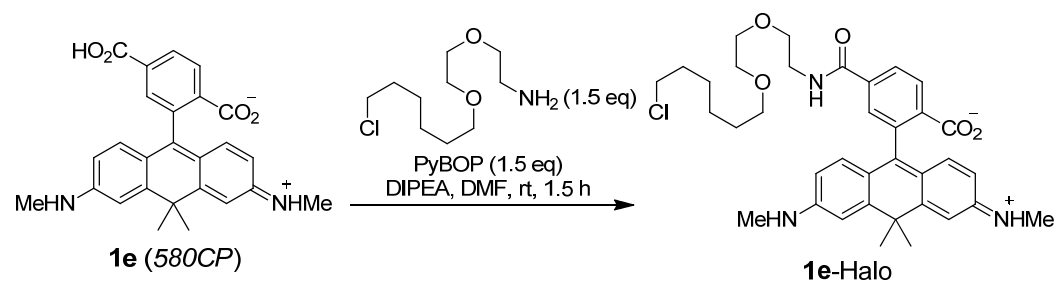

Dye **580CP** (**1e**; 3.1 mg, 7.31 μmol), HaloTag Amine (O2) (2-(2-((6-chlorohexyl)oxy)ethoxy)ethanamine; ^{13}C 2.5 mg, 10.97 μmol , 1.5 equiv) and *N,N*-diisopropylethylamine (DIPEA; 10 μL , 57.5 μmol) were dissolved in DMF (100 μL) to give a pale blue solution. PyBOP (25 μL of 23 mg/100 μL stock solution, 10.97 μmol , 1.5 equiv) was then added, and the mixture was stirred at rt for 1.5 h. Acetic acid (1 drop) was added and the solvents were evaporated *in vacuo* at rt. The product was isolated by preparative TLC (silica, 5% methanol – CH_2Cl_2) giving the material with 98% purity, which was lyophilized from 1,4-dioxane to give 1.6 mg (35%) of **1e-Halo** as blue fluffy solid.

ESI-MS, positive mode: m/z (rel. int., %) = 634.3 (100) $[\text{M}+\text{H}]^+$.

HR-MS (ESI, positive mode): 634.3042 $[\text{M}+\text{H}, ^{35}\text{Cl}]^+$ (found), 680.3042 (calculated for $\text{C}_{36}\text{H}_{45}\text{ClN}_3\text{O}_5$, $[\text{M}+\text{H}, ^{35}\text{Cl}]^+$).

^1H NMR (400 MHz, $\text{DMSO}-d_6$): δ 8.76 (t, $J = 5.6$ Hz, 1H), 8.09 (dd, $J = 8.0, 1.4$ Hz, 1H), 8.01 (dd, $J = 8.0, 0.7$ Hz, 1H), 7.47 (dd, $J = 1.4, 0.7$ Hz, 1H), 6.79 (d, $J = 2.2$ Hz, 2H), 6.37 (dd, $J = 8.7, 2.2$ Hz, 2H), 6.33 (d, $J = 8.6$ Hz, 2H), 5.87 (q, $J = 5.0$ Hz, 2H), 3.58 (t, $J = 6.7$ Hz, 2H), 3.49 – 3.44 (m, 4H), 3.43 – 3.38 (m, 2H), 3.36 – 3.26 (m, 2H), 3.01 (td, $J = 6.6, 3.9$ Hz, 2H), 2.70 (d, $J = 4.9$ Hz, 6H), 1.78 (s, 3H), 1.70 – 1.60 (m, 2H), 1.64 (s, 3H), 1.40 (dt, $J = 13.9, 6.7$ Hz, 2H), 1.35 – 1.28 (m, 2H), 1.28 – 1.20 (m, 2H).

^{13}C NMR (101 MHz, $\text{DMSO}-d_6$): δ 128.7, 128.9, 125.1, 122.6, 111.8, 108.5, 70.5, 69.8, 69.9, 69.0, 46.3, 45.7, 40.4, 39.9, 39.8, 35.5, 32.9, 32.5, 29.4, 29.2, 26.5, 25.3 (indirect detection from HSQC experiment; only H-coupled carbons are resolved).

HPLC (1.2 mL/min, gradient A:B = 30:70 \rightarrow 100:0 over 25 min, detection at 254 nm): $t = 11.83$ min.

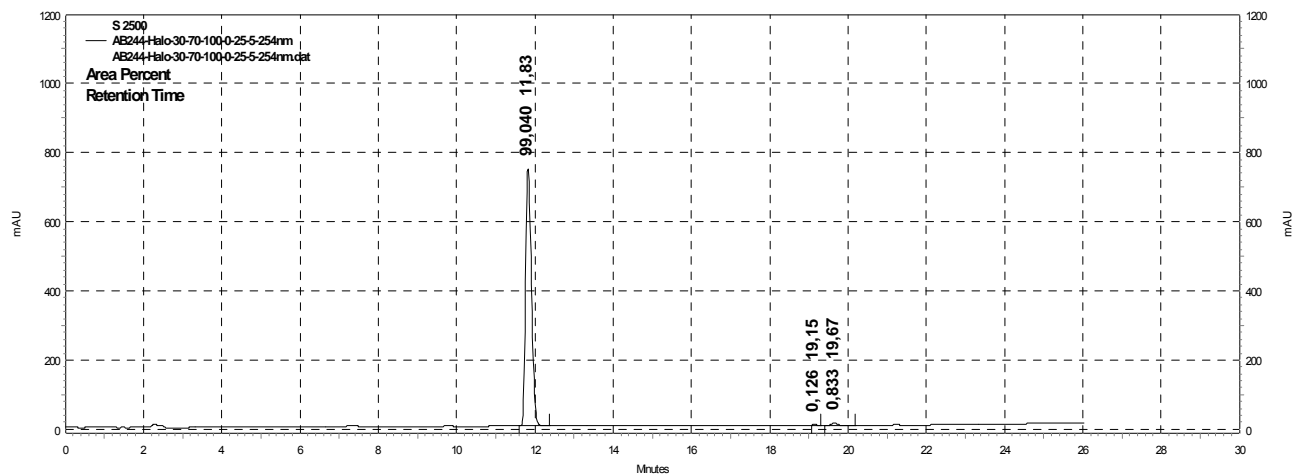

Fluorescent dye **610CP** (**1f**)

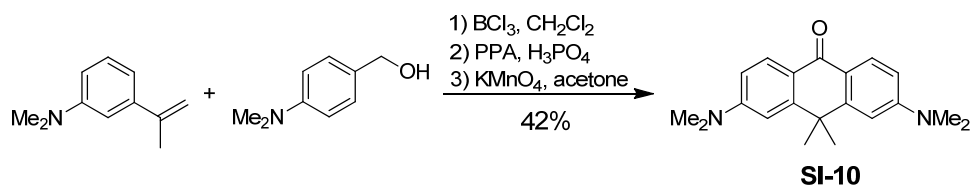

Method 1:

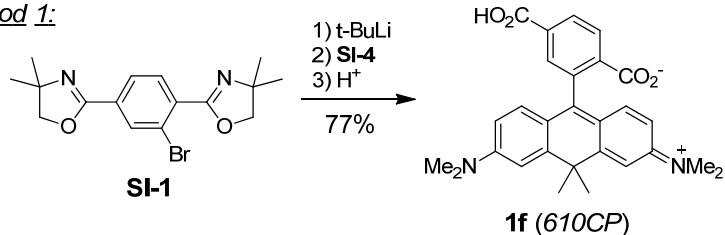

Method 2:

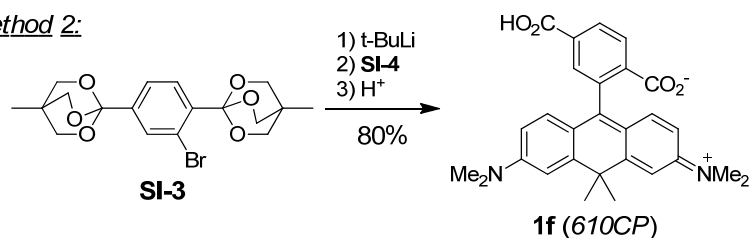

SI-10^[S10]

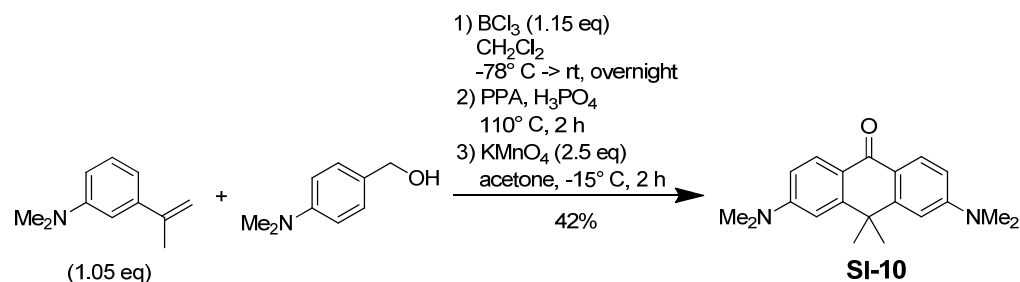

To a solution of 3-isopropenyl-*N,N*-dimethylaniline^[S11] (1.05 g, 6.52 mmol, 1.05 equiv) and 4-(dimethylamino)benzyl alcohol^[S12] (938 mg, 6.21 mmol) in CH₂Cl₂ (80 mL), cooled to -78 °C, BCl₃ (7.14 mL of 1 M in CH₂Cl₂, 7.14 mmol, 1.15 equiv) was added quickly dropwise. The reaction mixture was then allowed to warm up to rt (the suspension turned into a clear yellow-green solution) and stirred overnight under nitrogen atmosphere. The solvents were evaporated, polyphosphoric acid (PPA; 30 g) and phosphoric acid (85 wt.% in water; 8 mL) were added to the residue and the mixture was stirred at 110 °C (bath temperature) for 2 h. The viscous solution was poured onto crushed ice (~100 mL) and neutralized by gradual addition of solid KOH and ice until basic. The mixture was then extracted with CH₂Cl₂ (4×70 mL), the combined organic layers were dried over Na₂SO₄ and evaporated. The crude residue was redissolved in acetone (40 mL), cooled to ~ -15 °C (2-propanol/water 1:1 – dry ice bath), and powdered KMnO₄ (2.5 g, 15.8 mmol, ~2.5 equiv) was added in small portions over 1 h. The resulting mixture was stirred at -15 °C for 1.5 h, Celite was added followed by cold (-78 °C) CH₂Cl₂ (100 mL), and the suspension was filtered through a layer of Celite, washing the filter cake with CH₂Cl₂ (150 mL). The filtrate was evaporated, and the product was isolated by flash column chromatography (100 g silica, gradient 20% to 66% EtOAc – hexane), the

fractions containing the product (yellow fluorescent spot on TLC) were pooled, evaporated and the residue was recrystallized from ethanol (20 mL), giving 700 mg of **SI-10**. The second crop (105 mg) was obtained by concentration of the filtrate and second crystallization. Yellow crystals, overall yield 805 mg (42%).

^1H NMR (400 MHz, CDCl_3): δ 8.27 (d, $J = 8.6$ Hz, 2H), 6.80 – 6.72 (m, 4H), 3.10 (s, 12H), 1.72 (s, 6H).

^{13}C NMR (101 MHz, CDCl_3): δ 181.3, 153.1, 152.4, 129.3, 120.2, 111.0, 108.0, 40.4, 38.3, 33.9.

ESI-MS, positive mode: m/z (rel. int., %) = 309.2 (100) $[\text{M}+\text{H}]^+$.

1f (610CP) (from **SI-1**)

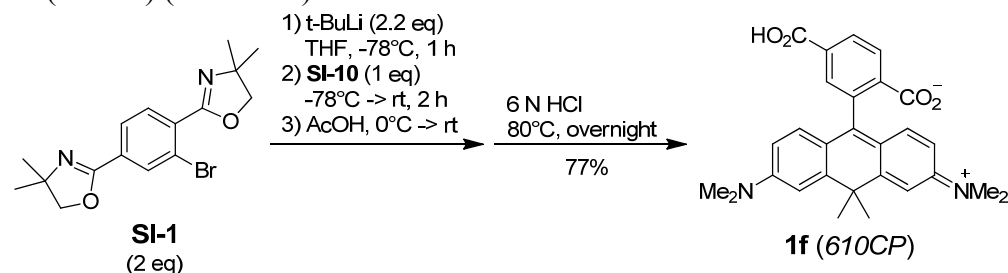

To a solution of bis-oxazoline **SI-1** (233 mg, 0.65 mmol, 2 equiv) in THF (5 mL), cooled to -78°C , *t*-BuLi (0.44 mL of 1.7 M in pentane, 0.75 mmol, ~ 2.2 equiv) was added, and the mixture was stirred at -78°C for 1 h, gradually turning light orange. A solution of ketone **SI-4** (101 mg, 0.33 mmol) in THF (5 mL) was added dropwise, and the mixture was allowed to warm up to rt and stirred for 2 h. The resulting greenish-brown solution was cooled in ice-water bath, and acetic acid (1.6 mL) was added. The dark blue reaction mixture, showing intense red fluorescence, was evaporated on a rotary evaporator (bath temperature 40°C) to a viscous residue, which was dissolved in 6 N HCl (20 mL), and the resulting dark orange solution was stirred at 80°C overnight. The yellow turbid mixture was cooled in ice-water bath, and pH was adjusted to 1-2 by careful addition of NaHCO_3 . The mixture was extracted with CH_2Cl_2 (5×50 mL), the poorly soluble dye was dissolved by addition of methanol to the combined organic layers, which were then dried over Na_2SO_4 , filtered and evaporated. The product was isolated by flash column chromatography (40 g silica, gradient 20% to 66% methanol – CH_2Cl_2), the fractions containing the product were evaporated, the residue was redissolved in 1,4-dioxane – water (1:1), microfiltered through a $0.45 \mu\text{m}$ PTFE membrane filter, evaporated to dryness and lyophilized. Yield 115 mg (77%), dark blue solid with red reflection.

^1H NMR (400 MHz, CD_3OD): δ 8.24 (dd, $J = 8.1, 1.5$ Hz, 1H), 8.12 (d, $J = 8.1$ Hz, 1H), 7.70 (d, $J = 1.6$ Hz, 1H), 7.08 (d, $J = 2.6$ Hz, 2H), 6.81 (d, $J = 9.1$ Hz, 2H), 6.68 (dd, $J = 9.1, 2.6$ Hz, 2H), 3.12 (s, 12H), 1.86 (s, 3H), 1.75 (s, 3H).

^{13}C NMR (101 MHz, CD_3OD): δ 171.1, 169.6, 155.2, 153.2, 133.8, 131.3, 128.9, 128.6, 121.0, 113.5, 111.2, 41.3, 40.8, 35.6, 33.1.

ESI-MS, positive mode: m/z (rel. int., %) = 457.3 (100) $[\text{M}+\text{H}]^+$. ESI-MS, negative mode: m/z (rel. int., %) = 455.4 (100) $[\text{M}-\text{H}]^+$.

HR-MS (ESI, positive mode): 457.2124 $[\text{M}+\text{H}]^+$ (found), 457.2122 (calculated for $\text{C}_{28}\text{H}_{29}\text{N}_2\text{O}_4$, $[\text{M}+\text{H}]^+$).

UV-Vis (PBS, pH 7.4): absorption, λ_{max} , nm (ϵ , $\text{M}^{-1}\text{cm}^{-1}$): 609 (100000); emission, λ_{max} , nm (Φ): 634 (0.59).

1f (610CP) (from SI-3)

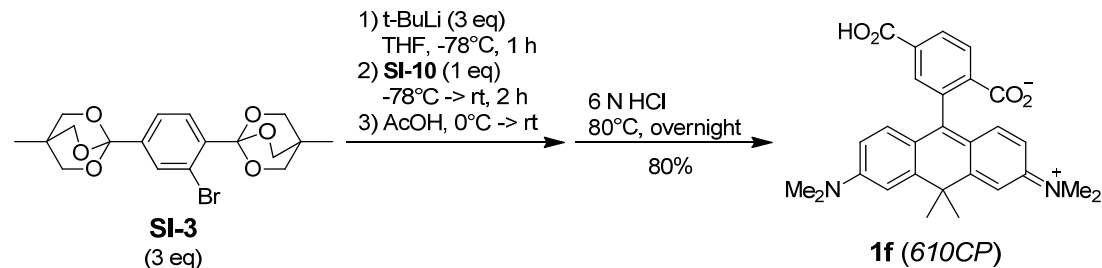

tert-Butyllithium (0.53 mL of 1.7 M in pentane, 0.90 mmol, 3 equiv) was added dropwise to a cold (-78 °C) solution of **SI-3** (372 mg, 0.90 mmol, 3 equiv) in THF (10 mL). The resulting brown-orange solution was stirred at -78 °C for 1 h, turning orange-yellow. A solution of ketone **SI-10** (93 mg, 0.30 mmol) in THF (3 mL) was added dropwise, and the mixture was allowed to warm up to rt and stirred for 2 h. The resulting solution was cooled in ice-water bath, and acetic acid (1.5 mL) was added. The blue reaction mixture was evaporated on a rotary evaporator (bath temperature 40 °C) to a viscous residue, which was dissolved in 6 N HCl (20 mL), and the resulting dark orange solution was stirred at 80°C overnight. The yellow turbid mixture was cooled in ice-water bath, and pH was adjusted to 1-2 by careful addition of NaHCO₃. The mixture was saturated by addition of anhydrous Na₂SO₄ and extracted with CH₂Cl₂ – *i*-PrOH (4×50 mL). The combined extracts were dried over Na₂SO₄, filtered and evaporated. The product was isolated by flash column chromatography (12 g silica, gradient 5% to 50% methanol – CH₂Cl₂), the fractions containing the product were evaporated, and the crude product was further purified by flash chromatography on reversed phase (11 g RP-C₁₈, gradient 80% to 20% H₂O – acetonitrile). The fractions containing the product were evaporated to blue solid, which was redissolved in 1,4-dioxane, microfiltered through a 0.2 μm PTFE membrane filter and lyophilized. Yield 110 mg (80%), blue fluffy solid (see above for the analytical data).

The tagged derivative **1f-Halo** was prepared as follows:

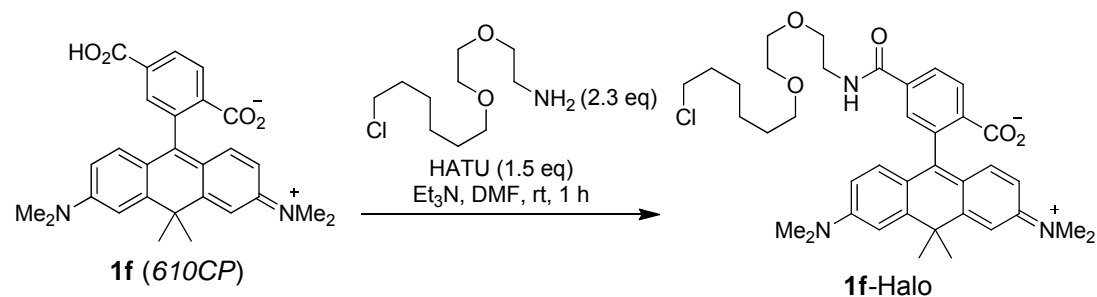

HATU (10 μL of 25 mg/100 μL stock solution, 6.57 μmol, 1.5 equiv) was added to a solution of **1f** (2 mg, 4.38 μmol), HaloTag Amine (O2) (2-(2-((6-chlorohexyl)oxy)ethoxy)ethanamine^[S13], 2.3 mg, 10.3 μmol, 2.3 equiv) and triethylamine (6 μL) in DMF (100 μL). After 1 h, the solvent was evaporated *in vacuo* at rt, and the product was isolated by preparative TLC (silica, 5% methanol – CH₂Cl₂) giving the material with ~90% purity, from which pure **1f-Halo** was isolated by preparative HPLC. Yield 1.1 mg (38%) of dark blue foam.

¹H NMR (400 MHz, CD₃OD): δ 8.34 (d, *J* = 8.2 Hz, 1H), 8.16 (dd, *J* = 8.2, 1.8 Hz, 1H), 7.75 (d, *J* = 1.7 Hz, 1H), 7.23 (d, *J* = 2.5 Hz, 2H), 7.01 (d, *J* = 9.4 Hz, 2H), 6.80 (dd, *J* = 9.4, 2.5 Hz, 2H), 3.68 – 3.54 (m, 8H), 3.52 (t, *J* = 6.6 Hz, 2H), 3.43 (t, *J* = 6.5 Hz, 2H), 3.32 (s, 12H), 1.88 (s, 3H), 1.77 (s, 3H), 1.71 (dq, *J* = 8.0, 6.6 Hz, 2H), 1.51 (tt, *J* = 7.7, 6.3 Hz, 2H), 1.45 – 1.28 (m, 4H).

^{13}C NMR (101 MHz, CD_3OD): δ 136.0, 130.7, 128.5, 127.9, 112.5, 110.4, 70.7, 69.8, 68.9, 44.3, 39.7, 39.5, 34.2, 32.2, 31.3, 29.0, 26.3, 25.1 (indirect detection from HSQC experiment; only H-coupled carbons are resolved).

ESI-MS, positive mode: m/z (rel. int., %) = 662.4 (100) $[\text{M}+\text{H}]^+$.

HR-MS (ESI, positive mode): 662.3358 $[\text{M}+\text{H}, ^{35}\text{Cl}]^+$ (found), 662.3355 (calculated for $\text{C}_{38}\text{H}_{49}\text{ClN}_3\text{O}_5$, $[\text{M}+\text{H}, ^{35}\text{Cl}]^+$).

HPLC (1.2 mL/min, gradient A:B = 30:70 \rightarrow 100:0 over 25 min, detection at 254 nm): $t = 13.77$ min.

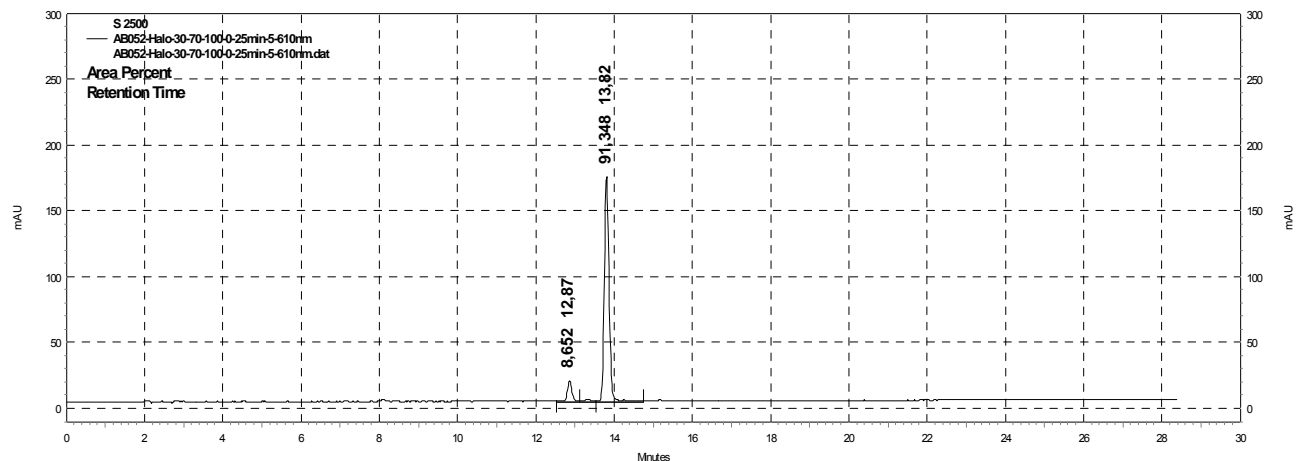

Fluorescent dye **620CP** (**1g**)

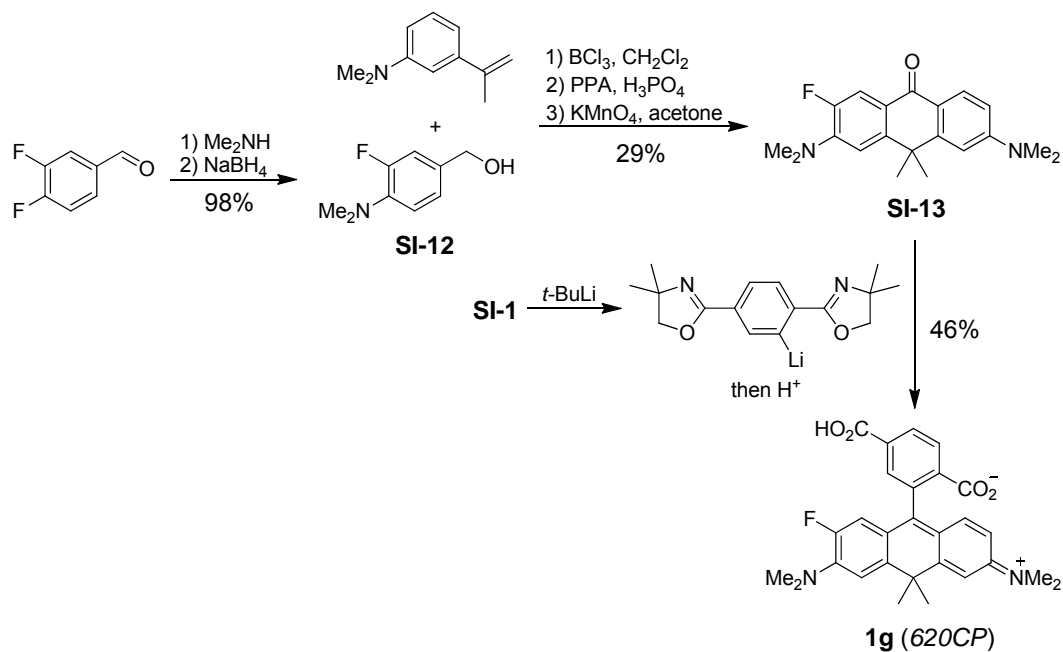

SI-11

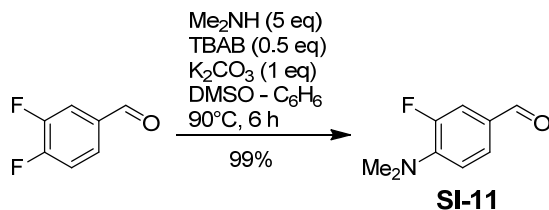

A mixture of 3,4-difluorobenzaldehyde (2 mL, 2.58 g, 18.16 mmol), tetrabutylammonium bromide (TBAB; 2.92 g, 9.08 mmol, 0.5 equiv), potassium carbonate (2.51 g, 18.16 mmol, 1 equiv) and dimethylamine (27 mL of 15 wt.% solution in benzene, ~90 mmol, ~5 equiv) in dimethyl sulfoxide (10 mL) was refluxed at 90°C (bath temperature) for 6 h. The resulting yellow suspension was poured into 5% aq. NaHCO_3 (400 mL), extracted with CH_2Cl_2 (3×100 mL), the combined organic layers were washed with water, brine and dried over Na_2SO_4 . The product was isolated by flash column chromatography (80 g silica, gradient 20% to 25% EtOAc – hexane) and dried *in vacuo* to give 3.02 g (99%) of **SI-11** as a light yellow oil.

^1H NMR (400 MHz, CDCl_3): δ 9.74 (d, $J = 2.1$ Hz, 1H), 7.50 (dd, $J = 8.4, 2.0$ Hz, 1H), 7.46 (dd, $J = 14.1, 2.0$ Hz, 1H), 6.80 (t, $J = 8.5$ Hz, 1H), 3.04 (d, $J = 2.0$ Hz, 6H).

^{19}F NMR (376 MHz, CDCl_3): δ -122.89.

^{13}C NMR (101 MHz, CDCl_3): δ 189.7 (d, $J = 2.2$ Hz), 153.0 (d, $J = 245.7$ Hz), 145.3 (d, $J = 8.0$ Hz), 128.2 (d, $J = 2.2$ Hz), 127.8 (d, $J = 5.9$ Hz), 116.3 (d, $J = 21.9$ Hz), 116.0 (d, $J = 4.2$ Hz), 42.2 (d, $J = 6.1$ Hz).

ESI-MS, positive mode: m/z (rel. int., %) = 168.1 (100) $[\text{M}+\text{H}]^+$.

HR-MS (ESI, positive mode): 168.0819 $[\text{M}+\text{H}]^+$ (found), 168.0819 (calculated for $\text{C}_9\text{H}_{11}\text{FNO}$, $[\text{M}+\text{H}]^+$).

SI-12

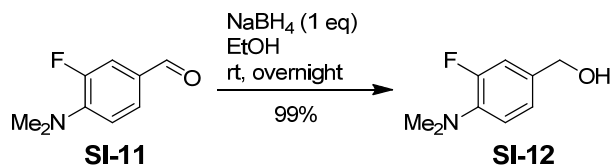

Solid NaBH₄ (690 mg, 18.16 mmol, 1 equiv) was added to a solution of aldehyde **SI-11** (3.02 g, 18.06 mmol) in ethanol (40 mL), and the reaction mixture was stirred overnight under nitrogen. The solvent was evaporated, the residue was treated with minimal volume of water to dissolve solids and extracted with CH₂Cl₂ (3×50 mL), the combined organic layers were dried over Na₂SO₄. The product was isolated by flash column chromatography (80 g silica, gradient 20% to 100% EtOAc – hexane) and dried *in vacuo* to give 3.03 g (99%) of **SI-12** as a colorless oil.

¹H NMR (400 MHz, CDCl₃): δ 7.02 – 6.97 (m, 2H), 6.89 – 6.83 (m, 1H), 4.54 (s, 2H), 2.81 (d, *J* = 0.9 Hz, 6H), 2.58 (br.s, 1H).

¹⁹F NMR (376 MHz, CDCl₃): δ -122.12.

¹³C NMR (101 MHz, CDCl₃): δ 155.1 (d, *J* = 246.3 Hz), 139.9 (d, *J* = 9.2 Hz), 134.8 (d, *J* = 6.5 Hz), 122.9 (d, *J* = 3.1 Hz), 118.4 (d, *J* = 3.5 Hz), 115.1 (d, *J* = 21.3 Hz), 64.4 (d, *J* = 1.4 Hz), 43.0 (d, *J* = 4.1 Hz).

ESI-MS, positive mode: *m/z* (rel. int., %) = 170.1 (100) [M+H]⁺.

HR-MS (ESI, positive mode): 170.0981 [M+H]⁺ (found), 170.0976 (calculated for C₉H₁₃FNO, [M+H]⁺).

SI-13

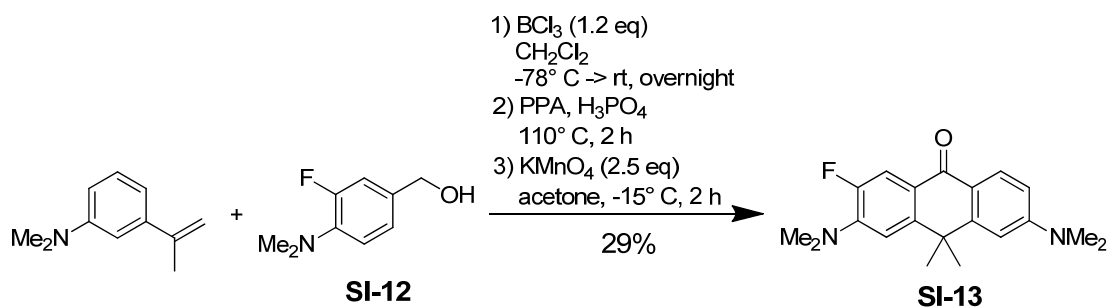

To a solution of 3-isopropenyl-*N,N*-dimethylaniline^[S11] (400 mg, 2.48 mmol, 1 equiv) and benzyl alcohol **SI-12** (423 mg, 2.50 mmol, 1 equiv) in CH₂Cl₂ (20 mL), cooled to -78 °C, BCl₃ (3 mL of 1 M in CH₂Cl₂, 3 mmol, 1.2 equiv) was added quickly dropwise. The reaction mixture was allowed to warm up to rt, and the resulting thin yellowish suspension was stirred overnight under nitrogen atmosphere. The solvents were evaporated, polyphosphoric acid (PPA; 12 g) and phosphoric acid (85 wt.% in water; 3 mL) were added to the residue and the mixture was stirred at 110 °C (bath temperature) for 2 h. The viscous solution was poured onto crushed ice (~100 mL) and neutralized by gradual addition of solid KOH and ice until basic. The mixture was then extracted with CH₂Cl₂ (4×30 mL), the combined organic layers were dried over Na₂SO₄ and evaporated. The crude residue was redissolved in acetone (15 mL), cooled to -15 °C (2-propanol/water 1:1 – dry ice bath), and powdered KMnO₄ (960 mg, 6.08 mmol, ~2.5 equiv) was added in

small portions over 30 min. The resulting mixture was stirred at -15 °C for 1.5 h, Celite was added followed by cold (-78 °C) CH₂Cl₂ (80 mL), and the suspension was filtered through a layer of Celite, washing the filter cake with CH₂Cl₂ (120 mL). The filtrate was evaporated, and the product was isolated by flash column chromatography (100 g silica, gradient 25% to 50% EtOAc – hexane), the fractions containing the product (yellow fluorescent spot on TLC) were pooled, evaporated and the residue was recrystallized from CH₂Cl₂ – hexane, yielding 280 mg of **SI-13** in ~90% purity. The product was further purified by flash chromatography on reversed phase (40 g RP-C₁₈, gradient 50% to 33% H₂O – acetonitrile), the fractions containing the product were evaporated to dryness, redissolved in CH₂Cl₂, microfiltered through a 0.45 μm PTFE membrane filter, the filtrate was evaporated and the residue recrystallized from CH₂Cl₂ – hexane. Fluffy light-yellow crystals, yield 240 mg (29%).

¹H NMR (400 MHz, acetone-*d*₆): δ 8.10 (d, *J* = 8.9 Hz, 1H), 7.77 (d, *J* = 14.8 Hz, 1H), 7.15 (d, *J* = 8.6 Hz, 1H), 6.93 (d, *J* = 2.5 Hz, 1H), 6.82 (dd, *J* = 8.9, 2.5 Hz, 1H), 3.13 (s, 6H), 3.04 (d, *J* = 1.4 Hz, 6H), 1.72 (s, 6H).

¹⁹F NMR (376 MHz, acetone-*d*₆): δ -126.66.

¹³C NMR (101 MHz, acetone-*d*₆): δ 180.1 (d, *J* = 1.6 Hz), 154.5, 153.6 (d, *J* = 243.7 Hz), 153.3, 148.7 (d, *J* = 2.6 Hz), 145.0 (d, *J* = 8.8 Hz), 129.5, 124.0 (d, *J* = 6.1 Hz), 119.9 (d, *J* = 1.1 Hz), 115.7 (d, *J* = 3.8 Hz), 113.7 (d, *J* = 21.9 Hz), 111.8, 108.9, 42.5 (d, *J* = 5.4 Hz), 40.2, 38.7, 33.7.

ESI-MS, positive mode: *m/z* (rel. int., %) = 327.2 (100) [M+H]⁺.

HR-MS (ESI, positive mode): 327.1869 [M+H]⁺ (found), 327.1867 (calculated for C₂₀H₂₄FN₂O, [M+H]⁺).

1g (620CP)

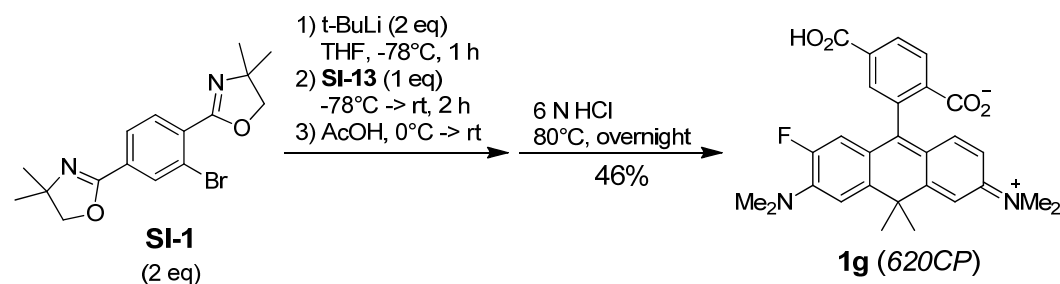

To a solution of bis-oxazoline **SI-1** (176 mg, 0.50 mmol, 2 equiv) in THF (3 mL), cooled to -78°C, *t*-BuLi (0.3 mL of 1.7 M in pentane, 0.51 mmol, ~2 equiv) was added, and the mixture was stirred at to -78°C for 1 h. A solution of ketone **SI-13** (82 mg, 0.25 mmol) in THF (3 mL) was then added dropwise, and the mixture was allowed to warm up to rt and stirred for 2 h. The resulting solution was cooled in ice-water bath, and acetic acid (1.2 mL) was added. The greenish-blue reaction mixture was evaporated on a rotary evaporator (bath temperature 40°C) to a viscous residue, which was dissolved in 6 N HCl (15 mL), and the resulting orange solution was stirred at 80°C overnight. The brown mixture was cooled in ice-water bath, and the pH was adjusted to 1-2 by careful addition of NaHCO₃. The mixture was extracted with CH₂Cl₂ (4×50 mL), the poorly soluble dye was dissolved by addition of methanol to the combined organic layers, which were then dried over Na₂SO₄, filtered and evaporated. The product was isolated by flash column

chromatography (40 g silica, gradient 5% to 15% methanol – CH₂Cl₂), the fractions containing the product were pooled and evaporated, and the residue was repurified by flash chromatography on reversed phase (20 g RP-C₁₈, 50% H₂O – acetonitrile). The solvents were evaporated, the product was redissolved in 1,4-dioxane – water (1:1), microfiltered through a 0.45 μm PTFE membrane filter and lyophilized. Yield 55 mg (46%), fluffy turquoise solid.

¹H NMR (301 MHz, DMSO-*d*₆): δ 8.16 (dd, *J* = 8.0, 1.2 Hz, 1H), 8.06 (d, *J* = 7.9 Hz, 1H), 7.43 (s, 1H), 7.16 (d, *J* = 9.2 Hz, 1H), 6.92 (d, *J* = 2.6 Hz, 1H), 6.59 (dd, *J* = 8.9, 2.5 Hz, 1H), 6.46 (d, *J* = 8.8 Hz, 1H), 6.31 (d, *J* = 14.3 Hz, 1H), 2.94 (s, 6H), 2.86 (s, 6H), 1.83 (s, 3H), 1.73 (s, 3H).

¹⁹F NMR (283 MHz, DMSO-*d*₆): δ -124.35.

¹³C NMR (126 MHz, DMSO-*d*₆): δ 208.5, 168.9, 166.1, 154.9, 152.3 (d, *J* = 244.5 Hz), 150.6, 145.6, 141.8 (d, *J* = 2.7 Hz), 141.1 (d, *J* = 8.5 Hz), 130.3, 128.2, 127.9, 125.1, 123.6, 122.3 (d, *J* = 6.4 Hz), 117.0, 115.8 (d, *J* = 3.7 Hz), 113.4 (d, *J* = 21.8 Hz), 112.0, 109.0, 86.2, 68.0, 42.03 (d, *J* = 4.5 Hz), 37.7, 34.3, 33.6.

ESI-MS, positive mode: *m/z* (rel. int., %) = 475.2 (100) [M+H]⁺. ESI-MS, negative mode: *m/z* (rel. int., %) = 473.4 (100) [M-H]⁻.

HR-MS (ESI, positive mode): 475.2025 [M+H]⁺ (found), 475.2028 (calculated for C₂₈H₂₈FN₂O₄, [M+H]⁺).

UV-Vis (PBS, pH 7.4): absorption, λ_{max}, nm (ε, M⁻¹cm⁻¹): 617 (73000); emission, λ_{max}, nm (Φ): 647 (0.17).

The tagged derivative **1g-Halo** was prepared as follows:

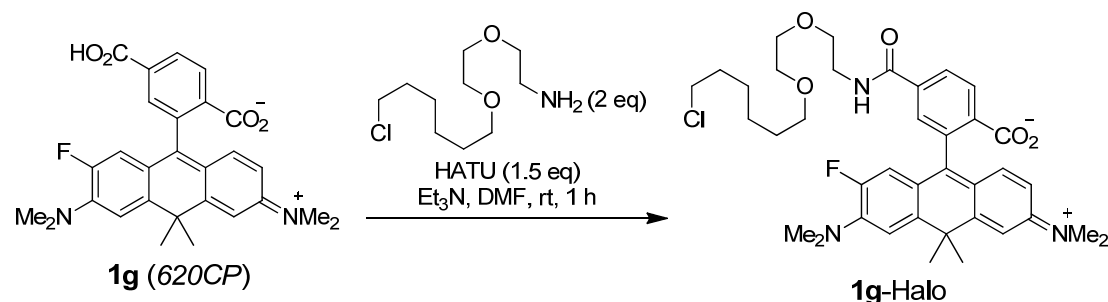

HATU (18 μL of 20 mg/100 μL stock solution, 9.48 μmol, 1.5 equiv) was added to a solution of **1g** (3 mg, 6.32 μmol), HaloTag Amine (O2) (2-(2-((6-chlorohexyl)oxy)ethoxy)ethanamine;^[S13] 2.8 mg, 12.64 μmol, 2 equiv) and triethylamine (9 μL) in DMF (100 μL). The reaction mixture was stirred at rt overnight. The solvent was evaporated *in vacuo* at rt, and the product was isolated by preparative TLC (silica, methanol – CH₂Cl₂ 2:100) giving the material with ~90% purity, from which pure **1g-Halo** was isolated by preparative HPLC. Yield 1 mg (23%) of light-blue solid.

ESI-MS, positive mode: *m/z* (rel. int., %) = 680.4 (100) [M+H]⁺.

HR-MS (ESI, positive mode): 680.3262 [M+H, ³⁵Cl]⁺ (found), 680.3261 (calculated for C₃₈H₄₈ClFN₃O₅, [M+H, ³⁵Cl]⁺).

¹H NMR (400 MHz, CDCl₃): δ 8.04 (dd, *J* = 8.0, 0.7 Hz, 1H), 7.94 (dd, *J* = 8.0, 1.5 Hz, 1H), 7.44 (dd, *J* = 1.4, 0.7 Hz, 1H), 7.04 (br.d, *J* = 8.9 Hz, 1H), 6.86 (br.s, 1H), 6.75 (br.t, *J* = 4.5 Hz, 1H), 6.56 (d, *J* = 8.8 Hz, 1H), 6.52 (dd, *J* = 8.9, 2.4 Hz, 1H), 6.29 (d, *J* = 13.9 Hz, 1H), 3.63 – 3.58 (m, 6H), 3.55 – 3.49 (m, 4H), 3.38

(t, $J = 6.7$ Hz, 2H), 2.99 (s, 6H), 2.90 (s, 6H), 1.86 (s, 3H), 1.78 – 1.70 (m, 2H), 1.75 (s, 3H), 1.52 (dt, $J = 14.3, 7.0$ Hz, 2H), 1.46 – 1.37 (m, 2H), 1.36 – 1.27 (m, 2H).

^{19}F NMR (283 MHz, CDCl_3): δ -124.38.

^{13}C NMR (101 MHz, CDCl_3): δ 128.9, 127.8, 125.2, 122.8, 115.6, 114.6, 111.9, 109.1, 71.2, 70.2, 69.9, 69.5, 45.0, 42.5, 40.4, 39.9, 35.3, 33.2, 32.4, 30.3, 29.3, 26.6, 25.3 (indirect detection from HSQC experiment; only H-coupled carbons are resolved).

HPLC (1.2 mL/min, gradient A:B = 30:70 \rightarrow 100:0 over 25 min, detection at 254 nm): $t = 14.57$ min.

Gradient : A% = 30 B% = 70 ----> A% = 100 B% = 0 T = 20 Min.

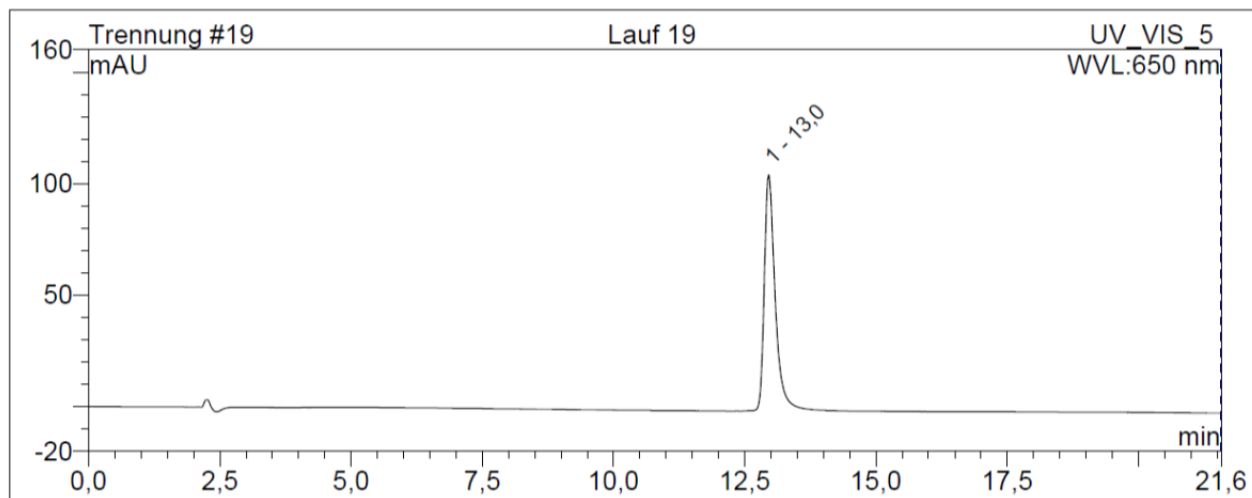

Fluorescent dye 630CP (1h)

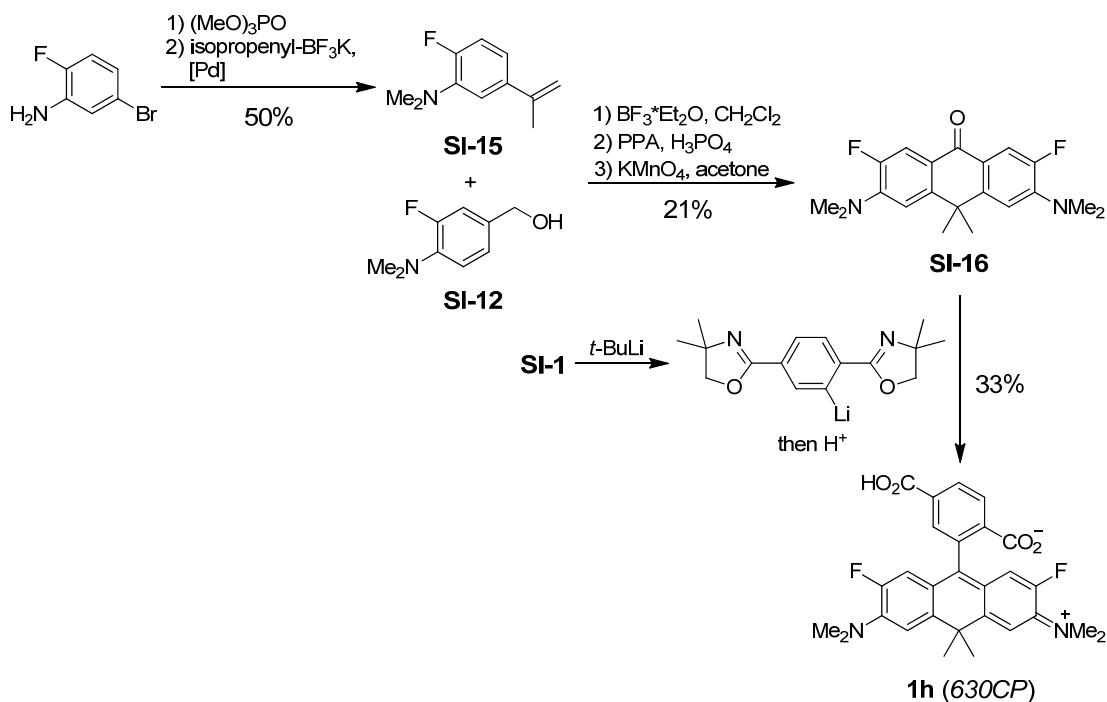

SI-14

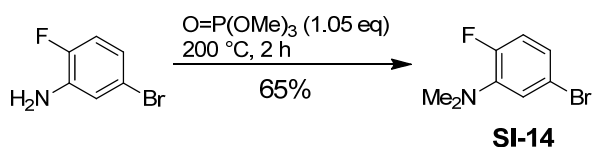

A mixture of 5-bromo-2-fluoroaniline (982 mg, 5.17 mmol) and trimethyl phosphate (760 mg, 5.43 mmol, 1.05 equiv) was stirred at $200\text{ }^\circ\text{C}$ (bath temperature) under argon for 2 h. The mixture was then allowed to cool, diluted with 1 N NaOH solution (15 mL) and stirred at rt overnight (under nitrogen). The resulting mixture was extracted with CH_2Cl_2 ($3 \times 20\text{ mL}$), the combined organic layers were washed with brine and dried over Na_2SO_4 . The product was isolated by flash column chromatography (30 g silica, gradient 20% to 100% CH_2Cl_2 – hexane). Colorless oil, yield 731 mg (65%).

^1H NMR (400 MHz, CDCl_3): δ 6.99 (dd, $J = 8.0, 2.3\text{ Hz}$, 1H), 6.94 (ddd, $J = 8.5, 4.0, 2.4\text{ Hz}$, 1H), 6.87 (dd, $J = 12.6, 8.5\text{ Hz}$, 1H), 2.85 (d, $J = 1.0\text{ Hz}$, 6H).

^{19}F NMR (376 MHz, CDCl_3): δ -124.63.

^{13}C NMR (101 MHz, CDCl_3): δ 154.1 (d, $J = 245.4\text{ Hz}$), 123.5 (d, $J = 7.2\text{ Hz}$), 121.3 (d, $J = 3.5\text{ Hz}$), 117.6 (d, $J = 22.6\text{ Hz}$), 116.9 (d, $J = 3.2\text{ Hz}$), 42.7 (d, $J = 4.5\text{ Hz}$).

ESI-MS, positive mode: m/z (rel. int., %) = 218.0 (100) $[\text{M}+\text{H}, ^{79}\text{Br}]^+$.

HR-MS (ESI, positive mode): 217.9978 $[\text{M}+\text{H}, ^{79}\text{Br}]^+$ (found), 217.9975 (calculated for $\text{C}_8\text{H}_{10}\text{BrFN}$, $[\text{M}+\text{H}, ^{79}\text{Br}]^+$).

SI-15

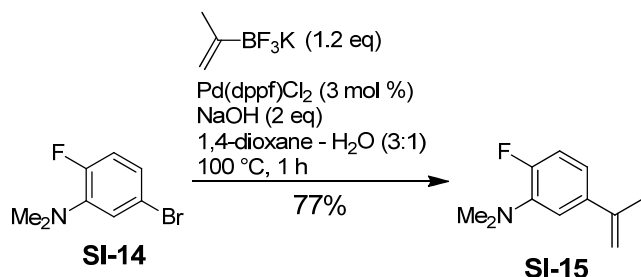

A mixture of aryl bromide **SI-14** (318 mg, 1.46 mmol), potassium isopropenyltrifluoroborate (259 mg, 1.70 mmol, 1.2 equiv) and Pd(dppf)Cl₂ (32 mg, 43.8 μmol, 3 mol %) in 1,4-dioxane (4.5 mL) in a 25 mL round-bottom flask was deoxygenated on a Schlenk line and filled with nitrogen. Aqueous NaOH (1.5 mL of 2 N solution) was then injected, and the orange solution quickly turned brown. The mixture was then heated up to 100 °C (bath temperature) and stirred for 1 h, cooled down to rt, diluted with 5% aqueous NaOH (20 mL) and extracted with CH₂Cl₂ (3×20 mL). The combined organic layers were washed with brine and dried over Na₂SO₄. The product was isolated by flash column chromatography (30 g silica, gradient 5% to 20% EtOAc – hexane). Colorless oil, yield 202 mg (77%).

¹H NMR (400 MHz, CDCl₃): δ 7.08 – 6.91 (m, 3H), 5.28 (s, 1H), 5.05 (p, *J* = 1.5 Hz, 1H), 2.87 (s, 6H), 2.13 (dd, *J* = 1.6, 0.8 Hz, 3H).

¹⁹F NMR (376 MHz, CDCl₃): δ -124.26.

¹³C NMR (101 MHz, CDCl₃): δ 154.9 (d, *J* = 246.0 Hz), 143.1, 137.9 (d, *J* = 3.4 Hz), 118.7 (d, *J* = 6.8 Hz), 115.9 (d, *J* = 3.7 Hz), 115.8 (d, *J* = 21.3 Hz), 112.2 (d, *J* = 1.5 Hz), 43.0 (d, *J* = 3.9 Hz), 22.2.

ESI-MS, positive mode: *m/z* (rel. int., %) = 180.1 (100) [M+H]⁺.

HR-MS (ESI, positive mode): 180.1189 [M+H]⁺ (found), 180.1183 (calculated for C₁₁H₁₅FN, [M+H]⁺).

SI-16

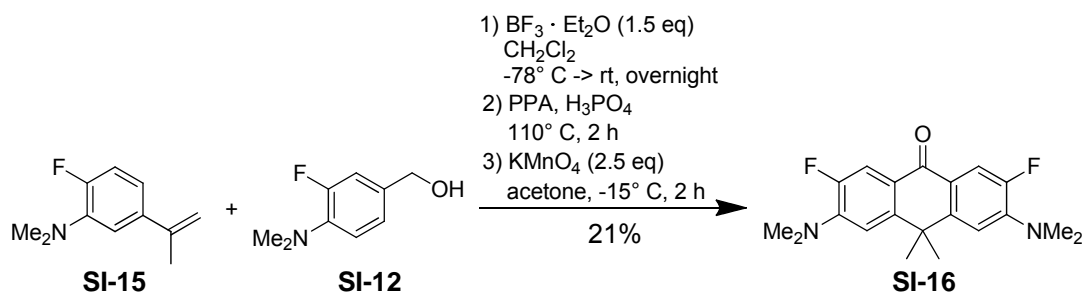

To a solution of alkene **SI-15** (790 mg, 4.41 mmol, 1 equiv) and benzyl alcohol **SI-12** (745 mg, 4.41 mmol, 1 equiv) in CH₂Cl₂ (40 mL), cooled to -78 °C, BF₃ · Et₂O (0.82 mL, 6.62 mmol, 1.5 equiv) was added quickly dropwise. The resulting thin suspension was allowed to warm up to rt, and the clear solution that formed was stirred overnight under nitrogen atmosphere. The solvents were evaporated, polyphosphoric acid (PPA; 20 g) and phosphoric acid (85 wt.% in water; 6 mL) were added to the residue and the mixture was stirred at

110 °C (bath temperature) for 2 h. The viscous solution was poured onto crushed ice (~100 mL) and neutralized by gradual addition of solid KOH and ice until basic. The mixture was then extracted with CH₂Cl₂ (4×30 mL), the combined organic layers were dried over Na₂SO₄ and evaporated. The crude residue was redissolved in acetone (27 mL), cooled to -15 °C (2-propanol/water 1:1 – dry ice bath), and powdered KMnO₄ (1.7 g, 10.76 mmol, ~2.5 equiv) was added in small portions over 30 min. The resulting mixture was stirred at -15 °C for 2 h, Celite was added followed by cold (-78 °C) CH₂Cl₂ (100 mL), and the suspension was filtered through a layer of Celite, washing the filter cake with CH₂Cl₂ (200 mL). The filtrate was evaporated, and the product was isolated by flash column chromatography (100 g silica, gradient 10% to 20% EtOAc – hexane), the fractions containing the product (yellow fluorescent spot on TLC) were pooled, evaporated and the resulting impure material was further purified by flash chromatography on reversed phase (30 g RP-C₁₈, gradient 30% to 10% H₂O – acetonitrile). The fractions containing the product were evaporated to dryness, redissolved in CH₂Cl₂, microfiltered through a 0.45 μm PTFE membrane filter, the filtrate was evaporated and the residue recrystallized from CH₂Cl₂ – hexane. Bright yellow crystals, yield 313 mg (21%).

¹H NMR (400 MHz, CDCl₃): δ 7.89 (d, *J* = 14.6 Hz, 2H), 6.89 (d, *J* = 8.3 Hz, 2H), 3.05 (d, *J* = 1.5 Hz, 12H), 1.68 (s, 6H).

¹⁹F NMR (376 MHz, CDCl₃): δ -125.02.

¹³C NMR (101 MHz, CDCl₃): δ 180.2 (t, *J* = 1.9 Hz), 152.8 (d, *J* = 245.6 Hz), 147.8 (d, *J* = 2.5 Hz), 144.5 (d, *J* = 9.0 Hz), 122.7 (d, *J* = 6.4 Hz), 114.06 (d, *J* = 22.1 Hz), 114.03 (d, *J* = 3.8 Hz), 42.4 (d, *J* = 5.7 Hz), 37.8, 33.7.

ESI-MS, positive mode: *m/z* (rel. int., %) = 345.2 (100) [M+H]⁺.

HR-MS (ESI, positive mode): 345.1778 [M+H]⁺ (found), 345.1773 (calculated for C₂₀H₂₃F₂N₂O, [M+H]⁺).

1h (F2-CP)

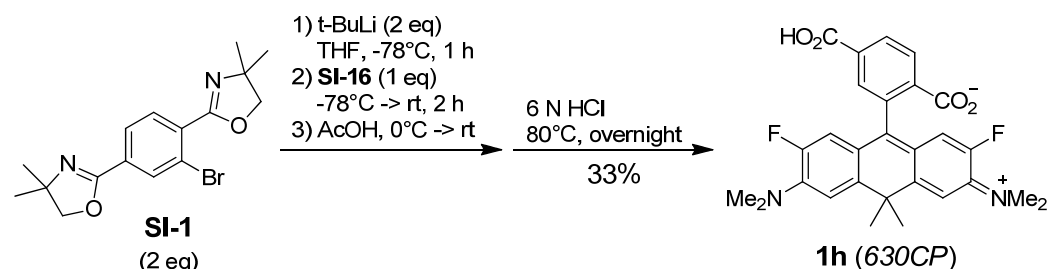

To a solution of bis-oxazoline **SI-1** (176 mg, 0.50 mmol, 2 equiv) in THF (3 mL), cooled to -78°C, *t*-BuLi (0.3 mL of 1.7 M in pentane, 0.51 mmol, ~2 equiv) was added, and the mixture was stirred at to -78°C for 1 h. A solution of ketone **SI-16** (86 mg, 0.25 mmol) in THF (3 mL) was then added dropwise, and the mixture was allowed to warm up to rt and stirred for 2 h. The resulting solution was cooled in ice-water bath, and acetic acid (1.2 mL) was added. The greenish-blue reaction mixture was evaporated on a rotary evaporator (bath temperature 40°C) to a viscous residue, which was dissolved in 6 N HCl (15 mL), and the resulting orange solution was stirred at 80°C overnight. The brown mixture was cooled in ice-water bath, and the pH was adjusted to 1-2 by careful addition of NaHCO₃. The mixture was extracted with CH₂Cl₂

(4×50 mL), the poorly soluble dye was dissolved by addition of methanol to the combined organic layers, which were then dried over Na₂SO₄, filtered and evaporated. The product was isolated by flash column chromatography (40 g silica, gradient 5% to 20% methanol – CH₂Cl₂), the fractions containing the product were pooled and evaporated, and the residue was repurified by flash chromatography on reversed phase (20 g RP-C₁₈, gradient 50% to 20% H₂O – acetonitrile). Acetonitrile was evaporated, 1,4-dioxane was added to the resulting suspension to dilute the solids, the solution was microfiltered through a 0.45 μm PTFE membrane filter and lyophilized. Yield 41 mg (33%), fluffy turquoise solid.

¹H NMR (400 MHz, acetone-*d*₆): δ 8.28 (dd, *J* = 8.0, 1.3 Hz, 1H), 8.08 (d, *J* = 7.9 Hz, 1H), 7.64 (t, *J* = 1.0 Hz, 1H), 7.21 (d, *J* = 9.0 Hz, 2H), 6.38 (d, *J* = 14.3 Hz, 2H), 2.89 (d, *J* = 1.0 Hz, 12H), 1.88 (s, 3H), 1.77 (s, 3H).

¹⁹F NMR (376 MHz, acetone-*d*₆): δ -125.20.

¹³C NMR (126 MHz, acetone-*d*₆): δ 209.7, 169.3, 166.6, 155.6, 153.8 (d, *J* = 244.3 Hz), 142.38 (d, *J* = 2.9 Hz), 142.36 (d, *J* = 8.6 Hz), 138.7, 131.5, 129.8, 126.0, 125.1, 123.2 (d, *J* = 6.5 Hz), 116.6 (d, *J* = 4.0 Hz), 114.5 (d, *J* = 22.4 Hz), 86.0, 69.2, 67.5, 42.6 (d, *J* = 4.7 Hz), 38.7, 34.9, 34.2.

ESI-MS, positive mode: *m/z* (rel. int., %) = 493.3 (100) [M+H]⁺. ESI-MS, negative mode: *m/z* (rel. int., %) = 491.4 (100) [M-H]⁻.

HR-MS (ESI, positive mode): 493.1933 [M+H]⁺ (found), 493.1933 (calculated for C₂₈H₂₇F₂N₂O₄, [M+H]⁺).

HR-MS (ESI, negative mode): 491.1790 [M-H]⁻ (found), 491.1788 (calculated for C₂₈H₂₅F₂N₂O₄, [M-H]⁻).

UV-Vis (PBS, pH 7.4): absorption, λ_{max}, nm (ε, M⁻¹cm⁻¹): 628 (6700); emission, λ_{max}, nm (Φ): 660 (0.06).

The tagged derivative **1h-Halo** was prepared as follows:

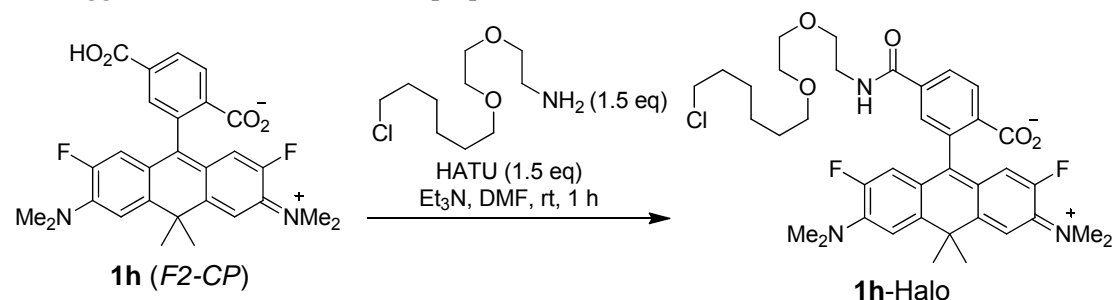

HATU (14 μL of 25 mg/100 μL stock solution, 9.14 μmol, 1.5 equiv) was added to a solution of **1h** (3 mg, 6.09 μmol), HaloTag Amine (O2) (2-(2-((6-chlorohexyl)oxy)ethoxy)ethanamine,^[S13] 2 mg, 9.13 μmol, 1.5 equiv) and triethylamine (8.5 μL) in DMF (100 μL). After 1 h, the solvent was evaporated *in vacuo* at rt, and the product was isolated by preparative TLC (silica, 5% methanol – CH₂Cl₂) giving the material with ~80% purity, from which pure **1h-Halo** was isolated by preparative HPLC. Yield 1.2 mg (28%) of white solid.

¹H NMR (400 MHz, CDCl₃): δ 8.06 (dd, *J* = 7.9, 0.7 Hz, 1H), 7.93 (dd, *J* = 8.0, 1.4 Hz, 1H), 7.49 – 7.43 (dd, *J* = 1.3, 0.7 Hz, 1H), 7.00 (d, *J* = 8.8 Hz, 2H), 6.82 (br.t, *J* = 4.8 Hz, 1H), 6.28 (d, *J* = 13.9 Hz, 2H), 3.67 – 3.57 (m, 6H), 3.58 – 3.47 (m, 4H), 3.40 (t, *J* = 6.7 Hz, 2H), 2.90 (s, 12H), 1.83 (s, 3H), 1.80 – 1.68 (m, 2H), 1.73 (s, 3H), 1.57 – 1.47 (m, 2H), 1.46 – 1.37 (m, 2H), 1.37 – 1.24 (m, 2H).

¹⁹F NMR (283 MHz, CDCl₃): δ -124.02.

^{13}C NMR (101 MHz, CDCl_3): δ 127.9, 125.5, 122.9, 115.4, 114.4, 71.2, 70.2, 69.9, 69.5, 44.9, 42.5, 40.0, 35.1, 33.7, 32.6, 30.9, 29.1, 26.7, 25.2 (indirect detection from HSQC experiment; only H-coupled carbons are resolved).

ESI-MS, positive mode: m/z (rel. int., %) = 698.3 (100) $[\text{M}+\text{H}]^+$.

HR-MS (ESI, positive mode): 698.3167 $[\text{M}+\text{H}]^+$ (found), 698.3167 (calculated for $\text{C}_{38}\text{H}_{47}\text{ClF}_2\text{N}_3\text{O}_5$, $[\text{M}+\text{H}]^+$).

HPLC (1.2 mL/min, gradient A:B = 30:70 \rightarrow 100:0 over 25 min, detection at 254 nm): $t = 19.20$ min.

Gradient : A% = 30 B% = 70 ----> A% = 100 B% = 0 T = 20 Min.

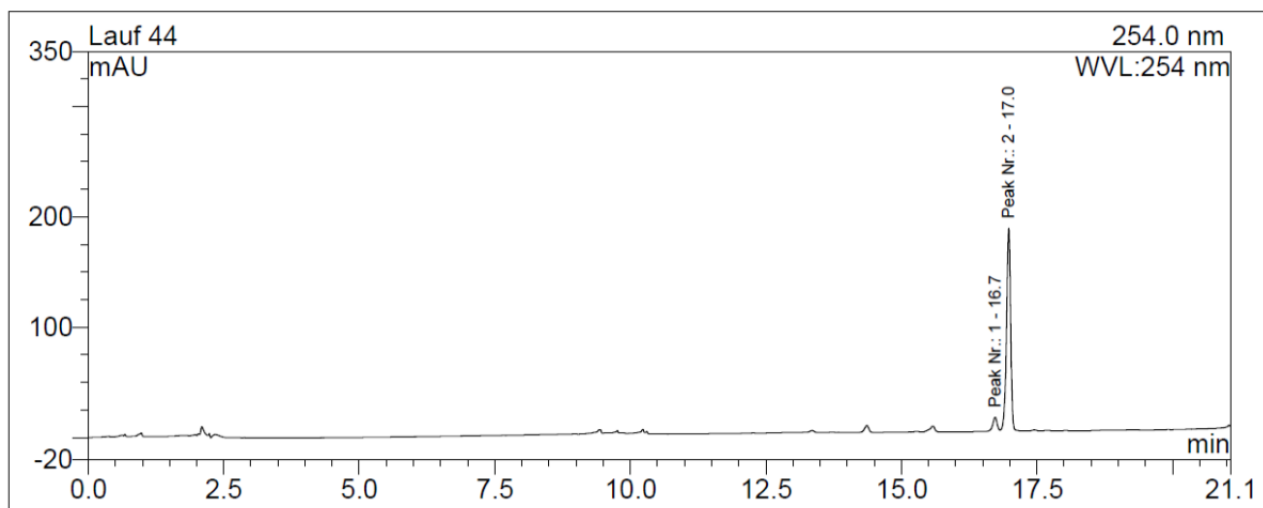

Fluorescent dye *SiR* (**1i**)

The dye **1i** (*SiR*) and its tagged derivative **1i-Halo** were prepared according to the reported procedure.^[S4]

Fluorescent dye *650SiR* (**1j**)

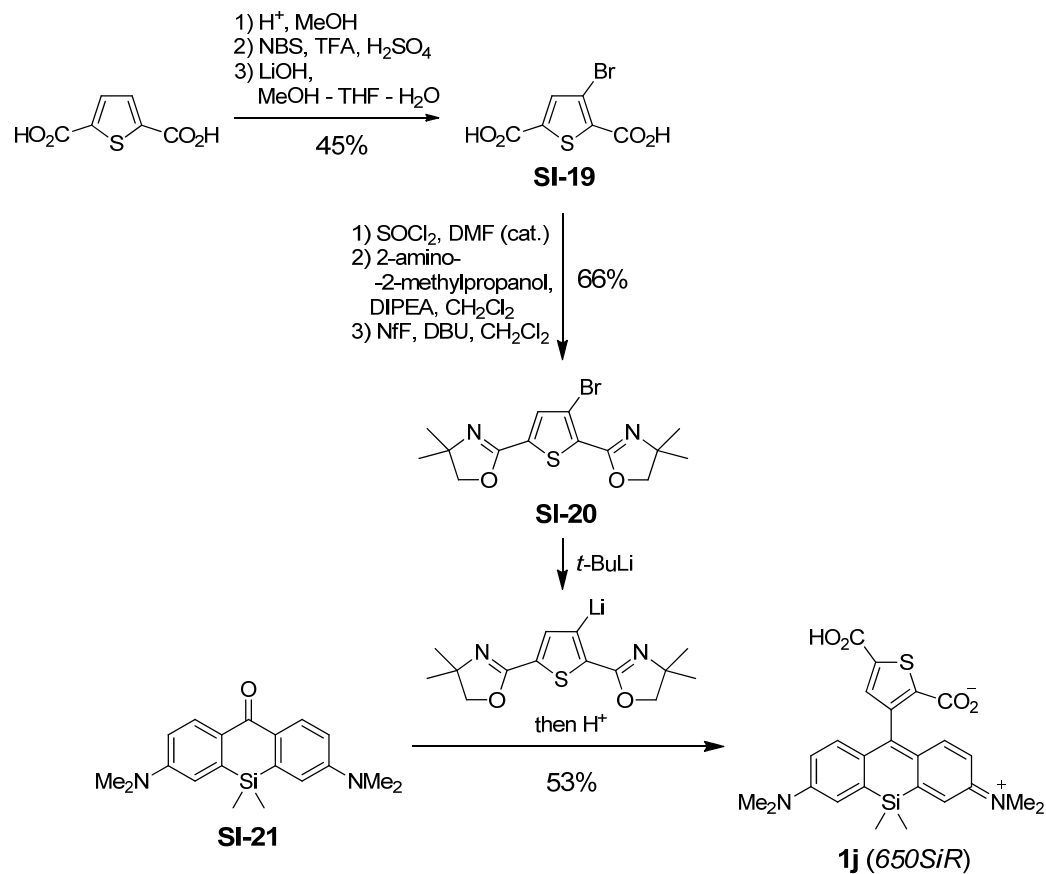

SI-17^[S14]

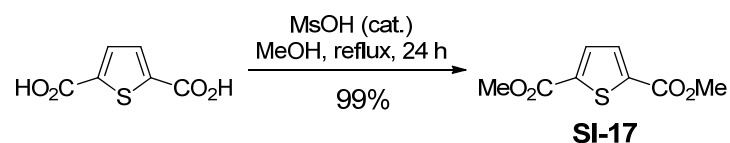

Methanesulfonic acid (0.35 mL) was added to a suspension of 2,5-thiophenedicarboxylic acid (2.25 g, 13.08 mmol) in methanol (15 mL), and the mixture was refluxed for 24 h (clear solution formed within 1 h, followed by precipitation of the product). The resulting suspension was allowed to cool down to rt, then cooled in dry ice-acetone bath, the crystalline product was filtered off, washed with cold (-78° C) methanol and methanol-water. The solid was dried in air, yield 2.58 g (99%).

¹H NMR (400 MHz, CDCl₃): δ 7.73 (s, 2H), 3.91 (s, 6H).

SI-18

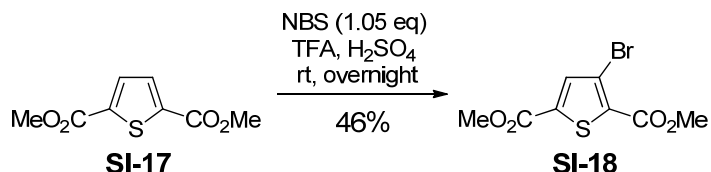

Solid NBS (2.4 g, 13.48 mmol, 1.05 equiv) was added portionwise over 1 h to a solution of **SI-17** (2.58 g, 12.90 mmol) in a mixture of trifluoroacetic acid (6.5 mL) and conc. H₂SO₄ (2.6 mL); the reaction is mildly exothermic. The resulting thin orange suspension was stirred at rt overnight, poured on ice (100 mL), extracted with CH₂Cl₂ (3×50 mL), the combined organic layers were washed with sat. aq. NaHCO₃ (2×50 mL), brine and dried over Na₂SO₄. The product was isolated by flash column chromatography (100 g silica, gradient 50% to 100% CH₂Cl₂ – hexane). The fractions containing the product were pooled, evaporated and the residue was recrystallized from CH₂Cl₂ – hexane (with cooling in ice-water bath). The resulting material (2.55 g, purity 85%) was repurified by flash column chromatography (same conditions) yielding 1.64 g (46%) of the product (purity 95%).

¹H NMR (400 MHz, CDCl₃): δ 7.70 (s, 1H), 3.920 (s, 3H), 3.916 (s, 3H).

¹³C NMR (101 MHz, CDCl₃): δ 161.2, 160.8, 137.6, 137.3, 132.5, 116.6, 53.0, 52.8.

ESI-MS, positive mode: *m/z* (rel. int., %) = 280.9 [M+H, ⁸¹Br]⁺.

HR-MS (ESI, positive mode): 278.9315 [M+H, ⁷⁹Br]⁺ (found), 278.9321 (calculated for C₈H₈BrO₄S, [M+H, ⁷⁹Br]⁺).

SI-19

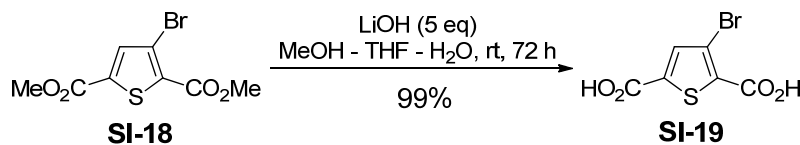

A solution of LiOH·H₂O (1.23 g, 29.31 mmol, 5 equiv) in water (10 mL) was added to **SI-18** (1.63 g, 5.84 mmol; purity ~95%), dissolved in methanol (10 mL) and THF (30 mL), and the resulting mixture was stirred at rt for 3 days. Methanol and THF were removed on a rotavapor, the residue was diluted with 0.1 N NaOH and filtered through a plug of Celite (washing with 0.1 N NaOH). The filtrate was acidified with 6 N HCl, left to crystallize in ice-water bath for 2 h, the crystals were filtered off and washed with ice-cold water and diethyl ether – hexane (1:1). Upon drying *in vacuo*, 1.46 g (99%) of the product was obtained as light tan solid.

¹H NMR (400 MHz, DMSO-*d*₆): δ 7.73 (s, 1H), 3.90 (br.s, 2H).

¹³C NMR (101 MHz, DMSO-*d*₆): δ 161.5, 161.1, 138.5, 136.9, 133.4, 115.2.

ESI-MS, negative mode: *m/z* (rel. int., %) = 248.9 [M-H, ⁷⁹Br]⁻.

HR-MS (ESI, positive mode): 294.8646 [M+2Na, ⁷⁹Br]⁺ (found), 294.8647 (calculated for C₆H₃BrO₄SNa₂, [M+2Na, ⁷⁹Br]⁺).

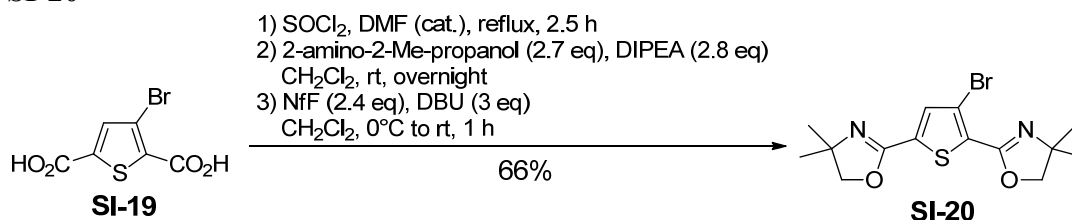
SI-20

The acid **SI-19** (1.04 g, 4.14 mmol) was mixed with thionyl chloride (8 mL), DMF (3 drops) was added and the suspension was refluxed for 2.5 h (the solids dissolved within 30 min). The mixture was evaporated to dryness, redissolved in CH₂Cl₂ (10 mL) and added dropwise to the solution of 2-amino-2-methyl-1-propanol (961 mg, 10.79 mmol, 2.7 equiv) and *N,N*-diisopropylethylamine (DIPEA; 2 mL, 1.48 g, 11.47 mmol, 2.4 equiv) in CH₂Cl₂ (20 mL). The resulting mixture was stirred at rt overnight, quenched with sat. aq. NaHCO₃ (30 mL), extracted with ethyl acetate (3×30 mL), the combined organic layers were washed with brine and dried over Na₂SO₄. The filtrate was evaporated and the crude diamide was used directly in the next step.

The residue was mixed with CH₂Cl₂ (30 mL) and 1,8-diazabicyclo[5.4.0]undec-7-ene (DBU; 1.8 mL, 1.83 g, 12.04 mmol, 3 equiv) was added. The resulting clear solution was cooled in ice-water bath, and perfluoro-1-butananesulfonyl fluoride (nonaflyl fluoride, NfF; 1.72 mL, 2.89 g, 9.57 mmol, 2.4 equiv) was added quickly dropwise. The mixture was allowed to warm up to rt and stirred for 1 h, followed by quenching with sat. aq. NaHCO₃ (30 mL) and extraction with CH₂Cl₂ (3×30 mL). The combined extracts were washed with brine, dried over Na₂SO₄, evaporated and the product was isolated by flash column chromatography (90 g silica, gradient 20% to 66% ethyl acetate – CH₂Cl₂). The fractions containing the product were evaporated and the residue was dried in vacuo to yield 944 mg (66%) of the crystalline **SI-20**.

¹H NMR (400 MHz, CDCl₃): δ 7.54 (s, 1H), 4.10 (s, 3H), 4.09 (s, 3H), 1.37 (s, 6H), 1.36 (s, 6H).

¹³C NMR (101 MHz, CDCl₃): δ 156.6, 156.2, 134.7, 132.7, 129.2, 113.0, 79.9, 79.5, 68.5, 68.4, 28.33, 28.28.

ESI-MS, positive mode: *m/z* (rel. int., %) = 357.0 [M+H, ⁷⁹Br]⁺.

HR-MS (ESI, positive mode): 357.0265 [M+H, ⁷⁹Br]⁺ (found), 357.0267 (calculated for C₁₄H₁₈BrN₂O₂S, [M+H, ⁷⁹Br]⁺).

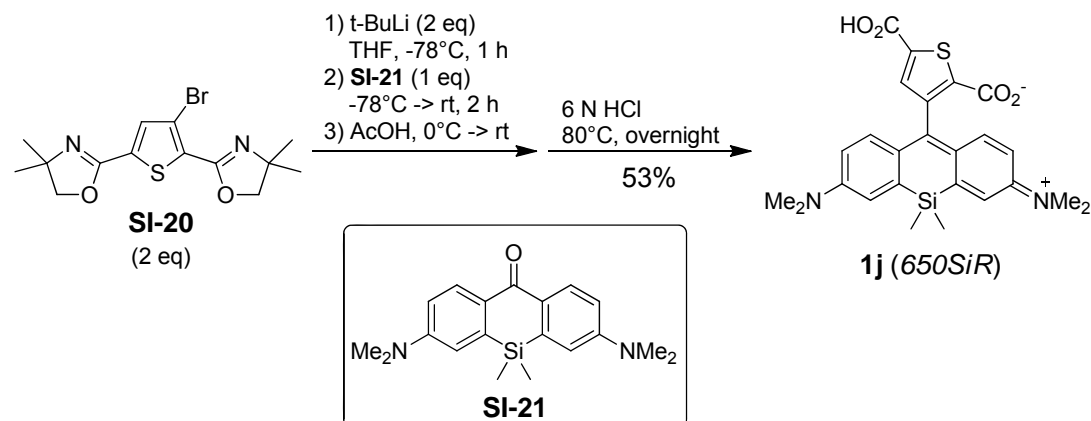
1j (650SiR)

To a solution of bis-oxazoline **SI-20** (179 mg, 0.50 mmol, 2 equiv) in THF (3 mL), cooled to -78°C, *t*-BuLi (0.3 mL of 1.7 M in pentane, 0.51 mmol, ~2 equiv) was added, and the mixture was stirred at to -78°C for 1 h. A solution of ketone **SI-21** (prepared according to reported procedure;^[S4] 81 mg, 0.25 mmol) in THF (5 mL) was then added dropwise, and the mixture was allowed to warm up to rt and stirred for 2 h. The resulting solution was cooled in ice-water bath, and acetic acid (1.2 mL) was added. The green reaction mixture was evaporated on a rotary evaporator (bath temperature 40°C) to a viscous residue, which was dissolved in 6 N HCl (15 mL), and the resulting orange solution was stirred at 80°C overnight. The brown mixture was poured on ice (20 g), and the pH was adjusted to 1-2 by careful addition of Na₂CO₃ and then NaHCO₃. The mixture was evaporated to dryness on a rotary evaporator and re-evaporated twice with acetone. The product was isolated from the crude residue by flash column chromatography (twice; 40 g silica, gradient 10% to 66% methanol – CH₂Cl₂), the fractions containing the product were pooled and evaporated, redissolved in aqueous 1,4-dioxane (1:1), the solution was centrifuged, the supernatant was microfiltered through a 0.45 μm PTFE membrane filter and lyophilized. Yield 63 mg (53%), dark turquoise solid.

¹H NMR (301 MHz, CD₃OD): δ 7.53 (s, 1H), 7.37 (s, 1H), 7.30 (d, *J* = 2.8 Hz, 2H), 7.27 (d, *J* = 9.6 Hz, 2H), 6.77 (dd, *J* = 9.6, 2.8 Hz, 2H), 3.49 (s, 6H), 3.33 (s, 6H), 0.59 (s, 6H).

¹³C NMR (126 MHz, CD₃OD): δ 168.8, 155.5, 149.2, 145.2, 142.5, 142.0, 134.1, 131.8, 129.1, 121.4, 114.8, 68.0, 56.2, 40.9, -1.0, -1.2.

ESI-MS, positive mode: *m/z* (rel. int., %) = 479.2 (100) [M+H]⁺.

HR-MS (ESI, positive mode): 479.1459 [M+H]⁺ (found), 479.1455 (calculated for C₂₅H₂₇N₂O₄SSi, [M+H]⁺).

UV-Vis (PBS, pH 7.4): absorption, λ_{max}, nm (ε, M⁻¹cm⁻¹): 650 (42000); emission, λ_{max}, nm (Φ): 672 (0.36).

The tagged derivative **1j**-Halo was prepared as follows:

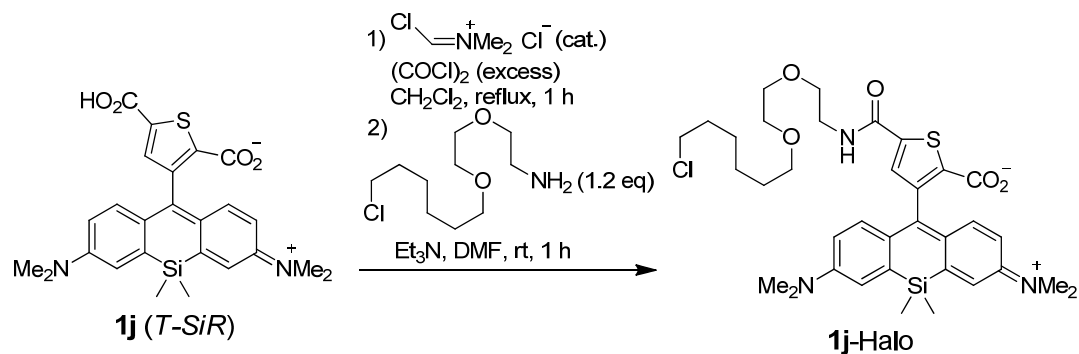

A crystal of (chloromethylene)dimethyliminium chloride (Vilsmeier reagent) was added to a mixture of **1j** (5 mg, 10.44 μmol) in a mixture of CH_2Cl_2 (2 mL) and oxalyl chloride (0.5 mL), and the resulting suspension was refluxed for 1 h (bath temperature 80 $^\circ\text{C}$), turning into a green solution. It was evaporated to dryness and a solution of HaloTag Amine (O2) (2-(2-((6-chlorohexyl)oxy)ethoxy)ethanamine; [^{13}C] 2.8 mg, 12.53 μmol , 1.2 equiv) and trimethylamine (10 μL) in CH_2Cl_2 (2 mL) was added to the residue. After stirring for 1 h at rt, water (2 mL) was added and the product was extracted with CH_2Cl_2 (2×10 mL). The combined extracts were dried over Na_2SO_4 , evaporated and the product was isolated by preparative TLC (silica, 20% methanol – CH_2Cl_2) giving a mixture, from which the major component **1j-Halo** was isolated by preparative HPLC. Yield 0.3 mg (4%) of blue solid.

ESI-MS, positive mode: m/z (rel. int., %) = 684.3 (100) $[\text{M}+\text{H}, ^{35}\text{Cl}]^+$.

HR-MS (ESI, positive mode): 684.2682 $[\text{M}+\text{H}, ^{35}\text{Cl}]^+$ (found), 684.2689 (calculated for $\text{C}_{35}\text{H}_{47}\text{ClN}_3\text{O}_5\text{SSi}$, $[\text{M}+\text{H}, ^{35}\text{Cl}]^+$).

HPLC (1.2 mL/min, gradient A:B = 30:70 \rightarrow 100:0 over 25 min, detection at 254 nm): $t = 13.92$ min.

Crude mixture from preparative TLC:

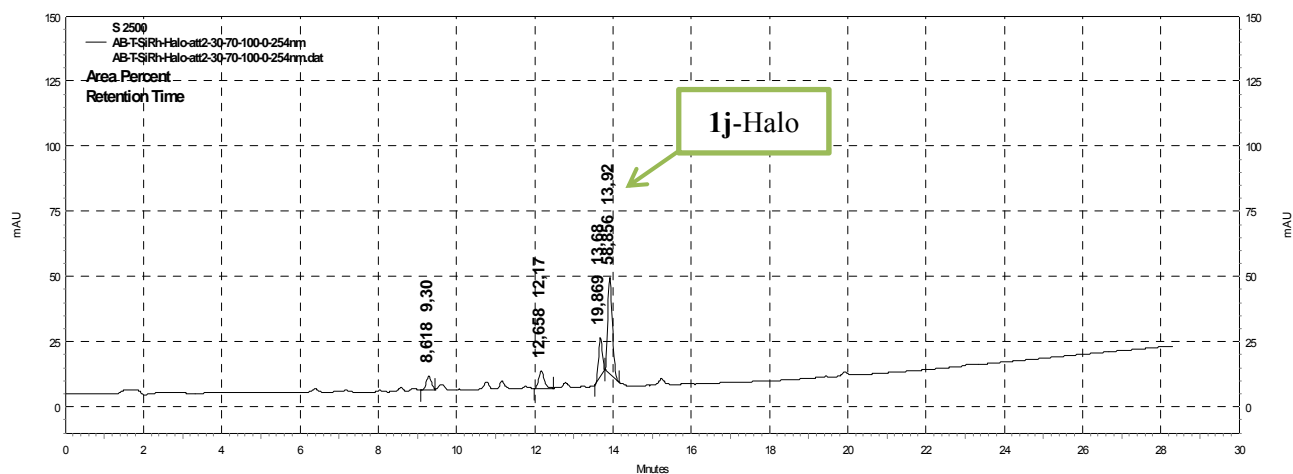

Purified material from preparative HPLC:

Gradient : A% = 30 B% = 70 ----> A% = 100 B% = 0 T = 20 Min.

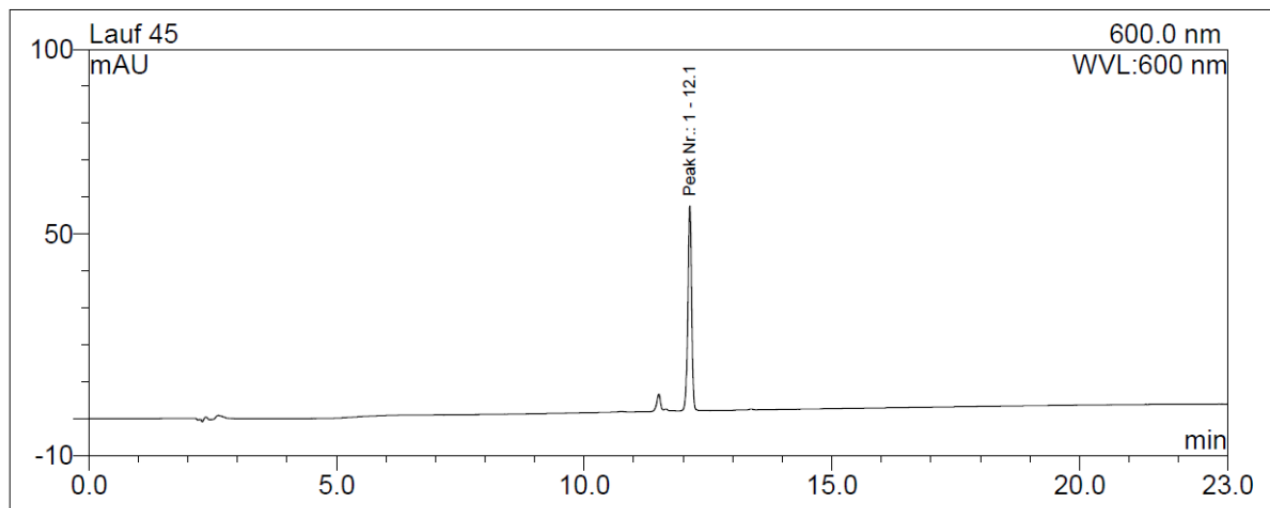

Fluorescent dye **670SiR** (**1k**)

Method 1:

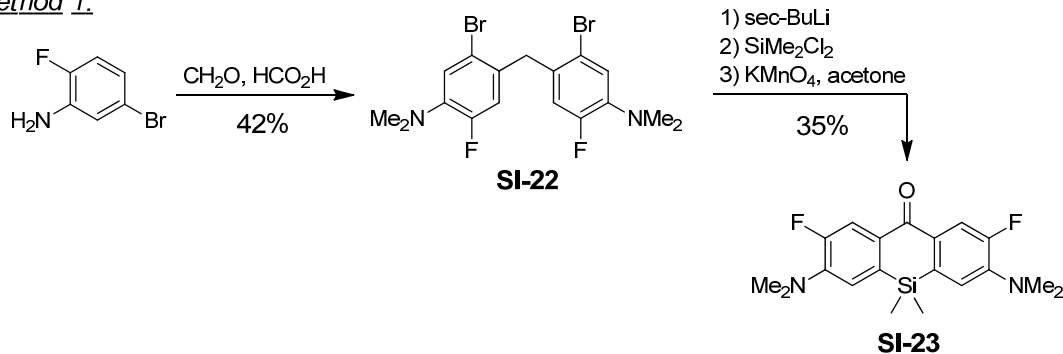

Method 2:

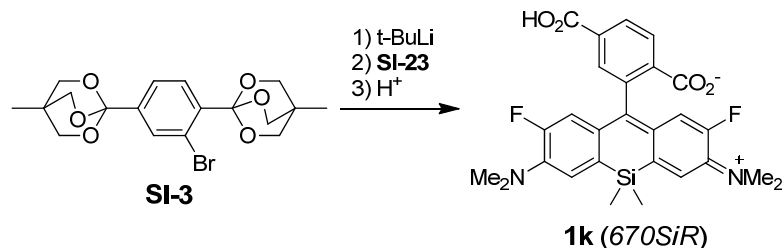
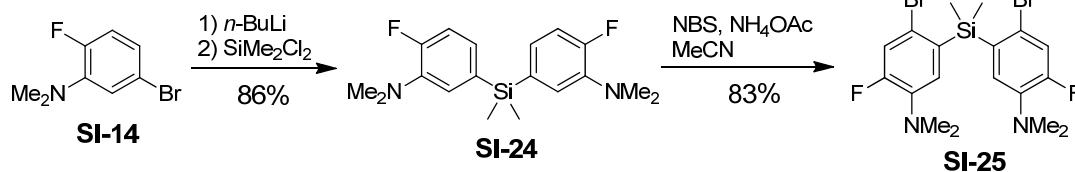

SI-22

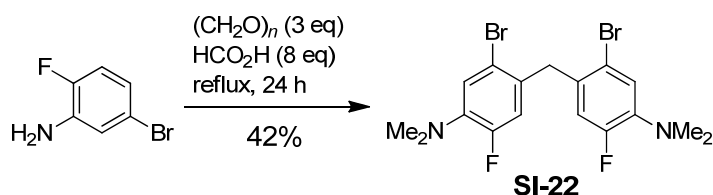

In a 25 mL round-bottom flask, equipped with a reflux condenser and bubbler, a mixture of 5-bromo-2-fluoroaniline (2.85 g, 15 mmol), paraformaldehyde (1.35 g, 45 mmol, 3 equiv) and 95% formic acid (5 mL, ~120 mmol, ~8 equiv) was refluxed for 24 h (bath temperature 105 °C). Upon cooling down to rt, the mixture was poured into sat. aq. NaHCO_3 (100 mL) and extracted with CH_2Cl_2 (3×50 mL). The combined organic layers were washed with brine and dried over Na_2SO_4 . The product was isolated by flash column chromatography (160 g silica; gradient 2% to 5% ethyl acetate – hexane). The fractions containing the product were evaporated and dried *in vacuo*. Viscous light yellow oil, yield 1.42 g (~80% purity, 42%). This material was used to prepare **SI-23** without additional purification.

On a small scale (1.5 mmol), the same reaction was run for 2 h in a glass tube, fitted with a septum and bubbler, and provided 127 mg (38%) of **SI-22** of somewhat better purity (~90%).

Pure **SI-22** could be prepared starting from the corresponding *N,N*-dimethylaniline (**SI-14**) by the following method:

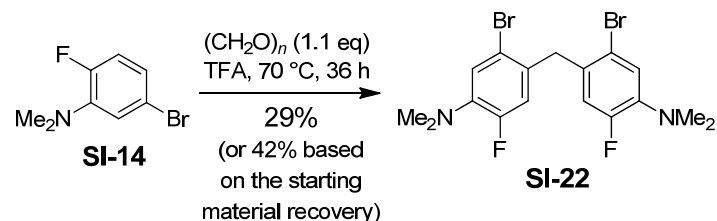

SI-14 (655 mg, 3 mmol) was dissolved in trifluoroacetic acid (2 mL). Paraformaldehyde (50 mg, 1.67 mmol, 0.55 equiv) was added, and the mixture was stirred at 70 °C (bath temperature) for 12 h. Another portion of paraformaldehyde (50 mg, 1.67 mmol, 0.55 equiv) was added, followed by heating at 70 °C for 24 h. The mixture was cooled down to rt, poured into sat. aq. NaHCO_3 (40 mL) and extracted with CH_2Cl_2 (4×15 mL). The combined organic layers were washed with brine and dried over Na_2SO_4 . The mixture was separated by flash column chromatography (30 g silica; gradient 2% to 5% ethyl acetate – hexane): R_f (**SI-14**) = 0.45, R_f (**SI-22**) = 0.25 (silica gel, 5% EtOAc – hexane). The product was obtained as viscous colorless oil, yield 195 mg (29%), along with 207 mg (32%) of recovered **SI-14**.

^1H NMR (400 MHz, CDCl_3): δ 7.06 (d, J = 8.4 Hz, 2H), 6.68 (d, J = 13.7 Hz, 2H), 3.97 (s, 2H), 2.84 (s, 12H).

^{13}C NMR (101 MHz, CDCl_3): δ 154.1 (d, J = 245.9 Hz), 140.4 (d, J = 9.7 Hz), 131.1 (d, J = 6.9 Hz), 122.0 (d, J = 3.9 Hz), 118.8 (d, J = 3.0 Hz), 117.9 (d, J = 23.0 Hz), 42.7 (d, J = 4.4 Hz), 40.4 (t, J = 1.1 Hz).

^{19}F NMR (376 MHz, CDCl_3): δ -123.49.

ESI-MS, positive mode: m/z (rel. int., %) = 449.0 (100) $[\text{M}+\text{H}, ^{79}\text{Br}+^{81}\text{Br}]^+$.

HR-MS (ESI, positive mode): 446.9873 $[\text{M}+\text{H}, 2\times^{79}\text{Br}]^+$ (found), 446.9878 (calculated for $\text{C}_{17}\text{H}_{19}\text{Br}_2\text{F}_2\text{N}_2$, $[\text{M}+\text{H}, 2\times^{79}\text{Br}]^+$).

SI-23 (from SI-22)

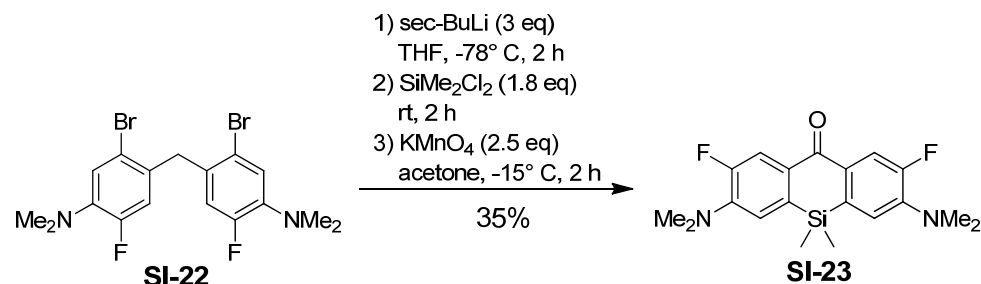

sec-Butyllithium (6.7 mL of 1.4 M in cyclohexane, 9.39 mmol, 3 equiv) was added quickly dropwise to a solution of **SI-22** (~80% purity; 1.4 g, 3.13 mmol) in anhydrous THF (120 mL), cooled to -78 °C. The

resulting bright yellow solution was stirred at $-78\text{ }^{\circ}\text{C}$ for 2 h, eventually turning light yellow. Dichlorodimethylsilane (680 μL , 5.63 mmol, 1.8 equiv) was then added dropwise at $-78\text{ }^{\circ}\text{C}$, the mixture was allowed to warm up to rt and stirred for further 2 h. 1 N HCl (10 drops) was added to neutralize the mixture, and THF was evaporated from the resulting suspension on a rotary evaporator. The residue was mixed with sat. aq. NaHCO_3 (80 mL) and extracted with ethyl acetate ($3\times 50\text{ mL}$), the combined extracts were dried over Na_2SO_4 , filtered and evaporated. The residue was dissolved in acetone (45 mL), cooled to $-15\text{ }^{\circ}\text{C}$ (dry ice/2-propanol: H_2O 1:1 bath), and pulverized KMnO_4 (1.21 g, 7.66 mmol, ~ 2.5 equiv) was added portionwise over 20 min. The resulting suspension was stirred at $-15\text{ }^{\circ}\text{C}$ for 2 h, quenched by dilution with cold ($-78\text{ }^{\circ}\text{C}$) CH_2Cl_2 (100 mL), followed by addition of Celite and filtration (the filter cake was washed with additional cold CH_2Cl_2). The filtrate was evaporated and the product was isolated by flash column chromatography (110 g silica; gradient 10% to 18% ethyl acetate – hexane). The fractions containing the product were evaporated and the residue was recrystallized from CH_2Cl_2 – hexane. Bright yellow crystals, yield 392 mg (35%).

^1H NMR (400 MHz, CDCl_3): δ 8.07 (d, $J = 16.3\text{ Hz}$, 2H), 6.89 (d, $J = 9.5\text{ Hz}$, 2H), 3.05 (d, $J = 1.5\text{ Hz}$, 12H), 0.45 (s, 6H).

^{13}C NMR (101 MHz, CDCl_3): δ 183.9 (d, $J = 1.9\text{ Hz}$), 154.9 (d, $J = 247.2\text{ Hz}$), 143.3 (d, $J = 8.0\text{ Hz}$), 136.0 (d, $J = 3.5\text{ Hz}$), 133.1 (dd, $J = 5.6, 1.4\text{ Hz}$), 120.1 (d, $J = 3.8\text{ Hz}$), 117.6 (d, $J = 21.7\text{ Hz}$), 42.4 (d, $J = 5.6\text{ Hz}$), -0.9 .

^{19}F NMR (376 MHz, CDCl_3): δ -120.44 .

ESI-MS, positive mode: m/z (rel. int., %) = 361.2 (100) $[\text{M}+\text{H}]^+$.

HR-MS (ESI, positive mode): 361.1546 $[\text{M}+\text{H}]^+$ (found), 361.1542 (calculated for $\text{C}_{19}\text{H}_{23}\text{F}_2\text{N}_2\text{OSi}$, $[\text{M}+\text{H}]^+$).

SI-24

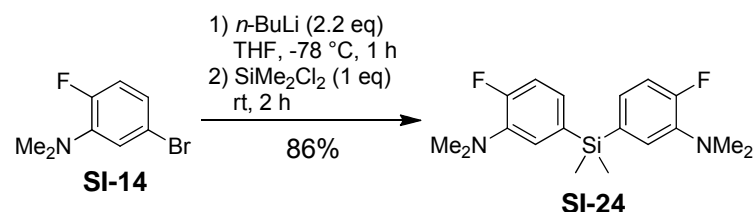

n -Butyllithium (3 mL of 2.5 M in hexanes, 7.57 mmol, 2.2 equiv) was added quickly dropwise to a cold ($-78\text{ }^{\circ}\text{C}$) solution of **SI-14** (1.5 g, 6.88 mmol) in anhydrous THF (30 mL). The mixture was stirred at $-78\text{ }^{\circ}\text{C}$ for 1 h, and dichlorodimethylsilane (420 μL , 3.44 mmol, 1 equiv) was added quickly dropwise at $-78\text{ }^{\circ}\text{C}$. The resulting mixture was stirred at rt for 2 h. It was then quenched with water (10 mL) and brine (25 mL), extracted with ethyl acetate ($4\times 40\text{ mL}$) and the combined extracts were dried over Na_2SO_4 . The product was isolated by flash column chromatography (40 g silica; gradient 5% to 20% ethyl acetate – hexane). Yield 990 mg (86%), colorless oil.

^1H NMR (400 MHz, CDCl_3): δ 7.06 – 6.99 (m, 6H), 2.83 (s, 12H), 0.53 (s, 6H).

^{13}C NMR (101 MHz, CDCl_3): δ 156.3 (d, $J = 248.0$ Hz), 140.3 (d, $J = 8.0$ Hz), 134.0 (d, $J = 4.3$ Hz), 127.6 (d, $J = 7.4$ Hz), 124.0 (d, $J = 3.4$ Hz), 115.9 (d, $J = 19.9$ Hz), 43.0 (d, $J = 3.9$ Hz), -1.86.

^{19}F NMR (376 MHz, CDCl_3): δ -121.36.

ESI-MS, positive mode: m/z (rel. int., %) = 335.3 (100) $[\text{M}+\text{H}]^+$.

HR-MS (ESI, positive mode): 335.1752 $[\text{M}+\text{H}]^+$ (found), 335.1750 (calculated for $\text{C}_{18}\text{H}_{25}\text{F}_2\text{N}_2\text{Si}$, $[\text{M}+\text{H}]^+$).

SI-25

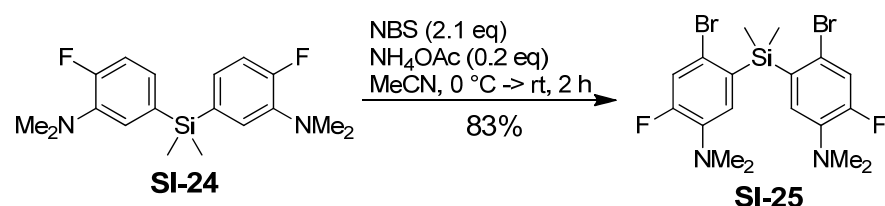

N-Bromosuccinimide (781 mg, 4.39 mmol, 2.1 equiv) was added in small portions to a mixture of **SI-24** (698 mg, 2.09 mmol) and ammonium acetate (32 mg, 0.42 mmol, 0.2 equiv) in acetonitrile (9 mL), cooled in ice-water bath. Yellow color appeared upon addition of each portion and faded quickly; finally, the solution remained light yellow. The mixture was stirred for further 30 min at $0\text{ }^\circ\text{C}$, turning into a thin suspension, which was stirred for further 2 h at rt. Sat. aq. NaHCO_3 (30 mL) was then added, and the reaction mixture was extracted with CH_2Cl_2 (3×30 mL), the combined extracts were washed with brine and dried over Na_2SO_4 . The product was isolated by flash column chromatography (35 g silica; gradient 70% to 100% CH_2Cl_2 – hexane, followed by 5% to 10% ethyl acetate – CH_2Cl_2). Yield 852 mg (83%), viscous yellowish oil, crystallizing slowly to white solid.

^1H NMR (400 MHz, CDCl_3): δ 7.20 (d, $J = 12.4$ Hz, 2H), 6.94 (d, $J = 10.2$ Hz, 2H), 2.80 (s, 12H), 0.74 (s, 6H).

^{13}C NMR (101 MHz, CDCl_3): δ 155.6 (d, $J = 252.7$ Hz), 139.4 (d, $J = 7.6$ Hz), 134.1 (d, $J = 4.0$ Hz), 126.7 (d, $J = 4.0$ Hz), 120.9 (d, $J = 23.5$ Hz), 119.9 (d, $J = 8.8$ Hz), 42.7 (d, $J = 4.1$ Hz), -0.79.

^{19}F NMR (376 MHz, CDCl_3): δ -118.91.

ESI-MS, positive mode: m/z (rel. int., %) = 493.2 (100) $[\text{M}+\text{H}, ^{79}\text{Br}+^{81}\text{Br}]^+$.

HR-MS (ESI, positive mode): 490.9953 $[\text{M}+\text{H}, 2 \times ^{79}\text{Br}]^+$ (found), 490.9960 (calculated for $\text{C}_{18}\text{H}_{23}\text{Br}_2\text{F}_2\text{N}_2\text{Si}$, $[\text{M}+\text{H}, 2 \times ^{79}\text{Br}]^+$).

SI-23 (from SI-25)

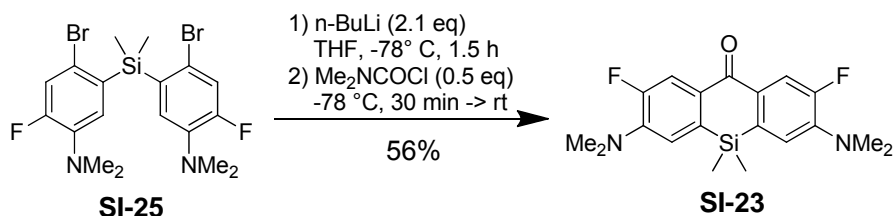

n-Butyllithium (0.42 mL of 2.5 M in hexanes, 1.05 mmol, 2.1 equiv) was added quickly dropwise to a cold (-78 °C) solution of **SI-25** (284 mg, 0.50 mmol) in anhydrous THF (10 mL). The resulting light yellow solution was stirred at -78 °C for 1.5 h. Neat *N,N*-dimethylcarbonyl chloride (23 μL, 0.25 mmol, 0.5 equiv) was then injected dropwise with a Hamilton syringe. The resulting mixture was stirred at -78 °C for 30 min, then allowed to warm up to rt and quenched with sat. aq. NH₄Cl (10 mL). Water was added to dissolve solids, and the mixture was extracted with ethyl acetate (3×20 mL). The combined extracts were dried over Na₂SO₄, filtered, and the product was isolated by flash column chromatography (20 g silica; gradient 10% to 20% ethyl acetate – hexane) to give 100 mg (56%) of the ketone **SI-23** as bright yellow solid (see above for the analytical data).

1k (670SiR)

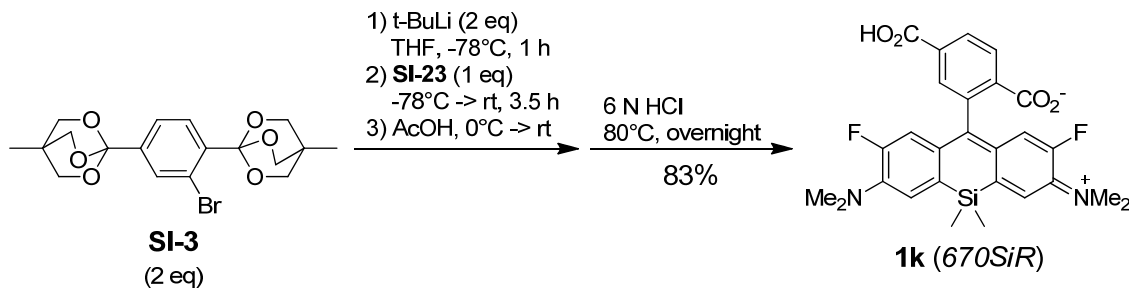

tert-Butyllithium (0.33 mL of 1.7 M in pentane, 0.56 mmol, 2 equiv) was added dropwise to a cold (-78 °C) solution of **SI-3** (231 mg, 0.56 mmol, 2 equiv) in THF (10 mL). The resulting brown-orange solution was stirred at -78 °C for 1 h, turning orange-yellow. A solution of ketone **SI-23** in THF (8 mL) was then added quickly dropwise, the reaction mixture was allowed to warm up to rt and stirred for 3.5 h. Upon cooling in ice-water bath, the mixture was quenched by addition of acetic acid (1.4 mL), and the resulting suspension was evaporated to blue-green viscous residue. This material was dissolved in 6 N HCl (16 mL) and stirred at 80 °C (bath temperature) overnight, during which time the dark orange solution turned into a light tan suspension. The mixture was cooled down to rt, and its pH was adjusted to 1-2 by addition of Na₂CO₃, NaHCO₃ and (if necessary) 1 N HCl. The mixture was extracted with CH₂Cl₂ (4×40 mL), the combined organic layers were washed with 0.1 N HCl (100 mL), brine and dried over Na₂SO₄. The product was isolated by flash column chromatography (35 g silica; gradient 5% to 20% methanol – CH₂Cl₂) giving a crude material, which was repurified by flash chromatography on a reversed phase (12 g RP-C₁₈, gradient 50% to 10% H₂O – acetonitrile). The fractions containing the product were evaporated to dryness, reevaporated with acetone, the residue was dissolved in 1,4-dioxane and microfiltered through a 0.45 μm PTFE membrane filter. The filtrate was lyophilized to give 142 mg (83%) of the product as light green fluffy solid.

^1H NMR (400 MHz, CD_3OD): δ 8.20 (d, $J = 8.0$ Hz, 1H), 8.01 (d, $J = 7.9$ Hz, 1H), 7.81 (s, 1H), 7.22 (d, $J = 9.9$ Hz, 2H), 6.63 (d, $J = 15.5$ Hz, 2H), 2.86 (d, $J = 0.9$ Hz, 12H), 0.70 (s, 3H), 0.56 (s, 3H).

^{13}C NMR (101 MHz, CD_3OD): δ 171.4, 156.7 (d, $J = 247.6$ Hz), 156.4, 141.8 (d, $J = 7.8$ Hz), 137.5 (d, $J = 6.2$ Hz), 132.2 (d, $J = 3.9$ Hz), 131.8, 128.5, 126.9, 125.5, 124.0 (d, $J = 3.9$ Hz), 115.2 (d, $J = 22.7$ Hz), 42.8 (d, $J = 4.4$ Hz), 0.0, -0.5.

^{19}F NMR (376 MHz, CD_3OD): δ -120.40.

ESI-MS, positive mode: m/z (rel. int., %) = 509.3 (100) $[\text{M}+\text{H}]^+$. ESI-MS, negative mode: m/z (rel. int., %) = 507.4 (100) $[\text{M}-\text{H}]^-$.

HR-MS (ESI, positive mode): 509.1703 $[\text{M}+\text{H}]^+$ (found), 509.1703 (calculated for $\text{C}_{27}\text{H}_{27}\text{F}_2\text{N}_2\text{O}_4\text{Si}$, $[\text{M}+\text{H}]^+$).

UV-Vis (PBS, pH 7.4): absorption, λ_{max} , nm (ϵ , $\text{M}^{-1}\text{cm}^{-1}$): 670 (150); emission, λ_{max} , nm (Φ): 696 (0.03).

The tagged derivative **1k-Halo** was prepared as follows:

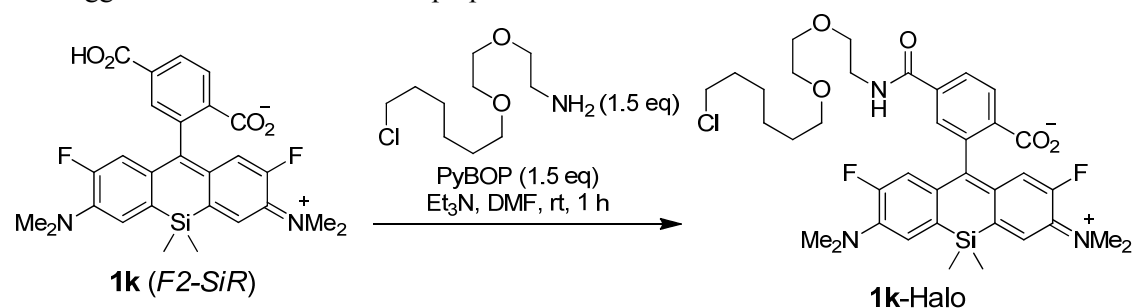

PyBOP (20 μL of 27 mg/100 μL stock solution, 10.33 μmol , 1.5 equiv) was added to a solution of **1k** (3.5 mg, 6.89 μmol), HaloTag Amine (O2) (2-(2-((6-chlorohexyl)oxy)ethoxy)ethanamine,^[S13] 2.3 mg, 10.33 μmol , 1.5 equiv) and triethylamine (10 μL) in DMF (100 μL). After 1 h, the solvent was evaporated *in vacuo* at rt, and the product was isolated by preparative TLC (silica, 2% methanol – CH_2Cl_2) giving **1k-Halo** with 98% purity, which was redissolved in 1,4-dioxane, microfiltered through a 0.2 μm PTFE membrane filter and lyophilized. Yield 1.5 mg (30%) of white solid.

^1H NMR (400 MHz, CDCl_3): δ 8.01 (dd, $J = 8.0, 0.7$ Hz, 1H), 7.87 (dd, $J = 8.0, 1.3$ Hz, 1H), 7.66 (dd, $J = 1.4, 0.7$ Hz, 1H), 7.06 (d, $J = 9.8$ Hz, 2H), 6.84 (br.t, $J = 5.6$ Hz, 1H), 6.63 (d, $J = 15.3$ Hz, 2H), 3.68 – 3.60 (m, 6H), 3.57 – 3.53 (m, 2H), 3.50 (t, $J = 6.7$ Hz, 2H), 3.40 (t, $J = 6.7$ Hz, 2H), 2.89 (s, 12H), 1.79 – 1.67 (m, 2H), 1.52 (p, $J = 6.9$ Hz, 2H), 1.45 – 1.24 (m, 4H), 0.68 (s, 3H), 0.56 (s, 3H).

^{19}F NMR (283 MHz, CDCl_3): δ -118.86.

^{13}C NMR (101 MHz, CDCl_3): δ 127.5, 126.3, 123.0, 122.3, 114.7, 71.2, 70.2, 69.4, 45.0, 42.4, 40.0, 32.5, 29.4, 26.7, 25.2, 0.1, -0.4 (indirect detection from HSQC experiment; only H-coupled carbons are resolved).

ESI-MS, positive mode: m/z (rel. int., %) = 714.3 (100) $[\text{M}+\text{H}]^+$.

HR-MS (ESI, positive mode): 714.2918 $[\text{M}+\text{H}]^+$ (found), 714.2936 (calculated for $\text{C}_{37}\text{H}_{47}\text{ClF}_2\text{N}_3\text{O}_5\text{Si}$, $[\text{M}+\text{H}]^+$).

HPLC (1.2 mL/min, gradient A:B = 30:70 → 100:0 over 25 min, detection at 254 nm): t = 20.92 min.

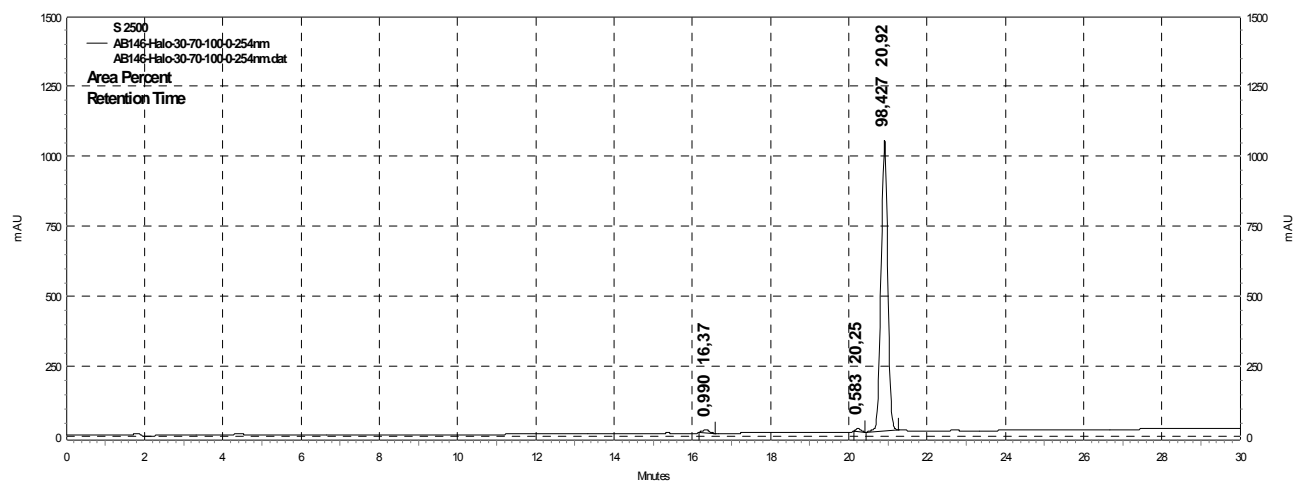

References

- [S1] C. Würth, M. Grabolle, J. Pauli, M. Spieles, U. Resch-Genger, *Nat. Protoc.* **2013**, *8*, 1535–1550.
- [S2] K. Rurack, M. Spieles, *Anal. Chem.* **2011**, *83*, 1232–1242.
- [S3] G. Lukinavičius, L. Reymond, E. D’Este, A. Masharina, F. Göttfert, H. Ta, A. Günther, M. Fournier, S. Rizzo, H. Waldmann, C. Blaukopf, C. Sommer, D. W. Gerlich, H.-D. Arndt, S. W. Hell, K. Johnsson, *Nat. Methods* **2014**, *11*, 731–733.
- [S4] G. Lukinavičius, K. Umezawa, N. Olivier, A. Honigmann, G. Yang, T. Plass, V. Mueller, L. Reymond, I. R. Corrêa Jr, Z.-G. Luo, C. Schultz, E. A. Lemke, P. Heppenstall, C. Eggeling, S. Manley, K. Johnsson, *Nat. Chem.* **2013**, *5*, 132–139.
- [S5] G. Y. Mitronova, V. N. Belov, M. L. Bossi, C. A. Wurm, L. Meyer, R. Medda, G. Moneron, S. Bretschneider, C. Eggeling, S. Jakobs, S. W. Hell, *Chem. Eur. J.* **2010**, *16*, 4477–4488.
- [S6] M.-K. So, H. Yao, J. Rao, *Biochem. Biophys. Res. Commun.* **2008**, *374*, 419–423.
- [S7] K. Kolmakov, C. A. Wurm, D. N. H. Meineke, F. Göttfert, V. P. Boyarskiy, V. N. Belov, S. W. Hell, *Chem. Eur. J.* **2014**, *20*, 146–157.
- [S8] J. B. Grimm, B. P. English, J. Chen, J. P. Slaughter, Z. Zhang, A. Revyakin, R. Patel, J. J. Macklin, D. Normanno, R. H. Singer, T. Lionnet, L. D. Lavis, *Nat. Meth.* **2015**, *12*, 244–250.
- [S9] J. B. Grimm, A. J. Sung, W. R. Legant, P. Hulamm, S. M. Matlosz, E. Betzig, L. D. Lavis, *ACS Chem. Biol.* **2013**, *8*, 1303–1310.
- [S10] A. Zilles, K.-H. Drexhage, N. U. Kemnitzer, J. Arden-Jacob, M. Hamers-Schneider, Patent WO 2012052435 A1.
- [S11] T. Pastierik, P. Šebej, J. Medalová, P. Štacko, P. Klán, *J. Org. Chem.* **2014**, *79*, 3374–3382.
- [S12] C. Wiles, P. Watts, S. J. Haswell, *Tetrahedron Lett.* **2006**, *47*, 5261–5264.
- [S13] V. Singh, S. Wang, E. T. Kool, *J. Am. Chem. Soc.* **2013**, *135*, 6184–6191.
- [S14] W. G. Skene, S. A. P. Guarin, *J. Fluoresc.* **2007**, *17*, 540–546.

NMR spectra of compounds 1a – 1k, SI-1 – SI-25

SI-1

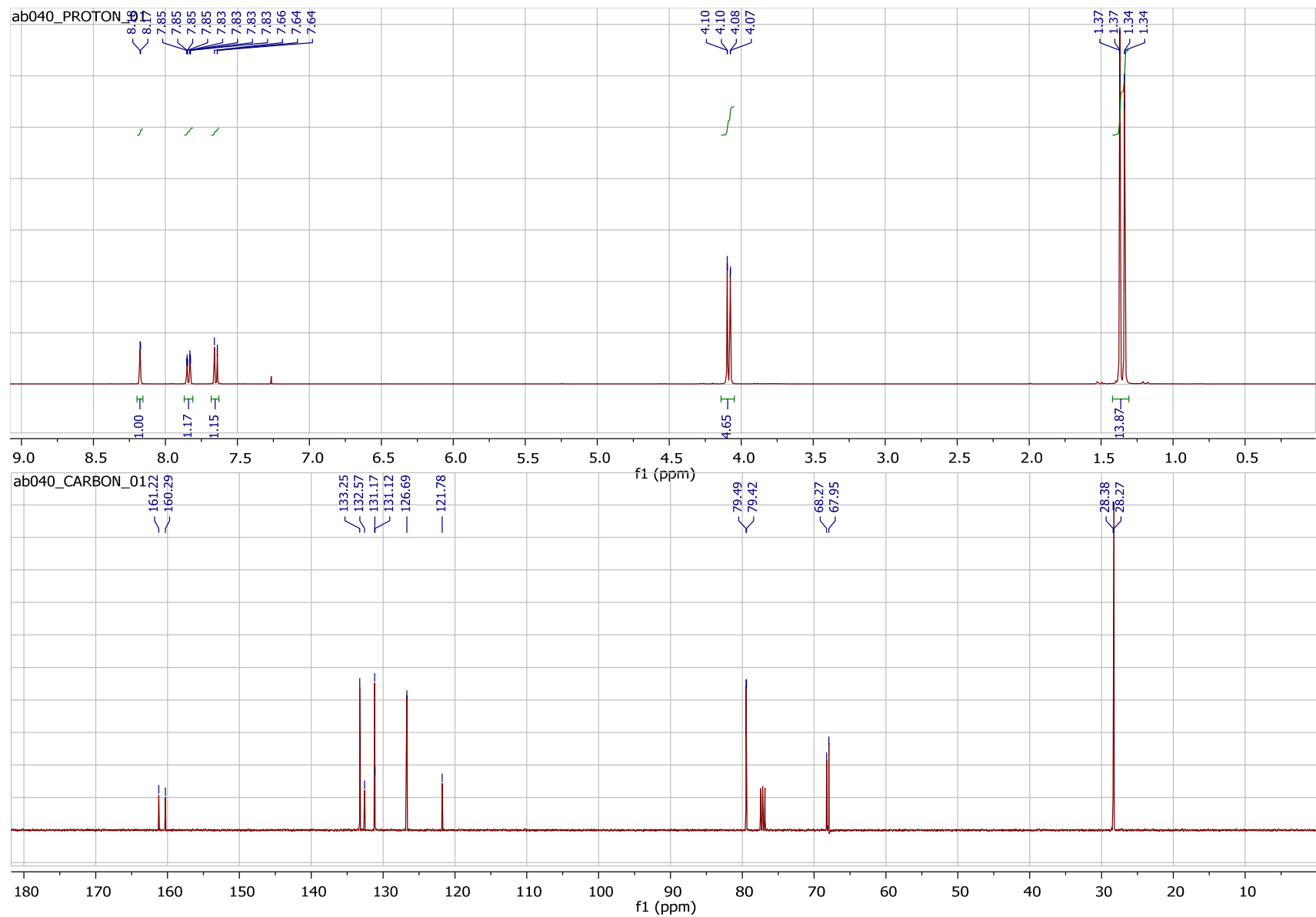

SI-2

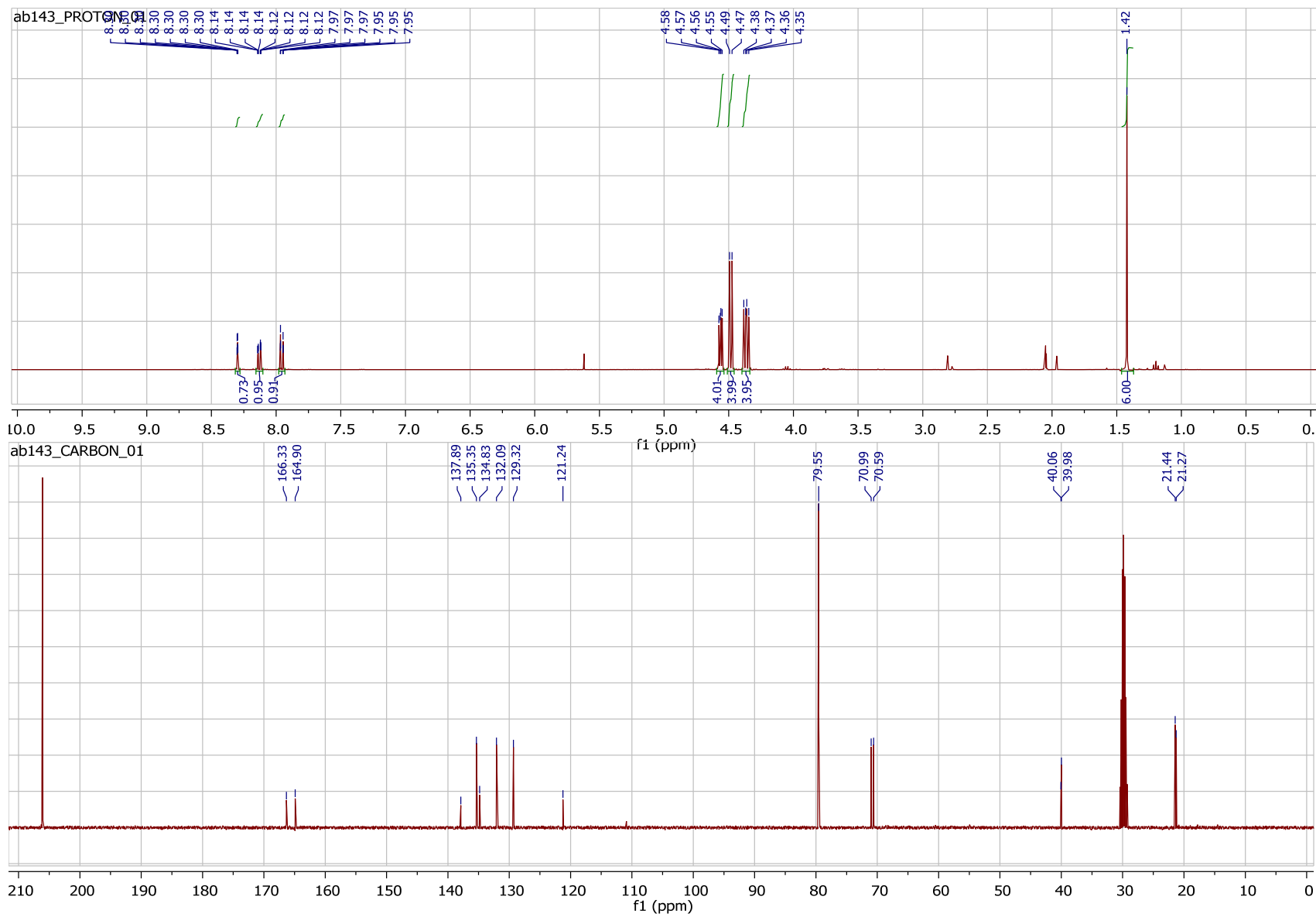

SI-3

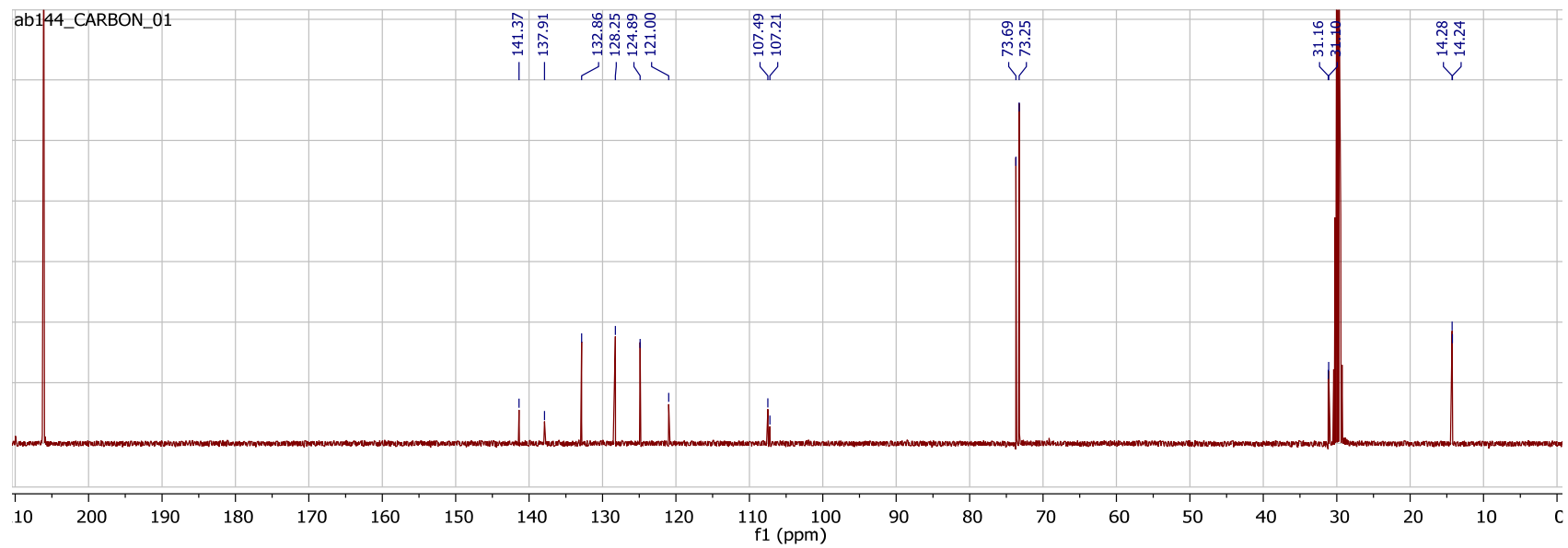
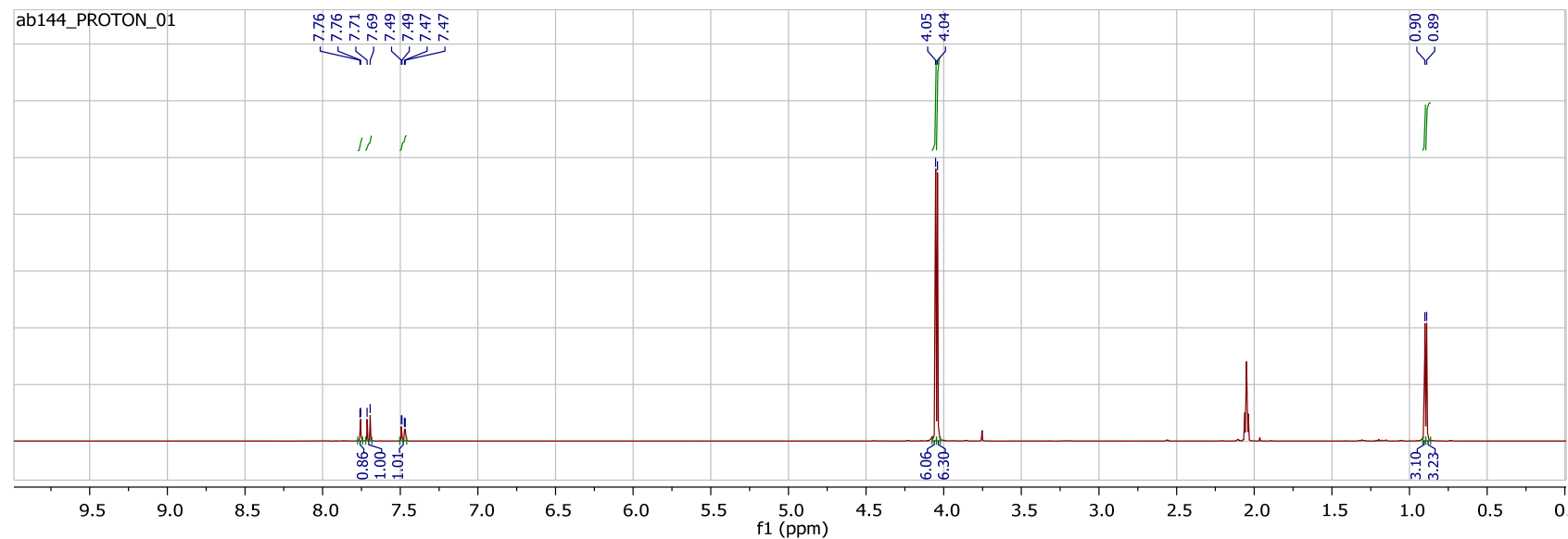

1a-Halo

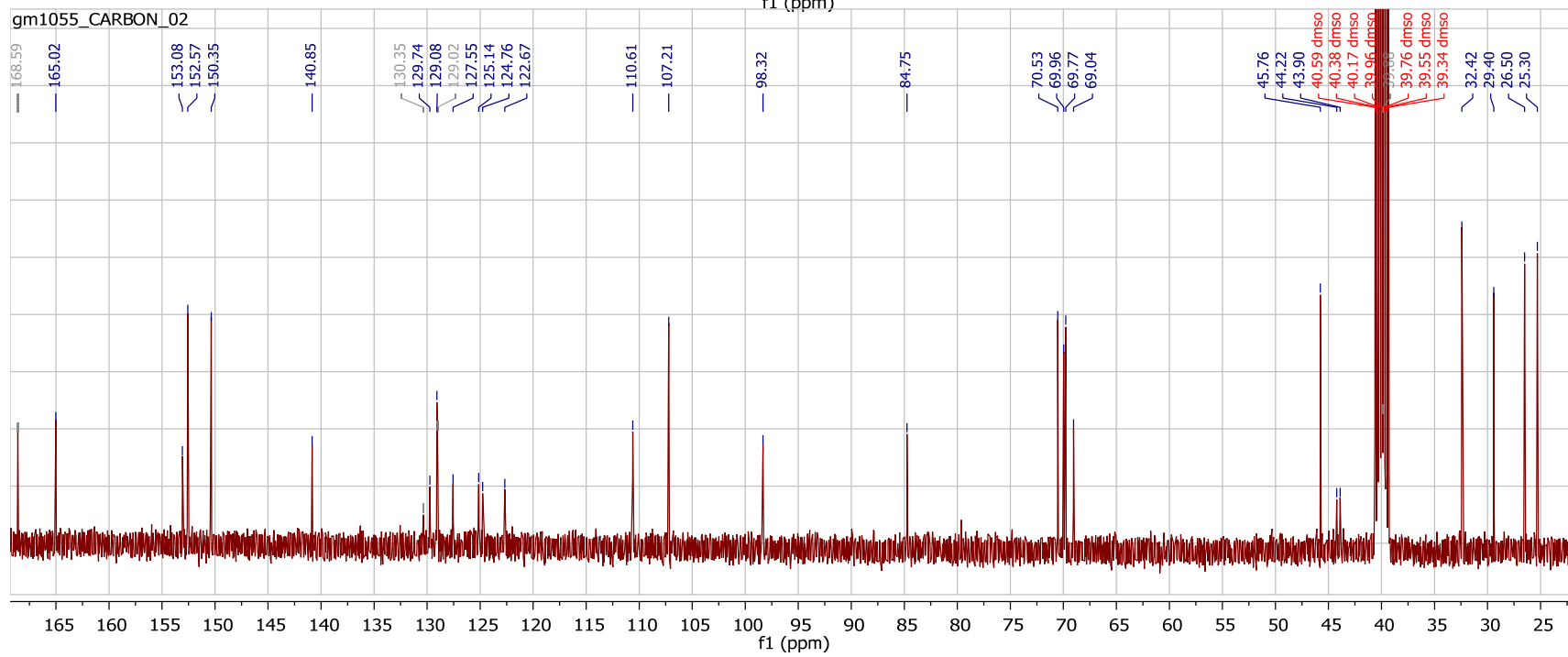
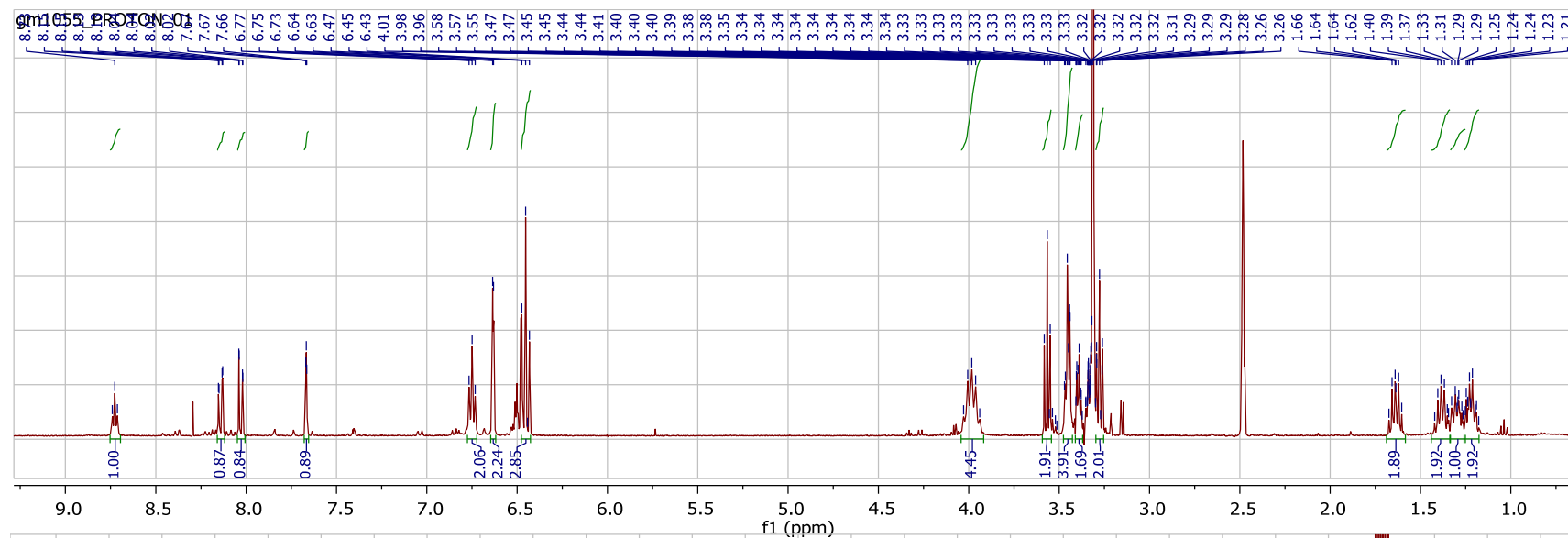

1b-Halo

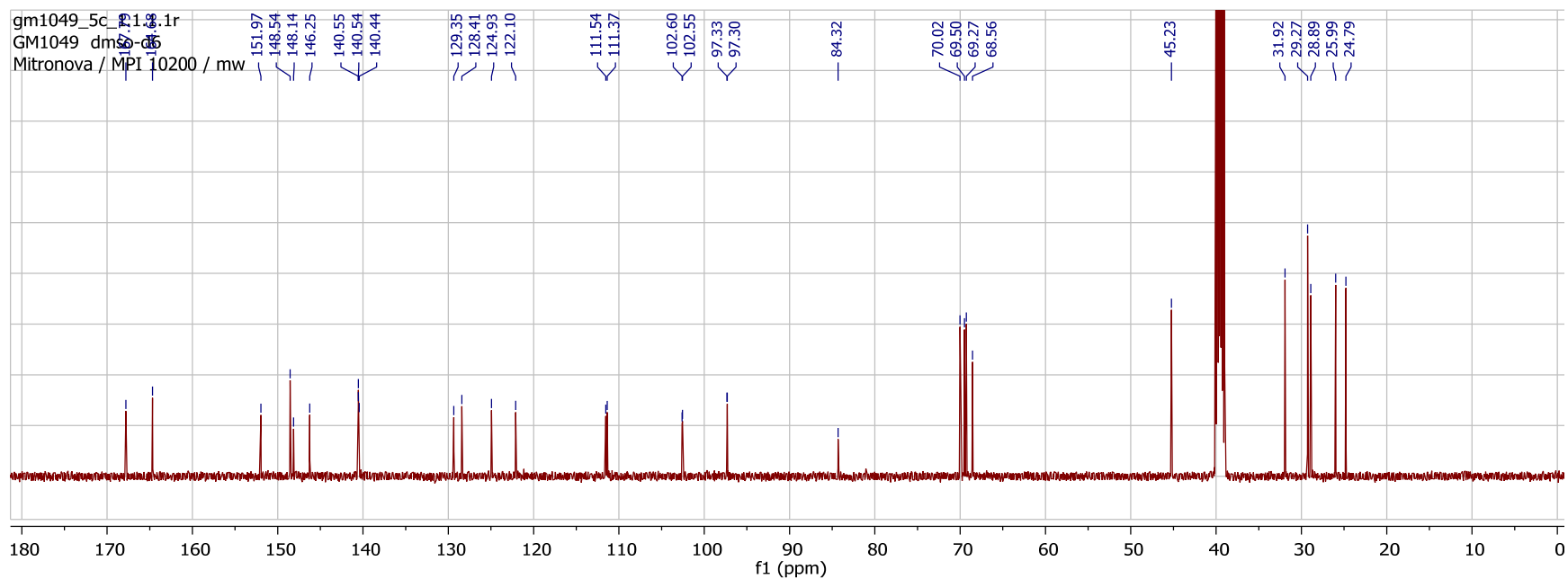
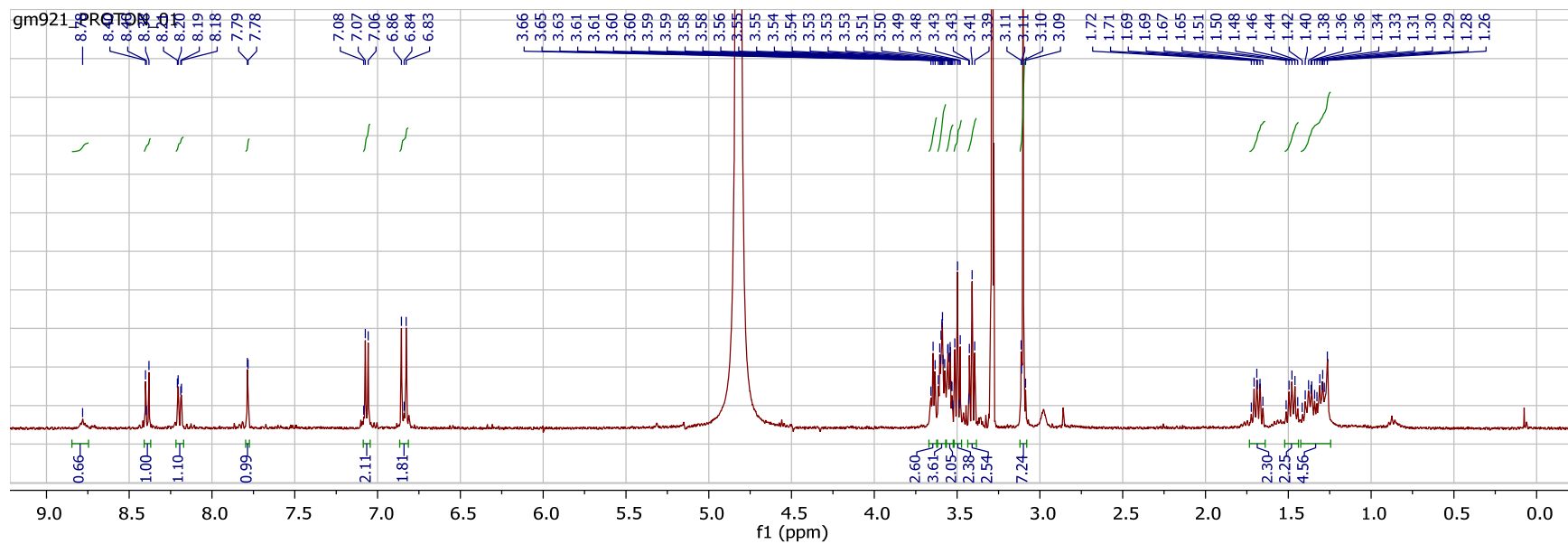

1c (520R)

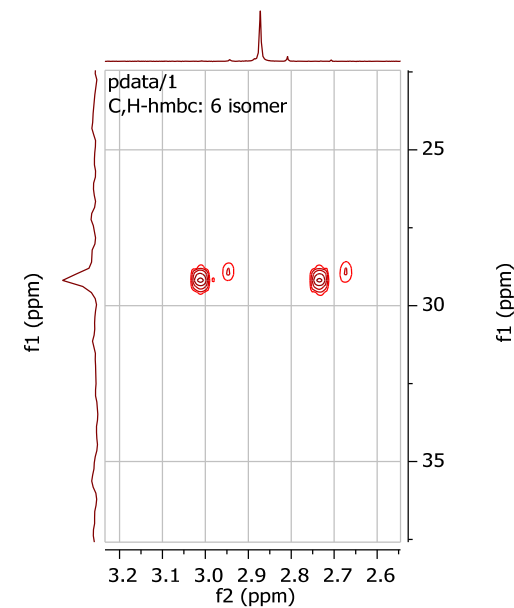
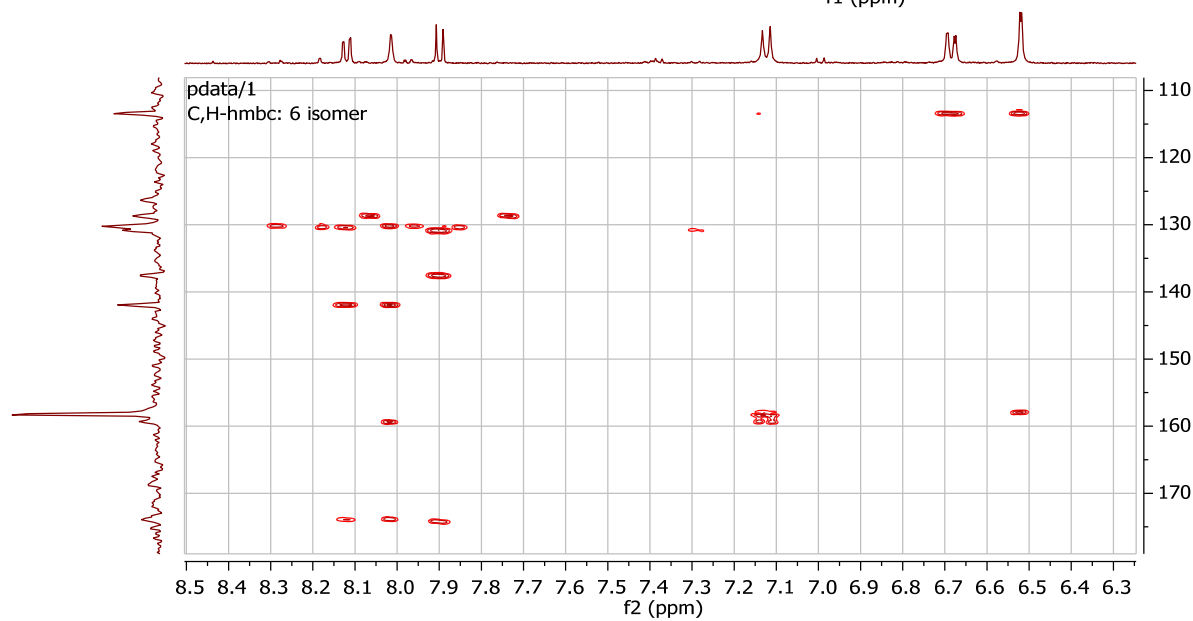
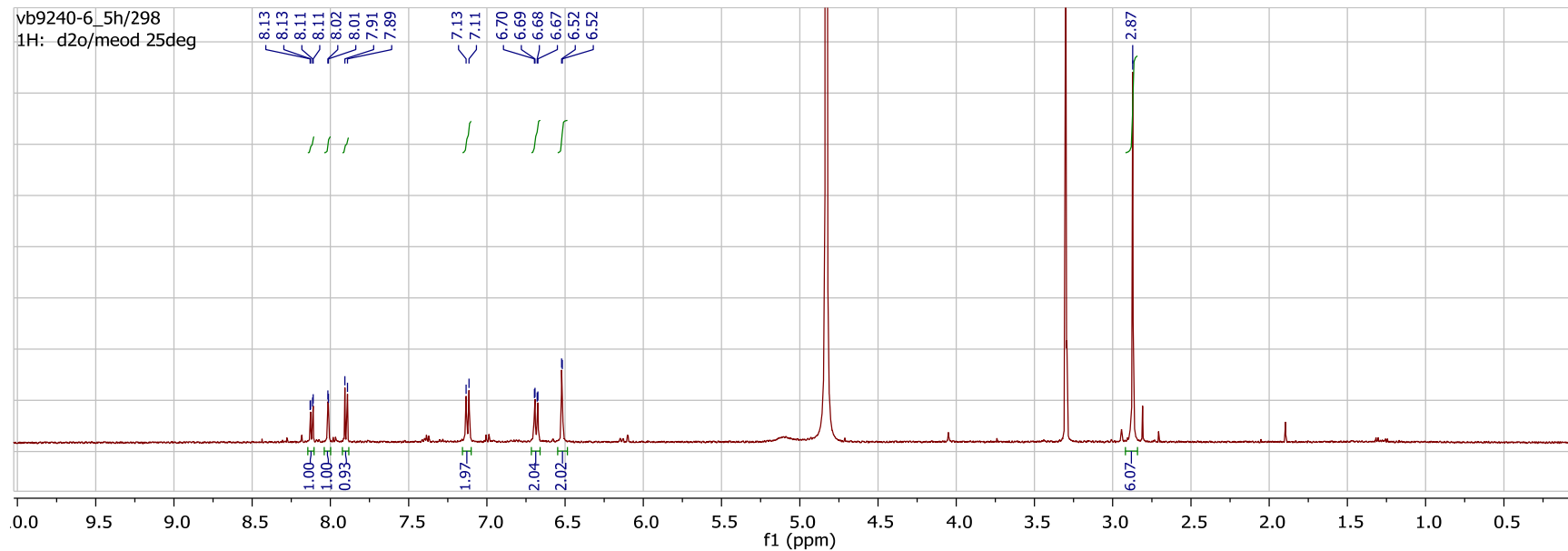

1d-Halo

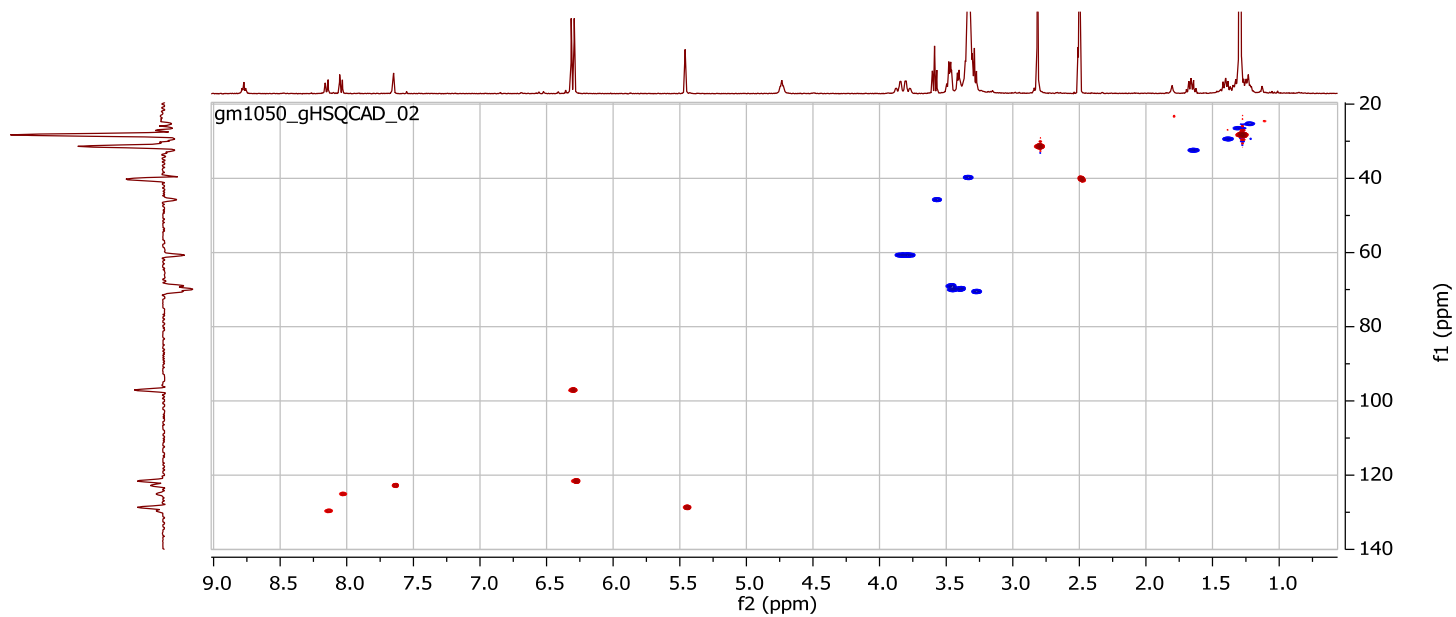
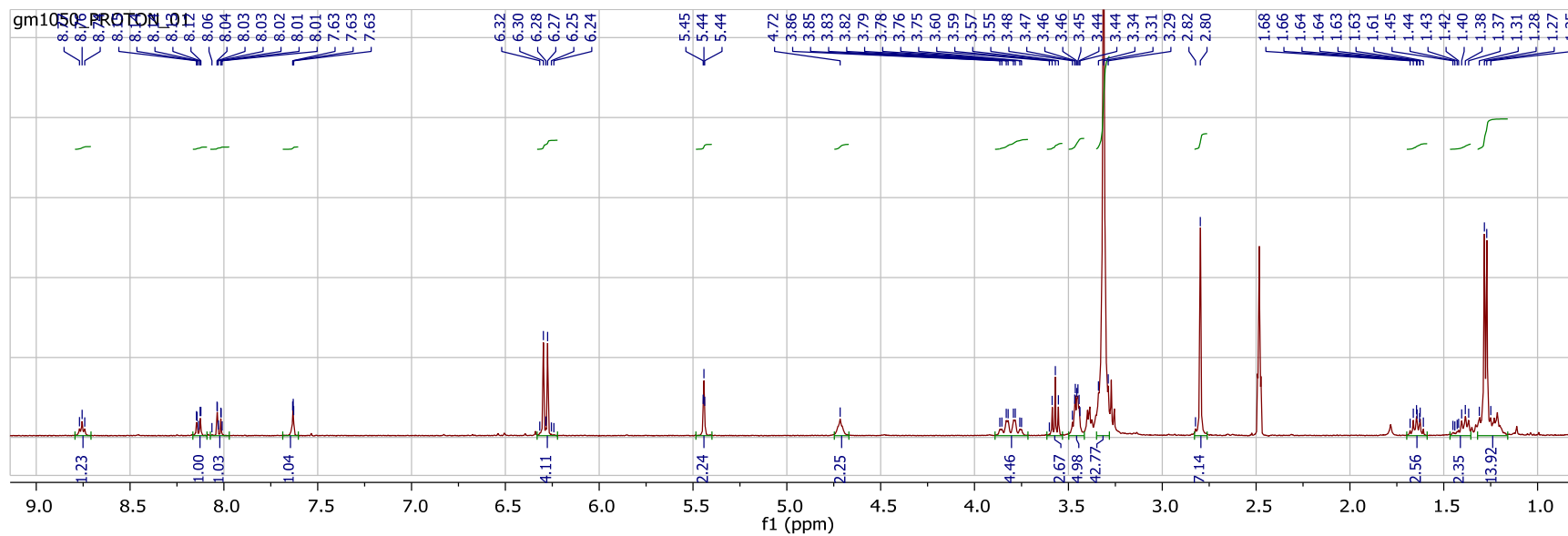

SI-4

ab201-3a_PROTON_01

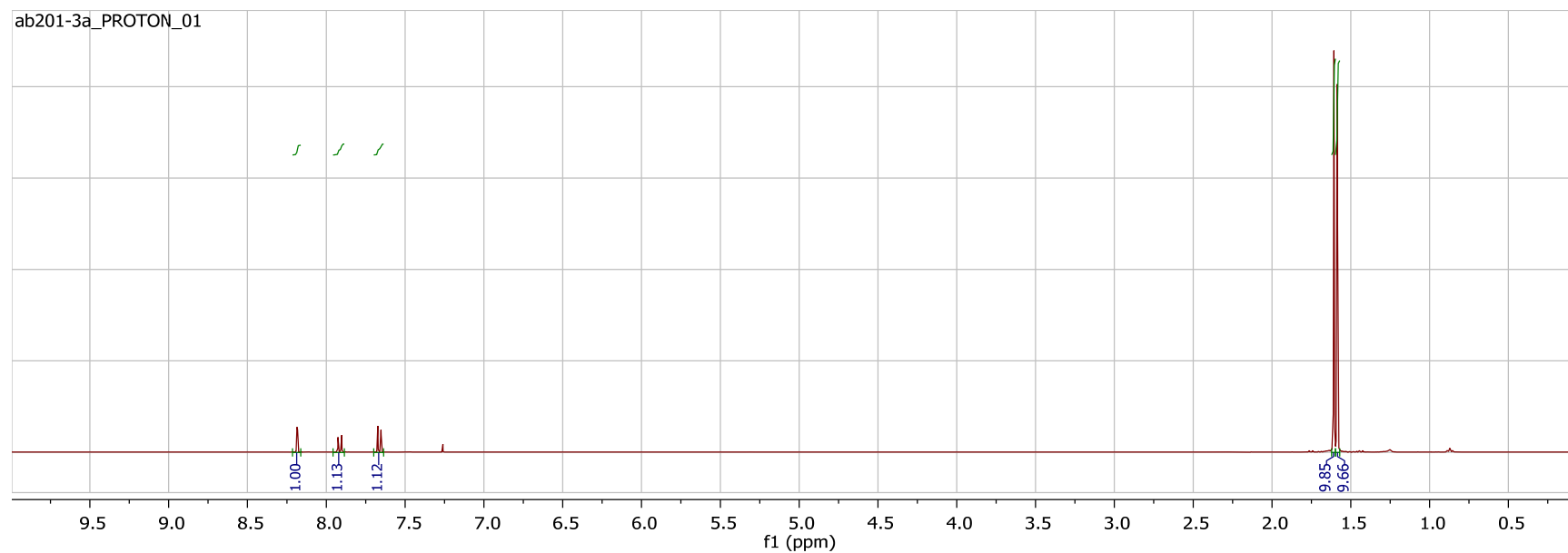

ab201-3a_CARBON_01

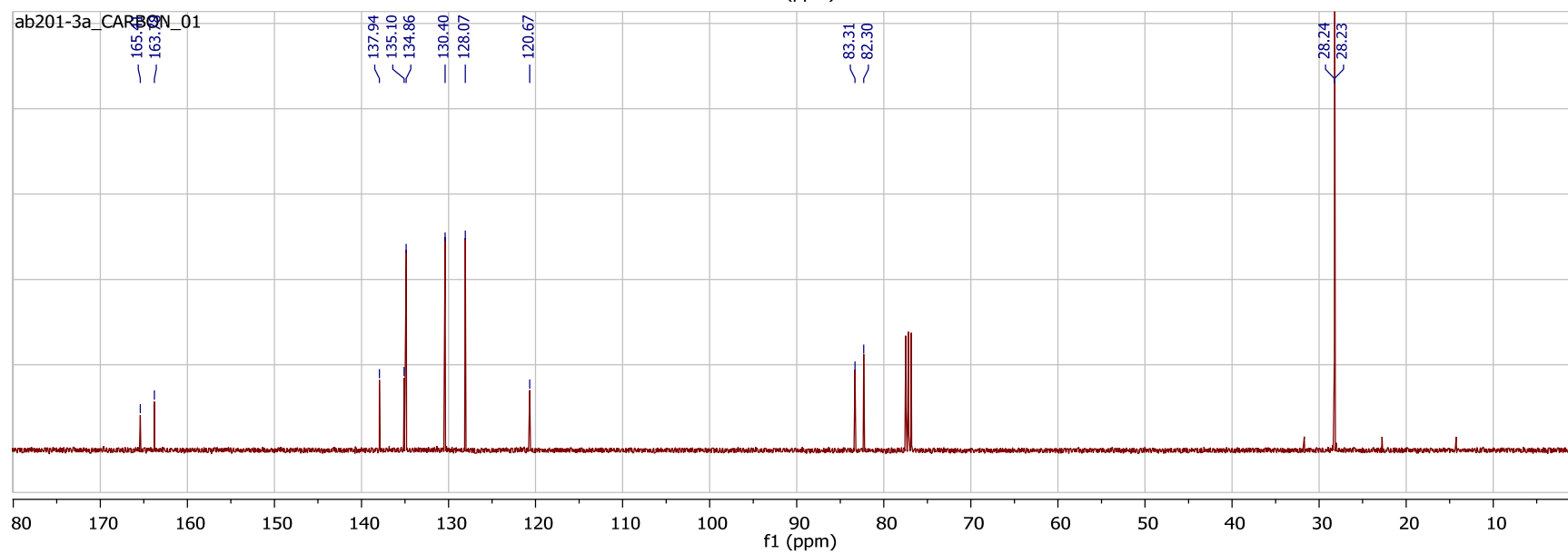

SI-6

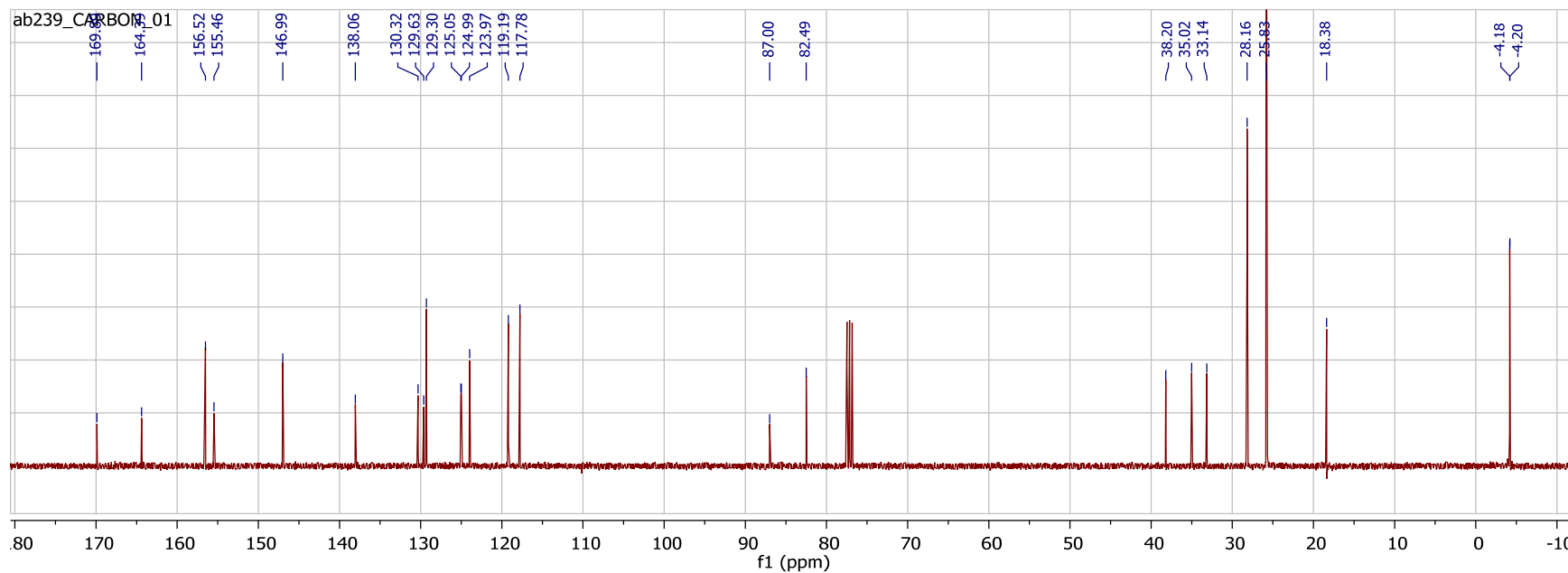
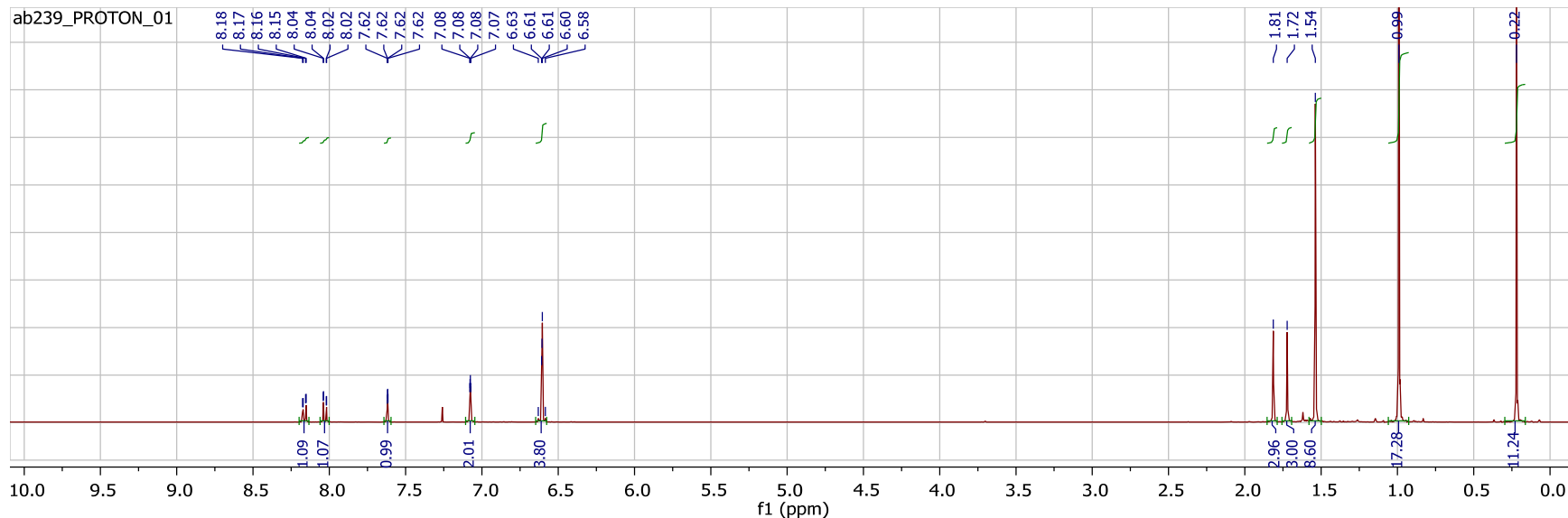

SI-7

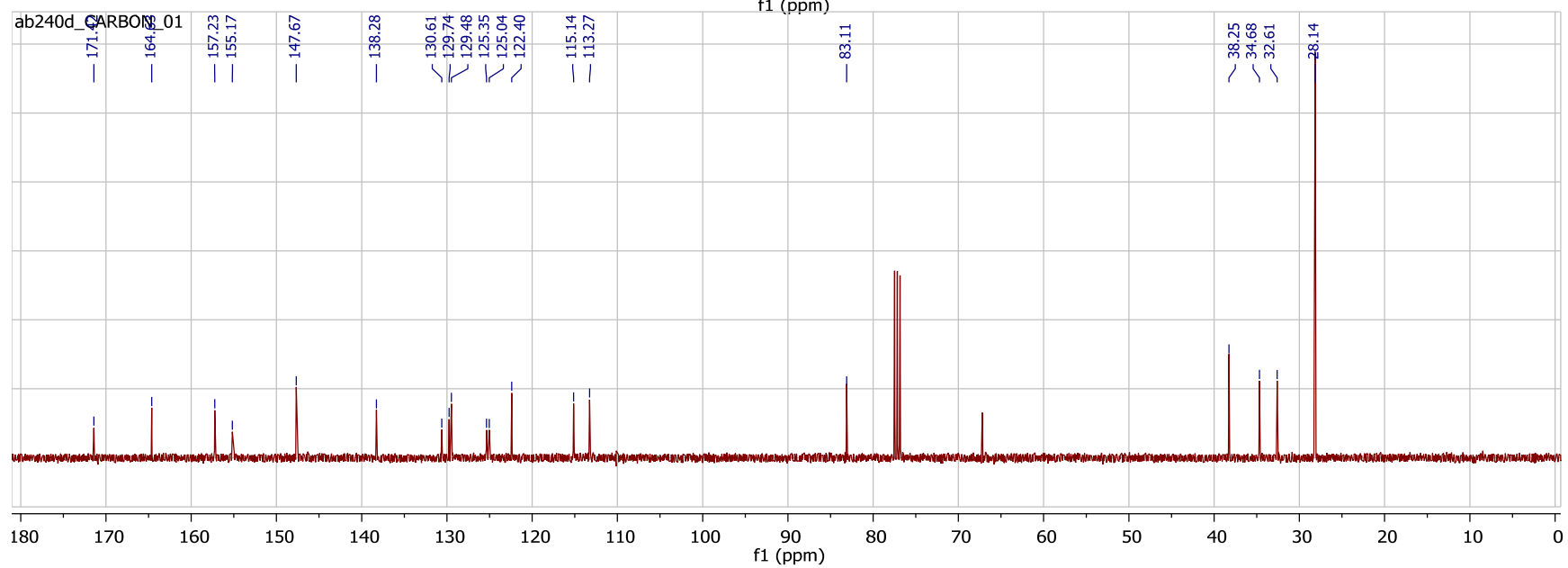
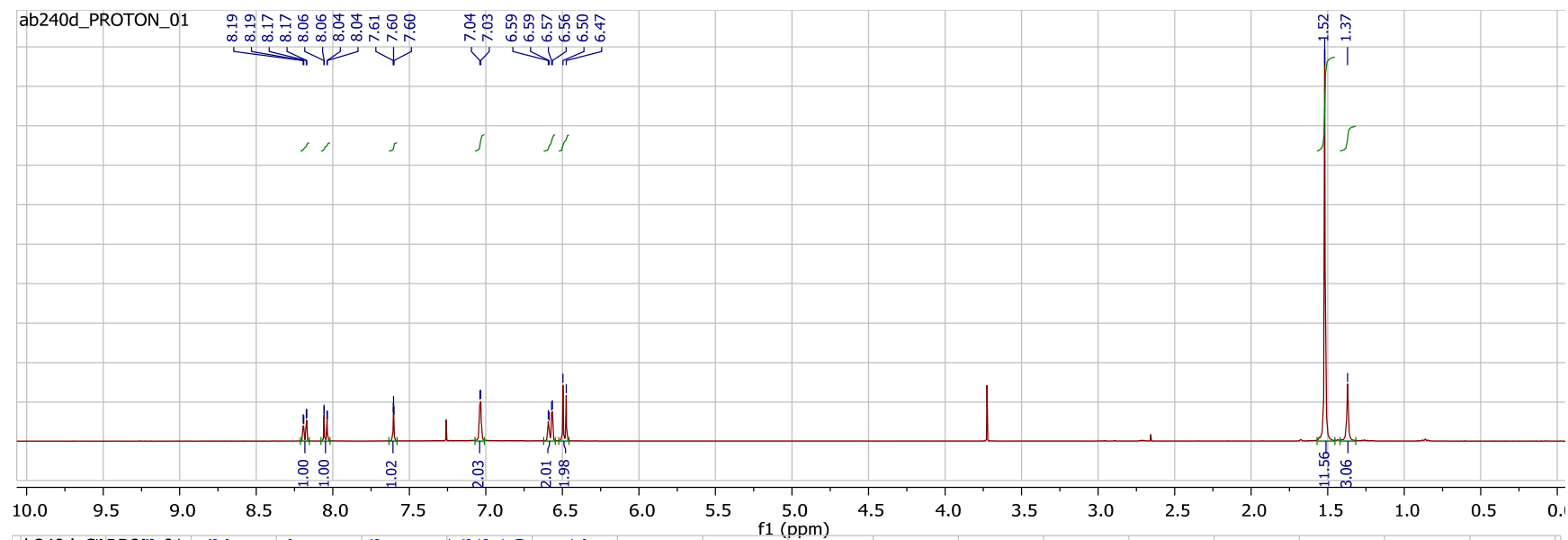

SI-8

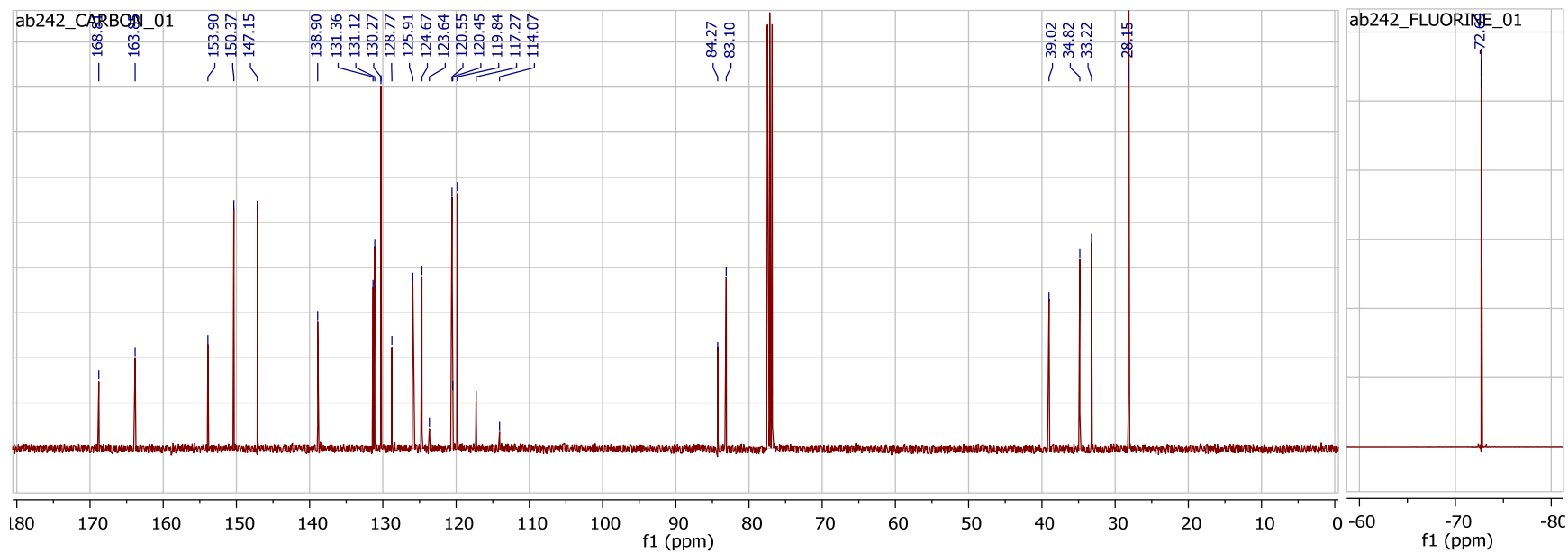
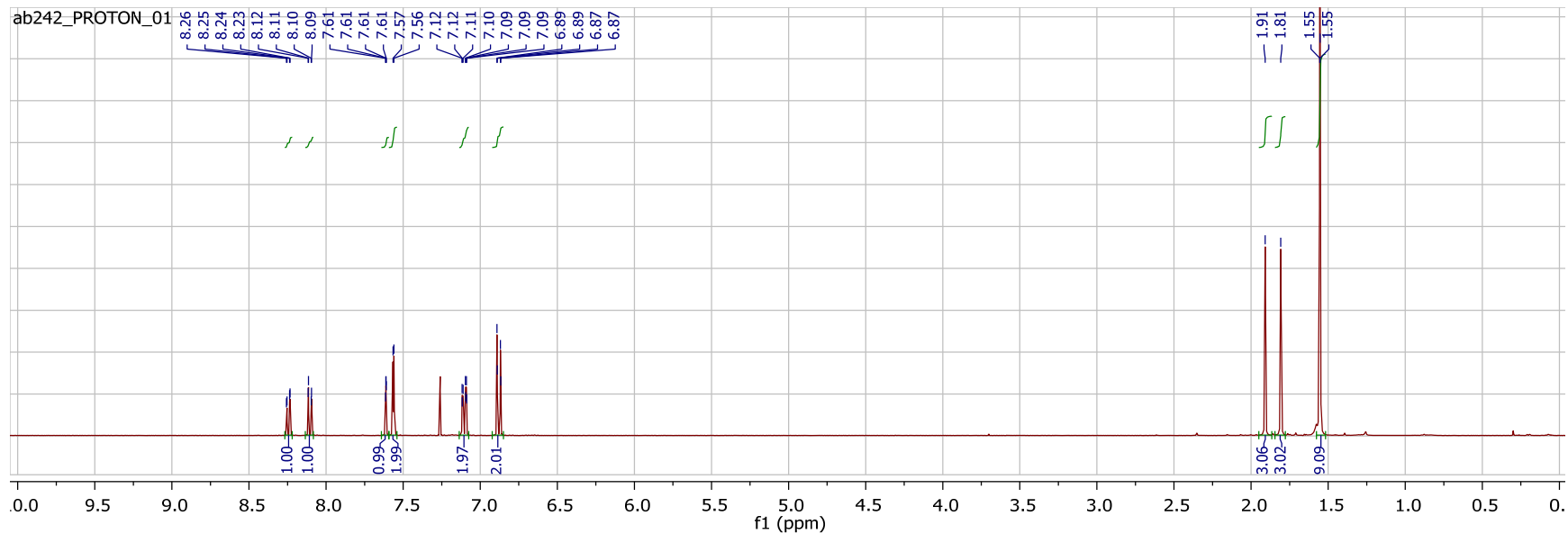

SI-9

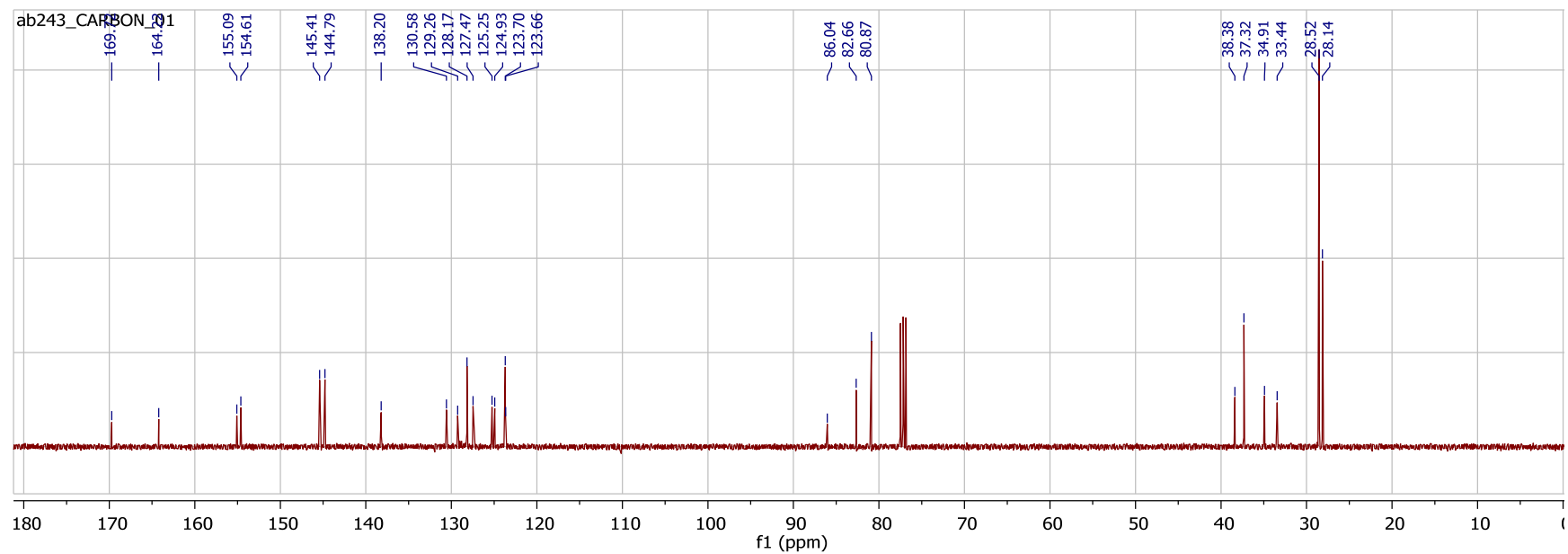
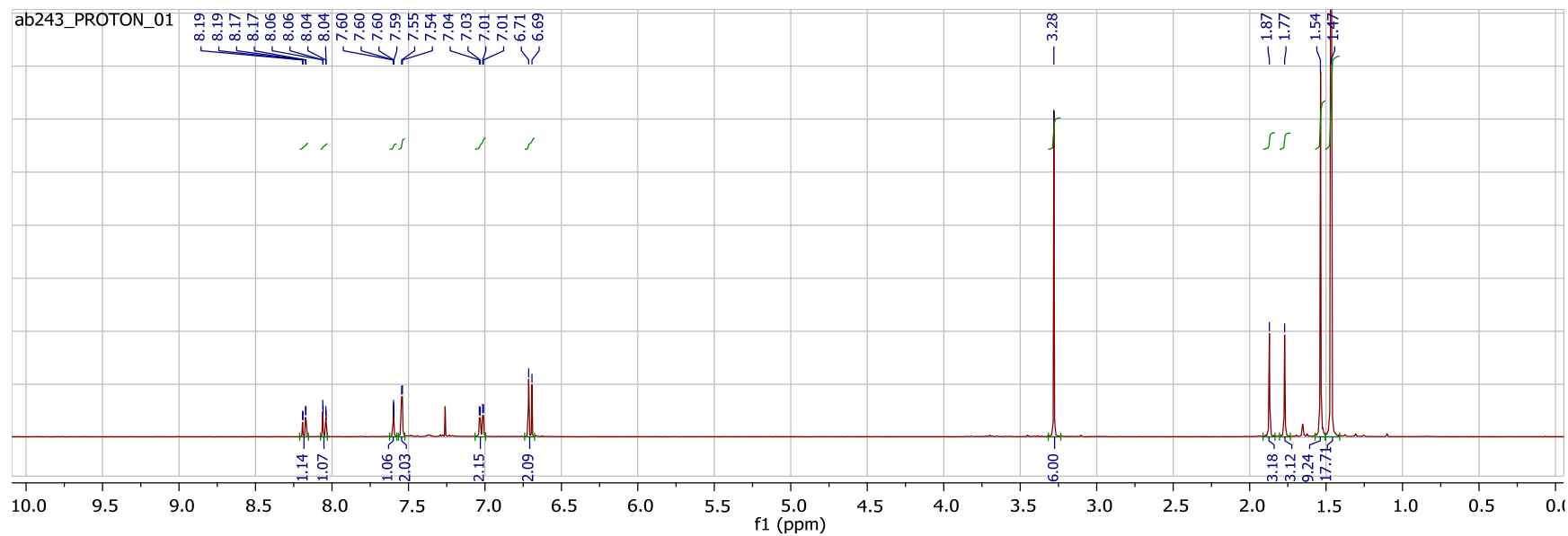

1e (580CP)

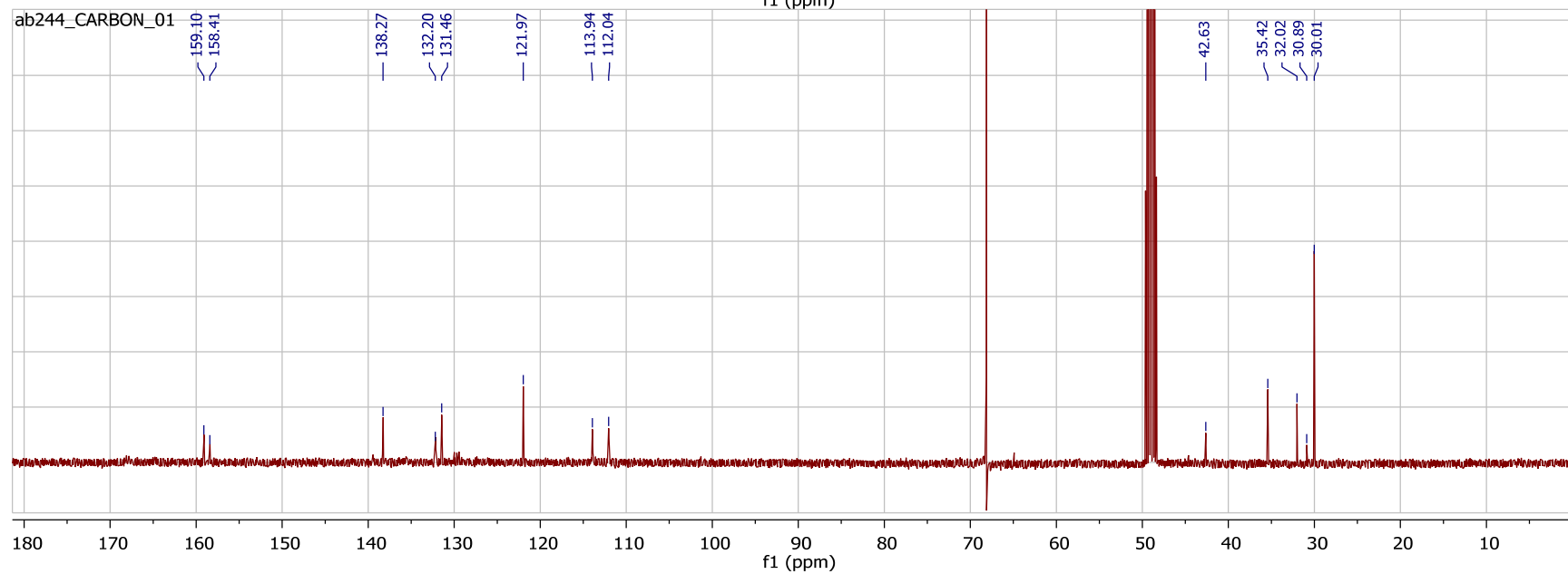
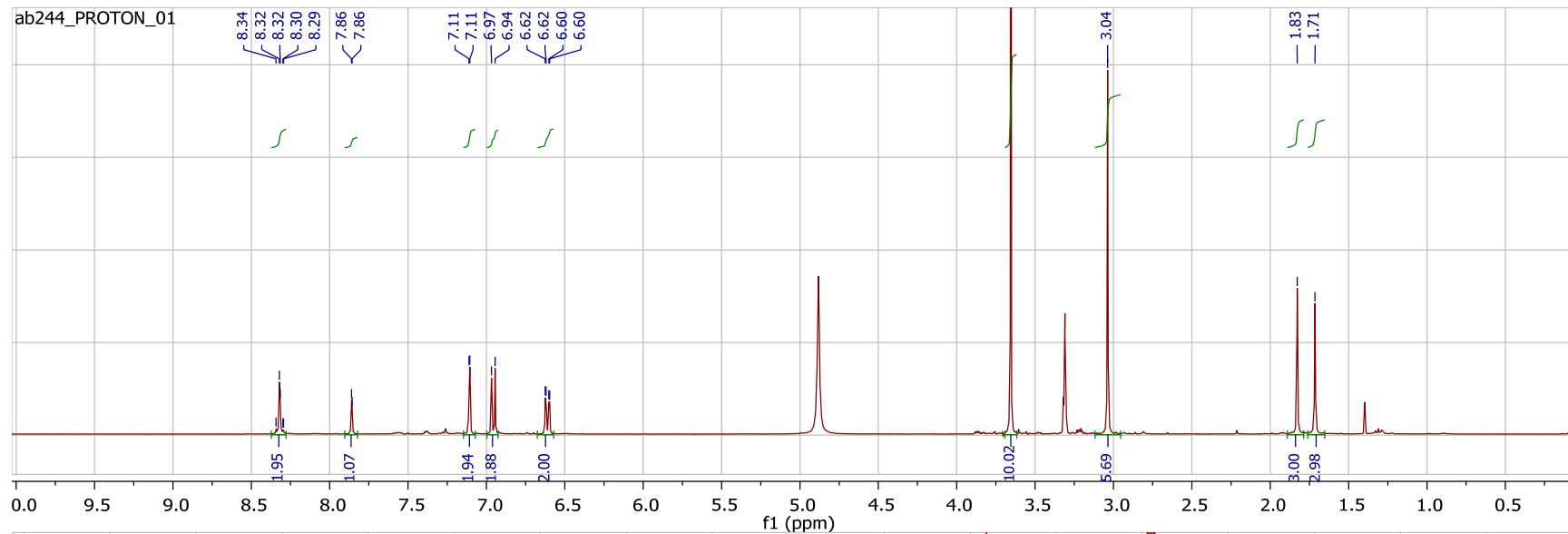

1e-Halo

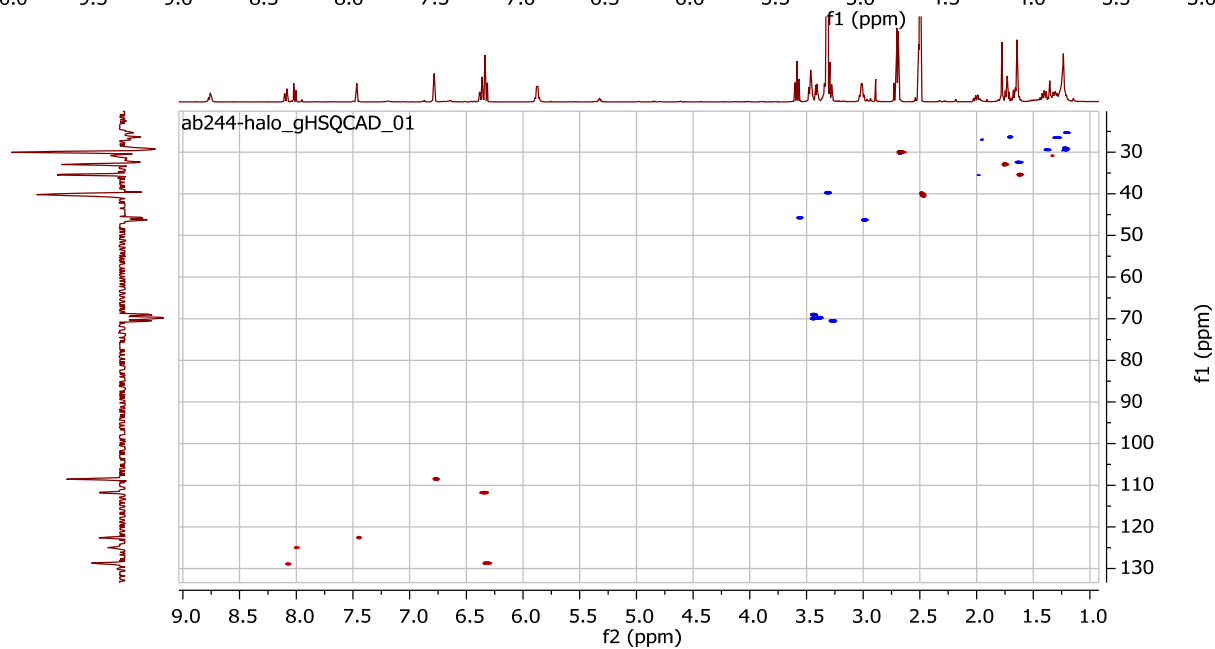
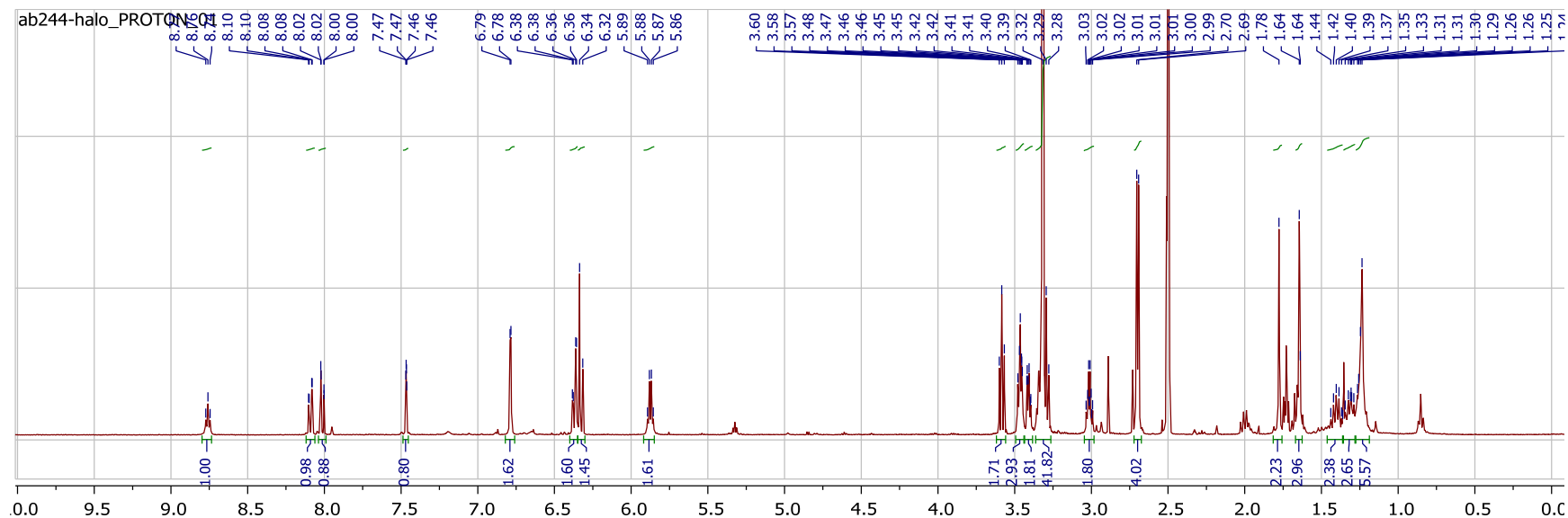

SI-10

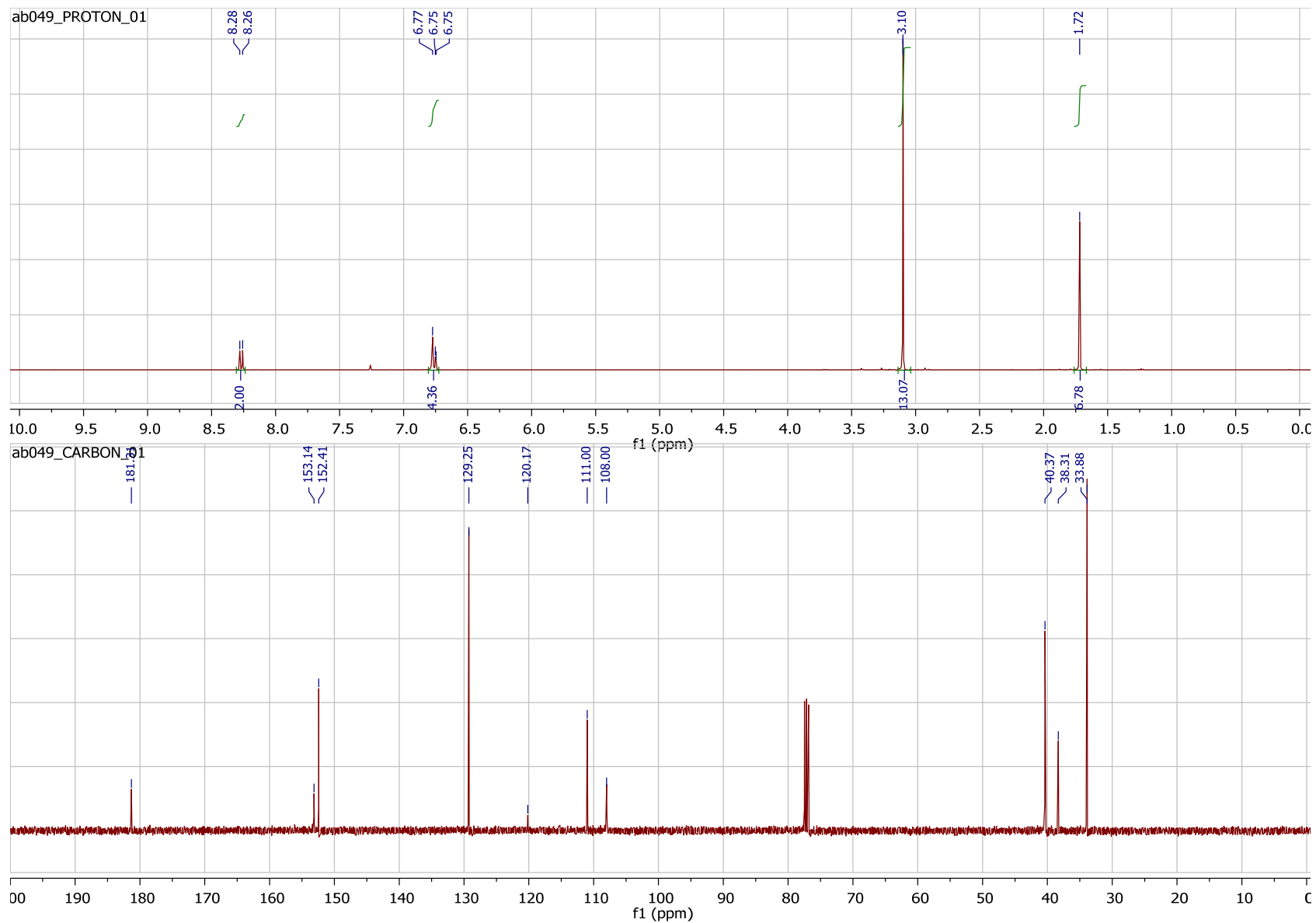

1f (610CP)

ab209a_PROTON_01

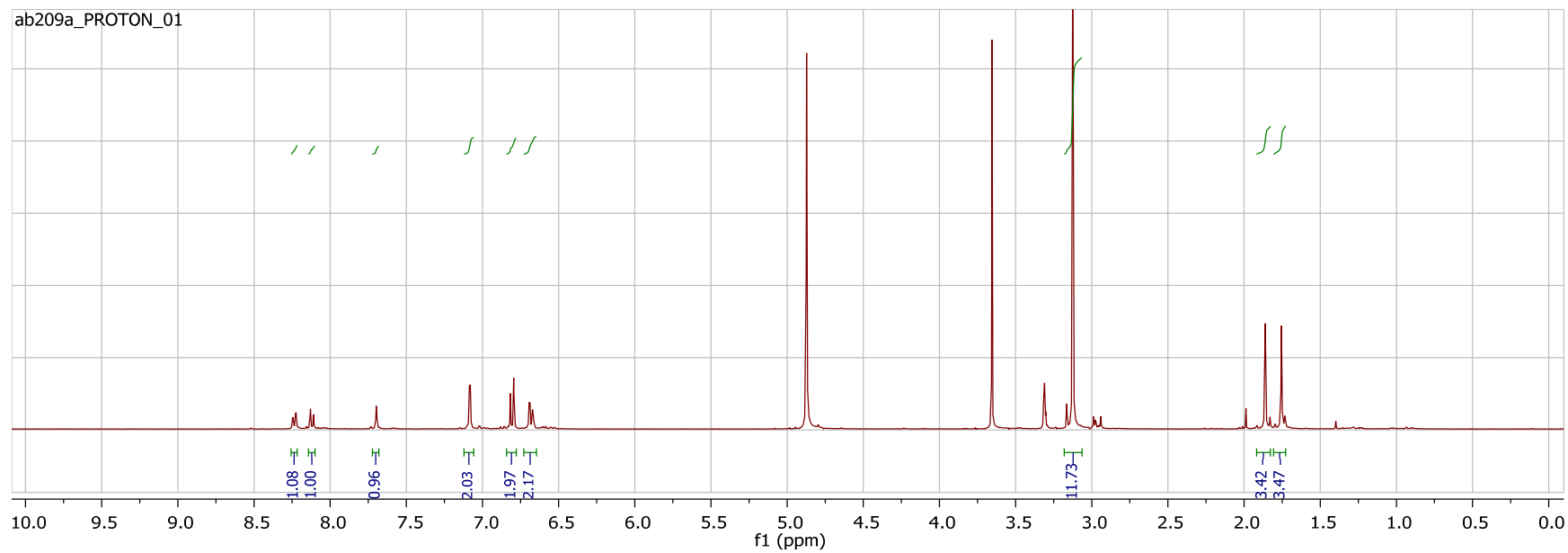

ab209a CARBON_02

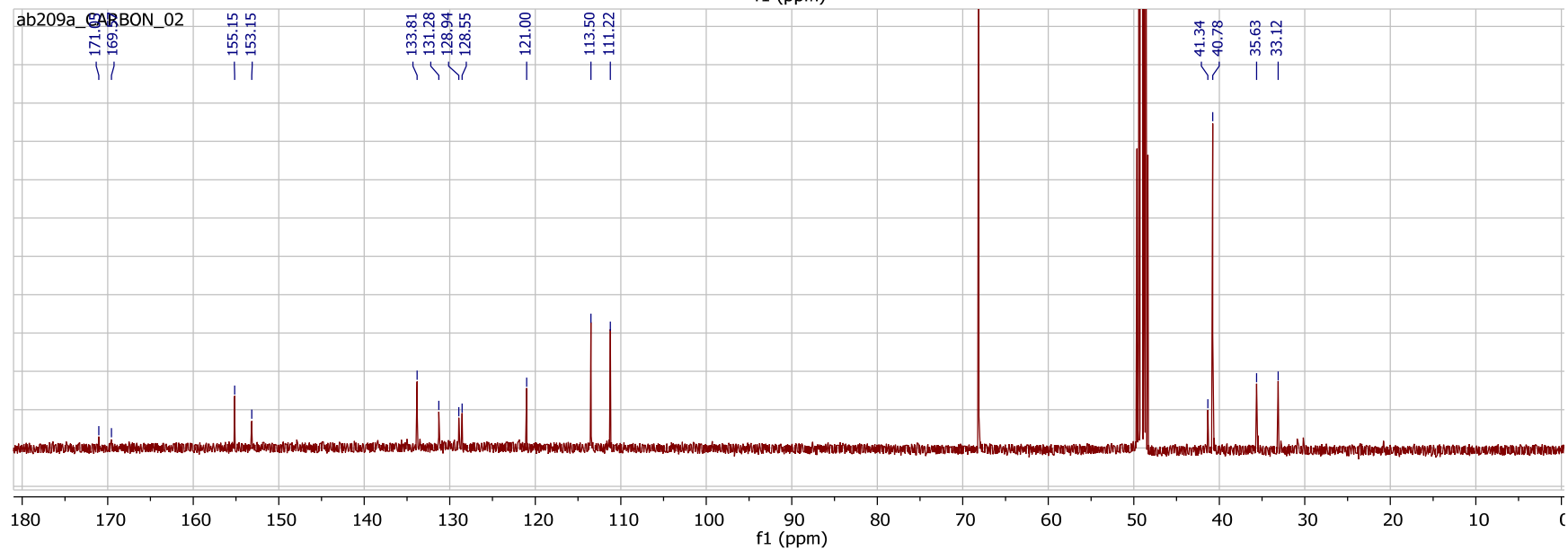

1f-Halo

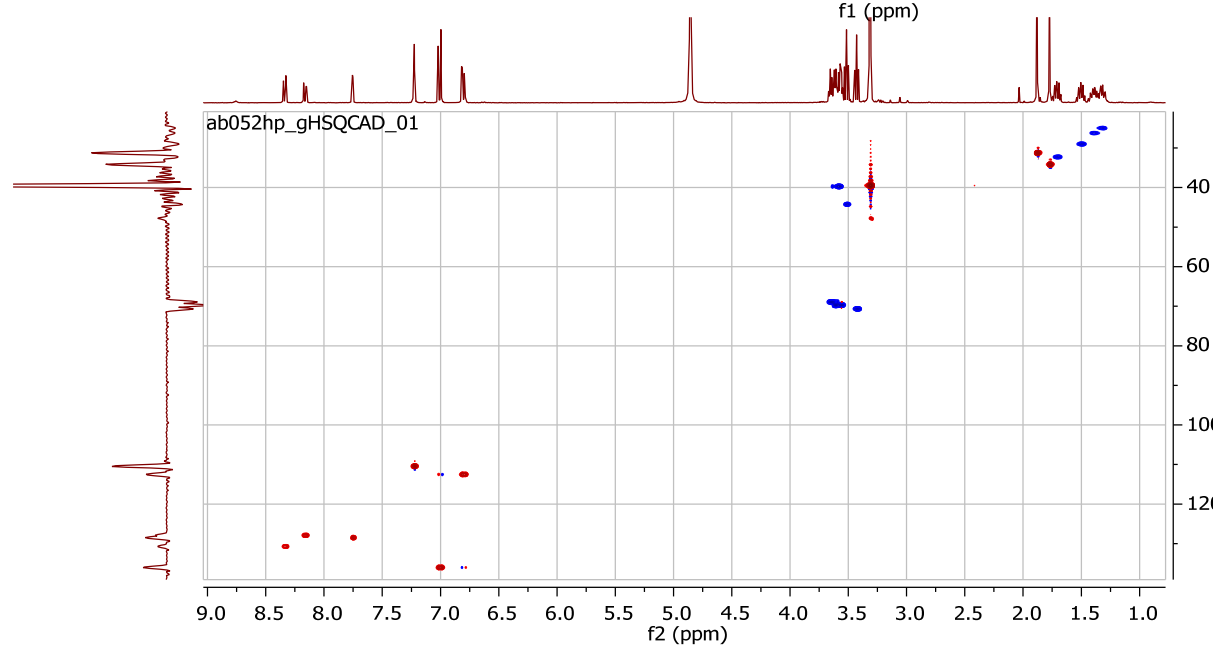
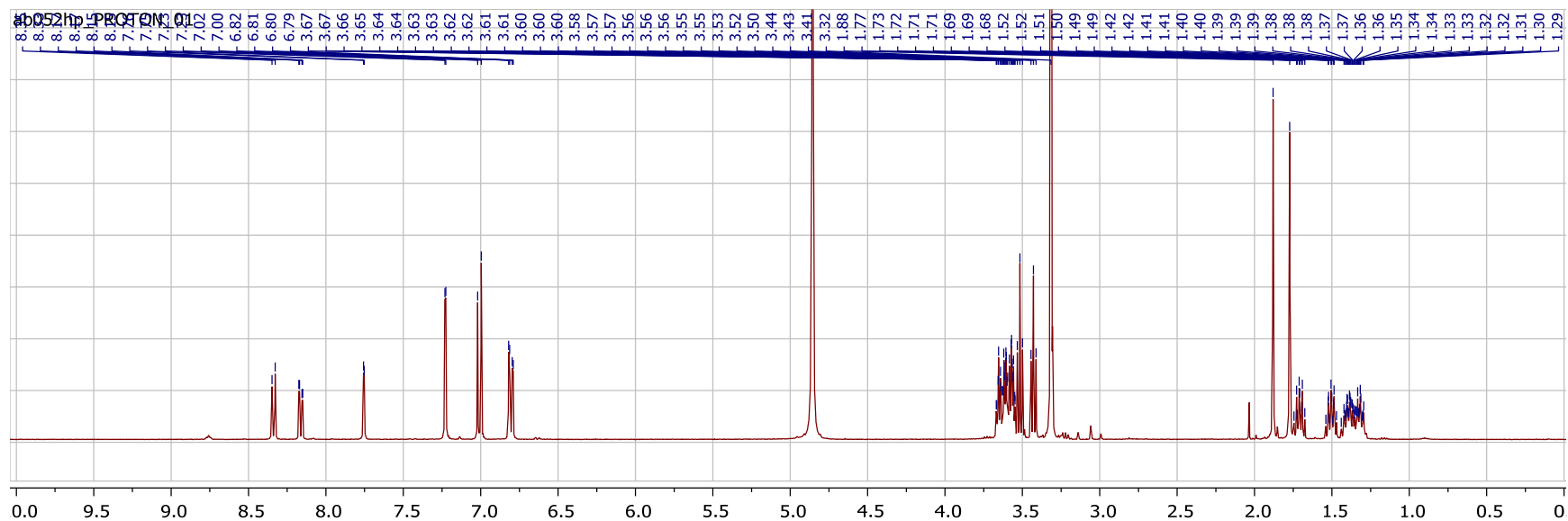

SI-11

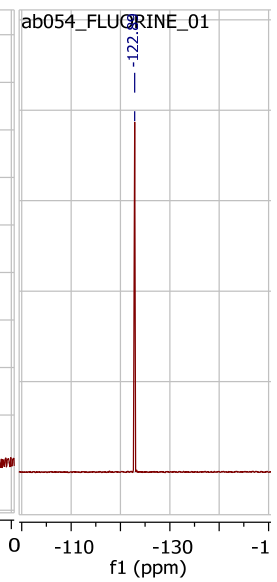
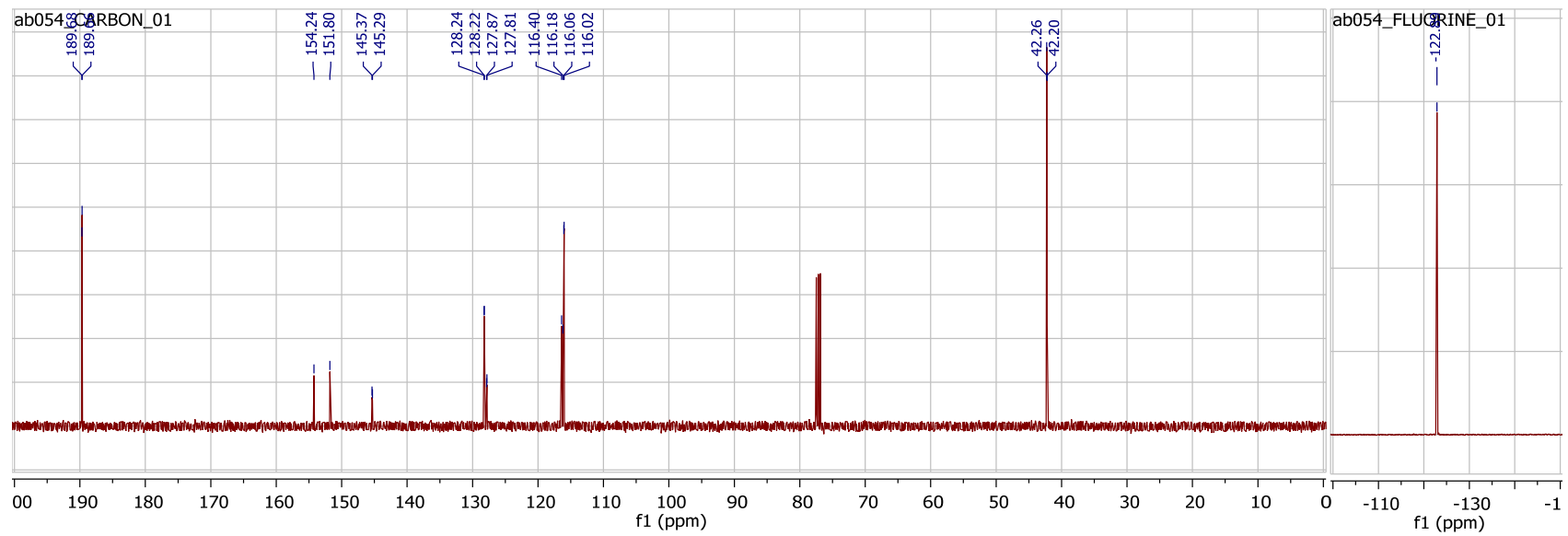
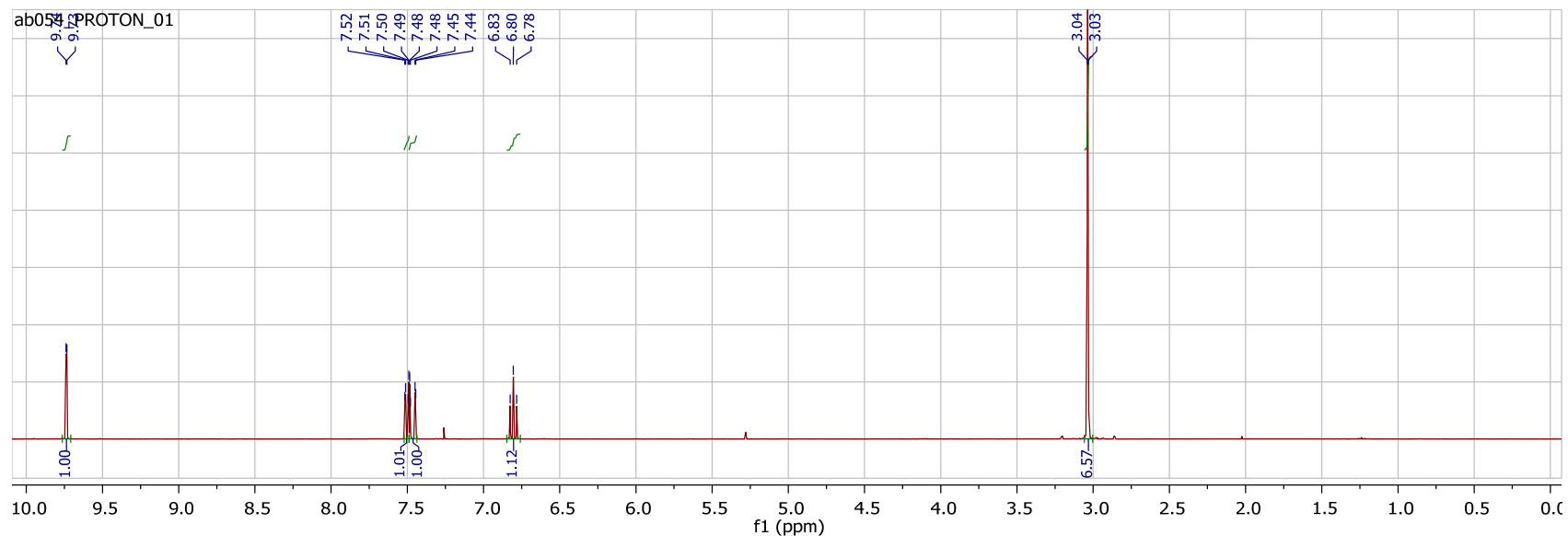

SI-12

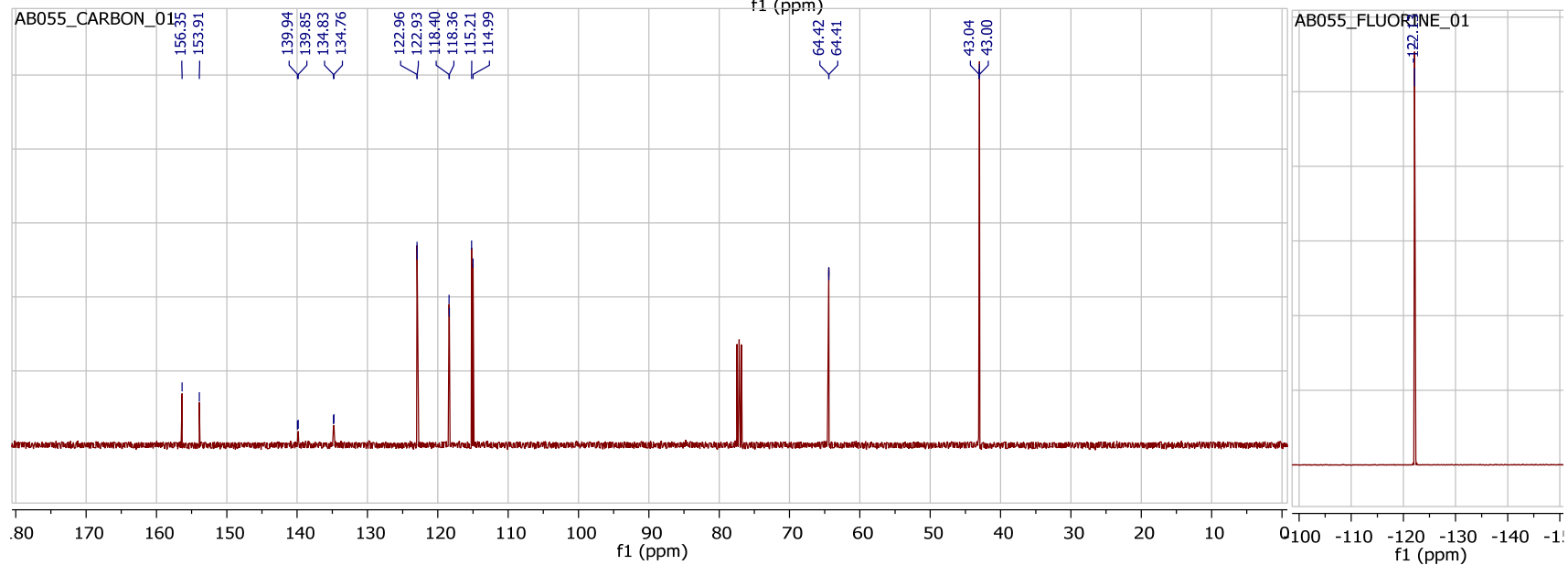
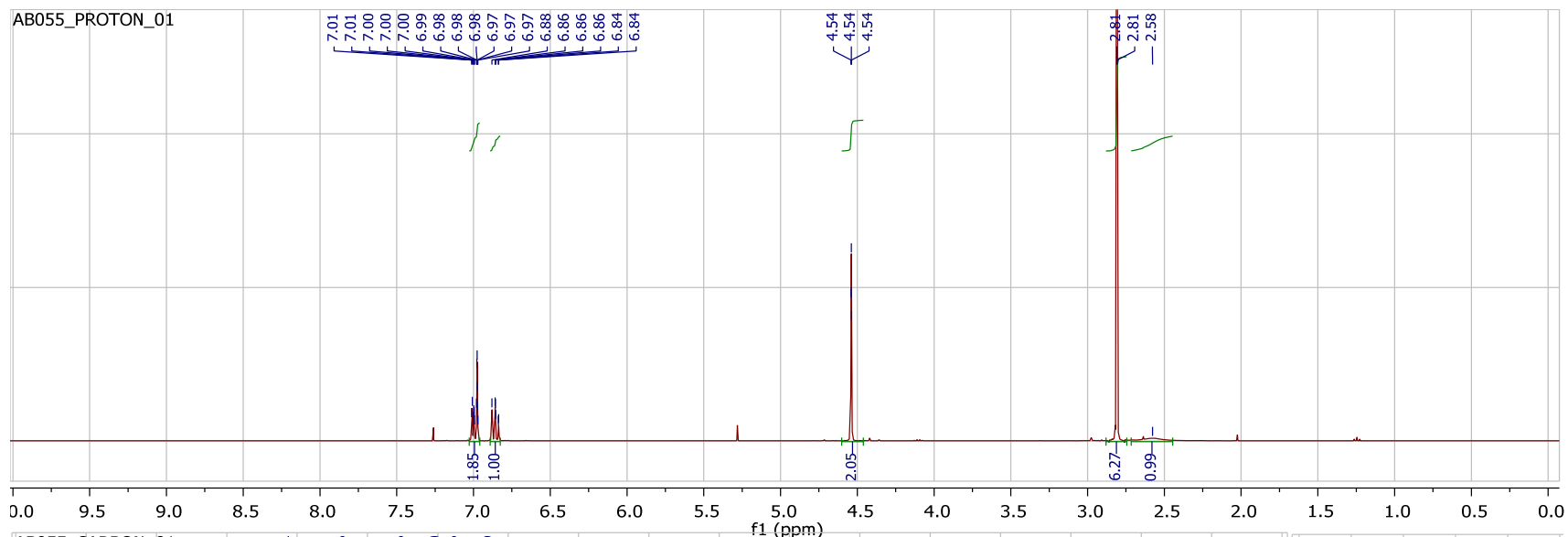

SI-13

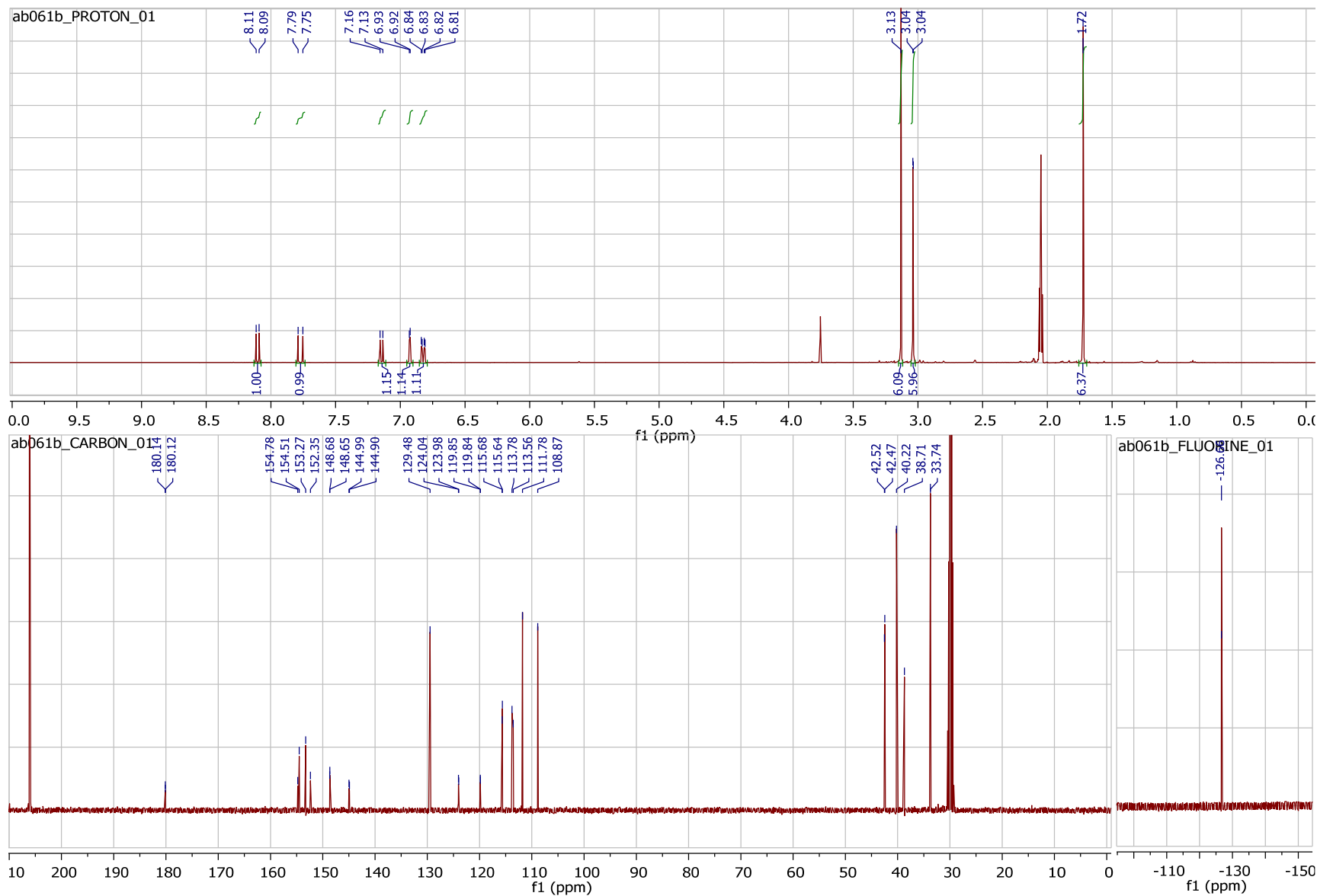

1g (620CP)

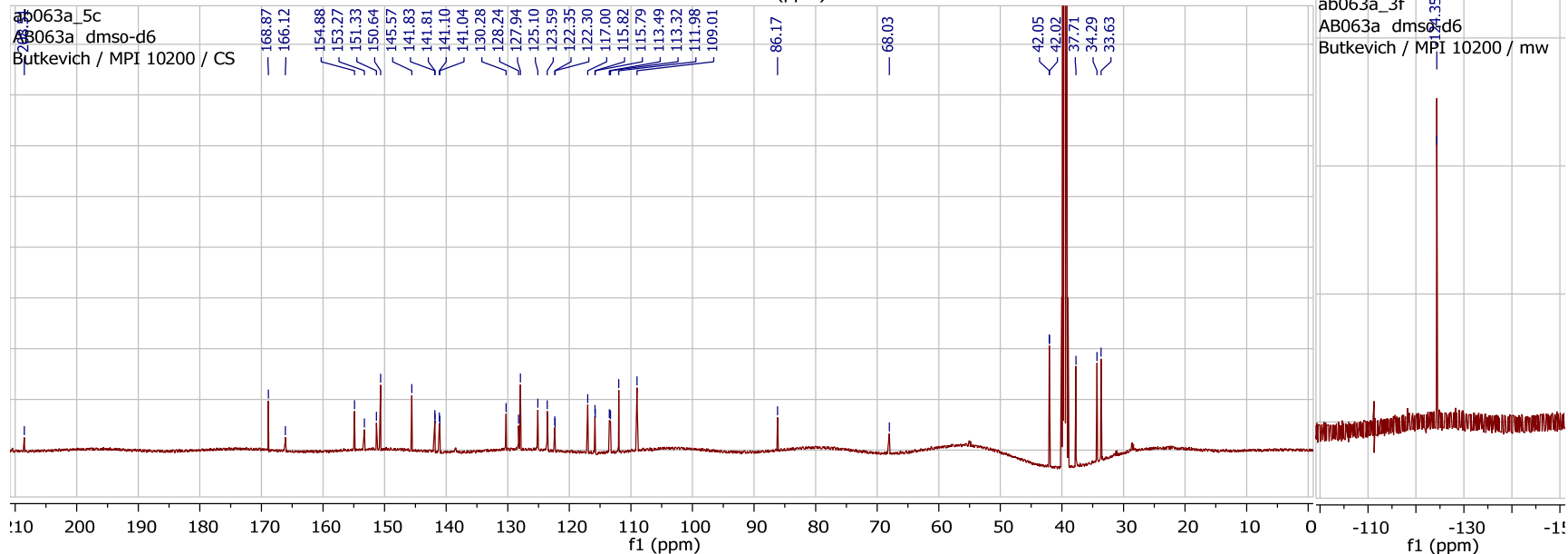
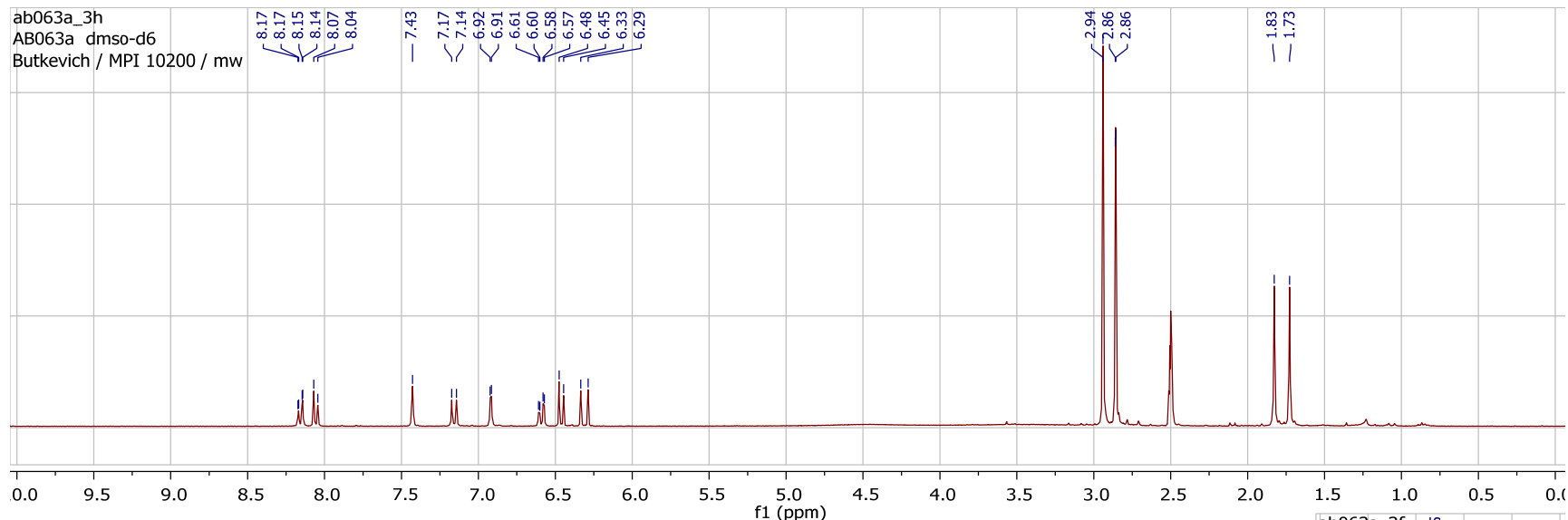

1g-Halo

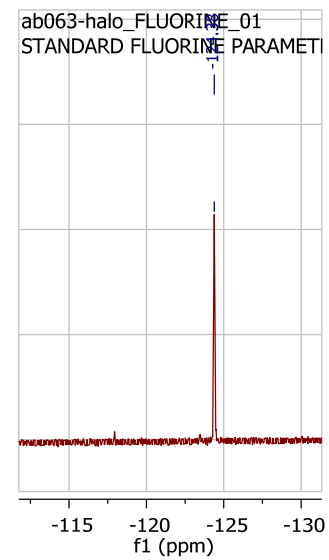
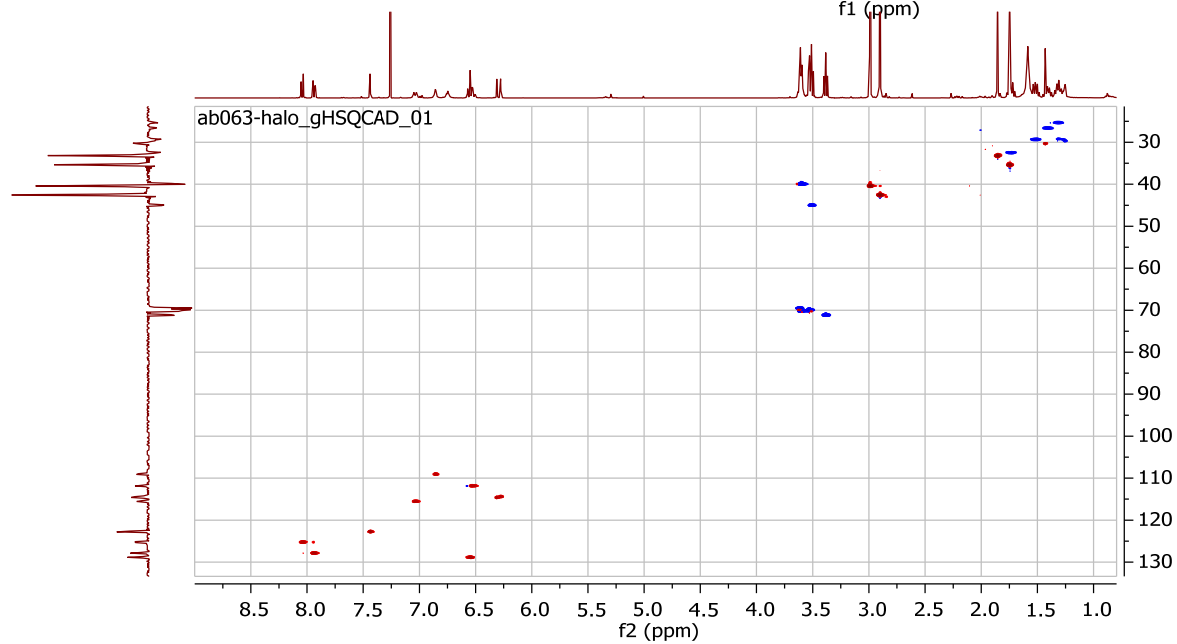
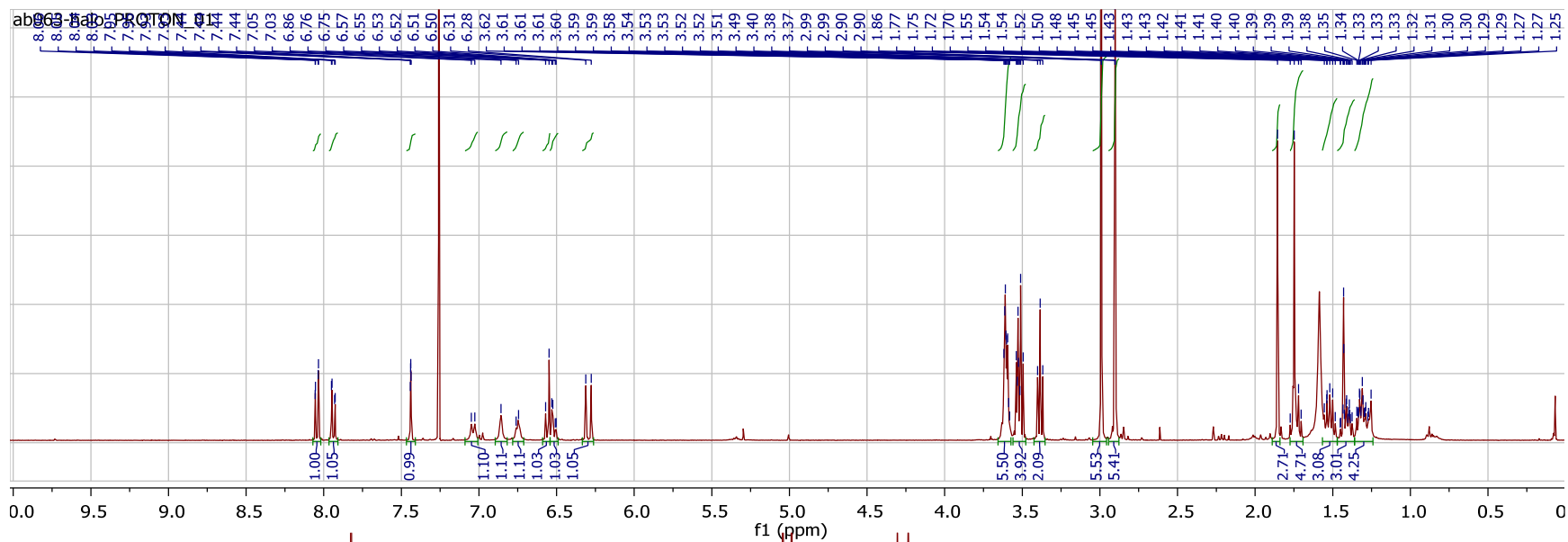

SI-14

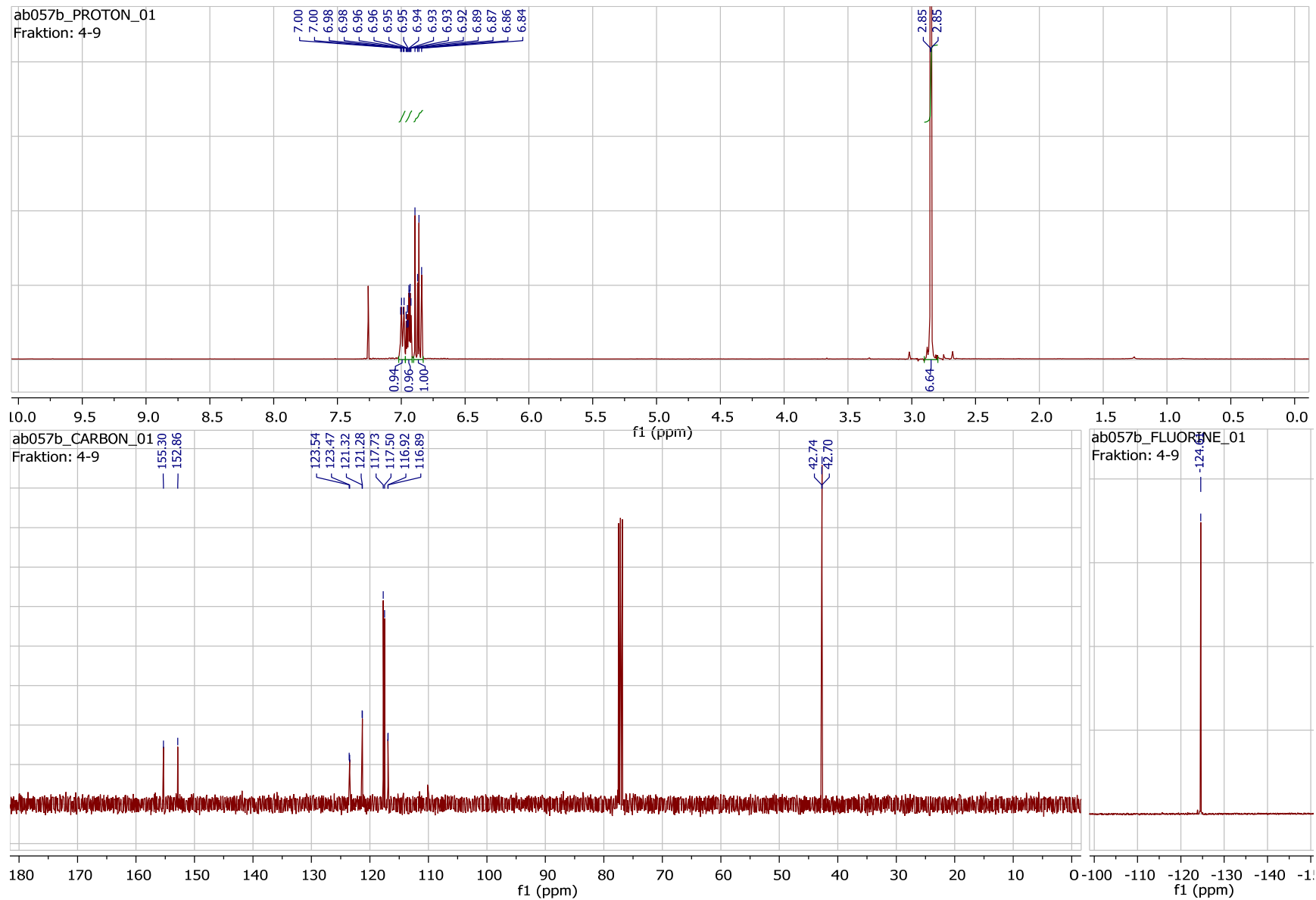

SI-15

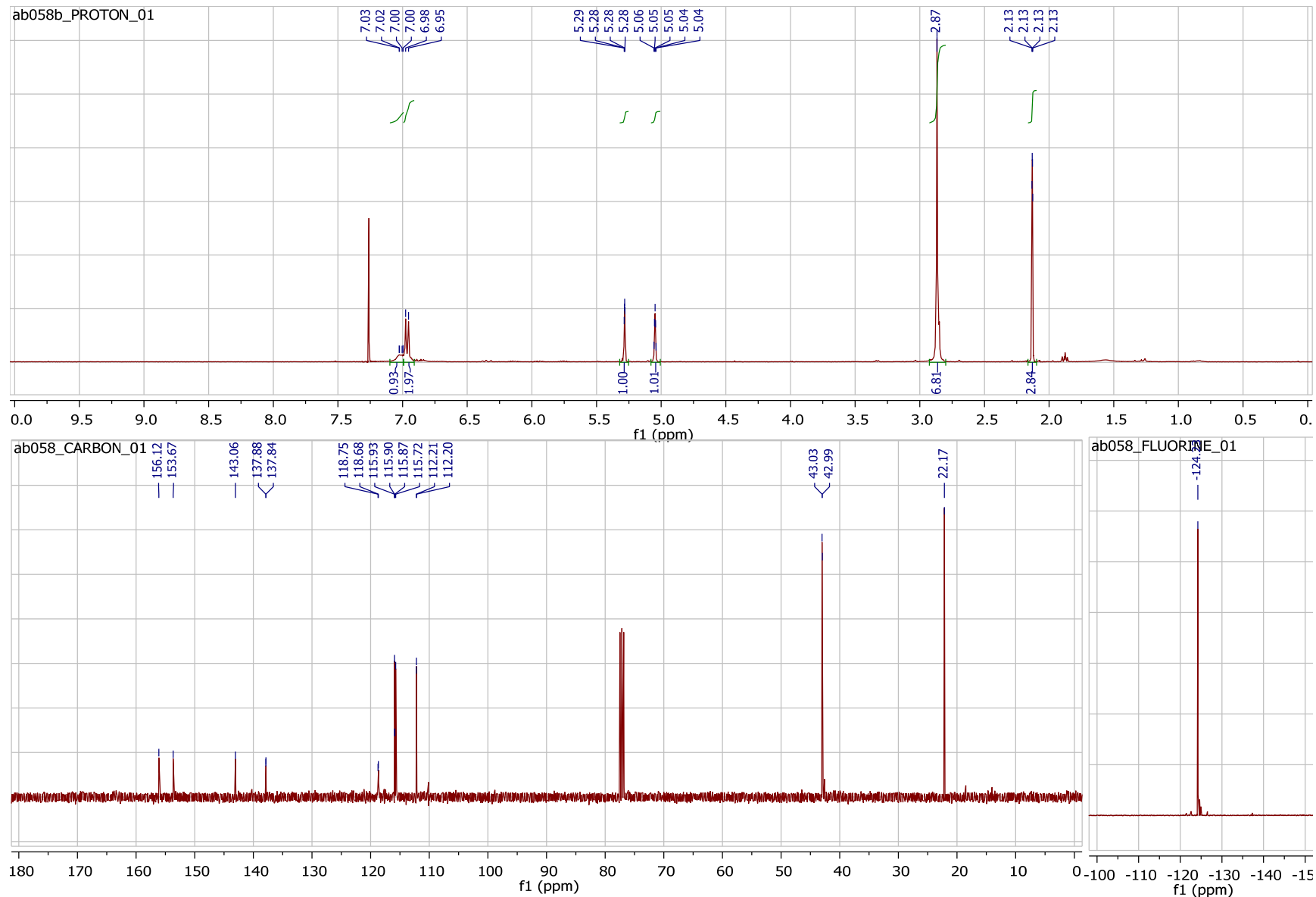

SI-16

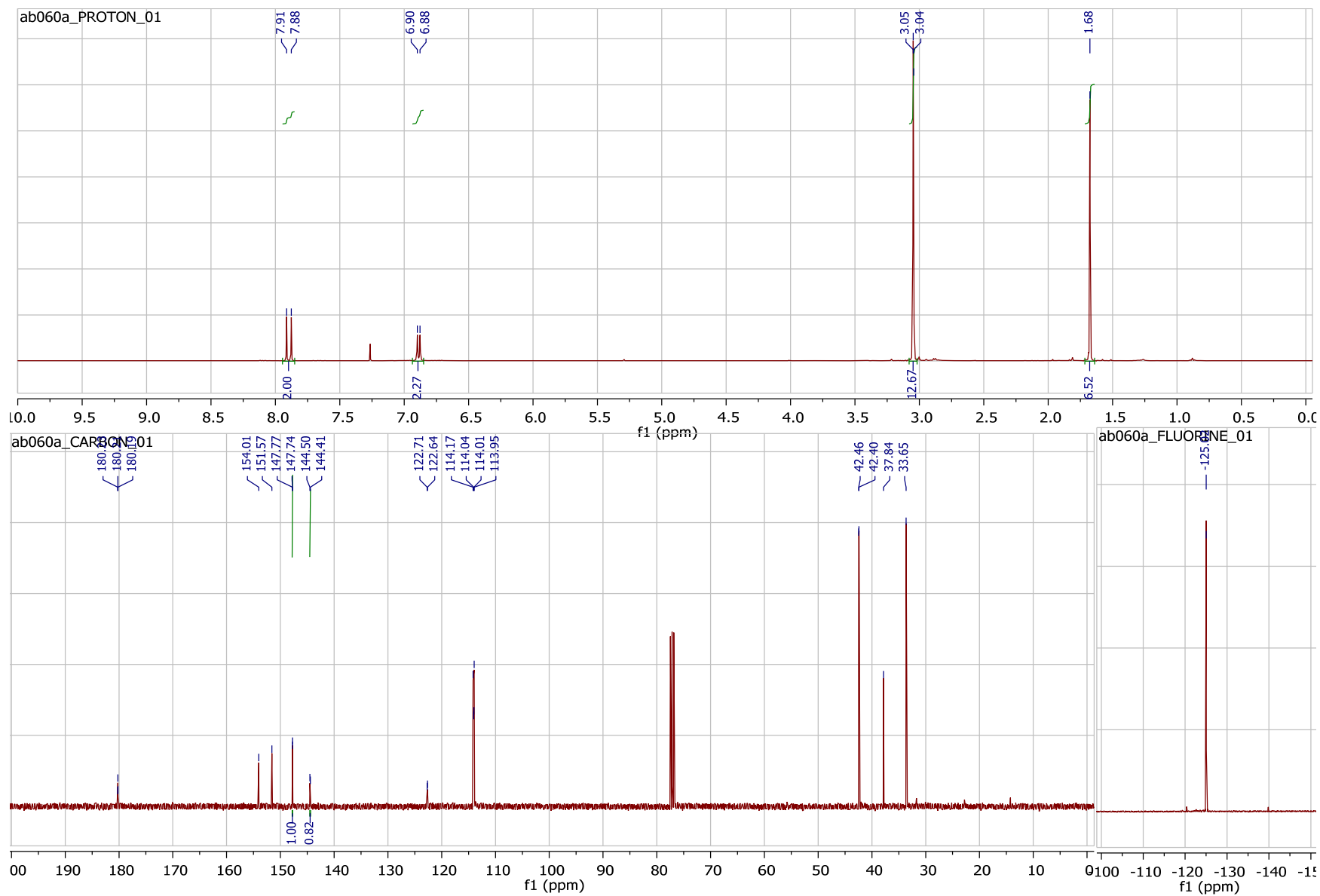

1h (630CP)

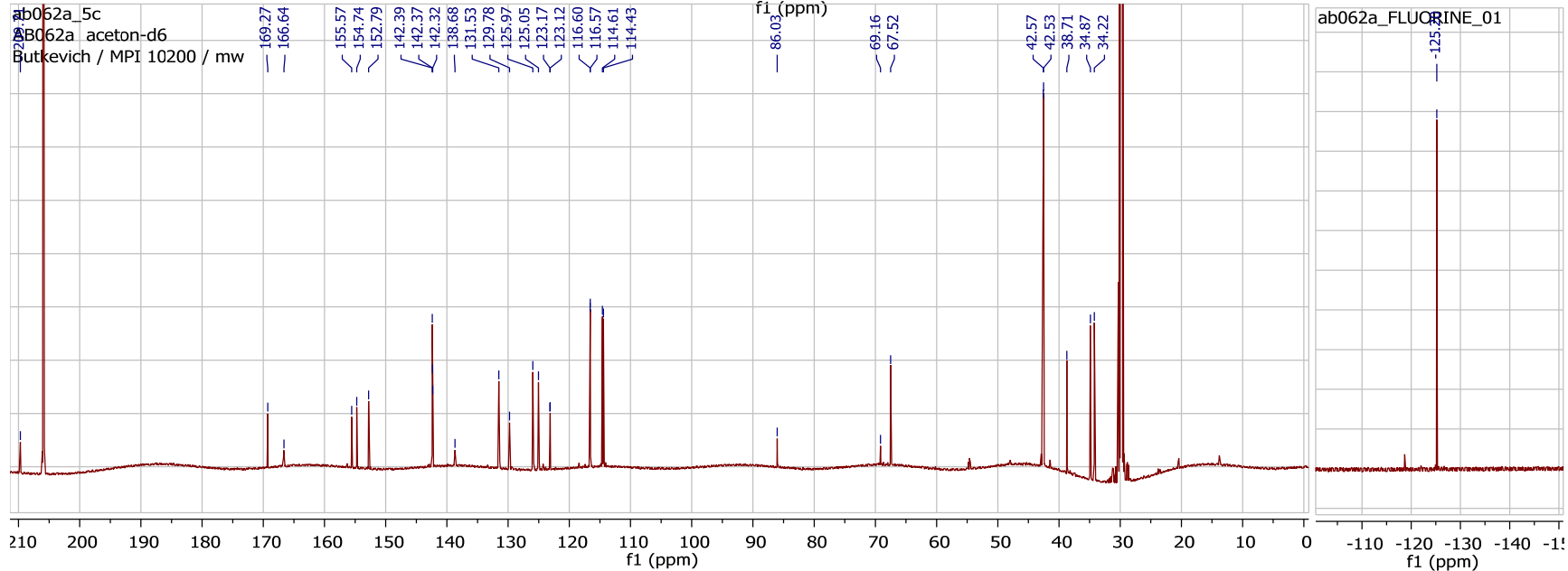
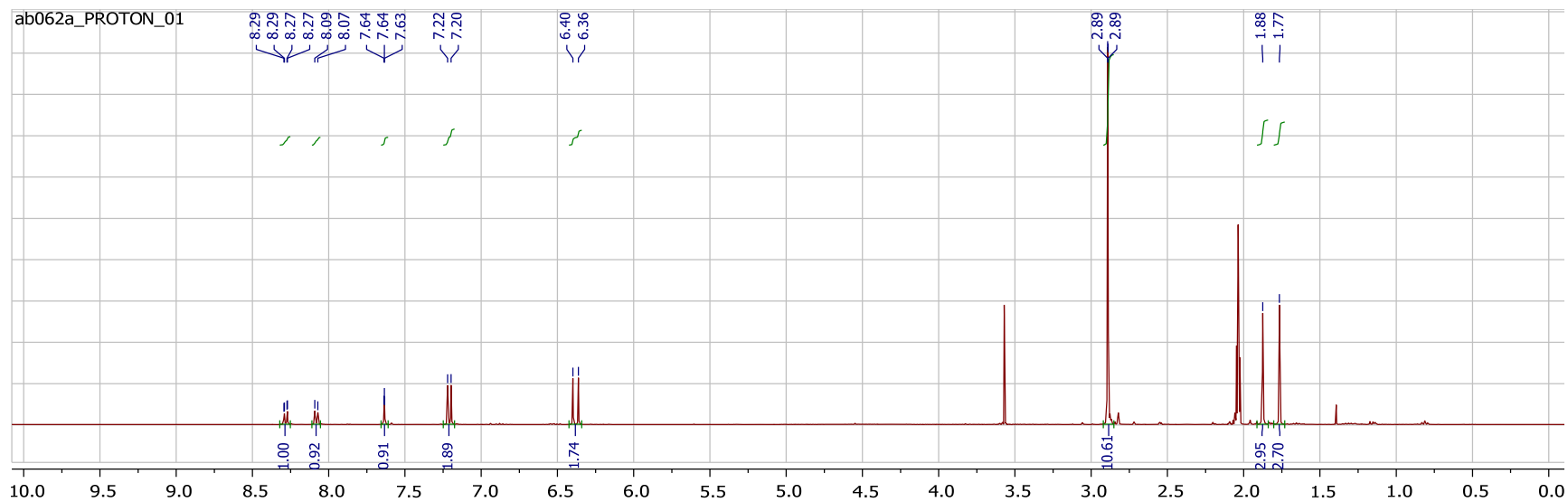

1h-Halo

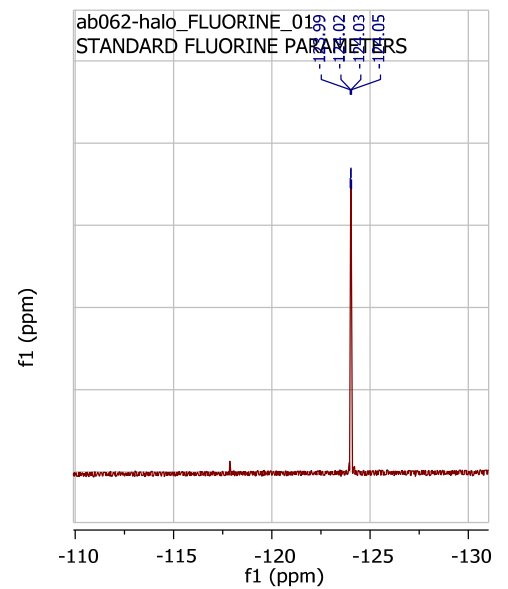
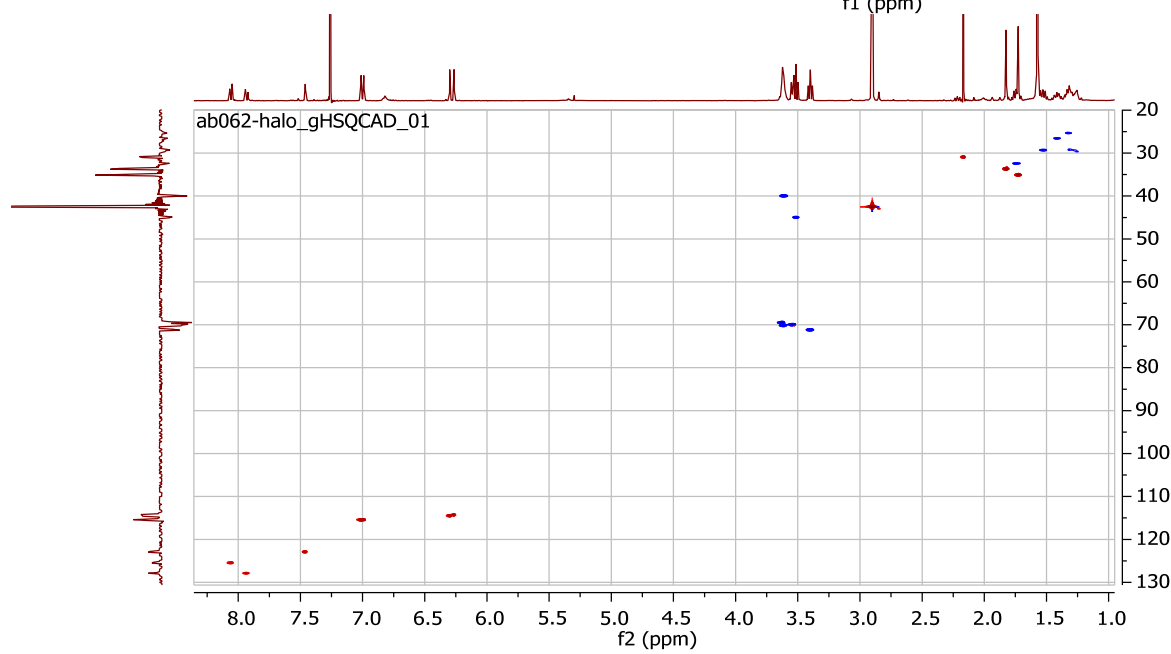
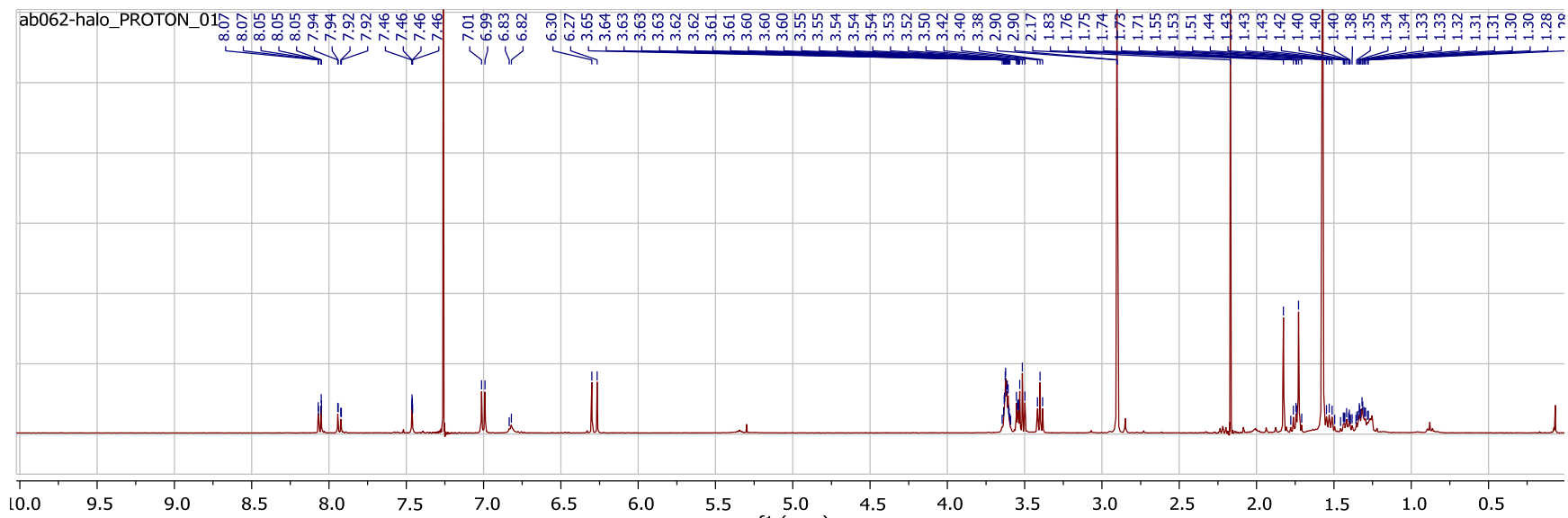

SI-17

ab063_PROTON_01

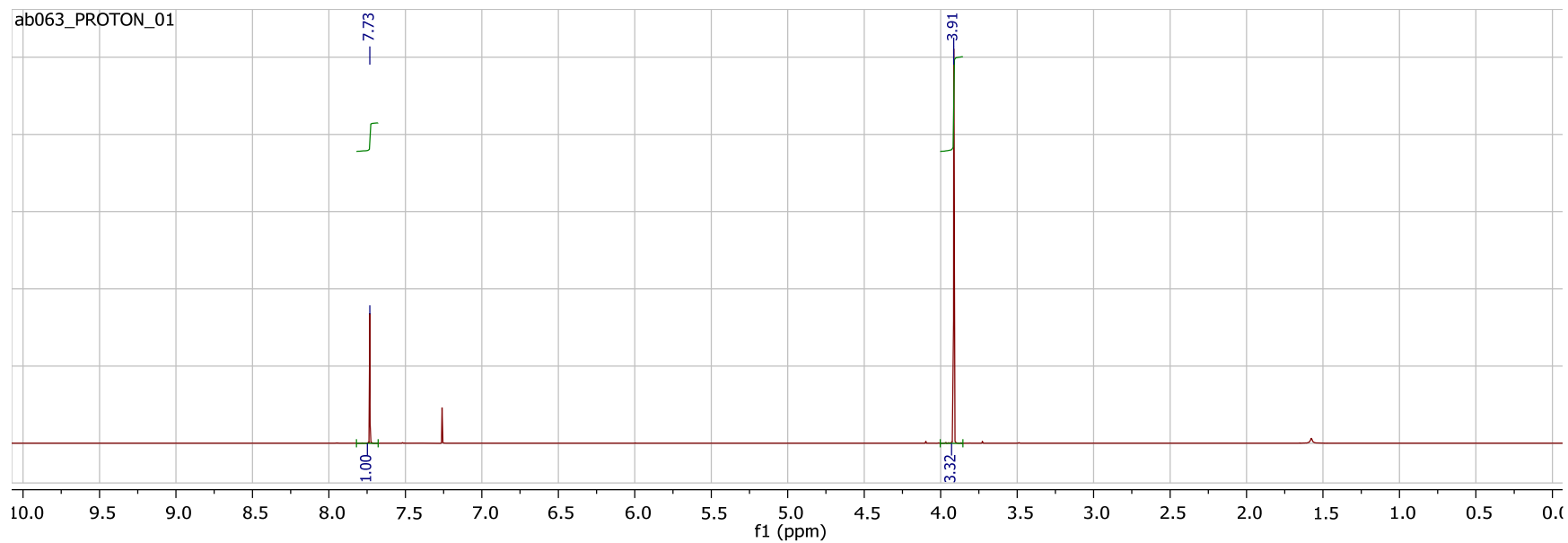

SI-18

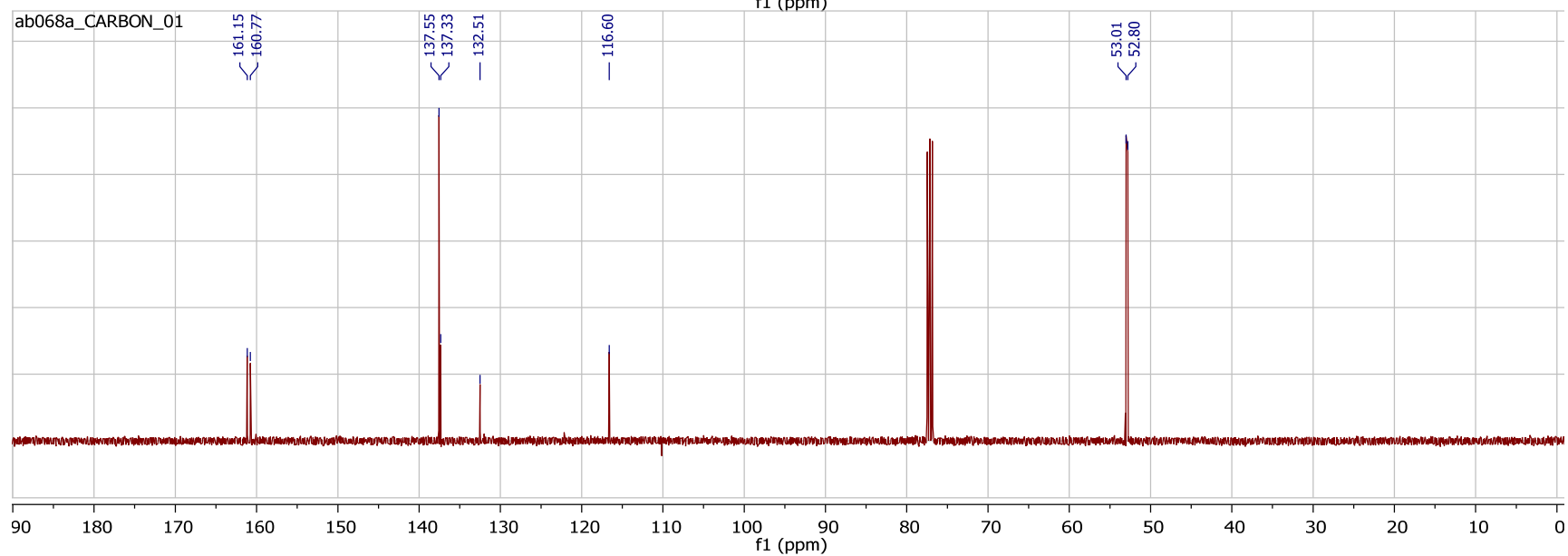
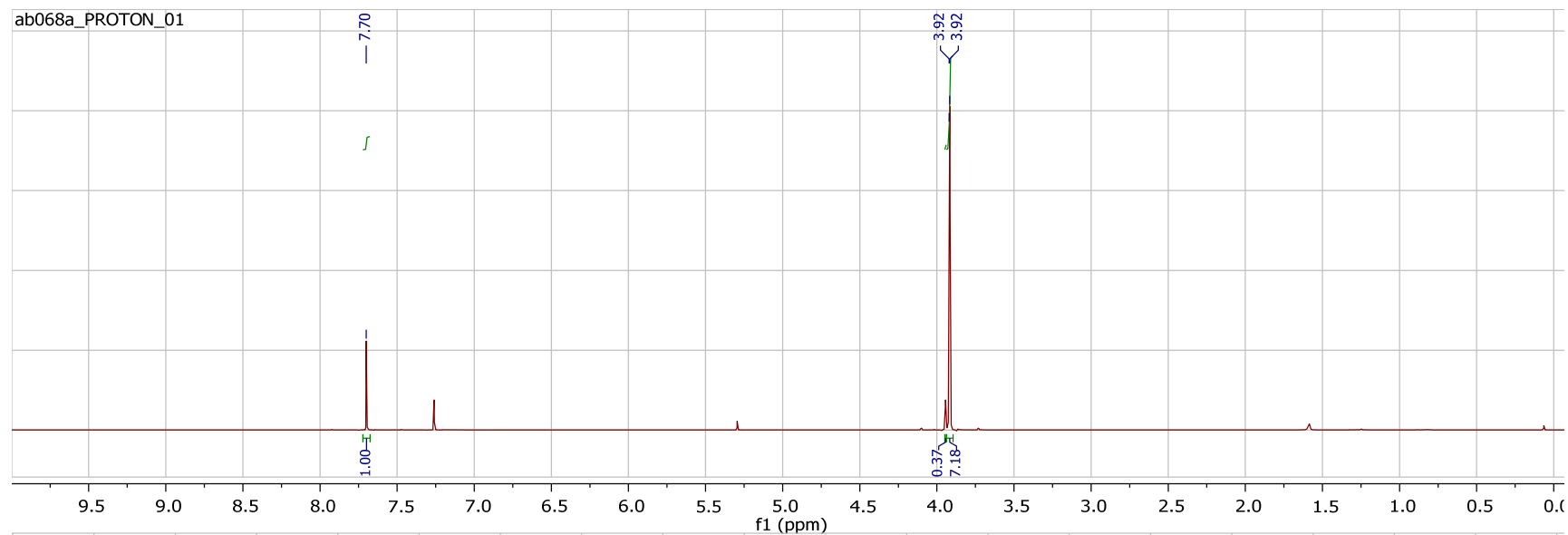

SI-19

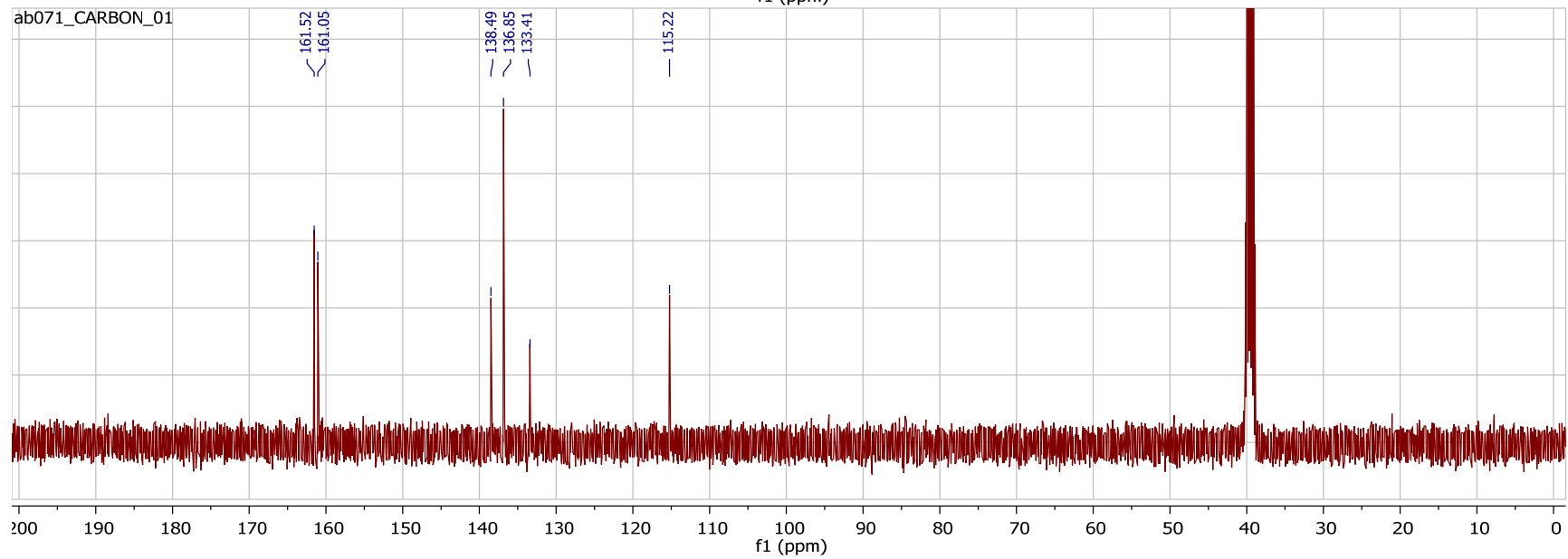
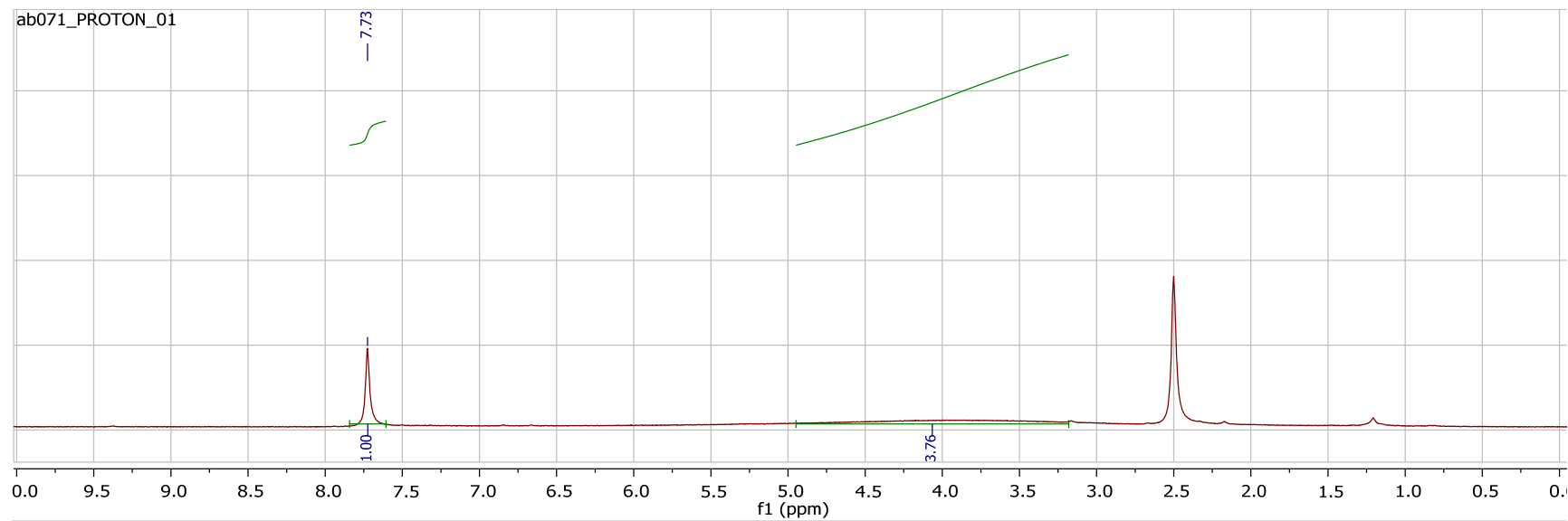

SI-20

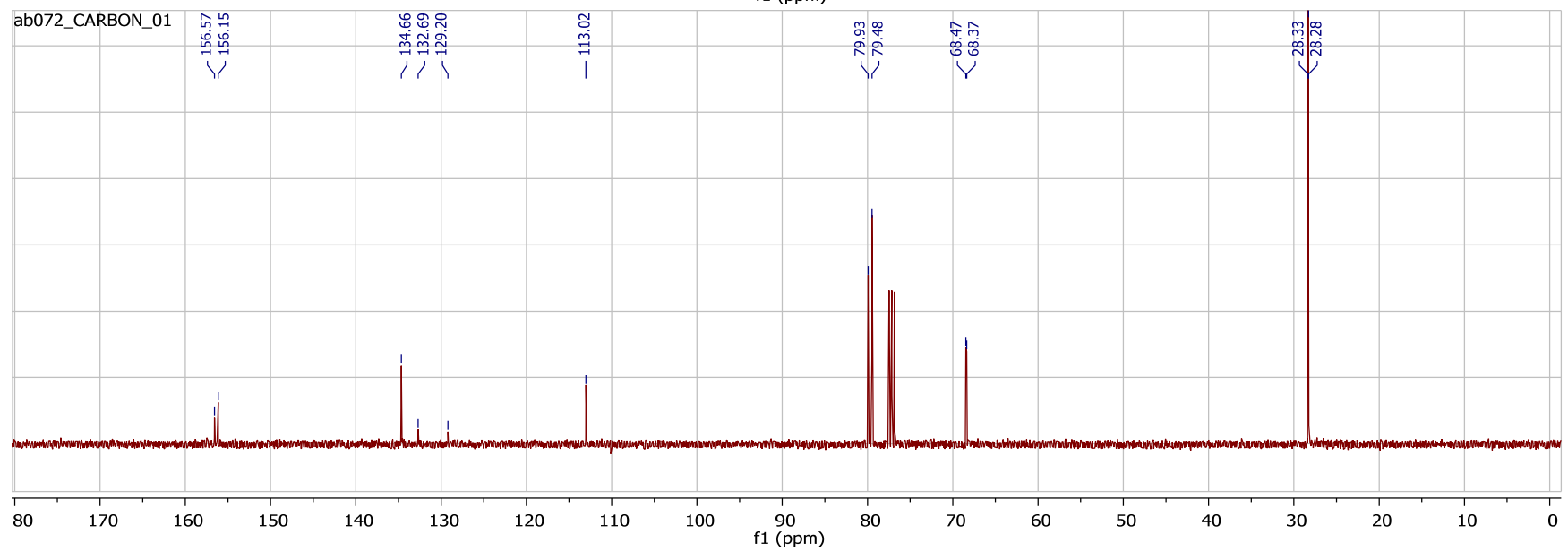
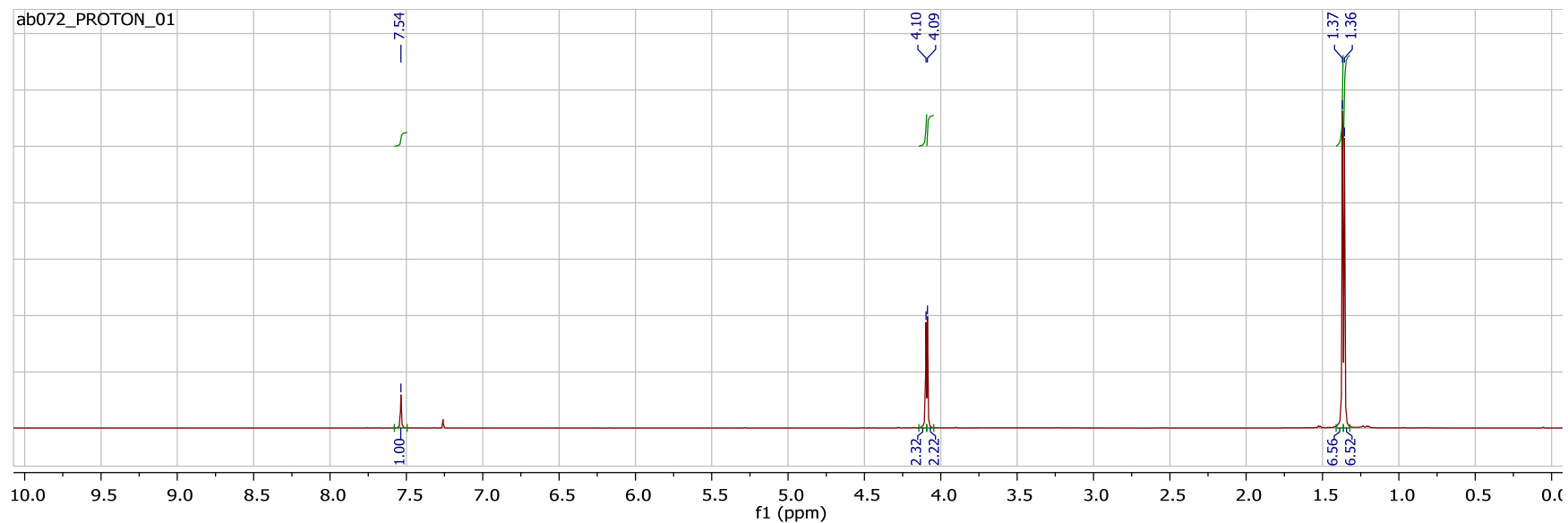

1j (650SiR)

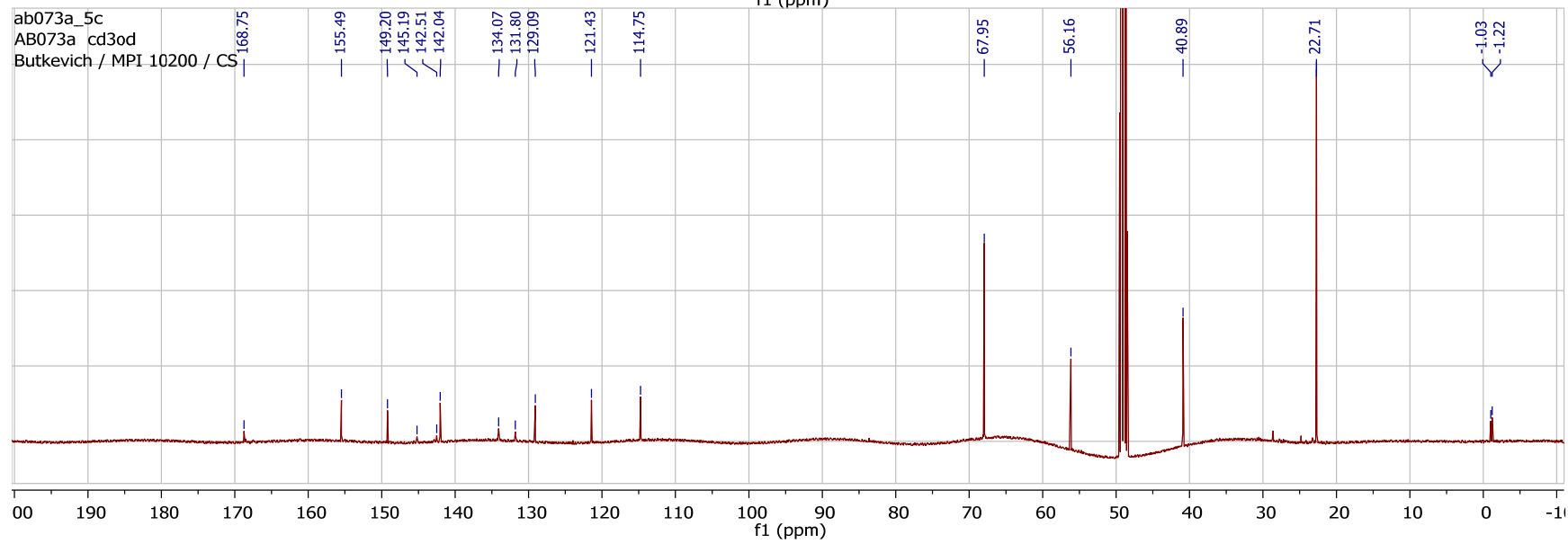
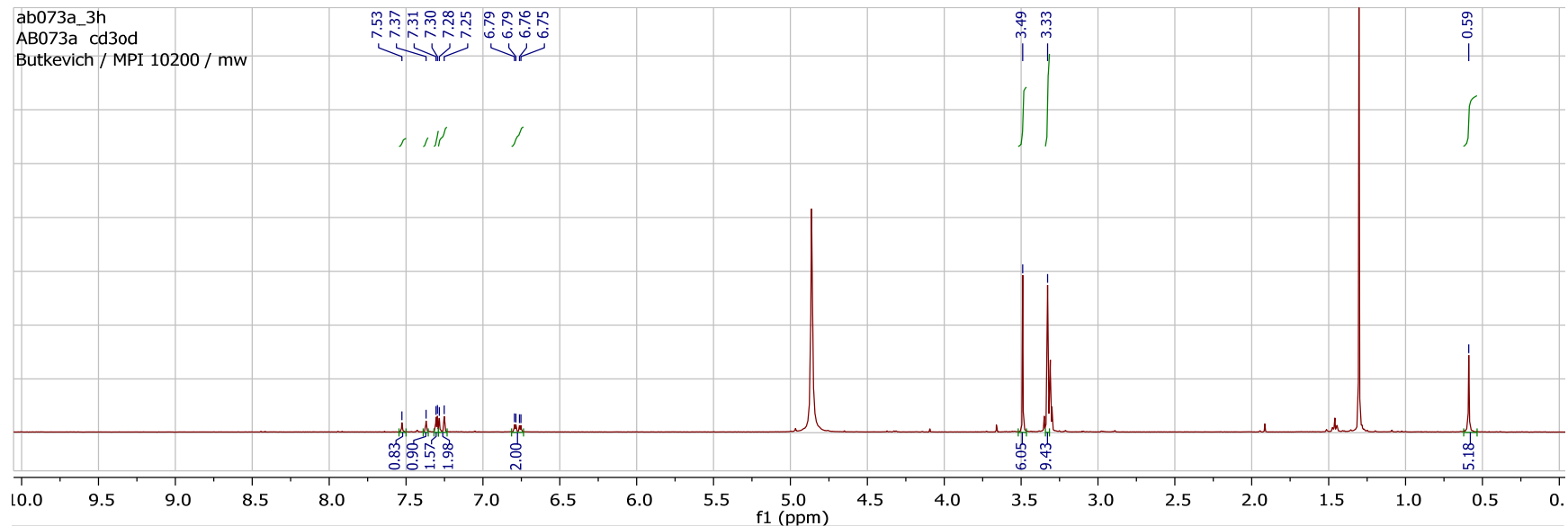

SI-22

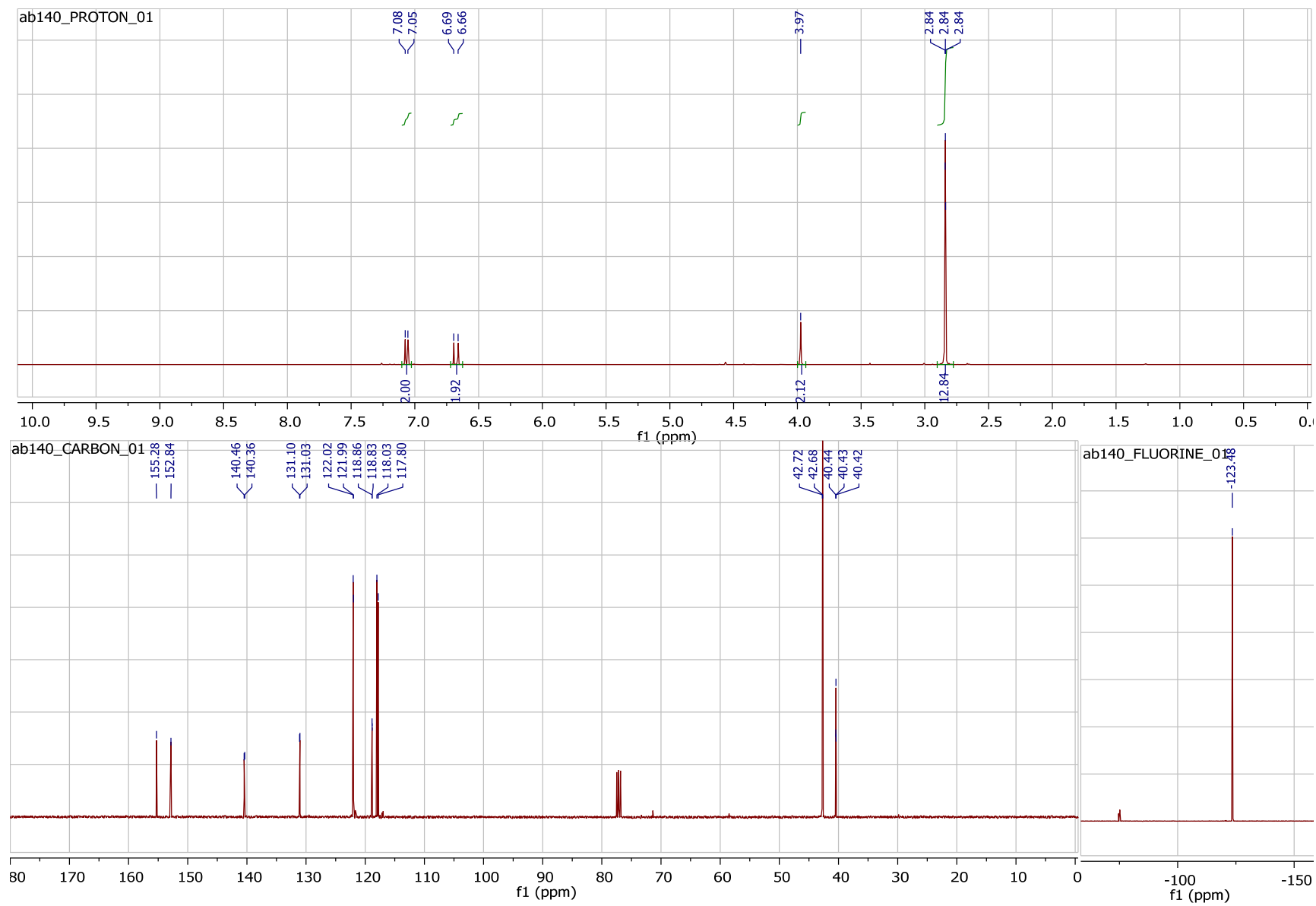

SI-23

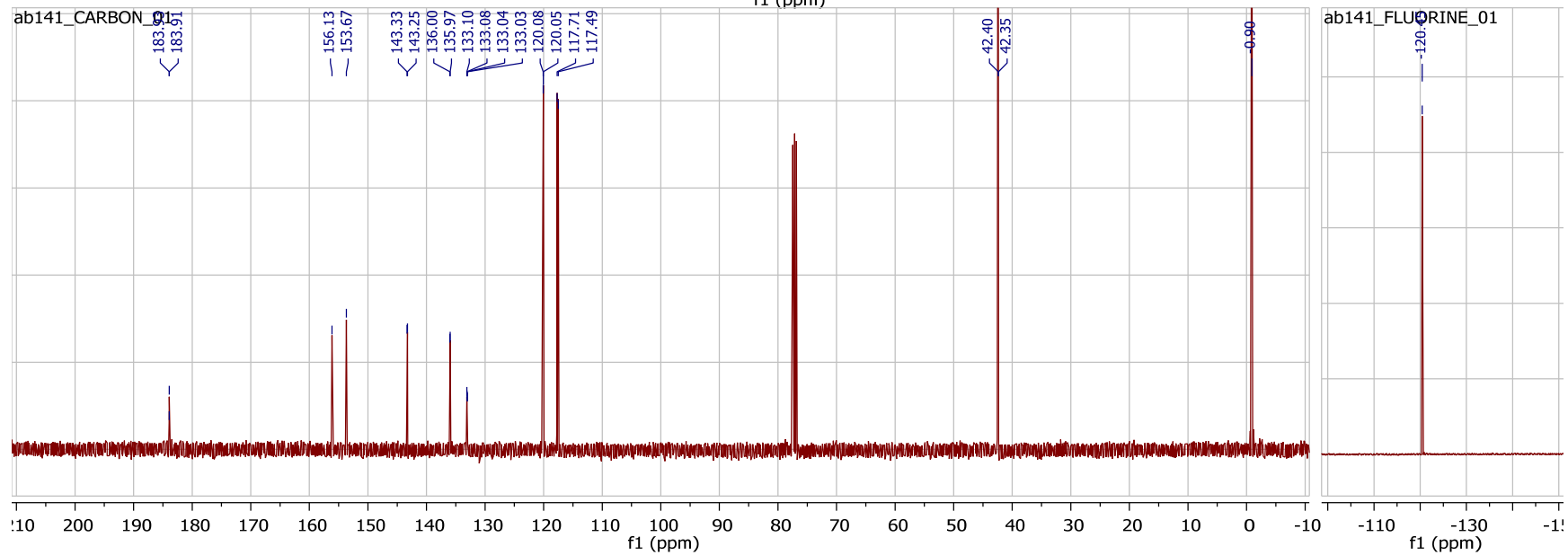
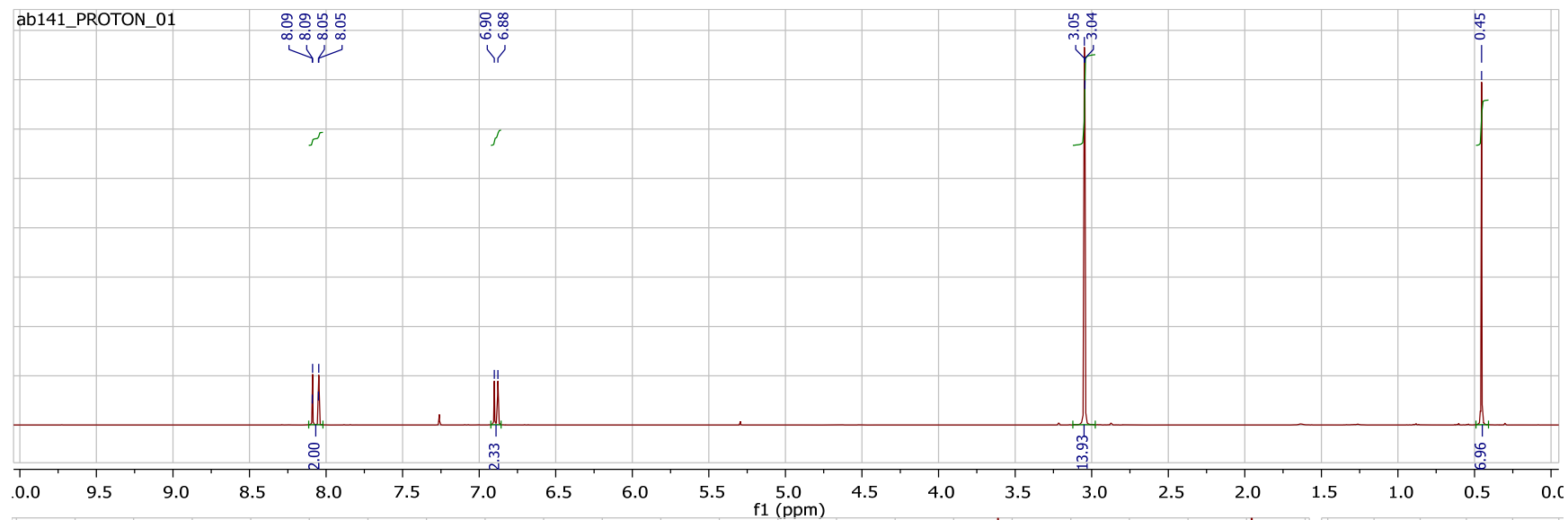

SI-24

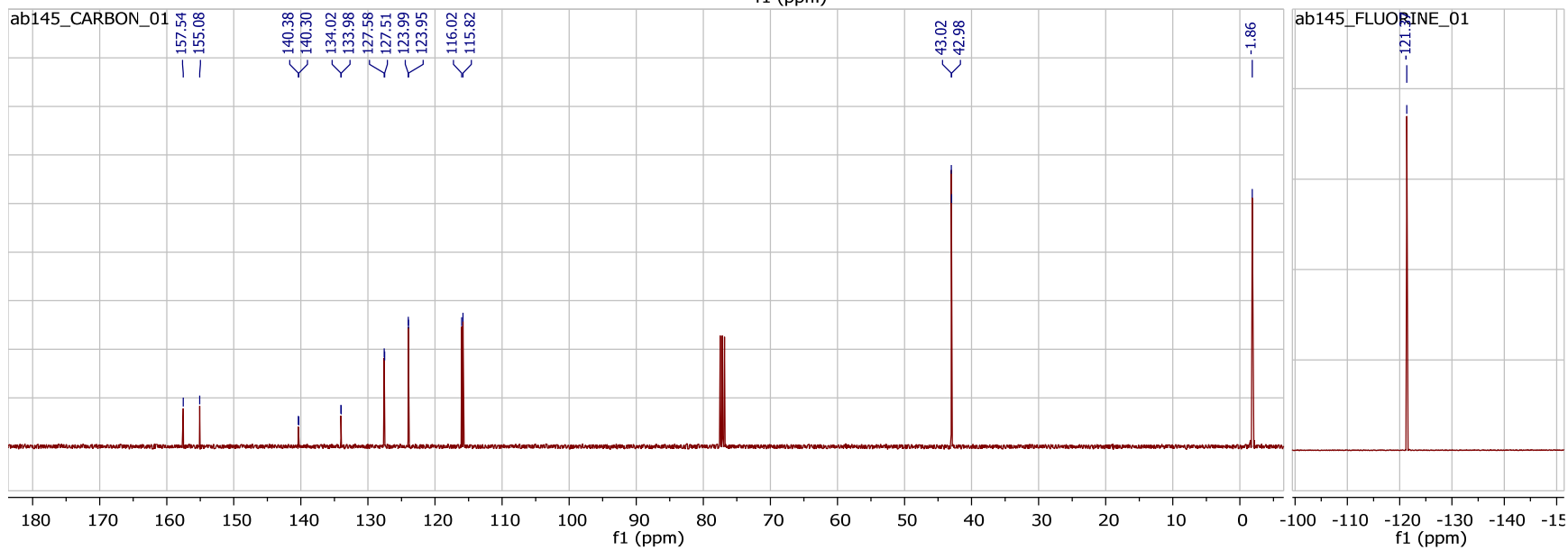
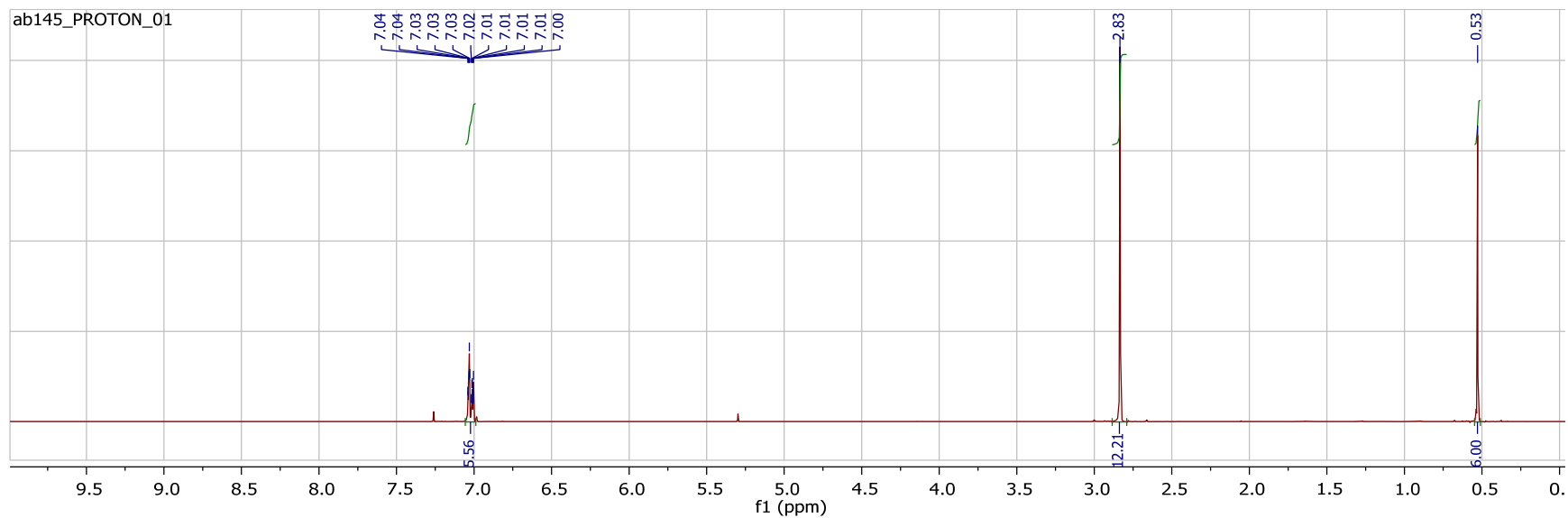

SI-25

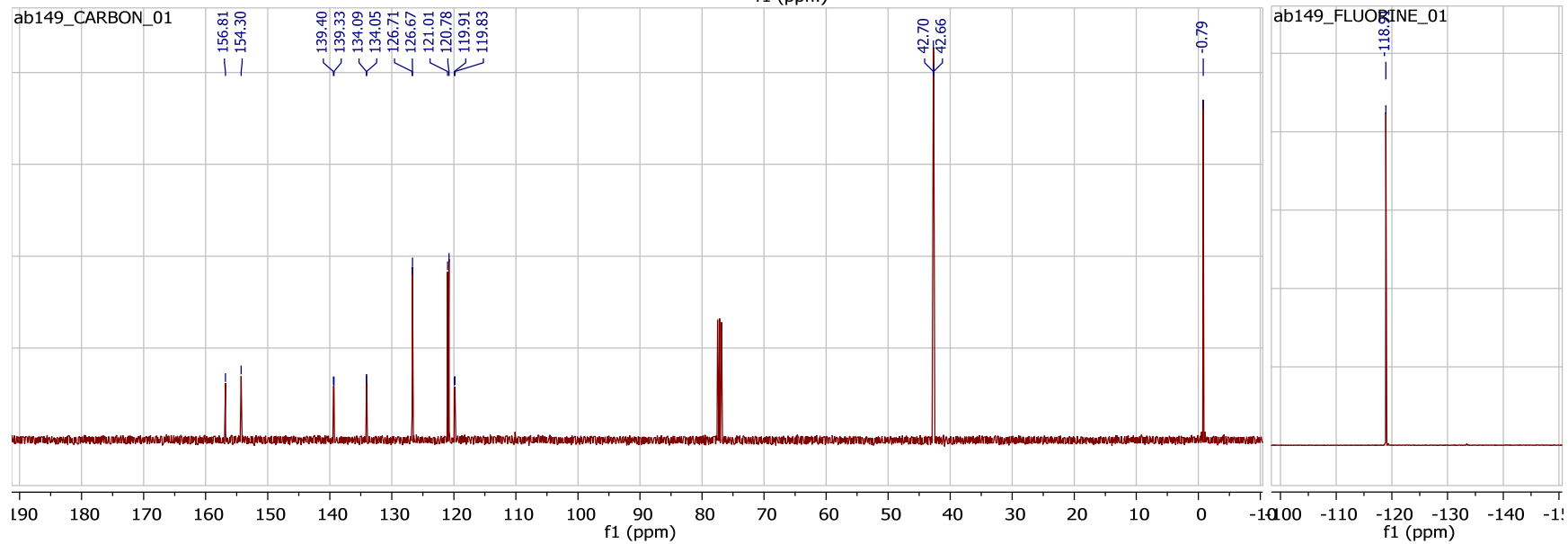
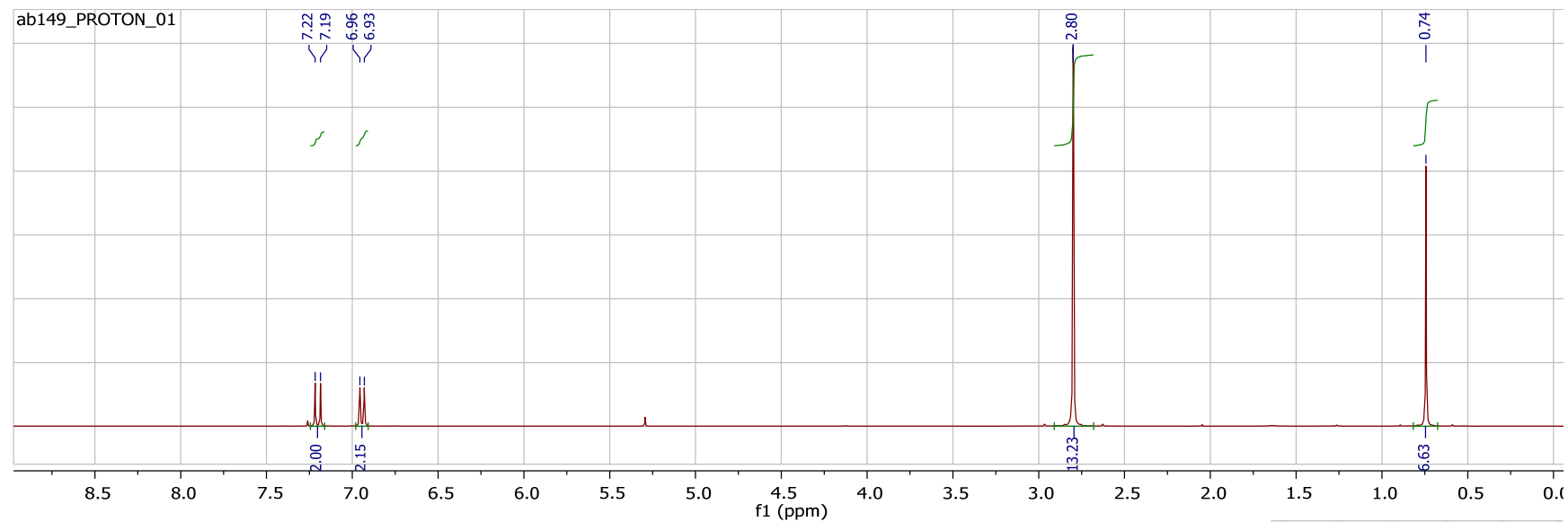

1k (670SiR)

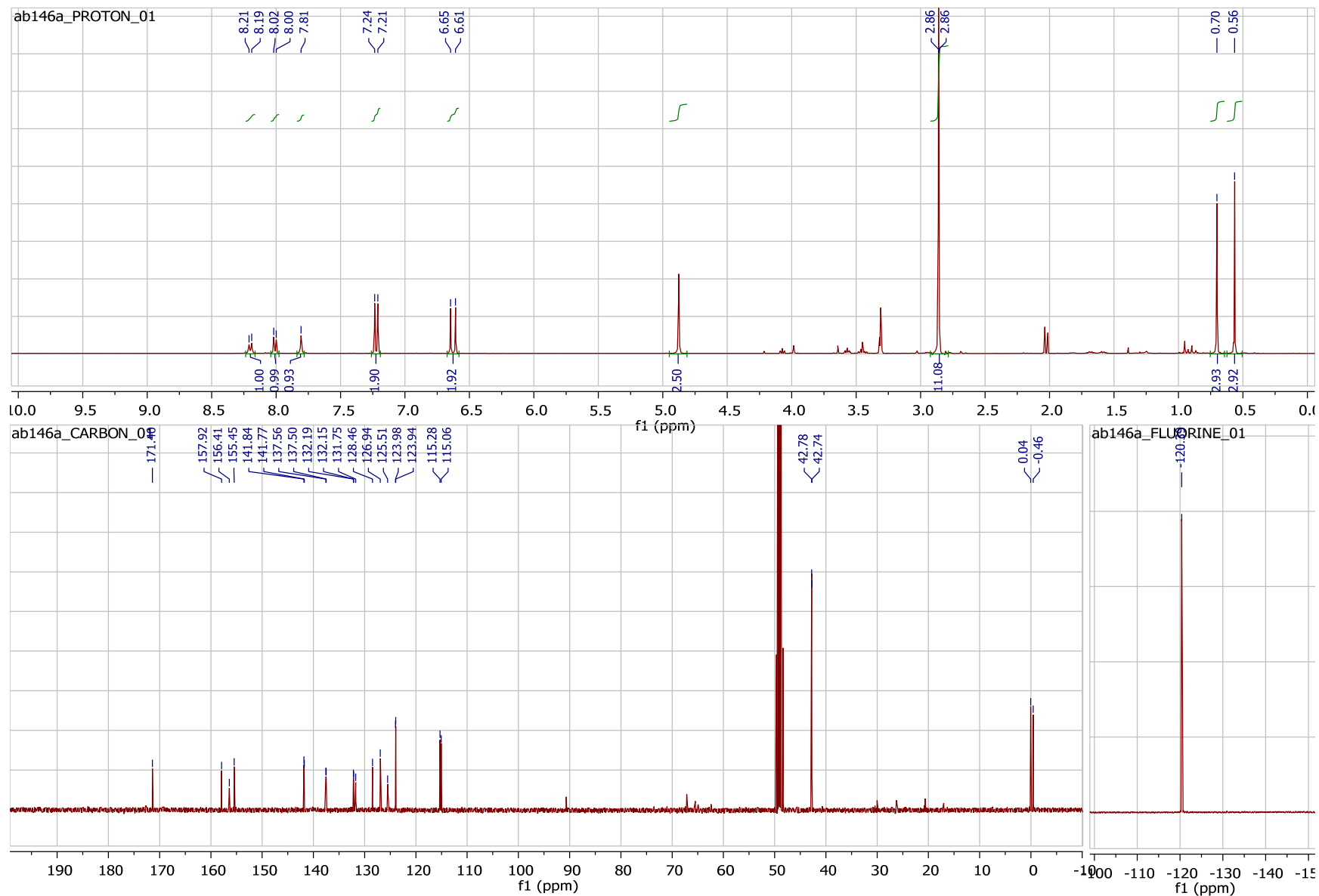

1k-Halo

