



Elise Goujard · Martin Möller

Counting Feynman-like graphs: Quasimodularity and Siegel–Veech weight

Received October 1, 2016

Abstract. We prove the quasimodularity of generating functions for counting torus covers, with and without Siegel–Veech weight. Our proof is based on analyzing decompositions of flat surfaces into horizontal cylinders. The quasimodularity arises from representing the generating series as a contour integral of quasi-elliptic functions. This provides an alternative proof of the quasimodularity results of Bloch–Okounkov, Eskin–Okounkov and Chen–Möller–Zagier, and generalizes the results of Böhm–Bringmann–Buchholz–Markwig for simple ramification covers.

Keywords. Quasimodular forms, Feynman graphs, Siegel–Veech constants, tropical covers, correspondence theorem

Contents

1. Introduction	365
2. Counting covers of elliptic curves by global graphs	368
3. Shifted symmetric polynomials and completed cycles	377
4. Hurwitz numbers and graph sums	378
5. Constant coefficients of quasi-elliptic functions	382
6. Quasimodularity of graph sums	391
7. Siegel–Veech constants	396
8. Tropical covers and quasimodularity graph by graph	400
9. Examples	403
References	411

1. Introduction

The generating series for counting the number of torus coverings first attracted attention with Dijkgraaf’s work [Dij95] on mirror symmetry for elliptic curves. It was shown rigorously by Kaneko–Zagier [KZ95] that these functions are quasimodular forms. This

E. Goujard: Laboratoire de Mathématiques d’Orsay, Université Paris-Sud,
F-91405 Orsay Cedex, France; e-mail: elise.goujard@gmail.com

M. Möller: Institut für Mathematik, Goethe-Universität Frankfurt, Robert-Mayer-Str. 6–8,
60325 Frankfurt am Main, Germany; e-mail: moeller@math.uni-frankfurt.de

Mathematics Subject Classification (2010): Primary 05E10; Secondary 11F11, 32G15, 14H30

statement was generalized by Eskin–Okounkov [EO01] from simple branch points to arbitrary branching profiles.

In this paper we show that the quasimodularity of counting functions generalizes in two ways. We first analyze to which extent the quasimodularity holds when counting the contributions of each underlying global graph separately. The precise statement requires a correspondence theorem between covers and decorated graphs. In the case of simple branching, the global graphs are trivalent and sometimes referred to as Feynman graphs. In this case our correspondence theorem boils down to the correspondence theorem for tropical Hurwitz numbers of torus covers proved in [BBBM17], as we explain in Section 8.

The second generalization counts coverings with a Siegel–Veech weight, motivated by Siegel–Veech constants for flat surfaces. Here again, our method provides a different approach and a refinement of the quasimodularity shown in [CMZ18], by counting the contribution of each (‘Feynman’) graph separately.

We give some motivation for why we care about quasimodularity statements. Obviously, knowing the first few coefficients of a quasimodular form determines the whole series and thus provides a computational approach to the counting problem. Second, the asymptotic behaviour of the coefficients of a quasimodular form is well-understood [CMZ18, Section 9]. Those coefficient asymptotics are important e.g. to compute the Masur–Veech volumes of moduli spaces of flat surfaces. Despite some recent advances ([AEZ16], [Gou16], [CMZ18]) many refined questions, concerning e.g. large genus asymptotics, spin structure distinction and Masur–Veech volumes of quadratic differential spaces in general, are still wide open. We plan to apply the techniques presented here to these cases in a sequel to this paper.

A covering $p : X \rightarrow E$ of the square torus provides X with a flat metric $\omega = p^*\omega_E$. The flat surface (X, ω) is swept out by horizontal cylinders. We obtain the *global graph of the covering* by letting the vertices be the branch points of p and the edges be those horizontal cylinders. Our correspondence theorem shows roughly that decorating the graph with widths and heights at the edges and with local data (triple Hurwitz numbers) at the vertices defines a bijection with the torus covers; see Proposition 2.4 for a precise statement. In the case of simple branching, our global graphs are the tropical covers of e.g. [BBBM17].

For counting problems the following special case of Theorem 5.8 is the core of quasimodularity statements.

Theorem 1.1. *Let P be a product of derivatives $\wp^{(m)}(z_i - z_j)$ of the Weierstrass \wp -function. Then the constant term¹ with respect to the variables $\zeta_j = e^{2\pi iz_j}$,*

$$[\zeta_n^0, \dots, \zeta_1^0]P = \frac{1}{(2\pi i)^n} \oint_{0+i\varepsilon_n}^{1+i\varepsilon_n} \dots \oint_{0+i\varepsilon_1}^{1+i\varepsilon_1} P(z_1, \dots, z_n; \tau) dz_1 \dots dz_n,$$

is a quasimodular form. More precisely, if P consists of ℓ factors, where the k -th factor involves the m_k -th derivative, then the quasimodular form has mixed weight less than or equal to $\sum_{k=1}^{\ell} (2 + m_k)$.

¹ We refer to Section 5.3 for the conventions on the ‘heights’ ε_i of integration paths.

Note that in general these constant terms are not of pure weight² as we show in the example in Section 5.4, even if all m_k are zero. The statement of the theorem above involves only the elliptic Weierstraß \wp -function. Nevertheless our proof requires Theorem 5.8 about the quasimodularity of constant terms for quasi-elliptic functions in full generality, since taking the coefficient $[\zeta_1^0]$ of an elliptic function may no longer be elliptic.

We let $N^\circ(\Pi) = \sum N_d^\circ(\Pi)q^d$ be the generating series for counting torus covers with branching profile Π . Our first geometric application is an independent proof of the following result of Kaneko–Zagier and Eskin–Okounkov, based on Theorem 1.1.

Theorem 1.2 (= Corollary 6.2). *For any ramification profile Π the counting function $N^\circ(\Pi)$ for connected torus covers of profile Π is a quasimodular form of mixed weight less than or equal to $|\Pi| + \ell(\Pi)$.*

The generating series $N^\circ(\Pi)$ can be decomposed as $\sum_\Gamma N^\circ(\Gamma, \Pi)$ according to the associated global graph Γ . In general, the individual contributions $N^\circ(\Gamma, \Pi)$ are not quasimodular forms: already genus 2 surfaces and Π consisting of a 3-cycle provides an example (see Section 9.1). Our method of proof gives a refinement of the quasimodularity statement for the case of simple branch points. Along with the interpretation in terms of tropical covers, in Section 8 we show

Theorem 1.3 (= Corollary 8.4). *In the case $\Pi = ((2), \dots, (2))$, for any trivalent graph Γ the contribution $N'(\Pi, \Gamma)$ of the graph Γ to the total counting is a quasimodular form of mixed weight at most $|\Pi| + \ell(\Pi)$.*

Siegel–Veech constants give the asymptotic number of immersed cylinders in a flat surface with bounded length of the waist curve. They are important characteristics of the dynamics of billiards and flat surfaces; see Section 7.1 for a brief summary and [EM01], [EMZ03], [CMZ18, Section 1] for more details. The Siegel–Veech constants for a general flat surface in a given stratum can be computed by determining the asymptotics of Siegel–Veech constants for spaces of torus covers. This in turn requires counting torus covers with a combinatorial constant, the Siegel–Veech weight (depending on an integer parameter $p \geq -1$), which we define in Section 7. In analogy with the simple counting problem we next define the generating series $c_p^\circ(\Pi)$ of Siegel–Veech weighted coverings. Showing that this series is a quasimodular form is important because of the good control of the coefficient asymptotics of quasimodular forms (see [CMZ18, Section 9]). Counting Siegel–Veech weighted graphs gives a new proof of the following theorem (see [CMZ18, Theorem 6.4]); its refinement in the trivalent case is stated in Corollary 8.4.

Theorem 1.4 (= Corollary 7.2). *For any ramification profile Π and any odd integer $p \geq -1$ the generating series $c_p^\circ(\Pi)$ for counting connected covers with p -Siegel–Veech weight is a quasimodular form of mixed weight at most $|\Pi| + \ell(\Pi) + p + 1$.*

We conclude with an outline of the proof of Theorems 1.2 and 1.4. By using the correspondence theorem (Proposition 2.4) our problem is converted into counting decorated

² Purity of the weight of the quasimodular form is claimed in Theorem 3.2 of [BBBM17], but it relies on Proposition 3.3 there, which has a gap.

graphs whose vertex labels are triple Hurwitz numbers. These are piecewise polynomials in the input data, i.e. the edge labels of the graph. If these were globally polynomials (as they are in the trivalent case), the graph sums can be interpreted as the constant coefficient of a polynomial in the Weierstraß \wp -function and its derivatives (see Proposition 6.7). The polynomiality can be restored using *completed cycles* p_k instead of the weighted symmetric group characters f_k in the Burnside formula for counting coverings. With the use of the notion of q -bracket and the fact that both f_k and p_k generate the algebra of shifted symmetric functions, the arguments of Section 4.1 allow one to come back to the true counting problem while maintaining quasimodularity.

Notation

For a partition $\lambda = (\lambda_1 \geq \lambda_2 \geq \dots)$ we let $|\lambda| = \sum_{i \geq 0} \lambda_i$ be the number that λ is a partition of, i.e., $\lambda \vdash |\lambda|$. We denote by $\ell(\lambda) = \max\{i; \lambda_i \geq 0\}$ the *length* of the partition. We also need its *weight* $\text{wt}(\lambda) = |\lambda| + \ell(\lambda)$. We adopt the corresponding notation for tuples, i.e. if $\mathbf{w} = (w_1, \dots, w_n)$ then $|\mathbf{w}| = \sum w_i$ and $n = \ell(\mathbf{w})$.

2. Counting covers of elliptic curves by global graphs

In this section we recall basic facts about enumeration of covers, both for torus coverings and coverings of the projective line with three marked points. The aim of this section is the correspondence theorem (Proposition 2.4) that gives a bijection between torus coverings and decorated graphs. This proposition holds at the level of covers *without unramified components only*, but (for a general branching profile) neither at the level of connected coverings nor at the level of all coverings. The statement requires setting up quite a bit of notation.

2.1. Covers of elliptic curves and their Hurwitz tuples

Here we recall basic facts about enumeration of covers using tuples of elements in the symmetric group. Our aim here is to explain the passage between the number of connected and disconnected coverings and to express these numbers in terms of characters of the symmetric group. We focus on torus coverings in this section.

Let $\Pi = (\mu^{(1)}, \dots, \mu^{(n)})$ consist of partitions $\mu^{(i)} = (\mu_1^{(i)}, \mu_2^{(i)}, \dots)$ such that each entry $\mu_j^{(i)}$ is a non-negative integer and for later use we define g by $\sum_{i,j} (\mu_j^{(i)} - 1) = 2g - 2$. We call such a tuple Π a *ramification profile*.

A covering $p : X \rightarrow E$ of the torus E has *ramification profile* Π if the covering has n numbered branch points and over the i -th branch point the sheets coming together form the partition $\mu^{(i)}$ (completed by singletons if $|\mu^{(i)}| < \deg(p)$). Let

$$\rho : \pi_1(E \setminus \{P_1, \dots, P_n\}) \rightarrow S_d$$

be the monodromy representation in the symmetric group of d elements associated with the covering p and some base point P , which we suppress in notation. We use the

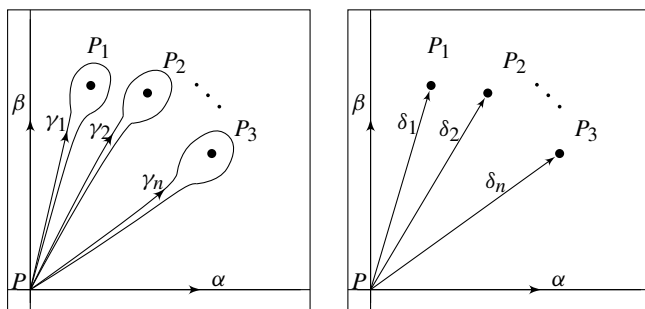

Fig. 1. Standard presentation of $\pi_1(E \setminus \{P_1, \dots, P_n\})$.

convention that loops (and elements of the symmetric group) are composed from right to left. The elements $(\alpha, \beta, \gamma_1, \dots, \gamma_n)$ as in Figure 1 generate the fundamental group $\pi_1(E \setminus \{P_1, \dots, P_n\})$ with the relation

$$\beta^{-1} \alpha^{-1} \beta \alpha = \gamma_n \cdots \gamma_1. \tag{1}$$

Given such a homomorphism ρ , we let $\alpha = \rho(\alpha)$, $\beta = \rho(\beta)$ and $\gamma_i = \rho(\gamma_i)$ and call the tuple

$$h = (\alpha, \beta, \gamma_1, \dots, \gamma_n) \in (S_d)^{n+2} \tag{2}$$

the *Hurwitz tuple* corresponding to ρ and the choice of generators. Our main goal is to count coverings, or rather the corresponding Hurwitz tuples, and so we let

$$\text{Hur}_d(\Pi) = \{H = (\alpha, \beta, \gamma_1, \dots, \gamma_n) \in (S_d)^{n+2} \text{ of profile } \Pi\}, \tag{3}$$

where we say that H has *profile* Π if the partitions $[\gamma_i]$ associated with conjugacy class of γ_i are equal to $\mu^{(i)}$ for $i = 1, \dots, n$. Here we use the general convention to call two partitions of different sizes $d_1 \leq d_2$ equal if they differ by $d_2 - d_1$ parts of length 1.

So far we have made no connectedness assumption, but we will ultimately be interested in counting connected coverings, hence with transitive monodromy representations. We indicate this subset by an upper circle. As an important technical intermediate notion we need covers without unramified components, indicated by a prime, so we let

$$\begin{aligned} \text{Hur}_d^\circ(\Pi) &= \{H \in \text{Hur}_d(\Pi) : \langle H \rangle \text{ acts transitively on } \{1, \dots, d\}\}, \\ \text{Hur}'_d(\Pi) &= \{H \in \text{Hur}_d(\Pi) : \langle \gamma_1, \dots, \gamma_n \rangle \text{ acts non-trivially on every } H\text{-orbit}\}. \end{aligned}$$

The corresponding counts of covers (as usual with weight $1/\text{Aut}(p)$) differ from the cardinalities of these sets of Hurwitz tuples by the simultaneous conjugation of the Hurwitz tuple, hence by a factor of $d!$. Consequently, we let

$$N_d(\Pi) = \frac{|\text{Hur}_d^\circ(\Pi)|}{d!}, \quad N'_d(\Pi) = \frac{|\text{Hur}'_d(\Pi)|}{d!}, \quad N_d^\circ(\Pi) = \frac{|\text{Hur}_d^\circ(\Pi)|}{d!}, \tag{4}$$

and package these data into the generating series

$$N(\Pi) = \sum_{d=0}^\infty N_d(\Pi) q^d, \quad N'(\Pi) = \sum_{d=0}^\infty N'_d(\Pi) q^d, \quad N^0(\Pi) = \sum_{d=0}^\infty N_d^\circ(\Pi) q^d. \tag{5}$$

From $|\text{Hur}_d(\Pi)| = \sum_{j=0}^d \binom{d}{j} |\text{Hur}'_j(\Pi)| |\text{Hur}_{d-j}(\Pi)|$ one deduces that

$$N'(\Pi) = N(\Pi)/N(). \tag{6}$$

In order to state the passage from connected counting to counting without unramified components we need to define the set of ramification points and its partitions. For $i \in \{1, \dots, n\}$ let $\mu_j^{(i)}$ for $j \in J = J(i)$ be the parts of $\mu^{(i)}$ of length greater than 1 and let

$$\mathcal{R}(\Pi) = \{(i, j); i \in \{1, \dots, n\} \text{ and } j \in J(i)\}$$

be the index set of ramification points of the profile Π . We let $\mathbb{P}(\mathcal{R})$ be the set of partitions of the set $\mathcal{R} = \mathcal{R}(\Pi)$ that are finer than the partition by different first index. For any part A of such a partition we let Π_A be the profile consisting of the partitions $\mu_A^{(i)} = \{\mu_j^{(i)} : (i, j) \in A\}$ grouped together according to A . We omit those i for which there is no j with $(i, j) \in A$, so that Π_A is a profile with n or fewer branch points.

Proposition 2.1. *The generating function for counting covers without unramified components can be expressed in terms of counting functions for connected covers as*

$$N'(\Pi) = \sum_{\alpha \in \mathbb{P}(\mathcal{R})} \prod_{A \in \alpha} N^\circ(\Pi_A).$$

Proof. Any covering p without unramified components induces a partition $\alpha \in \mathbb{P}(\mathcal{R})$ of the ramification points according to its connected components. We label the sheets of the covering and obtain the identity of the sets of Hurwitz numbers

$$|\text{Hur}'_d(\Pi)| = \sum_{\alpha \in \mathbb{P}(\mathcal{R})} \sum_{(d_A)_{A \in \alpha}} \binom{d}{(d_A)_{A \in \alpha}} \prod_{A \in \alpha} |\text{Hur}_{d_A}^\circ(\Pi_A)|,$$

from which the claim follows immediately. □

Since the summand $N^\circ(\Pi)$ appears on the right side, classical inclusion-exclusion allows one to invert this formula and to write $N^\circ(\Pi)$ as a linear combination of products of $N'(\Pi_A)$ for subsets A of \mathcal{R} .

With the aim of connecting counting problems with the representation theory of the symmetric group, we recall the classical Burnside Lemma (see e.g. [LZ04, Theorem A.1.10]) that the number of Hurwitz tuples with ramification profile Π is given by

$$|\text{Hur}_d(\Pi)| = d! \sum_{\lambda \in \mathcal{P}(d)} \prod_{i=1}^n f_{\mu^{(i)}(\lambda)}, \tag{7}$$

where a conjugacy class σ is completed with singletons to form a partition of $|\lambda|$, and

$$f_\sigma(\lambda) = z_\sigma \chi^\lambda(\sigma) / \dim \chi^\lambda. \tag{8}$$

Here z_σ denotes the size of the conjugacy class of σ and $\dim \chi^\lambda$ is the dimension of the representation λ . We also write f_k in the special case when σ is a k -cycle.

2.2. Covers of the projective line with three marked points

Covers $\pi : S \rightarrow \mathbb{P}^1$ of the projective line can, of course, also be described by their monodromy. The main point here is to introduce some notation and to highlight the fact

that we consider one of the points ($z = 1$) to have a fixed ramification profile given by a partition μ , whereas the ramification over the other two branch points ($z = 0$ and $z = \infty$) is prescribed by two ('input' and 'output') tuples of variables $\mathbf{w}^- = (w_1^-, \dots, w_{n^-}^-)$ and $\mathbf{w}^+ = (w_1^+, \dots, w_{n^+}^+)$.

We conclude again with the passage between the number of connected and disconnected coverings and expressions in terms of characters of the symmetric group.

The use of the terminology of double and triple Hurwitz numbers is not completely consistent in the literature. Most classically, *double Hurwitz numbers* count coverings with prescribed behaviour over two points and only simple branching besides. In e.g. [SSZ12] (which we will use later), this notion is generalized by allowing instead of simple branching several cycles of fixed length r . We call these *generalized double Hurwitz numbers*. We also need *triple Hurwitz numbers* that count covers with three prescribed ramification points. In the literature simple branch points might be allowed, but we will not need this case and do not consider it. We will frequently use the special case of triple Hurwitz numbers where the ramification profile over one of the points is a cycle. These are obviously (special cases of) generalized double Hurwitz numbers.

Our general notation convention is that Cov denotes a set of coverings, TR ('triple ramification') is the set of tuples describing the monodromy of a covering and A denotes the number of coverings, always with weight $1/\text{Aut}(\pi)$. We use here superscripts \circ and primes as in the previous section, to denote connected covers and covers without unramified components, respectively.

We need to highlight one more detail, the numbering of preimages of branch points. Suppose that $\deg(\pi) = d$. For a partition μ and a point $x \in \mathbb{P}^1$ we write $\pi^{-1}(x) = [\mu]$ if the cycles in $\pi^{-1}(x)$ agree with the partition μ , completed by ones to form a partition of d . We say that x has *unnumbered profile* μ in this case. If \mathbf{w} is a tuple of integers with $\sum w_i = d$, we may consider it as a partition $[\mathbf{w}]$ and write $\pi^{-1}(x) = [\mathbf{w}]$ to specify an unnumbered profile. More frequently we will write that the covering π has the property $\pi^{-1}(x) = \mathbf{w}$ and we will say that x has *numbered profile* \mathbf{w} over x if the covering comes with a labelling σ_x of $\pi^{-1}(x)$ such that at the i -th point, w_i sheets come together.

We will consider most of the time the profile over $z = 0$ and $z = \infty$ to be numbered and over $z = 1$ to be unnumbered. If all of these points have unnumbered profiles, we add the subscript 'un'.

Thus, we have explained the conventions for our notations

$$\text{Cov}_{\text{un}}(\mathbf{w}^-, \mathbf{w}^+, \mu) = \left\{ \pi : S \rightarrow \mathbb{P}^1; \deg(\pi) = \sum w_i^+ = \sum w_i^-, \right. \\ \left. \pi^{-1}(1) = [\mu], \pi^{-1}(0) = [\mathbf{w}^-], \pi^{-1}(\infty) = [\mathbf{w}^+] \right\} \quad (9)$$

and

$$\text{Cov}(\mathbf{w}^-, \mathbf{w}^+, \mu) = \left\{ (\pi : S \rightarrow \mathbb{P}^1, \sigma_0, \sigma_\infty); \deg(\pi) = \sum w_i^+ = \sum w_i^-, \right. \\ \left. \pi^{-1}(1) = [\mu], \pi^{-1}(0) = \mathbf{w}^-, \pi^{-1}(\infty) = \mathbf{w}^+ \right\} \quad (10)$$

for unnumbered and numbered coverings. The same notation convention is used for

$$\begin{aligned} \text{TR}_{\text{un}}(\mathbf{w}^-, \mathbf{w}^+, \mu) &= \{T = (\boldsymbol{\alpha}, \boldsymbol{\beta}, \boldsymbol{\gamma}) \in S_d^3; [\boldsymbol{\alpha}] = [\mathbf{w}^-], [\boldsymbol{\beta}] = [\mathbf{w}^+], [\boldsymbol{\gamma}] = \mu\}, \\ \text{TR}(\mathbf{w}^-, \mathbf{w}^+, \mu) &= \{(T = (\boldsymbol{\alpha}, \boldsymbol{\beta}, \boldsymbol{\gamma}), \sigma_0, \sigma_\infty); [\boldsymbol{\gamma}] = \mu, [\boldsymbol{\alpha}] = \mathbf{w}^-, [\boldsymbol{\beta}] = \mathbf{w}^+\} \end{aligned} \tag{11}$$

for Hurwitz tuples. Moreover, we denote by

$$\begin{aligned} A_{\text{un}}(\mathbf{w}^-, \mathbf{w}^+, \mu) &= \sum_{\pi \in \text{Cov}_{\text{un}}(\mathbf{w}^-, \mathbf{w}^+, \mu)} \frac{1}{\text{Aut}(\pi)} = \frac{1}{d!} |\text{TR}_{\text{un}}(\mathbf{w}^-, \mathbf{w}^+, \mu)|, \\ A(\mathbf{w}^-, \mathbf{w}^+, \mu) &= \sum_{\pi \in \text{Cov}(\mathbf{w}^-, \mathbf{w}^+, \mu)} \frac{1}{\text{Aut}(\pi)} = \frac{1}{d!} |\text{TR}(\mathbf{w}^-, \mathbf{w}^+, \mu)| \end{aligned} \tag{12}$$

the weighted numbers of Hurwitz tuples if $d = \sum w_i^+ = \sum w_i^-$, and we let $A(\mathbf{w}^-, \mathbf{w}^+, \mu) = 0$ if this condition does not hold.

As a consequence of the Burnside Lemma we can again write those cardinalities in terms of characters of the symmetric group as

$$\begin{aligned} A_{\text{un}}(\mathbf{w}^-, \mathbf{w}^+, \mu) &= \frac{z_{\mathbf{w}^-} z_{\mathbf{w}^+}}{d!^2} \sum_{|\lambda|=d} \chi_{\mathbf{w}^-}^\lambda \chi_{\mathbf{w}^+}^\lambda f_\mu(\lambda) \\ &= \left(\prod_i w_i^- \prod_i w_i^+ \prod_j r_j^- \prod_j r_j^+ \right)^{-1} \sum_{|\lambda|=d} \chi_{\mathbf{w}^-}^\lambda \chi_{\mathbf{w}^+}^\lambda f_\mu(\lambda) \end{aligned} \tag{13}$$

if $d = \sum_i w_i^+ = \sum_j w_j^-$, and zero otherwise, where r_j^\pm are the multiplicities of the parts of \mathbf{w}^\pm . Correspondingly,

$$A(\mathbf{w}^-, \mathbf{w}^+, \mu) = \frac{1}{\prod_i w_i^- \prod_i w_i^+} \sum_{|\lambda|=d} \chi_{\mathbf{w}^-}^\lambda \chi_{\mathbf{w}^+}^\lambda f_\mu(\lambda) \tag{14}$$

if $d = \sum_i w_i^+ = \sum_j w_j^-$, and zero otherwise. This formula is the point of departure for the counting problems.

As in the case of covers of elliptic curves, we conclude this section with a discussion of the passage between connected and disconnected versions.

Lemma 2.2. *The double Hurwitz number with no ramification point over $z = 1$ is*

$$A(\mathbf{w}^-, \mathbf{w}^+, \emptyset) = \frac{1}{\prod_i w_i^+} \delta_{\mathbf{w}^+}^{\mathbf{w}^-}. \tag{15}$$

Proof. This is a straightforward application of the second orthogonality relation for characters. □

Since a general disconnected cover can be decomposed as a disjoint union of a cover without unramified components and a collection of unramified covers (i.e. of cylinders), we obtain the following lemma.

Lemma 2.3. *The triple Hurwitz numbers can be written in terms of triple Hurwitz numbers without unramified components for subsets of the ramification profile as*

$$A(\mathbf{w}^-, \mathbf{w}^+, \mu) = \sum_{\substack{\mathbf{u}^+ \subset \mathbf{w}^+, \mathbf{u}^- \subset \mathbf{w}^- \\ |\mu| \leq |\mathbf{u}^-| = |\mathbf{u}^+|}} A'(\mathbf{u}^-, \mathbf{u}^+, \mu) A(\mathbf{w}^- \setminus \mathbf{u}^-, \mathbf{w}^+ \setminus \mathbf{u}^+, \emptyset), \quad (16)$$

where we have set $A(\emptyset, \emptyset, \emptyset) = 1$.

Consequently, we can apply inclusion-exclusion (or Möbius inversion) to this formula and write triple Hurwitz numbers without unramified components in terms of (disconnected) Hurwitz numbers. That is, there exists a Möbius function $M(\mathbf{u}^+, \mathbf{u}^-, \mathbf{w}^+, \mathbf{w}^-)$ such that

$$A'(\mathbf{w}^-, \mathbf{w}^+, \mu) = \sum_{\substack{\mathbf{u}^+ \subset \mathbf{w}^+, \mathbf{u}^- \subset \mathbf{w}^- \\ |\mu| \leq |\mathbf{u}^-| = |\mathbf{u}^+|}} M(\mathbf{u}^+, \mathbf{u}^-, \mathbf{w}^+, \mathbf{w}^-) A(\mathbf{u}^-, \mathbf{u}^+, \mu). \quad (17)$$

2.3. Global graphs and cylinder decompositions

We now suppose moreover that the base of the covering p is the square torus $E = \mathbb{C}/(\mathbb{Z} + i\mathbb{Z})$ and p is a cover without unramified components. We fix the holomorphic one-form ω_E on E with period lattice $\Lambda = \mathbb{Z} + i\mathbb{Z}$ and provide X with the flat structure $\omega = p^*\omega_E$. To such a situation we will associate a graph with decorations as follows. The horizontal foliation of ω is completely periodic. From each homotopy class of horizontal cylinders c we select one representative, the core curve γ_c . We let $X^0 = \setminus \bigcup_c \gamma_c$ be the complement of all the core curves. For merely counting covers the precise location of the branch points is irrelevant. For concreteness, we use the *branch point normalization* that the i -th branch point has fixed coordinates $z_i = x_i + \sqrt{-1} \varepsilon_i$ with $0 \leq \varepsilon_1 < \dots < \varepsilon_n < 1$ and any $x_i \in [0, 1)$.

The *global graph* Γ associated with the flat surface $(X, \omega = p^*\omega_E)$ of ramification profile Π is the graph Γ with $n = |\Pi|$ vertices, labelled by $1, \dots, n = |\Pi|$ (see Figure 2). The edges $E(\Gamma)$ of Γ are in bijection with the core curves. An edge e connects the vertices i and j if the connected components of X^0 adjacent to the core curve $\gamma(e)$ contain ramification points lying over the i -th and j -th branch points in E . Note that this is well-defined by branch point normalization, which rules out that the p -images of two ramification points have the same height. The case $i = j$, i.e. self-edges, is of course possible.

To give an alternative definition, if each $\mu^{(i)}$ in the profile Π is a d -cycle, the global graph is just the dual graph of the stable curve of the curve obtained by degenerating the surface X in the horizontal direction, i.e. by applying $\text{diag}(e^t, e^{-t})$. In the general case, the global graph is the quotient graph of this dual graph, obtained by identifying the vertices whose corresponding branch point have the same number (in $1, \dots, n$).

We provide Γ with an orientation as follows and write $G \in \Gamma$ for the oriented graph. Fix an oriented closed loop on E (e.g. a vertical straight line), intersecting the horizontal straight line once. Preimages of this loop are paths in X , each crossing precisely one core

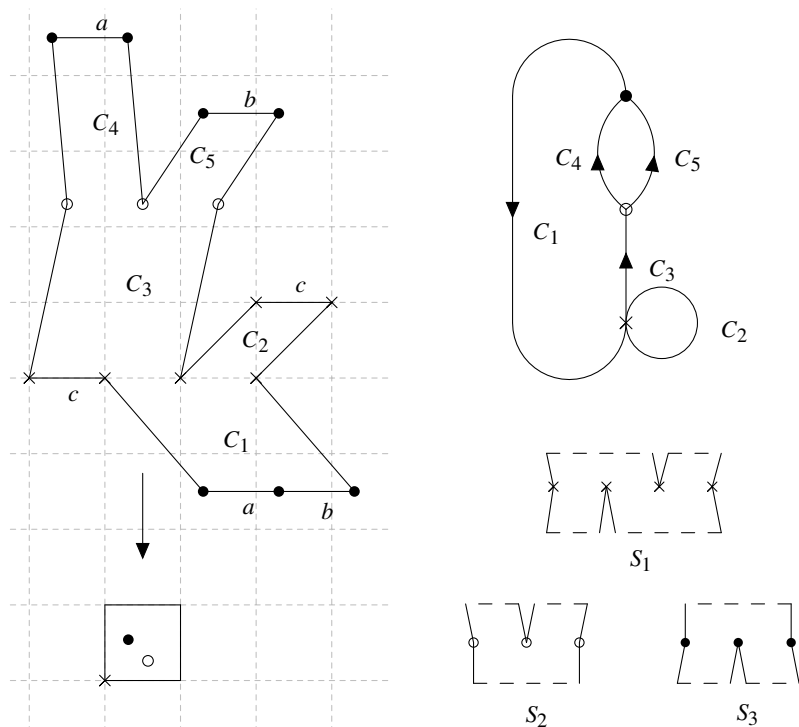

Fig. 2. A torus cover, its global graph, and the local surfaces.

curve γ_c , and we orient the corresponding edge of Γ in the direction of this loop. Self-edges are not given any orientation. Note that this orientation is well-defined by p up to flipping all arrows of G .

We call the union of connected components of X^0 that carry the same label the *local surfaces* of (X, ω) . We label these local surfaces also by an integer in $\{1, \dots, n\}$ according to the ramification point they carry. This labelling is well-defined, since p is a cover without unramified components.

To reconstruct a torus-covering flat surface from a global graph, we need two extra data that encode the geometry of the cylinders and the geometry of the local surfaces, respectively.

Each cylinder (corresponding to an edge e) has an integral positive width w_e and a real positive height h_e . The heights h_e are not arbitrary, but related to the position of the branch points. For an edge $e \in E(\Gamma)$ we denote by $i^+(e)$ (resp. $i^-(e)$) the label of the terminal (resp. initial) vertex of the edge e . It is obvious from the construction that the tuple $(h_e)_{e \in E(\Gamma)}$ of heights belongs to the *height space*

$$\tilde{\mathbb{N}}^{E(G)} = \{(h_e)_{e \in E(\Gamma)}; h_e - \Delta(e) \in \mathbb{N}\}, \tag{18}$$

where $\Delta(e) = \varepsilon_{i^+(e)} - \varepsilon_{i^-(e)}$ if $i^+(e) \geq i^-(e)$ and $\Delta(e) = 1 + \varepsilon_{i^+(e)} - \varepsilon_{i^-(e)}$ otherwise.

The last piece of local information for a cylinder is the *twist* $t_e \in \mathbb{Z} \cap [0, w_e - 1]$. The twist depends on the choice of ramification points $P^-(e)$ and $P^+(e)$ in each of the two components adjacent to the cylinders and it is defined as the integer part of the real part $[\Re(\int_S \omega)]$ of the integral along the unique straight line joining $P^-(e)$ to $P^+(e)$ such that $t_e \in [0, w_e - 1]$. The exact values of the twist will hardly matter below. It is important to remember simply that there are w_e possibilities for the twist in a given cylinder.

We now encode the local geometry on the complement of the core curves. The restriction of the cover p to any local surface is metrically a cover of an infinite cylinder, branched over one point only. In other words, for any vertex $v \in V(\Gamma)$ the (possibly disconnected) local surface $S = S_v$ can be described as a covering $\pi : S \rightarrow \mathbb{P}^1$, ramified over $z = 0, z = 1$ and $z = \infty$ only. The restriction of ω to S is the pullback of the infinite metric cylinder dz/z . The ramification profile of π consists

- over $z = 0$ of the widths w_e of the incoming edges at v ,
- over $z = \infty$ of the widths w_e of the outgoing edges at v , and
- over $z = 1$ of the subset of the branching profile $\mu^{(i)}$, where i is the label of v .

Proposition 2.4. *Up to the action of the group $\text{Aut}(\Gamma)$ of automorphisms of the labelled graph Γ there is a bijective correspondence between*

- (i) *the flat surfaces (X, ω) with covering $p : X \rightarrow E$ of degree d of the square torus E without unramified components and with $\omega = \pi^* \omega_E$, and*
- (ii) *the isomorphism classes of tuples $(G, (w_e, h_e, t_e)_{e \in E(G)}, (\pi_v)_{v \in V(G)})$ consisting of*

- *a global graph Γ with marked vertices and without isolated vertices together with an orientation $G \in \Gamma$,*
- *a collection $(w_e, h_e, t_e)_{e \in E(G)}$ of real numbers representing the width, height and twist of the cylinder corresponding to e ; the widths w_e are integers, the tuple $(h_e)_{e \in E(G)} \in \tilde{\mathbb{N}}^{E(G)}$ of heights is in the height space, $t_e \in \mathbb{Z} \cap [0, w_e - 1]$ and these numbers satisfy*

$$\sum_{e \in E(G)} w_e h_e = d, \tag{19}$$

- *a collection $(\pi_v)_{v \in V(G)}$ of \mathbb{P}^1 -coverings without unramified components, with $\pi_v \in \text{Cov}'(\mathbf{w}_v^-, \mathbf{w}_v^+, \mu_v)$ where \mathbf{w}_v^- is the tuple of widths at the incoming edges at v , \mathbf{w}_v^+ is the tuple of widths at the outgoing edges at v , and μ_v is the ramification profile given by the labels at v .*

Note that an automorphism of the labelled graph Γ preserves the vertices, i.e. it simply permutes the sets of edges sharing the same endpoints.

Proof of Proposition 2.4. To each covering p we can canonically associate the global graph Γ with vertex labels according to the branch point numbering and with widths w_e as above. The rest of the correspondence is not canonical but depends on three auxiliary choices. First, we provide Γ with the orientation G given by the upward pointing vertical direction. Second, we move the branch points so that they satisfy the branch point normalization. Third, we choose for each edge of Γ a pair of singularities in the local surfaces adjacent to the corresponding cylinder, one on each side.

We observe that these additional data can also obviously be recorded together with the tuples listed in (ii) so that it suffices to establish a bijection with the additional data on both sides and to see that the numbers of forgetful maps of the additional data are the same on both sides of the correspondence.

For the second task we remark that from any point in the height space we recover, by reducing mod 1, the heights up to a common translation (mod 1) by a real number. But the heights are only well-defined up to this ambiguity of translation anyway. The number of choices of the singularities adjacent to each cylinder agrees on both sides of the correspondence, in fact this number is $\prod_{v \in V(G)} \ell(\mathbf{w}_v^-) \ell(\mathbf{w}_v^+)$.

Note that the labelling of the vertices gives a natural partial numbering of the edges, by proceeding lexicographically, i.e. first numbering all edges between vertex 1 and vertex 2 etc. The number of choices to complete this to a full numbering of the edges is precisely $|\text{Aut}(\Gamma)|$.

The correspondence with the additional datum of an edge numbering has basically been given prior to the statement of the proposition: We use the pair of zeros adjacent to each cylinder to single out a saddle connection up to Dehn twist along the core curve of the cylinder. There is a unique representative in such a class that has holonomy $t_e + ih_e$ with $t_e \in \mathbb{Z} \cap [0, w_e - 1]$. Moreover, we use the numbering of the edges to order the tuple of incoming and outgoing cylinders in each local surface, i.e. to make \mathbf{w}^\pm an ordered tuple rather than a set of integers. This numbering also defines, for every local surface, an identification σ_0 (resp. σ_∞) of the branch points over zero (resp. ∞) with an element in the tuple \mathbf{w}^- (resp. \mathbf{w}^+), so that the local covering maps π_v are in $\text{Cov}'(\mathbf{w}_v^-, \mathbf{w}_v^+, \mu_v)$ rather than in the unordered version of this set of coverings. Note also that the prime is justified here, since the local covering is without unramified components, by definition of components of the local surfaces as components of X^0 .

For the converse correspondence, it suffices to wield together the local surfaces along a cylinder for each edge of G , where the identifications σ_∞ of $v^-(e)$ and σ_0 of $v^+(e)$ determine which branches of the local surfaces are glued together. The widths w_e and heights h_e determine the shape of the cylinder, and the twist together with the choice of a reference point on each side determines the way the cylinder is glued in. The action of an element in $\text{Aut}(\Gamma)$ simply changes σ_∞ and σ_0 by post-composition. Consequently, any two tuples in the same $\text{Aut}(\Gamma)$ -orbit give the same covering. \square

Similar statements hold neither at the level of connected covers of graphs nor at the level of general graphs without major changes. The problem in the connected case is that some local surfaces might be disconnected while assembling to a connected flat surface in general. The problem in the disconnected case is that a covering of a local surface with an unramified component can give rise to a flat surface that is also obtained by assembling only connected local surfaces. To construct the corresponding graph without unramified components, the unramified local piece has to be piled on top of the appropriate cylinder and so it can be disposed of.

The above correspondence still gives a bijection if both sides are weighted with their automorphism group.

Proposition 2.5. *In the correspondence of Proposition 2.4, an automorphism φ of the cover π defines a collection $(\varphi_v)_{v \in V(G)}$ of automorphisms of the local surfaces.*

Conversely, each collection $(\varphi_v)_{v \in V(G)}$ of automorphisms of the local surfaces defines an automorphism φ of the covering π .

Again, the correspondence is not canonical but depends on the choice of an auxiliary edge labelling.

Proof of Proposition 2.5. Any automorphism φ of π preserves the marked points in E and hence the vertices of Γ . Moreover, it maps cylinders to cylinders and thus induces an automorphism φ_Γ of the graph, preserving vertices. Let $\ell : E(G) \rightarrow \{1, \dots, |E(G)|\}$ be some auxiliary labelling of the edges of Γ . If we provide edges of the global graph of $\pi \circ \varphi$ with the labelling $\ell \circ \varphi_\Gamma$, then the restriction of φ to each local surface S_v is an automorphism φ_v that preserves the labelling σ_0 and σ_∞ of the preimages of zero and ∞ .

The converse of this procedure obviously works as well. □

3. Shifted symmetric polynomials and completed cycles

Let $f : \mathbb{P} \rightarrow \mathbb{Q}$ be an arbitrary function on the set \mathbb{P} of all partitions. Motivated by the formula (6) giving the generating function for counting covers without unramified components, we associate to f the formal power series

$$\langle f \rangle_q = \frac{\sum_{\lambda \in \mathbb{P}} f(\lambda) q^{|\lambda|}}{\sum_{\lambda \in \mathbb{P}} q^{|\lambda|}} \in \mathbb{Q}[[q]], \tag{20}$$

which we will call the *q-bracket*. In the previous section, the argument was a product of functions $f_\mu(\cdot)$ introduced in (8) and we recall here an algebra of functions on which *q*-brackets behave nicely, as well as two generating sets for this algebra.

The *algebra of shifted symmetric polynomials* is defined as $\Lambda^* = \varprojlim \Lambda^*(n)$, where $\Lambda^*(n)$ is the algebra of symmetric polynomials in the n variables $\lambda_1 - 1, \dots, \lambda_n - n$. The projective limit is taken with respect to the homomorphisms setting the last variable equal to zero. One of several ways to present a partition is to list the part lengths decreasingly, i.e. a partition is given by $\lambda = (\lambda_1, \lambda_2, \dots)$ with $\lambda_1 \geq \lambda_2 \geq \dots$ and $\sum_{i=1}^\infty \lambda_i = |\lambda|$. With this notation, the functions

$$P_\ell(\lambda) = \sum_{i=1}^\infty ((\lambda_i - i + 1/2)^\ell - (-i + 1/2)^\ell) \quad \text{and} \quad P_\mu = \prod_i P_{\mu_i} \tag{21}$$

obviously belong to the algebra of symmetric polynomials. It is also convenient to add constant terms to these functions, corresponding to the regularization of the infinite sum, and we let

$$p_\ell(\lambda) = P_\ell(\lambda) + (1 - 2^{-\ell})\zeta(-\ell). \tag{22}$$

The name ‘completed cycles’ refers to the functions P_ℓ/ℓ for the cycles (ℓ) : they ‘complete’ the functions f_ℓ defined in (8).

The following result summarizes the main properties of shifted symmetric polynomials we need. It is a combination of a theorem of Okounkov and Olshanski [OO97] and a theorem of Kerov and Olshanski.

Theorem 3.1 ([KO94]). *The algebra Λ^* is freely generated by all the p_ℓ (or equivalently by the P_ℓ) with $\ell \geq 1$. The functions f_μ defined in (8) belong to Λ^* . More precisely, as μ ranges over all partitions, the functions f_μ form a basis of Λ^* .*

To pass from the P_ℓ to the f_μ , note that $f_1 = P_1$ and $f_2 = P_2/2$, and more generally f_ℓ starts with P_ℓ/ℓ , for example

$$\begin{aligned} f_3 &= \frac{1}{3}P_3 - \frac{1}{2}P_1^2 + \frac{5}{12}P_1, & f_4 &= \frac{1}{4}P_4 - P_1P_2 + \frac{11}{8}P_2 \\ f_5 &= \frac{1}{5}P_5 - P_3P_1 - \frac{1}{2}P_2^2 + \frac{5}{6}P_1^3 - \frac{15}{4}P_1^2 + \frac{19}{6}P_3 + \frac{189}{80}P_1. \end{aligned} \quad (23)$$

We refer to [OP06, Section 3.3] or [Las08] for the conversion formulas in general.

At this stage we mention the following important result of Bloch–Okounkov and refer to Section 5.1 for the definition of quasimodular forms. Using Theorem 3.1 one provides the algebra Λ^* with a weight grading by assigning p_ℓ the weight $k = \ell + 1$.

Theorem 3.2 ([BO00]). *If f is a shifted symmetric function of weight k , then $\langle f \rangle_q$ is a quasimodular form of weight k .*

There is a long list of quite different proofs of this theorem. Already [BO00] contains two proofs, one in the spirit of [KZ95] and one with an explicit formula using determinants of theta derivatives. A proof based on vertex operators is given in [Mil03]. Zagier [Zag16] gave a very short proof, which also provided an efficient recursive method for computing q -brackets.

In this paper we will not use the Bloch–Okounkov theorem, but rather give yet another proof, by counting graphs with weights, at the end of Section 6. This proof is not our main objective and the proof is rather roundabout, but it shows that a lot of quasimodularity results can be ultimately traced back to Theorem 5.8.

4. Hurwitz numbers and graph sums

The first part of the section is purely expository and we recall some known (piecewise) polynomiality properties of the cardinalities of the sets of Hurwitz numbers introduced in (12) and their completed cycle variants. Then we combine the definition of triple Hurwitz numbers with the composition of torus covers into global graphs and local surfaces to obtain a formula for counting torus covers in terms of a graph count of triple Hurwitz numbers.

4.1. Triple Hurwitz numbers with completed cycles

In general, generalized double Hurwitz numbers with completed cycles are only piecewise polynomials in variables w_i^- and w_i^+ on the chambers defined by the walls where a partial sum of the w_i^- agrees with a partial sum of the w_i^+ . Recall that the shifted symmetric function f_ℓ satisfies $f_\ell = \frac{1}{\ell}P_\ell + \dots$. The formal *triple Hurwitz number* with

completed cycles

$$\overline{A}(\mathbf{w}^-, \mathbf{w}^+, \mu) = \frac{1}{\prod_i w_i^- \prod_i w_i^+} \sum_{|\lambda|=d} \chi_{\mathbf{w}^-}^\lambda \chi_{\mathbf{w}^+}^\lambda \frac{P_\mu(\lambda)}{\prod \mu_i} \tag{24}$$

obtained by replacing f_μ by the completed cycles $P_\mu/\prod \mu_i$ has much better properties, e.g. it is a polynomial outside the walls if $\mu = (\mu_1)$ is a partition consisting of a single cycle. To remove the jumps on the walls we introduce the *triple Hurwitz number with completed cycles and without unramified components*

$$\overline{A}'(\mathbf{w}^-, \mathbf{w}^+, \mu) = \sum_{\substack{\mathbf{u}^+ \subset \mathbf{w}^+, \mathbf{u}^- \subset \mathbf{w}^- \\ |\mu| \leq |\mathbf{u}^-| = |\mathbf{u}^+|}} M(\mathbf{u}^+, \mathbf{u}^-, \mathbf{w}^+, \mathbf{w}^-) \overline{A}(\mathbf{u}^-, \mathbf{u}^+, \mu) \tag{25}$$

by applying the same inclusion-exclusion inversion to \overline{A} as we did in (17) for A . The main reason to introduce completed cycles here is the following polynomiality result when μ is a cycle and triple Hurwitz numbers are in fact generalized double Hurwitz numbers. We learned about this from draft notes of Okounkov. It can be deduced from results of Shadrin, Spitz and Zvonkine [SSZ12].

Theorem 4.1. *If $\mu_1 + 1 - \ell(\mathbf{w}^-) - \ell(\mathbf{w}^+)$ is even, then the triple Hurwitz number $\overline{A}'(\mathbf{w}^-, \mathbf{w}^+, (\mu_1))$ with completed cycles and without unramified components for the last argument $\mu = (\mu_1)$ being a partition consisting of a single part is an even polynomial in the variables w_i^- and w_i^+ .*

If $\mu_1 + 1 - \ell(\mathbf{w}^-) - \ell(\mathbf{w}^+)$ is odd, then $\overline{A}'(\mathbf{w}^-, \mathbf{w}^+, (\mu_1)) = 0$.

Proof. The completed generalized double Hurwitz numbers are piecewise polynomial functions for any number of ramification points besides the two prescribed ones, but the polynomiality is global for one ramification point, as we now explain in detail.

Fix $m = \ell(\mathbf{w}^-)$ and $n = \ell(\mathbf{w}^+)$. We consider the vector space $V = \{(\mathbf{w}^-, \mathbf{w}^+); |\mathbf{w}^-| = |\mathbf{w}^+|\}$ and for $I \subset \{1, \dots, m\}$ and $J \subset \{1, \dots, n\}$ we define the hyperplane

$$W_{I,J} = \{(\mathbf{w}^-, \mathbf{w}^+) \in V; |\mathbf{w}_I^-| - |\mathbf{w}_J^+| = 0\}.$$

The sets $W_{I,J}$ are the walls of a hyperplane arrangement. In the interior of the chambers, the connected and disconnected Hurwitz numbers obviously coincide. For a chamber c of this arrangement, Theorem 6.4 of [SSZ12] shows that $\overline{A}(\mathbf{w}^-, \mathbf{w}^+, (\mu_1))|_c$ is a homogeneous polynomial of degree $\mu_1 + 1 - \ell(\mathbf{w}^-) - \ell(\mathbf{w}^+)$.

The wall crossing formula [SSZ12, Theorem 6.6] for two adjacent chambers c_1 and c_2 of the wall $W_{I,J}$ can be written in the case of the last argument $\mu = (\mu_1)$ being a partition consisting of a single part as

$$\begin{aligned} \overline{A}'(\mathbf{w}^-, \mathbf{w}^+, (\mu_1))|_{c_1} - \overline{A}'(\mathbf{w}^-, \mathbf{w}^+, (\mu_1))|_{c_2} \\ = \delta^2 (\overline{A}'(\mathbf{w}_I^-, \mathbf{w}_J^+ + \delta, (\mu_1)) \overline{A}'(\mathbf{w}_{I^c}^- + \delta, \mathbf{w}_{J^c}^+, \emptyset) \\ + \overline{A}'(\mathbf{w}_{I^c}^- + \delta, \mathbf{w}_{J^c}^+, (\mu_1)) \overline{A}'(\mathbf{w}_I^-, \mathbf{w}_J^+ + \delta, \emptyset)), \end{aligned}$$

where $\delta = |\mathbf{w}^-| - |\mathbf{w}^+|$. In fact, [SSZ12] states this formula in terms of \overline{A} instead of \overline{A}' , but for $\delta = 0$ the formula holds trivially by (25), and outside the walls the covers have no

unramified component. In this expression the terms with no ramification vanish since \overline{A}' denotes covers without unramified components. This implies that the polynomials are the same in any two adjacent chambers and hence the expression is globally polynomial.

Moreover, Theorem 6.4 of [SSZ12] implies that the polynomial $\overline{A}'(\mathbf{w}^-, \mathbf{w}^+, (\mu_1))$ has the same parity as $\mu_1 + 1 - \ell(\mathbf{w}^-) - \ell(\mathbf{w}^+)$. It remains to show that the polynomial vanishes when this expression is odd. The triple Hurwitz number without completed cycles $A'(\mathbf{w}^-, \mathbf{w}^+, (\mu_1))$ vanishes for $\mu_1 + 1 - \ell(\mathbf{w}^-) - \ell(\mathbf{w}^+)$ odd by the Riemann–Hurwitz formula and the same statement holds for f_{μ_1} replaced by any f_μ with $\text{wt}(\mu)$ odd. Since any p_μ of odd (resp. even) weight is a linear combination of f_μ of odd (resp. even) weight (see [OP06, (0.22)] for the general statement), the claim follows. \square

Later we will need to allow more general functions on partitions, and hence for any function F on partitions we define

$$A(\mathbf{w}^-, \mathbf{w}^+, F) = \frac{1}{\prod_i w_i^- \prod_i w_i^+} \sum_{|\lambda|=d} \chi_{\mathbf{w}^-}^\lambda \chi_{\mathbf{w}^+}^\lambda F(\lambda) \tag{26}$$

and we define $A'(\mathbf{w}^-, \mathbf{w}^+, F)$ in terms of $A(\mathbf{w}^-, \mathbf{w}^+, F)$ as in (25). In this notation we retrieve the previous definition of triple Hurwitz numbers as

$$A'(\mathbf{w}^-, \mathbf{w}^+, \mu) = A'(\mathbf{w}^-, \mathbf{w}^+, f_\mu) \quad \text{and} \quad \overline{A}'(\mathbf{w}^-, \mathbf{w}^+, \mu) = A'(\mathbf{w}^-, \mathbf{w}^+, P_\mu / \prod \mu_i).$$

4.2. Graph sums with triple Hurwitz numbers

The first goal here is to use Propositions 2.4 and 2.5 to write the generating series $N'(\Pi)$ for counting torus covers without unramified components in terms of graph sums involving triple Hurwitz numbers without unramified components. First of all, we can decompose $N'(\Pi)$ according to the contributions of individual graphs, i.e.

$$N'(\Pi) = \sum_{\Gamma} \frac{1}{|\text{Aut}(\Gamma)|} N'(\Gamma, \Pi),$$

where the sum is over all (not necessarily connected) labelled graphs Γ with $n = |\Pi|$ vertices and where $\text{Aut}(\Gamma)$ are the automorphisms of the graph Γ that respect the vertex labelling. (Note that Γ has neither a labelling nor an orientation on the edges.)

Proposition 4.2. *The contributions of individual labelled graphs to $N'(\Pi)$ can be expressed in terms of triple Hurwitz numbers as*

$$N'(\Gamma, \Pi) = \sum_{G \in \Gamma} N'(G, \Pi), \tag{27}$$

where

$$N'(G, \Pi) = \sum_{\substack{h \in \tilde{\mathbb{N}}^{E(G)}, \\ w \in \mathbb{Z}_+^{E(G)}}} \prod_{e \in E(G)} w_e q^{h_e w_e} \prod_{v \in V(G)} A'(\mathbf{w}_v^-, \mathbf{w}_v^+, \mu_v) \delta(v) \tag{28}$$

and

$$\delta(v) = \delta\left(\sum_{i \in e_+(v)} w_i^+ - \sum_{i \in e_-(v)} w_i^-\right). \tag{29}$$

The delta-function factor is redundant in this expression by our definition of $A'(\mathbf{w}_v^-, \mathbf{w}_v^+, \mu_v)$, but keeping it will be important once we pass from A' to a polynomial expression.

Proof of Proposition 4.2. This is a direct consequence of the correspondence in Proposition 2.4. The degree of the covering is encoded in the (w_e, h_e) by (19) and the factor w_e accounts for the number of possible twists (values of t_e) for any given edge e . \square

The strategy to prove quasimodularity is to reduce to ‘expressions as in (27) and (28)’ but with \bar{A}' as argument, which is polynomial by Theorem 4.1. To formalize this, recall from (6) and (20) that the counting function $N'(\Pi)$ is a q -bracket of a shifted symmetric function. By Theorem 3.1 it hence suffices to treat q -brackets of products of the p_ℓ .

Theorem 4.3. *The q -bracket of any shifted symmetric function can be expressed as*

$$\langle p_{\ell_1} \cdots p_{\ell_n} \rangle_q = \sum_{\Gamma} \sum_{G \in \Gamma} \langle p_{\ell_1} \cdots p_{\ell_n} \rangle_{q,G} \tag{30}$$

where the sum runs over graphs with n labelled vertices and all orientations G of Γ , and

$$\langle p_{\ell_1} \cdots p_{\ell_n} \rangle_{q,G} = \sum_{\substack{h \in \tilde{\mathbb{N}}^{E(G)} \\ w \in \mathbb{Z}_+^{E(G)}}} \prod_{e \in E(G)} w_e q^{h_e w_e} \prod_{v \in V(G)} \bar{A}'(\mathbf{w}_v^-, \mathbf{w}_v^+, (\ell_{\#v})) \delta(v). \tag{31}$$

Here $\#v$ denotes the label of the vertex v .

Proof. Our strategy is to reduce this to the cases covered by Proposition 4.2. For this purpose, we define for any function F on partitions the auxiliary brackets

$$[F_1, \dots, F_n] = \sum_{\Gamma} [F_1, \dots, F_n]_{\Gamma}, \quad [F_1, \dots, F_n]_{\Gamma} = \sum_{G \in \Gamma} [F_1, \dots, F_n]_G \tag{32}$$

where the sum is over all labelled graphs Γ with n vertices and over all the orientations, respectively, and where

$$[F_1, \dots, F_n]_G = \sum_{\substack{h \in \tilde{\mathbb{N}}^{E(G)} \\ w \in \mathbb{Z}_+^{E(G)}}} \prod_{i \in E(G)} w_i q^{h_i w_i} \prod_{v \in V(G)} A'(w_v^-, w_v^+, F_{\#v}) \delta(v). \tag{33}$$

In this notation, we want to show that

$$\langle p_{\ell_1} \cdots p_{\ell_n} \rangle_q = [p_{\ell_1}, \dots, p_{\ell_n}]. \tag{34}$$

On the other hand, Proposition 4.2 can be restated in this notation as

$$\langle f_{\mu_1} \cdots f_{\mu_n} \rangle_q = [f_{\mu_1}, \dots, f_{\mu_n}]. \tag{35}$$

We can express by Theorem 3.1 each of the generators p_ℓ of Λ^* as $p_\ell = \sum_{\mu} c_{\ell,\mu} f_\mu$ for some coefficients $c_{\ell,\mu}$. Obviously, a q -bracket of a product of n shifted symmetric functions is multilinear in the n arguments. On the other hand, the brackets in (32) are multilinear as well, since the arguments of the brackets appear only linearly as arguments of A' . Consequently, (34) is a linear combination of equations of the form (35). \square

5. Constant coefficients of quasi-elliptic functions

5.1. Quasimodular forms

Kaneko and Zagier [KZ95] introduced quasimodular forms in connection with counting simply branched covers of the torus.

A *quasimodular form* for a cofinite Fuchsian group $\Gamma \subset \text{SL}(2, \mathbb{R})$ of weight k is a function $f : \mathbb{H} \rightarrow \mathbb{C}$ that is holomorphic on \mathbb{H} and at the cusps of Γ and such that there exists an integer p and holomorphic functions $f_i : \mathbb{H} \rightarrow \mathbb{C}$ such that

$$(c\tau + d)^{-k} f\left(\frac{a\tau + b}{c\tau + d}\right) = \sum_{i=0}^p f_i(\tau) \left(\frac{c}{c\tau + d}\right)^i$$

for all $\begin{pmatrix} a & b \\ c & d \end{pmatrix} \in \Gamma$.

Note that this definition implies (take the identity matrix) that $f_0 = f$. The smallest integer p with the above property is called the *depth* of the quasimodular form. By definition, quasimodular forms of depth zero are simply modular forms. The basic examples of quasimodular forms are the Eisenstein series defined by

$$G_{2k}(\tau) = \frac{(2k-1)!}{2(2\pi i)^{2k}} \sum_{(m,n) \in \mathbb{Z}^2 \setminus \{(0,0)\}} \frac{1}{(m+n\tau)^{2k}} = -\frac{B_{2k}}{4k} + \sum_{n=1}^{\infty} \sigma_{2k-1}(n)q^n.$$

Here B_l is the Bernoulli number, σ_l is the divisor sum function and $q = e^{2\pi i \tau}$. For $k \geq 2$ these are modular forms, while for $k = 2$ the Eisenstein series

$$G_2(\tau) = -\frac{1}{24} + \sum_{n=1}^{\infty} \sigma_1(n)q^n$$

is a quasimodular form of weight 2 and depth 1 for $\text{SL}(2, \mathbb{Z})$. Note that the q -expansion makes sense as a definition for G_{2k+1} but does not give a quasimodular form. We will encounter this power series in Section 9.

In terms of Eisenstein series, we recall a characterization of quasimodular forms that might serve as an alternative definition of that ring for the special case of the modular group.

Proposition 5.1 ([KZ95]). *The ring of quasimodular forms for $\Gamma = \text{SL}(2, \mathbb{Z})$ is equal to $\mathbb{C}[E_2, E_4, E_6]$, the polynomial ring over \mathbb{C} generated by the first three Eisenstein series. This ring is stable under the q -derivative $D_q = q \frac{\partial}{\partial q} = \frac{1}{2\pi i} \frac{\partial}{\partial \tau}$. More precisely, the q -derivative of a quasimodular form of weight k is a quasimodular form of weight $k + 2$.*

5.2. Coefficients of a two-variable Jacobi form

The main player of this section is a function $F_\tau(u, v)$ in two ‘Jacobi’ variables u, v that was used by Zagier [Zag91] in connection with periods of modular forms. For its defini-

tion we use the genus 1 Jacobi theta function

$$\theta(u) = \theta(u; \tau) = \sum_{n \in \mathbb{Z}} (-1)^n q^{\frac{1}{2}(n+1/2)^2} e^{(n+1/2)u}.$$

We then let

$$F_\tau(u, v) = \frac{\theta(u+v)\theta'(0)}{\theta(u)\theta(v)}$$

where we denote by prime the u -derivative $f'(u) = \frac{\partial f}{\partial u}$. The main feature of F_τ is that we know both its Fourier expansion, which we will connect to the counting functions we are interested in, and the Laurent expansion, which is the main tool to prove quasimodularity statements.

Theorem 5.2 ([Zag91, Theorem 3.1]). *The Fourier development of $F_\tau(u, v)$ is*

$$F_\tau(u, v) = \frac{1}{2} \left(\coth \frac{u}{2} + \coth \frac{v}{2} \right) - 2 \sum_{n=1}^{\infty} \left(\sum_{d|n} \sinh \left(du + \frac{n}{d}v \right) \right) q^n. \tag{36}$$

Its Laurent series expansion is

$$F_\tau(u, v) = \frac{1}{u} + \frac{1}{v} - 2 \sum_{r,s=0}^{\infty} D_q^{\min(r,s)} G_{|r-s|+1}(\tau) \frac{u^r}{r!} \frac{v^s}{s!}. \tag{37}$$

The function $F_\tau(u, v)$ has the elliptic transformation property

$$F_\tau(u + 2\pi i(n\tau + s), v + 2\pi i(m\tau + r)) = q^{-mn} \zeta^{-m} \eta^{-n} F_\tau(u, v) \tag{38}$$

for all $m, n, r, s \in \mathbb{Z}$, where $\zeta = e^u$ and $\eta = e^v$, and the modular transformation property

$$F_{\frac{a\tau+b}{c\tau+d}} \left(\frac{u}{c\tau+d}, \frac{v}{c\tau+d} \right) = (c\tau+d) e^{\frac{cuv/2\pi i}{c\tau+d}} F_\tau(u, v) \tag{39}$$

for all $\begin{pmatrix} a & b \\ c & d \end{pmatrix} \in \text{SL}(2, \mathbb{Z})$.

We will use three functions derived from coefficients of $F_\tau(u, v)$, namely

$$Z(z) = -[v^0]F_\tau(u, v), \quad P(z) = Z'(z), \quad L(z) = -[v^1]F_\tau(u, v) + \frac{1}{12} \tag{40}$$

where $u = 2\pi iz$. The first one, $Z(z) = -\frac{\theta'(2\pi iz)}{2\pi i\theta(2\pi iz)} = -\frac{\zeta(z)}{2\pi i} + 2G_2 2\pi iz$, is the classical Weierstraß ζ -function up to normalization and an additive term, and the second is $P(z) = \frac{1}{(2\pi i)^2} \wp(z) + 2G_2$, the Weierstraß \wp -function up to normalization and an additive term. The last one has no classical name but it is the function that makes the extension to Siegel–Veech weighted counting work. As a direct consequence of Theorem 5.2 we have

the Fourier developments in the domain $|q| < |\zeta| < 1$

$$\begin{aligned} Z(z) &= \frac{1}{2} + \sum_{k \geq 1} \left(\zeta^k + \sum_{n \geq 1} q^{nk} (\zeta^k - \zeta^{-k}) \right), \\ P(z) &= \sum_{k \geq 1} \left(k \zeta^k + \sum_{n \geq 1} k q^{nk} (\zeta^k + \zeta^{-k}) \right), \\ L(z) &= \sum_{k \geq 1, n \geq 1} n q^{nk} (\zeta^k + \zeta^{-k}), \end{aligned} \tag{41}$$

and the Laurent series developments

$$\begin{aligned} Z(z) &= -\frac{1}{u} + 2 \sum_{k=0}^{\infty} \frac{G_{2k+2}}{(2k+1)!} u^{2k+1}, \\ P(z) &= \frac{1}{u^2} + 2 \sum_{k=0}^{\infty} \frac{G_{2k+2}}{(2k)!} u^{2k}, \\ L(z) &= 2G_2 + \frac{1}{12} + 2 \sum_{k=1}^{\infty} \frac{D_q G_{2k}}{(2k)!} u^{2k}, \end{aligned} \tag{42}$$

of our special functions.

We refer to the shift P of the Weierstraß \wp -function as the *propagator*. (This terminology is used in e.g. [Dij95], [BBBM17]. It goes back to [BCOV94] and the function P is hence also called the BCOV-propagator in e.g. [Li12].)

5.3. Quasimodular forms as constant coefficients of quasi-elliptic functions

We proceed with our main criterion for quasimodularity, involving the constant coefficients of products of the functions Z , P and L introduced above, and their derivatives. We start with a general remark on the domains where the expansions are valid. Suppose that the meromorphic function $f(z_1, \dots, z_n; \tau)$ is periodic under $z_j \mapsto z_j + 1$ for each j and under $\tau \mapsto \tau + 1$. We can then write $f(z_1, \dots, z_n; \tau) = \bar{f}(\zeta_1, \dots, \zeta_n, q)$ where $\zeta_j = e^{2\pi i z_j}$ as above. For any permutation $\pi \in S_n$ we fix the domain

$$\Omega_\pi = \{ |q \zeta_{\pi(i+1)}| < |\zeta_{\pi(i)}| < |\zeta_{\pi(i+1)}| < 1 \text{ for all } i = 1, \dots, n-1 \}. \tag{43}$$

On such a domain the *constant term with respect to all the ζ_i* is well-defined. It can be expressed as the integral

$$[\zeta_n^0 \dots \zeta_1^0]_\pi \bar{f} = \frac{1}{(2\pi i)^n} \oint_{\gamma_n} \dots \oint_{\gamma_1} f(z_1, \dots, z_n; \tau) dz_1 \dots dz_n$$

along the integration paths

$$\gamma_j : [0, 1] \rightarrow \mathbb{C}, \quad t \mapsto iy_j + t,$$

where $0 \leq y_{\pi(1)} < \dots < y_{\pi(n)} < 1$. We call these our *standard integration paths* for the permutation π . If the domain Ω_π is clear from the context we also write $[\zeta^0]$ or $[\zeta_n^0 \dots \zeta_1^0]$ as shorthand for the coefficient extraction $[\zeta_n^0 \dots \zeta_1^0]_\pi$.

Our aim here is to show Theorem 5.8 stating that for a large class of functions that are quasimodular and quasi-elliptic in (z_1, \dots, z_n) (in a sense made precise below) the constant term with respect to the ζ_i is a quasimodular form.

We start with a preliminary definition of a ring of multivariable Jacobi forms. For $n \geq 0$ we let $\mathcal{J}_n^{(k)}$ be the vector space of meromorphic functions f on $\mathbb{C}^n \times \mathbb{H}$ in the variables $(z_1, \dots, z_n; \tau)$ that

- (i) have poles on \mathbb{C}^n at most at the $\mathbb{Z} + \tau\mathbb{Z}$ -translates of the diagonals $z_i - z_j$,
- (ii) are elliptic with respect to the lattice $\mathbb{Z} + \tau\mathbb{Z}$ in the variables z_i for $i = 1, \dots, n$, and
- (iii) are quasimodular of weight k for $\text{SL}(2, \mathbb{Z})$, i.e. f is holomorphic in τ on $\mathbb{H} \cup \infty$ and there exists some $p \geq 0$ (called *depth*) and functions $f_i(z_1, \dots, z_n; \tau)$ that are holomorphic in τ and meromorphic in each z_i such that

$$(c\tau + d)^{-k} f\left(\frac{z_1}{c\tau + d}, \dots, \frac{z_n}{c\tau + d}; \frac{a\tau + b}{c\tau + d}\right) = \sum_{i=0}^p f_i(z_1, \dots, z_n; \tau) \left(\frac{c}{c\tau + d}\right)^i$$

for all $\begin{pmatrix} a & b \\ c & d \end{pmatrix} \in \text{SL}(2, \mathbb{Z})$.

Again, taking the identity matrix in this definition implies that $f_0 = f$.

Proposition 5.3. *The direct sum*

$$\mathcal{J}_n = \bigoplus_{k \geq 0} \mathcal{J}_n^{(k)}$$

is a graded ring. The derivatives $\partial/\partial z_i$ map $\mathcal{J}_n^{(k)}$ to $\mathcal{J}_n^{(k+1)}$ for all $i = 1, \dots, n$ and the derivative $D_q = q \frac{\partial}{\partial q}$ maps $\mathcal{J}_n^{(k)}$ to $\mathcal{J}_n^{(k+2)}$.

The m -th derivative $P^{(m)}(z_i - z_j)$ of the propagator lies in $\mathcal{J}_n^{(m+2)}$. Moreover, $Z_{ijn} = Z(z_n - z_i) + Z(z_j - z_n) + Z(z_i - z_j)$ lies in $\mathcal{J}_n^{(1)}$.

Proof. The first two statements obviously follow from the definition and differentiation of the quasimodular transformation property. For the third statement all but the quasimodularity are well-known (and follow also from Theorem 5.2). The quasimodular transformation property (iii) follows from (39) by using $P_1(z_1, \dots, z_n; \tau) = 1$ and $P_0 = P$. For the last statement, the ellipticity of Z_{ijn} follows from the properties

$$Z(z + 1) = Z(z) \quad \text{and} \quad Z(z + \tau) = Z(z) + 1$$

of the individual summands. Equation (39) again implies that $Z(z_i - z_j)$ is quasimodular (in the sense of (iii)) of weight 1 and depth 1 with $Z_i(z_i - z_j) = z_i - z_j$. This in turn implies that Z_{ijn} is even quasimodular of weight 1 and depth 0, i.e. modular. \square

Proposition 5.4. *For $n = 0$ and $n = 1$ the ring \mathcal{J}_n consists only of quasimodular forms in τ .*

For $n \geq 2$ the ring \mathcal{J}_n is generated as a \mathcal{J}_{n-1} -module by the derivatives of the P -function, $P_j^{(m)} = P^{(m)}(z_n - z_j)$ for all $m \geq 0$ and all $j = 1, \dots, n - 1$, and by the linear combinations $Z_{ijn} = Z(z_n - z_i) + Z(z_j - z_n) + Z(z_i - z_j)$ for all $1 \leq i < j \leq n - 1$.

More precisely, if $f \in \mathcal{J}_n^{(k)}$ then we can write

$$f = \sum a_{m,j} P_j^{(m)} + \sum b_{i,j} Z_{ijn} + c$$

with $a_{m,j} \in \mathcal{J}_{n-1}^{(k-m-2)}$, $b_{i,j} \in \mathcal{J}_{n-1}^{(k-1)}$ and $c \in \mathcal{J}_{n-1}^{(k)}$.

Proof. For the first statement we simply note that an elliptic function without poles is constant. For the second statement we argue by induction on the pole orders and we may assume that f is homogeneous of weight k . Suppose that f has a pole of order m exactly at $z_n - z_j$. Then the limit

$$f^{[j]}(z_1, \dots, z_{n-1}) = \lim_{\varepsilon \rightarrow 0} \varepsilon^m f(z_1, \dots, z_j, \dots, z_{n-1}, z_j + \varepsilon)$$

exists and is non-zero. We claim that $f^{[j]} \in \mathcal{J}_{n-1}^{(k-m)}$. Conditions (i) and (ii) are obvious from the definition. If f_i denotes a component of f in the modular transformation (iii), we define $f_i^{[j]}(z_1, \dots, z_{n-1})$ as above for $f = f_0$. This transformation implies

$$\begin{aligned} (c\tau + d)^{-k+m} \left(\frac{\varepsilon}{c\tau + d}\right)^m f\left(\frac{z_1}{c\tau + d}, \dots, \frac{z_{n-1}}{c\tau + d}, \frac{z_j + \varepsilon}{c\tau + d}, \frac{a\tau + b}{c\tau + d}\right) \\ = \varepsilon^m \sum_{i=0}^d f_i(z_1, \dots, z_{n-1}, z_j + \varepsilon; \tau) \left(\frac{c}{c\tau + d}\right)^i, \end{aligned} \quad (44)$$

and taking the limit $\varepsilon \rightarrow 0$ gives the quasimodularity of $f^{[j]}$.

If $m \geq 2$ then replacing f by $f - f^{[j]} P_j^{(m-2)} (-2\pi i)^m / (m-1)!$ decreases the pole order along $z_n = z_j$ and does not increase the pole order along any of the divisors $z_n = z_i$ for $i \geq 2$.

Inductively we may thus suppose that f has at most simple poles along all the divisors $z_n - z_j$. The residue theorem (for f considered as a function of z_n) implies that $\sum_{j=1}^{n-1} f^{[j]} = 0$. Consequently,

$$g = f - \sum_{j=2}^{n-1} \left(\sum_{i=1}^{j-1} f^{[i]}\right) Z_{j-1,j,n}$$

is still elliptic and has no poles (considered as a function of z_n). This implies $g \in \mathcal{J}_{n-1}^{(k)}$ and completes the inductive argument. \square

One is tempted to deduce from this that if $f \in \mathcal{J}_n^k$ then for any permutation π the constant term on Ω_π is a quasimodular form of pure weight k . This, however, is *not true!* In general, those constant terms are of mixed weight $\leq k$, as we will see in the example in Section 5.4. Even if one is only interested in computing the constant terms of elements in the ring $\mathcal{J}_n^{(k)}$, the fact that

$$[\zeta_n^0] P^{(m)}(z_n - z_j) = 0 \quad (m \geq 0) \quad (45)$$

but $[\zeta_n^0] Z_{ijn} = Z(z_i - z_j)$ is no longer elliptic forces the consideration of the following more general case of quasi-elliptic functions.

Let $\Delta = \Delta_\tau$ be the operator on meromorphic functions defined by

$$\Delta(f)(z) = f(z + \tau) - f(z).$$

A meromorphic function f is called *quasi-elliptic* if $f(z + 1) = f(z)$ and there exists some positive integer e such that $\Delta^e(f)$ is elliptic. The minimal such e is called the *order (of quasi-ellipticity)* of f .

We say that a meromorphic function $f : \mathbb{C}^n \times \mathbb{H} \rightarrow \mathbb{C}$ is quasi-elliptic if it is quasi-elliptic in each of the first n variables. For such a function we write $\mathbf{e} = (e_1, \dots, e_n)$ for the tuple of orders of quasi-ellipticity in the n variables. Consequently, a quasi-elliptic function of order $(0, \dots, 0)$ is simply an elliptic function.

We write Δ_i for the operator Δ acting on the i -th variable. Note that these operators Δ_i commute. We now state the appropriate generalization of the definition of $\mathcal{J}_n^{(k)}$ above.

Definition 5.5. For $n, k \geq 0$ and $\mathbf{e} \geq 0$ we define the vector space $\mathcal{Q}_{n,\mathbf{e}}^{(k)}$ of *quasi-elliptic quasimodular forms* to be the space of meromorphic functions f on $\mathbb{C}^n \times \mathbb{H}$ in the variables $(z_1, \dots, z_n; \tau)$ that

- (i) have poles on \mathbb{C}^n at most at the $\mathbb{Z} + \tau\mathbb{Z}$ - translates of the diagonals $z_i - z_j$,
- (ii) are quasi-elliptic of order \mathbf{e} , and
- (iii) are quasimodular of weight k for $\mathrm{SL}(2, \mathbb{Z})$, i.e. f is holomorphic in τ on $\mathbb{H} \cup \infty$ and there exists some $p \geq 0$ (called *depth*) and functions $f_i(z_1, \dots, z_n; \tau)$ that are holomorphic in τ and meromorphic in each z_i such that

$$(c\tau + d)^{-k} f\left(\frac{z_1}{c\tau + d}, \dots, \frac{z_n}{c\tau + d}; \frac{a\tau + b}{c\tau + d}\right) = \sum_{i=0}^p f_i(z_1, \dots, z_n; \tau) \left(\frac{c}{c\tau + d}\right)^i$$

for all $\begin{pmatrix} a & b \\ c & d \end{pmatrix} \in \mathrm{SL}(2, \mathbb{Z})$.

We remark that, in contrast to the case of (usual) quasimodular forms, the functions f_i do not need to belong to any of the spaces $\mathcal{Q}_{n,\mathbf{e}}^{(k)}$.³

Proposition 5.6. *The direct sum*

$$\mathcal{Q}_n = \bigoplus_{k \geq 0} \mathcal{Q}_n^{(k)}, \quad \text{where} \quad \mathcal{Q}_n^{(k)} = \bigoplus_{\mathbf{e} \geq 0} \mathcal{Q}_{n,\mathbf{e}}^{(k)},$$

is a graded ring. The derivatives $\partial/\partial z_i$ map $\mathcal{Q}_n^{(k)}$ to $\mathcal{Q}_n^{(k+1)}$ for all $i = 1, \dots, n$, and the derivative $D_q = q \frac{\partial}{\partial q}$ maps $\mathcal{Q}_n^{(k)}$ to $\mathcal{Q}_n^{(k+2)}$.

³ For example, already for $Z(z_i - z_j)$ we have seen $Z_1 = z_i - z_j$, which is not 1-periodic. Our definition that imposes 1-periodicity (and thus breaks the symmetry in the role of the $\mathbb{Z} + \tau\mathbb{Z}$ -lattice) is the reason for this. A more conceptual definition would be to consider functions that are annihilated by some power of both shift operators Δ_τ and Δ_1 with respect to every variable. E.g. the function $z_i - z_j$ has this property. Since we do not aim e.g. for an operation of $\mathfrak{sl}(2)$ on our ring of quasi-elliptic quasimodular forms, we will not discuss this generalization here.

For all $i, j \in \{1, \dots, n\}$ the functions

$$L(z_i - z_j) = -\frac{1}{2}Z^2(z_i - z_j) + \frac{1}{2}P(z_i - z_j) - G_2 + \frac{1}{12} \tag{46}$$

belong to $\mathcal{Q}_n^{(0)} \oplus \mathcal{Q}_n^{(2)}$.

Proof. For the proof that \mathcal{Q}_n is closed under multiplication we remark that $\Delta_i^m(fg)$ is a sum of products of $\Delta_i^{m_1}(f)$ and $\Delta_i^{m_2}(g)$ with $m_1 + m_2 = m$, evaluated at arguments translated by multiples of τ . Consequently, if $f \in \mathcal{Q}_{n, \mathbf{e}_1}^{(k_1)}$ and $g \in \mathcal{Q}_{n, \mathbf{e}_2}^{(k_2)}$, then $fg \in \mathcal{Q}_{n, \mathbf{e}_1 + \mathbf{e}_2}^{(k_1 + k_2)}$. The property of the derivatives can be checked as in the case of \mathcal{J}_n .

For the last identity we use the elliptic transformation law (38) to deduce that $L + Z^2/2$ is elliptic. The first terms of the Laurent series of this function are

$$L(z) + \frac{Z^2(z)}{2} = \frac{1}{2u^2} + \frac{1}{12} + O(z^2).$$

Consequently, $L + \frac{Z^2}{2} - (\frac{1}{2}P - G_2 + \frac{1}{12})$ is an elliptic function with no poles, i.e. it is constant with respect to z . Moreover this constant is the value at $z = 0$, which is 0. \square

Proposition 5.7. *The vector space \mathcal{Q}_n is (additively) generated as a \mathcal{Q}_{n-1} -module by the functions $Z^e(z_n - z_j)P^{(m)}(z_n - z_j)$ for $j = 1, \dots, n - 1$ and for all $e, m \geq 0$.*

More precisely, if $f \in \mathcal{Q}_n^{(k)}$ then we can write

$$f(z_1, \dots, z_n) = \sum_{e, m, j} a_{e, m, j} Z^e(z_n - z_j) P^{(m)}(z_n - z_j) + \sum_{e, j} b_{e, j} Z^e(z_n - z_j) + c$$

with $a_{e, m, j} \in \mathcal{Q}_{n-1}^{(k-e-m-2)}$, $b_{e, j} \in \mathcal{Q}_{n-1}^{(k-e)}$ and $c \in \mathcal{Q}_{n-1}^{(k)}$.

Proof. For every n we argue inductively on the order $e = \min_{j \geq 0} \{\Delta_n^j(f) \text{ elliptic}\}$ of quasi-ellipticity with respect to the last variable. Suppose, without loss of generality, that $f \in \mathcal{Q}_n^{(k)}$ is homogeneous of weight k . If $e = 0$ then we proceed as in the proof of Proposition 5.4 and subtract \mathcal{Q}_{n-1} -multiples of $P^{(m)}(z_n - z_j)$ for appropriate m and $j \in \{1, \dots, n - 1\}$ and finally \mathcal{Q}_{n-1} -multiples of $Z(z_n - z_j) - Z(z_n - z_k)$ so that the resulting function is elliptic and without poles in the variable z_n , hence constant in z_n .

Now consider the case $e > 0$. Using the induction hypothesis we can write

$$\Delta_n(f)(z_1, \dots, z_n) = \sum_{s=0}^{e-1} \sum_{j, m} (a_{s, j, m} Z^s(z_n - z_j) P^{(m)}(z_n - z_j) + b_{s, j} Z^s(z_n - z_j)).$$

Now set

$$\tilde{f}(z_1, \dots, z_n) = \sum_{s=0}^{e-1} \frac{1}{s+1} \sum_{j, m} (a_{s, j, m} Z^{s+1}(z_n - z_j) P^{(m)}(z_n - z_j) + b_{s, j} Z^{s+1}(z_n - z_j)).$$

Then, since

$$\Delta_n(Z^{s+1}(z_n) P^{(m)}(z_n)) = P^{(m)}(z_n) \sum_{t=0}^s \binom{s+1}{t} Z^t(z_n)$$

we conclude that

$$\Delta_n(f - \tilde{f})(z_1, \dots, z_n) = \sum_{s=0}^{e-1} \frac{1}{s+1} \left(\sum_{j,m} (a_{s,j,m} P^{(m)}(z_n - z_j) + b_{s,j}) \cdot \left(\sum_{t=0}^{s-1} \binom{s+1}{t} Z^t(z_n - z_j) \right) \right)$$

has order $\leq e - 2$ with respect to z_n . Consequently, $f - \tilde{f}$ has order $\leq e - 1$ and another application of the induction hypothesis implies the claim. \square

Using this additive basis we can now prove the main result, which contains Theorem 1.1 as a special case.

Theorem 5.8. *For any permutation π the constant term with respect to the domain Ω_π of a function in $\mathcal{Q}_n^{(k)}$ is a quasimodular form of mixed weight $\leq k$.*

Proof. By relabelling the variables of $f \in \mathcal{Q}_n^{(k)}$ we may assume that π is the trivial permutation. We may thus write f as in Proposition 5.7 and integrate with respect to z_n first. We are thus reduced to showing that the z_n -integrals of the additive generators $Z^e(z_n - z_j)P^{(m)}(z_n - z_j)$ and $Z^e(z_n - z_j)$ are quasimodular forms of mixed weight $\leq e + 2 + m$. For the generators including a P -derivative we use the integration by parts $[Z^e(z)]' = eZ^{e-1}(z)P(z)$ and

$$[Z^e(z)P^{(m-1)}(z)]' = eZ^{e-1}(z)P(z)P^{(m-1)}(z) + Z^e(z)P^{(m)}(z)$$

to reduce the order e until we can apply (45). This involves rewriting $P(z)P^{(m-1)}(z)$ as a linear combination of $P^{(j)}(z)$. To do this, we use again Proposition 5.4 and note that the terms Z_{ijn} will not occur in this case, since the expression $P(z)P^{(m-1)}(z)$ has a unique pole at $z = 0$ modulo $\mathbb{Z} + \tau\mathbb{Z}$, and hence zero residue there. The integrals of the remaining generators are dealt with in the next proposition. \square

In all the steps so far the weight of the quasimodular form has been preserved. We isolate the next step since this is the reason for mixed weight.

Proposition 5.9. *The constant coefficient $[\zeta^0]Z^e(z)$ is a quasimodular form of mixed weight at most e .*

Proof. Since $Z(z)$ is an odd function of z , we obtain, for ℓ odd,

$$\begin{aligned} \int_0^1 Z^\ell(z + i\varepsilon) dz &= \int_{-1/2}^{1/2} Z^\ell(z + i\varepsilon) dz = - \int_{-1/2}^{1/2} Z^\ell(z - i\varepsilon) dz \\ &= -\frac{1}{2} \text{Res}_0 Z^\ell \end{aligned} \tag{47}$$

and these residues can be read off from the Laurent series development (42) raised to the ℓ -th power.

On the other hand, we claim that $[\zeta^0](Z - 1/2)^\ell = 0$ for ℓ odd. To see this, we expand the product of the Fourier expansions (41) to obtain

$$(Z - 1/2)^\ell = \sum_{\substack{k_1, \dots, k_\ell \geq 1 \\ \varepsilon_1, \dots, \varepsilon_\ell \in \{\pm 1\}}} \prod_{i=1}^\ell \varepsilon_i \frac{Q_i(k_i, \varepsilon_i)}{1 - q^{k_i}} \zeta^{k_i \varepsilon_i}, \tag{48}$$

where $Q_i(k_i, \varepsilon_i) = 1$ for $\varepsilon = 1$ and $Q_i(k_i, \varepsilon_i) = q^{k_i}$ for $\varepsilon = -1$. The constant term $[\zeta^0](Z - 1/2)^\ell$ is equal to the sum over all k_i and ε_i with $\sum k_i \varepsilon_i = 0$ of the right hand side of (48). This set admits an involution by swapping the signs of all the ε_i . This involution changes the sign of the factor $\prod_{i=1}^\ell \varepsilon_i$ since ℓ is odd. We claim that the rest of the product is unchanged by the involution. The denominator obviously does not change. The numerator is q raised to the power $\sum_{i: \varepsilon_i = +1} k_i$ in one case and to the power $\sum_{i: \varepsilon_i = -1} k_i$ in the other case. The two sums are equal by the defining condition of the constant term.

Knowing the constant terms of $(Z - 1/2)^\ell$ and Z^ℓ for ℓ odd, we can solve the (triangular) system of linear equations to determine the constant coefficients of Z^ℓ for ℓ even. \square

The first few values of these constant coefficients of Z^ℓ are

$$\begin{aligned} [\zeta^0]Z &= \frac{1}{2}, & [\zeta^0]Z^2 &= -2G_2 + \frac{1}{6}, \\ [\zeta^0]Z^3 &= -3G_2, & [\zeta^0]Z^4 &= 8G_2^2 - \frac{1}{3}G_4 - 2G_2 - \frac{1}{30}, \\ [\zeta^0]Z^5 &= 20G_2^2 - \frac{5}{6}G_4, & [\zeta^0]Z^6 &= \frac{-1}{60}G_6 + 4G_4G_2 - 40G_2^3 + 20G_2^2 - \frac{5}{6}G_4 + G_2 + \frac{1}{42}. \end{aligned}$$

5.4. An example of mixed weight

Here we illustrate that the proof of Theorem 5.8 provides an effective algorithm by computing (with respect to the standard order (43)) the expression

$$\begin{aligned} &[\zeta^0]P(z_1 - z_2)^2 P(z_1 - z_4) P(z_2 - z_3) P(z_3 - z_4)^2 \\ &= 4q^2 + 224q^3 + 3088q^4 + 21888q^5 + 105136q^6 + 388288q^7 + 1197280q^8 + O(q^9) \\ &= -256G_2^6 + \frac{640}{3}G_4G_2^4 + \frac{112}{9}G_6G_2^3 - \frac{400}{9}G_4^2G_2^2 - \frac{140}{9}G_6G_4G_2 + \frac{2000}{81}G_4^3 + \frac{49}{108}G_6^2 \\ &\quad + \left(-\frac{256}{3}G_4G_2^3 - \frac{16}{5}G_6G_2^2 + \frac{320}{21}G_4^2G_2 + \frac{28}{9}G_6G_4\right), \end{aligned} \tag{49}$$

which is a quasimodular form of mixed weight 10 and 12.

To prove this formula we first treat the terms depending on z_4 and write

$$\begin{aligned} P(z_4 - z_1)^2 P(z_4 - z_3) &= \frac{1}{6}P(z_1 - z_3)P''(z_4 - z_1) + \frac{1}{2}P'(z_3 - z_1)P'(z_4 - z_1) \\ &\quad + \left(\frac{1}{2}P''(z_1 - z_3) + 4G_2P(z_1 - z_3)\right)P(z_4 - z_1) \\ &\quad + P(z_1 - z_3)^2 P(z_4 - z_3) \\ &\quad + \left(4G_2P'(z_3 - z_1) - \frac{1}{6}P'''(z_1 - z_3)\right)Z_{134} \\ &\quad + \frac{1}{3}G_2P''(z_1 - z_3) - 2G_2P(z_1 - z_3)^2 - 8G_2^2P(z_1 - z_3) \\ &\quad + 8G_2^3 - \frac{10}{3}G_4G_2 \end{aligned}$$

in the additive basis given in Proposition 5.7. This allows us to integrate with respect to z_4 and we obtain

$$[\zeta_4^0]P(z_4 - z_1)^2P(z_4 - z_3) = (4G_2P'(z_3 - z_1) - \frac{1}{6}P'''(z_3 - z_1))Z(z_1 - z_3) + \frac{4}{3}G_2P''(z_3 - z_1) + 8G_2^3 - \frac{10}{3}G_4G_2.$$

The integral $[\zeta_2^0]P(z_1 - z_2)P(z_2 - z_3)^2$ is the same as the previous one, with z_4 replaced by z_2 . The product of these two integrals contains the term

$$T = P'''(z_1 - z_3)P'(z_1 - z_3)Z(z_1 - z_3)^2$$

and several terms that can be treated similarly to T , or that can be computed by integration by parts as in the proof of Theorem 5.8 and that finally yield a contribution that is pure of weight 12. To integrate T with respect to z_1 we decompose $T/Z(z_1 - z_3)^2$ in the additive basis:

$$P'''(z)P'(z) = -12G_6P(z) + 24G_6G_2 - \frac{800}{7}G_4^2 - 8P''(z)G_4 + \frac{1}{105}P^{(6)}(z)$$

given by Proposition 5.4. The Z^2 -multiples of the terms containing P or its derivatives can be computed using integration by parts and contribute purely to weight 12. Finally, the constant (in z) multiples of Z^2 are integrated using Proposition 5.9 and yield the contribution of mixed weight.

6. Quasimodularity of graph sums

Motivated by Theorems 4.3 and 4.1 we consider the graph sums

$$S(\Gamma, \mathbf{m}) = \sum_{G \in \Gamma} S(G, \mathbf{m}) \tag{50}$$

over all orientations G of Γ , where

$$S(G, \mathbf{m}) = \sum_{h \in \tilde{\mathbb{N}}^{E(G)}, w \in \mathbb{Z}_+^{E(G)}} \prod_{i \in E(G)} w_i^{m_i+1} q^{h_i w_i} \prod_{v \in V(G)} \delta(v). \tag{51}$$

Here $\tilde{\mathbb{N}}^{E(G)}$ is the height space introduced in (18) and the Dirac symbol $\delta(v)$ was introduced in (29). The goal of this section is to show the quasimodularity of these graph sums.

Theorem 6.1. *If $\mathbf{m} = (m_1, \dots, m_{|E(\Gamma)|})$ is a tuple of even integers, then the graph sums $S(\Gamma, \mathbf{m})$ are quasimodular forms of mixed weight at most $k(\mathbf{m}) := \sum_i (m_i + 2)$.*

The proof consists in splitting the sum into the contributions from the loops and the rest, and then applying the coefficient extraction results from Section 5.1.

The combination of this result with the graph sum theorem and the polynomiality of generalized double Hurwitz numbers with completed cycles immediately gives the first quasimodularity result we are aiming for.

Corollary 6.2. *For any ramification profile Π the counting function $N^\circ(\Pi)$ of connected torus covers of profile Π is a quasimodular form of mixed weight $\leq \text{wt}(\Pi) = |\Pi| + \ell(\Pi)$.*

Proof. As remarked before Theorem 4.3, thanks to Theorem 3.1 we only need to show the quasimodularity of q -brackets of product of p_{ℓ_i} , $i = 1, \dots, n$, i.e. of the expressions appearing in (31) that are sums over graphs with n labelled vertices. By Theorem 4.1 the expressions $\overline{A}'_v = \overline{A}'(\mathbf{w}_v^-, \mathbf{w}_v^+, (\ell_{\#v}))$ appearing on the right hand side of (31) are either zero or polynomials of even degree equal to $\ell_{\#v} + 1 - \ell(\mathbf{w}_v^-) - \ell(\mathbf{w}_v^+)$. Consequently, the product over all vertices of these polynomials \overline{A}'_v has degree $\text{wt}(\Pi) - 2|E(\Gamma)|$. We can now apply Theorem 6.1. \square

The rest of this section is devoted to the proof of Theorem 6.1. As a first technical step we show that $S(\Gamma, \mathbf{m})$, which a priori depends on the heights y_i involved in the definition of the height space, is in fact independent of this choice and can be computed using the limit value $y_i = 0$ for all i .

Lemma 6.3. *Replacing the height space $\widetilde{\mathbb{N}}^{E(G)}$ by*

$$\mathbb{N}_{E(G)} = \{(n_1, \dots, n_{|E(G)|}); n_i \in \{0\} \cup \mathbb{Z}_+ \text{ if } v_+(i) > v_-(i), n_i \in \mathbb{Z}_+ \text{ otherwise}\}$$

does not change the total sum $S(G, \mathbf{m})$.

Proof. We apply the linear change of variables $h'_e = h_e - \delta_e$ with $\delta_e = \varepsilon_{i^+(e)} - \varepsilon_{i^-(e)}$, which maps $\widetilde{\mathbb{N}}^{E(G)}$ onto $\mathbb{N}_{E(G)}$. Each summand for fixed $(w_1, \dots, w_{|E(G)|})$ is then multiplied by

$$q^{-\sum_i \delta_i w_i} \prod_{v \in V(G)} \delta(v) = q^{-\frac{1}{2} \sum_v \varepsilon_v (\sum_{i \in e_-(v)} w_i - \sum_{i \in e_+(v)} w_i)} \prod_{v \in V(G)} \delta(v) = 1.$$

This implies the claim. \square

6.1. The reduced graph

We call an edge of a graph Γ (or an oriented graph G) *neutral* if it is a loop (starting and ending at the same vertex). The other edges are called *essential*. We denote by $E(G) = E_0(G) \cup E_1(G)$ the splitting of the set of edges of G into the neutral and the essential edges. Furthermore, let G_1 denote the oriented graph obtained from G by removing the neutral edges. Similarly, Γ_1 is the graph obtained from Γ by removing the neutral edges. A graph with no neutral edges will be called *reduced*.

Lemma 6.4. *The graph sum $S(\Gamma, \mathbf{m})$ can be factored as*

$$S(\Gamma, \mathbf{m}) = S_0(\Gamma, \mathbf{m}_0) S(\Gamma_1, \mathbf{m}_1)$$

where

$$S_0(\Gamma, \mathbf{m}_0) = \sum_{h \in \mathbb{N}_{E_0(G)}, w \in \mathbb{Z}_+^{E_0(G)}} \prod_{i \in E_0(G)} w_i^{m_i+1} q^{h_i w_i}$$

for any orientation G of Γ , and where $\mathbf{m}_0 = (m_i)_{i \in E_0(G)}$, $\mathbf{m}_1 = (m_i)_{i \in E_1(G)}$.

Proof. This follows from decomposing for every $G \in \Gamma$ the summation in the definition of $S(G, \mathbf{m})$ into the sum over $h \in \mathbb{N}_{E_0(G)}$ and $w \in \mathbb{Z}_+^{E_0(G)}$ and the remaining variables. Since the w_i for $i \in E_0(G)$ drop out of the functions δ , each $S(G, \mathbf{m})$ splits off a factor

$$S_0(G, \mathbf{m}_0) = \sum_{h \in \mathbb{N}_{E_0(G)}, w \in \mathbb{Z}_+^{E_0(G)}} \prod_{i \in E_0(G)} w_i^{m_i+1} q^{h_i w_i}$$

which does not depend on the orientation G of Γ . □

Lemma 6.5. *If $\mathbf{m} = (m_1, \dots, m_{|E(G)|})$ is a tuple of even integers, the neutral contribution $S_0(\Gamma, \mathbf{m}_0)$ is a quasimodular form of mixed weight $k(\mathbf{m}_0)$.*

Proof. The neutral contribution $S_0(\Gamma, \mathbf{m}_0)$ is the product of S_{m_i} over all neutral edges, where $S_m = \sum_{w,h=1}^\infty w^{m+1} q^{hw}$ is the q -expansion of the Eisenstein series G_{m+2} without its constant term for m even. □

The problem is now reduced to computing $S(\Gamma, \mathbf{m})$ for all reduced graphs Γ .

6.2. Contour integrals

The idea of the proof is to write the delta functions appearing in graph sums as contour integrals of some suitably chosen powers of $\zeta = e^{2\pi iz}$ since by the residue theorem

$$\int_\gamma \zeta^w dz = \int_{\gamma'} \zeta^{w-1} \frac{d\zeta}{2\pi i} = \delta_{0,w} \tag{52}$$

where $\gamma(t) = t+iy$ with $0 \leq t \leq 1$ is our standard integration path of height $\Im y \in (0, \Im \tau)$ and $\gamma' = \exp(2\pi i \gamma)$. Recall that we denote derivatives with respect to $u = 2\pi iz$ by primes. By (41) the Fourier developments of the derivatives of P are

$$P^{(m)}(z) = \frac{1}{(2\pi i)^m} \frac{\partial^m}{\partial z^m} P(z) = \sum_{w=1}^\infty \sum_{h=1}^\infty w^{m+1} q^{hw} (\zeta^w + (-1)^m \zeta^{-w}) + \sum_{w=1}^\infty w^{m+1} \zeta^w.$$

Next, we expand the path integrals of products of derivatives of P . In the following lemmas γ_j will be the standard path at height y_j and $y_j < y_{j+1}$.

Lemma 6.6. *Let $I \subset \{2, \dots, n\}$ and assume that all the m_i are even. Then on the domain defined by $|\zeta_i| > |\zeta_1| > |q\zeta_i|$ for all $i \in I$ we have the expansion*

$$\oint_{\gamma_1} \zeta_1^{k_1} \prod_{i \in I} P^{(m_i)}(z_1 - z_i) dz_1 = \sum_{w_i=1}^\infty \prod_{i \in I} w_i^{m_i+1} \cdot \sum_{I=J \cup K} \delta\left(k_1 + \sum_{j \in J} w_j - \sum_{k \in K} w_k\right) \cdot \prod_{j \in J} \left(\sum_{h_j=0}^\infty q^{h_j w_j}\right) \cdot \prod_{k \in K} \left(\sum_{h_k=1}^\infty q^{h_k w_k}\right) \frac{\prod_K \zeta_k^{w_k}}{\prod_J \zeta_j^{w_j}}$$

for every $k_1 \in \mathbb{Z}$.

Proof. Since P is even by definition, so are its derivatives of even order. The lemma follows by expanding the integrand according to the preceding formula for $P^{(m)}$, and by (52) only the term with $k_1 + \sum_{j \in J} w_j - \sum_{k \in K} w_k = 0$ survives. \square

We can use this observation to write the graph sum in terms of derivatives of P . For this purpose, we introduce the following shorthand notations. Let $\mathbf{z} = (z_1, \dots, z_n)$. For a reduced graph Γ_1 with n vertices and N_1 edges, for (y_1, \dots, y_n) fixed as before, and $\mathbf{m}_1 = (m_1, \dots, m_{N_1})$ an N_1 -tuple of even integers, we define

$$P_{\Gamma_1, \mathbf{m}_1}(\mathbf{z}) = \prod_{i \in E(\Gamma_1)} P^{(m_i)}(z_{v_1(i)} - z_{v_2(i)}), \tag{53}$$

where $v_1(i)$ and $v_2(i)$ are the two ends of the edge i . Note that by our parity assumption the function $P^{(m_i)}$ is even and so the expression is independent of the labelling of the ends of edges.

Proposition 6.7. *For a tuple \mathbf{m}_1 of even integers we can express the graph sum as*

$$S(\Gamma_1, \mathbf{m}_1) = [\zeta_n^0, \dots, \zeta_1^0] P_{\Gamma_1, \mathbf{m}_1}(\mathbf{z}), \tag{54}$$

where the coefficient extraction is for the expansion on the domain $|q\zeta_{i+1}| < |\zeta_i| < |\zeta_{i+1}| < 1$ for all i .

Proof. By the general observation in Section 5.3, coefficient extraction is the same operation as the computation of path integrals along standard paths. We compute the right hand side inductively and show that the final expression coincides with the graph sum. We denote by E_1 the set of (the labels of the) edges adjacent to the vertex v_1 . For two subsets of edge labels we define the shorthand notation

$$\delta(J, K) = \delta\left(\sum_{j \in J} w_j - \sum_{k \in K} w_k\right).$$

Using the fact that Γ_1 has no loops, and the parity of P , we rewrite the integrand as

$$P_{\Gamma_1, \mathbf{m}_1}(\mathbf{z}) = \prod_{j \in E_1} P^{(m_j)}(z_1 - z_{v_{\text{other}}(j)}) \cdot \prod_{i \in E \setminus E_1} P^{(m_i)}(z_{v_1(i)} - z_{v_2(i)})$$

where $v_{\text{other}}(j) = v_o(j)$ is the second extremity of the edge j for each edge adjacent to v_1 . We now apply Lemma 6.6 with $k_1 = 0$ and obtain

$$\oint_{\gamma_1} P_{\Gamma_1, \mathbf{m}_1}(\mathbf{z}) = \prod_{i \in E \setminus E_1} P^{(m_i)}(z_{v_1(i)} - z_{v_2(i)}) \cdot \sum_{\substack{w_i=1 \\ i \in E_1}}^{\infty} \left(\prod_{i \in E_1} w_i^{m_i+1} \right) \\ \cdot \sum_{E_1 = J_1 \sqcup K_1} \delta(J_1, K_1) \prod_{j \in J_1} \left(\sum_{h_j=1}^{\infty} q^{h_j w_j} \right) \prod_{k \in K_1} \left(\sum_{h_k=0}^{\infty} q^{h_k w_k} \right) \frac{\prod_{K_1} \zeta_{v_o(k)}^{w_k}}{\prod_{J_1} \zeta_{v_o(j)}^{w_j}}.$$

Consider the new graph $\Gamma^{(1)}$ obtained by removing the edges in E_1 from Γ_1 . We denote by E_2 the set of edges adjacent to v_2 in this new graph, and for each partition

$J_1 \sqcup K_1$ of E_1 we iterate the process by integrating

$$\prod_{i \in E \setminus E_1} P^{(m_i)}(z_{v_1(i)} - z_{v_-(i)}) \cdot \frac{\prod_{K_1} \zeta_{v_o(k)}^{w_k}}{\prod_{J_1} \zeta_{v_o(j)}^{w_j}}$$

along γ_2 , using Lemma 6.6 again. We then consider the graph $\Gamma^{(2)}$ obtained by removing the edges in E_2 from $\Gamma^{(1)}$ and so forth. At the end of this procedure, we obtain

$$\begin{aligned} & [\zeta_n^0, \dots, \zeta_1^0] P_{\Gamma_1, \mathbf{m}_1}(\mathbf{z}) \\ &= \sum_{h_i, w_i} \prod_i w_i^{m_i+1} \cdot \sum_{E_1=J_1 \sqcup K_1} \delta(J_1, K_1) \cdot \prod_{j \in J_1} \sum_{h_j=1}^{\infty} q^{h_j w_j} \cdot \prod_{k \in K_1} \sum_{h_k=0}^{\infty} q^{h_k w_k} \\ & \cdot \sum_{E_2=J_2 \sqcup K_2} \delta(J_2 \sqcup K_1^2, K_2 \sqcup J_1^2) \cdot \prod_{j \in J_2} \sum_{h_j=1}^{\infty} q^{h_j w_j} \cdot \prod_{k \in K_2} \sum_{h_k=0}^{\infty} q^{h_k w_k} \\ & \dots \sum_{E_n=J_n \sqcup K_n} \delta(J_n \sqcup K_{n-1}^n \sqcup \dots, K_n \sqcup J_{n-1}^n \sqcup \dots) \cdot \prod_{j \in J_n} \sum_{h_j=1}^{\infty} q^{h_j w_j} \cdot \prod_{k \in K_n} \sum_{h_k=0}^{\infty} q^{h_k w_k}, \end{aligned}$$

where K_i^j denotes the subset of K_i formed by the edges adjacent to v_j . We recognize the definition of $S(\Gamma_1, m)$, since partitioning E into E_1, \dots, E_n as above gives an orientation G_1 of Γ_1 , and non-realizable orientations have coefficient 0. Note that the last integration with respect to the variable z_n has no effect since the powers of ζ_n cancel out thanks to the delta functions. \square

Proof of Theorem 6.1. In view of the factorization of the relevant quantity, we are interested in the loop contribution and the reduced contribution in Lemma 6.4. The loop contribution is quasimodular by Lemma 6.5, so it suffices to show that the right hand side of (54) is a quasimodular form of mixed weight $\leq k(\mathbf{m}_1)$. This follows from Theorem 5.8, since $P_{\Gamma_1, \mathbf{m}_1} \in \mathcal{J}_n^{(k(\mathbf{m}_1))} \subset \mathcal{Q}_n^{(k(\mathbf{m}_1))}$ by Proposition 5.6. \square

Proof of Theorem 3.2. Let f be a shifted symmetric function of weight k . By Theorem 3.1, f is a linear combination of products of P_ℓ , each product being of weight $\leq k$. Let $P_{\ell_1} \cdots P_{\ell_n}$ be such a product. We claim that $\langle P_{\ell_1} \cdots P_{\ell_n} \rangle_q$ is quasimodular of weight smaller than k . By Theorem 4.3, such a term decomposes as a graph sum (31), where the completed Hurwitz numbers \overline{A}' that appear in the graph sum are some even polynomials in the w_i (Theorem 4.1). The product $\prod_{v \in G} \overline{A}'(\mathbf{w}_v^-, \mathbf{w}_v^+, (\ell_{\#v}))$ is an even polynomial of degree $\leq k - 2|E(G)|$. Considering each monomial of degree $\mathbf{m} = (m_1, \dots, m_{|E(G)|})$, we get the graph sum $S(G, \mathbf{m})$ in (51), which is quasimodular of weight $|\mathbf{m}| + 2|E(G)|$ by Theorem 6.1. By linearity we obtain the quasimodularity of weight $\leq k$ of each $\langle P_{\ell_1} \cdots P_{\ell_n} \rangle_{q, G}$, hence the quasimodularity of each $\langle P_{\ell_1} \cdots P_{\ell_n} \rangle_q$, and finally the quasimodularity of the $\langle f \rangle_q$. \square

7. Siegel–Veech constants

The study of area Siegel–Veech constants for flat surfaces, briefly recalled in Section 7.1, led in [CMZ18] to counting problems for graph sums with a Siegel–Veech weight that we introduce below. We show that the Siegel–Veech weighted graph sums admit a decomposition into graph sums of triple Hurwitz numbers similar to the unweighted case (Proposition 4.2). The main result (Theorem 7.3) in this section is that these graph sums fit into our quasimodularity machinery of Section 5. We use this to give another proof of the quasimodularity of the Siegel–Veech weighted generating series observed in [CMZ18].

Let $\lambda = (\lambda_1 \geq \dots \geq \lambda_k)$ be a partition. For $p \in \mathbb{Z}$ we define the p -th Siegel–Veech weight of λ to be

$$S_p(\lambda) = \sum_{j=1}^k \lambda_j^p. \tag{55}$$

Let $\alpha^{(j)}$ denote the first element of the Hurwitz tuple h_j , defined in (2). We define

$$c_p^*(d, \Pi) = \sum_{j=1}^{|\text{Cov}_d^*(\Pi)|} S_p(\alpha^{(j)}) \quad \text{and} \quad c_p^*(\Pi) = \sum_{d \geq 0} c_p^*(d, \Pi) q^d, \tag{56}$$

where for $* \in \{', 0, \emptyset\}$ we packaged the Siegel–Veech weighted Hurwitz numbers into a generating series. These series admit the following graph sum decomposition.

Proposition 7.1. *The generating series $c'_p(\Pi)$ can be expressed in terms of graph sums of triple Hurwitz numbers as*

$$c'_p(\Pi) = \sum_{\Gamma} \frac{1}{|\text{Aut}(\Gamma)|} c'_p(\Pi, \Gamma),$$

where

$$c'_p(\Pi, \Gamma) = \sum_{\substack{G \in \Gamma \\ h \in \tilde{\mathbb{N}}^{E(G)}, \\ w \in \mathbb{Z}_+^{E(G)}}} \left(\sum_{e \in E(G)} h_e w_e^p \right) \prod_{e \in E(G)} w_e q^{h_e w_e} \prod_{v \in V(G)} A'(\mathbf{w}_v^-, \mathbf{w}_v^+, \mu_v) \delta(v).$$

As a corollary of this and Theorem 7.3 below, we obtain an independent proof of the following quasimodularity result (see also [CMZ18, Theorem 6.4]) without relying on the combinatorial machinery of q -brackets involving \tilde{T}_p (cf. [CMZ18, Sections 14 and 15]).

Corollary 7.2. *For any ramification profile Π and any odd $p \geq -1$ the generating series $c'_p(\Pi)$ for counting covers without unramified components and with p -Siegel–Veech weight as well as the generating series $c_p^\circ(\Pi)$ for counting connected covers with p -Siegel–Veech weight are quasimodular forms of mixed weight $\leq \text{wt}(\Pi) + p + 1$.*

7.1. Relation to area Siegel–Veech constants

The generating functions $c'_{-1}(\Pi)$ admit a nice geometric interpretation in terms of Siegel–Veech constants, which are responsible for counting closed geodesics on flat surfaces. For

a flat surface X we define the function

$$N_{\text{area}}(T, L) = \sum_{\substack{Z \subset X \text{ cylinder} \\ w(Z) \geq L}} \frac{\text{Area}(Z)}{\text{Area}(X)}$$

counting the cylinders filled by closed geodesics on X , weighted by their area. This function is well-known to have a quadratic asymptotic (see e.g. [EM01]), and the number

$$c_{\text{area}}(X) = \lim_{L \rightarrow \infty} \frac{N_{\text{area}}(T, L)}{\pi L^2}$$

is called the (area) *Siegel–Veech constant* associated to X . These constants are interesting both for generic flat surfaces of a given singularity type and for torus covers. It is shown in [EKZ14, Theorem 4] and [CMZ18, Theorem 3.1] that the Siegel–Veech constant for a torus cover of degree d and ramification Π is

$$c_{\text{area}}(d, \Pi) = \frac{3}{\pi^2} \frac{c_{-1}^0(d, \Pi)}{N_d^0(\Pi)}.$$

Thus the series $c_{-1}^*(\Pi)$ can be interpreted as the generating function for the ‘Siegel–Veech numerators’ of Hurwitz spaces. Knowing them to be quasimodular forms, and thus knowing the asymptotic behaviour of both $c_{-1}^0(d, \Pi)$ and $N_d^0(\Pi)$ as $d \rightarrow \infty$, allows one to compute the area Siegel–Veech constant of a generic surface with a given singularity type.

7.2. Siegel–Veech weighted graph sums

In view of Proposition 7.1 we now consider some variants of the graphs sums discussed Section 6, and show that they are quasimodular too. We again define the Siegel–Veech weighted graph sums

$$S^{\text{SV}}(\Gamma, \mathbf{m}) = \sum_{G \in \Gamma} S^{\text{SV}}(G, \mathbf{m}) \tag{57}$$

over all orientations G of Γ , where now

$$S^{\text{SV}}(G, \mathbf{m}) = \sum_{h \in \tilde{\mathbb{N}}^{E(G)}, w \in \mathbb{Z}_+^{E(G)}} \left(\sum_{i \in E(G)} \frac{h_i}{w_i} \right) \prod_{i \in E(G)} w_i^{m_i+1} q^{h_i w_i} \prod_{v \in V(G)} \delta(v). \tag{58}$$

Theorem 7.3. *If $\mathbf{m} = (m_1, \dots, m_{|E(\Gamma)|})$ is a tuple of even integers, then the graph sums $S^{\text{SV}}(\Gamma, \mathbf{m})$ are quasimodular forms of weight at most $k(\mathbf{m}) = \sum_i (m_i + 2)$.*

As in the case of ordinary counting, we can split off the loops and reduce to a simplified height space. The main new ingredient is that the nearly-elliptic function L and q -derivatives of P have the right Fourier expansion whose constant coefficients capture the new graph sums and still fit in the scope of quasimodularity results of Section 5.3.

We decompose $S^{\text{SV}}(\Gamma, \mathbf{m})$ according to the edge i_0 that contributes h_i/w_i in the prefactor. That is, we decompose

$$S^{\text{SV}}(\Gamma, \mathbf{m}) = \sum_{i_0} S_{i_0}^{\text{SV}}(\Gamma, \mathbf{m}), \quad \text{where} \quad S_{i_0}^{\text{SV}}(\Gamma, \mathbf{m}) = \sum_{G \in \Gamma} S_{i_0}^{\text{SV}}(G, \mathbf{m})$$

and where

$$S_{i_0}^{\text{SV}}(G, \mathbf{m}) = \sum_{h \in \tilde{\mathbb{N}}^E(G), w \in \mathbb{Z}_+^{E(G)}} \frac{h_{i_0}}{w_{i_0}} \prod_{i \in E(G)} w_i^{m_i+1} q^{h_i w_i} \prod_{v \in V(G)} \delta(v).$$

Next, we replace the height space $\tilde{\mathbb{N}}^E(G)$ by $\mathbb{N}_{E(G)}$ using an analog of Lemma 6.3.

Lemma 7.4. *Replacing the height space $\tilde{\mathbb{N}}^E(G)$ by $\mathbb{N}_{E(G)}$ in each term $S^{\text{SV}}(G, \mathbf{m})$ does not change the total sum $S^{\text{SV}}(\Gamma, \mathbf{m})$.*

Proof. Let $-G \in \Gamma$ be the graph with the reversed orientation compared to $G \in \Gamma$. We indicate by an additional subscript the space over which the h summation is taken in $S^{\text{SV}}(G, \mathbf{m})$. We will show that

$$S^{\text{SV}}(G, \mathbf{m})_{\tilde{\mathbb{N}}^E(G)} + S^{\text{SV}}(-G, \mathbf{m})_{\tilde{\mathbb{N}}^E(-G)} = S^{\text{SV}}(G, \mathbf{m})_{\mathbb{N}_{E(G)}} + S^{\text{SV}}(-G, \mathbf{m})_{\mathbb{N}_{E(-G)}}.$$

To the first term of the left hand side we apply the change of variables $h'_e = h_e - \delta_e$ with $\delta_e = \varepsilon_{i^+(e)} - \varepsilon_{i^-(e)}$ for the orientation G , which maps $\tilde{\mathbb{N}}^E(G)$ to $\mathbb{N}_{E(G)}$ as in Lemma 6.3. To the second term we apply the change of variables $h'_e = h_e + \delta_e$ with δ_e as before, i.e. associated to the orientation G . It maps $\tilde{\mathbb{N}}^E(-G)$ to $\mathbb{N}_{E(-G)}$. As in Lemma 6.3, this change of variable does not affect the term $q^{h \cdot w}$ (thanks to the delta functions). The statement is then obvious since the terms in δ_e/w_e cancel out. \square

We reduce the problem to the reduced graph using an analog of Lemma 6.4.

Lemma 7.5. *The Siegel–Veech weighted graph sums factor as*

$$S_{i_0}^{\text{SV}}(\Gamma, \mathbf{m}) = \begin{cases} S_{0,i_0}^{\text{SV}}(\Gamma, \mathbf{m}_0) S(\Gamma_1, \mathbf{m}_1) & \text{if } i_0 \text{ is neutral,} \\ S_0(\Gamma, \mathbf{m}_0) S_{i_0}^{\text{SV}}(\Gamma_1, \mathbf{m}_1) & \text{otherwise,} \end{cases}$$

where Γ_1 is the reduced graph underlying Γ and where

$$S_{0,i_0}^{\text{SV}}(\Gamma, \mathbf{m}_0) = \sum_{h \in \mathbb{N}_{E_0(G)}, w \in \mathbb{Z}_+^{E_0(G)}} \frac{h_{i_0}}{w_{i_0}} \prod_{i \in E_0(G)} w_i^{m_i+1} q^{h_i w_i}$$

for any orientation G of Γ .

The contribution of the loops is easily dealt with.

Lemma 7.6. *For \mathbf{m} a tuple of even integers, $S_{0,i_0}^{\text{SV}}(\Gamma, \mathbf{m}_0)$ is a quasimodular form of mixed weight $k(\mathbf{m}_0)$.*

Proof. Clearly

$$S_{0,i_0}^{SV}(\Gamma, \mathbf{m}_0) = \tilde{S}_{m_{i_0}} \prod_{i \neq i_0} S_{m_i}$$

where S_m is defined in Lemma 6.5 and where

$$\tilde{S}_{m_{i_0}} = \sum_{w,h=1}^{\infty} hw^{m_{i_0}} q^{hw} = \begin{cases} D_q S_{m_{i_0}-2} & \text{if } m_{i_0} \geq 2, \\ E_2 + 1/24 & \text{if } m_{i_0} = 0. \end{cases} \quad \square$$

Proof of Theorem 7.3. It remains to show that if i_0 is not neutral, then the graph sum $S_{i_0}^{SV}(\Gamma_1, \mathbf{m}_1)$ is a quasimodular form. We define

$$P_{\Gamma_1, \mathbf{m}_1}^{SV, i_0}(\mathbf{z}) = D_q P^{(m_{i_0}-2)}(z_{v_1(i_0)} - z_{v_2(i_0)}) \prod_{i \in E(\Gamma_1) \setminus \{i_0\}} P^{(m_i)}(z_{v_1(i)} - z_{v_2(i)})$$

if $m_{i_0} \geq 2$, and in the remaining case $m_{i_0} = 0$ we let

$$P_{\Gamma_1, \mathbf{m}_1}^{SV, i_0}(\mathbf{z}) = L(z_{v_1(i_0)} - z_{v_2(i_0)}) \prod_{i \in E(\Gamma_1) \setminus \{i_0\}} P^{(m_i)}(z_{v_1(i)} - z_{v_2(i)}).$$

These definitions are so designed that with the same proof as in Proposition 6.7 we obtain

$$S_{i_0}^{SV}(\Gamma_1, \mathbf{m}_1) = [\zeta_n^0 \dots \zeta_1^0] P_{\Gamma_1, \mathbf{m}_1}^{SV, i_0}(\mathbf{z}).$$

By Proposition 5.6, the function L belongs to $\mathcal{Q}_n^{(0)} \oplus \mathcal{Q}_n^{(2)}$, and the function $D_q P^{(m_{i_0})}$ belongs to $\mathcal{Q}_n^{(m_{i_0}+2)}$. So in any case $P_{\Gamma_1, \mathbf{m}_1}^{SV, i_0}$ belongs to $\mathcal{Q}_n^{(k(\mathbf{m}_1)-2)} \oplus \mathcal{Q}_n^{(k(\mathbf{m}_1))}$. Hence its constant term is quasimodular of mixed weight $\leq k(\mathbf{m}_1)$ by Theorem 5.8. \square

7.3. Proof of main results

Proof of Proposition 7.1. As in the proof of Proposition 4.2, we rely on Proposition 2.4. We only need to justify that counting with Siegel–Veech weight produces an extra factor $h_e w_e^p$ for each edge. This is exactly the weight to put on each cylinder that corresponds to the weight $S_p(\lambda)$ for a Hurwitz tuple. This correspondence is obtained using the standard Siegel–Veech transform as in [CMZ18, proof of Theorem 3.1]. \square

Proof of Corollary 7.2. First, we claim that

$$c'_p(\Pi) = \langle T_p f_{\mu_1} \cdots f_{\mu_n} \rangle_q - \langle T_p \rangle_q \langle f_{\mu_1} \cdots f_{\mu_n} \rangle_q \tag{59}$$

as difference of q -brackets, where T_p is a function on partitions that we introduce now. With the definition⁴

$$T_p(\lambda) = \sum_{\tau \in \mathcal{P}(d)} z_\tau S_p(\tau) \chi^\lambda(\tau)^2$$

⁴ This function arises more naturally as the *hook length moment* $T_p(\lambda) = \sum_{m=1}^{\infty} m^{p-1} N_m(\lambda)$, where $N_m(\lambda)$ is the number of cells in the Young diagram of λ of hook length m . That T_p is a shifted symmetric function if and only if p is odd and positive was a main theme in [CMZ18], but all this is not relevant here. That this definition coincides with the definition of T_p given here is proven in [CMZ18, Corollary 13.2].

[CMZ18, Proposition 6.3] implies that

$$c_p(\Pi) = \sum_{\lambda \in \mathbb{P}} (T_p f_{\mu_1} \cdots f_{\mu_n})(\lambda) q^\lambda.$$

From [CMZ18, Proposition 6.2] we deduce

$$c'_p(\Pi) = (q)_\infty c_p(\Pi) - (q)_\infty c_p() N'_p(\Pi).$$

Since $(q)_\infty = (\sum_{\lambda \in \mathbb{P}} q^\lambda)^{-1}$, this is equivalent to the equation claimed in (59), by the definition of q -brackets.

Second, we use the linearity of the brackets to show

$$\begin{aligned} \langle T_p p_{\ell_1} \cdots p_{\ell_n} \rangle_q - \langle T_p \rangle_q \langle p_{\ell_1} \cdots p_{\ell_n} \rangle_q = \\ \sum_{\Gamma} \frac{1}{|\text{Aut}(\Gamma)|} \sum_{G \in \Gamma} \sum_{\substack{h \in \tilde{\mathbb{N}}^{E(G)} \\ w \in \mathbb{Z}_+^{E(G)}}} \left(\sum_{e \in E(G)} h_e w_e^p \right) \prod_{e \in E(G)} w_e q^{h_e w_e} \prod_{v \in V(G)} \bar{A}'(\mathbf{w}_v^-, \mathbf{w}_v^+, (\ell_{\#v})) \delta(v), \end{aligned} \tag{60}$$

which invokes the polynomial Hurwitz numbers $\bar{A}'(\mathbf{w}_v^-, \mathbf{w}_v^+, (\ell_{\#v}))$. In fact, we can consider both sides of this equation as expressions in n arguments as in Theorem 4.3. Since we can write $p_\ell = \sum_{\mu} c_{\ell, \mu} f_\mu$, multilinearity of both sides reduces the claim to the case of arguments f_{μ_i} , which is exactly the combination of (59) and the claim in Proposition 7.1.

By Theorem 4.1 the polynomials $\bar{A}'(\mathbf{w}_v^-, \mathbf{w}_v^+, (\ell_{\#v}))$ are even, so if p is odd the parity hypothesis of Theorem 7.3 is met and this theorem implies that the expression in (60) is a quasimodular form. Since the f_μ can be expressed as polynomials in the p_ℓ by Theorem 3.1, this implies the quasimodularity of $c'_p(\Pi)$ we claimed. The weight can be determined as in the proof of Corollary 6.2. \square

8. Tropical covers and quasimodularity graph by graph

The main result of [BBBM17] is the expression of the tropical Hurwitz number generating function in terms of a sum over Feynman graphs. The goal of this section is to show that those results are the special case of simple branch points of our results, when stated in the language of tropical covers. More precisely, we show here that our correspondence theorem in Proposition 2.4 has the Correspondence Theorem [BBBM17, Theorem 2.13] (see also Theorems 2.20 and 2.30 in loc. cit.) as an immediate corollary when stated in the language of tropical covers. In particular, for simple branching (i.e. ramification profile $\Pi = ((2), \dots, (2))$), our counting problem is equivalent to counting tropical covers.

8.1. Tropical covers

We recall here the definition of a tropical curve and a tropical cover, following [BBBM17].

Definition 8.1. A *tropical curve* C is a connected finite trivalent metric graph. An *elliptic tropical curve* consists of one edge forming a circle labelled with its length. Let E be the elliptic tropical curve of length 1. A map $\pi : C \rightarrow E$ is a *tropical cover* of E if it is continuous, non-constant, integer affine on each edge and respects a balancing condition at every vertex of C .

In this setting, the *weight* w_e of an edge e for the graph is defined as the slope of $\pi|_e$, and the *degree* of the cover as

$$d = \sum_{P \in C, \pi(P)=p} w_{e_P},$$

where p is a generic point. For each vertex we can group the outgoing half-edges according to the half-edges of E they map to. The cover is called *balanced* if for each vertex the sums of the weights of the two groups agree.

An appropriate way to count tropical covers is coded in the notion of tropical Hurwitz numbers.

Definition 8.2. Fix branch points p_1, \dots, p_{2g-2} in the tropical elliptic curve E . The *tropical Hurwitz number* is the weighted number of isomorphism classes of degree d covers from a genus g curve C with branch points at the p_i . Here, a tropical cover π is weighted by the multiplicity

$$\text{mult}(\pi) = \frac{1}{|\text{Aut}(\pi)|} \prod_e w_e.$$

The *combinatorial type* of a tropical curve is its homeomorphism class, i.e. the underlying graph without lengths on the edges. These graphs are called *Feynman graphs* in physics literature. They correspond to our notion of (associated) *global graph*, with the vertex labelling removed.

Our correspondence theorem implies the following correspondence result for simple ramification covers branched over $n = 2g - 2$ points in terms of tropical covers. The number of covers is independent, both for flat surface covers and for tropical covers, of the base elliptic curve and the branch point location. In the following corollary we thus fix E and the branch points on the flat side as in Section 2.3, more precisely for convenience at $\varepsilon_i = i/n$, and on the tropical side we locate the branch points at $p_i = i/n$. In particular the heights h_e are in $\frac{1}{n}\mathbb{Z}_{\geq 1}$.

Corollary 8.3. *There is a bijective correspondence between*

- (i) *the flat surfaces (X, ω) with connected coverings $p : X \rightarrow E$ of degree d of the square torus E , with $\omega = p^*\omega_E$, and with simple ramification profile, weighted by $1/|\text{Aut}(\pi)|$, and*
- (ii) *the isomorphism classes of weighted tropical covers $\pi : C \rightarrow E$ of degree d , where the weight of a tropical cover corresponds to its multiplicity $\text{mult}(\pi)$.*

Proof. This is a consequence of Proposition 2.4. Each cover corresponds to a trivalent graph with a collection of numbers (w_e, h_e, t_e) corresponding to the widths, the heights

and the twists of the cylinders. We define the tropical curve C to be the global graph Γ with edge lengths $\ell_e = h_e/w_e$. If e is an edge from vertex i to vertex j , we define the tropical cover on e to be the map of slope $w_e \in \mathbb{N}$ to the multi-segment from p_i to p_j making $\lfloor h_e \rfloor$ full turns. Note that this is well-defined, since for such an edge we have $h_e - (j - i)/n \in \mathbb{Z}$. The tropical balancing condition is a restatement of $|\mathbf{w}_v^+| = |\mathbf{w}_v^-|$ for every vertex v . Note that on the one hand $d = \sum_e w_e h_e$, but on the other hand the flat picture immediately implies $d = \sum_{e \ni \pi^{-1}(P)} w_e$, where the sum is over all edges e such that the corresponding cylinder contains the preimage of a given point $P \in E$. This implies that the tropical cover we defined indeed has degree d . The map we define forgets the twist t_e , but this is accounted for in the multiplicity $\text{mult}(\pi)$. Note that the double Hurwitz number of a trivalent local surface with a simple branch point is equal to 1 and hence can be omitted. Besides the twist, our map has an obvious converse, associating to a tropical cover the slopes w_e and $h_e = w_e \ell_e$ and the latter are indeed in $\frac{1}{n}\mathbb{Z}_{\geq 1}$ by our convention on the location of the points p_i .

Proposition 2.4 is stated at the level of coverings without unramified components. The correspondence descends under the given hypothesis of simple branching (more generally: in case of only one ramified point over each branch point) to a correspondence of connected covers by the usual inclusion-exclusion principle, since the obstruction of disconnected local surfaces (mentioned after the proof of Proposition 2.4) is ruled out by this hypothesis. \square

In this correspondence the lengths of the edges of the tropical curves are the reciprocals of the moduli $m_e = w_e/h_e$. This is the natural choice when viewing a tropical curve as the dual graph of the special fiber in a degenerating family of smooth curves. Indeed the reciprocal moduli m_e^{-1} of the cylinders correspond (up to a common rescaling) to the number of Dehn twists performed under the monodromy around the special fiber, and this in turn corresponds to a local equation $xy = t^{m_e^{-1}}$ in the stable model of the generating fiber (see e.g. [Möl08, paragraph preceding Theorem 2.4]). Since such a singularity is resolved by a chain of $m_e^{-1} - 1$ rational curves in the semistable model with regular total space, the tropicalization map [Viv13] provides this edge with length m_e^{-1} .

8.2. Counting graph by graph

For coverings with simple ramification, or equivalently for trivalent graphs, the quasimodularity results hold for each individual graph.

Corollary 8.4. *Let $\Pi = ((2), \dots, (2))$. Then for any trivalent graph Γ the contribution $N'(\Pi, \Gamma)$ (resp. $c'_p(\Pi, \Gamma)$) of the graph Γ to the total count is a quasimodular form of mixed weight $\leq \text{wt}(\Pi) = |\Pi| + \ell(\Pi)$.*

These graph sums have a geometric interpretation: we count only surfaces with a fixed type. This result is a refinement of the quasimodularity results of [EO01] and [CMZ18] in the case of principal strata.

The weight of the quasimodular form $N'(\Pi, \Gamma)$ is not necessarily pure as shown by the example of $\Pi = ((2), (2), (2), (2))$ in Section 9. Note that in our convention, the

vertices of Γ are labelled. Our examples show that for a fixed underlying unlabelled trivalent graph G the *sum over all labellings* is a quasimodular form of *pure weight* $\text{wt}(\Pi) = |\Pi| + \ell(\Pi)$ for $\Pi = ((2), (2))$ and $\Pi = ((2), (2), (2), (2))$. This purity result might hold in general.

Proof of Corollary 8.4. Since for simple ramification $f_2 = P_2/2$ is a completed cycle, the corollary is a straightforward consequence of Theorems 6.1 and 7.3. \square

9. Examples

The examples here have four objectives. First we show how to compare the computations of Zorich [Zor02] diagram by diagram with the counting by global graphs and local surfaces used here. Second, we emphasize the main difficulty in the naive computation of the graph sums: If we work with non-completed cycles, the graph sum is not quasimodular for each graph separately, not even after summing over all the orientations. This sum belongs to the ring generated by all the ‘Eisenstein series’ G_k , including odd k (compare Section 5.1), and their derivatives. Only cancellations that become very delicate as the complexity of the ramification datum grows ensure that the total result is a quasimodular form.

Third, we illustrate the mechanism for proving quasimodularity of the Siegel–Veech weighted counting. This is most transparent in the case of the principal stratum in genus 2, the simple branching profile $\Pi = ((2), (2))$, where no difficulty stemming from completed cycles is present.

Finally, we compute the quasimodular forms individually for the trivalent graphs corresponding to genus 3 covers and $\Pi = ((2), (2), (2), (2))$.

9.1. Branching profile $\Pi = (3)$, the stratum $\mathcal{H}(2)$

If we count geometrically as in Section 2.3, the global graphs of a stratum with just one singularity have just one node, and the number of loops is at most 2 for genus 2 curves.



Fig. 3. The global graphs for $\mathcal{H}(2)$: one loop (Γ_1) or two loops (Γ_2).

9.1.1. Computation by diagrams. We review the computations of Zorich [Zor02] of torus covers in this stratum, made with the aim of computing the Masur–Veech volume of $\mathcal{H}(2)$. We compute $N^\circ(G, \Pi) = N'(G, \Pi)$ for Γ_1 and Γ_2 and all their orientations for the ramification profile $\Pi = (3)$ consisting of a three-cycle.

In terms of square-tiled surfaces in $\mathcal{H}(2)$, a first possible pattern is presented on the left of Figure 4. The picture on the right represents the ribbon graph made from a tubular

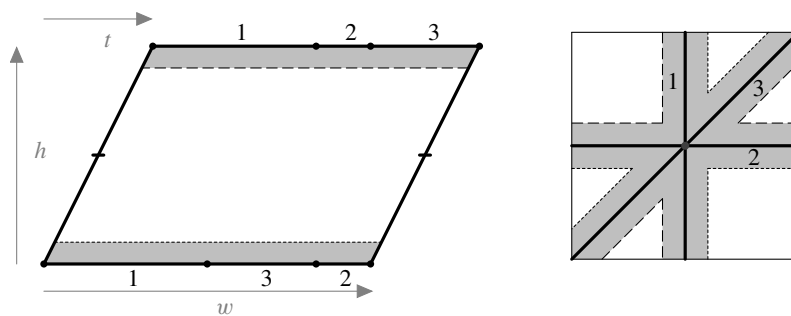

Fig. 4. Diagram with one cylinder.

neighbourhood of the boundary of the horizontal cylinder. It is drawn on a torus since it cannot be embedded in the plane. It corresponds to the only one ribbon graph with one vertex of valency 6 and two faces (boundary components).

As integer parameters for this square-tiled surface, we use the width of the cylinder w , the height h , the twist t , and the lengths of the saddle connexions ℓ_1, ℓ_2, ℓ_3 . They are related by

$$w = \ell_1 + \ell_2 + \ell_3 \quad \text{and} \quad t \in \{0, 1, \dots, w - 1\}. \tag{61}$$

The generating function for counting square-tiled surfaces of this type is then

$$\begin{aligned} S(\mathcal{C}_1) &:= \sum_{\substack{h, \ell_1, \ell_2, \ell_3=1 \\ hw \geq 3}}^{\infty} \sum_{t=0}^{w-1} q^{hw} \delta(w - \ell_1 - \ell_2 - \ell_3) \\ &= \sum_{\substack{w, h=1 \\ hw \geq 3}}^{\infty} wq^{hw} \left(\frac{1}{6}w^2 - \frac{1}{2}w + \frac{1}{3}\right) = \frac{1}{6}S_3 - \frac{1}{2}S_2 + \frac{1}{3}S_1, \end{aligned} \tag{62}$$

where $\frac{1}{6}w^2 - \frac{1}{2}w + \frac{1}{3}$ is the number of solutions of (61), and where

$$S_i = \sum_{w, h=1}^{\infty} w^i q^{hw} = G_{i+1} + \frac{B_{i+1}}{2(i+1)}.$$

From this formula we see that the generating function $N'(\Gamma_1, (3))$ is not a quasimodular form of weight ≤ 6 , since the ‘Eisenstein series’ G_3 is not.

Figure 5 represents a pattern for a square-tiled surface in $\mathcal{H}(2)$ corresponding to the graph Γ_2 , i.e., with two horizontal cylinders, and its associated ribbon graph. The integer parameters $w_1, w_2, h_1, h_2, t_1, t_2, \ell_1, \ell_2, \ell_3$ are related by

$$w_2 = \ell_1 = \ell_3, \quad w_1 = \ell_1 + \ell_2, \quad t_1 \in \{0, \dots, w_1 - 1\}, \quad t_2 \in \{0, \dots, w_2 - 1\}.$$

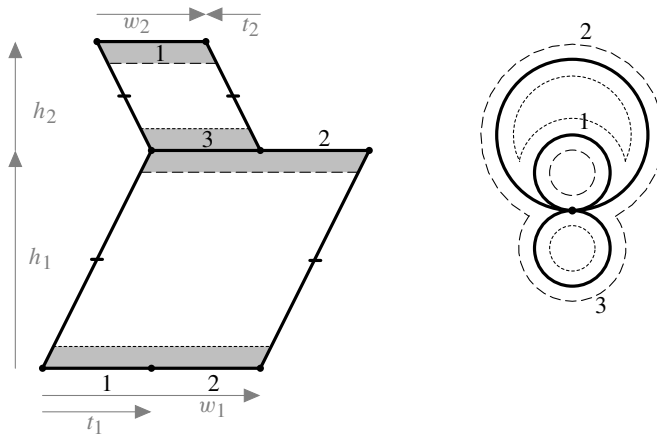

Fig. 5. Diagram for two cylinders.

The generating function for this type of square-tiled surfaces is

$$\begin{aligned}
 S(\mathcal{C}_2) &:= \sum_{\substack{w_1, h_1, w_2, h_2, \ell_1, \ell_2=1 \\ w, h \geq 3}}^{\infty} \sum_{t_1=0}^{w_1-1} \sum_{t_2=0}^{w_2-1} q^{h_1 w_1 + h_2 w_2} \delta(w_2 - \ell_1) \delta(w_1 - \ell_1 - \ell_2) \\
 &= \sum_{\substack{w_1, w_2, h_1, h_2=1 \\ w, h \geq 3}}^{\infty} w_1 w_2 q^{h_1 w_1 + h_2 w_2} \mathbb{1}_{\{w_1 > w_2\}}.
 \end{aligned} \tag{63}$$

We now compute that

$$\sum_{w_1, w_2, h_1, h_2=1}^{\infty} w_1 w_2 q^{h_1 w_1 + h_2 w_2} \mathbb{1}_{\{w_1 > w_2\}} = \frac{1}{2}(A - B),$$

where

$$\begin{aligned}
 A &= \sum_{w_1, w_2, h_1, h_2=1}^{\infty} w_1 w_2 q^{h_1 w_1 + h_2 w_2} = S_1^2, \\
 B &= \sum_{w_1, w_2, h_1, h_2=1}^{\infty} w_1 w_2 q^{h_1 w_1 + h_2 w_2} \mathbb{1}_{\{w_1 = w_2\}} = D_q S_1 - S_2.
 \end{aligned}$$

Here again, the non-quasimodularity comes from the factor $S_2 = G_3$. Summing over the two configurations we see that the terms in S_2 cancel out,

$$\left(\frac{1}{6} S_3 - \frac{1}{2} S_2 + \frac{1}{3} S_1\right) + \frac{1}{2}(S_1^2 - D S_1 + S_2) = \frac{3}{2} G_2^2 - \frac{1}{4} G_4 + \frac{3}{8} G_2 + \text{const},$$

resulting in a quasimodular form, as claimed.

9.1.2. *Computation by local graphs and global graphs.* In the formalism of this paper, the ribbon graph in the first case (i.e. the global graph Γ_1) corresponds to a cover of the cylinder \mathbb{P}^1 , ramified with profile $(3, 1, \dots, 1)$ at 1, and with (w) at 0 and ∞ . The corresponding triple Hurwitz number $A'(w, w, (3))$ is just the number of such ribbon graphs, so it is the number of solutions $(\ell_1, \ell_2, \ell_3) \in \mathbb{N}^3$ of (61). Consequently,

$$S(C_1) = N'(\Gamma_1, (3)) = \sum_{w,h=1}^{\infty} wq^{wh} A'(w, w, (3)).$$

For the second graph Γ_2 , the ribbon graph corresponds here to a cover of \mathbb{P}^1 , ramified of profile $(3, 1, \dots, 1)$ over 1, (w_1, w_2) over 0 and ∞ . The number of such covers or such ribbon graphs is

$$A'(\mathbf{w}, \mathbf{w}, (3)) = \begin{cases} 1 & \text{if } w_1 \neq w_2, \\ 0 & \text{if } w_1 = w_2, \end{cases} \quad \mathbf{w} = (w_1, w_2).$$

Before passing to the computation using completed cycles, we tabulate the contribution of each polynomial in shifted symmetric functions appearing in the expression of

$$f_3 = \frac{1}{3}P_3 - \frac{1}{2}P_1^2 + \frac{5}{12}P_1$$

to the local polynomials $A^\circ(\mathbf{w}^-, \mathbf{w}^+, (3))$ and the contribution $\langle \cdot \rangle_q$. The table below shows that the contribution of each diagram individually is not quasimodular because the contribution of P_1^2 for graphs with only one vertex is not polynomial. It is however piecewise polynomial, showing also that all the hypotheses in Theorem 4.1 are needed in order to get a globally polynomial contribution.

	$A^\circ(w, w, (3))$	$\langle \cdot \rangle_{q, G_1}$	$A^\circ(\mathbf{w}, \mathbf{w}, (3))$		$\langle \cdot \rangle_{q, G_2}$
			$w_1 \neq w_2$	$w_1 = w_2$	
f_3	$\frac{1}{6}w^2 - \frac{1}{2}w + \frac{1}{3}$	$\frac{1}{6}S_3 - \frac{1}{2}S_2 + \frac{1}{3}S_1$	1	0	$S_1^2 - DS_1 + S_2$
$P_3/3$	$\frac{1}{6}w^2 - \frac{1}{12}$	$\frac{1}{6}S_3 - \frac{1}{12}S_1$	2	2	$2S_1^2$
P_1^2	w	S_2	2	4	$2(S_1^2 + DS_1 - S_2)$
P_1	1	S_1	0	0	0

9.1.3. *Computation using q -brackets of completed cycles.* Last, we compute $\langle f_3 \rangle_q$ using

$$\langle f_3 \rangle_q = \frac{1}{3}\langle P_3 \rangle_q - \frac{1}{2}\langle P_1^2 \rangle_q + \frac{5}{12}\langle P_1 \rangle_q.$$

The main difference from the previous computation will be the term $\langle P_1^2 \rangle_q$ that we could interpret as a graph sum for a graph with two vertices.

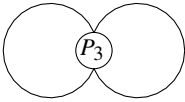
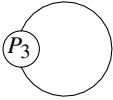
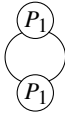
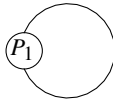
	$A^\circ(\mathbf{w}^-, \mathbf{w}^+, \mu)$	$\langle \cdot \rangle_q$
	6	$6S_1^2$
	$\frac{1}{2}w^2 - \frac{1}{4}$	$\frac{1}{2}S_3 - \frac{1}{4}S_1$
	1 and 1	$S_1^2 + DS_1$
	1	S_1

In these cases, all the local contributions are global polynomials and moreover even functions, so the contributions of the completed cycles for each graph are quasimodular forms.

9.2. Branching profile $\Pi = ((2), (2))$, the stratum $\mathcal{H}(1, 1)$

For this stratum, as for all principal strata, all the contributions of the individual graphs to the counting function $N^\circ((12), (12))$ for the ramification profile consisting of two transpositions are quasimodular forms, since $f_2 = \frac{1}{2}P_2$ is equal to a completed cycle. For $\mathcal{H}(1, 1)$ there is only one possible global graph up to relabelling the vertices.

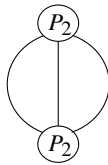
	$A^\circ((w_1), (w_2, w_3), (2))$	$\langle P_2 \rangle_q$
	2 and 2	$2S_{1,1}$

Among the eight orientations of Γ the two with all arrows ending at the same vertex do not contribute to the total sum (27). By symmetry considerations the remaining six orientations have the same contribution, and contribute with the factor 1/6 to (27) because of the automorphism group permuting the edges. Consequently,

$$N^\circ((12), (12)) = \frac{1}{6}S(\Gamma), \quad \text{where} \quad S(\Gamma) = [\zeta_1^0 \zeta_2^0]P(z_1 - z_2)^3 = [\zeta^0]P(z)^3,$$

and on the other hand (expressed in the height space convention of Lemma 6.3)

$$S(\Gamma) = 6S_{1,1} \quad \text{where} \quad S_{1,1} = \sum_{w_2, w_3, h_1=1, h_2, h_3=0}^{\infty} w_2 w_3 (w_2 + w_3) q^{w_2(h_1+h_2)+w_3(h_1+h_3)}.$$

We can compute the constant coefficient using the algorithm provided by Theorem 5.8 and the decomposition

$$P(z)^3 = \frac{1}{120} P^{(4)}(z) + G_2 P''(z) + (12G_2^2 + 3G_4)P(z) - 16G_2^3 + 4G_4G_2 + \frac{7}{30}G_6$$

to finally obtain

$$N^\circ((12), (12)) = -\frac{8}{3}G_2^3 + \frac{2}{3}G_4G_2 + \frac{7}{180}G_6.$$

As a cross-check, since we know that the graph sum is quasimodular, we can determine this quasimodular form by computing the first terms of the generating series:

$$N^\circ((12), (12)) = 2q^2 + 16q^3 + 60q^4 + 160q^5 + 360q^6 + 672q^7 + 1240q^8 + O(q^9).$$

9.2.1. Siegel–Veech generating function. Here we illustrate the method of proof of Theorem 7.3 by evaluating the first interesting contribution $S^{SV}(\mathcal{H}(1, 1))$. We use the branch point normalization of heights 0 and 1/2 (to exploit the symmetry). The generating function is

$$S_{1,1}^{SV} = \sum_{\substack{(h_1, h_2, h_3) \in (\mathbb{N}+1/2)^3 \\ (w_1, w_2, w_3) \in (\mathbb{N}^*)^3}} \left(\frac{h_1}{w_1} + \frac{h_2}{w_2} + \frac{h_3}{w_3} \right) w_1 w_2 w_3 \delta(w_3 - w_1 - w_2) q^{h \cdot w}.$$

We will show that

$$S_{1,1}^{SV} = -\frac{10}{3}G_2^3 + \frac{5}{6}G_2G_4 + \frac{7}{144}G_6.$$

With our convention, since the polynomial contribution of P_2 is 1, we get

$$c^\circ((12), (12)) = \frac{1}{6}(S_1^{SV}(\Gamma, 0) + S_2^{SV}(\Gamma, 0) + S_3^{SV}(\Gamma, 0))$$

where

$$S_1^{SV}(\Gamma, 0) = \sum_{G \in \Gamma} \sum_{\substack{w \in \mathbb{N}^* \\ h \in \mathbb{Z}_{E(G)}}} h_1 w_2 w_3 \delta \left(\sum_{i \in e^+(v)} w_i - \sum_{i \in e^-(v)} w_i \right) q^{h \cdot w}.$$

One can check directly on this example that

$$S_1^{SV}(\Gamma, 0) = [\zeta^0]L(z)P(z)^2 = S_2^{SV}(\Gamma, 0) = S_3^{SV}(\Gamma, 0)$$

(the integration with respect to the second variable z_2 is not necessary), and that

$$S_{1,1}^{SV} = \frac{1}{2}S_1^{SV}(\Gamma, 0) = c^\circ((12), (12)).$$

The proof of Theorem 7.3 also provides an algorithm for computation. The decomposition of L in the standard generators has been given in (46). Using

$$P(z)^2 = \frac{1}{6}P''(z) + 4G_2P(z) - 4G_2^2 + \frac{5}{3}G_4$$

and the decomposition of $P(z)^3$ given previously, we obtain

$$[\zeta^0]Z(z)^2P(z)^2 = \frac{16}{3}G_2^3 - \frac{2}{3}G_2^2 - \frac{8}{3}G_4G_2 + \frac{5}{18}G_4 + \frac{7}{180}G_6$$

and

$$[\zeta^0](\frac{1}{2}P(z) - G_2 + \frac{1}{12})P(z)^2 = -4G_2^3 - \frac{1}{3}G_2^2 + \frac{1}{3}G_4G_2 + \frac{5}{36}G_4 + \frac{7}{60}G_6.$$

Altogether, we conclude that

$$c^\circ((12), (12)) = \frac{1}{2}[\zeta^0]LP^2 = -\frac{10}{3}G_2^3 + \frac{5}{6}G_2G_4 + \frac{7}{144}G_6 = \frac{5}{4}S(\mathcal{H}(1, 1)).$$

The Siegel–Veech constant for the stratum $\mathcal{H}(1, 1)$ is $5/4$ and this proportionality of generating series is expected by the ‘non-varying property’ of $\mathcal{H}(1, 1)$ (see the discussion in [CMZ18, Section 17]).

9.3. *Branching profile $\Pi = ((2), (2), (2), (2))$, the stratum $\mathcal{H}(1^4)$*

We end this range of examples with the stratum $\mathcal{H}(1^4)$, first to show the effect of the labelling of the zeros and to compute the quasimodular forms for individual graphs. There are only two trivalent connected (multi)graphs with four vertices, depicted in Figure 6. The graphs Γ are obtained by labelling the vertices of these graphs.



Fig. 6. Global graphs for $\mathcal{H}(1^4)$: type 1 (left) and type 2 (right).

For the first graph, we can use the horizontal and vertical flip and assume that the bottom left vertex is labelled by 1. Among the six ways to label the remaining vertices, our normalization of the integration paths (or equivalently height spaces, see 5.3) results in two essentially different quasimodular forms.

The numbering on the left gives the quasimodular form

$$\begin{aligned} A &= [\zeta^0]P(z_1 - z_2)^2P(z_1 - z_4)P(z_2 - z_3)P(z_3 - z_4)^2 \\ &= 4q^2 + 224q^3 + 3088q^4 + 21888q^5 + 105136q^6 + 388288q^7 + 1197280q^8 + O(q^9) \\ &= (-256G_2^6 + \frac{640}{3}G_4G_2^4 + \frac{112}{9}G_6G_2^3 - \frac{400}{9}G_4^2G_2^2 - \frac{140}{9}G_6G_4G_2 + \frac{2000}{81}G_4^3 + \frac{49}{108}G_6^2) \\ &\quad + (-\frac{256}{3}G_4G_2^3 - \frac{16}{5}G_6G_2^2 + \frac{320}{21}G_4^2G_2 + \frac{28}{9}G_6G_4), \end{aligned} \tag{64}$$

which we computed in Section 5.4, and there is a second labelling that results in the same quasimodular form, in fact

$$A = [\zeta^0]P(z_1 - z_4)^2P(z_1 - z_2)P(z_2 - z_3)^2P(z_3 - z_4).$$

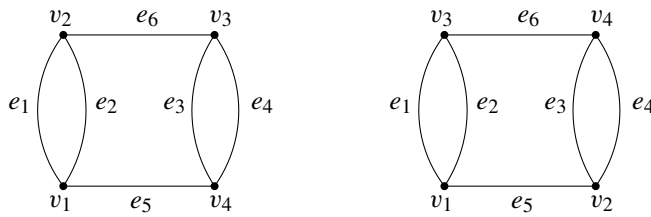

Fig. 7. Labelled graph of type 1 for $\mathcal{H}(1^4)$.

The numbering on the right of Figure 7 and three other numberings produce the quasi-modular form

$$\begin{aligned}
 B &= [\zeta^0]P(z_1 - z_3)^2P(z_1 - z_2)P(z_2 - z_4)^2P(z_3 - z_4) \\
 &= 40q^4 + 448q^5 + 2848q^6 + 11776q^7 + 41744q^8 + O(q^9) \\
 &= (-256G_2^6 + \frac{640}{3}G_4G_2^4 + \frac{112}{9}G_6G_2^3 - \frac{400}{9}G_4^2G_2^2 - \frac{140}{9}G_6G_4G_2 + \frac{2000}{81}G_4^3 + \frac{49}{108}G_6^2) \\
 &\quad + (\frac{128}{3}G_4G_2^3 + \frac{8}{5}G_6G_2^2 - \frac{160}{21}G_4^2G_2 - \frac{14}{9}G_6G_4). \tag{65}
 \end{aligned}$$

This difference illustrates a wall-crossing phenomenon: fixing the heights of the zeros (the domain of integration) and changing the labelling of the zeros is the same as fixing the labelling of the zeros and changing the integration domain. Equations (64) and (65) are the contour integrals of the same function on two different domains. Note also that these contributions are of weight 12 and 10, and their weight 12 parts coincide, whereas their weight 10 parts coincide up to a factor of -2 .

The total contribution of this graph is then

$$\begin{aligned}
 2A + 4B &= 6(-256G_2^6 + \frac{640}{3}G_4G_2^4 + \frac{112}{9}G_6G_2^3 - \frac{400}{9}G_4^2G_2^2 - \frac{140}{9}G_6G_4G_2 \\
 &\quad + \frac{2000}{81}G_4^3 + \frac{49}{108}G_6^2).
 \end{aligned}$$

The second graph in Figure 6 is totally symmetric: there is only one way to label the vertices. Its contribution is

$$\begin{aligned}
 C &= [\zeta^0]P(z_1 - z_2)P(z_1 - z_3)P(z_1 - z_4)P(z_2 - z_3)P(z_2 - z_4)P(z_3 - z_4) \\
 &= -384G_2^6 + 480G_4G_2^4 - 200G_4^2G_2^2 + \frac{250}{9}G_4^3.
 \end{aligned}$$

The total connected generating function for the graph of type 1 is then

$$\begin{aligned}
 &\frac{1}{4}(2A + 4B) + C \\
 &= -768G_2^6 + 800G_4G_2^4 + \frac{56}{3}G_6G_2^3 - \frac{800}{3}G_4^2G_2^2 - \frac{70}{3}G_6G_4G_2 + \frac{1750}{27}G_4^3 + \frac{49}{72}G_6^2 \\
 &= 2q^2 + 160q^3 + 2448q^4 + 18304q^5 + 90552q^6 + 341568q^7 + 1068928q^8 + O(q^9).
 \end{aligned}$$

The factor 4 is due to the automorphism group of each labelled graph of type 1.

Acknowledgments. We are very grateful to Alex Eskin for sharing with us the manuscript of an old project with Andrei Okounkov that was at the origin of the notion of completed cycles (see the reference to [12] in [OP06]). We also thank Don Zagier for many fruitful conversations on quasimodular forms and Dmitry Zvonkine and Kathrin Bringmann for useful suggestions and comments. We moreover thank the referee whose comments helped to improve the exposition of the paper.

This research was conducted at the *Max-Planck-Institut für Mathematik, Bonn*, whose hospitality we gratefully acknowledge.

Research of the first author is supported by the Fondation Mathématique Jacques Hadamard.

Research of the second author is partially supported by the DFG-project MO 1884/1-1.

References

- [AEZ16] Athreya, J. S., Eskin, A., Zorich, A.: Right-angled billiards and volumes of moduli spaces of quadratic differentials on \mathbb{CP}^1 (with an appendix by J. Chaika). *Ann. Sci. École Norm. Sup. (4)* **49**, 1311–1386 (2016) [Zbl 1372.32020](#) [MR 3592359](#)
- [BCOV94] Bershadsky, M., Cecotti, S., Ooguri, H., Vafa, C.: Kodaira–Spencer theory of gravity and exact results for quantum string amplitudes. *Comm. Math. Phys.* **165**, 311–427 (1994) [Zbl 0815.53082](#) [MR 1301851](#)
- [BO00] Bloch, S., Okounkov, A.: The character of the infinite wedge representation. *Adv. Math.* **149**, 1–60 (2000) [Zbl 0978.17016](#) [MR 1742353](#)
- [BBBM17] Böhm, J., Bringmann, K., Buchholz, A., Markwig, H.: Tropical mirror symmetry for elliptic curves. *J. Reine Angew. Math.* **732**, 211–246 (2017) [Zbl 1390.14191](#) [MR 3717092](#)
- [CMZ18] Chen, D., Möller, M., Zagier, D.: Quasimodularity and large genus limits of Siegel–Veech constants. *J. Amer. Math. Soc.* **31**, 1059–1163 (2018) [Zbl 1404.32025](#) [MR 3836563](#)
- [Dij95] Dijkgraaf, R.: Mirror symmetry and elliptic curves. In: *The Moduli Space of Curves (Texel Island, 1994)*, *Progr. Math.* 129, Birkhäuser Boston, Boston, MA, 149–163 (1995) [Zbl 0913.14007](#) [MR 1363055](#)
- [EKZ14] Eskin, A., Kontsevich, M., Zorich, A.: Sum of Lyapunov exponents of the Hodge bundle with respect to the Teichmüller geodesic flow. *Publ. Math. Inst. Hautes Études Sci.* **120**, 207–333 (2014) [Zbl 1305.32007](#) [MR 3270590](#)
- [EM01] Eskin, A., Masur, H.: Asymptotic formulas on flat surfaces. *Ergodic Theory Dynam. Systems* **21**, 443–478 (2001) [Zbl 1096.37501](#) [MR 1827113](#)
- [EMZ03] Eskin, A., Masur, H., Zorich, A.: Moduli spaces of Abelian differentials: the principal boundary, counting problems, and the Siegel–Veech constants. *Publ. Math. Inst. Hautes Études Sci.* **97**, 61–179 (2003) [Zbl 1037.32013](#) [MR 2010740](#)
- [EO01] Eskin, A., Okounkov, A.: Asymptotics of numbers of branched coverings of a torus and volumes of moduli spaces of holomorphic differentials. *Invent. Math.* **145**, 59–103 (2001) [Zbl 1019.32014](#) [MR 1839286](#)
- [Gou16] Goujard, E.: Volumes of strata of moduli spaces of quadratic differentials: getting explicit values. *Ann. Inst. Fourier (Grenoble)* **66**, 2203–2251 (2016) [Zbl 1368.30020](#) [MR 3580171](#)
- [KZ95] Kaneko, M., Zagier, D.: A generalized Jacobi theta function and quasimodular forms. In: *The Moduli Space of Curves (Texel Island, 1994)*, *Progr. Math.* 129, Birkhäuser Boston, Boston, MA, 165–172 (1995) [Zbl 0892.11015](#) [MR 1363056](#)
- [KO94] Kerov, S., Olshanski, G.: Polynomial functions on the set of Young diagrams. *C. R. Acad. Sci. Paris Sér. I Math.* **319**, 121–126 (1994) [Zbl 0830.20028](#) [MR 1288389](#)

- [LZ04] Lando, S. K., Zvonkin, A. K.: *Graphs on Surfaces and Their Applications*. Encyclopaedia Math. Sci. 141, Springer, Berlin (2004) [Zbl 1040.05001](#) [MR 2036721](#)
- [Las08] Lassalle, M.: An explicit formula for the characters of the symmetric group. *Math. Ann.* **340**, 383–405 (2008) [Zbl 1182.20011](#) [MR 2368985](#)
- [Li12] Li, S.: Feynman graph integrals and almost modular forms. *Comm. Number Theory Phys.* **6**, 129–157 (2012) [Zbl 1270.81142](#) [MR 2955933](#)
- [Mil03] Milas, A.: Formal differential operators, vertex operator algebras and zeta-values. II. *J. Pure Appl. Algebra* **183**, 191–244 (2003) [Zbl 1036.17019](#) [MR 1992047](#)
- [Möl08] Möller, M.: Finiteness results for Teichmüller curves. *Ann. Inst. Fourier (Grenoble)* **58**, 63–83 (2008) [Zbl 1140.14010](#) [MR 2401216](#)
- [OO97] Okounkov, A., Olshanski, G.: Shifted Schur functions. *Algebra i Analiz* **9**, no. 2, 73–146 (1997) (in Russian) [Zbl 0894.05053](#) [MR 1468548](#)
- [OP06] Okounkov, A., Pandharipande, R.: Gromov–Witten theory, Hurwitz theory, and completed cycles. *Ann. of Math. (2)* **163**, 517–560 (2006) [Zbl 1105.14076](#) [MR 2199225](#)
- [SSZ12] Shadrin, S., Spitz, L., Zvonkine, D.: On double Hurwitz numbers with completed cycles. *J. London Math. Soc. (2)* **86**, 407–432 (2012) [Zbl 1252.05218](#) [MR 2980918](#)
- [Viv13] Viviani, F.: Tropicalizing vs. compactifying the Torelli morphism. In: *Tropical and Non-Archimedean Geometry*, Contemp. Math. 605, Amer. Math. Soc., Providence, RI, 181–210 (2013) [Zbl 1320.14018](#) [MR 3204272](#)
- [Zag91] Zagier, D.: Periods of modular forms and Jacobi theta functions. *Invent. Math.* **104**, 449–465 (1991) [Zbl 0742.11029](#) [MR 1106744](#)
- [Zag16] Zagier, D.: Partitions, quasimodular forms, and the Bloch–Okounkov theorem. *Ramanujan J.* **41**, 345–368 (2016) [Zbl 1352.05021](#) [MR 3574638](#)
- [Zor02] Zorich, A.: Square tiled surfaces and Teichmüller volumes of the moduli spaces of abelian differentials. In: *Rigidity in Dynamics and Geometry* (Cambridge, 2000), Springer, Berlin, 459–471 (2002) [Zbl 1038.37015](#) [MR 1919417](#)