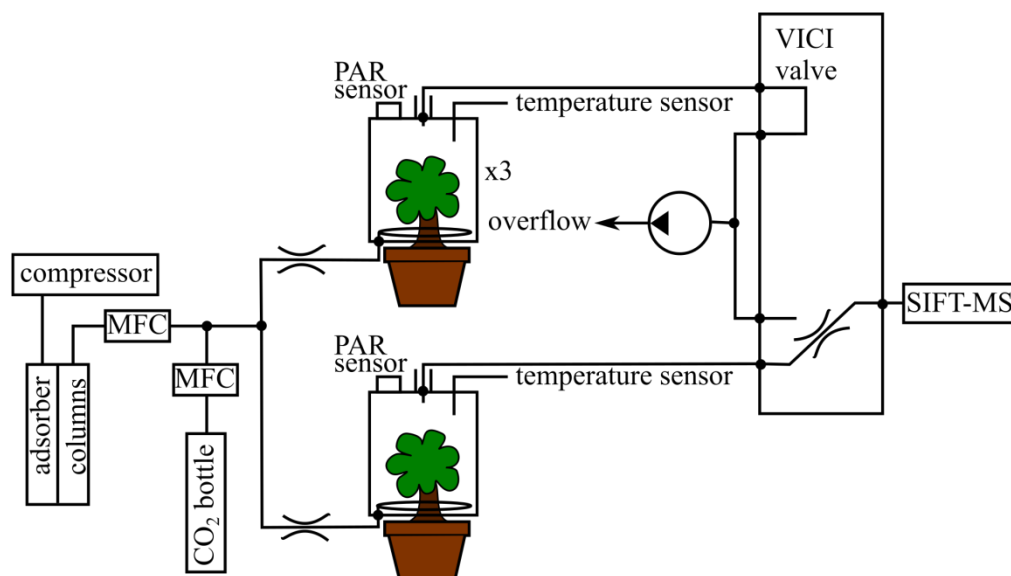


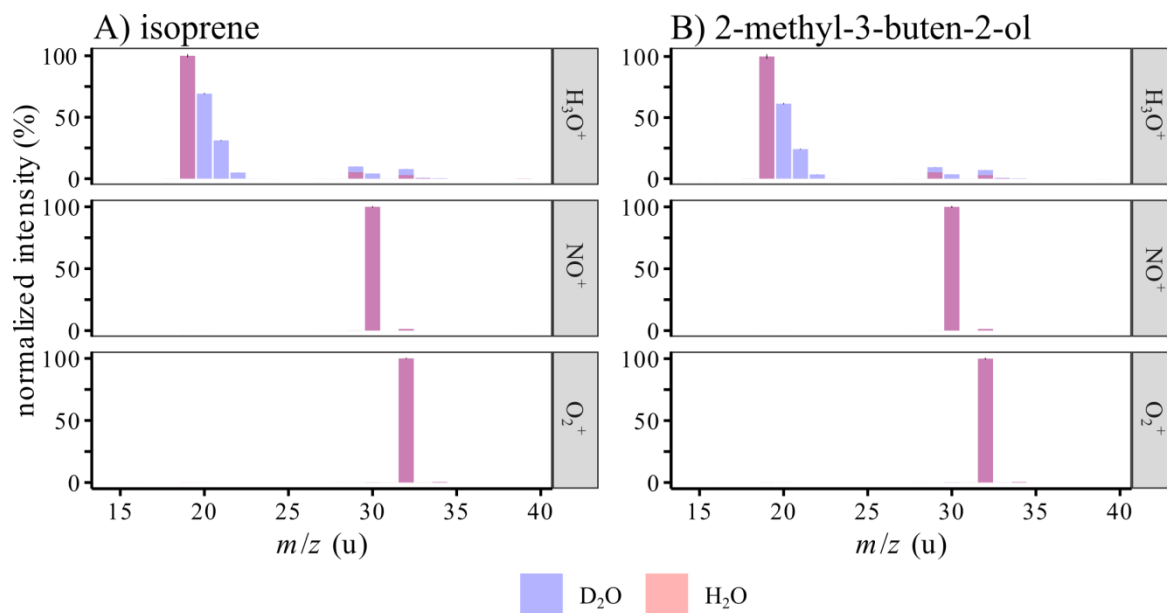
## *Supplementary Material*

**Table S1: product ions tracked in the SIM scan**

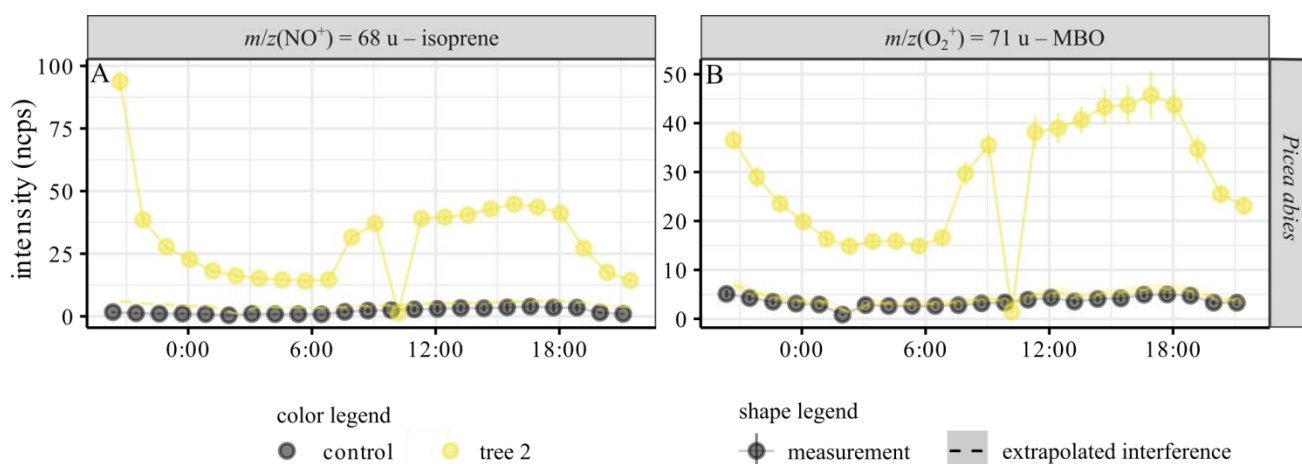
reagent ion ( $m/z$ (u))	product ion $m/z$ (u)	ion formula (substance)
$\text{H}_3\text{O}^+$ (19)	19	$\text{H}_3\text{O}^+$
	37	$\text{H}_5\text{O}_2^+$
	55	$\text{H}_7\text{O}_3^+$
	69	$\text{C}_5\text{H}_9^+$ (isoprene / MBO)
	73	$\text{H}_9\text{O}_4^+$
$\text{NO}^+$ (30)	30	$\text{NO}^+$
	48	$\text{NO}^+\cdot\text{H}_2\text{O}$
	68	$\text{C}_5\text{H}_8^+$ (isoprene)
$\text{O}_2^+$ (32)	69	$\text{C}_5\text{H}_9^+$ (MBO)
	32	$\text{O}_2^+$
	43	$\text{C}_3\text{H}_7^+$ (MBO)
	53	$\text{C}_4\text{H}_5^+$ (isoprene)
	58	$\text{C}_3\text{H}_6\text{O}^+$ (MBO)
	59	$\text{C}_3\text{H}_7\text{O}^+$ (MBO)
	67	$\text{C}_5\text{H}_7^+$ (isoprene)
	68	$\text{C}_5\text{H}_8^+$ (isoprene)
	69	$\text{C}_5\text{H}_9^+$ (MBO)
	71	$\text{C}_4\text{H}_7\text{O}^+$ (MBO)
86	$\text{C}_5\text{H}_{10}\text{O}^+$ (MBO)	



**Figure S1: Scheme of the tree chamber setup**



**Figure S2: Relative intensity of the reagent ions (normalized to the biggest intensity in the peak area) when measuring isoprene and MBO that is humidified by normal and deuterated water.**



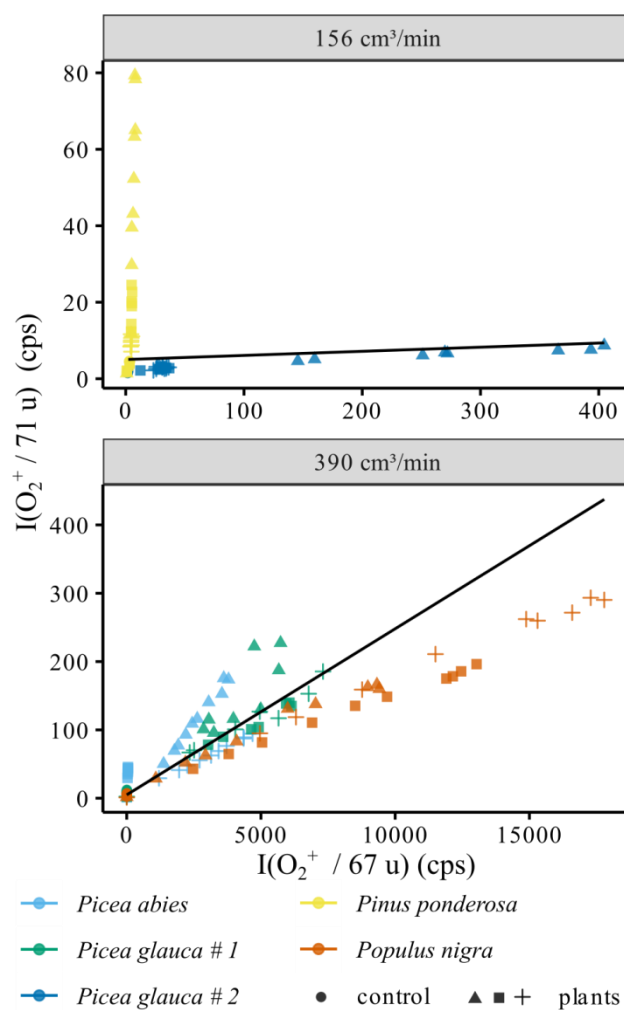
**Figure S3: Diurnal cycle of isoprene and MBO emissions of the second *Picea abies* tree (for all trees, cf. Figure 5). The measured intensities were normalized to  $10^6$  reagent ion counts. Black: control, empty chamber. Yellow: the tree, individual 2. Dots: mean  $\pm$  95% CI of the SIFT-MS measurement. A sudden Zero value indicates instrument malfunctioning (before a firmware update, software did not always switch on the VICI valve for long measurements). Dashed lines: interference extrapolated from  $m/z(\text{NO}^+) = 69$  u (MBO interference on the isoprene signal,) and  $m/z(\text{O}_2^+) = 67$  u (isoprene interference on the MBO signal) – mean  $\pm$  95% CI. Basically, if the signal at  $m/z(\text{O}_2^+) = 67$  u is isoprene, then a maximum of 1.4% (for lower carrier gas flows) and 2.9% (for higher carrier gas flows) of this signal will be seen at  $m/z(\text{O}_2^+) = 71$  u where we measure MBO. These values are represented by the dashed lines in the graphs. If the intensity of  $m/z(\text{O}_2^+) = 71$  u is higher than this signal, we also measure MBO. This also works the other way round, for MBO interference on isoprene.**

**Table S2: Needle/leaf dry weights of the three replicates of the different tree species.**

Tree species / replicate	1 ●	2 ●	3 ●
Pinus ponderosa	7.27 g	4.40 g	2.11 g
Picea abies	22.60 g	37.00 g	14.26 g
Picea glauca sp. 1	20.34 g	28.04 g	16.05 g
Picea glauca sp. 2	9.50 g	6.04 g	5.89 g
Poplar	4.05 g	6.17 g	7.39 g

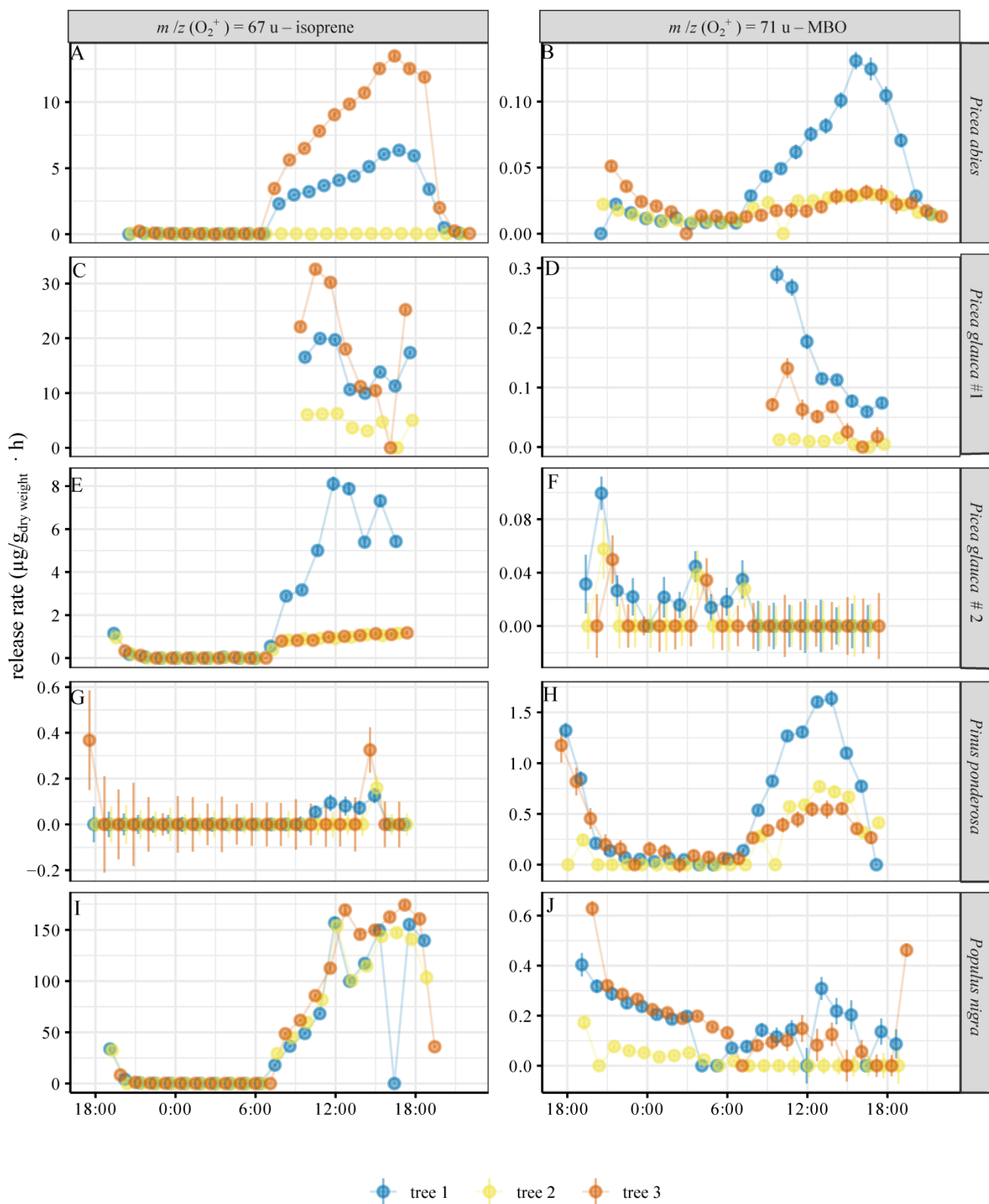
**Table S3: Air flow through the chambers.**

Chamber	1 ●	2 ●	3 ●	Control
Flow	3.2 L/min	3.5 L/min	3.5 L/min	3.4 L/min

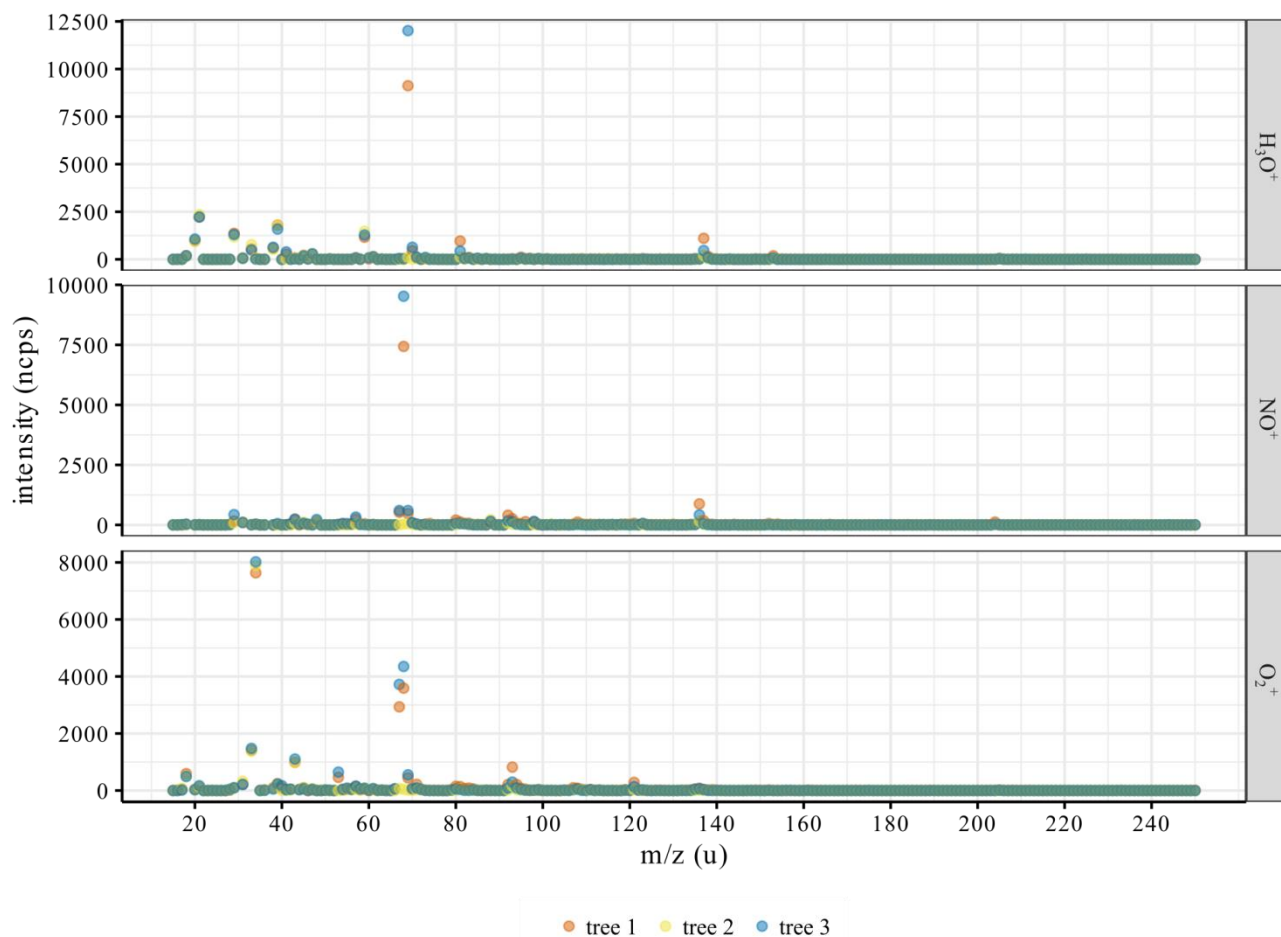


**Figure S4: Ratio of the MBO signal at  $m/z(\text{O}_2^+) = 71 \text{ u}$  versus the isoprene signal at  $m/z(\text{O}_2^+) = 67 \text{ u}$ . The black lines mark an extrapolation of the ratio calculated based on the standard measurements under humid conditions, cf. Error! Reference source not found.. Points below this range are considered to be the result of isoprene interference on the MBO signal, points above the range are considered to represent genuine MBO signals.**

**Figure S5: Isoprene and MBO emission rate in  $\mu\text{g}$  per g leaf/needle dry weight per hour (mean  $\pm$  95% CI) for the five different tree species evaluated. The extrapolated interference background was subtracted before calculating the emission rates.**



**Figure S6: Isoprene and MBO emission rate in  $\mu\text{g}$  per  $\text{g}$  leaf/needle dry weight per hour (mean  $\pm$  95% CI) for the five different tree species evaluated. Both are based on their signals upon reaction with  $\text{O}_2^+$ . The extrapolated interference background was subtracted before calculating the emission rates.**



**Figure S7: SIFT-MS mass spectra of the three *P. abies* trees at 3 pm (where the emissions are highest in this tree). The intensities are normalized to  $10^6$  reagent ion counts. Since only one spectrum was measured, no error bars could be calculated.  $m/z = 19, 30, 32, 37$  u (the reagent ions) are not shown due to their high intensity. Monoterpenes as sum parameter can be measured on  $m/z(\text{H}_3\text{O}^+) = 137$  u,  $m/z(\text{NO}^+) = 136$  u, and  $m/z(\text{O}_2^+) = 136$  u, sesquiterpenes on  $m/z(\text{H}_3\text{O}^+) = 205$  u,  $m/z(\text{NO}^+) = 204$  u, and  $m/z(\text{O}_2^+) = 204$  u.**