

RESEARCH ARTICLE

A 3-categorical perspective on G -crossed braided categories

Corey Jones¹ | David Penneys² | David Reutter³

¹Department of Mathematics, North Carolina State University, Raleigh, North Carolina, USA

²Department of Mathematics, The Ohio State University, Columbus, Ohio, USA

³Fachbereich Mathematik, Universität Hamburg, Hamburg, Germany

Correspondence

David Penneys, Department of Mathematics, The Ohio State University, 100 Math Tower, 231 West 18th Ave, Columbus, OH 43210-1174, USA.
Email: penneys.2@osu.edu

Funding information

National Science Foundation, Grant/Award Numbers: DMS-1440140, 1901082, 1654159; Max Planck Institute for Mathematics

Abstract

A braided monoidal category may be considered a 3-category with one object and one 1-morphism. In this paper, we show that, more generally, 3-categories with one object and 1-morphisms given by elements of a group G correspond to G -crossed braided categories, certain mathematical structures which have emerged as important invariants of low-dimensional quantum field theories. More precisely, we show that the 4-category of 3-categories C equipped with a 3-functor $BG \rightarrow C$ which is essentially surjective on objects and 1-morphisms is equivalent to the 2-category of G -crossed braided categories. This provides a uniform approach to various constructions of G -crossed braided categories.

MSC 2020

18N20 (primary), 18M15, 18M30 (secondary)

1 | INTRODUCTION

G -crossed braided categories [22, section 8.24] (see also Subsection 4.1) have emerged as important mathematical structures describing symmetry enriched invariants of quantum field theories in low dimensions. In particular, G -crossed braided categories arise from global symmetries in (1+1)D chiral conformal field theory [43, 44, 49] and (2+1)D topological phases of matter [3], and as invariants of 3-dimensional homotopy quantum field theories [52, 53]. They are a central object of study in the theory of G -extensions of fusion categories [16, 23, 29]. In this article, we describe a higher categorical approach to G -crossed braided categories, which unifies these perspectives.

© 2022 The Authors. *Journal of the London Mathematical Society* is copyright © London Mathematical Society. This is an open access article under the terms of the [Creative Commons Attribution-NonCommercial-NoDerivs](https://creativecommons.org/licenses/by-nc-nd/4.0/) License, which permits use and distribution in any medium, provided the original work is properly cited, the use is non-commercial and no modifications or adaptations are made.

When G is trivial, a G -crossed braided category is exactly a braided monoidal category. It is well-known that braided monoidal categories are ‘the same as’ 3-categories[†] with exactly one object and one 1-morphism [1, table 21] and [14]. This is an instance of the *Delooping Hypothesis* [2, section 5.6 and Hypothesis 22] relating k -fold degenerate $(n + k)$ -categories with k -fold monoidal n -categories. However, twice degenerate 3-categories, 3-functors, transformations, modifications, and perturbations form a 4-category, whereas braided monoidal categories, braided monoidal functors, and monoidal natural transformations only form a 2-category. This discrepancy can be resolved by viewing ‘2-fold degeneracy’ as a *structure* on a 3-category rather than a *property*, namely, the structure of a 1-surjective pointing[‡] [2, section 5.6]. Explicitly, the Delooping Hypothesis may then be understood as asserting that the 4-category of 3-categories equipped with 1-surjective pointings and pointing-preserving higher morphisms between them is in fact a 2-category (all hom 2-categories between 2-morphisms are contractible) and is equivalent to the 2-category of braided monoidal categories.

Rather than pointing by something contractible (that is, a point), we can also study ‘pointings’ by other categories. In this article, we show that 1-surjective G -pointed 3-categories, that is, 3-categories equipped with a 1-surjective 3-functor from a group G viewed as a 1-category BG with one object, are ‘the same as’ G -crossed braided categories.

Theorem A. *The 4-category[§] 3Cat_G of 1-surjective G -pointed 3-categories and pointing-preserving higher morphisms (see Definition 3.2) is equivalent to the 2-category $G\text{CrBrd}$ of G -crossed braided categories. In particular, every hom 2-category between parallel 2-morphisms in 3Cat_G is contractible.*

We prove Theorem A as follows. First, we show in Theorem 3.4 and Corollary 3.5 that 3Cat_G is 2-truncated by showing it is equivalent to the *strict* sub-2-category $3\text{Cat}_G^{\text{st}}$ of *strict* G -pointed 3-categories, whose objects are Gray-categories with precisely one object, whose sets of 1-morphisms are exactly G , and composition of 1-morphisms is the group multiplication. Then in Theorem 4.1, we construct a strict 2-equivalence between $3\text{Cat}_G^{\text{st}}$ and the strict 2-category $G\text{CrBrd}^{\text{st}}$ of strict G -crossed braided categories. Finally, by [27], every G -crossed braided category is equivalent to a strict one (see Definition 4.7 for more details), so that $G\text{CrBrd}$ is equivalent to its full 2-subcategory $G\text{CrBrd}^{\text{st}}$. In summary, we construct the following zig-zag of strict equivalences, where the hooked arrows denote inclusions of full subcategories.

$$3\text{Cat}_G \xleftarrow[\text{Thm. 3.4}]{\sim} 3\text{Cat}_G^{\text{st}} \xrightarrow[\text{Thm. 4.1}]{\sim} G\text{CrBrd}^{\text{st}} \xleftarrow[\text{[27]}]{\sim} G\text{CrBrd} \quad (1)$$

For the trivial group $G = \{e\}$, Theorem A specializes to the Delooping Hypothesis for twice degenerate 3-categories (also see [14], which uses so called ‘iconic natural transformations’ rather than pointings).

[†] In this article, by a 3-category we mean an algebraic tricategory in the sense of [35, Definition 4.1], and by *functor*, *transformation*, *modification*, and *perturbation*, we mean the corresponding notions of trihomomorphism, tritransformation, trimodification, and perturbation of [35, Definitions 4.10, 4.16, 4.18, and 4.21].

[‡] A functor between n -categories $\mathcal{G} \rightarrow \mathcal{C}$ is k -surjective if it is essentially surjective on objects and on j -morphisms for all $1 \leq j \leq k$. A k -surjective pointing on an n -category \mathcal{C} is a k -surjective functor $* \rightarrow \mathcal{C}$.

[§] The statement of Theorem A assumes the existence of such a 4-category, which to our knowledge has not been established. The proof, however, requires only an interlocking system of 2-categories, and all of our results can be stated and proven at the level of 2-categories. See Remark 3.3 for more details.

Corollary B. *The 4-category³ $3\text{Cat}_{\{e\}}$ of 1-surjective pointed 3-categories is equivalent to the 2-category of braided monoidal categories.*

Our main theorem was inspired by, and is closely related to, the following two results: Passing from a G -pointed 3-category to the associated G -crossed braided category generalizes a result of [10] which constructs G -crossed braided categories from group actions on 2-categories; see Example 1.11 for more details. A version of the construction of a G -pointed 3-category from a G -crossed braided category is discussed in [15], and we use this construction in Subsection 4.3 to prove essential surjectivity of the 2-functor $3\text{Cat}_G^{\text{st}} \rightarrow \text{GCrsBrd}^{\text{st}}$.

Our construction may be understood as a non-invertible generalization of the homotopy fiber. Indeed, part of the data of a G -crossed braided category is a G -graded monoidal category. Given a 1-surjective functor $BG \rightarrow C$ where C is a (pointed connected) 3-groupoid, the homotopy fiber $X \rightarrow BG \rightarrow C$ at the basepoint of C is a pointed connected 2-groupoid with a map to BG , or equivalently, a G -graded monoidal groupoid in which all objects are tensor invertible. The G -action and the G -crossed braiding arise as ‘delooping data’ which identify the map $X \rightarrow BG$ as a homotopy fiber.

1.1 | G -crossed braided categories from G -pointed 3-categories

In the proof of Theorem A, we construct the equivalence $3\text{Cat}_G \sim \text{GCrsBrd}$ by passing through appropriate strictifications, resulting in the zig-zag (1) of strict equivalences. For the reader’s convenience, we now sketch a direct construction of a G -crossed braided category (defined in Section 4) from a G -pointed 3-category, without passing through strictifications.

For a group G , we denote by BG the *delooping* of G , that is, G considered as a 1-category with one object. Let C be a 3-category equipped with a 3-functor[†] $\pi : BG \rightarrow C$.

To construct the G -crossed braided category, we will make use of the graphical calculus of Gray-categories (outlined in Subsection 2.2) and hence assume that C has been strictified to a Gray-category.[‡] Unpacking the (weak) 3-functor into the data $(\pi, \mu^\pi, \iota^\pi, \omega^\pi, \lambda^\pi, \rho^\pi)$ as described in Appendix A, the G -crossed braided category \mathfrak{C} may be constructed as follows. Strictifying the situation slightly, we may assume that C has only one object, that is, is a Gray-monoid, a monoid object in Gray viewed as a monoidal 2-category, and that the underlying 2-functor of π is strict (the unitor and compositor data π^1, π^2 of π is trivial).

We write $g_C := \pi(g) \in C$, and we define $\mathfrak{C}_g := C(1_C \rightarrow g_C)$ for each $g \in G$. We denote the tensorator $\mu_{g,h}^\pi \in C(g_C \otimes h_C \rightarrow gh_C)$ and unitor $\iota_*^\pi \in C(1_C \rightarrow e_C)$ of π by trivalent and univalent vertices, respectively,

$$\mu_{g,h}^\pi = \begin{array}{c} gh_C \\ | \\ \bullet \\ / \quad \backslash \\ g_C \quad h_C \end{array} \qquad \iota_*^\pi = \begin{array}{c} e_C \\ | \\ \bullet \end{array} .$$

[†] Since a k -category may be viewed as an n -category for $n \geq k$ with only identity r -morphism for $n \geq r > k$, it makes sense to talk about an n -functor from a k -category to an n -category.

[‡] In fact, [36] justifies working with this graphical calculus even in the context of weak 3-categories.

We denote 1-morphisms $a_g \in \mathcal{C}(1_C \rightarrow g_C)$ by shaded disks as follows:

$$a_g = \begin{array}{c} g_C \\ \circ \end{array} \quad b_h = \begin{array}{c} h_C \\ \bullet \end{array} \quad c_k = \begin{array}{c} k_C \\ \bullet \end{array} .$$

For $g, h \in G$, we define a tensor product $(a_g, b_h) \mapsto a_g \otimes b_h$ by

$$\begin{array}{c} g_C \\ \circ \end{array} \times \begin{array}{c} h_C \\ \bullet \end{array} \mapsto \begin{array}{c} gh_C \\ \circ \end{array} , \tag{2}$$

and we define the associator $\otimes_{g,h,k} \circ (\otimes_{g,h} \times \mathfrak{C}_k) \Rightarrow \otimes_{g,hk} \circ (\mathfrak{C}_g \times \otimes_{h,k})$ by

$$\begin{array}{c} ghk_C \\ \circ \end{array} \xRightarrow{\omega_{g,h,k}^\pi} \begin{array}{c} ghk_C \\ \circ \end{array} \xRightarrow{\phi^{-1}} \begin{array}{c} ghk_C \\ \circ \end{array} , \tag{3}$$

where ϕ denotes the interchanger in \mathcal{C} (see Section 2). We define the unit object $1_{\mathfrak{C}} := \iota_*^\pi \in \mathfrak{C}_e$. Unitors $\otimes_{e,g} \circ (i \times -) \Rightarrow \text{id}_{\mathfrak{C}_g}$ and $\otimes_{g,e} \circ (- \times i) \Rightarrow \text{id}_{\mathfrak{C}_g}$ are given, respectively, by

$$\begin{array}{c} g_C \\ \circ \end{array} \xRightarrow{\lambda_g^\pi} \begin{array}{c} g_C \\ \circ \end{array} \quad \text{and} \quad \begin{array}{c} g_C \\ \circ \end{array} \xRightarrow{\phi} \begin{array}{c} g_C \\ \circ \end{array} \xRightarrow{\rho_g^\pi} \begin{array}{c} g_C \\ \circ \end{array} .$$

We define a G -action $F_g : \mathfrak{C}_h \rightarrow \mathfrak{C}_{ghg^{-1}}$ by

$$F_g \left(\begin{array}{c} h_C \\ \bullet \end{array} \right) := \begin{array}{c} ghg^{-1}_C \\ \circ \end{array} . \tag{4}$$

The functors F_g come equipped with natural isomorphisms $\psi^g : \otimes_{ghg^{-1},gkg^{-1}} \circ (F_g \times F_g) \Rightarrow F_g \circ \otimes_{h,k}$ built from the coherence isomorphisms $\omega^\pi, \lambda^\pi, \rho^\pi$ and interchangers between two black nodes and between a black node and a shaded disk. For example, ψ_{b_h, c_k}^g is given by

$$\begin{array}{c} \text{Diagram 1} \end{array} \xRightarrow{\phi} \begin{array}{c} \text{Diagram 2} \end{array} \xRightarrow{\omega_{\lambda, \rho}} \begin{array}{c} \text{Diagram 3} \end{array} \xRightarrow{\phi} \begin{array}{c} \text{Diagram 4} \end{array} \xRightarrow{\omega_{\lambda, \rho}} \begin{array}{c} \text{Diagram 5} \end{array} \xRightarrow{\omega_{\lambda, \rho}} \begin{array}{c} \text{Diagram 6} \end{array} . \tag{5}$$

The tensorator $\mu_{g,h} : F_g \circ F_h \Rightarrow F_{gh}$ and the unit map $\iota_h : \text{id}_{\mathcal{C}_h} \rightarrow F_e|_{\mathcal{C}_h}$ are defined similarly. The G -crossed braiding natural isomorphisms $\beta^{g,h} : a_g \otimes b_h \rightarrow F_g(b_h) \otimes a_g$ are also defined similarly using the interchanger isomorphism ϕ of \mathcal{C} :

1.2 | The delooping hypothesis

Recall $(n + k)$ -categories form an $(n + k + 1)$ -category, whereas k -fold monoidal n -categories only form an $(n + 1)$ -category. Thus, one should not think of ‘ k -fold degeneracy’ as a *property* of an $(n + k)$ -category \mathcal{C} but rather as additional *structure*, namely, the structure of a $(k - 1)$ -surjective pointing, and require all morphisms and higher morphisms between these categories to preserve pointings [2, section 5.6]. Explicitly, the Delooping Hypothesis may then be understood as asserting that $(k - 1)$ -connected pointed $(n + k)$ -categories and pointing-preserving higher morphisms form an $(n + 1)$ -category which is equivalent to the $(n + 1)$ -category of k -fold monoidal n -categories. This is an instance of a more general higher categorical principle.

Definition 1.1. We call a functor $F : \mathcal{C} \rightarrow \mathcal{D}$ of n -categories k -surjective[†] if it is essentially surjective on objects and parallel r -morphisms for $r \leq k$. By convention, any functor is (-1) -surjective.

Hypothesis 1.2. Let \mathcal{G} be a n -category. The full $(n + 1)$ -subcategory of the under- $(n + 1)$ -category $n\text{Cat}_{\mathcal{G}}$ on the k -surjective functors out of \mathcal{G} is an $(n - k)$ -category, that is, all hom $(k + 1)$ -categories between parallel $(n - k)$ -morphisms are contractible.

Remark 1.3. We expect hypothesis 1.2 is a direct consequence of more common assumptions on the $(n + 1)$ -category of n -categories: Namely, following [2, section 5.5], we say that a functor $F : \mathcal{C} \rightarrow \mathcal{D}$ between n -categories is j -monic[‡] if it is essentially surjective on k -morphisms for all $k > j$ (including $k = n + 1$, where we interpret surjectivity to mean faithfulness on n -morphisms). By [2, Hypothesis 17], the (weak) fibers of such a j -monic functor are expected to be (possibly

[†] This notion of k -surjectivity does not coincide with the one used in [2], where a functor is said to be k -surjective if it is essentially surjective on k -morphisms.

[‡] Many of the definitions and statements in this remark are extensively developed in the setting of $(\infty, 1)$ -categories [46, section 5], and in particular in the $(n + 1, 1)$ -category of n -categories. However, we are not able to use these $(\infty, 1)$ -notions and statements for our purposes, as we are working in the $(n + 1, n + 1)$ -category of n -categories. For example, our j -monomorphisms do not coincide with the $(\infty, 1)$ -categorical j -monomorphisms (in this context also known as $(j - 1)$ -truncated morphisms) as the latter only fulfill essential surjectivity conditions with respect to invertible cells.

	\mathcal{G}	$n + k = 0$	$n + k = 1$	$n + k = 2$	$n + k = 3$
$k = -1$	\emptyset	0-category	1-category	2-category	3-category
$k = 0$	$*$	point	monoid	monoidal category	monoidal 2-category
$k = 1$	BG		normal subgroup of G	G -crossed monoid	G -crossed braided category

FIGURE 1 $(n + k)$ -Categories equipped with k -surjective functors from \mathcal{G} form an n -category

poset-enriched) $(j - 1)$ -categories.[†] Dually, a functor $G : C \rightarrow D$ between n -categories is j -epic if for every n -category \mathcal{E} , the pre-composition functor $n\text{Cat}(p, \mathcal{E}) : n\text{Cat}(D \rightarrow \mathcal{E}) \rightarrow n\text{Cat}(C \rightarrow \mathcal{E})$ is $(n - 1 - j)$ -monic. In particular, any j -surjective functor in the sense of Definition 1.1 is j -epic.[‡] Combining these observations, given a k -surjective functor $p : \mathcal{G} \rightarrow C$ and an n -category \mathcal{E} , the pre-composition functor $n\text{Cat}(p, \mathcal{E}) : n\text{Cat}(C \rightarrow \mathcal{E}) \rightarrow n\text{Cat}(\mathcal{G} \rightarrow \mathcal{E})$ is $(n - 1 - k)$ -monic. Hence, its fiber at a $g \in n\text{Cat}(\mathcal{G} \rightarrow \mathcal{E})$ is a (possibly poset-enriched) $(n - 1 - k)$ -category. But the fiber of the pre-composition functor $n\text{Cat}(p, \mathcal{E})$ at $g : \mathcal{G} \rightarrow \mathcal{E}$ is the hom-category $n\text{Cat}_{\mathcal{G}}(g, p)$ of the under-category of n -categories under \mathcal{G} . Therefore, the full subcategory of $n\text{Cat}_{\mathcal{G}}$ on the k -surjective functors is a (possibly poset-enriched) $(n - k)$ -category. Moreover, essential (0-)surjectivity of $p : \mathcal{G} \rightarrow C$ (also cf. footnote) should imply that the pre-composition functor $n\text{Cat}(p, \mathcal{E}) : n\text{Cat}(C \rightarrow \mathcal{E}) \rightarrow n\text{Cat}(\mathcal{G} \rightarrow \mathcal{E})$ is n -conservative[§], and hence that the enriching posets of the (weak) fibers of $n\text{Cat}(p, \mathcal{E})$ are honest sets.

Example 1.4 (k -fold monoidal n -categories). In the case where $\mathcal{G} = *$ is the terminal category, Hypothesis 1.2 asserts that $(k - 1)$ -surjective (k -fold degenerate) pointed $(n + k)$ -categories form an $(n + 1)$ -category. The Delooping Hypothesis [2, section 5.6 and Hypothesis 22] identifies this $(n + 1)$ -category with the $(n + 1)$ -category of k -fold monoidal n -categories.

An important consequence of Hypothesis 1.2 is that it allows us to study certain higher categorical objects, namely, k -surjective functors and their higher transformations, using lower categorical machinery. In many instances, there exist concrete descriptions of the resulting low-dimensional categories which have been developed and appear in mathematics and physics independently.

As a concrete example, it is easier to describe and work with the 1-category of monoids and monoid homomorphisms than its unpointed variant, the 2-category of categories, functors, and natural transformations. Similarly, it is easier to describe and work with the 2-category of monoidal categories, monoidal functors, and monoidal natural transformations than its unpointed variant, the 3-category of 2-categories, 2-functors, 2-transformations, and 2-modifications. Similar examples are shown in Figure 1.

In this article, we focus on 1-surjective functors from the delooping BG of G , that is, the 1-category with one object and endomorphisms G .

[†] A functor between n -groupoids is j -monic if and only if its fibers are $(j - 1)$ -categories. For functors between general n -categories, j -monomorphisms have truncated fibers but the converse is not necessarily true.

[‡] More generally, j -surjective functors are expected to correspond to ‘strong j -epimorphisms’ [2, Hypothesis 21], that is, functors that have the left lifting property with respect to j -monomorphisms. Since the $(n + 1)$ -category of n -categories has finite limits, any such ‘strong j -epimorphism’ is in particular a j -epimorphism; see [2, section 5.5].

[§] An n -functor $F : C \rightarrow D$ is n -conservative if it reflects n -isomorphisms, that is, for every n -morphism $\alpha : f \Rightarrow g$ in C for which $F(\alpha)$ is an isomorphism, it follows that α is an isomorphism.

Hypothesis 1.5 (G -crossed delooping). For $n \geq -1$, the $(n + 3)$ -category of 1-surjective functors from BG into $(n + 2)$ -categories is equivalent to the $(n + 1)$ -category of G -crossed braided n -categories.

While we do not present a general definition of G -crossed braided n -category here, this hypothesis is a desideratum for any such definition (such as, for example, via Müller and Woike’s ‘little bundles’ operad [50]). Observe that the $k = 1$ version of the delooping hypothesis follows as a consequence for the trivial group $G = \{e\}$.

In the following, as a warm-up to our main theorem, we discuss the low-dimensional versions ($n = 0$ and $n = -1$) of Hypothesis 1.5 appearing in the last row of Figure 1.

Example 1.6 (G -crossed monoids as G -pointed 2-categories). The 3-category 2Cat_G of 2-categories C equipped with 1-surjective 2-functors $BG \rightarrow C$ is equivalent to the 1-category of G -crossed monoids, or ‘ G -crossed braided 0-categories’, defined below. Explicitly, the 2-category 2Cat_G has

- objects (C, π^C) where C is a 2-category and $\pi^C : BG \rightarrow C$ is a 1-surjective 2-functor,
- 1-morphisms $(A, \alpha) : (C, \pi^C) \rightarrow (D, \pi^D)$ where $A : C \rightarrow D$ is a 2-functor and $\alpha : \pi^D \Rightarrow A \circ \pi^C$ is an invertible 2-transformation,
- 2-morphisms $(\eta, m) : (A, \alpha) \Rightarrow (B, \beta)$ where $\eta : A \Rightarrow B$ is a 2-transformation

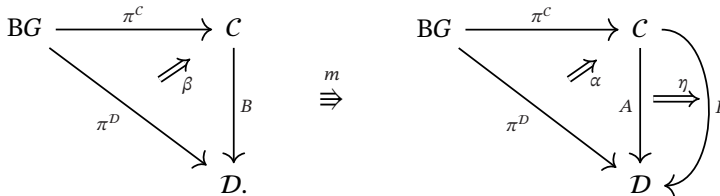

- 3-morphisms $p : (\eta, m) \Rightarrow (\zeta, n)$ where $p : \eta \Rightarrow \zeta$ is a 2-modification such that

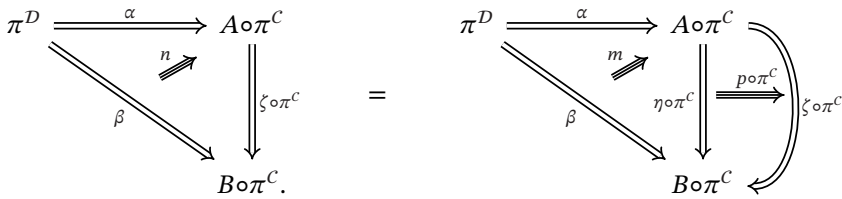

On the other hand, a natural decategorification of a G -crossed braided monoidal category is a G -graded monoid $M = \prod_{g \in G} M_g$ together with a group homomorphism $\pi^M : G \rightarrow \text{Aut}(M)$ such that the following axioms are satisfied:

- $\pi_g^M(m_h) \in M_{ghg^{-1}}$ for all $g \in G$ and $m_h \in M_h$, and
- $m_g \cdot n_h = \pi_g^M(n_h) \cdot m_g$ for all $m \in M_g$ and $n_h \in M_h$.

We call such a pair (M, π^M) a G -crossed monoid, or a ‘ G -crossed braided 0-category’. Morphisms $(M, \pi^M) \rightarrow (N, \pi^N)$ are G -graded monoid homomorphisms that intertwine the G -actions.

To see that 2Cat_G is equivalent to the category of G -crossed monoids, we mirror our proof of Theorem A. One first shows that 2Cat_G is equivalent to the 1-category $2\text{Cat}_G^{\text{st}}$ with

- objects strict monoidal categories C whose set of objects is $\{g_C\}_{g \in G}$ with $1_C = e_C$ and tensor product given by the group multiplication, and

- morphisms $A : C \rightarrow D$ are strict monoidal functors such that $A(g_C) = g_D$ for all $g \in G$.

The equivalence from $2\text{Cat}_G^{\text{st}}$ to G -crossed monoids is given by taking hom from 1_C . We set $M_g := C(1_C \rightarrow g_C)$, and the multiplication on $M := \coprod_{g \in G} M_g$ is \otimes in C . The G -action $\pi^M : G \rightarrow \text{Aut}(M)$ is given by conjugation:

$$\pi_g^M(m_h) := \text{id}_{g_C} \otimes m_h \otimes \text{id}_{g_C^{-1}} \in M_{ghg^{-1}} = C(1_C \rightarrow ghg^{-1}).$$

One then verifies the G -crossed braiding axiom by a G -graded version of Eckmann-Hilton. A 1-morphism $A \in 2\text{Cat}_G^{\text{st}}(C \rightarrow D)$ yields a G -graded monoid homomorphism by restricting to $M_g = C(1_C \rightarrow g_C)$. This monoid homomorphism is compatible with the G -actions by strictness of A . Finally, one verifies this construction is an equivalence of categories.

Example 1.7 (Normal subgroups as G -pointed 1-categories). The 2-category Cat_G of 1-categories C equipped with 1-surjective functors $BG \rightarrow C$ is equivalent to the set of normal subgroups of G (which we may think of as the ‘0-category of G -crossed braided (-1) -categories’, see below). Explicitly, Cat_G has

- objects (C, π^C) where C is a category and $\pi^C : BG \rightarrow C$ is a 1-surjective functor,
- 1-morphisms $(A, \alpha) : (C, \pi^C) \rightarrow (D, \pi^D)$ where $A : C \rightarrow D$ is a functor and $\alpha : \pi^D \Rightarrow A \circ \pi^C$ is a natural isomorphism, and
- 2-morphisms $\eta : (A, \alpha) \Rightarrow (B, \beta)$ are natural transformations $\eta : A \Rightarrow B$ such that

It is straightforward to verify that this 2-category is equivalent to a set. Moreover, up to equivalence, the data of a 1-surjective functor $\pi^C : BG \rightarrow C$ are equivalent to the data of a normal subgroup of G , obtained as the kernel of the surjective group homomorphism $G \rightarrow \text{Aut}_C(\pi^C(*))$. Hence, the 2-category Cat_G is equivalent to the set of normal subgroups of G .

Employing ‘categorical negative thinking’ as in [2, section 2], we may in fact think of a normal subgroup of G as a ‘ G -crossed braided (-1) -category’, and hence of the set of normal subgroups as ‘the 0-category of G -crossed braided (-1) -category’ as it appears in Hypothesis 1.5: Since a (-1) -category may be thought of as a truth value [2, section 2], one may define a G -graded (-1) -category to be a monoid homomorphism $G \rightarrow \text{Bool} = (\{T, F\}, \wedge)$, where Bool denotes the Booleans which one may think of as the commutative monoid (symmetric monoidal 0-category) of (-1) -categories. Indeed, by taking the kernel, such ‘ G -graded (-1) -categories’ correspond to normal subgroups of G . This correspondence may be seen a further decategorified analogue of our construction. Indeed, given (C, π^C) , the corresponding monoid homomorphism $G \rightarrow \text{Bool}$ is exactly given by $g \mapsto C(\text{id}_{\pi^C(*)} \rightarrow \pi^C(g))$, where the latter is the Boolean which is true if $\text{id}_{\pi^C(*)} = \pi(g)$ and false otherwise.

Example 1.8 (Shaded monoidal algebras). In [32, Definitions 3.18 and 3.26], the authors define the notion of a shaded monoidal algebra, which is an operadic approach to 2-categories with a

chosen set of objects and a set of generating 1-morphisms. The statements of [32, Theorem 3.21 and Corollary 3.23] can be understood as examples of Hypothesis 1.2. Indeed, equipping a 2-category with a set of objects and a generating set of 1-morphisms is equivalent to pointing by the free category on a graph Γ . Hence, the 3-category of 1-surjective Γ -pointed 2-categories is equivalent to the 1-category of Γ -shaded monoidal algebras.

Remark 1.9 (Planar algebras). Expanding on Example 1.8, Jones' planar algebras [41] reflect the philosophy of Hypothesis 1.2. A 2-shaded planar algebra may be understood as a pivotal 2-category C with precisely two objects 'unshaded' and 'shaded' together with a generating dualizable 1-morphism between them with loop modulus δ . This choice of generating 1-morphism may be understood as equipping C with a 1-surjective pivotal functor $\pi^C : \mathcal{T}\mathcal{L}\mathcal{J}(\delta) \rightarrow C$, where $\mathcal{T}\mathcal{L}\mathcal{J}(\delta)$ is the free spherical 2-category on a dualizable 1-morphism with quantum dimension δ . By (a pivotal version of) Hypothesis 1.2, such pivotal 2-categories and functors preserving this 'TLJ-pointing' actually form a 1-category, which is equivalent to the 1-category of 2-shaded planar algebras and planar algebra homomorphisms.

Another instance of this philosophy appears in [38] which shows the 2-category ModTens_* of pointed module tensor categories over a braided pivotal category \mathcal{V} (defined in [38, section 3.1]) is 1-truncated [38, Lemma 3.6]. By [38, Theorem A], ModTens_* is equivalent to the 1-category of anchored planar algebras in \mathcal{V} .

1.3 | Examples

Our main theorem asserts an equivalence between 1-surjective functors $BG \rightarrow C$ and G -crossed braided categories. Starting with an arbitrary 3-functor $\pi : BG \rightarrow C$ we may factor it through a 1-surjective functor $\pi' : BG \rightarrow C'$ (where C' is the subcategory of C with objects and 1-morphisms in the essential image of π , and all 2- and 3-morphisms between them) and apply our construction from Subsection 1.1 to obtain a G -crossed braided category. Most examples discussed below arise in this way.

Example 1.10 (Delooped braided monoidal categories). Let \mathcal{B} be a braided monoidal category, and denote the corresponding 3-category with one object and one 1-morphism by $B^2\mathcal{B}$. Observe that every weak 3-functor $BG \rightarrow B^2\mathcal{B}$ is automatically 1-surjective. Such 3-functors $BG \rightarrow B^2\mathcal{B}$ factor through the maximal sub-3-groupoid $B^2\mathcal{B}^\times$ of $B^2\mathcal{B}$, delooping the braided monoidal groupoid \mathcal{B}^\times of invertible objects and morphisms in \mathcal{B} . By the homotopy hypothesis for algebraic trigroupoids,[†] such functors correspond to homotopy classes of maps from the classifying space BG to the 1-connected homotopy 3-type $B^2\mathcal{B}^\times$.

Such 1-connected 3-types are completely determined by the abelian group $\pi_2(B^2\mathcal{B}^\times) = \text{Inv}(\mathcal{B})$ of isomorphism classes of invertible objects of \mathcal{B} , the abelian group $\pi_3(B^2\mathcal{B}^\times) = \text{Aut}(1_{\mathcal{B}})$ of auto-morphisms of the tensor unit $1_{\mathcal{B}}$ of \mathcal{B} , and the k -invariant $q \in H^4(K(\text{Inv}(\mathcal{B}), 2), \text{Aut}(1_{\mathcal{B}})) \cong$

[†] The homotopy hypothesis for algebraic trigroupoids asserts that the 1-category of algebraic trigroupoids and natural equivalence classes of weak 3-functors is equivalent to the category of homotopy 3-types and homotopy classes of continuous maps. Indeed, the article [45] constructs a model category structure on the category of Gray-categories and Gray-functors which restricts to a model structure on Gray-groupoids, whose corresponding homotopy category is equivalent to the homotopy category of 3-types. Finally, it is shown in [24] that this homotopy category of Gray-groupoids is equivalent to the category of algebraic trigroupoids and natural equivalence classes of weak 3-functors.

$\text{Quad}(\text{Inv}(\mathcal{B}), \text{Aut}(1_{\mathcal{B}}))$, the group of quadratic functions on $\text{Inv}(\mathcal{B})$ valued in $\text{Aut}(1_{\mathcal{B}})$ [21], which is explicitly given by the quadratic function

$$q : \text{Inv}(\mathcal{B}) \rightarrow \text{Aut}(1_{\mathcal{B}}) \quad \text{given by} \quad q(b) := \text{ev}_b \circ \beta_{b,b^{-1}}^{\mathcal{B}} \circ \text{coev}_b.$$

Here, $\text{ev}_b : b^{-1} \otimes b \rightarrow I$ and $\text{coev}_b : I \rightarrow b \otimes b^{-1}$ denote a choice of pairing between b and b^{-1} and $\beta_{b,b^{-1}} : b \otimes b^{-1} \rightarrow b^{-1} \otimes b$ denotes the braiding.

By [21, 48], the group $\text{Quad}(\text{Inv}(\mathcal{B}), \text{Aut}(1_{\mathcal{B}}))$ is further isomorphic to the group $H^3_{ab}(\text{Inv}(\mathcal{B}), \text{Aut}(1_{\mathcal{B}}))$ of *abelian 3-cocycles* (α, β) , consisting of pairs of a group 3-cocycle $\alpha : \text{Inv}(\mathcal{B})^3 \rightarrow \text{Aut}(1_{\mathcal{B}})$ and a certain ‘ α -twisted-bilinear’ form $\beta : \text{Inv}(\mathcal{B})^2 \rightarrow \text{Aut}(1_{\mathcal{B}})$. We refer the reader to [11, (1.2) and section 11] for more details.

By the obstruction theory for homotopy classes of maps into such Postnikov towers (cf. [23, Theorem 1.3]), it follows that, up to natural isomorphism, 3-functors $BG \rightarrow B^2\mathcal{B}$ correspond to the following data:

- a 2-cocycle $\mu \in Z^2(G, \text{Inv}(\mathcal{B}))$, up to coboundary;
- a 3-cochain $\omega \in C^3(G, \text{Aut}(1_{\mathcal{B}}))$ such that $d\omega = (\alpha, \beta)_* \mu$, where $(\alpha, \beta)_* \mu \in Z^4(G, \text{Aut}(1_{\mathcal{B}}))$ is the 4-cocycle in the image of the Pontryagin–Whitehead morphism $^\dagger (\alpha, \beta)_* : H^2(G, \text{Inv}(\mathcal{B})) \rightarrow H^4(G, \text{Aut}_{\mathcal{B}}(1_{\mathcal{B}}))$ for the k -invariant $(\alpha, \beta) \in H^4(K(\text{Inv}(\mathcal{B}), 2), \text{Aut}(1_{\mathcal{B}}))$. An explicit expression for the 4-cocycle $(\alpha, \beta)_* \mu \in Z^4(G, \text{Aut}(1_{\mathcal{B}}))$ is given by

$$\begin{aligned}
 (\alpha, \beta)_* \mu(g, h, k, \ell) = & \beta_{\mu_{k,\ell}, \mu_{g,h}} \alpha_{\mu_{ghk,\ell}, \mu_{gh,k}, \mu_{g,h}}^{-1} \alpha_{\mu_{ghk,\ell}, \mu_{g,hk}, \mu_{h,k}} \alpha_{\mu_{g,hk,\ell}, \mu_{hk,\ell}, \mu_{h,k}}^{-1} \\
 & \alpha_{\mu_{g,hk,\ell}, \mu_{h,k,\ell}, \mu_{k,\ell}} \alpha_{\mu_{g,hk,\ell}, \mu_{g,h}, \mu_{k,\ell}}^{-1} \alpha_{\mu_{gh,k,\ell}, \mu_{k,\ell}, \mu_{g,h}}
 \end{aligned} \tag{7}$$

This explicit expression can also be obtained, up to conventions, by taking the trivial G -action in [16, eq. (5.6)].

In fact, after strictifying \mathcal{B} to a strict braided monoidal category, so that $B^2\mathcal{B}$ is a Gray-category, these cohomological data may be directly read off from the components of the weak 3-functor $\pi : BG \rightarrow B^2\mathcal{B}$, using notation from Appendix A, as follows: We may assume the underlying 2-functor of π is strictly unital, that is, $\pi_g^1 = \text{id}_{1_{\mathcal{B}}}$ for all $g \in G$. By (F-I).ii, this implies $\pi_{g,h}^2 = \text{id}_{1_{\mathcal{B}}}$ for all $g, h \in G$. We write $\mu_{g,h} := \mu_{g,h}^\pi \in \text{Inv}(\mathcal{B})$. By (F-II).iii, $\mu_{\text{id}_g, \text{id}_h}^\pi = \text{id} \in \text{End}(\mu_{g,h})$. Using the isomorphism $\omega_{g,h,k}^\pi : \mu_{g,h,k} \otimes \mu_{g,h} \rightarrow \mu_{g,hk} \otimes \mu_{h,k}$, μ descends to a 2-cocycle in $Z^2(G, \text{Inv}(\mathcal{B}))$. To translate ω^π into a 3-cochain in $C^3(G, \text{Aut}_{\mathcal{B}}(1_{\mathcal{B}}))$, we let C be a skeletalization of \mathcal{B}^\times . In C , we may identify all automorphism spaces of C with $\text{Aut}(1_{\mathcal{B}})$, and hence recover the associator α in C as an element of $Z^3(\text{Inv}(C), \text{Aut}(1_{\mathcal{B}}))$, and descend the isomorphisms $\omega_{g,h,k}^\pi : \mu_{g,h,k} \otimes \mu_{g,h} \rightarrow \mu_{g,hk} \otimes \mu_{h,k}$ to a 3-cochain ω in $C^3(G, \text{Aut}_{\mathcal{B}}(1_{\mathcal{B}}))$. Unpacking ‡ (F-1) leads to $d\omega = (\alpha, \beta)_* \mu$.

† Under the isomorphism $H^4(K(\text{Inv}(\mathcal{B}), 2), \text{Aut}(1_{\mathcal{B}})) \cong H^3_{ab}(\text{Inv}(\mathcal{B}), \text{Aut}(1_{\mathcal{B}}))$, the abelian 3-cocycle (α, β) corresponds to a map $(\alpha, \beta)_* : K(\text{Inv}(\mathcal{B}), 2) \rightarrow K(\text{Aut}(1_{\mathcal{B}}), 4)$. From this perspective, the Pontryagin–Whitehead morphism $(\alpha, \beta)_* : H^2(G, \text{Inv}(\mathcal{B})) \rightarrow H^4(G, \text{Aut}_{\mathcal{B}}(1_{\mathcal{B}}))$ is simply given by postcomposing a class $\omega : BG \rightarrow K(\text{Inv}(\mathcal{B}), 2)$ with $(\alpha, \beta)_*$.

‡ Unpacking (F-1) in C introduces six additional associator terms, one for every vertex of the hexagon commutative diagram. As these terms correspond to the two different ways to associate each of the vertex 1-cells in (F-1), the associators alternate α and α^{-1} around the diagram. The resulting 12 sided commutative diagram exactly reproduces, up to conventions, a simplification of [16, fig. 1] where the G -action is trivial. Five of these 12 terms give $d\omega$, while the other 7 terms give (7). Since the diagram commutes, we have $d\omega = (\alpha, \beta)_* \mu$ as desired.

We can now explicitly describe the G -crossed braided category resulting from our construction from these cohomological data by interpreting the diagrams (2), (3), (4), (5), (6).

- All g -graded components are \mathcal{B} .
- The monoidal structure is given by interpreting (2): $a_g \otimes b_h := \mu_{g,h} \otimes a_g \otimes b_h$, with associator given by interpreting (3):

$$\begin{aligned} \mu_{g,h,k} \otimes \mu_{g,h} \otimes a_g \otimes b_h \otimes c_k &\xrightarrow{\omega_{g,h,k}^\pi \otimes \text{id}} \mu_{g,hk} \otimes \mu_{h,k} \otimes a_g \otimes b_h \otimes c_k \\ \text{id} \otimes \beta_{a_g, \mu_{h,k}}^{-1} \otimes \text{id} &\xrightarrow{\hspace{10em}} \mu_{g,hk} \otimes a_g \otimes \mu_{h,k} \otimes b_h \otimes c_k. \end{aligned}$$

- The G -action is given by interpreting (4): $F_g(b_h) := \mu_{g,h,g^{-1}} \otimes \mu_{g,h} \otimes b_h \otimes \mu_{g,g^{-1}}^{-1}$, with tensorator ψ^g given by interpreting (5).
- The G -crossed braiding is given by interpreting (6).

One can view the resulting G -crossed extension as a twisting of the trivial extension by a 2-cycle [23, proof of Theorem 1.3]. When \mathcal{B} is fusion, this is a G -crossed *zesting* of the trivial G -crossed extension $\mathcal{B} \boxtimes \text{Vec}(G)$ of \mathcal{B} [17].

Example 1.11 (Generalized relative center construction). The article [10] shows that every (weak) G -action on a 2-category may be strictified to a strict G -action on a strict 2-category, encoded by a group homomorphism $\pi : G \rightarrow \text{Aut}^{\text{st}}(\mathcal{B})$, where $\text{Aut}^{\text{st}}(\mathcal{B})$ is the group of strict 2-equivalences of \mathcal{B} which admit strict inverses. From such a strict G -action, the authors then construct a G -crossed braided monoidal category $Z_G(\mathcal{B})$ whose g -graded component is the category of pseudonatural transformations and modifications $\text{PseudoNat}(\text{id}_{\mathcal{B}} \Rightarrow \pi(g))$. Since $\pi(e) = \text{id}_{\mathcal{B}}$, the trivial graded component is the Drinfeld center $Z(\mathcal{B})$. This construction generalizes the construction of the relative center $Z_C(D)$ of a G -extension D of a fusion category C ; by [29], $Z_C(D)$ is a G -crossed braided fusion category whose trivial graded component is $Z(C)$.

Our construction of a G -crossed braided monoidal category from a G -pointed 3-category may be understood as a generalization of [10] from G -actions on 2-categories, encoded by 3-functors $BG \rightarrow 2\text{Cat}$ from BG into the 3-category of 2-categories, to arbitrary 3-functors $BG \rightarrow \mathcal{C}$. In particular, we show in Subsection 3.2 that we may strictify a 1-surjective weak 3-functor $BG \rightarrow \mathcal{C}$ to a Gray-functor $BG \rightarrow \mathcal{C}'$ into a Gray-category \mathcal{C}' equivalent to \mathcal{C} , and construct a G -crossed braided category from these data.

Example 1.12 (G -crossed extension theory for braided fusion categories). Let \mathcal{C} be a braided fusion category, and consider the monoidal 2-category $\text{Mod}(\mathcal{C})$ of finite semisimple module categories [19, 31]. Given a monoidal 2-functor $\pi : G \rightarrow \text{Mod}(\mathcal{C})$, our construction produces the G -crossed braided fusion category

$$\bigoplus_{g \in G} \text{Hom}(C_C \rightarrow \pi(g)_C) \cong \bigoplus_{g \in G} \pi(g)$$

which is a G -crossed braided extension of the e -graded piece $\text{End}_{\text{Mod}(\mathcal{C})}(C_C) \cong C$. This G -crossed braided category is equivalent to the G -crossed extension constructed in [23] (which moreover gives an alternate proof that faithful G -crossed extensions of braided fusion categories are in fact classified by monoidal 2-functors $G \rightarrow \text{Mod}(\mathcal{C})$).

Example 1.13 (Permutation crossed extensions). Let C be a symmetric monoidal 3-category, and let A be an object of C . Then there exists a monoidal 2-functor $\pi : S_n \rightarrow \text{End}(A^{\boxtimes n})$, where \boxtimes denotes the symmetric monoidal product in C . Our construction produces a S_n -crossed braided category whose trivially graded piece is $\text{End}(\text{id}_{A^{\boxtimes n}})$. For example, if \mathcal{A} is an object in the 3-category of fusion categories [20, 37, 40], there is an equivalence

$$\text{End}(\text{id}_{\mathcal{A}^{\boxtimes n}}) \cong Z(\mathcal{A}^{\boxtimes n}) \cong Z(\mathcal{A})^{\boxtimes n},$$

where $Z(\mathcal{A})$ is the Drinfeld center of \mathcal{A} , and the resulting S_n -crossed braided category is what is known as a *permutation crossed extension* of $Z(\mathcal{A})^{\boxtimes n}$. More generally, the article [28] shows that such permutation crossed extensions of $C^{\boxtimes n}$ exist for any modular tensor category.

Example 1.14 (Conformal nets). Consider the symmetric monoidal 3-category[†] of coordinate free conformal nets CN defined in [6–9, 18]. A 3-functor $BG \rightarrow \text{CN}$ amounts to a conformal net $\mathcal{A} \in \text{CN}$ together with a generalized action of G on the net \mathcal{A} by invertible topological defects. Applied to such a 3-functor, our construction produces a G -crossed braided category whose trivial graded component is the braided category $\text{End}_{\text{CN}}(1_{\mathcal{A}}) = \text{Rep}(\mathcal{A})$ of (super-selection) sectors [6, section 1.B] of \mathcal{A} . We expect this generalizes a construction of Müger [49], which produces a G -crossed braided category from the action of global symmetries on a *coordinatized* conformal net. However, it is difficult to compare these two G -crossed braided categories, since it is not obvious how to construct a symmetric monoidal 3-category of coordinatized conformal nets.

Example 1.15 (Topological phases). The collection of (2+1)D gapped topological phases is expected to form a 3-category [25, 26]. Given a global, onsite symmetry, there is an associated G -crossed braided category of twist defects [3]. Our construction can be understood as a direct generalization of this heuristic. Indeed, our pictures and arguments can be viewed as a more mathematically precise version of the arguments and structure given in the physical context (for example, see [3, fig. 7]).

Example 1.16 (Homotopy quantum field theory). *Homotopy quantum field theories* are topological field theories on bordisms equipped with a map to a fixed target space. If this target space is the classifying space BG of a finite group G , such field theories are also known as *G -equivariant field theories*. Following the cobordism hypothesis [1, 47], such a fully extended (framed) 3-dimensional G -equivariant topological field theory valued in a fully dualizable symmetric monoidal 3-category corresponds to a 3-functor $BG \rightarrow C$ (that is, a fully dualizable object A in C equipped with an ‘internal G -action’, given by a monoidal 2-functor $X : G \rightarrow \text{End}_C(A)$). It therefore follows from Theorem A that to any such field theory, there is an associated G -crossed braided category.

In particular, if Fus is the 3-category of fusion categories introduced in [20], we expect the G -crossed braided category constructed via Theorem A from a fully extended G -equivariant 3-dimensional field theory valued in Fus to coincide with the G -crossed braided category constructed in [52] by evaluating the field theory on (G -structured) circles. In particular, if G is trivial, this recovers the construction of the Drinfeld center of a fusion category \mathcal{A} as $\text{FusCat}(\mathcal{A}, \mathcal{A}, \mathcal{A} \Rightarrow \mathcal{A}, \mathcal{A}, \mathcal{A})$.

[†] The notion of tricategory used in [8, 18], namely, an internal bicategory in Cat , is expected, but not proven to be equivalent to the notion of algebraic tricategory [35] used in the present article.

1.4 | Outline

Section 2 contains basic definitions and a brief introduction to the graphical calculus of Gray-monoids used throughout.

Section 3 proves various strictification results for 1-surjective pointed 3-categories (Subsection 3.1) and higher morphisms between them (Subsections 3.2, 3.3, 3.4, and 3.5) and shows that 3Cat_G (Definition 3.2) is equivalent to its strict sub-2-category $3\text{Cat}_G^{\text{st}}$ (Corollary 3.5).

Section 4 defines the 2-category $G\text{CrSBrd}$ of G -crossed braided categories (Subsection 4.1) and its equivalent full sub-2-category $G\text{CrSBrd}^{\text{st}}$, constructs the strict 2-functor $3\text{Cat}_G^{\text{st}} \rightarrow G\text{CrSBrd}^{\text{st}}$ (Subsection 4.2) and proves that it is an equivalence (Subsection 4.3).

Section 5 discusses how various properties and structures on a 1-surjective G -pointed 3-category, such as linearity and rigidity, may be translated across the equivalence of Theorem A to the resulting G -crossed braided category.

Appendix A unpacks the definitions of (weak) 3-functors, transformations, modifications and perturbations between Gray-monoids in terms of the graphical calculus.

Appendices B and C contain most of the coherence proofs from Sections 3 and 4, respectively.

2 | BACKGROUND ON 3-CATEGORIES AND MONOIDAL 2-CATEGORIES

In this article, by a 3-category we mean an algebraic tricategory in the sense of [35, Definition 4.1], and by *functor*, *transformation*, *modification*, and *perturbation*, we mean the corresponding notions of trihomomorphism, tritransformation, trimodification, and perturbation of [35, Definitions 4.10, 4.16, 4.18, 4.21]. We include Appendix A which unpacks the full definitions of these notions for Gray-monoids using the graphical calculus discussed in Subsection 2.2. When we consider stricter notions of categories or functors we will always use appropriate adjectives such as ‘Gray’ or ‘strict’.

Remark 2.1. In this article, we use the term *invertible* as a property, that is, the existence of a coherent inverse. Indeed, by [34], every invertible 1-morphism (biequivalence) in a 3-category is part of a biadjoint biequivalence, and every invertible 2-morphism is part of an adjoint equivalence. Moreover, there is a contractible space of choices for these coherent inverses. Whenever we need to make such choices, we will refer back to this remark.

2.1 | Gray-categories and Gray-monoids

In this section, we give a terse definition of Gray-category and Gray-monoid, and a brief discussion on the diagrammatic calculus for Gray-monoids. We refer the reader to [33] for a more detailed treatment of Gray-categories and to [4, section 2.6] or [5] for a more detailed treatment of the graphical calculus.

Definition 2.2. The symmetric monoidal category Gray is the 1-category of strict 2-categories and strict 2-functors equipped with the Gray monoidal structure [33, section 5]. A Gray-category is a category enriched in Gray in the sense of [42]. A Gray-monoid is a monoid object in Gray . Given a Gray-monoid C , its *delooping* BC is the Gray-category with one object and endomorphisms C .

We now unpack the notion of Gray-monoid from Definition 2.2.

Notation 2.3. Given a Gray-monoid C , we refer to its objects, 1-morphisms, and 2-morphisms as 0-cells, 1-cells, and 2-cells, respectively, in order to distinguish these basic components of C from morphisms in an ambient category in which C lives.

The remarks and warning below are adapted directly from [19].

Remark 2.4. Unpacking Definition 2.2, a Gray-monoid consists of the following data:

- (D1) a strict 2-category C , where composition of 1-morphisms is denoted by \circ and composition of 2-morphisms is denoted by $*$;
- (D2) an identity 0-cell $1_C \in C$;
- (D3) strict left and right tensor product 2-functors $L_a = a \otimes -$ and $R_a = - \otimes a$ for each object $a \in C$:

$$L_a = a \otimes - : C \rightarrow C$$

$$R_a = - \otimes a : C \rightarrow C,$$

- (D4) an interchanger 2-isomorphism $\phi_{x,y}$ for each pair of 1-cells $x : a \rightarrow b$ and $y : c \rightarrow d$:

$$\phi_{x,y} : (x \otimes \text{id}_d) \circ (\text{id}_a \otimes y) \Rightarrow (\text{id}_b \otimes y) \circ (x \otimes \text{id}_c)$$

subject to the following conditions:

- (C1) left and right tensor product agree: for all objects $a, b \in C$, $L_a b = R_b a = a \otimes b$;
- (C2) tensor product is strictly unital and associative:

$$L_{1_C} = \text{id}_C = R_{1_C}$$

$$L_a L_b = L_{a \otimes b}$$

$$R_b R_a = R_{a \otimes b}$$

$$L_a R_b = R_b L_a;$$

- (C3) the interchanger ϕ respects identities, that is, for a 0-cell $A \in C$ and a 1-cell $f : C \rightarrow D$,

$$\phi_{f, \text{id}_A} = \text{id}_{f \otimes A}$$

$$\phi_{\text{id}_A, f} = \text{id}_{A \otimes f}$$

- (C4) the interchanger ϕ respects composition, that is, for $x : a \rightarrow a'$, $x' : a' \rightarrow a''$, $y : b \rightarrow b'$ and $y' : b' \rightarrow b''$,

$$\phi_{x' \circ x, y} = (\phi_{x', y} \circ (x \otimes \text{id}_b)) * ((x' \otimes \text{id}_{b'}) \circ \phi_{x, y})$$

$$\phi_{x, y' \circ y} = ((\text{id}_{a'} \otimes y') \circ \phi_{x, y}) * (\phi_{x, y'} \circ (\text{id}_a \otimes y))$$

(C5) the interchanger ϕ is natural, that is, for 1-cells $x, x' : a \rightarrow a', y, y' : b \rightarrow b'$ and 2-cells $\alpha : x \Rightarrow x', \beta : y \Rightarrow y'$,

$$\phi_{x',y} * ((\alpha \otimes \text{id}_{b'}) \circ (\text{id}_a \otimes y)) = ((\text{id}_{a'} \otimes y) \circ (\alpha \otimes \text{id}_b)) * \phi_{x,y}$$

$$\phi_{x,y'} * ((x \otimes \text{id}_{b'}) \circ (\text{id}_a \otimes \beta)) = ((\text{id}_{a'} \otimes \beta) \circ (x \otimes \text{id}_b)) * \phi_{x,y}$$

(C6) the interchanger ϕ respects tensor product, that is, for $x : a \rightarrow a', y : b \rightarrow b'$ and $z : c \rightarrow c'$,

$$\phi_{\text{id}_a \otimes y, z} = \text{id}_a \otimes \phi_{y, z}$$

$$\phi_{x \otimes \text{id}_b, z} = \phi_{x, \text{id}_b} \otimes z$$

$$\phi_{x, y \otimes \text{id}_c} = \phi_{x, y} \otimes \text{id}_c$$

A Gray-monoid is called *linear* if the underlying 2-category is linear and for all objects a the functors $a \otimes -$ and $- \otimes a$ are linear.

Warning 2.5 (Horizontal composition of 1-morphisms). We warn the reader that the tensor product in a Gray-monoid does *not* provide a unique definition of the tensor product of two 1-cells. Given $x : a \rightarrow b$ and $y : c \rightarrow d$, we define

$$x \otimes y := (x \otimes \text{id}_d) \circ (\text{id}_a \otimes y); \tag{8}$$

this convention is known as *nudging* [30, section 4.5]. We use a similar nudging convention for the tensor product of 2-cells. With this convention, the data of a Gray-monoid C as described in Definition 2.4 give rise to an (*op*cubical cf [35, section 8]) algebraic tricategory BC [35, Theorem 8.12].

Remark 2.6 (Strictification for monoidal 2-categories). By the strictification for tricategories from [30] or [35, Corollary 9.16], every (linear) weakly monoidal weak 2-category admits a monoidal 2-equivalence to a (linear) Gray-monoid of the form in Definition 2.4.

2.2 | Graphical calculus for Gray-monoids

Gray-categories admit a graphical calculus of surfaces, lines, and vertices in 3-dimensional space. We refer the reader to [4, section 2.6] for a rigorous discussion. Here, we will only ever work in a 2-dimensional projection of this graphical calculus for Gray-monoids. Our exposition below follows [5].

The 0-cells of our strict 2-category C (D1) are denoted by strands in the plane

$$a \mid$$

and the identity 0-cell 1_c (D2) is denoted by the empty strand. The 1-cells are denoted by coupons between labeled strands

$$x : a \rightarrow b \quad \begin{array}{c} b \\ | \\ \textcircled{x} \\ | \\ a \end{array}$$

The composition of 1-cells is denoted by vertical stacking of such diagrams.

The strict tensor product \otimes is denoted by horizontal juxtaposition. For example, the tensor product functors L_a and R_a (D3) are denoted by placing a strand labeled by a to the left or right, respectively.

$$L_a(x : b \rightarrow c) := \text{id}_a \otimes x = \begin{array}{c} c \\ | \\ \textcircled{x} \\ | \\ b \end{array} \quad R_a(x : b \rightarrow c) := x \otimes \text{id}_a = \begin{array}{c} c \\ | \\ \textcircled{x} \\ | \\ b \end{array} \begin{array}{c} | \\ | \\ | \\ | \\ a \end{array}$$

Given $x : a \rightarrow b$ and $y : c \rightarrow d$, we define their tensor product using the nudging convention from Warning 2.5.

$$x \otimes y := (x \otimes \text{id}_d) \circ (\text{id}_a \otimes y) = \begin{array}{c} b \quad d \\ | \quad | \\ \textcircled{x} \\ | \quad | \\ a \quad c \\ | \quad | \\ \textcircled{y} \\ | \quad | \\ a \quad c \end{array}$$

Observe that no two coupons ever share the same vertical height.

The 2-cells are inherently 3-dimensional, and can be thought of as ‘movies’ between our 2-dimensional string diagrams. Rather than drawing 2-cells, we denote them by arrows \Rightarrow between diagrams corresponding to their source and target 1-cells. For example, the interchanger $\phi_{x,y}$ from (D4) is simply denoted by

$$\begin{array}{c} b \quad d \\ | \quad | \\ \textcircled{x} \\ | \quad | \\ a \quad c \\ | \quad | \\ \textcircled{y} \\ | \quad | \\ a \quad c \end{array} \xRightarrow{\phi_{x,y}} \begin{array}{c} b \quad d \\ | \quad | \\ \textcircled{y} \\ | \quad | \\ a \quad c \\ | \quad | \\ \textcircled{x} \\ | \quad | \\ a \quad c \end{array}$$

Notation 2.7. When working with Gray-monoids, one often needs to whisker 2-cells between 1-cells, and the notation can quickly become cumbersome. Instead, we use the convention of a dashed box when we apply a 2-cell locally to a 1-cell, and we simply label the whiskered 2-cell by the name of the locally applied 2-cell. Later on, we will draw commutative diagrams whose vertices are 1-cells. When we want to apply two 2-cells locally in different places to the same 1-cell, we will use two dashed boxes with different colors, usually red and blue. When one of these two 2-cells is applied to the entire diagram, we do not use a dashed box, and we only use one dashed box of another color, usually red. As an explicit example, the second equation in (C4) in

string diagrams is given by:

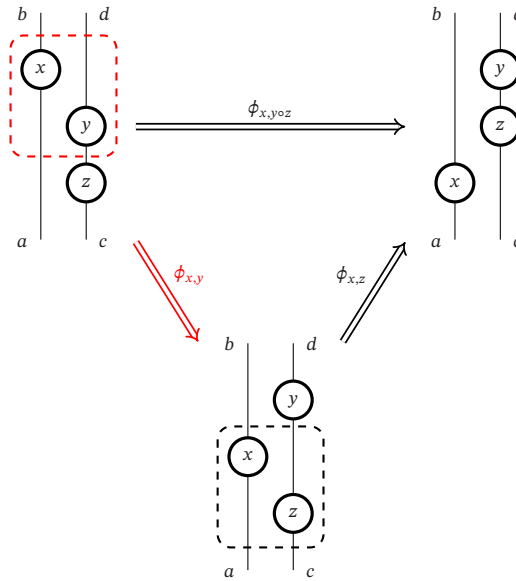

For the convenience of the reader, we have included Appendix A which unpacks the notions of 3-functor, transformation, modification, and perturbation for Gray-monoids using this graphical calculus.

3 | STRICTIFYING G -POINTED 3-CATEGORIES

Let G be a group. We recall from Subsection 1.1 that BG denoted the *delooping* of G , that is, G considered as a 1-category with one object. As discussed at the beginning of Section 2, the terms *n-category* and *n-functor* for $n \leq 3$ will always mean weak n -categories and weak n -functors. Observe that since a k -category may be viewed as an n -category for $n \geq k$ with only identity higher morphisms, we may talk about an n -functor from a k -category to an n -category. Recall from Remark 2.1 that we use the adjective *invertible* for (bi)adjoint (bi)equivalences.

Definition 3.1. A 3-functor $A : C \rightarrow D$ is 1-surjective if it is essentially surjective on objects and if for every pair of objects c_1, c_2 of C , the 2-functors $A_{c_1, c_2} : C(c_1 \rightarrow c_2) \rightarrow D(A(c_1) \rightarrow A(c_2))$ are essentially surjective on objects.

Definition 3.2. Let G be a group. We define the 4-category ${}^\dagger 3\text{Cat}_G$ of G -pointed 3-categories to be the full sub-4-category of the under-category $3\text{Cat}_{BG/}$ on the 1-surjective 3-functors $BG \rightarrow C$. Explicitly, this 4-category can be described as follows:

- objects are 3-categories C equipped with a 1-surjective 3-functor $\pi^C : BG \rightarrow C$;

[†] All results in this section can be stated and proved at the level of various 2-categories of $(k - 1)$ -morphisms, k -morphisms and equivalence classes of $(k + 1)$ -morphisms of 3Cat_G ; we therefore will not show that 3Cat_G forms a 4-category — and in fact will not even choose any definition of 4-category. We only use the conceptual idea of a 4-category as an underlying organizational principle for our results.

- 1-Morphisms $(A, \alpha) : (C, \pi^C) \rightarrow (D, \pi^D)$ are pairs where $A : C \rightarrow D$ is a 3-functor and $\alpha : \pi^D \Rightarrow A \circ \pi^C$ is an invertible natural transformation;
- 2-Morphisms $(\eta, m) : (A, \alpha) \Rightarrow (B, \beta)$ are pairs where $\eta : A \Rightarrow B$ is a natural transformation and m is an invertible modification

$$\begin{array}{ccc}
 BG & \xrightarrow{\pi^C} & C \\
 & \searrow \pi^D & \downarrow B \\
 & & D
 \end{array}
 \begin{array}{c}
 \nearrow \beta \\
 \nearrow \alpha
 \end{array}
 \xrightarrow{m}
 \begin{array}{ccc}
 BG & \xrightarrow{\pi^C} & C \\
 & \searrow \pi^D & \downarrow A \\
 & & D
 \end{array}
 \begin{array}{c}
 \nearrow \alpha \\
 \nearrow \eta
 \end{array}
 \xrightarrow{\eta}
 \begin{array}{ccc}
 & & B \\
 & & \downarrow \\
 & & D
 \end{array}
 \quad (9)$$

- 3-Morphisms $(p, \rho) : (\eta, m) \Rightarrow (\zeta, n)$ are modifications $p : \eta \Rightarrow \zeta$ together with an invertible perturbation ρ :

$$\begin{array}{ccc}
 \pi^D & \xrightarrow{\alpha} & A \circ \pi^C \\
 & \searrow \beta & \downarrow \zeta \circ \pi^C \\
 & & B \circ \pi^C
 \end{array}
 \begin{array}{c}
 \nearrow n \\
 \nearrow m
 \end{array}
 \xrightarrow{\rho}
 \begin{array}{ccc}
 \pi^D & \xrightarrow{\alpha} & A \circ \pi^C \\
 & \searrow \beta & \downarrow \eta \circ \pi^C \\
 & & B \circ \pi^C
 \end{array}
 \begin{array}{c}
 \nearrow m \\
 \nearrow p \circ \pi^C
 \end{array}
 \xrightarrow{\zeta \circ \pi^C}
 \begin{array}{ccc}
 & & \zeta \circ \pi^C \\
 & & \downarrow \\
 & & B \circ \pi^C
 \end{array}
 \quad (10)$$

- 4-Morphisms $\xi : (p, \rho) \Rightarrow (q, \delta)$ are perturbations $\xi : p \Rightarrow q$ satisfying

$$\begin{array}{ccc}
 \beta & \xrightarrow{m} & (\eta \circ \pi^C) * \alpha \\
 & \searrow n & \downarrow (q \circ \pi^C) * \alpha \\
 & & (\zeta \circ \pi^C) * \alpha
 \end{array}
 \begin{array}{c}
 \nearrow \delta \\
 \nearrow \rho
 \end{array}
 =
 \begin{array}{ccc}
 \beta & \xrightarrow{m} & (\eta \circ \pi^C) * \alpha \\
 & \searrow n & \downarrow (p \circ \pi^C) * \alpha \\
 & & (\zeta \circ \pi^C) * \alpha
 \end{array}
 \begin{array}{c}
 \nearrow \rho \\
 \nearrow (\xi \circ \pi^C) * \alpha
 \end{array}
 \xrightarrow{(q \circ \pi^C) * \alpha}
 \begin{array}{ccc}
 & & (q \circ \pi^C) * \alpha \\
 & & \downarrow \\
 & & (\zeta \circ \pi^C) * \alpha
 \end{array}
 \quad (11)$$

Remark 3.3. As stated, Definition 3.2 and Theorem 3.4 assume the existence of a (weak) 4-category 3Cat of algebraic tricategories, trifunctors, tritransformations, modifications, and perturbations which has the appropriate homotopy bicategories between parallel k -morphisms. Assuming the existence of such a 4-category 3Cat , we may define 3Cat_G as a certain full sub-4-category of the under-category as in Definition 3.2. In Theorem 3.4 we show, working a bicategory at a time, that this 4-category 3Cat_G is equivalent to a sub-4-category 3Cat_G^{pt} with only identity 3- and 4-morphisms, and is hence equivalent to a bicategory. After having established Theorem 3.4, we will from then on only work with this bicategory 3Cat_G^{pt} .

Unfortunately, to the best of our knowledge, such a 4-category 3Cat has not yet been constructed in any of the established models of weak 4-category. However, none of the results in this article truly depend on the specifics of 4-categories, and 4-categories only appear as a convenient conceptual organizing tool.

The reader uncomfortable with this sort of model-independent argument may unpack the statement of our main Theorem A to assert the following.

- (1) For a pair of parallel ‘1-morphisms’ as in Definition 3.2, the bicategory of 2-morphisms, 3-morphisms and 4-morphisms between them is equivalent to a set.

(2) The bicategory of objects, 1-morphisms and 2-morphisms up to invertible 3-morphisms of Definition 3.2 is equivalent to the 2-category of G -crossed braided categories.

Theorem 3.4. *The 4-category 3Cat_G is equivalent to the 4-subcategory 3Cat_G^{pt} where*

- objects (BC, π^C) are those objects of 3Cat_G for which the 3-category is a Gray-category with one object, and hence given by BC for some Gray-monoid C , and for which $\pi^C : BG \rightarrow BC$ is a strictly 1-bijective Gray-functor. Equivalently, an object is a Gray-monoid C whose set of 0-cells is $\{g_C := \pi^C(g)\}_{g \in G}$ and composition of 0-cells given by group multiplication;
- 1-morphisms $(A, \alpha) : (BC, \pi^C) \rightarrow (BD, \pi^D)$ satisfy:
 - $A(g_C) = g_D$ for all $g \in G$,
 - the adjoint equivalence $\mu : \otimes_D \circ (A \times A) \Rightarrow A \circ \otimes_C$ satisfies $\mu_{g_C, h_C} = \text{id}_{gh_D} : g_D \otimes h_D \Rightarrow gh_D$,
 - the adjoint equivalence $t^A = (t_*^A, t_1^A) : I_D \Rightarrow A \circ I_C$ satisfies $t_*^A = \text{id}_{e_D}$, and $t_1^A = A_e^1$,
 - the associators and unitors ω^A, ℓ^A, r^A are identities,
 - $\alpha_* = e_D$ and $\alpha_g = \text{id}_{g_D}$, and $\alpha_{\text{id}_g} = A_g^1$,
 - $\alpha^1 = \text{id}_{\text{id}_{e_D}}$ and $\alpha_{g, h}^2 = \text{id}_{\text{id}_{gh_D}}$ for all $g, h \in G$;
- 2-morphisms $(\eta, m) : (A, \alpha) \Rightarrow (B, \beta)$ satisfy $\eta_{*c} = e_D$, $\eta_{g_C} = \text{id}_{g_D}$, $\eta^1 = \text{id}_{\text{id}_{e_D}}$ and $\eta_{g_C, h_C}^2 = \text{id}_{\text{id}_{gh_D}}$ and $m_* = e_D$, $m_g = \text{id}_{\text{id}_{g_D}}$. That is, m is the identity modification;
- 3-morphisms $(p, \rho) : (\eta, m) \Rightarrow (\zeta, n)$ satisfy $p_{*c} = \text{id}_{e_D}$, $p_{g_C} = \text{id}_{\text{id}_{g_D}}$, and $\rho_* = \text{id}_{\text{id}_{e_D}}$. That is, there are only identity 3-morphisms;
- 4-morphisms $\xi : (p, \rho) \Rrightarrow (q, \delta)$ satisfy $\xi_{*c} = \text{id}_{\text{id}_{e_D}}$. That is, the only 4-endomorphism of an identity 3-morphism is the identity.

Proof. In Subsections 3.1, 3.2, 3.3, 3.4, and 3.5, we show that every object, 1-morphism, 2-morphism, 3-morphism, and 4-morphism, respectively, in 3Cat_G is equivalent to one of the desired form in 3Cat_G^{pt} . All proofs in these further subsections amount to checking the appropriate coherences for 3-functors, 3-natural transformations, 3-modifications, and 3-perturbations outlined in Appendix A and are deferred to Appendix B. We signify where the reader may find the deferred proof of a statement by including a small box with a link to the appropriate appendix after the statement. □

Since the only 3- and 4-morphisms of 3Cat_G^{pt} are identities, it is evident that 3Cat_G^{pt} — and hence by Theorem 3.4 also 3Cat_G — is 2-truncated and actually defines a 2-category. In the following corollary, we give a streamlined description of this 2-category without the redundant data.

Corollary 3.5. *The 4-category 3Cat_G^{pt} is isomorphic to the strict 2-category $3\text{Cat}_G^{\text{st}}$, defined as follows.*

- An object is a Gray-monoid C whose set of 0-cells is G (below, we will denote the elements of G seen as 0-cells in C by g_C) and composition of 0-cells is given by group multiplication.
- A 1-morphism $A : C \rightarrow D$ is a 3-functor $A : BC \rightarrow BD$ such that
 - $A(g_C) = g_D$ for all $g \in G$,
 - the adjoint equivalence $\mu : \otimes_D \circ (A \times A) \Rightarrow A \circ \otimes_C$ satisfies $\mu_{g, h} = \text{id}_{gh} : g_D \otimes h_D \Rightarrow gh_D$,
 - the adjoint equivalence $t^A = (t_*^A, t_1^A) : I_D \Rightarrow A \circ I_C$ satisfies $t_*^A = \text{id}_{e_D}$, and $t_1^A = A_e^1$,
 - the associators and unitors ω^A, ℓ^A, r^A are identities.

- A 2-morphism $\eta : A \Rightarrow B$ is a natural transformation such that $\eta_* = e_D$, $\eta_g = \text{id}_{g_D}$, $\eta^1 = \text{id}_{\text{id}_{e_D}}$ and $\eta_{g,h}^2 = \text{id}_{\text{id}_{gh_D}}$ for all $g, h \in G$.

Composition of 1- and 2-morphisms is the usual composition of 3-functors and natural transformations [35].

Proof. The natural transformation α , the modifications m and p and the perturbations ρ and ξ in the statement of Theorem 3.4 are completely determined by the imposed conditions on their coefficients. Moreover, the so defined coefficients always assemble into natural transformations, modifications, and perturbations, respectively, between the respective morphisms described in Corollary 3.5.

We now show that $3\text{Cat}_G^{\text{st}}$ is indeed a strict 2-category. Suppose we have two composable 1-morphisms $(A, A^1, A^2, \mu^A, \iota^A) \in 3\text{Cat}_G^{\text{st}}(D \rightarrow \mathcal{E})$ and $(B, B^1, B^2, \mu^B, \iota^B) \in 3\text{Cat}_G^{\text{st}}(C \rightarrow D)$. Then the formulae for the components for the composite $(A \circ B, (A \circ B)^2, (A \circ B)^1, \mu^{A \circ B}, \iota^{A \circ B})$ are given by

$$\begin{aligned} (A \circ B)_g^1 &= A(B_g^1) * A_g^1 && \forall g \in G \\ (A \circ B)_{x,y}^2 &= A(B_{x,y}^2) * A_{B(x),B(y)}^2 && \forall x \in C(h_C \rightarrow k_C), \forall y \in C(g_C \rightarrow h_C) \\ \mu_{x,y}^{A \circ B} &= A(\mu_{x,y}^B) * \mu_{B(x),B(y)}^A && \forall x \in C(g_C \rightarrow k_C), \forall y \in C(h_C \rightarrow \ell_C) \\ \iota_1^{A \circ B} &= A(\iota_1^B) * \iota_1^A, \end{aligned}$$

which are easily seen to be strictly associative and strictly unital. It is also straightforward to see that composition of 2-morphisms is strictly associative and strictly unital as well. \square

3.1 | Strictifying objects

In the following section, we prove the ‘object part’ of Theorem 3.4 and show that every object $\pi = \pi^C : BG \rightarrow C$ of the 4-category 3Cat_G is equivalent to a strictly 1-bijective Gray-functor $\pi' : BG \rightarrow BC'$, where C' is a Gray-monoid whose set of 0-cells is G with composition the group multiplication. The following lemma is a direct consequence of Gurski’s strictification of 3-categories [35, Corollary 9.15].

Lemma 3.6. *Any 1-surjective 3-functor $\pi : BG \rightarrow C$ is equivalent, in 3Cat_G , to a 1-surjective 3-functor $\pi' : BG \rightarrow BC'$ where C' is a Gray-monoid.*

Proof. By [35, Corollary 9.15], there is a Gray-category C'_0 and a 3-equivalence $C \rightarrow C'_0$. By 1-surjectivity of π , it follows that the composite $BG \rightarrow C \rightarrow C'_0$ factors through the full endomorphism Gray-monoid C' of C'_0 on the single object in the image of the composite, resulting in a 3-functor $\pi' : BG \rightarrow BC'$ which is equivalent to $\pi : BG \rightarrow C$ in 3Cat_G . \square

To further strictify $\pi : BG \rightarrow BC$, we use the following direct consequence of a theorem of Buhné [12]. Recall that a 3-functor $F : \mathcal{A} \rightarrow \mathcal{B}$ between Gray-categories \mathcal{A} and \mathcal{B} is *locally strict* if the 2-functors $F_{a,b} : \mathcal{A}(a \rightarrow b) \rightarrow \mathcal{B}(F(a) \rightarrow F(b))$ are strict.

Proposition 3.7. *Given Gray-monoids \mathcal{G}, \mathcal{C} and a locally strict 3-functor $\pi : \mathcal{B}\mathcal{G} \rightarrow \mathcal{B}\mathcal{C}$, there exists a Gray-monoid \mathcal{C}' , an equivalence $A : \mathcal{B}\mathcal{C} \rightarrow \mathcal{B}\mathcal{C}'$, a Gray-functor $\pi' : \mathcal{B}\mathcal{G} \rightarrow \mathcal{B}\mathcal{C}'$ and a natural isomorphism $\pi' \Rightarrow A \circ \pi$.*

Proof. By [12, Theorem 8], every locally strict 3-functor from a (small) Gray-category into a cocomplete Gray-category is equivalent to a Gray-functor. Here, *cocomplete* is used in the sense of enriched category theory [42, section 3.2].

Given two Gray-categories \mathcal{A}, \mathcal{B} , we denote by $[\mathcal{A}, \mathcal{B}]$ the Gray-category of Gray-functors $\mathcal{A} \rightarrow \mathcal{B}$. Consider the Gray-enriched Yoneda embedding $y : \mathcal{B}\mathcal{C} \rightarrow [(\mathcal{B}\mathcal{C})^{\text{op}}, \text{Gray}]$, where the target is cocomplete as Gray is cocomplete [42, section 3.3]. The composite

$$\mathcal{B}\mathcal{G} \xrightarrow{\pi} \mathcal{B}\mathcal{C} \xrightarrow{y} [(\mathcal{B}\mathcal{C})^{\text{op}}, \text{Gray}]$$

is a composite of a locally strict 3-functor with a Gray-functor and hence itself locally strict. Therefore, there is a Gray-functor $\pi' : \mathcal{B}\mathcal{G} \rightarrow [(\mathcal{B}\mathcal{C})^{\text{op}}, \text{Gray}]$ which is equivalent to the composite.

Now we define $\mathcal{B}\mathcal{C}'$ to be the full sub-Gray-category of $[(\mathcal{B}\mathcal{C})^{\text{op}}, \text{Gray}]$ on the object $\pi'(*)$ and define $\pi' : \mathcal{B}\mathcal{G} \rightarrow \mathcal{B}\mathcal{C}'$ as the codomain-restriction of π' to $\mathcal{B}\mathcal{C}'$. Finally, observe that both the Gray-Yoneda embedding $y : \mathcal{B}\mathcal{C} \rightarrow [(\mathcal{B}\mathcal{C})^{\text{op}}, \text{Gray}]$ and the inclusion $\mathcal{B}\mathcal{C}' \rightarrow [(\mathcal{B}\mathcal{C})^{\text{op}}, \text{Gray}]$ are fully faithful[†] Gray-functors which map the single objects of $\mathcal{B}\mathcal{C}$ and $\mathcal{B}\mathcal{C}'$ to equivalent objects. Hence, there is an equivalence $A : \mathcal{B}\mathcal{C} \rightarrow \mathcal{B}\mathcal{C}'$ and a natural isomorphism $\alpha : \pi' \Rightarrow A \circ \pi$. \square

Remark 3.8. In general, we cannot get rid of the local strictness assumption on π by the example given in [13, Example 2.2].

Theorem 3.9 (Strictifying objects). *Every object $(\mathcal{C}, \pi) \in 3\text{Cat}_{\mathcal{G}}$ is equivalent to an object $(\mathcal{B}\mathcal{C}', \pi')$ of the subcategory $3\text{Cat}_{\mathcal{G}}^{\text{Pl}}$ where $\pi' : \mathcal{B}\mathcal{G} \rightarrow \mathcal{B}\mathcal{C}'$ is a strictly 1-bijective Gray-functor into a Gray-monoid \mathcal{C}' whose set of 0-cells is G with composition the group multiplication.*

Proof. Since $\mathcal{B}\mathcal{G}$ is a 1-category, it follows from [13, Corollary 2.6] that every 3-functor $\mathcal{B}\mathcal{G} \rightarrow \mathcal{C}$ is equivalent to a locally strict 3-functor. Applying Proposition 3.7, we obtain a Gray-monoid \mathcal{D} and a Gray-functor $\pi^{\mathcal{D}} : \mathcal{B}\mathcal{G} \rightarrow \mathcal{B}\mathcal{D}$ such that $(\mathcal{B}\mathcal{D}, \pi^{\mathcal{D}})$ is equivalent to (\mathcal{C}, π) in $3\text{Cat}_{\mathcal{G}}$.

Let \mathcal{D}' be the full 2-subcategory of \mathcal{D} whose objects are exactly those in the image of $\pi^{\mathcal{D}}$. Since $\pi^{\mathcal{D}}$ is a Gray-functor, \mathcal{D}' is a Gray-submonoid of \mathcal{D} , which comes equipped with the corestricted Gray-functor $\pi^{\mathcal{D}'} : \mathcal{B}\mathcal{G} \rightarrow \mathcal{B}\mathcal{D}'$ which is strictly 1-surjective, that is, onto $\text{Ob}(\mathcal{D}')$. Since $\pi^{\mathcal{D}}$ is 1-surjective, $(\mathcal{B}\mathcal{D}, \pi^{\mathcal{D}})$ is equivalent in $3\text{Cat}_{\mathcal{G}}$ to $(\mathcal{B}\mathcal{D}', \pi^{\mathcal{D}'})$.

Since $\pi^{\mathcal{D}'} : \mathcal{B}\mathcal{G} \rightarrow \mathcal{B}\mathcal{D}'$ is a strictly 1-surjective Gray-functor, there is in particular a surjective homomorphism $\phi : G \rightarrow \text{Ob}(\mathcal{D}')$. We define a Gray-monoid \mathcal{C}' as follows. The 0-cells of \mathcal{C}' are the elements of G , and hom categories are given by $\text{Hom}_{\mathcal{C}'}(g \rightarrow h) := \text{Hom}_{\mathcal{D}'}(\phi(g) \rightarrow \phi(h))$. Since ϕ is a homomorphism, \mathcal{C}' inherits a Gray-monoid structure from \mathcal{D}' together with an obvious strictly 1-bijective Gray-homomorphism $\pi' : \mathcal{B}\mathcal{G} \rightarrow \mathcal{B}\mathcal{C}'$. Since ϕ is surjective, $(\mathcal{B}\mathcal{C}', \pi')$ is equivalent to $(\mathcal{B}\mathcal{D}', \pi^{\mathcal{D}'})$ in $3\text{Cat}_{\mathcal{G}}$. \square

[†] Here, by a *fully faithful Gray-functor* we mean a Gray-functor $F : \mathcal{A} \rightarrow \mathcal{B}$ whose induced 2-functors $F_{a,b} : \mathcal{A}(a \rightarrow b) \rightarrow \mathcal{B}(F(a) \rightarrow F(b))$ are isomorphisms in Gray.

3.2 | Strictifying 1-morphisms

Given objects (BC, π^C) and (BD, π^D) in 3Cat_G^{Dt} composed of Gray-monoids C and D and a strictly 1-bijective Gray-functor $(A, \alpha) \in 3\text{Cat}_G((BC, \pi^C) \rightarrow (BD, \pi^D))$, we construct a 1-morphism $(B, \beta) \in 3\text{Cat}_G^{Dt}$ and an equivalence $(B, \beta) \Rightarrow (A, \alpha)$. As C, D are Gray-monoids, we make heavy use of the graphical calculus discussed in Subsection 2.2.

Recall that the 3-functor A consists of the data from Definition A.1. The invertible natural transformation $\alpha : \pi^D \Rightarrow A \circ \pi^C$ is composed of the data from Definition A.2. We depict α_* by an oriented red strand:



By the third unitality bullet point in (T-II), we have that $\alpha_{\text{id}_g} = A^1_g$ since π^C is strict. By Remark 2.1, there is a contractible choice of ways to extend the invertible 0-cell α_* to a biadjoint biequivalence (BB); we do so arbitrarily.

We now define $B : BC \rightarrow BD$ as follows. First, $B(g_C) := g_D$ for all $g \in G$. Given $x \in C(g_C \rightarrow h_C)$, we define

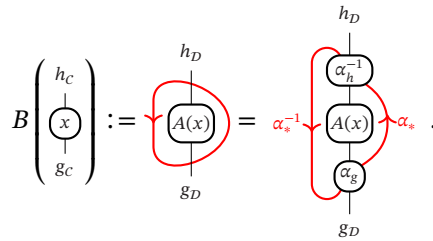

Given $x, y \in C(g_C \rightarrow h_C)$ and $f \in C(x \Rightarrow y)$, we define $B(f)$ to be the following 2-cell in D :

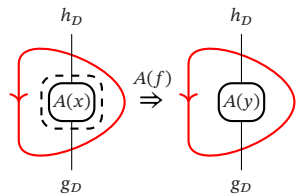

For $g \in G$, we define $B^1_g \in D(\text{id}_{g_D} \Rightarrow B(\text{id}_{g_C}))$ to be the composite

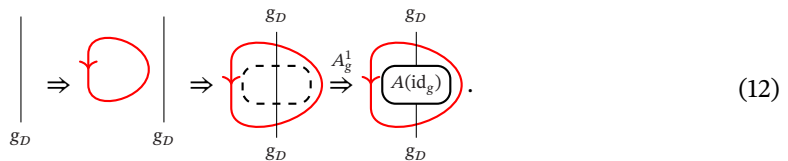

For $x \in C(g_C \rightarrow h_C)$ and $y \in C(h_C \rightarrow k_C)$, we define $B^2_{x,y} \in D(B(y) \circ B(x) \Rightarrow B(y \circ x))$ to be the composite

$$\begin{array}{c}
 k_D \\
 \downarrow \\
 \text{A}(y) \\
 \downarrow \\
 \text{A}(x) \\
 \downarrow \\
 g_D
 \end{array}
 \xRightarrow{h_D}
 \begin{array}{c}
 k_D \\
 \downarrow \\
 \text{A}(y) \\
 \downarrow \\
 \text{A}(x) \\
 \downarrow \\
 g_D
 \end{array}
 \xRightarrow{A_{x,y}^2}
 \begin{array}{c}
 k_D \\
 \downarrow \\
 \text{A}(y \circ x) \\
 \downarrow \\
 g_D
 \end{array}
 \quad (13)$$

Lemma 3.10. *The data $(B, B^1, B^2) : C \rightarrow D$ define a 2-functor.*

§B.1

We now endow B with the structure of a weak 3-functor $BC \rightarrow BD$.

Construction 3.11. We define an adjoint equivalence $\mu^B : \otimes_D \circ (B \times B) \Rightarrow B \circ \otimes_C$ as follows. First we define $\mu_{g,h}^B \in D(g_D \otimes h_D \rightarrow gh_D)$ to be the identity. Next, for $x \in C(g_C \rightarrow h_C)$ and $y \in C(k_C \rightarrow \ell_C)$, we define the natural isomorphism $\mu_{x,y}^B \in D(\mu_{g,\ell}^B \circ (B(x) \otimes B(y)) \Rightarrow B(x \otimes y) \circ \mu_{g,k}^B)$ to be the composite

We define an adjoint equivalence $t^B = (t_*^B, t_1^B) : I_D \Rightarrow B \circ I_C$ by $t_*^B = \text{id}_{e_D}$, and $t_1^B := B_e^1 \in D(\text{id}_{e_D} \Rightarrow B(\text{id}_{e_C}))$ from (12). Finally, we define the associator ω^B and unitors ℓ^B, r^B to be identities.

Lemma 3.12. *The data $(\mu^B, t^B, \omega^B, \ell^B, r^B)$ endow $B : BC \rightarrow BD$ with the structure of a weak 3-functor.*

§B.1

Lemma 3.13. *The data $\beta = (\beta_* := e_D, \beta_g := \text{id}_{g_D}, \beta_{\text{id}_g} := B_g^1, \beta^1 := \text{id}_{\text{id}_{e_D}}, \beta_{g,h}^2 := \text{id}_{\text{id}_{g h_D}})$: $\pi^D \Rightarrow B \circ \pi^C$ define a natural isomorphism.* §B.1

We now define for $x \in C(g_C \rightarrow h_C)$ the 2-cell γ_x given by

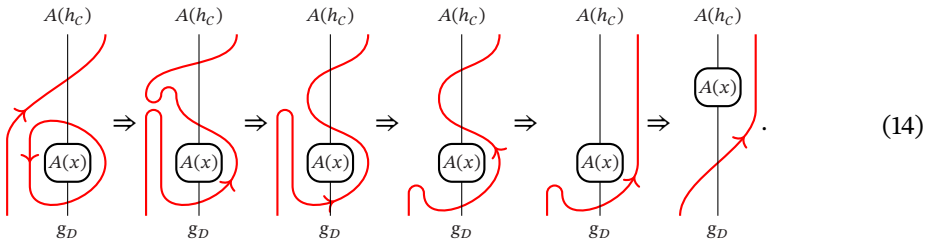

Theorem 3.14. *The 1-morphisms $(A, \alpha), (B, \beta) \in 3\text{Cat}_G((BC, \pi^C) \rightarrow (BD, \pi^D))$ are equivalent via the 2-morphism $(\gamma, \text{id}) : (B, \beta) \Rightarrow (A, \alpha)$ where $\gamma = (\gamma_* := \alpha_*, \gamma_g := \alpha_g, \gamma_x, \gamma^1 := \alpha^1, \gamma_{g,h}^2 := \alpha_{g,h}^2)$: $B \Rightarrow A$ is the natural isomorphism where γ_x is given in (14) above.* §B.1

Remark 3.15. Working a bit harder, we can actually make (B, β) strictly unital, that is, $B(\text{id}_{g_C}) = \text{id}_{g_D}$ and $B_g^1 = \text{id}_{g_D}$ for all $g \in G$. This has the following advantages: ι becomes trivial, $\mu_{\text{id}_{e_C}, x}^B = \text{id}_{B(x)}$ for all $x \in C(g_C \rightarrow h_C)$ by (F-V), $\pi^D = B \circ \pi^C$ on the nose, and $\beta : \pi^D \Rightarrow B \circ \pi^C$ is the identity transformation. Unfortunately, this would complicate our definition of the coherence data for B considerably, and it would further obfuscate the reasons why certain commuting diagrams commute in the sequel. Moreover, it has not yet been shown in the literature that every G -crossed braided functor is equivalent to a strictly unital one, although this would follow as a corollary of our main theorem. We are thus content to work with our (B, β) with β completely determined by B .

3.3 | Strictifying 2-morphisms

Suppose $(BC, \pi^C), (BD, \pi^D) \in 3\text{Cat}_G^{pt}$ and $(A, \alpha), (B, \beta) : (BC, \pi^C) \rightarrow (BD, \pi^D)$ are two 1-morphisms in 3Cat_G^{pt} . Since $(A, \alpha), (B, \beta)$ are 1-morphisms in 3Cat_G^{pt} , $A(g_C) = g_D = B(g_C)$ for all $g \in G$, and $\alpha_* = e_D = \beta_*$ and $\alpha_g = \text{id}_{g_D} = \beta_g$. Suppose $(\eta, m) \in 3\text{Cat}_G((A, \alpha) \Rightarrow (B, \beta))$. We prove that (η, m) is equivalent to a 2-morphism $(\zeta, \text{id}) \in 3\text{Cat}_G^{pt}((A, \alpha) \Rightarrow (B, \beta))$.

As in Definition A.2, we denote the 0-cell η_* by an oriented green strand. The modification $m = (m_*, m_g)$ as in Definition A.3 consists of an invertible 1-cell $m_* : \beta_* \Rightarrow \eta_* \otimes \alpha_*$ together with coherent invertible 2-cells

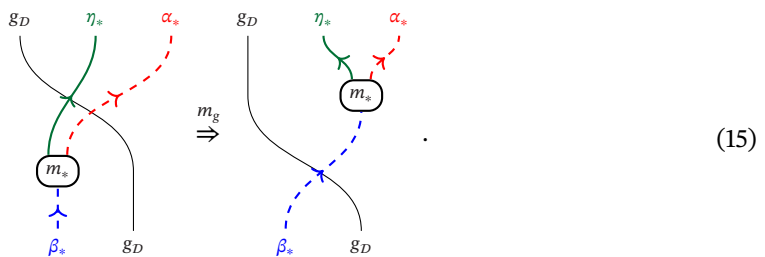

Observe that since $\beta_* = e_D = \alpha_*$ and $\beta_g = id_g = \alpha_g$, we may completely omit the dashed lines in (15). As in Remark 2.1, we extend the invertible 1-cell $m_* \in \mathcal{D}$ to an adjoint equivalence arbitrarily.

For $x \in \mathcal{C}(g_C \rightarrow h_C)$, we define an invertible 2-cell ζ_x as the following composite:

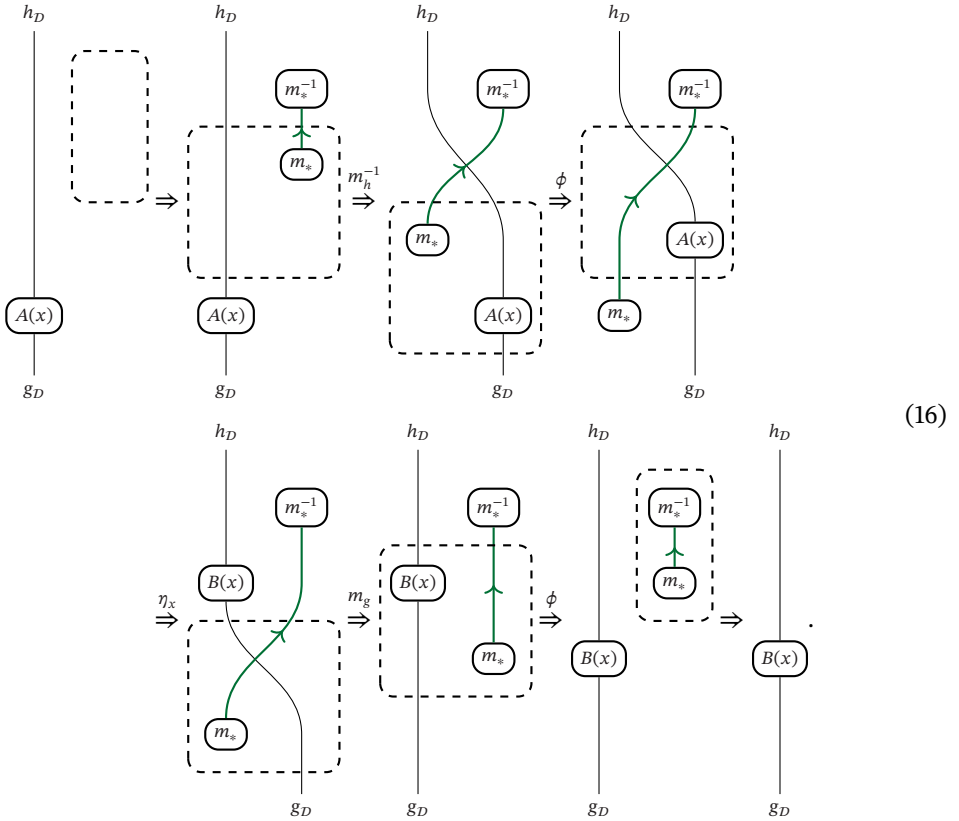

We define the unit map as in (T-III) by $\zeta^1 := id_{id_{e_D}}$ and the monoidal map as in (T-IV) by $\zeta^2_{g,h} := id_{id_{gh_D}}$.

Lemma 3.16. *The data $\zeta := (\zeta_* = e, \zeta_g = id_g, \zeta_x, \zeta^1 := id_{id_{e_D}}, \zeta^2_{g,h} := id_{id_{gh_D}})$ together with the identity modification define a 2-morphism $(\zeta, id) \in 3Cat_G^{PI}((A, \alpha) \Rightarrow (B, \beta))$. §B.2*

Observe now that by the strictness properties of α and β , $m_* : e_D \Rightarrow \eta_*$. Erasing the dotted lines from (15) for m_g , we see that the same data as $m = (m_*, m_g)$ actually define an invertible modification $\zeta \Rightarrow \eta$!

Theorem 3.17. *The 2-morphisms $(\eta, m), (\zeta, id) \in 3Cat_G((A, \alpha) \Rightarrow (B, \beta))$ are equivalent via the 3-morphism $(m, id) \in 3Cat_G((\zeta, id) \Rightarrow (\eta, id))$. §B.2*

3.4 | Strictifying 3-morphisms

Suppose now that $(\eta, m = id), (\zeta, n = id) : (A, \alpha) \Rightarrow (B, \beta)$ are two 2-morphisms in $3Cat_G^{PI}$ and $(\rho, \rho) : (\eta, id) \Rightarrow (\zeta, id)$ is a 3-morphism in $3Cat_G$.

First, since (η, id) , (ζ, id) are 2-morphisms in 3Cat_G^{pt} , we have that $\eta_* = e_D = \zeta_*$ and $\eta_g = \text{id}_{g_D} = \zeta_g$ for all $g \in G$, and the modifications are identities. This means the perturbation ρ is a 2-cell

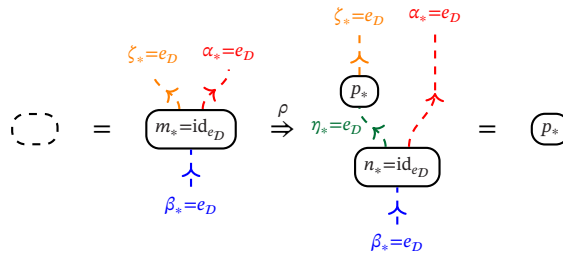

satisfying (P-1) in Definition A.4. We may thus view ρ as an invertible 2-cell $\text{id}_{\text{id}_{e_D}} \Rightarrow p_*$, under which (P-1) becomes

$$\left(\left(\begin{array}{c|c} \text{---} & \rho_* \\ \text{---} & p_* \end{array} \Bigg|_{g_D} \Rightarrow \left(\begin{array}{c} p_* \\ \text{---} \end{array} \Bigg|_{g_D} \right) \right) \Bigg|_{g_D} \Rightarrow \left(\begin{array}{c|c} \text{---} & \rho_* \\ \text{---} & p_* \end{array} \Bigg|_{g_D} \right) \quad \forall g \in G. \tag{17}$$

Lemma 3.18. Any 3-morphism in 3Cat_G between 2-morphisms in the subcategory 3Cat_G^{pt} is an endomorphism. §B.3

Theorem 3.19. Any 3-morphism in 3Cat_G between 2-morphisms in the subcategory 3Cat_G^{pt} is isomorphic to the identity 3-morphism.

Proof. First, by Lemma 3.18, every 3-morphism is a 3-endomorphism. Suppose (η, id) is a 2-morphism in 3Cat_G^{pt} and (p, ρ) is a 3-endomorphism of (η, id) . As above, we may view ρ_* as an invertible 2-morphism $\text{id}_{e_D} \Rightarrow p_*$ that satisfies (17). This is exactly saying that ρ_* is a perturbation $\text{id}_{(\eta, \text{id})} \equiv (p, \rho)$. □

3.5 | Strictifying 4-morphisms

Theorem 3.20. The only 4-endomorphism in 3Cat_G of an identity 3-morphism in the subcategory 3Cat_G^{pt} is the identity.

Proof. Suppose ξ is a 4-endomorphism of an identity 3-morphism $(p = \text{id}, \rho = \text{id})$ in 3Cat_G^{pt} . Then ξ satisfies the criterion (11), which in diagrams is

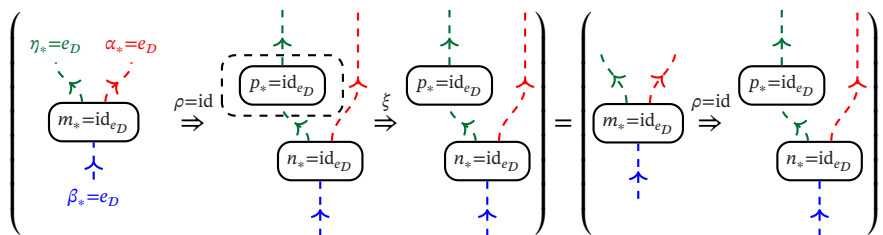

We conclude that $\xi = \text{id}$. □

4 | G -CROSSED BRAIDED CATEGORIES

In Subsection 4.1, we define the strict 2-category $GCrsBrd$ of G -crossed braided categories. By [27], $GCrsBrd$ is equivalent to the full 2-subcategory $GCrsBrd^{st}$ of strict G -crossed braided categories. In this section, we prove our second main theorem.

Theorem 4.1. *The 2-category $3Cat_G^{st}$ is equivalent to $GCrsBrd^{st}$.*

Proof. In Subsection 4.2, we construct a strict 2-functor $3Cat_G^{st} \rightarrow GCrsBrd^{st}$. In Subsection 4.3, we show this 2-functor is an equivalence. Indeed, the 2-functor is essentially surjective on objects by [15] as explained at the beginning of Subsection 4.3, essentially surjective on 1-morphisms by Theorem 4.23, and fully faithful on 2-morphisms by Theorem 4.24. We defer all further proofs in this section to Appendix C. □

We thus have the following zig-zag of strict equivalences denoted \sim and an isomorphism \cong , where the hooked arrows denote inclusions of full subcategories.

$$3Cat_G \xleftarrow[\text{Thm. 3.4}]{\sim} 3Cat_G^{pt} \xleftarrow[\text{Cor. 3.5}]{\cong} 3Cat_G^{st} \xrightarrow[\text{Thm. 4.1}]{\sim} GCrsBrd^{st} \xleftarrow[\text{[27]}]{\sim} GCrsBrd$$

4.1 | Definitions

Let G be a group. We now give a definition of a (possibly non-additive) G -crossed braided category. Below, we give a definition in terms of the component categories \mathfrak{C}_g . When each component \mathfrak{C}_g is linear and the tensor product functors and G -action functors are linear, $\mathfrak{C} := \bigoplus_{g \in G} \mathfrak{C}_g$ is an ordinary G -crossed braided monoidal category in the sense of [22, section 8.24] (except possibly neither rigid nor fusion).

Definition 4.2. A G -monoidal category \mathfrak{C} consists of the following data:

- a collection of categories $(\mathfrak{C}_g)_{g \in G}$;
- a family of bifunctors $\otimes_{g,h} : \mathfrak{C}_g \times \mathfrak{C}_h \rightarrow \mathfrak{C}_{gh}$;
- an associator natural isomorphism $\alpha_{g,h,k} : \otimes_{gh,k} \circ (\otimes_{g,h} \times \text{id}_{\mathfrak{C}_k}) \Rightarrow \otimes_{g,hk} \circ (\text{id}_{\mathfrak{C}_g} \times \otimes_{h,k})$;
- a unit object $1_{\mathfrak{C}} \in \mathfrak{C}_e$;
- unitor natural isomorphisms $\lambda : \otimes_{e,g} \circ (1_{\mathfrak{C}} \times -) \Rightarrow \text{id}_{\mathfrak{C}_g}$ and $\rho : \otimes_{g,e} \circ (- \times 1_{\mathfrak{C}}) \Rightarrow \text{id}_{\mathfrak{C}_g}$.

Using the convention

$$a_g \otimes b_h := \otimes_{g,h}(a_g \times b_h) \quad \forall a_g \in \mathfrak{C}_g \text{ and } b_h \in \mathfrak{C}_h,$$

these data should satisfy the obvious pentagon and triangle axioms of a monoidal category.

Definition 4.3. A G -action on a G -monoidal category \mathfrak{C} consists of a functor $F_g : \mathfrak{C}_h \rightarrow \mathfrak{C}_{ghg^{-1}}$ for each $g \in G$ together with an isomorphism $i_g : 1_{\mathfrak{C}} \rightarrow F_g(1_{\mathfrak{C}})$ and natural isomorphisms ψ^g ,

$\mu^{g,h}$, and ι_g

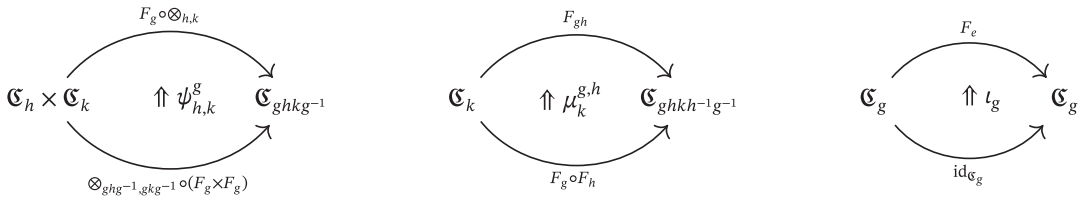

which satisfy the following associativity and unitality conditions where we suppress whiskering/labeling components of natural transformations, and we use the convention ‘ $F \otimes G$ ’ for $\otimes \circ (F \times G)$.

(ψ_1) (Associativity) For every $a_h \in \mathfrak{C}_h, b_k \in \mathfrak{C}_k$, and $c_\ell \in \mathfrak{C}_\ell$, the following diagram commutes:

$$\begin{array}{ccc}
 (F_g(a_h) \otimes F_g(b_k)) \otimes F_g(c_\ell) & \xrightarrow{\alpha} & F_g(a_h) \otimes (F_g(b_k) \otimes F_g(c_\ell)) \\
 \downarrow \psi_{h,k}^g \otimes \text{id}_{F_g(c_\ell)} & & \downarrow \text{id}_{F_g(b_k)} \otimes \psi_{k,\ell}^g \\
 F_g(a_h \otimes b_k) \otimes F_g(c_\ell) & & F_g(a_h) \otimes F_g(b_k \otimes c_\ell) \\
 \downarrow \psi_{h,k,\ell}^g & & \downarrow \psi_{h,k,\ell}^g \\
 F_g((a_h \otimes b_k) \otimes c_\ell) & \xrightarrow{\alpha} & F_g(a_h \otimes (b_k \otimes c_\ell))
 \end{array}$$

(ψ_2) (Unitality) For every $a_h \in \mathfrak{C}_h$, the following diagram commutes:

$$\begin{array}{ccc}
 1_{\mathfrak{C}} \otimes F_g(a_h) & \xrightarrow{i_g \otimes \text{id}_{F_g(a_h)}} & F_g(1_{\mathfrak{C}}) \otimes F_g(a_h) \\
 \downarrow \lambda_{F_g(a_h)} & & \downarrow \psi_{e,h}^g \\
 F_g(a_h) & \xleftarrow{F_g(\lambda_{a_h})} & F_g(1_{\mathfrak{C}} \otimes a_h)
 \end{array}$$

as does a similar diagram where $1_{\mathfrak{C}}$ appears on the right with ρ .

(μ_1) (Monoidality) For all $a_k \in \mathfrak{C}_k$ and $b_\ell \in \mathfrak{C}_\ell$, the following diagram commutes:

$$\begin{array}{ccc}
 F_g(F_h(a_k)) \otimes F_g(F_h(b_\ell)) & \xrightarrow{\psi_{hkh^{-1},h\ell h^{-1}}^g} & F_g(F_h(a_k \otimes b_\ell)) \\
 \downarrow \mu_k^{g,h} \otimes \mu_\ell^{g,h} & & \downarrow F_g(\psi_{k,\ell}^h) \\
 F_{gh}(a_k) \otimes F_{gh}(b_\ell) & & F_g(F_h(a_k \otimes b_\ell)) \\
 \swarrow \psi_{k,\ell}^{gh} & & \swarrow \mu_{k,\ell}^{g,h} \\
 & F_{gh}(a_k \otimes b_\ell) &
 \end{array}$$

(μ_2) (Associativity) For all $a_\ell \in \mathfrak{C}_\ell$, the following diagram commutes:

$$\begin{array}{ccc}
 F_g(F_h(F_k(c_\ell))) & \xrightarrow{F_g(\mu_\ell^{h,k})} & F_g(F_{hk}(c_\ell)) \\
 \downarrow \mu_{k\ell}^{g,h} & & \downarrow \mu_\ell^{g,hk} \\
 F_{gh}(F_k(c_\ell)) & \xrightarrow{\mu_\ell^{gh,k}} & F_{ghk}(c_\ell)
 \end{array}$$

(t1) (Monoidality) For all $a_h \in \mathfrak{C}_h$ and $b_k \in \mathfrak{C}_k$, the following diagram commutes:

$$\begin{array}{ccc}
 a_h \otimes b_k & \xrightarrow{l_{hk}} & F_e(a_h \otimes b_k) \\
 \searrow^{l_h \otimes l_k} & & \nearrow^{\psi_{h,k}^e} \\
 & F_e(a_h) \otimes F_e(b_k) &
 \end{array}$$

(t2) (Unitality) For all $a_h \in \mathfrak{C}_h$, the following diagrams commute:

$$\begin{array}{ccc}
 F_g(a_h) & \xrightarrow{l_{ghg^{-1}}} & F_e(F_g(a_h)) \\
 \searrow^{\mu_h^{e,g}} & & \nearrow^{\mu_h^{g,e}} \\
 & F_e(F_g(a_h)) &
 \end{array}
 \quad \text{and} \quad
 \begin{array}{ccc}
 F_g(a_h) & \xrightarrow{F_g(l_h)} & F_g(F_e(a_h)) \\
 \searrow^{\mu_h^{g,e}} & & \nearrow^{\mu_h^{e,g}} \\
 & F_g(F_e(a_h)) &
 \end{array}$$

Definition 4.4. A G -crossed braided category consists of a G -monoidal category equipped with a G -action and a G -crossed braiding natural isomorphism

$$\begin{array}{ccc}
 \mathfrak{C}_h \times \mathfrak{C}_g & \xrightarrow{\otimes_{ghg^{-1},g} \circ (F_g \times \text{id}_{\mathfrak{C}_g})} & \mathfrak{C}_{gh} \\
 \uparrow \text{swap} & \nearrow^{\beta^{g,h}} & \\
 \mathfrak{C}_g \times \mathfrak{C}_h & \xrightarrow{\otimes_{g,h}} & \mathfrak{C}_{gh}
 \end{array}
 \quad
 a_g \otimes b_h \xrightarrow{\beta_{a_g, b_h}^{g,h}} F_g(b_h) \otimes a_g \quad \forall a_g \in \mathfrak{C}_G, b_h \in \mathfrak{C}_h.$$

The G -action and G -crossed braiding are subject to the following coherence axioms taken from [22]. For all $a_g \in \mathfrak{C}_g, b_h \in \mathfrak{C}_h$, and $c_k \in \mathfrak{C}_k$, the following diagrams commute, where suppress all labels.

$$\begin{array}{ccc}
 F_g(b_h) \otimes F_g(c_k) & \xrightarrow{\quad} & F_{ghg^{-1}} F_g(c_k) \otimes F_g(b_h) \\
 \uparrow & & \downarrow \\
 F_g(b_h \otimes c_k) & & F_{gh}(c_k) \otimes F_g(b_h) \\
 \downarrow & & \uparrow \\
 F_g(F_h(c_k) \otimes b_h) & \xrightarrow{\quad} & F_g F_h(c_k) \otimes F_g(b_h) \\
 & & \uparrow \\
 & & (a_g \otimes b_h) \otimes c_k \\
 \swarrow & & \searrow \\
 a_g \otimes (b_h \otimes c_k) & & (F_g(b_h) \otimes a_g) \otimes c_k \\
 \downarrow & & \downarrow \\
 F_g(b_h \otimes c_k) \otimes a_g & & F_g(b_h) \otimes (a_g \otimes c_k) \\
 \downarrow & & \downarrow \\
 (F_g(b_h) \otimes F_g(c_k)) \otimes a_g & \xrightarrow{\quad} & F_g(b_h) \otimes (F_g(c_k) \otimes a_g)
 \end{array}
 \tag{\beta 1}$$

$$\begin{array}{ccc}
 & & (a_g \otimes b_h) \otimes c_k \\
 & \swarrow & \searrow \\
 a_g \otimes (b_h \otimes c_k) & & (F_g(b_h) \otimes a_g) \otimes c_k \\
 \downarrow & & \downarrow \\
 F_g(b_h \otimes c_k) \otimes a_g & & F_g(b_h) \otimes (a_g \otimes c_k) \\
 \downarrow & & \downarrow \\
 (F_g(b_h) \otimes F_g(c_k)) \otimes a_g & \xrightarrow{\quad} & F_g(b_h) \otimes (F_g(c_k) \otimes a_g)
 \end{array}
 \tag{\beta 2}$$

$$\begin{array}{ccc}
 & a_g \otimes (b_h \otimes c_k) & \\
 & \swarrow & \searrow \\
 (a_g \otimes b_h) \otimes c_k & & a_g \otimes (F_h(c_k) \otimes b_h) \\
 \downarrow & & \downarrow \\
 F_{gh}(c_k) \otimes (a_g \otimes b_h) & & (a_g \otimes F_h(c_k)) \otimes b_h \\
 \downarrow & & \downarrow \\
 F_g F_h(c_k) \otimes (a_g \otimes b_h) & \xrightarrow{\quad} & (F_g F_h(c_k) \otimes a_g) \otimes b_h
 \end{array} \tag{\beta 3}$$

Definition 4.5. Given two G -crossed braided categories \mathfrak{C} and \mathfrak{D} , a G -crossed braided functor $(\mathbf{A}, \mathbf{a}) : \mathfrak{C} \rightarrow \mathfrak{D}$ consists of a family of functors $(\mathbf{A}_g : \mathfrak{C}_g \rightarrow \mathfrak{D}_g)_{g \in G}$ together with a unitor isomorphism $\mathbf{A}^1 : 1_{\mathfrak{D}} \rightarrow \mathbf{A}(1_{\mathfrak{C}})$ and a tensorator natural isomorphism $\mathbf{A}^2_{a_g, b_h} : \mathbf{A}(a_g) \otimes \mathbf{A}(b_h) \rightarrow \mathbf{A}(a_g \otimes b_h)$ for all $a_g \in \mathfrak{C}_g$ and $b_h \in \mathfrak{C}_h$ satisfying the obvious coherences. The monoidal functor $\mathbf{A} = (\mathbf{A}_g, \mathbf{A}^1, \mathbf{A}^2)$ comes equipped with a family $\mathbf{a} = \{\mathbf{a}_g : F_g^{\mathfrak{D}} \circ \mathbf{A} \Rightarrow \mathbf{A} \circ F_g^{\mathfrak{C}}\}_{g \in G}$ of monoidal natural isomorphisms such that for all $g, h \in G$, the following diagrams commute, where we suppress whiskering from the notation.

$$\begin{array}{ccc}
 F_g^{\mathfrak{D}} \circ F_h^{\mathfrak{D}} \circ \mathbf{A} & \xrightarrow{\mu_{g,h}^{\mathfrak{D}}} & F_{gh}^{\mathfrak{D}} \circ \mathbf{A} \\
 \downarrow \mathbf{a}_h & & \downarrow \mathbf{a}_{gh} \\
 F_g^{\mathfrak{D}} \circ \mathbf{A} \circ F_h^{\mathfrak{C}} & & \mathbf{A} \circ F_{gh}^{\mathfrak{C}} \\
 \searrow \mathbf{a}_g & \nearrow \mu_{g,h}^{\mathfrak{C}} & \\
 & \mathbf{A} \circ F_g^{\mathfrak{D}} \circ F_h^{\mathfrak{C}} &
 \end{array} \tag{\gamma 1}$$

$$\begin{array}{ccc}
 \mathbf{A}(a) \otimes \mathbf{A}(b) & \xrightarrow{\mathbf{A}^2_{a,b}} & \mathbf{A}(a \otimes b) \\
 \downarrow \beta^{\mathfrak{D}} & & \downarrow \mathbf{A}(\beta^{\mathfrak{C}}) \\
 F_h^{\mathfrak{D}}(\mathbf{A}(b)) \otimes \mathbf{A}(a) & & \mathbf{A}(F_h^{\mathfrak{C}}(b) \otimes a) \\
 \searrow \mathbf{a}_h \otimes \text{id} & \nearrow \mathbf{A}^2_{F_h^{\mathfrak{C}}(b), a} & \\
 & \mathbf{A}(F_h^{\mathfrak{C}}(b)) \otimes \mathbf{A}(a) &
 \end{array} \tag{\gamma 2}$$

Definition 4.6. If $(\mathbf{A}, \mathbf{a}), (\mathbf{B}, \mathbf{b}) : \mathfrak{C} \rightarrow \mathfrak{D}$ are G -crossed braided functors, a G -crossed braided natural transformation $h : (\mathbf{A}, \mathbf{a}) \Rightarrow (\mathbf{B}, \mathbf{b})$ is a monoidal natural transformation $h : \mathbf{A} \Rightarrow \mathbf{B}$ such that for all $g \in G$, the following diagram commutes.

$$\begin{array}{ccc}
 F_g^{\mathfrak{D}} \circ \mathbf{A} & \xrightarrow{F_g^{\mathfrak{D}}(h_{(\cdot)})} & F_g^{\mathfrak{D}} \circ \mathbf{B} \\
 \downarrow \mathbf{a}_g & & \downarrow \mathbf{b}_g \\
 \mathbf{A} \circ F_g^{\mathfrak{C}} & \xrightarrow{h_{F_g^{\mathfrak{C}}(\cdot)}} & \mathbf{B} \circ F_g^{\mathfrak{C}}
 \end{array} \tag{18}$$

It is straightforward to verify that G -crossed braided categories, functors, and natural transformations assemble into a strict 2-category called $G\text{CrsBrd}$ with familiar composition formulae similar to those from the strict 2-category of monoidal categories. (See the proof of Proposition 4.15 in Appendix C for full details.)

Definition 4.7 Adapted from [27, p. 6]. A G -crossed braided category is called *strict* if α, λ, ρ are all identities, and all $i_g, \psi^g, \mu^{g,h}$, and ι^g are identities. Observe this implies that F_e is the identity as well.

By the main theorem of [27], every G -crossed braided category is equivalent (via a G -crossed braided functor which is an equivalence of categories) to a strict G -crossed braided category. In particular, the 2-category $G\text{CrsBrd}$ is equivalent to the full subcategory $G\text{CrsBrd}^{\text{st}}$ of strict G -crossed braided categories.

4.2 | A strict 2-functor $3\text{Cat}_G^{\text{st}}$ to $G\text{CrsBrd}^{\text{st}}$

In this section, we construct a strict 2-functor $3\text{Cat}_G^{\text{st}} \rightarrow G\text{CrsBrd}^{\text{st}}$. We begin by explaining how to obtain a strict G -crossed braided category \mathfrak{C} from an object $C \in 3\text{Cat}_G^{\text{st}}$, that is, C is a Gray-monoid with 0-cells $\{g_C\}_{g \in G}$ with 0-composition the group multiplication.

Construction 4.8. For each $g \in G$, we define the category $\mathfrak{C}_g := C(1_C \rightarrow g_C)$. We denote 1-cells in \mathfrak{C}_g by small disks. For better readability, we distinguish different 1-cells in a given diagram by different shadings of the corresponding disks. We will use the shorthand notation that white, green, and blue shaded disks correspond to 1-cells into g_C, h_C , and k_C , respectively:



We define the bifunctor $\otimes_{g,h} : \mathfrak{C}_g \times \mathfrak{C}_h \rightarrow \mathfrak{C}_{gh}$ by $- \otimes -$:

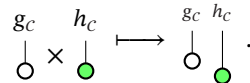

The associator $\otimes_{gh,k} \circ (\otimes_{g,h} \times \mathfrak{C}_k) \Rightarrow \otimes_{g,hk} \circ (\mathfrak{C}_g \times \otimes_{h,k})$ is the identity. The unit object $1_{\mathfrak{C}} := \text{id}_e \in \mathfrak{C}_e$, which we denote by a univalent vertex attached to a dashed string. The unitors $\otimes_{e,g} \circ (i \times -) \Rightarrow \text{id}_{\mathfrak{C}_g}$ and $\otimes_{g,e} \circ (- \times i) \Rightarrow \text{id}_{\mathfrak{C}_g}$ are also identities

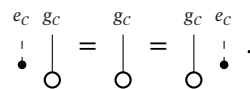

Clearly, the associators and unitors satisfy the obvious pentagon and triangle axioms of a G -crossed braided category.

Construction 4.9 (*G*-action). We define a *G*-action $F_g : \mathfrak{C}_h \rightarrow \mathfrak{C}_{ghg^{-1}}$ by

$$F_g \left(\begin{array}{c} h_c \\ | \\ \bullet \end{array} \right) := \begin{array}{c} g_c \quad h_c \quad g_c^{-1} \\ \cup \\ \bullet \end{array} =: \begin{array}{c} ghg_c^{-1} \\ | \\ \bullet \end{array} .$$

On the right-hand side, we abbreviate this ‘cup’ action by a single *g*-labeled red cup drawn under the respective node. The functors F_g are strict tensor functors, that is, the tensorators $\psi^g : \otimes_{ghg^{-1}, ghg^{-1}} \circ (F_g \times F_g) \Rightarrow F_g \circ \otimes_{h,k}$ are identity natural isomorphisms. The tensorator $\mu_{g,h} : F_g \circ F_h \Rightarrow F_{gh}$ and the unit map $\iota_h : \text{id}_{\mathfrak{C}_h} \rightarrow F_e$ are also both identities. It is straightforward to see that these identity natural isomorphisms $\psi^g, \mu^{g,h}$, and ι_h satisfy $(\psi 1), (\psi 2), (\mu 1), (\mu 2), (1), (2)$.

Construction 4.10 (*G*-crossed braiding). The *G*-crossed braiding natural isomorphisms $\beta^{g,h}$ are given by interchangers in \mathfrak{C} :

$$\begin{array}{c} g_c \quad h_c \\ | \quad | \\ \bullet \quad \bullet \end{array} \xrightarrow{\phi} \begin{array}{c} g_c \quad h_c \\ | \quad | \\ \bullet \quad \bullet \end{array} = \begin{array}{c} g_c \quad h_c \quad g_c^{-1} \quad g_c \\ \cup \\ \bullet \end{array} = \begin{array}{c} ghg_c^{-1} \quad h_c \\ | \quad | \\ \bullet \quad \bullet \end{array} .$$

Theorem 4.11. *The data $(\mathfrak{C}, \otimes_{g,h}, F_g, \beta^{g,h})$ from Constructions 4.8, 4.9, and 4.10 form a strict *G*-crossed braided category.* §C.1

Now suppose that $\mathfrak{C}, \mathfrak{D} \in 3\text{Cat}_G^{\text{st}}$ and $A \in 3\text{Cat}_G^{\text{st}}(\mathfrak{C} \rightarrow \mathfrak{D})$. This means $A(g_c) = g_D$ on the nose for all $g \in G$, the adjoint equivalence $\mu^A : \otimes_{\mathfrak{D}} \circ (A \times A) \Rightarrow A \circ \otimes_{\mathfrak{C}}$ satisfies $\mu_{g,h}^A = \text{id}_{gh} \in \mathcal{D}(g_D \otimes h_D \rightarrow gh_D)$, the adjoint equivalence $\iota^A : (\iota_*^A, \iota_1^A) : I_{\mathfrak{D}} \Rightarrow A \circ I_{\mathfrak{C}}$ satisfies $\iota_*^A = \text{id}_{e_D}$, and $\iota_1^A := A_e^1 \in \mathcal{D}(\text{id}_{e_D} \Rightarrow B(\text{id}_{e_C}))$, and the associators and unitors ω, ℓ, r are identities.

Let \mathfrak{C} and \mathfrak{D} be the strict *G*-crossed braided categories obtained from \mathfrak{C} and \mathfrak{D} , respectively, from Theorem 4.11. We now define a *G*-crossed braided functor $(\mathbf{A}, \mathbf{a}) : \mathfrak{C} \rightarrow \mathfrak{D}$.

Construction 4.12. First, for $a \in \mathfrak{C}_g := \mathcal{C}(e_C \rightarrow g_C)$, we define $\mathbf{A}(a) := A(a) \in \mathcal{D}(e_D \rightarrow g_D) = \mathfrak{D}_g$. For $x \in \mathfrak{C}_g (a \rightarrow b)$, we define $\mathbf{A}(x) := A(x) \in \mathfrak{D}_g (\mathbf{A}(a) \rightarrow \mathbf{A}(b))$. It is straightforward to verify \mathbf{A} is a functor. We now endow \mathbf{A} with a tensorator. For $a \in \mathfrak{C}_g$ and $b \in \mathfrak{C}_h$, we define $\mathbf{A}_{a,b}^2 \in \mathfrak{D}(\mathbf{A}(a) \otimes \mathbf{A}(b) \rightarrow \mathbf{A}(a \otimes b))$ to be

$$\mu_{a,b}^A : (A(a) \otimes \text{id}_h) \circ (\text{id}_e \otimes A(b)) \Rightarrow A((a \otimes \text{id}_h) \circ (\text{id}_e \otimes b)).$$

We define the unitor by $\mathbf{A}^1 := A_e^1 \in \mathfrak{D}(1_{\mathfrak{D}} \rightarrow \mathbf{A}(1_{\mathfrak{C}})) = \mathcal{D}(\text{id}_{e_D} \rightarrow A(\text{id}_{e_C}))$.

Lemma 4.13. *The data $(\mathbf{A}, \mathbf{A}^1, \mathbf{A}^2) : \mathfrak{C} \rightarrow \mathfrak{D}$ are *G*-graded monoidal functor.* §C.1

We now construct the compatibility \mathbf{a} between the *G*-actions on \mathfrak{C} and \mathfrak{D} . For $a \in \mathfrak{C}_h = \mathcal{C}(1_C \rightarrow h_C)$, we define $\mathbf{a}_g^a : F_g^{\mathfrak{D}}(\mathbf{A}(a)) \Rightarrow \mathbf{A}(F_g^{\mathfrak{C}}(a))$ using the tensorator μ^A :

$$\begin{aligned}
 F_g^{\mathfrak{D}}(\mathbf{A}(a)) &= \begin{array}{c} \text{Diagram 1: } \mathbf{A}(a) \text{ with } h_D \text{ and } g \text{ wires} \\ \xRightarrow{A^1_g} \text{Diagram 2: } A(\text{id}_{g_C}) \text{ and } A(a) \text{ with } g_D, h_D, g_D^{-1} \text{ wires} \\ \xRightarrow{\mu^A_{\text{id}_{g_C}, a}} \text{Diagram 3: } A(\text{id}_{g_C} \otimes a) \text{ with } g_D, h_D, g_D^{-1} \text{ wires} \\ \xRightarrow{A^1_{g_C^{-1}}} \text{Diagram 4: } A(\text{id}_{g_C} \otimes a) \text{ and } A(\text{id}_{g_C^{-1}}) \text{ with } g_D, h_D, g_D^{-1} \text{ wires} \\ \xRightarrow{\mu^A_{\text{id}_{g_C} \otimes a, \text{id}_{g_C^{-1}}}} \text{Diagram 5: } A(\text{id}_{g_C} \otimes a \otimes \text{id}_{g_C^{-1}}) \text{ with } h_D, g \text{ wires} \\ = \mathbf{A} \left(\begin{array}{c} \text{Diagram 6: } a \text{ with } h_C \text{ and } g \text{ wires} \end{array} \right) = \mathbf{A}(F_g^{\mathfrak{C}}(a)). \end{array} \tag{19}
 \end{aligned}$$

Theorem 4.14. *The data $(\mathbf{A}, \mathbf{A}^1, \mathbf{A}^2, \mathbf{a})$ are G -crossed braided monoidal functor.* §C.1

Proposition 4.15. *The map $(A, \mu^A, \iota^A) \mapsto (\mathbf{A}, \mathbf{a})$ strictly preserves identity 1-morphisms and composition of 1-morphisms.* §C.1

Suppose $C, D \in 3\text{Cat}_G^{\text{st}}$, $A, B \in 3\text{Cat}_G^{\text{st}}(C \rightarrow D)$, and $\eta \in 3\text{Cat}_G^{\text{st}}(A \Rightarrow B)$. This means that $\eta_* = e_D$ and $\eta_g = \text{id}_{g_D}$ for all $g \in G$. Let $\mathfrak{C}, \mathfrak{D}$ be the G -crossed braided categories obtained from C, D , respectively from Theorem 4.11. Let $(\mathbf{A}, \mathbf{a}), (\mathbf{B}, \mathbf{b}) : \mathfrak{C} \rightarrow \mathfrak{D}$ be the G -crossed braided functors obtained from A, B , respectively, from Theorem 4.14,

Construction 4.16. We define $h : (\mathbf{A}, \mathbf{a}) \Rightarrow (\mathbf{B}, \mathbf{b})$ by $h_a := \eta_a \in D(\mathbf{A}(a) \Rightarrow \mathbf{B}(a))$ for $a \in \mathfrak{C}_g = C(1_C \rightarrow g_C)$.

Theorem 4.17. *The data h define a G -crossed braided natural transformation $(\mathbf{A}, \mathbf{a}) \Rightarrow (\mathbf{B}, \mathbf{b})$.* §C.1

Theorem 4.18. *The map $C \mapsto (\mathfrak{C}, \otimes_{g,h}, F_g, \beta^{g,h}), (A, \mu^A, \iota^A) \mapsto (\mathbf{A}, \mathbf{a}), \eta \mapsto h$ is a strict 2-functor $3\text{Cat}_G^{\text{st}} \rightarrow \text{GCrsBrd}^{\text{st}}$.*

Proof. By Proposition 4.15, we saw that this candidate 2-functor strictly preserves identity 1-morphisms and composition of 1-morphisms. It remains to prove that the map $\eta \mapsto h$ preserves identities and 2-composition. This is immediate from Construction 4.16 as $(\eta * \zeta)_a = \eta_a * \zeta_a$ as $3\text{Cat}_G^{\text{st}}$ is strict. □

4.3 | The 2-functor is an equivalence

We now show our 2-functor $3\text{Cat}_G^{\text{st}} \rightarrow \text{GCrsBrd}^{\text{st}}$ constructed in Subsection 4.2 is an equivalence.

Essential surjectivity on objects

We begin by showing essential surjective, applying the techniques from [15]. Suppose \mathfrak{C} is a strict G -crossed braided category. We define a Gray-monoid $C \in 3\text{Cat}_G^{\text{st}}$ as follows. The 0-cells of C are

simply the elements of G , and 0-composition \otimes is the group multiplication. For $g, h \in G$, we define the hom category $C(g \rightarrow h) := \mathfrak{C}_{hg^{-1}}$. We endow C with the structure of a strict 2-category by defining the vertical composite of $a \in C(g \rightarrow h) = \mathfrak{C}_{hg^{-1}}$ and $b \in C(h \rightarrow k) = \mathfrak{C}_{kh^{-1}}$ as

$$b \circ_c a := b \otimes_{\mathfrak{C}} a = \otimes_{kh^{-1}, hg^{-1}}(b \times a).$$

It is straightforward to verify that C is a strict 2-category by strictness of the associator and unitor of \mathfrak{C} .

We now endow C with a monoidal product and interchanger. We define the monoidal product with identity 1-morphisms as follows. Given $a \in C(g \rightarrow h) = \mathfrak{C}_{hg^{-1}}$ and $k \in G$, we set

$$a \otimes \text{id}_k := a \in \mathfrak{C}_{hg^{-1}} = \mathfrak{C}_{hkk^{-1}g^{-1}} = C(gk \rightarrow hk),$$

that is, tensoring on the right with id_k does nothing. Tensoring on the left, however, implements the G -action:

$$\text{id}_k \otimes a := F_k(a) \in \mathfrak{C}(kgh^{-1}k^{-1}) = C(hg \rightarrow kh).$$

The interchanger ϕ is given by the G -crossed braiding. In more detail, given $a \in C(g \rightarrow h) = \mathfrak{C}_{hg^{-1}}$ and $b \in C(k \rightarrow \ell)_{\ell k^{-1}}$, we define

$$\phi_{a,b} := \beta_{a,b}^{hg^{-1}, g\ell k^{-1}\ell^{-1}} \in C((a \otimes \text{id}_{\ell}) \circ (\text{id}_g \otimes b) \Rightarrow (\text{id}_h \otimes b) \circ (a \otimes \text{id}_k)).$$

Indeed, since \mathfrak{C} is strict, $F_{hg^{-1}} = F_h F_{g^{-1}}$ on the nose, and $\beta^{hg^{-1}, g\ell k^{-1}\ell^{-1}}$ is a natural isomorphism

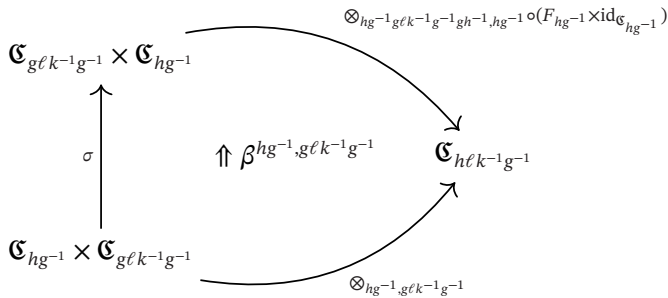

Notation 4.19. In the graphical calculus, one can think of a 1-cell in $C(g \rightarrow h)$ as a 1-cell in $C(1_C \rightarrow hg^{-1})$ with a g -strand on the right-hand side, which does nothing.

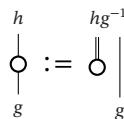

Vertical composition is then given by

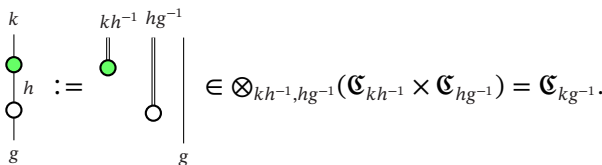

Tensoring by an identity strand on the right adds a strand on the right which does nothing, whereas tensoring by an identity on the left implements the G -action.[†]

$$\begin{array}{c} h \\ \circ \\ | \\ g \end{array} \otimes \begin{array}{c} k \\ | \\ k \end{array} := \begin{array}{c} h \ k \\ \circ \quad | \\ | \quad | \\ g \quad k \end{array} := \begin{array}{c} hg^{-1} \\ \circ \\ | \\ gk \end{array} \in \mathfrak{C}_{hg^{-1}} \qquad \begin{array}{c} g \\ | \\ g \end{array} \otimes \begin{array}{c} k \\ \circ \\ | \\ h \end{array} := \begin{array}{c} k \\ | \\ g \end{array} := \begin{array}{c} kh^{-1} \\ \circ \\ | \\ gh \end{array} \in \mathfrak{C}_{gkh^{-1}g^{-1}}.$$

That the interchanger is given by the G -crossed braiding can now be represented graphically by

$$\begin{array}{c} h \\ \circ \\ | \\ g \end{array} \begin{array}{c} \ell \\ | \\ k \end{array} = \begin{array}{c} hg^{-1} \\ \circ \\ | \\ g \end{array} \begin{array}{c} \ell k^{-1} \\ | \\ k \end{array} = \begin{array}{c} hg^{-1} \ \ell k^{-1} \\ \circ \quad | \\ | \quad | \\ g \quad k \end{array} \xrightarrow{\beta^{hg^{-1}, g\ell k^{-1}g^{-1}}} \begin{array}{c} \ell k^{-1} \ hg^{-1} \\ h \quad | \\ | \quad | \\ gk \end{array} = \begin{array}{c} h \\ \circ \\ | \\ g \end{array} \begin{array}{c} \ell \\ | \\ k \end{array}.$$

One then checks that \mathcal{C} defined as above is a Gray-monoid and thus defines an object of $3\text{Cat}_G^{\text{st}}$. Indeed, the verification is entirely similar to [15] (see also [19, Construction 2.1.23]). Moreover, applying our construction from Theorem 4.11 to the so defined \mathcal{C} , recovers the G -crossed braided category \mathfrak{C} on the nose. Hence, the strict 2-functor $3\text{Cat}_G^{\text{st}} \rightarrow G\text{CrSBrd}^{\text{st}}$ is in fact strictly surjective on objects.

Essential surjectivity on 1-morphisms

Let $\mathfrak{C}, \mathfrak{D}$ be the G -crossed braided categories obtained from $\mathcal{C}, \mathcal{D} \in 3\text{Cat}_G^{\text{st}}$, respectively, from Theorem 4.11, and suppose $(\mathbf{A}, \mathbf{a}) : \mathfrak{C} \rightarrow \mathfrak{D}$ is a G -crossed braided functor. We now construct an $A \in 3\text{Cat}_G^{\text{st}}(\mathcal{C} \rightarrow \mathcal{D})$ which maps to (\mathbf{A}, \mathbf{a}) under Construction 4.12 and (19).

Construction 4.20. First, we must have $A(g_C) = g_D$ for all $g \in G$. Recall that we have an isomorphism of categories $\mathcal{C}(g_C \rightarrow h_C) \cong \mathcal{C}(1_C \rightarrow hg_C^{-1})$ given by the strict 2-functor $R_{g_C^{-1}} = - \otimes g_C^{-1}$. For a 1-cell $x \in \mathcal{C}(g_C \rightarrow h_C)$, we define $A(x) := \mathbf{A}(x \otimes g_C^{-1}) \otimes g_D$, and similarly for 2-cells $f \in \mathcal{C}(x \rightarrow y)$. We define the unitor

$$A_g^1 := \mathbf{A}_e^1 \otimes g_D \in \mathcal{D}(\text{id}_{g_D} \Rightarrow A(\text{id}_{g_C}) = \mathbf{A}(\text{id}_{e_C}) \otimes g_D),$$

and for $x \in \mathcal{C}(g_C \rightarrow h_C)$ and $y \in \mathcal{C}(h_C \rightarrow k_C)$, the compositor $A_{y,x}^2$ as the composite

$$\begin{aligned}
 A(y) \circ A(x) &= (\mathbf{A}(y \otimes h_C^{-1}) \otimes h_D) \circ (\mathbf{A}(x \otimes g_C^{-1}) \otimes g_D) \\
 &= (\mathbf{A}(y \otimes h_C^{-1}) \otimes hg_D^{-1} \otimes g_D) \circ (\mathbf{A}(x \otimes g_C^{-1}) \otimes g_D) \\
 &= ((\mathbf{A}(y \otimes h_C^{-1}) \otimes hg_D^{-1}) \circ (\mathbf{A}(x \otimes g_C^{-1}))) \otimes g_D && - \otimes g_D \text{ strict} \\
 &= ((\mathbf{A}(y \otimes h_C^{-1}) \otimes \mathbf{A}(x \otimes g_C^{-1}))) \otimes g_D && \text{Nudging (8)} \\
 &\xrightarrow{A^2} (\mathbf{A}((y \otimes h_C^{-1}) \otimes (x \otimes g_C^{-1}))) \otimes g_D \\
 &= (\mathbf{A}((y \otimes h_C^{-1} \otimes hg_C^{-1}) \circ (x \otimes g_C^{-1}))) \otimes g_D && \text{Nudging (8)}
 \end{aligned}$$

[†] This graphical calculus is analogous to diagrams for endomorphisms of a von Neumann algebra or a Cuntz C^* -algebra explained in [39, section 2] where adding a strand labeled by an endomorphisms of a von Neumann algebra on the right does nothing, and adding a strand on the left implements the action of that endomorphism.

$$\begin{aligned}
 &= (\mathbf{A}((y \otimes g_C^{-1}) \circ (x \otimes g_C^{-1}))) \otimes g_D \\
 &= (\mathbf{A}((y \circ x) \otimes g_C^{-1})) \otimes g_D && - \otimes g_C^{-1} \text{ strict} \\
 &= A(y \circ x).
 \end{aligned}$$

Lemma 4.21. *The data (A, A^1, A^2) define a 2-functor $C \rightarrow D$ such that $A(g_C) = g_D$ for all $g \in G$. §C.2*

Construction 4.22. The adjoint equivalence $\mu^A : \otimes_D \circ (A \times A) \Rightarrow A \circ \otimes_C$ is defined as follows. First, $\mu_{g,h}^A := \text{id}_{gh_D} \in \mathcal{D}(g_D \otimes h_D \Rightarrow gh_D)$. For $x \in \mathcal{C}(g_C \rightarrow h_C)$ and $y \in \mathcal{C}(k_C \rightarrow \ell_C)$, we define the natural isomorphism $\mu_{x,y}^A \in \mathcal{D}(A(x) \otimes A(y) \Rightarrow A(x \otimes y))$ by the composite

$$\begin{aligned}
 A(x) \otimes A(y) &= \mathbf{A}(x \otimes g_C^{-1}) \otimes g_D \otimes \mathbf{A}(y \otimes k_C^{-1}) \otimes k_D \\
 &= \mathbf{A}(x \otimes g_C^{-1}) \otimes F_g^{\mathfrak{D}}(\mathbf{A}(y \otimes k_C^{-1})) \otimes g_D \otimes k_D \\
 &= \mathbf{A}(x \otimes g_C^{-1}) \otimes F_g^{\mathfrak{D}}(\mathbf{A}(y \otimes k_C^{-1})) \otimes gk_D \\
 &\xrightarrow{\mathbf{a}} \mathbf{A}(x \otimes g_C^{-1}) \otimes \mathbf{A}(F_g^{\mathfrak{G}}(y \otimes k_C^{-1})) \otimes gk_D \\
 &\xrightarrow{\mathbf{A}^2} \mathbf{A}(x \otimes g_C^{-1} \otimes F_g^{\mathfrak{G}}(y \otimes k_C^{-1})) \otimes gk_D \\
 &= \mathbf{A}(x \otimes F_{g^{-1}}^{\mathfrak{G}} F_g^{\mathfrak{G}}(y \otimes k_C^{-1}) \otimes g_C^{-1}) \otimes gk_D \\
 &= \mathbf{A}(x \otimes F_e^{\mathfrak{G}}(y \otimes k_C^{-1}) \otimes g_C^{-1}) \otimes gk_D \\
 &= \mathbf{A}(x \otimes y \otimes k_C^{-1} \otimes g_C^{-1}) \otimes gk_D \\
 &= \mathbf{A}(x \otimes y \otimes (gk)_C^{-1}) \otimes gk_D \\
 &= A(x \otimes y).
 \end{aligned}$$

The adjoint equivalence $\iota^A = (\iota_*^A, \iota_1^A) : I_D \Rightarrow A \circ I_C$ is defined by $\iota_*^A := \text{id}_{e_D}$, $\iota_1^A := A e_C^1$. The associator ω^A and the unitors ℓ^A, r^A are all defined to be identities.

Theorem 4.23. *The data (A, μ^A, ι^A) define a 1-morphism in $3\text{Cat}_G^{\text{st}}(C \rightarrow D)$. §C.2*

Finally, we observe that the G -crossed braided functor constructed from A in Theorem 4.14 is exactly (\mathbf{A}, \mathbf{a}) by construction. Indeed, the strict 2-functors $- \otimes e_C$ and $- \otimes e_D$ are the identity on the nose. Hence, $3\text{Cat}_G^{\text{st}} \rightarrow \text{GCrsBrd}^{\text{st}}$ is in fact surjective on 1-morphisms on the nose.

Fully faithfulness on 2-morphisms

For $C, D \in 3\text{Cat}_G^{\text{st}}$, $A, B \in 3\text{Cat}_G^{\text{st}}(C \rightarrow D)$, and $\eta \in 3\text{Cat}_G^{\text{st}}(A \Rightarrow B)$, let $\mathfrak{C}, \mathfrak{D}$ be the G -crossed braided categories obtained from C, D , respectively, from Theorem 4.11, and let $(\mathbf{A}, \mathbf{a}), (\mathbf{B}, \mathbf{b}) : \mathfrak{C} \rightarrow \mathfrak{D}$ be the G -crossed braided functors obtained from A, B , respectively, from Theorem 4.14. In Construction 4.16, we defined $h : (\mathbf{A}, \mathbf{a}) \Rightarrow (\mathbf{B}, \mathbf{b})$ by $h_a := \eta_a \in \mathcal{D}(\mathbf{A}(a) \Rightarrow \mathbf{B}(a))$ for $a \in \mathfrak{C}_g = \mathcal{C}(1_C \rightarrow g_C)$.

Theorem 4.24. *The map $\eta \mapsto h$ is a bijection $3\text{Cat}_G^{\text{st}}(A \Rightarrow B) \rightarrow \text{GCrsBrd}^{\text{st}}(\mathbf{A} \Rightarrow \mathbf{B})$. §C.2*

5 | INDUCED PROPERTIES AND STRUCTURES

Theorem A constructs an equivalence between G -crossed braided categories and 1-surjective G -pointed 3-categories. In this section, we investigate how various additional structures and properties of 3-categories, such as linearity and dualizability, translate into the corresponding properties of G -crossed braided categories. Let $\pi^C : BG \rightarrow C$ be a 1-surjective G -pointed 3-category and let $\{\mathfrak{C}_g\}_{g \in G}$ be the corresponding G -crossed braided category constructed via Theorem A.

The first result below is immediate.

Proposition 5.1 (Linearity). *If C is a linear 3-category, then $\mathfrak{C} := \bigoplus_{g \in G} \mathfrak{C}_g$ is a G -crossed braided category in these sense of [22, section 8.24].* □

Following the conventions in [20, Definitions 2.1.1, 2.1.2, 2.1.4], given a 1-morphism $f : c \rightarrow d$ in a 2-category, we write $(f^L : d \rightarrow c, \text{ev}_f : f^L \circ f \Rightarrow \text{id}_c, \text{coev}_f : \text{id}_d \Rightarrow f \circ f^L)$ for the left adjoint of f and $(f^R : d \rightarrow c, {}_f \text{ev} : f \circ f^R \Rightarrow \text{id}_d, {}_f \text{coev} : \text{id}_c \Rightarrow f^R \circ f)$ for its right adjoint. Given an object x in a monoidal category \mathfrak{M} , we write $(x^\vee, \text{ev}_x : x^\vee \otimes x \rightarrow 1_{\mathfrak{M}}, \text{coev}_x : 1_{\mathfrak{M}} \rightarrow x \otimes x^\vee)$ for the right dual of x , and $({}^\vee x, {}_x \text{ev} : x \otimes {}^\vee x \rightarrow 1_{\mathfrak{M}}, {}_x \text{coev} : 1_{\mathfrak{M}} \rightarrow {}^\vee x \otimes x)$ for the left dual of x .

Recall that a braided monoidal category has right duals if and only if it has left duals.

Lemma 5.2. *A G -crossed braided monoidal category $\mathfrak{C} = \bigoplus_{g \in G} \mathfrak{C}_g$ has right duals if and only if it has left duals.*

Proof. We prove that having right duals implies having left duals; the other direction is analogous. Suppose $x \in \mathfrak{C}_g$ has a right dual $(x^\vee \in \mathfrak{C}_{g^{-1}}, \text{ev}_x : x^\vee \otimes x \rightarrow 1_{\mathfrak{C}}, \text{coev}_x : 1_{\mathfrak{C}} \rightarrow x \otimes x^\vee)$. Then, ${}^\vee x := g^{-1}(x^\vee)$ is a left dual with the following evaluation and coevaluation morphism:

$$\begin{aligned} x \text{ ev} &:= \text{ev}_x \circ (\mu_{g, g^{-1}}^x \otimes \text{id}_{x^\vee}) \circ (\beta_{x, g^{-1}(x^\vee)}): x \otimes g^{-1}(x^\vee) \rightarrow 1_{\mathfrak{C}} \\ {}_x \text{ coev} &:= \beta_{g^{-1}(x^\vee), x}^{-1} \circ \psi_{x, x^\vee}^{g^{-1}} \circ g^{-1}(\text{coev}_x): 1_{\mathfrak{C}} \rightarrow {}^\vee x \otimes x \end{aligned}$$

That these maps satisfy the zig-zag/snake equations is straightforward. □

Remark 5.3. Similar to Lemma 5.2, every 2-morphism between invertible 1-morphisms (or more generally, between fully dualizable 1-morphisms) in a 3-category has a right adjoint if and only if it has a left adjoint [51, Proposition A.2].

Proposition 5.4 (Rigidity). *Suppose C is linear so that Proposition 5.1 holds. If every 2-morphism in $C(\pi^C(e) \rightarrow \pi^C(g))$ has either a right or a left adjoint (and thus necessarily both by Remark 5.3) for all $g \in G$, then the G -crossed braided linear monoidal category \mathfrak{C} is rigid.*

Proof. As the statement and the assumptions in this proposition are invariant under equivalences in 3Cat_G and $G\text{CrBrd}$, respectively, we may assume that C is an object of $3\text{Cat}_G^{\text{st}}$, and hence the delooping $\mathcal{B}\mathcal{A}$ of a Gray-monoid \mathcal{A} whose set of 0-cells is $\{g_{\mathcal{A}}\}_{g \in G}$ with 0-composition \otimes the group multiplication, and that \mathfrak{C} is the strict G -crossed braided category obtained from Constructions 4.8–4.10.

By Lemma 5.2 it suffices to prove that for every $g \in G$, every object $x \in \mathfrak{C}_g$ (given by a 1-cell $x : 1_{\mathcal{A}} \rightarrow g_{\mathcal{A}}$ in the strict 2-category \mathcal{A}) has either a right dual or a left dual. We assume the underlying 1-cell $x : 1_{\mathcal{A}} \rightarrow g_{\mathcal{A}}$ has a left adjoint $x^L : g_{\mathcal{A}} \rightarrow 1_{\mathcal{A}}$ in the 2-category \mathcal{A} and prove that the corresponding object $x \in \mathfrak{C}_g$ has a right dual in the monoidal category \mathfrak{C} . We use the shorthand notation

$$\circ := \begin{array}{c} g_c \\ \circlearrowleft \\ x \end{array} \quad \circ := \begin{array}{c} \circlearrowright \\ x^L \\ g_c \end{array}$$

Setting

$$x^\vee := \begin{array}{c} g_c^{-1} \\ \circlearrowleft \\ \circlearrowright \\ g_c \end{array} = \begin{array}{c} g_c^{-1} \\ \circlearrowright \\ \circlearrowleft \\ g_c \end{array} \in \mathfrak{C}_{g^{-1}},$$

it is a direct consequence of the adjunction between x and x^L (here denoted $\varepsilon : x^L \circ x \Rightarrow \text{id}_{e_c}$ and $\eta : \text{id}_{g_c} \Rightarrow x \circ x^L$) that the following evaluation and coevaluation morphisms exhibit x^\vee as a right dual of x :

$$\begin{aligned} \text{ev}_x : x^\vee \otimes x &= \begin{array}{c} g_c^{-1} \quad g_c \\ \circlearrowleft \quad \circlearrowright \\ \circlearrowright \quad \circlearrowleft \\ g_c \end{array} = \begin{array}{c} e_c \\ \circlearrowright \\ \circlearrowleft \end{array} \xRightarrow{\varepsilon} \begin{array}{c} e_c \\ \square \\ \end{array} = 1_{\mathfrak{C}} \\ \text{coev}_x : 1_{\mathfrak{C}} &= \begin{array}{c} e_c \\ \square \\ \circlearrowright \quad \circlearrowleft \\ g_c \quad g_c^{-1} \end{array} \xRightarrow{\eta} \begin{array}{c} g_c \quad g_c^{-1} \\ \circlearrowright \\ \circlearrowleft \\ g_c \end{array} = x \otimes x^\vee. \end{aligned}$$

We explicitly prove the relation $(\text{id}_x \otimes \text{ev}_x) \circ (\text{coev}_x \otimes \text{id}_x) = \text{id}_x$; the other relation is left to the reader.

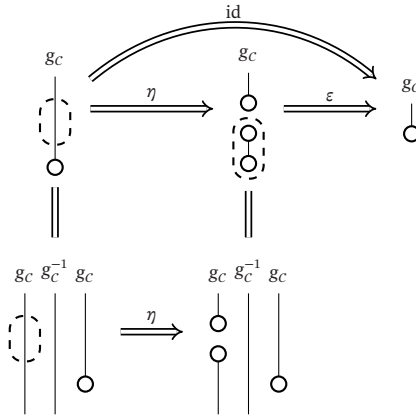

In the diagram above, the composite $(\text{id}_x \otimes \text{ev}_x) \circ \alpha \circ (\text{coev}_x \otimes \text{id}_x)$ is the path going down and then to the right. The square commutes as both maps are identical. The triangle commutes by the adjunction. □

Remark 5.5. There is a version of Proposition 5.4 that holds in the non-linear setting; one must be careful to define the correct notion of duals.

The following proposition is also immediate.

Proposition 5.6 (Multifusion). *Suppose C is as in the hypotheses of Proposition 5.4 so that \mathfrak{C} is rigid linear monoidal. If each 2-morphism category $C(\pi^C(e) \rightarrow \pi^C(g))$ is semisimple, then \mathfrak{C} is multifusion. If moreover the 2-morphism $\text{id}_{\pi^C(e)} : \pi^C(e) \rightarrow \pi^C(e)$ is simple, then \mathfrak{C} is fusion. \square*

Since the fusion 2-categories of [19] satisfy the hypotheses of Proposition 5.6, we get the following corollary.

Corollary 5.7. *If C is a fusion 2-category in the sense of [19] and $\pi : G \rightarrow C$ is a monoidal 2-functor which is essentially surjective on objects, then \mathfrak{C} is a G -crossed braided fusion category. \square*

Remark 5.8 (Unitarity). We define a dagger structure on a Gray-monoid C in terms of the unpacked Definition 2.4. We require the strict 2-category C to be a dagger 2-category, all 2-functors to be dagger 2-functors, and all isomorphisms to be unitary. Similarly, one can define the notion of a C^* or W^* Gray-monoid. Given a dagger Gray-monoid C and an appropriately compatible G action on C (all actions are by dagger functors and all isomorphisms are unitary), we expect our construction will yield a G -crossed braided dagger category. We expect analogous results in the C^* and W^* settings. However, the notion of dagger Gray-monoid is not compatible with weak equivalences and Gray-ification. These notions merit further study.

Remark 5.9 (Pivotality). We expect that an appropriately weakened version of a spatial pivotal structure on a Gray-monoid C (in the sense of [4]) and an appropriately compatible G -action on C induces a spherical pivotal structure on the G -crossed braided monoidal category \mathfrak{C} constructed from C and its G -action.

APPENDIX A: FUNCTORS AND HIGHER MORPHISMS BETWEEN Gray-MONOIDS

In this section, we unpack the definitions of trihomomorphism, tritransformation, trimodification, and perturbation of [35, Definitions 4.10, 4.16, 4.18, 4.21] between two Gray-monoids in terms of the graphical calculus.

We remind the reader that as in Notation 2.3, given a Gray-monoid C , we refer to its objects, 1-morphisms, and 2-morphisms as 0-cells, 1-cells, and 2-cells, respectively, in order to distinguish these basic components of C from morphisms in an ambient category in which C lives. The notion of adjoint equivalence in a 2-category is well-known, so we will not unpack it further. A *biadjoint biequivalence* [34] 0-cell α in a Gray-monoid consists of 0-cells α_*, α_*^{-1} which we depict in the graphical calculus as oriented red strands:



and cup and cap 1-morphisms



together with 2-isomorphisms

fulfilling certain coherence conditions; see [34, Definitions 2.1 and 2.3, Remark 2.2].

A.1 | 3-Functors between Gray-monoids

Definition A.1. Suppose C, D are Gray-monoids. A 3-functor $A : BC \rightarrow BD$ consists of the following.

(F-I) A 2-functor $(A, A^1, A^2) : C \rightarrow D$. That is, a function on globular sets A , an invertible 2-cell $A^1_c : \text{id}_{A(c)} \Rightarrow A(\text{id}_c)$, and an invertible 2-cell $A^2_{y,x} : A(y) \circ A(x) \Rightarrow A(y \circ x)$, which satisfy the following coherence conditions.

(F-I).i For all $x \in C(a \rightarrow b)$, $y \in C(b \rightarrow c)$, and $z \in C(c \rightarrow d)$, the following diagram commutes:

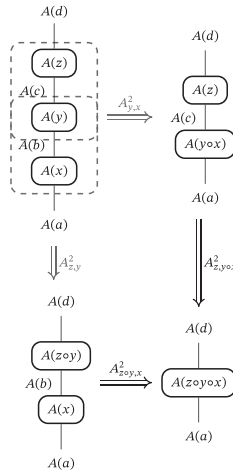

(F-I).ii For all $x \in C(a \rightarrow b)$, the following two triangles commute:

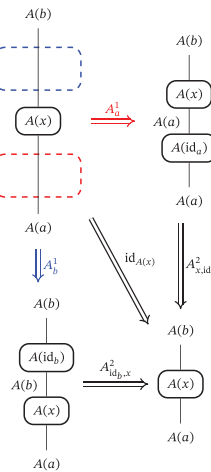

(F-II) An adjoint equivalence $\mu^A : \otimes_D \circ (A \times A) \Rightarrow A \circ \otimes_C$ in the 2-category of 2-functors $C \times C \rightarrow D$. Explicitly, this is given by, for each pair of 0-cells $(a, b) \in C \times C$, an adjoint equivalence 1-cell $\mu_{a,b}^A : A(a) \otimes A(b) \rightarrow A(a \otimes b)$ and for each pair of 1-cells $(x, y) : (a, b) \rightarrow (c, d)$, an invertible 2-cell

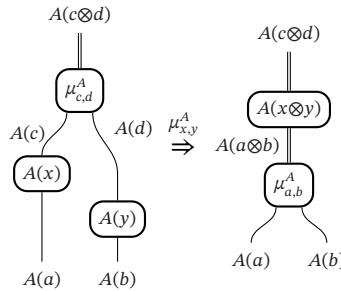

That μ^A is a 2-transformation means we have the following coherences.

(F-II).i For all $x, x' : a \rightarrow c$ and $y, y' : b \rightarrow d$ and all $f : x \Rightarrow x'$ and $g : y \Rightarrow y'$, the following square commutes:

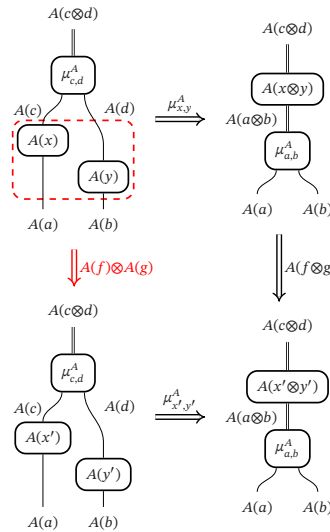

(F-II).ii For all 1-cells $x_1 \in C(a_1 \rightarrow a_2)$, $x_2 \in C(a_2 \rightarrow a_3)$, $y_1 \in C(b_1 \rightarrow b_2)$, and $y_2 \in C(b_2 \rightarrow b_3)$,

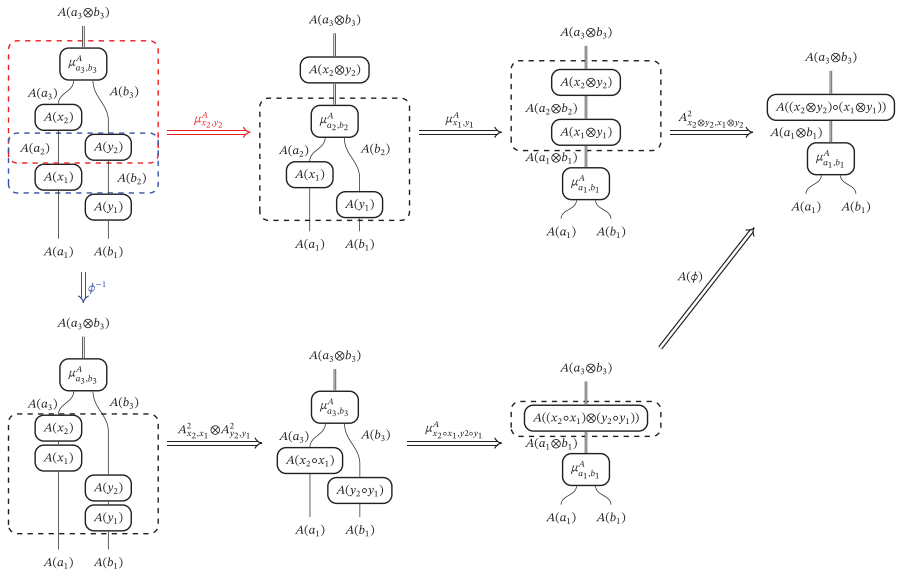

(F-II).iii For all 0-cells $a, b \in \mathcal{C}$, the following diagram commutes:

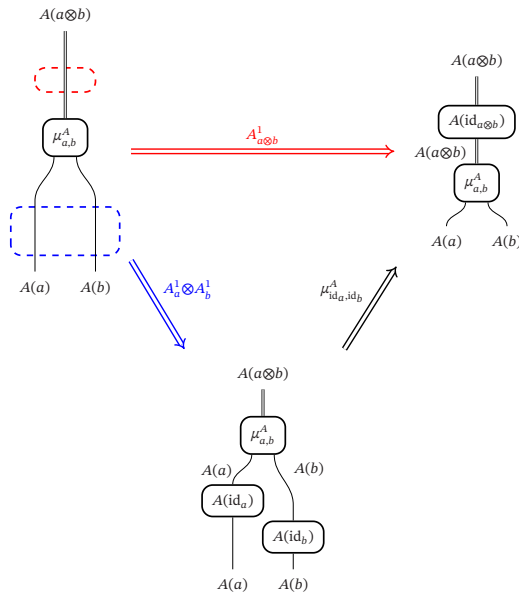

(F-III) An adjoint equivalence $\iota^A : I_{\mathcal{D}} \Rightarrow A \circ I_{\mathcal{C}}$ (in the 2-category of 2-functors $* \rightarrow \mathcal{D}$) where $I_{\mathcal{C}} : * \rightarrow \mathcal{C}$ is the inclusion of the trivial 2-category into \mathcal{C} which picks out $1_{\mathcal{C}}, \text{id}_{1_{\mathcal{C}}}, \text{id}_{\text{id}_{1_{\mathcal{C}}}}$, and similarly for \mathcal{D} . Explicitly, this is given by an adjoint equivalence 1-cell $\iota_*^A : 1_{\mathcal{D}} \rightarrow A(1_{\mathcal{C}})$ and an invertible 2-cell

$$\left(\begin{array}{c} A(1_C) \\ \downarrow \\ \textcircled{\iota_1^A} \end{array} \Rightarrow \begin{array}{c} A(1_C) \\ \downarrow \\ \textcircled{A(\text{id}_{1_C})} \\ \downarrow \\ A(1_C) \\ \downarrow \\ \textcircled{\iota_1^A} \end{array} \right) = \left(\begin{array}{c} A(1_C) \\ \downarrow \\ \textcircled{\iota_1^A} \end{array} \Rightarrow \begin{array}{c} A(1_C) \\ \downarrow \\ \textcircled{A(\text{id}_{1_C})} \\ \downarrow \\ A(1_C) \\ \downarrow \\ \textcircled{\iota_1^A} \end{array} \right).$$

That ι^A is a 2-transformation implies that ι_1^A equals the map on the right-hand side above, which is a whiskering with A_1^1 . This means ι_1^A is automatically natural and compatible with A^2 .

(F-IV) An invertible associator 2-modification ω^A . Explicitly, this is given by, for each $a, b, c \in \mathcal{C}$, an invertible 2-cell

and the fact that ω is a 2-modification means that for all $x \in \mathcal{C}(a_1 \rightarrow a_2)$, $y \in \mathcal{C}(b_1 \rightarrow b_2)$, and $z \in \mathcal{C}(c_1 \rightarrow c_2)$,

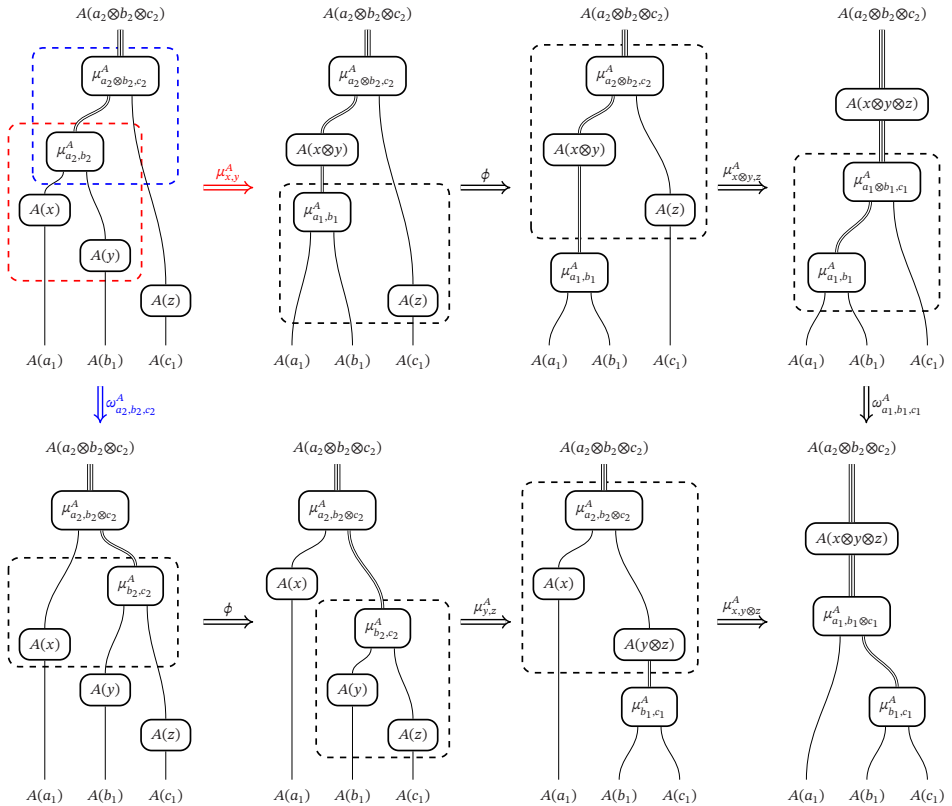

(F-V) Invertible unitor 2-modifications ℓ^A and r^A , that is, for each $c \in C$, invertible 2-cells

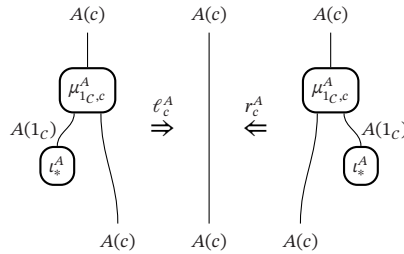

The fact that ℓ and r are 2-modifications means that for all $x \in C(a \rightarrow b)$, the following diagram commutes:

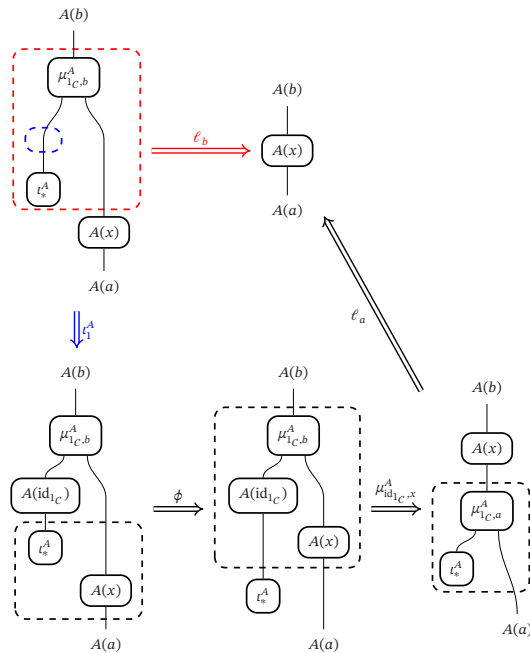

and a similar condition for r .

These data are subject to the additional two coherence conditions, cf. [35, Definition 4.10]:

(F-1) For all $a, b, c, d \in C$, the following diagram commutes:

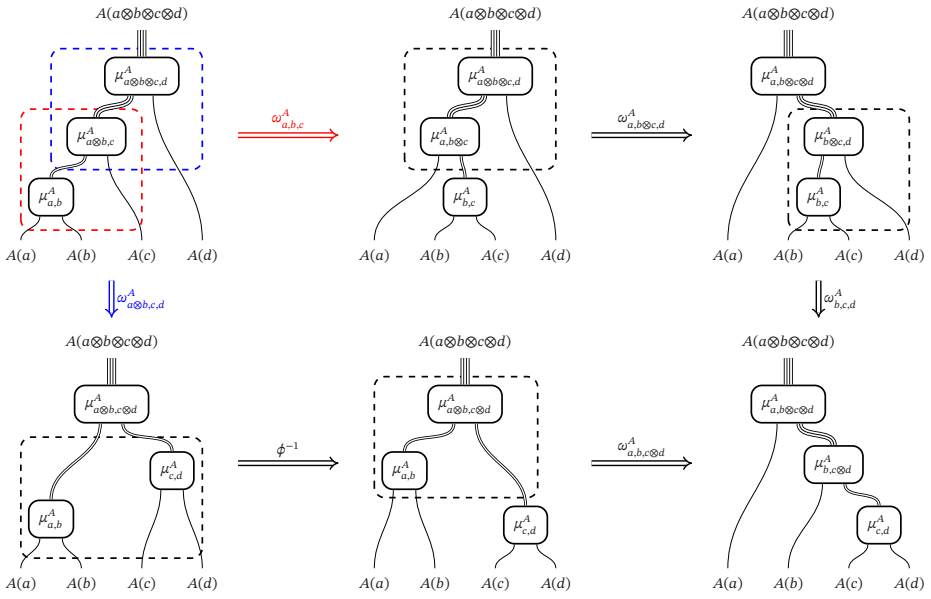

(F-2) For all $a, b, c \in C$, the following diagram commutes:

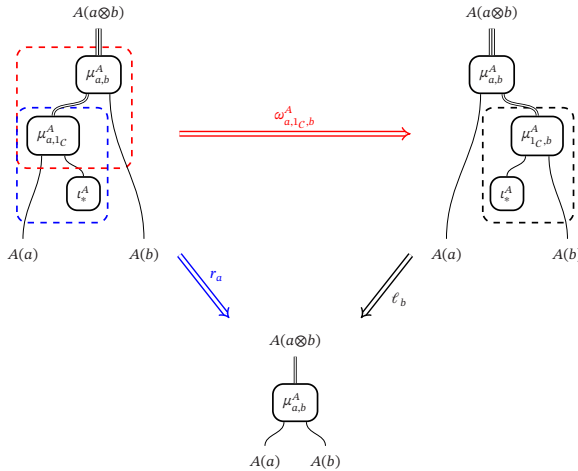

A.2 | Transformations between functors of Gray-monoids

Definition A.2. Suppose C, D are Gray-monoids and $A, B : BC \rightarrow BD$ are 3-functors. A transformation $\eta : A \Rightarrow B$ consists of the following.

- (T-I) An object $\eta_* \in D$, which we depict by an oriented green strand:
- (T-II) An adjoint equivalence $\eta : D(\text{id}, \eta_*) \circ A \Rightarrow D(\eta_*, \text{id}) \circ B$ in the 2-category of 2-functors $C \rightarrow D$. Explicitly, this is given by, for each $c \in C$, an adjoint equivalence 1-cell $\eta_c : \eta_* \otimes$

$A(c) \Rightarrow B(c) \otimes \eta_*$ which we depict as a crossing

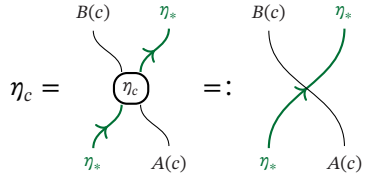

together with, for each $x \in C(a \rightarrow b)$, invertible 2-cells

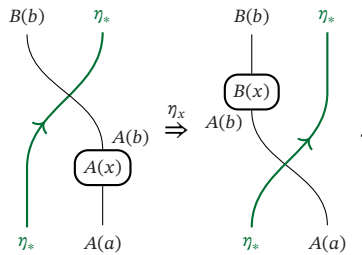

The fact that η is a 2-natural transformation means that:

(T-II).i for every $x, y \in C(a \rightarrow b)$ and $f \in C(x \Rightarrow y)$, the following diagram commutes:

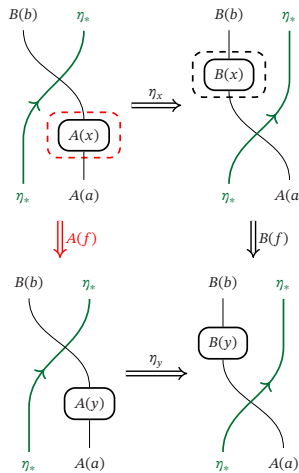

(T-II).ii for every $x \in C(a \rightarrow b)$ and $y \in C(b \rightarrow c)$, the following diagram commutes:

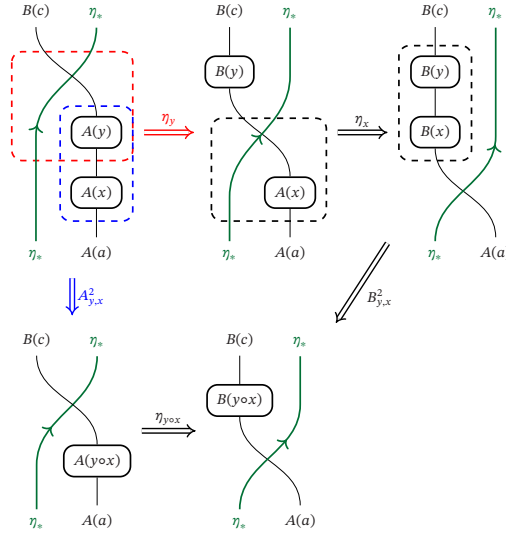

(T-II).iii for every $c \in C$, the following diagram commutes:

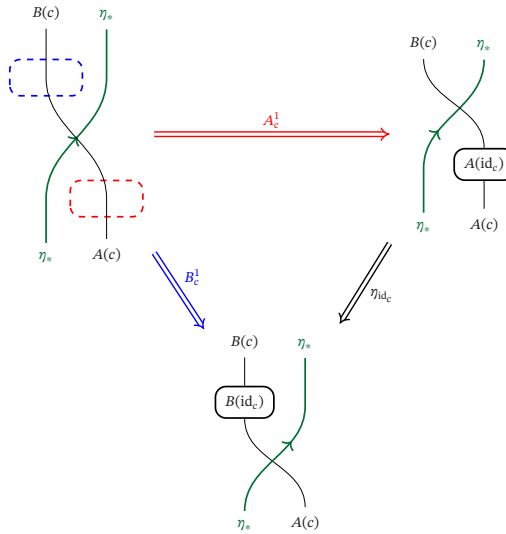

Observe this immediately implies that $\eta_{\text{id}_c} = B_c^1 * (A_c^1)^{-1}$ for all $c \in C$.

(T-III) A unit coherence invertible 2-modification

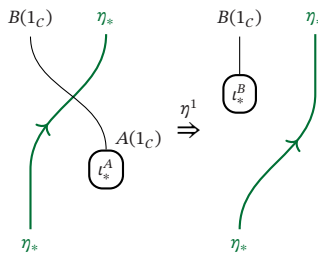

The 2-modification criterion for η^1 is automatically satisfied by (F-III) (which says $\iota_1^A = A_{1c}^1$ and $\iota_1^B = B_{1c}^1$) and (T-II).iii above.

(T-IV) For every $a, b \in C$, a monoidality coherence invertible 2-modification

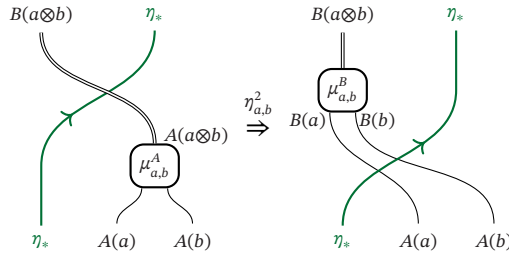

That η^2 is a 2-modification means that for all $x \in C(a_1 \rightarrow a_2)$ and $y \in C(b_1 \rightarrow b_2)$,

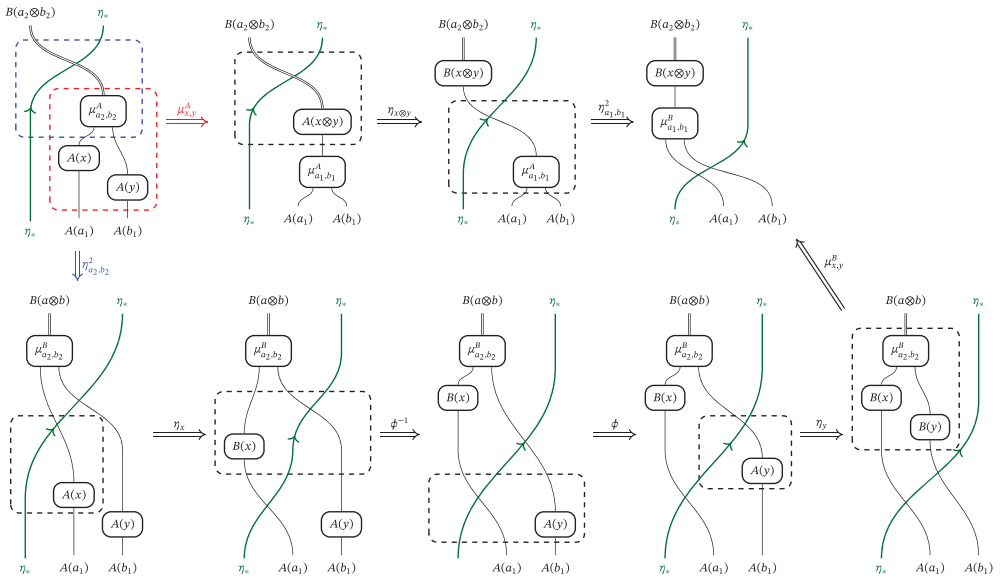

These data are subject to the following additional three coherences, cf. [35, Definition 4.16].

(T-1) For all $a, b, c \in \mathcal{C}$, the following diagram commutes:

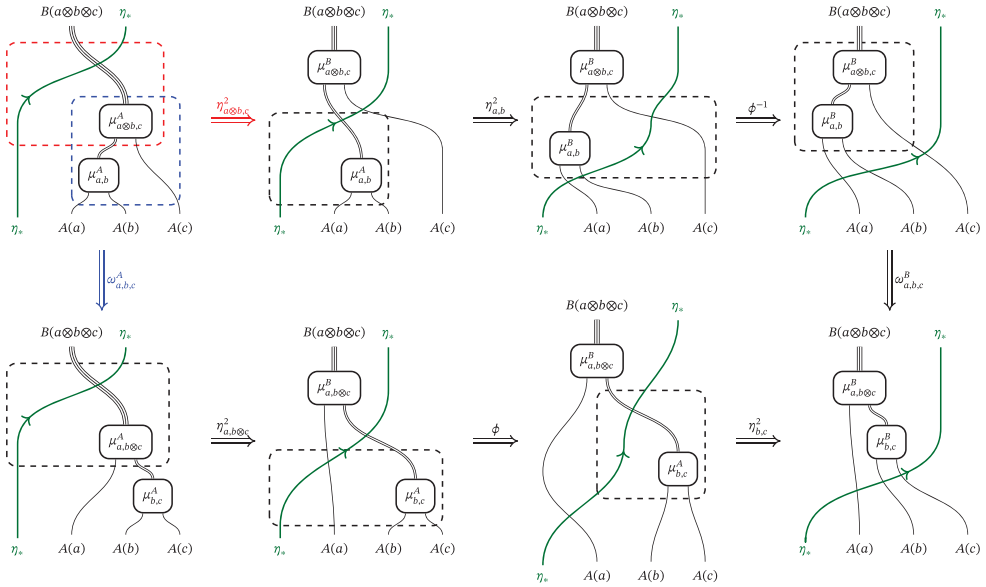

(T-2) For all $c \in \mathcal{C}$, the following diagram commutes:

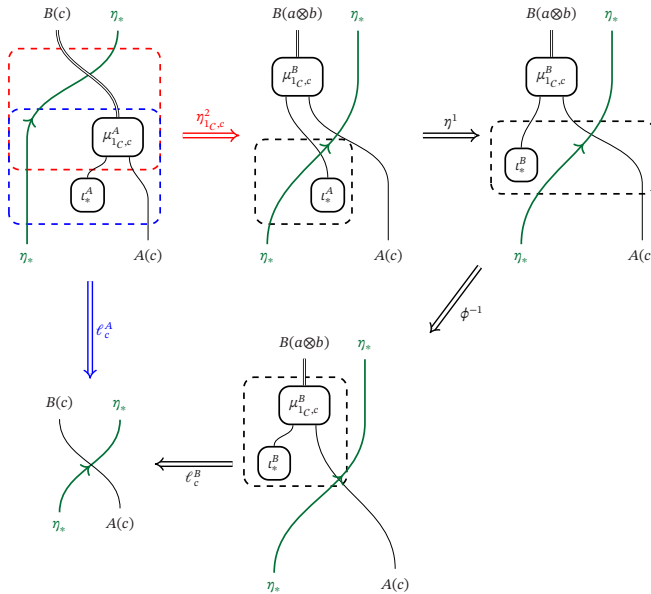

and a similar coherence equation holds for r_c^A as well.

Observe that (T-2) completely determines η^1 in terms of lower data. This means that one needs only to verify the existence of some η^1 satisfying (T-2) to verify (T-III) above.

A.3 | Modifications between transformations of Gray-monoids

Definition A.3. Suppose \mathcal{C}, \mathcal{D} are Gray-monoids, $A, B : \mathcal{BC} \rightarrow \mathcal{BD}$ are 3-functors, and $\eta, \zeta : A \Rightarrow B$ are transformations. A modification $m : \eta \Rrightarrow \zeta$ consists of:

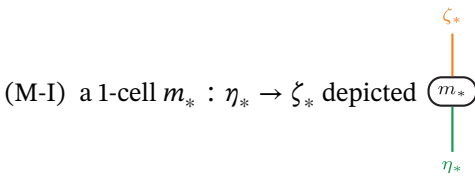

(M-II) For each $c \in C$, an invertible 2-modification

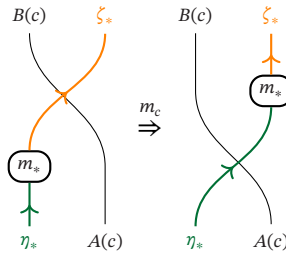

Explicitly, this means that m_c satisfies the following coherence condition for all $x : a \rightarrow b$:

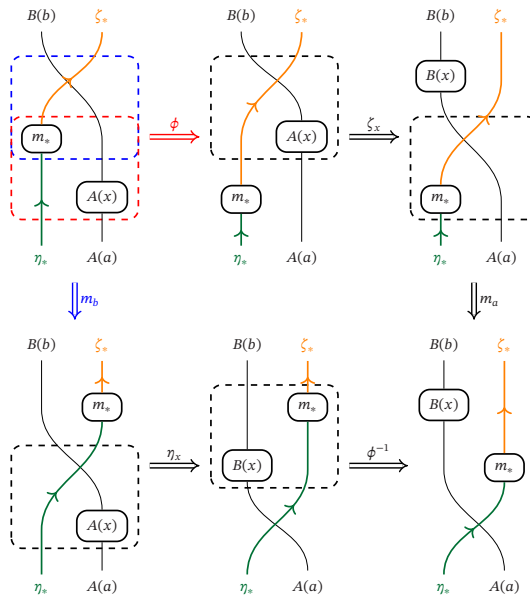

These data are subject to the following two conditions, cf. [35, Definition 4.18]:

(M-1) For all $a, b \in \mathcal{C}$,

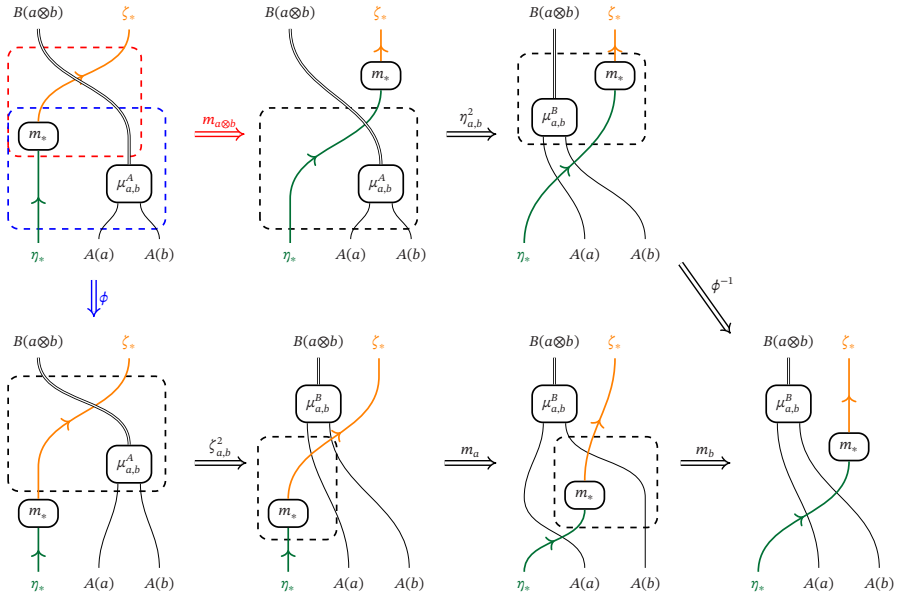

(M-2) The following diagram commutes:

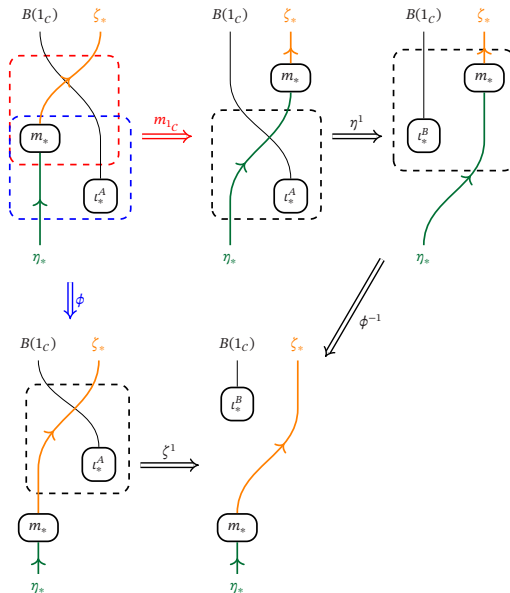

Observe this coherence completely determines m_{1_C} in terms of η^1 and ζ^1 .

A.4 | Perturbations between modifications of Gray-monoids

Definition A.4. Suppose \mathcal{C}, \mathcal{D} are Gray-monoids, $A, B : \mathcal{BC} \rightarrow \mathcal{BD}$ are 3-functors, $\eta, \zeta : A \Rightarrow B$ are transformations, and $m, n : \eta \Rrightarrow \zeta$ are modifications. A perturbation $\rho : m \Rrightarrow n$ consists of a 2-cell $\rho_* : m_* \Rightarrow n_*$ satisfying the following coherence condition, cf. [35, Definition 4.21].

(P-1) For each $c \in C$, the following square commutes:

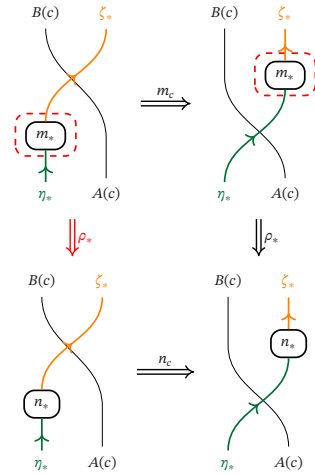

APPENDIX B: COHERENCE PROOFS FOR STRICTIFICATION

This appendix contains all proofs from Section 3 which amount to checking/using various coherence conditions from Appendix A. As most of the proofs in this section are similar, we provide full detail for one part of each coherence proof below, and we explain the components of the proof in other parts whose details are left to the reader. To make the commutative diagrams more readable, we suppress all whiskering notation, including Notation 2.7.

B.1 | Coherence proofs for Strictifying 1-morphisms Subsection 3.2

We remind the reader that $(BC, \pi^C), (BD, \pi^D)$ are two objects in $3Cat_G^{Dl}$, so that C, D are Gray-monoids, and $(A, \alpha) \in 3Cat_G((BC, \pi^C) \rightarrow (BD, \pi^D))$. We specified data for $(B, \beta) : (BC, \pi^C) \rightarrow (BD, \pi^D)$ above in Subsection 3.2, together with data for $(\gamma, id) : (B, \beta) \Rightarrow (A, \alpha)$.

Notation B.1. In this section, we will use a shorthand notation for 1-cells in D for proofs using commutative diagrams. For $x \in C(a \rightarrow b), y \in C(b \rightarrow c)$, and $z \in C(c \rightarrow d)$, we will denote their corresponding image in D under A as a small shaded square, for example,

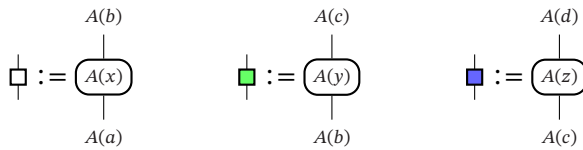

While the 1-composition \circ in D is stacking of diagrams, we denote A applied to a 1-composite in C by vertically joining the shaded squares:

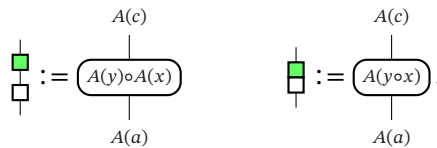

Since 1-composition in \mathcal{C} and \mathcal{D} are both strict, we denote a triple 1-composite by stacking three boxes, and we denote A applied to a triple 1-composite by vertically joining three boxes:

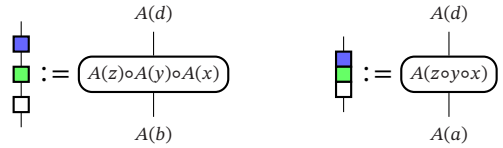

For the \otimes composite of 1-cells, we use the nudging convention as in (8). We denote A applied to a \otimes composite of 1-cells in \mathcal{C} by joining the shaded boxes along corners. For the following example, given $x_1 \in \mathcal{C}(a_1 \rightarrow b_1)$, $y_1 \in \mathcal{C}(b_1 \rightarrow c_1)$, $x_2 \in \mathcal{C}(a_2 \rightarrow b_2)$, and $y_2 \in \mathcal{C}(b_2 \rightarrow c_2)$, we write

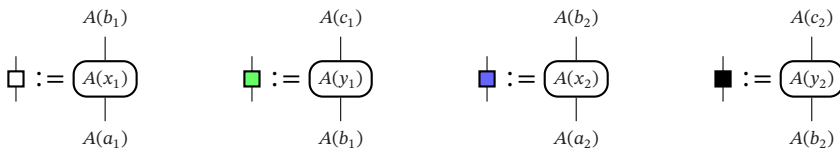

We then write

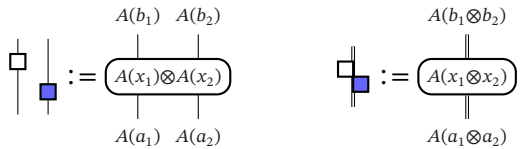

In this notation, we would write the following diagram for A applied to the following composites:

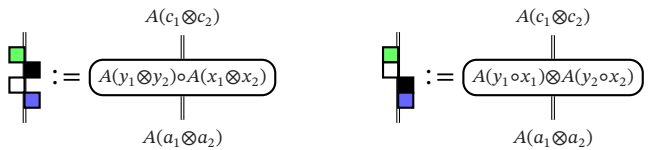

Proof of Lemma 3.10: (B, B^1, B^2) is a 2-functor. We must check (F-I) for B . We provide a complete proof for (F-I).i, and leave most of (F-I).ii as an exercise for the reader.

(F-I).i For $x \in \mathcal{C}(g_c \rightarrow h_c)$, $y \in \mathcal{C}(h_c \rightarrow k_c)$, and $z \in \mathcal{C}(k_c \rightarrow \ell_c)$, we use the following shorthand as in Notation B.1:

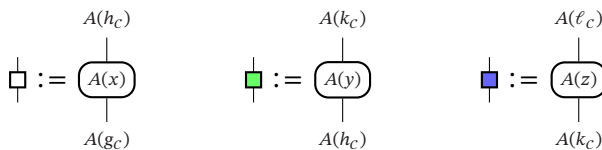

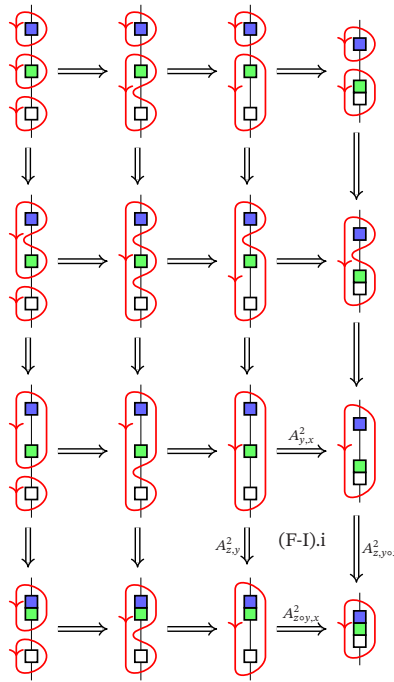

Every square except for the bottom right square commutes by functoriality of 1-cell composition \circ in a Gray-monoid, that is, applying two 2-cells locally to non-overlapping regions in a 1-cell commutes. The bottom right square commutes by (F-I).i applied to the underlying 2-functor of A .

(F-I).ii Follows from the properties of the adjoint equivalence α (see Remark B.2) together with (F-I).ii for the underlying 2-functor of A . □

Remark B.2. In subsequent proofs, we will freely combine squares that commute by functoriality of 1-cell composition \circ when the involved 2-cells applied locally are part of the biadjoint biequivalence α_* (BB) or the adjoint equivalences α_g . We will then simply state this larger face commutes by the properties of the adjoint equivalence α , that is, the properties of the biadjoint biequivalence α_* (BB) and the properties of the adjoint equivalences α_g .

Proof of Lemma 3.12: $(B, \mu^B, \iota^B, \omega, \ell, r)$ is a weak 3-functor $BC \rightarrow BD$.

(F-II).i Every component which makes up μ^B , in Construction 3.11, especially μ^A , is natural.

(F-II).ii For $x_1 \in C(a_1 \rightarrow b_1)$, $y_1 \in C(b_1 \rightarrow c_1)$, $x_2 \in C(a_2 \rightarrow b_2)$, and $y_2 \in C(b_2 \rightarrow c_2)$, we use the following shorthand as in Notation B.1:

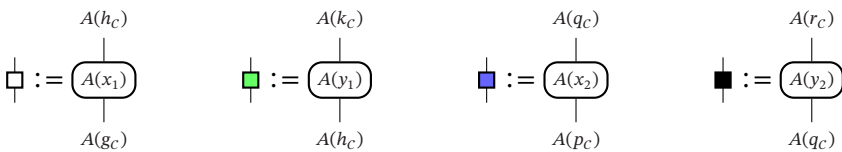

For the following diagram to fit on one page, we compress the definition of $\mu_{x,y}^B$ from Construction 3.11 into four steps

$$\mu_{x,y}^B := \left(\begin{array}{c} \text{Diagram 1} \Rightarrow \text{Diagram 2} \xRightarrow{(\alpha_{h,q}^2)^{-1}} \text{Diagram 3} \xRightarrow{\mu^A} \text{Diagram 4} \xRightarrow{(\alpha_{g,p}^2)^{-1}} \text{Diagram 5} \end{array} \right), \quad (B.1)$$

we suppress as many interchangers as possible, and we combine commuting squares involving only α_* and the α_g as in Remark B.2.

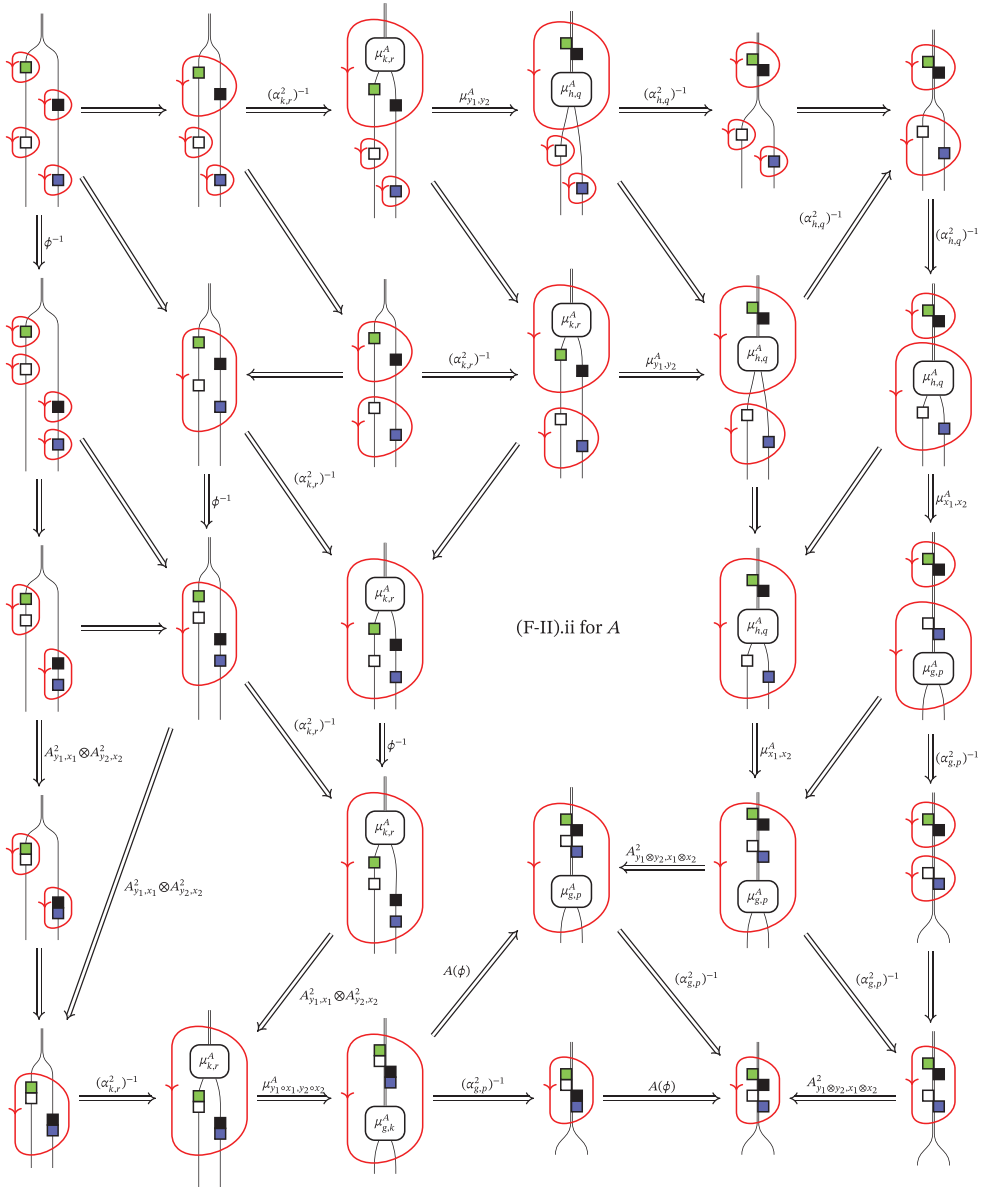

Non-labeled faces either commute by functoriality of 1-cell composition \circ , axioms (C4) and (C5) of the interchanger, or Remark B.2.

- (F-II).iii This follows by Remark B.2 and functoriality of 1-cell composition \circ , together with (F-II).iii applied to A .
- (F-III) This part is automatic as $\iota_1^B := B_e^1$.
- (F-IV) This follows by Remark B.2 and functoriality of 1-cell composition \circ , together with (F-IV) applied to A and two instances of (T-1) for the transformation $\alpha : \pi^D \Rightarrow A \circ \pi^C$.
- (F-V) This follows by Remark B.2 and functoriality of 1-cell composition \circ , together with (F-V) applied to A and two instances of (T-2) for the transformation $\alpha : \pi^D \Rightarrow A \circ \pi^C$.
- (F-1) Every map is the identity map.
- (F-2) Every map is the identity map. □

Proof of Lemma 3.13: $(\beta_*, \beta_g, \beta_{id_g}, \beta^1, \beta^2)$ is a 2-natural transformation $\pi^D \Rightarrow B \circ \pi^C$.

- (T-II).i This condition is immediate as the only 1-cells and 2-cells in BG are identities.
- (T-II).ii This step amounts to checking $B_{id_g, id_g}^2 * (B_g^1 \circ B_g^1) = B_g^1$. Using Remark B.2 and functoriality of 1-cell composition \circ , this reduces to the identity $A_{id_g, id_g}^2 * (A_g^1 \circ A_g^1) = A_g^1$.
- (T-II).iii This condition is immediate as $(\pi^D)_g^1 = id_{id_{gD}}$ and $\beta_g^1 = B_g^1$.
- (T-III) This condition is automatically satisfied.
- (T-IV) This condition is immediate as $\mu_{g,h}^{\pi^D} = id_{gh_D} = \mu_{g,h}^{B \circ \pi^C}$ and $\beta_g = id_g$ for all $g \in G$.
- (T-1) Every map is the identity map.
- (T-2) Every map is the identity map. □

Proof of Theorem 3.14: $(\gamma, id) : (B, \beta) \Rightarrow (A, \alpha)$ is an invertible 2-morphism in $3Cat_C$. It suffices to prove that γ defines a 2-transformation $\gamma : B \Rightarrow A$, as it clearly invertible.

- (T-II).i Every component which makes up γ_x in (14) is natural in x .
- (T-II).ii This follows by Remark B.2.
- (T-II).iii This follows by Remark B.2.
- (T-III) This condition is automatically satisfied.
- (T-IV) For $x \in C(g_C \rightarrow h_C)$ and $y \in C(k_C \rightarrow \ell_C)$, we use the following shorthand as in Notation B.1:

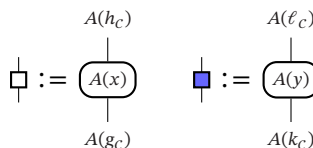

For the following diagram to fit on one page, we compress the definition of $\mu_{x,y}^B$ from Construction 3.11 into four steps as in (B.1), we suppress as many interchangers as possible, and we combine commuting squares involving only α_* and the α_g as in Remark B.2.

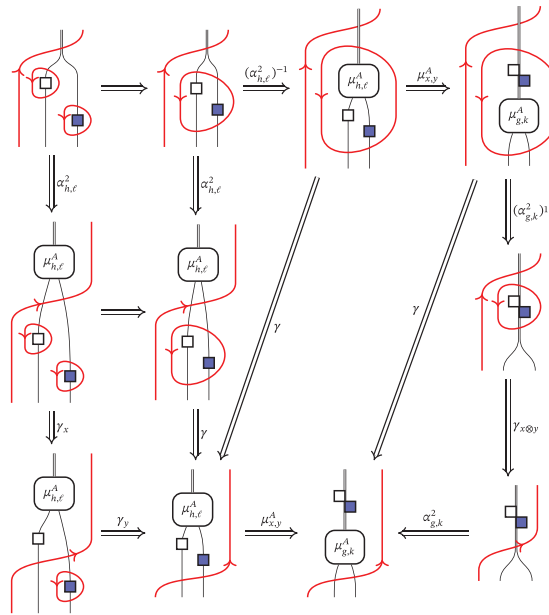

Every square here commutes by properties of the biadjoint biequivalence α_* (BB), the adjoint equivalences α_g , and functoriality of 1-cell composition \circ .

- (T-1) Since $\omega_{g,h,k}^B$ is the identity, it is equal to $\omega_{g,h,k}^{\pi^D}$. Since (T-1) holds for $\alpha : \pi^D \Rightarrow A \circ \pi^C$, we conclude (T-1) holds for $\zeta : B \Rightarrow A$.
- (T-2) Since ℓ_g^B, r_g^B are identities, they are equal to $\ell_g^{\pi^D}, r_g^{\pi^D}$, respectively. Since (T-2) holds for $\alpha : \pi^D \Rightarrow A \circ \pi^C$, we conclude (T-2) holds for $\zeta : B \Rightarrow A$. □

B.2 | Coherence proofs for Strictifying 2-morphisms Subsection 3.3

We remind the reader that $(BC, \pi^C), (BD, \pi^D) \in 3\text{Cat}_G^{Dt}$, $(A, \alpha), (B, \beta) \in 3\text{Cat}_G^{Dt}((BC, \pi^C) \rightarrow (BD, \pi^D))$, and $(\eta, m) \in 3\text{Cat}_G((A, \alpha) \Rightarrow (B, \beta))$. We specified data for $(\zeta, \text{id}) : (A, \alpha) \Rightarrow (B, \beta)$ above in Subsection 3.3.

Proof of Lemma 3.16: $(\zeta, \text{id}) : (A, \alpha) \Rightarrow (B, \beta)$ is a 2-morphism in 3Cat_G . It suffices to check that $\zeta : A \Rightarrow B$ is a 2-natural transformation.

- (T-II).i Every component which makes up ζ_x in (16) is natural in x .
- (T-II).ii This follows by Remark B.2 and functoriality of 1-cell composition \circ , together with (T-II).ii applied to $\alpha : \pi^D \Rightarrow A \circ \pi^C$.
- (T-II).iii This follows by Remark B.2 and functoriality of 1-cell composition \circ , together with (T-II).iii applied to $\alpha : \pi^D \Rightarrow A \circ \pi^C$.
- (T-III) This condition is automatically satisfied.
- (T-IV) For $x \in C(g_C \rightarrow h_C)$ and $y \in C(k_C \rightarrow \ell_C)$, we use the following shorthand as in Notation B.1:

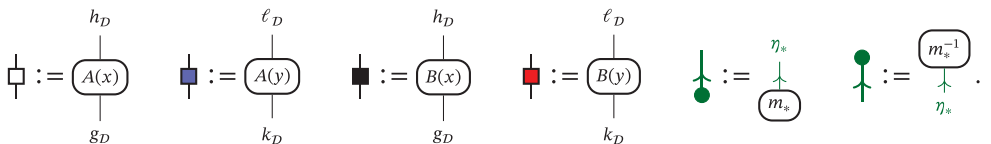

For the following diagram to fit on one page, we compress the definition of ζ_x from (16) into three steps

$$\zeta_x := \left(\begin{array}{c} \left| \begin{array}{c} \square \\ \square \end{array} \right\rangle \Rightarrow \left| \begin{array}{c} \bullet \\ \square \\ \bullet \end{array} \right\rangle \xrightarrow{\eta_x} \left| \begin{array}{c} \bullet \\ \bullet \\ \square \end{array} \right\rangle \Rightarrow \left| \begin{array}{c} \bullet \\ \bullet \\ \bullet \end{array} \right\rangle \end{array} \right),$$

and we combine and suppress as many interchangers as possible, simply writing ϕ .

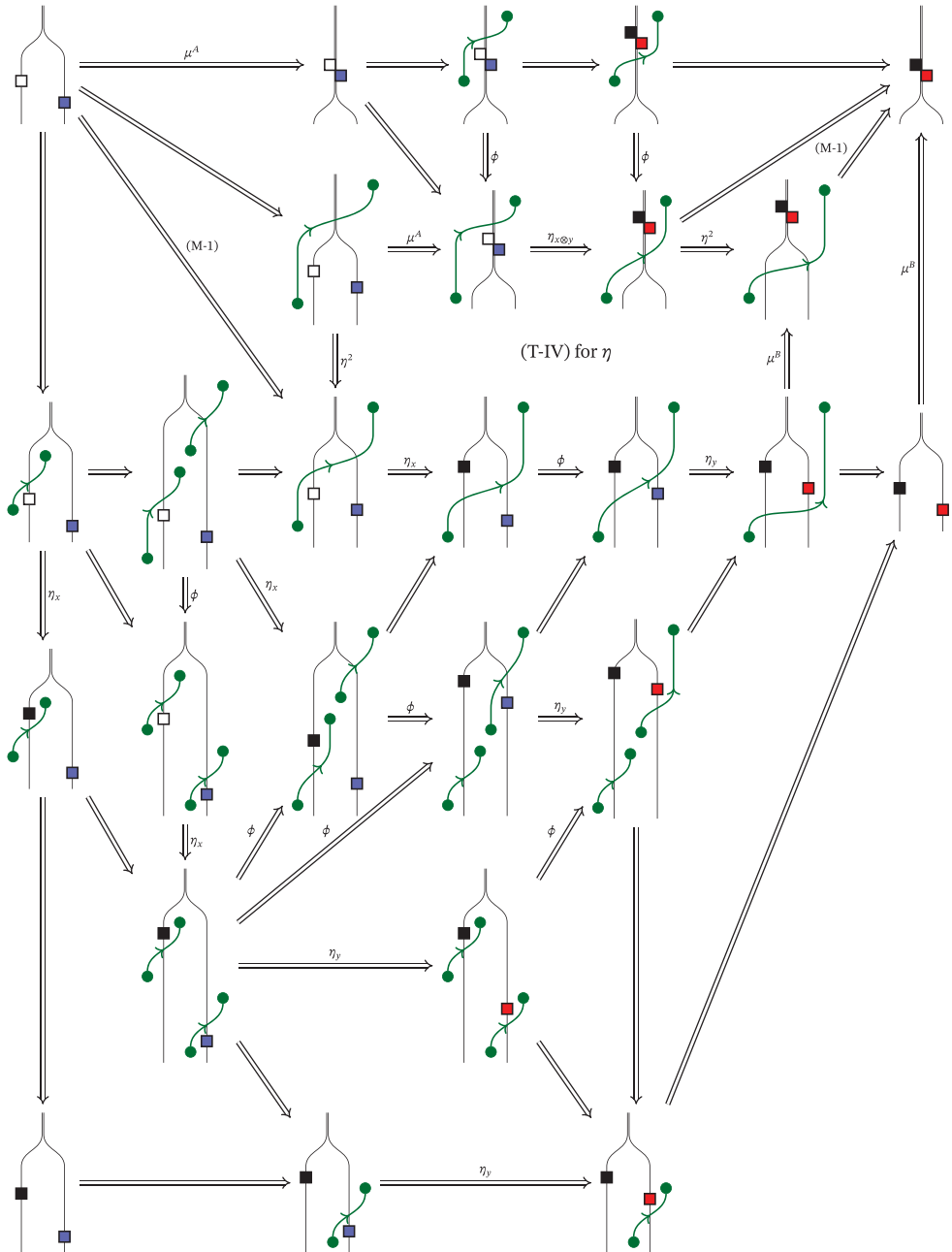

Non-labeled faces commute by either functoriality of 1-cell composition \circ or by properties of a (bi)adjoint (bi)equivalence.

- (T-1) Every map is the identity map.
- (T-2) Every map is the identity map. □

We remind the reader that by the strictness properties for α, β as components of 1-morphisms in 3Cat_G^{pt} , $m_* : e_D \Rightarrow \eta_*$, and m_g is an invertible 2-cell

$$\begin{array}{c} \textcircled{m_*} \\ \hline g_D \end{array} \Bigg| \xRightarrow{m_g} \Bigg| \begin{array}{c} \textcircled{m_*} \\ \hline g_D \end{array}. \tag{B.2}$$

Proof of Theorem 3.17: $(m, \text{id}) : (\zeta, \text{id}) \Rrightarrow (\eta, m)$ is an invertible 3-morphism in 3Cat_G . It suffices to check that $m : \zeta \Rrightarrow \eta$ is an invertible 3-modification.

- (M-II) This condition corresponds for $m : \zeta \Rrightarrow \eta$ corresponds to the outside of the following commutative diagram, where we use the following shorthand notation for $x \in \mathcal{C}(g_C \rightarrow h_C)$ and m_*, m_*^{-1} :

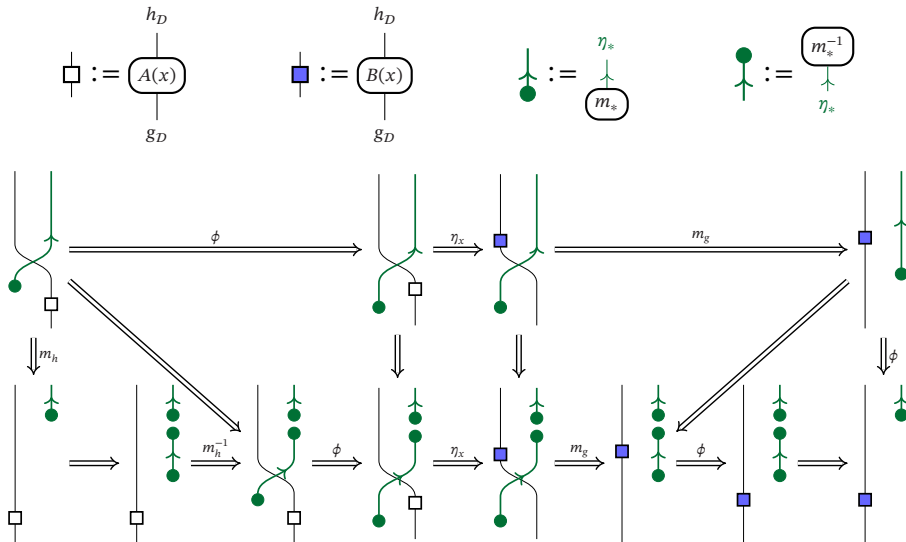

All inner faces in the above diagram are squares which commute by functoriality of 1-cell composition \circ .

- (M-1) This is exactly (M-1) applied to m viewed as a modification $m : \beta \Rrightarrow (\eta \circ \text{id}_{\pi_C}) * \alpha$ as in (9) above
- (M-2) By the strictness properties of (A, α) and (B, β) , (M-2) for the modification $m : \beta \Rrightarrow (\eta \circ \text{id}_{\pi_C}) * \alpha$ as in (9) above tells us that $m_{1_C} = \eta^1$ on the nose. This exactly gives the coherence (M-2) for γ . □

B.3 | Coherence proofs for Strictifying 3-morphisms Subsection 3.4

We remind the reader that in this section, $(\eta, m = \text{id}), (\zeta, n = \text{id}) : (A, \alpha) \Rrightarrow (B, \beta)$ are two 2-morphisms in 3Cat_G^{pt} and $(p, \rho) : (\eta, \text{id}) \Rrightarrow (\zeta, \text{id})$ is a 3-morphism in 3Cat_G . This means ρ_* is an invertible 2-cell $\text{id}_{\text{id}_{e_D}} \Rrightarrow p_*$ satisfying the coherence

$$\left(\begin{array}{c} \text{---} \\ \rho_* \\ \text{---} \\ g_D \end{array} \Big| \begin{array}{c} \rho_* \\ \text{---} \\ P_* \\ g_D \end{array} \Big| \begin{array}{c} P_g \\ \text{---} \\ P_* \\ g_D \end{array} \Rightarrow \begin{array}{c} \text{---} \\ \rho_* \\ \text{---} \\ g_D \end{array} \Big| \begin{array}{c} P_* \\ \text{---} \\ P_* \\ g_D \end{array} \right) = \left(\begin{array}{c} \text{---} \\ \rho_* \\ \text{---} \\ g_D \end{array} \Big| \begin{array}{c} \rho_* \\ \text{---} \\ P_* \\ g_D \end{array} \right) \quad \forall g \in G. \tag{B.3}$$

Proof of Lemma 3.18: $\eta_x = \zeta_x$ for all $x \in C(g_C \rightarrow h_C)$. For $x \in C(g_C \rightarrow h_C)$, we use the following shorthand as in Notation B.1.

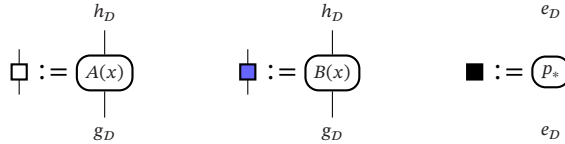

The outside of the following commutative diagram is a bigon with one arrow η_x and one arrow ζ_x ; hence $\eta_x = \zeta_x$:

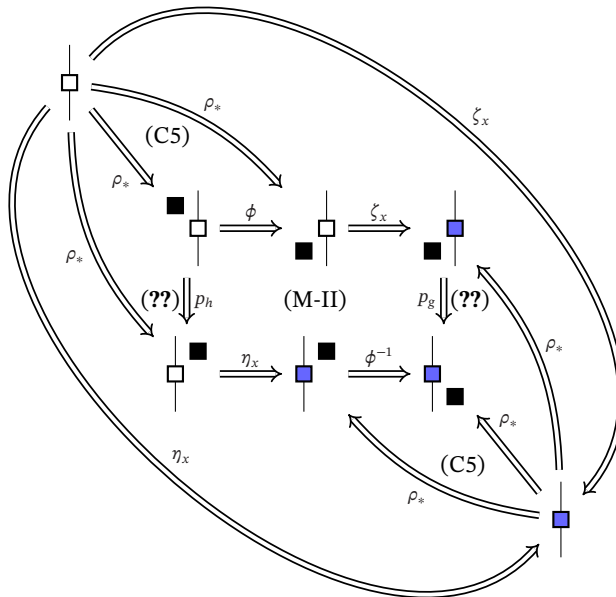

The unlabeled faces commute by functoriality of 1-cell composition \circ . □

APPENDIX C: COHERENCE PROOFS FOR G -CROSSED BRAIDED CATEGORIES

This appendix contains all proofs from Section 4 which amount to checking/using various coherence conditions using the properties listed in Appendix A. To make the commutative diagrams more readable, we suppress all whiskering notation, including Notation 2.7.

C.1 | Coherence proofs for the 2-functor $3\text{Cat}_G^{\text{st}}$ to $G\text{CrSBrd}^{\text{st}}$ from Subsection 4.2

We now supply the proofs for statements in Subsection 4.2. We remind the reader that $(\mathcal{C}, \otimes_{g,h}, F_g, \beta_{g,h})$ is the data constructed from $C \in 3\text{Cat}_G^{\text{st}}$ in Constructions 4.8, 4.9, and 4.10.

Proof of Theorem 4.11: $(\mathcal{C}, \otimes_{g,h}, F_g, \beta_{g,h})$ forms a strict G -crossed braided category. We remind the reader that we use the shorthand notation that white, green, and blue shaded disks correspond

to 1-morphisms into $g_C, h_C,$ and $k_C,$ respectively:



It remains to check the commutativity of $(\beta_1), (\beta_2),$ and $(\beta_3).$ We treat (β_1) in detail. Going around the outside of the diagram below corresponds to $(\beta_1).$ The large face consists of only equalities, so it manifestly commutes.

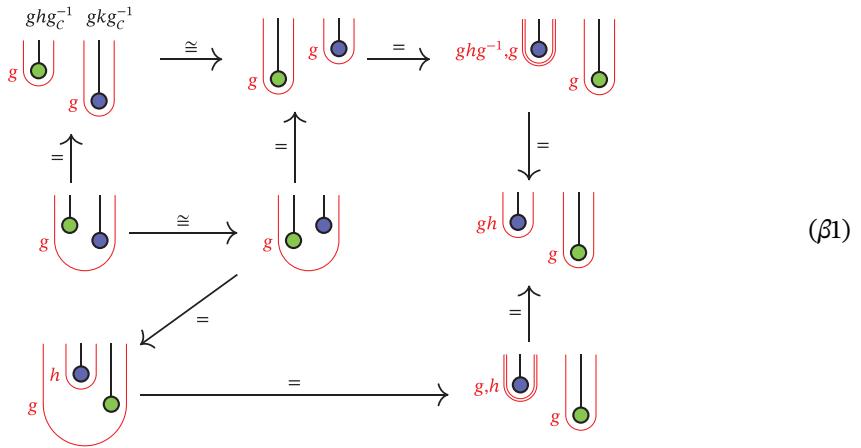

The top left square commutes as the only two non-trivial maps are the same interchanger.

The equations (β_2) and (β_3) are similar. In the two diagrams below, the outside 7 diagrams are the vertices in the heptagons (β_2) and $(\beta_3),$ respectively. There is only one non-trivial face in each the two diagrams below corresponding to these two coherences, and this face commutes by the axiom (C4) of the interchanger in a Gray-monoid.

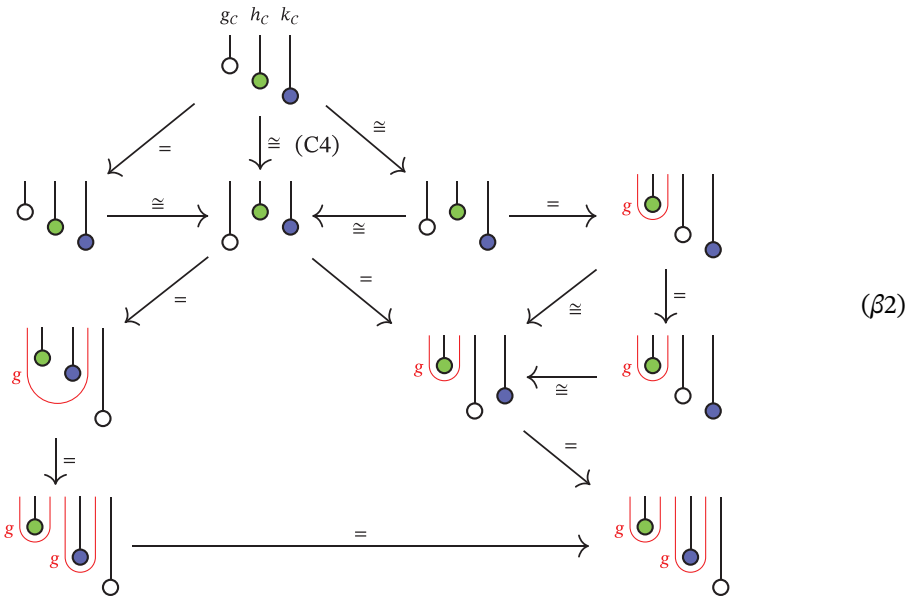

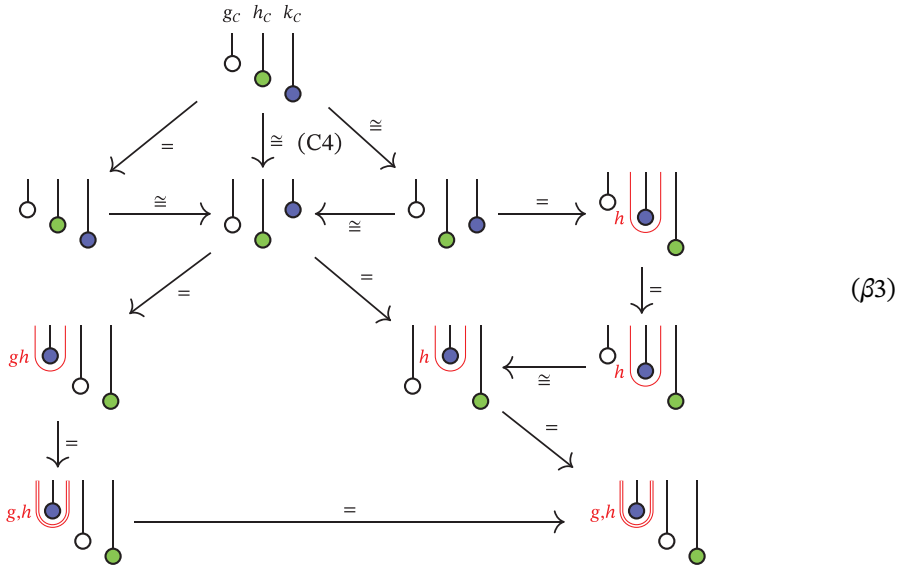

This completes the proof. □

For $C, D \in 3\text{Cat}_G^{\text{st}}$, $A, B \in 3\text{Cat}_G^{\text{st}}(C \rightarrow D)$, and $\eta \in 3\text{Cat}_G^{\text{st}}(A \Rightarrow B)$, let $\mathfrak{C}, \mathfrak{D}$ be the G -crossed braided categories obtained from C, D , respectively, from Theorem 4.11. In Construction 4.12 and (19), we defined the data $(\mathbf{A}, \mathbf{a}) : \mathfrak{C} \rightarrow \mathfrak{D}$.

Proof of Lemma 4.13: $(\mathbf{A}, \mathbf{A}^1, \mathbf{A}^2) : \mathfrak{C} \rightarrow \mathfrak{D}$ is a G -graded monoidal functor. That each \mathbf{A}_g is a functor follows immediately from the fact that A is a functor. The data \mathbf{A}^2 satisfy associativity by property (F-IV) of (A, μ^A, ι^A) , and the data \mathbf{A}^2 and \mathbf{A}^1 satisfy unitality by property (F-V) of (A, μ^A, ι^A) . (Observe that in (F-IV) and (F-V), all instances of ϕ, ω^A, ℓ^A , and r^A are identities, so these reduce to the usual associativity and unitality conditions for a monoidal functor.) □

Proof of Theorem 4.14: $(\mathbf{A}, \mathbf{A}^1, \mathbf{A}^2, \mathbf{a}) : \mathfrak{C} \rightarrow \mathfrak{D}$ is a G -crossed braided monoidal functor. Naturality of \mathbf{a} follows by naturality of \mathbf{A}^1 and (F-II).i of μ^A . It remains to prove the coherences $(\gamma 1)$ and $(\gamma 2)$.

$(\gamma 1)$ Observe that since \mathfrak{C} and \mathfrak{D} are strict, the coherence condition $(\gamma 1)$ is actually a triangle. For $a \in \mathfrak{C}_k$, we use the shorthand notation a small shaded box for $A(a)$. For $g, h \in G$ and $a \in \mathfrak{C}_k = C(1_C \rightarrow k_C)$, we use the following shorthand as in Notation B.1:

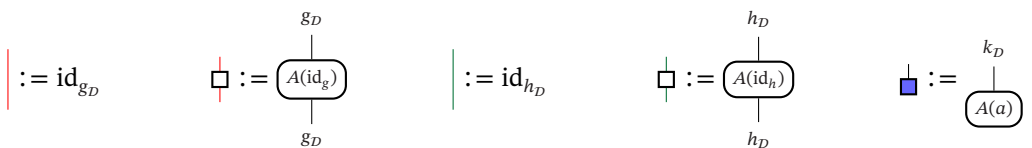

Observe that since C is Gray, we have an equality $\text{id}_{g_C} \otimes \text{id}_{h_C} = \text{id}_{gh_C}$:

$$\begin{array}{c} gh_D \\ \square = \square = A(\text{id}_{gh_C}) \\ gh_D \end{array}$$

Expanding (19), we see that $(\gamma 1)$ follows from the following commuting diagram. (Recall that the cups on the bottom in (19) are really identity maps, and do not need to be drawn.)

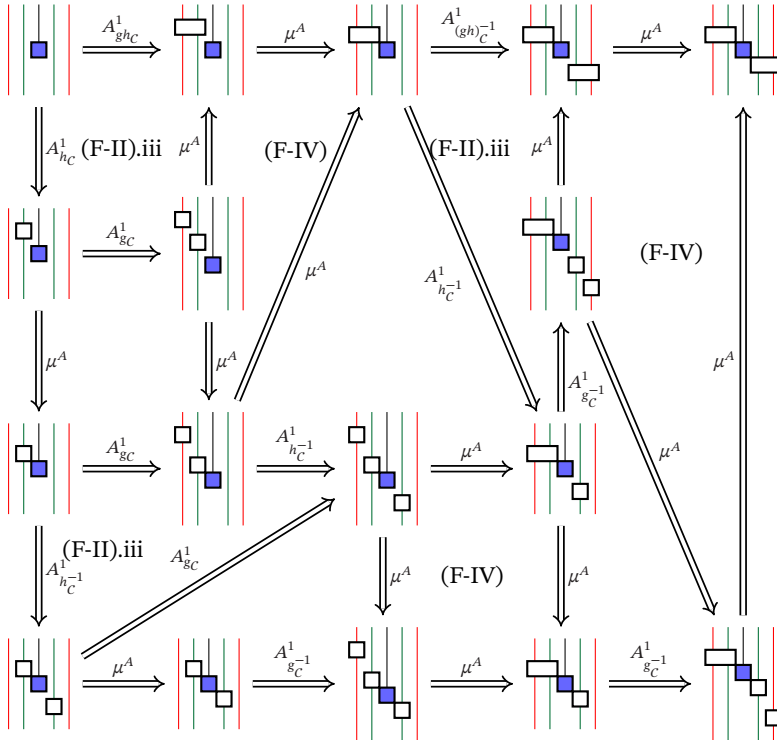

Each square above is labeled by the property for A which makes it commute. Unlabeled squares commute by functoriality of 1-cell composition \circ .

($\gamma 2$) For $g, h \in G$, $a \in \mathfrak{G}_g = \mathcal{C}(1_C \rightarrow g_C)$, and $b \in \mathfrak{G}_h = \mathcal{C}(1_C \rightarrow h_C)$, we use the following shorthand as in Notation B.1:

$$\begin{array}{ccccc} e_D & & g_D & & g_D \\ \square := A(\text{id}_e) & \square := A(\text{id}_g) & \square := A(a) & \square := A(b) & \square := A(F_g^e(b)) \\ e_D & & g_D & & h_D \end{array}$$

Recall that by Construction 4.10 of the G -crossed braiding in \mathfrak{C} , we have the identities

$$\begin{array}{c} \square = \square \\ \square = \square \end{array}$$

Going around the outside of the diagram below corresponds to $(\gamma 2)$.

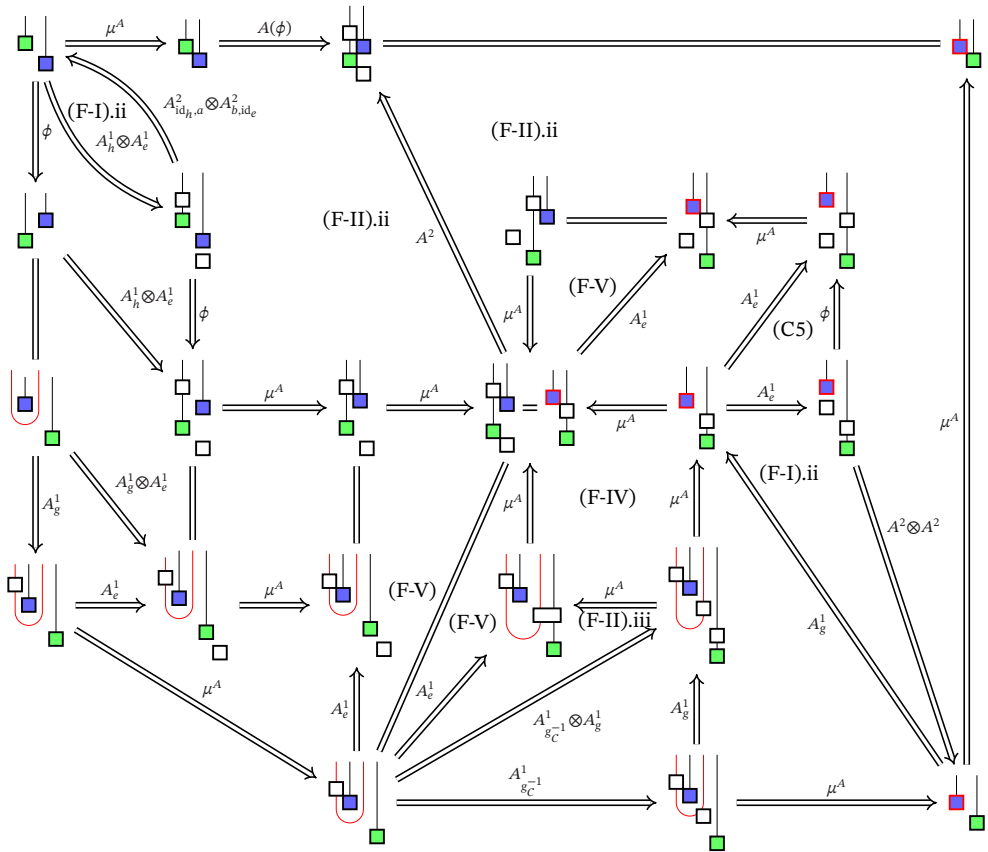

Again, each square above is labeled by the property for A which makes it commute. □

Remark C.1. By an argument similar to the right half of the commutative diagram in the proof of (γ_2) above, for a functor $A \in 3\text{Cat}_G^{\text{st}}$, $x \in C(1_C \rightarrow g_C)$, and $y \in C(h)C \rightarrow k_C$, the following square commutes:

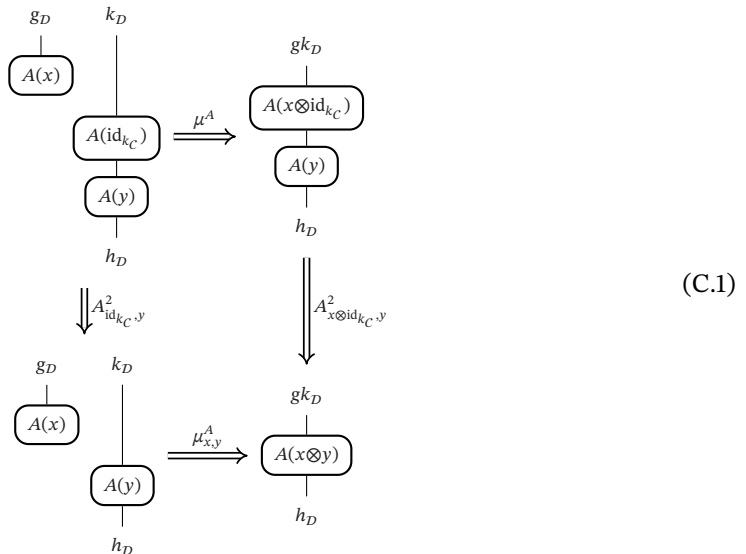

Proof of Proposition 4.15: $(A, \mu^A, \iota^A) \mapsto (\mathbf{A}, \mathbf{a})$ is strict. It is straightforward to see that if $(A, A^1, A^2, \mu^A, \iota^A) \in 3\text{Cat}_G^{\text{st}}(\mathcal{C} \rightarrow \mathcal{C})$ is the identity 3-functor, then so is $(\mathbf{A}, \mathbf{A}^1, \mathbf{A}^2, \mathbf{a}) \in G\text{CrBrd}^{\text{st}}(\mathfrak{C} \rightarrow \mathfrak{C})$. Suppose now we have two composable 1-morphisms $(A, A^1, A^2, \mu^A, \iota^A) \in 3\text{Cat}_G^{\text{st}}(\mathcal{D} \rightarrow \mathcal{E})$ and $(B, B^1, B^2, \mu^B, \iota^B) \in 3\text{Cat}_G^{\text{st}}(\mathcal{C} \rightarrow \mathcal{D})$. We now calculate the composition formulae for the composite G -crossed braided monoidal functor $(\mathbf{A} \circ \mathbf{B}, (\mathbf{A} \circ \mathbf{B})^1, (\mathbf{A} \circ \mathbf{B})^2, \mathbf{a} \circ \mathbf{b})$ associated to $(A \circ B, (A \circ B)^2, (A \circ B)^1, \mu^{A \circ B}, \iota^{A \circ B})$. The unitor $(\mathbf{A} \circ \mathbf{B})^1$ and tensorator $(\mathbf{A} \circ \mathbf{B})^2$ are straightforward:

$$(\mathbf{A} \circ \mathbf{B})^1 = (A \circ B)_e^1 = A(B_e^1) * A_e^1 = \mathbf{A}(B^1) * \mathbf{B}_e^1$$

$$(\mathbf{A} \circ \mathbf{B})_{x,y}^2 = \mu_{x,y}^{A \circ B} = A(\mu_{x,y}^B) * \mu_{B(x),B(y)}^A = \mathbf{A}(B_{x,y}^2) * \mathbf{A}_{B(x),B(y)}^2.$$

To compute $(\mathbf{a} \circ \mathbf{b})_x$ for $x \in \mathcal{C}(1_{\mathcal{C}} \rightarrow g_{\mathcal{C}})$, we use the following shorthand as in Notation B.1, where black rectangles and strings corresponds to 1-cells in \mathcal{E} after applying A , and blue rectangles and strands corresponds to 1-cells in \mathcal{D} after applying B . We also draw red strands to denote id_g in both \mathcal{D} and \mathcal{E} . For example,

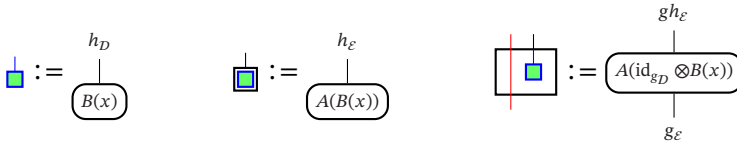

We draw unshaded boxes on red strands to denote $B(\text{id}_{g_{\mathcal{D}}}), B(\text{id}_{g_{\mathcal{D}}})^{-1}, A(\text{id}_{g_{\mathcal{D}}}), A(\text{id}_{g_{\mathcal{D}}})^{-1}$.

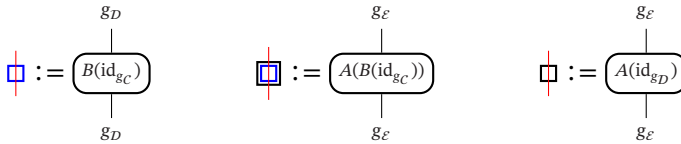

The composite along the diagonal in the commuting diagram below is the definition of $(\mathbf{a} \circ \mathbf{b})_x$. Each face without a label above commutes by functoriality of 1-cell composition \circ .

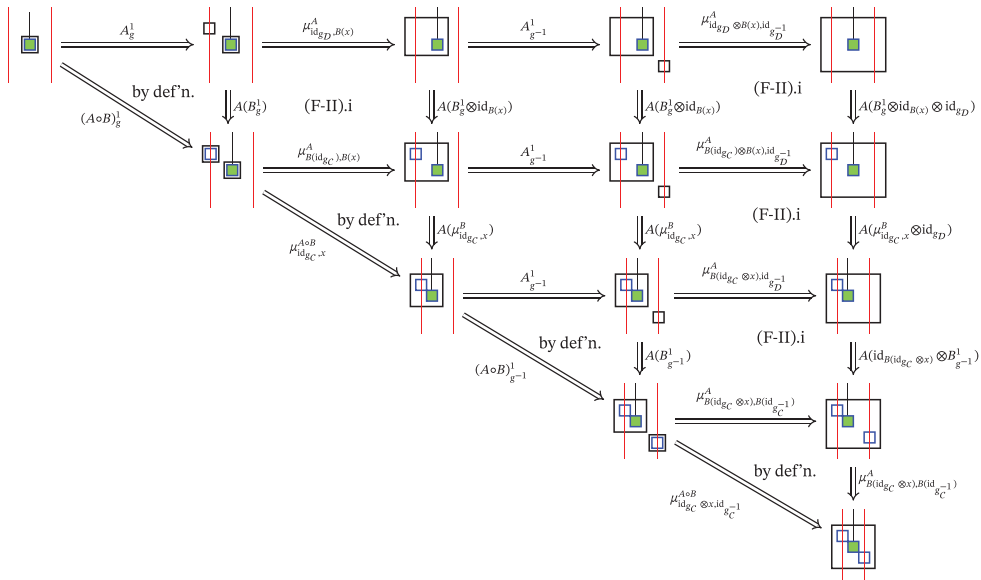

As the above diagram commutes, $(\mathbf{a} \circ \mathbf{b})_x = \mathbf{A}(\mathbf{a}_{F^D(B(x))}) * \mathbf{a}_{\mathbf{B}(x)}$.

Finally, we observe these data agree with the data for the composite of the G -crossed braided monoidal functors $(\mathbf{A}, \mathbf{A}^1, \mathbf{A}^2, \mathbf{a})$ and $(\mathbf{B}, \mathbf{B}^1, \mathbf{B}^2, \mathbf{b})$ in $GCrsBrd$. \square

For $C, D \in 3Cat_G^{st}$, $A, B \in 3Cat_G^{st}(C \rightarrow D)$, and $\eta \in 3Cat_G^{st}(A \Rightarrow B)$, let $\mathfrak{C}, \mathfrak{D}$ be the G -crossed braided categories obtained from C, D , respectively, from Theorem 4.11, and let $(\mathbf{A}, \mathbf{a}), (\mathbf{B}, \mathbf{b}) : \mathfrak{C} \rightarrow \mathfrak{D}$ be the G -crossed braided functors obtained from A, B , respectively, from Theorem 4.14. In Construction 4.16, we defined $h : (\mathbf{A}, \mathbf{a}) \Rightarrow (\mathbf{B}, \mathbf{b})$ by $h_a := \eta_a \in D(\mathbf{A}(a) \Rightarrow \mathbf{B}(a))$ for $a \in \mathfrak{C}_g = C(1_C \rightarrow g_C)$.

Proof of Theorem 4.17: $h : (\mathbf{A}, \mathbf{a}) \Rightarrow (\mathbf{B}, \mathbf{b})$ is a G -crossed braided monoidal transformation.

Naturality: This is immediate by the definition $h_x := \eta_x$ for $x \in \mathfrak{C}_g = C(1_C \rightarrow g_C)$ and (T-II).i.

Unitality: By (T-II).iii. $h_{1_G} = \eta_{id_{g_C}} = B_e^1 * (A_e^1)^{-1} = \mathbf{B}^1 * (\mathbf{A}^1)^{-1}$.

Monoidality: That $\mathbf{B}_{x,y}^2 * (h_x \otimes h_y) = h_{x \otimes y} * \mathbf{A}_{x,y}^2$ follows immediately by (T-IV).

((18)) For $x \in \mathfrak{C}_h = C(1_C \rightarrow h_C)$, we use the following shorthand as in Notation B.1. We also draw red strands to denote id_g in D , and we draw unshaded boxes on red strands to denote each of $A(id_{g_C}), A(id_{g_C}^{-1})$ and $B(id_{g_C}), B(id_{g_C}^{-1})$. For example,

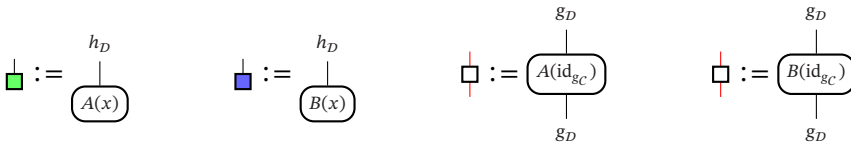

The outside of the commuting diagram below corresponds to (18).

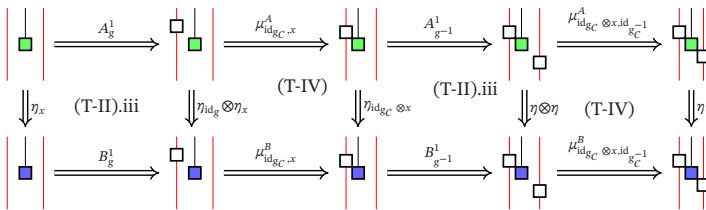

This completes the proof. \square

C.2 | Coherence proofs for the equivalence Subsection 4.3

In this section, we supply the proofs from Subsection 4.3 which prove that the strict 2-functor $3Cat_G^{st} \rightarrow GCrsBrd^{st}$ from Theorem 4.18 is an equivalence. We begin by expanding on Notation B.1.

Notation C.2. In this section, we use an expanded shorthand notation for 1-cells in \mathcal{D} and \mathfrak{D} for proofs using commutative diagrams. For $x_1 \in C(g_C \rightarrow h_C)$, $x_2 \in C(h_C \rightarrow k_C)$, $y_1 \in C(p_C \rightarrow q_C)$, and $y_2 \in C(q_C \rightarrow r_C)$, we will denote the image under \mathbf{A} after tensoring with the identity of the source object using small shaded squares with one strand coming out of the top, for example,



We denote the G -actions $F_g^{\mathfrak{D}}$ and $F_h^{\mathfrak{D}}$ as in Construction 4.10 by a red strand underneath the 1-morphism in \mathcal{C} , where red corresponds to g and green corresponds to h . We denote \mathbf{A} applied to the G -actions $F_g^{\mathfrak{C}}$ and $F_h^{\mathfrak{C}}$ by outlining the shaded square with red or green, respectively, for example,

$$\begin{array}{c} \text{red outline} \end{array} := \begin{array}{c} gqp^{-1}g_D^{-1} \\ | \\ \text{red box} \\ | \\ F_g^{\mathfrak{D}}(\mathbf{A}(x_2 \otimes p_C^{-1})) \end{array} \quad
 \begin{array}{c} \text{green outline} \end{array} := \begin{array}{c} gqp^{-1}g_D^{-1} \\ | \\ \text{green box} \\ | \\ \mathbf{A}(F_g^{\mathfrak{C}}(x_2 \otimes p_C^{-1})) \end{array} \quad
 \begin{array}{c} \text{red outline} \end{array} := \begin{array}{c} hrq^{-1}h_D^{-1} \\ | \\ \text{red box} \\ | \\ F_h^{\mathfrak{D}}(\mathbf{A}(y_2 \otimes q_C^{-1})) \end{array} \quad
 \begin{array}{c} \text{green outline} \end{array} := \begin{array}{c} hrq^{-1}h_D^{-1} \\ | \\ \text{green box} \\ | \\ \mathbf{A}(F_h^{\mathfrak{C}}(y_2 \otimes q_C^{-1})) \end{array}$$

We use a similar convention for the \otimes composite of 1-cells as in Notation B.1. For example, if $x \in \mathfrak{C}_g = \mathcal{C}(1_C \rightarrow g_C)$ and $y \in \mathfrak{C}_h = \mathcal{C}(1_C \rightarrow h_C)$, we write

$$\begin{array}{c} \text{white box} \end{array} := \begin{array}{c} hg_D^{-1} \\ | \\ \text{white box} \\ | \\ \mathbf{A}(x) \end{array} \quad
 \begin{array}{c} \text{blue box} \end{array} := \begin{array}{c} qp_D^{-1} \\ | \\ \text{blue box} \\ | \\ \mathbf{A}(y) \end{array} \quad
 \begin{array}{c} \text{white box} \\ | \\ \text{blue box} \end{array} := \begin{array}{c} g_C \quad h_C \\ | \quad | \\ \text{white box} \otimes \text{blue box} \\ | \\ \mathbf{A}(x) \otimes \mathbf{A}(y) \end{array} \quad
 \begin{array}{c} \text{white box} \\ | \\ \text{blue box} \end{array} := \begin{array}{c} g_C \otimes h_C \\ | \\ \text{white box} \otimes \text{blue box} \\ | \\ \mathbf{A}(x \otimes y) \end{array} .$$

This means that by Construction 4.10 of the G -crossed braiding in \mathfrak{C} , we have that

$$\begin{array}{c} \text{white box} \\ | \\ \text{red box} \end{array} \xrightarrow{\mathbf{A}\left(\beta_{x_1 \otimes g_C^{-1}, F_g^{\mathfrak{C}}(y_2 \otimes q_C^{-1})}^{hg^{-1}, gq^{-1}g^{-1}}\right)} \begin{array}{c} \text{green box} \\ | \\ \text{white box} \end{array} .$$

Proof of Lemma 4.21: $(A, A^1, A^2) : \mathcal{C} \rightarrow \mathcal{D}$ is a 2-functor.

(F-I).i For $x \in \mathcal{C}(g_C \rightarrow h_C)$, $y \in \mathcal{C}(h_C \rightarrow k_C)$, and $z \in \mathcal{C}(k_C \rightarrow \ell_C)$, using the nudging convention (8), the square for A^2 is exactly

$$\begin{array}{ccc}
 \underbrace{\mathbf{A}(z \otimes k_C^{-1}) \otimes \mathbf{A}(y \otimes h_C^{-1}) \otimes \mathbf{A}(x \otimes g_C^{-1}) \otimes g_D}_{A(z) \circ A(y) \circ A(x)} & \xrightarrow{\text{id}_{\mathbf{A}(z \otimes k_C^{-1})} \otimes \mathbf{A}^2 \otimes \text{id}_{g_D}} & \underbrace{\mathbf{A}(z \otimes k_C^{-1}) \otimes \mathbf{A}(y \otimes h_C^{-1} \otimes x \otimes g_C^{-1}) \otimes g_D}_{A(z) \circ A(y \circ x)} \\
 \downarrow \mathbf{A}^2 \otimes \text{id}_{\mathbf{A}(x \otimes g_C^{-1})} \otimes \text{id}_{g_D} & & \downarrow \mathbf{A}^2 \otimes \text{id}_{g_D} \\
 \underbrace{\mathbf{A}(z \otimes k_C^{-1} \otimes y \otimes h_C^{-1}) \otimes \mathbf{A}(x \otimes g_C^{-1}) \otimes g_D}_{A(z \circ y) \circ A(x)} & \xrightarrow{\mathbf{A}^2 \otimes \text{id}_{g_D}} & \underbrace{\mathbf{A}((z \otimes k_C^{-1}) \otimes (y \otimes h_C^{-1}) \otimes (x \otimes g_C^{-1})) \otimes g_D}_{A(z \circ y \circ x)}
 \end{array}$$

which commutes by strictness of \mathfrak{C} , \mathfrak{D} and associativity of \mathbf{A}^2 .

(F-I).ii For $x \in \mathcal{C}(g_C \rightarrow h_C)$, using the nudging convention (8), the lower triangle for A^1 and A^2 is exactly

$$\begin{array}{ccc}
 \underbrace{e_D \otimes \mathbf{A}(x \otimes g_C^{-1}) \otimes g_D}_{A(x)} & & \\
 \downarrow \mathbf{A}^1 \otimes \text{id}_{\mathbf{A}(x \otimes g_C^{-1})} \otimes \text{id}_{g_D} & \searrow \text{id}_x & \\
 \underbrace{\mathbf{A}(e_C) \otimes \mathbf{A}(x \otimes g_C^{-1}) \otimes g_D}_{A(\text{id}_h) \circ A(x)} & \xrightarrow{\mathbf{A}^2 \otimes \text{id}_{g_D}} & \underbrace{\mathbf{A}(e_C \otimes x \otimes g_C^{-1}) \otimes g_D}_{A(x)}
 \end{array}$$

which commutes by unitality of $\mathbf{A}^1, \mathbf{A}^2$. The other triangle is similar. □

Proof of Theorem 4.23: $(A, \mu^A, \iota^A) \in 3\text{Cat}_G^{\text{st}}(\mathcal{C} \rightarrow \mathcal{D})$.

(F-II).i Each component in the definition of $\mu_{y,x}^A$ is natural in x and y .

(F-II).ii For $g, h \in G$, $x_1 \in C(g_C \rightarrow h_C)$, $x_2 \in C(h_C \rightarrow k_C)$, $y_1 \in C(p_C \rightarrow q_C)$, and $y_2 \in C(q_C \rightarrow r_C)$, we use the following shorthand as in Notation B.1:

$$\square := \begin{array}{c} hg_D^{-1} \\ \text{A}(x_1 \otimes g_C^{-1}) \end{array} \quad \blacksquare := \begin{array}{c} kh_D^{-1} \\ \text{A}(y_1 \otimes h_C^{-1}) \end{array} \quad \blacksquare := \begin{array}{c} qp_D^{-1} \\ \text{A}(x_2 \otimes p_C^{-1}) \end{array} \quad \blacksquare := \begin{array}{c} rq_D^{-1} \\ \text{A}(y_2 \otimes q_C^{-1}) \end{array}$$

Observe that by the definition of A from **A** and the nudging convention (8), we have

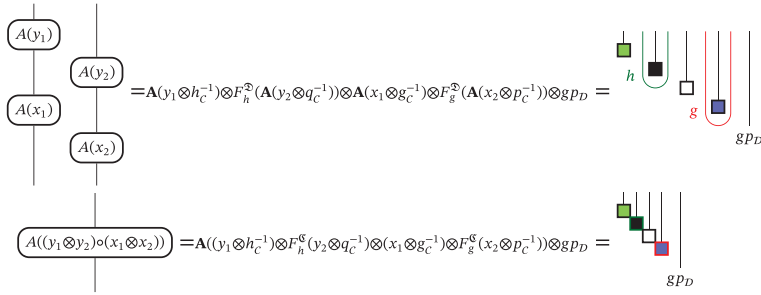

Going around the outside of the diagram below corresponds to (F-II).ii, except we leave off the extra gp_D strand on the right-hand side of each string diagram.

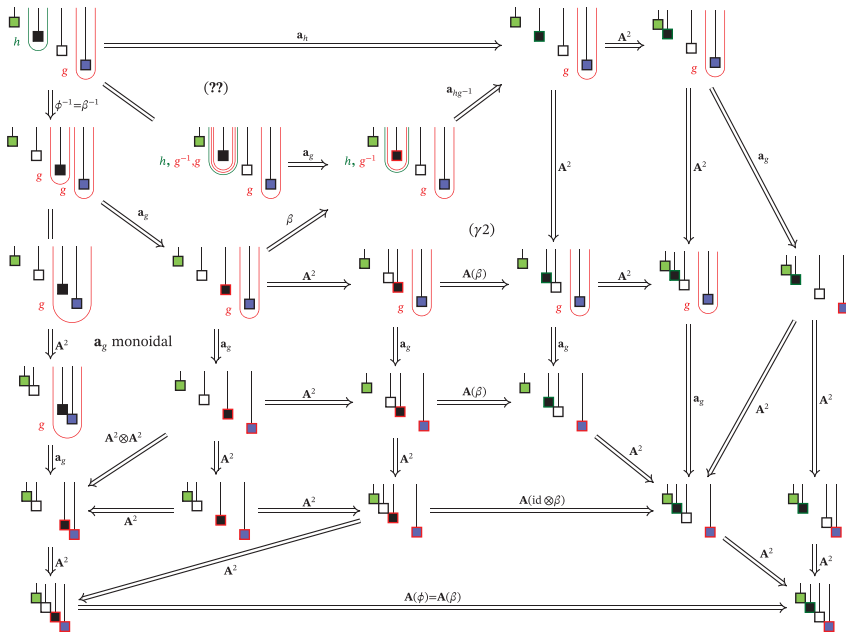

The faces without labels above commute either by naturality or by associativity of A^2 .

(F-II).iii This follows since each F_g^D is strictly unital, and thus for all $g \in G$,

$$\mathbf{A}_e^1 = \mathbf{A}_{\text{id}_e, \text{id}_e}^2 * (\mathbf{A}_e^1 \otimes \mathbf{A}_e^1) = \mathbf{A}_{\text{id}_e, F_g^D(\text{id}_e)}^2 * (\mathbf{A}_e^1, F_g^D(\mathbf{A}_e^1)).$$

(F-III) This part is automatic as $\iota_1^A = \mathbf{A}_e^1$.

(F-IV) This follows by monoidality of \mathbf{a}_g and associativity of \mathbf{A}^2 . We omit the full proof as it is much easier than (F-II).ii above.

(F-V) This reduces to unitality of \mathbf{A}^1 and \mathbf{A}^2 , that is, for all $x \in \mathcal{C}(g_C \rightarrow h_C)$,

$$\mathbf{A}^2_{\text{id}_e, x \otimes g_C^{-1}} * (\mathbf{A}^1 \otimes \text{id}_{\mathbf{A}(x \otimes g_C^{-1})}) = \text{id}_{\mathbf{A}(x \otimes g_C^{-1})}.$$

The other unitality axiom is similar.

(F-1) Every map is the identity map.

(F-2) Every map is the identity map. □

Proof of Theorem 4.24: The map $3\text{Cat}_G^{\text{st}}(A \Rightarrow B) \rightarrow G\text{CrSBrd}(\mathbf{A} \Rightarrow \mathbf{B})$ is bijective. Suppose that $\eta, \zeta \in 3\text{Cat}_G^{\text{st}}(A \Rightarrow B)$ satisfy $\eta_x = \zeta_x$ for every $x \in \mathcal{C}(1_C \rightarrow g_C)$ for all $g \in G$. Since η, ζ are 2-morphisms in $3\text{Cat}_G^{\text{st}}$, we have $\eta_* = e_D = \zeta_*$, $\eta_g = \text{id}_{g_D} = \zeta_g$ for all $g \in G$. For an arbitrary $y \in \mathcal{C}(g_C \rightarrow h_C)$, we have $\eta_{y \otimes g_C^{-1}} = \zeta_{y \otimes g_C^{-1}}$. By (T-IV) for $\eta : A \Rightarrow B$, the following diagram commutes:

$$\begin{array}{ccc}
 \begin{array}{c} hg_D^{-1} \\ \downarrow \\ A(y \otimes g_C^{-1}) \end{array} & \begin{array}{c} g_D \\ \downarrow \\ A(g_C) \end{array} & \xrightarrow{\mu^A} & \begin{array}{c} g_D \\ \downarrow \\ A(y) \end{array} \\
 & \downarrow g_D & & \downarrow g_D \\
 & \eta_{y \otimes g_C^{-1}} \otimes \eta_{\text{id}_{g_C}} & & \eta_y \\
 \begin{array}{c} hg_D^{-1} \\ \downarrow \\ B(y \otimes g_C^{-1}) \end{array} & \begin{array}{c} g_D \\ \downarrow \\ B(g_C) \end{array} & \xrightarrow{\mu^B} & \begin{array}{c} g_D \\ \downarrow \\ B(y) \end{array} \\
 & \downarrow g_D & & \downarrow g_D
 \end{array} \tag{C.2}$$

as does a similar diagram for ζ replacing η . Since $\eta_{y \otimes g_C^{-1}} = \zeta_{y \otimes g_C^{-1}}$ by assumption, $\eta_{\text{id}_g} = B_g^1 * (A_g^1)^{-1} = \zeta_{\text{id}_g}$ by (T-II).iii, and μ^A, μ^B are invertible 2-cells, we conclude that $\eta_x = \zeta_x$.

Now suppose $h : \mathbf{A} \Rightarrow \mathbf{B}$ is a G -monoidal natural transformation. We define $\eta : A \Rightarrow B$ by $\eta_* = e_D, \eta_g = \text{id}_{g_D}$ for all $g \in G$, and for $y \in \mathcal{C}(g_C \rightarrow h_C)$, we use (C.2) above to define

$$\eta_y := \mu^B_{y \otimes g_C^{-1}, g_C} * (h_{y \otimes g_C^{-1}} \otimes (B_g^1 * (A_g^1)^{-1})) * (\mu^A_{y \otimes g_C^{-1}, g_C})^{-1}.$$

By construction, provided η is a transformation $\eta \mapsto h$. It remains to verify that $\eta : A \Rightarrow B$ is indeed a transformation. We prove one of the coherences below, and we give a hint as how to proceed for the other coherences.

- (T-II).i Every composite step in the definition of η is natural.
- (T-II).ii This follows from functoriality of 1-cell composition \circ together with the fact that h is monoidal, and two instances each (one for each of A and B) of (F-I).ii, (C.1), and (F-IV).
- (T-II).iii This follows using two instances of (F-II).iii (one for each of A and B) together with the fact that

$$h_{\text{id}_e} = \mathbf{B}^1 \otimes (\mathbf{A}^1)^{-1} = B_e^1 * (A_e^1)^{-1}$$

which is unitality for a monoidal natural transformation.

- (T-III) This condition is automatically satisfied.
- (T-IV) For $x \in \mathcal{C}(g_C \rightarrow h_C)$ and $y \in \mathcal{C}(k_C \rightarrow \ell_C)$, we use the following shorthand as in Notation B.1 and Notation C.2:

$$\begin{array}{cccccc}
 \begin{array}{c} h_D \\ \square := A(x) \\ g_D \end{array} & \square := hg_D^{-1} & \begin{array}{c} \ell_D \\ \square := A(y) \\ k_D \end{array} & \square := \ell k_D^{-1} & \begin{array}{c} j_D \\ \square := A(\text{id}_{j_C}) \\ j_D \end{array} & \forall j \in G. \\
 \begin{array}{c} h_D \\ \square := B(x) \\ g_D \end{array} & \square := hg_D^{-1} & \begin{array}{c} \ell_D \\ \square := B(y) \\ k_D \end{array} & \square := \ell k_D^{-1} & \begin{array}{c} j_D \\ \square := B(\text{id}_{j_C}) \\ j_D \end{array} & \forall j \in G.
 \end{array}$$

Suppose $x \in C(g_C \rightarrow h_C)$ and $y \in C(k_C \rightarrow \ell_C)$. We begin with the following observation that the following diagram commutes:

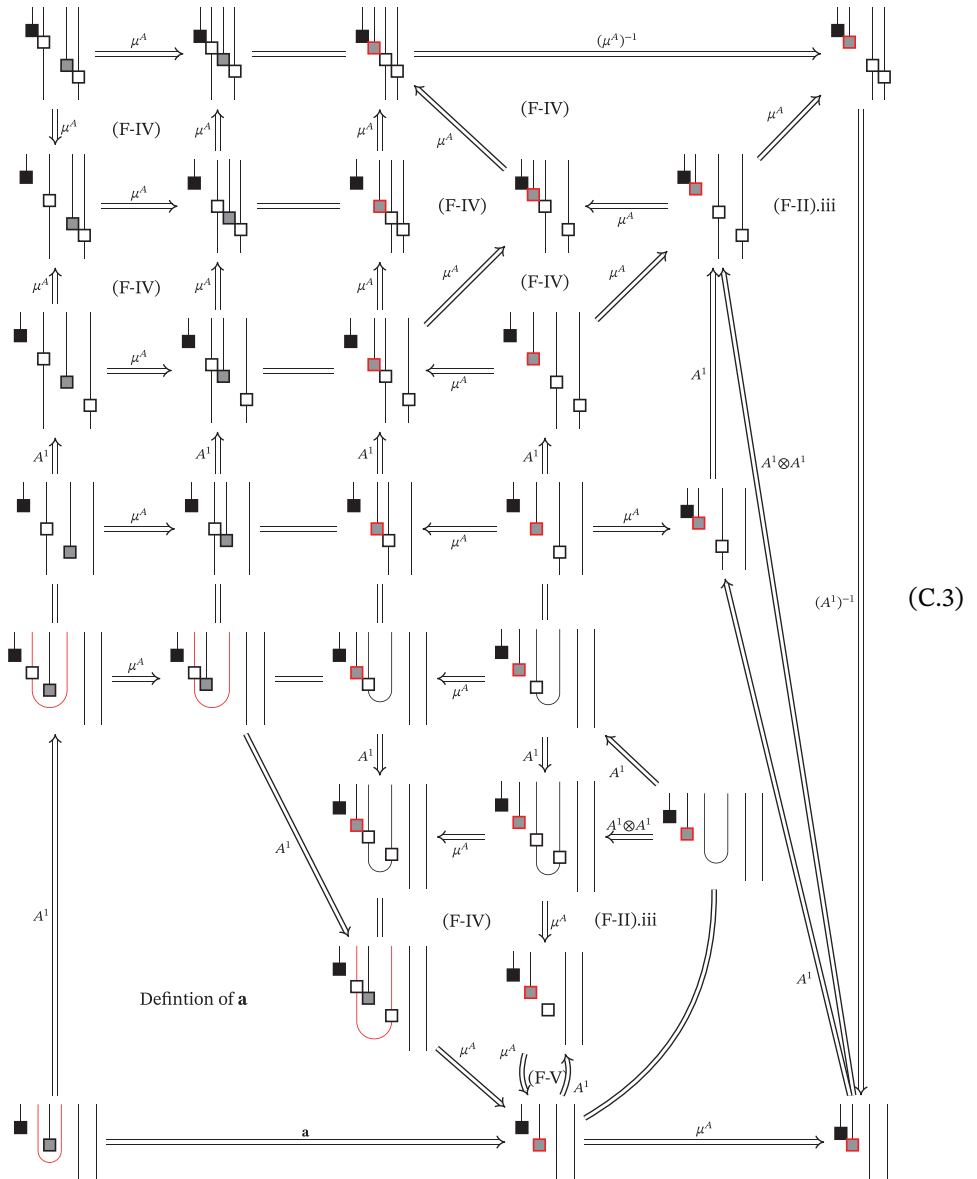

Observe that (C.3) above also holds with $(A, A^1, \mu^A, \mathbf{A}, \mathbf{a})$ replaced by $(B, B^1, \mu^B, \mathbf{B}, \mathbf{b})$. Going around the outside of the diagram below corresponds to (T-IV), where we also use the abuse of notation of h for $B^1 * (A^1)^{-1}$.

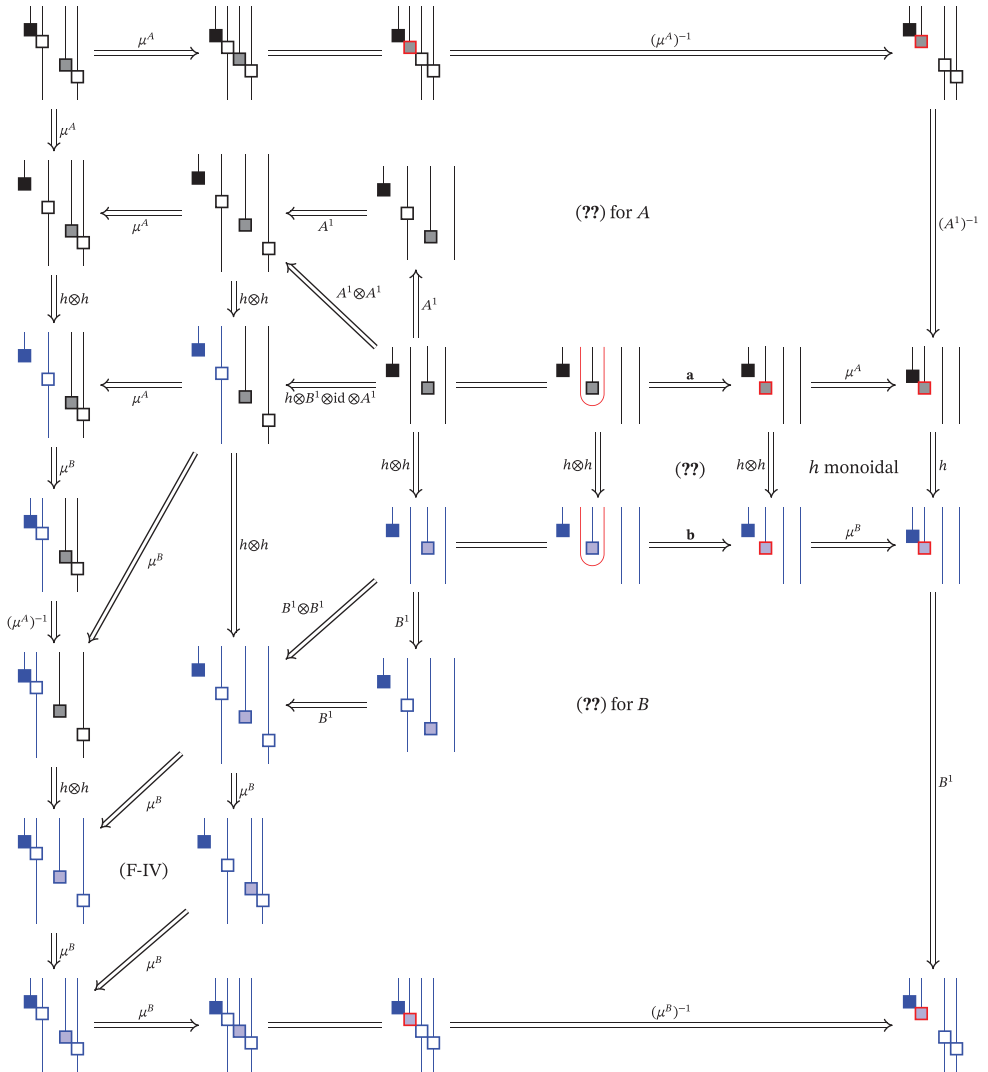

The faces without labels above commute by functoriality of 1-cell composition \circ or by the shorthand $h = B^1 * (A^1)^{-1}$.

- (T-1) Every map is the identity map.
- (T-2) Every map is the identity map. □

ACKNOWLEDGEMENTS

The authors would like to thank Shawn Cui, Nick Gurski, Niles Johnson, and André Henriques for helpful conversations. This material is based upon work supported by the National Science Foundation under Grant Number: DMS-1440140, while the authors David Penneys and David Reutter were in residence at the Mathematical Sciences Research Institute in Berkeley, California, dur-

ing the Spring 2020 semester. Corey Jones was supported by NSF DMS, Grant Number: 1901082. David Penneys was supported by NSF DMS, Grant Number: 1654159. David Reutter is grateful for the financial support and hospitality of the Max Planck Institute for Mathematics where part of this work was carried out.

JOURNAL INFORMATION

The *Journal of the London Mathematical Society* is wholly owned and managed by the London Mathematical Society, a not-for-profit Charity registered with the UK Charity Commission. All surplus income from its publishing programme is used to support mathematicians and mathematics research in the form of research grants, conference grants, prizes, initiatives for early career researchers and the promotion of mathematics.

REFERENCES

1. J. C. Baez and J. Dolan, *Higher-dimensional algebra and topological quantum field theory*, J. Math. Phys. **36** (1995), no. 11, 6073–6105. MR1355899, arXiv:q-alg/9503002. <https://doi.org/10.1063/1.531236>
2. J. C. Baez and M. Shulman, *Lectures on n -categories and cohomology. Towards higher categories*, IMA Vol. Math. Appl., vol. 152, Springer, New York, 2010, pp. 1–68. MR2664619, arXiv:math/0608420.
3. M. Barkeshli, P. Bonderson, M. Cheng, and Z. Wang, *Symmetry fractionalization, defects, and gauging of topological phases*, Phys. Rev. B **100** (2019), 115147. arXiv:1410.4540. <https://doi.org/10.1103/PhysRevB.100.115147>
4. J. W. Barrett, C. Meusburger, and G. Schaumann, *Gray categories with duals and their diagrams*, arXiv:1211.0529, 2012.
5. B. Bartlett, *Quasistrict symmetric monoidal 2-categories via wire diagrams*, arXiv:1409.2148, 2014.
6. A. Bartels, C. L. Douglas, and A. Henriques, *Conformal nets I: Coordinate-free nets*, Int. Math. Res. Not. (2015), no. 13, 4975–5052. MR3439097, arXiv:1302.2604. <https://doi.org/10.1093/imrn/rnu080>
7. A. Bartels, C. L. Douglas, and A. Henriques, *Conformal nets II: Conformal blocks*, Comm. Math. Phys. **354** (2017), no. 1, 393–458. MR3656522, arXiv:1409.8672. <https://doi.org/10.1007/s00220-016-2814-5>
8. A. Bartels, C. L. Douglas, and A. Henriques, *Conformal nets IV: The 3-category*, Algebr. Geom. Topol. **18** (2018), no. 2, 897–956. MR3773743, arXiv:1605.00662. <https://doi.org/10.2140/agt.2018.18.897>
9. A. Bartels, C. L. Douglas, and A. Henriques, *Fusion of defects*, Mem. Amer. Math. Soc. **258** (2019), no. 1237, vii+100. MR3927541, arXiv:1310.8263.
10. E. Bernaschini, C. Galindo, and M. Mombelli, *Group actions on 2-categories*, Manuscripta Math. **159** (2019), no. 1–2, 81–115. MR3936135, arXiv:1702.02627. <https://doi.org/10.1007/s00229-018-1031-2>
11. O. Braunling, *Quinn’s formula and abelian 3-cocycles for quadratic forms*, Algebr. Represent. Theory **24** (2021), no. 6, 1523–1555. MR4340851.
12. L. Buhné, *Homomorphisms of Gray-categories as pseudo algebras*, arXiv:1408.3481, 2014.
13. L. Buhné, *Topics in three-dimensional descent theory*, Ph.D. thesis, Fakultät für Mathematik, Informatik und Naturwissenschaften Fachbereich Mathematik der Universität Hamburg, 2015. <https://d-nb.info/1072553694/34>
14. E. Cheng and N. Gurski, *The periodic table of n -categories II: Degenerate tricategories*, Cah. Topol. Géom. Différ. Catég. **52** (2011), no. 2, 82–125. MR2839900, arXiv:0706.2307.
15. S. X. Cui, *Four dimensional topological quantum field theories from G -crossed braided categories*, Quantum Topol. **10** (2019), no. 4, 593–676. MR4033513, arXiv:610.07628. <https://doi.org/10.4171/qt/128>
16. S. X. Cui, C. Galindo, J. Y. Plavnik, and Z. Wang, *On gauging symmetry of modular categories*, Comm. Math. Phys. **348** (2016), no. 3, 1043–1064. MR3555361. <https://doi.org/10.1007/s00220-016-2633-8>
17. C. Delaney, C. Galindo, J. Plavnik, E. C. Rowell, and Q. Zhang, *Braided zesting and its applications*, Comm. Math. Phys. **386** (2021), no. 1, 1–55. MR4287180, arXiv:2005.05544. <https://doi.org/10.1007/s00220-021-04002-4>
18. C. Douglas and A. Henriques, *Internal bicategories*, arXiv:1206.4284, 2012.
19. C. L. Douglas and D. J. Reutter, *Fusion 2-categories and a state-sum invariant for 4-manifolds*, arXiv:1812.11933, 2018.

20. C. L. Douglas, C. Schommer-Pries, and N. Snyder, *Dualizable tensor categories*, Mem. Amer. Math. Soc. **268** (2020), no. 1308, vii+88. MR4254952, arXiv:1312.7188. <https://doi.org/10.1090/memo/1308>
21. S. Eilenberg and S. MacLane, *On the groups $H(\Pi, n)$. III*, Ann. of Math. (2) **60** (1954), 513–557. MR65163. <https://doi.org/10.2307/1969849>
22. P. Etingof, S. Gelaki, D. Nikshych, and V. Ostrik, *Tensor categories*, Mathematical Surveys and Monographs, vol. 205, American Mathematical Society, Providence, RI, 2015. MR3242743. <https://doi.org/10.1090/surv/205>
23. P. Etingof, D. Nikshych, and V. Ostrik, *Fusion categories and homotopy theory*, Quantum Topol. **1** (2010), no. 3, 209–273, 2677836, arXiv:0909.3140. <https://doi.org/10.4171/QT/6>. (With an appendix by Ehud Meir.)
24. G. Ferrer, *Gray-categories model algebraic tricategories*, Theory Appl. Categ. **38** (2022), Paper No. 29, 1136–1155. MR4483628.
25. D. Gaiotto and T. Johnson-Freyd, *Condensations in higher categories*, arXiv:1905.09566, 2019.
26. D. Gaiotto and T. Johnson-Freyd, *Symmetry protected topological phases and generalized cohomology*, J. High Energy Phys. (2019), no. 5, 007, 34. MR3978827, arXiv:1712.07950.
27. C. Galindo, *Coherence for monoidal G -categories and braided G -crossed categories*, J. Algebra **487** (2017), 118–137. MR3671186, arXiv:1604.01679. <https://doi.org/10.1016/j.jalgebra.2017.05.027>
28. T. Gannon and C. Jones, *Vanishing of categorical Obstructions for Permutation Orbifoldscategorical obstructions for permutation orbifolds*, Comm. Math. Phys. **369** (2019), no. 1, 245–259. MR3959559, arXiv:1804.08343. <https://doi.org/10.1007/s00220-019-03288-9>
29. S. Gelaki, D. Naidu, and D. Nikshych, *Centers of graded fusion categories*, Algebra Number Theory **3** (2009), no. 8, 959–990. MR2587410, arXiv:0905.3117. <https://doi.org/10.2140/ant.2009.3.959>
30. R. Gordon, A. J. Power, and R. Street, *Coherence for tricategories*, Mem. Amer. Math. Soc. **117** (1995), no. 558, vi+81. MR1261589. <https://doi.org/10.1090/memo/0558>
31. J. Greenough, *Monoidal 2-structure of bimodule categories*, J. Algebra **324** (2010), no. 8, 1818–1859. MR2678824, arXiv:0911.4979. <https://doi.org/10.1016/j.jalgebra.2010.06.018>
32. P. Grossman, S. Morrison, D. Penneys, E. Peters, and N. Snyder, *The extended Haagerup fusion categories*, Ann. Sci. Éc. Norm. Supér. (2018), arXiv:1810.06076, to appear.
33. M. N. Gurski, *An algebraic theory of tricategories*, ProQuest LLC, Ann Arbor, MI, 2006, Ph.D. thesis, The University of Chicago, MR2717302. <https://gauss.math.yale.edu/~mg622/tricats.pdf>
34. N. Gurski, *Biequivalences in tricategories*, Theory Appl. Categ. **26** (2012), no. 14, 349–384. MR2972968, arXiv:1102.0979.
35. N. Gurski, *Coherence in three-dimensional category theory*, Cambridge Tracts in Mathematics, vol. 201, Cambridge University Press, Cambridge, 2013. MR3076451. <https://doi.org/10.1017/CBO9781139542333>
36. P. Guthmann, *The tricategory of formal composites and its strictification*, arXiv:1903.05777, 2019.
37. R. Haugseng, *The higher Morita category of E_n -algebras*, Geom. Topol. **21** (2017), no. 3, 1631–1730. MR3650080. <https://doi.org/10.2140/gt.2017.21.1631>
38. A. Henriques, D. Penneys, and J. E. Tener, *Planar algebras in braided tensor categories*, Mem. Amer. Math. Soc. (2016), arXiv:1607.06041, to appear.
39. M. Izumi, *A Cuntz algebra approach to the classification of near-group categories*, Proceedings of the 2014 Maui and 2015 Qinhuangdao Conferences in Honour of Vaughan F. R. Jones' 60th birthday, Proc. Centre Math. Appl., Austral. Nat. Univ., vol. 46, Australian National University, Canberra, 2017, pp. 222–343. MR3635673, arXiv:1512.04288.
40. T. Johnson-Freyd and C. Scheimbauer, *(Op)lax natural transformations, twisted quantum field theories, and “even higher” Morita categories*, Adv. Math. **307** (2017), 147–223. MR3590516, arXiv:1502.06526. <https://doi.org/10.1016/j.aim.2016.11.014>
41. V. Jones, *Planar algebras*, New Zealand J. Math. **52** (2021), 1–107, arXiv:math.QA/9909027.
42. G. M. Kelly, *Basic concepts of enriched category theory*, Repr. Theory Appl. Categ. (2005), no. 10, vi+137. MR2177301. (Reprint of the 1982 original [Cambridge Univ. Press, Cambridge; MR0651714]).
43. A. Kirillov, Jr, *Modular categories and orbifold models ii*, arXiv:math/0110221, 2001.
44. A. Kirillov, Jr, *Modular categories and orbifold models*, Comm. Math. Phys. **229** (2002), no. 2, 309–335. MR1923177. <https://doi.org/10.1007/s002200200650>
45. S. Lack, *A Quillen model structure for Gray-categories*, J. K-Theory **8** (2011), no. 2, 183–221. MR2842929, arXiv:1001.2366. <https://doi.org/10.1017/is010008014jkt127>

46. J. Lurie, *Higher topos theory*, Annals of Mathematics Studies, vol. 170, Princeton University Press, Princeton, NJ, 2009. MR2522659. <https://doi.org/10.1515/9781400830558>
47. J. Lurie, *On the classification of topological field theories*. Current developments in mathematics, 2008, Int. Press, Somerville, MA, 2009, pp. 129–280. MR2555928, arXiv:0905.0465.
48. S. MacLane, *Cohomology theory of Abelian groups*, Proceedings of the International Congress of Mathematicians, Cambridge, MA, 1950, vol. 2, Amer. Math. Soc., Providence, RI, 1952, pp. 8–14. MR0045115.
49. M. Müger, *Conformal orbifold theories and braided crossed G -categories*, Comm. Math. Phys. **260** (2005), no. 3, 727–762. MR2183964, arXiv:math/0403322. <https://doi.org/10.1007/s00220-005-1291-z>
50. L. Müller and L. Woike, *The little bundles operad*, arXiv:1901.04850, 2019.
51. D. Reutter, *Higher linear algebra in topology and quantum information theory*, Ph.D. thesis, University of Oxford, 2019. <https://ora.ox.ac.uk/objects/uuid:0b26d9f5-0e6e-4b81-b02d-a92820a3803a>
52. C. Schweigert and L. Woike, *Extended homotopy quantum field theories and their orbifoldization*, J. Pure Appl. Algebra **224** (2020), no. 4, 106213, 42 pp. MR4021927.
53. V. Turaev, *Homotopy quantum field theory*, EMS Tracts in Mathematics, vol. 10, European Mathematical Society (EMS), Zürich, 2010, MR2674592. <https://doi.org/10.4171/086>. (Appendix 5 by Michael Müger and Appendices 6 and 7 by Alexis Virelizier.)