

Malagasy clause structure

Ileana M. Paul

Department of Linguistics
McGill University
Montreal, Canada

A thesis submitted to the Faculty of Graduate Studies
in partial fulfillment of the requirements
of the degree of Doctor of Philosophy

January 2000

©2000 Ileana M. Paul

voasary amoron-dalana

haka aho

tsy tompony

tsy haka aho

maha te-hihinana

'a lemon by the road

if I take it

I will not be its master

if I don't take it

I will want to eat it'

-Malagasy proverb

Abstract

This thesis explores the nature of voice in Malagasy, a language spoken in Madagascar. In chapter 2, it is claimed that different passives promote arguments from different structural positions. Evidence is provided for a particular position, [Spec, v2P], where a certain class of elements (“displaced themes”) may be generated. One particular passive, the *a*-prefix, promotes to subject elements in this position. In chapter 3, arguments are presented in favour of a structural analysis of circumstantial topic (CT). CT morphology licenses all arguments of the verb. Due to a requirement that all clauses have a subject (the Extended Projection Principle), some element other than a DP structurally Case marked by the verb must raise to subject. Finally, chapter 4 addresses the left periphery in the Malagasy clause, in particular the structural positions of topic and focus.

Résumé

Dans cette thèse, il est question du statut de la voix en Malgache, langue parlée à Madagascar. Dans chapitre 2, il est avancé que des arguments différents montent à la position du sujet lorsque le verbe porte les différents affixes passifs. Certains arguments (des “thèmes déplacés”) peuvent être générés dans [Spec, v2P]. Si le verbe porte le préfixe *a*-, un argument généré dans [Spec, v2P] monte à la position du sujet. Dans chapitre 3, il s’agit d’une analyse structurale de la construction “circumstantial topic” (CT). La morphologie CT license tous les arguments du verbe. À cause du “Extended Projection Principle”, un élément sans cas structural doit assumer la fonction du sujet. Dans chapitre 4, il est question de la périphérie gauche de la clause, en particulier, les positions “topic” et “focus”.

Acknowledgments

So many people touch one's career as a graduate student. Since I cannot mention everyone, I will err on the side of brevity.

I first want to thank Lisa Travis, my advisor. Lisa has been a source of inspiration, from my first baby steps in syntax to the last line of this thesis. I have benefited not only from her great sense of reasoning and knowledge of syntax and Malagasy, but also from her friendship.

All the professors, students and staff at the department of linguistics at McGill deserve thanks for their help along the way. I want to express my special appreciation to Mark Baker for many stimulating. Jonathan Bobaljik very generously offered comments on versions of chapter 2 during his summer holiday.

A warm thank you to Ed Keenan for offering me the chance to do field work with him in Madagascar in 1995 and for his continued encouragement over the years. Further appreciation to Roger-Bruno Rabenilaina and the other linguists at the Université d'Antananarivo for their hospitality during my stay in Madagascar.

This thesis would not exist without the patience and insight of my Malagasy consultants in Montreal: Saholy Hanitriniaina, Michèle Ratovonony and Julie Rabemananjara. *Misoatra betsaka, tompoko!* I thank McGill and FCAR for funding which made this research possible.

In the greater linguistics community, several people have provided invaluable feedback. I would like to thank the audiences at the AFLA conferences for their input and support, especially Bill Davies, Diane Massam, Matt Pearson, Peter Cole and Gabriella Hermon. *Salamat* to Norvin Richards for his comments and for kindly answering my last-minute, panic-ridden email messages.

Finally, I want to thank my friends, the Biomass (Martyna Kozłowska, Lara Riente and Jila Ghomesi), for reminding me to enjoy life and for teaching me how to drink vodka. Thanks also to my ex in-laws for all their support. My family, especially my parents, have been wonderfully generous with love and understanding.

I dedicate this thesis to Felix, my ray of sunshine.

List of Abbreviations

1-first person
2-second person
3-third person
abs-absolutive
acc-accusative
asp-aspect
AT-Actor Topic
AV-Actor Voice
ben-benefactive
BT-Benefactive Topic
C-complementizer
CT-Circumstantial Topic
def-definite determiner
det-determiner
erg-ergative
ex-exclamative
excl-exclusive
foc-focus particle
fut-future
gen-genitive
incl-inclusive
IT-Instrumental Topic
LT-Locative Topic
neg-negation
nm-nominalizer
nom-nominative
NPI-negative polarity item
obl-oblique
opt-optative
OV-Object Voice
P-preposition
part-partitive
pass-passive
perf-perfective
pl-plural
pres-present
pst-past
Q-question marker
rel-relative marker
sg-singular
sp-subject prefix
top-topic particle
trans-transitivizer
TT- Theme Topic

Table of contents

Abstract.....	i
Acknowledgements.....	ii
Abbreviations	iii
Table of contents	iv
Chapter 1: Introduction	1
1 Voice.....	1
2 Voice in Austronesian.....	4
2.1 Structure.....	4
2.2 Semantics.....	5
2.3 Theta roles.....	6
3 Malagasy.....	7
3.1 Word order.....	8
3.2 Voice.....	12
3.3 Morphology.....	13
4 Theoretical assumptions.....	16
5 Organization of the thesis	17
Chapter 2: Theme Topic.....	19
1 Introduction.....	19
2 Passive in Malagasy.....	20
2.1 Passive formation.....	23
2.2 a- passive vs. -Vna passive: basic distribution.....	25
2.2.1 One passive.....	25
2.2.2 Two passives	26
2.2.3 Which passive?.....	31
2.3 Locative alternation and instrumental advancement.....	33
2.3.1 Basic distribution.....	34
2.3.2 Optionality	36
2.3.3 Clefts.....	37
2.3.4 Prepositions.....	38
2.3.5 Arguments: Word order	39
2.3.6 Clefts again.....	41
2.3.7 Prepositions again	42
2.3.8 A prediction.....	43
2.4 Dative verbs.....	44
3 Pearson (1998a).....	48
4 A unified analysis of passive.....	54
4.1 Structure.....	54
4.2 Semantics.....	56
4.3 Change of location.....	57
5 Discussion	59
5.1 Case and transitivity.....	59
5.2 Constituency.....	63
5.3 Base generation vs. movement	66
5.4 Cross-linguistic evidence	68
5.5.1 Instrumental advancement.....	69

5.5.2	Locative alternation.....	70
5.5.3	Applicative.....	71
6	Aspect.....	73
6.1	Kimaragang Dusun.....	74
6.2	Malagasy.....	76
6.2.1	Locative alternation.....	77
6.2.2	Dative shift.....	79
6.2.3	On the importance of roots.....	80
6.2.4	Further data.....	82
7	Conclusion.....	85
7.1	Passive.....	86
7.2	[Spec, v2P].....	86
7.3	Lexical semantics.....	89
7.4	TT vs. CT.....	90
Chapter 3: Circumstantial Topic.....		91
1	Introduction.....	91
2	CT clauses.....	94
2.1	The core data.....	94
2.2	Targets.....	96
2.3	Subjects.....	99
2.4	Clefts.....	100
2.4.1	AT clefts.....	103
2.4.2	CT clefts.....	107
2.5	A note on CPs.....	108
2.6	Where are we?.....	110
3	CT= promotion of adjuncts.....	111
3.1	Theta-agreement.....	111
3.2	Adjuncts vs. arguments.....	113
3.3	PP arguments.....	116
3.4	ECTM.....	117
3.5	Theory.....	117
4	CT = preposition incorporation.....	118
4.1	Guilfoyle, Hung and Travis.....	118
4.2	Applicatives.....	119
4.3	Prepositions.....	122
5	Analysis.....	124
6	ECTM.....	128
6.1	Partitives in Malagasy.....	128
6.1.1	Periphrastic partitives.....	129
6.1.2	Subject position.....	130
6.1.3	Existentials.....	130
6.1.4	Exceptional Circumstantial Topic Marking.....	131
6.2	ECTM: An analysis.....	132
6.3	Data.....	134
6.3.1	Prepositions and partitivity.....	134
6.3.2	Theme or not a theme?.....	135
6.4	Floating quantifiers: a problem?.....	138
6.5	Malagasy madness?.....	141

6.5.1	Tagalog.....	142
6.5.2	Inibaloi.....	142
6.5.3	Partitive Case	143
6.6	Conclusion	144
7	Circumstantial Topic: Other languages.....	145
8	Conclusion.....	146
Chapter 4: The left periphery		148
1	Introduction.....	148
2	The left periphery.....	148
2.1	Topic and focus.....	150
2.2	Topic>focus.....	151
2.3	dia topics.....	152
2.4	Focus.....	157
2.5	The bodyguard.....	159
2.6	Malagasy clause-structure	161
3	The structure of clefts.....	163
3.1	It-clefts	163
3.2	Pseudo-clefts.....	167
3.3	Pivot=predicate	169
3.4	Presuppositional clause=headless relative	172
3.5	Interpretation	175
3.6	Interlude: ve.....	176
4	Cleft as focus	181
5	Multiple clefts	185
5.1	Coordination	188
5.2	Amalgamation.....	189
5.3	Multiple specs	193
5.3.1	Slavic multiple wh-fronting.....	193
5.3.2	Bodyguard ≠ focus	196
5.3.3	Bodyguard = topic.....	199
5.4	Where are we?	204
5.5	Speculations	205
5.6	Wh- bodyguard.....	207
5.6.1	Order	208
5.6.2	D-linking	210
6	Conclusion.....	211
Chapter 5: Conclusion		213
Appendix		216
References		222

Chapter 1: Introduction

1 Voice

One of the most striking properties of western Austronesian languages is their verbal morphology. Certain morphemes appear to encode the relation that the subject NP bears to the rest of the clause.¹ This can be observed in the Malagasy example in (1), where the voice morphology differs depending on which DP appears in the subject position.

- (1) a. Nanapaka ity hazo ity tamin'ny antsy i Sahondra.
pst.AT.cut t his tree this pst.P.gen.det knife Sahondra
'Sahondra cut this tree with the knife.'
- b. Notapahin'i Sahondra tamin'ny antsy ity hazo ity.
pst.TT.cut.gen.Sahondra pst.P.gen.det knife this tree this
'This tree was cut by Sahondra with the knife.'
- c. Nanapahan'i Sahondra ity hazo ity ny antsy.
pst.CT.cut.gen.Sahondra this tree this det knife
'The knife was used by Sahondra to cut the tree.'

In (1a), the agent is the subject and the verb bears ActorTopic (AT) marking. In (1b), it is the theme that appears in the subject position and the verb is marked with ThemeTopic (TT). Finally, in (1c) the instrument is the subject when the verb takes CircumstantialTopic (CT) morphology. I will refer to this morphology as the voice system. Due to its prevalence in this language family, the western Austronesian voice system has received a certain amount of attention by grammarians and linguists alike.

The question arises as to the proper treatment of voice. Is the morphology sensitive to theta-roles, category, position, function, or something else? Before addressing the voice system of Malagasy, I will begin with some background on voice and passive. This is a topic that has long captured the interest of linguists. Since it is not my goal to give a

¹ Throughout I will mark the (matrix) grammatical subject with a dotted underline. Other constituents may be marked with brackets or boldface.

comprehensive literature review, which would take us too far afield, I will provide but a brief overview of the issues before turning to the Malagasy data.

As a starting point, let us consider past treatments of the active-passive alternation. Many natural languages display alternations similar to the ones in (2) and (3).

- | | | | | |
|-----|----|------------------------|----|--------------------------------|
| (2) | a. | Felix cut the bread. | b. | The bread was cut by Felix. |
| (3) | a. | Félix a coupé le pain. | b. | Le pain a été coupé par Félix. |

The two active sentences in (a) express basically the same meaning as the passive ones in (b). Nevertheless, the surface forms are quite different: in (2a) and (3a), the agent is the subject; in (2b) and (3b), the theme is the subject. Much syntactic research has centered on formalizing the relation between the active and the passive.

Drawing on data from a range of languages, Relational Grammar characterizes passive with two universal properties (Perlmutter and Postal (1977)):

- | | | |
|-----|----|--|
| (4) | a. | A direct object of an active clause is the (superficial) subject of the ‘corresponding’ passive. |
| | b. | The subject of an active clause is neither the (superficial) subject nor the (superficial) direct object of the ‘corresponding’ passive. |

Due to other laws of grammar (e.g. the Stratal Uniqueness Law), the active subject is demoted in a passive clause, often surfacing as a “chômeur” (oblique). Thus passive has a dual nature: the promotion of the object to subject and the demotion of the subject.

A standard Government-Binding analysis claims that the theme moves into the subject position because the passive verb can no longer assign accusative Case (e.g. Chomsky (1981)). Furthermore, the passive verb lacks the ability to project an external argument. (See Baker, Johnson and Roberts (1989) for a slightly different GB account.) The subject of the active verb may optionally appear as an oblique adjunct. These two properties are related in what is known as Burzio’s Generalization (Burzio (1986)):

- (5) a. A verb which lacks an external argument fails to assign accusative Case.
b. A verb which fails to assign accusative Case fails to theta-mark an external argument.

As in RG, GB passive involves two components, here linked to Case and theta-role assignment.

There are some disadvantages to the above characterizations. For example, both RG and GB treat passive as consisting of two-parts. But do these two parts always correlate? There are languages where promotion of the logical object to subject does not lead to demotion of the logical subject (see section 3.2 on Malagasy). There are also languages where the demotion of the logical subject does not coincide with the promotion of a logical object (e.g. Itelmen (Jonathan Bobaljik, p.c.) and impersonal passives in general (Comrie (1977))). Therefore, (5a) and (5b) are arguably independent of each other, as are the two parts of the RG definition of passive. Due to these considerations, (4) and (5) have been modified by subsequent research in both the RG and GB literature.

Another limitation of both the RG and the GB approaches is that they only discuss the active-passive alternation. Some languages exhibit more than the one-way distinction between active and passive illustrated in (2) and (3).² Specifically, passive is defined as a transformation that affects arguments of the verb (objects in RG or accusative Case-marked NPs in GB). Austronesian voice alternations, however, are not limited to passive and hence often involve not only arguments, but also adjuncts. Malagasy is typical of such a system and is commonly assumed to have a three-valued voice distinction: active, passive, circumstantial (sometimes referred to as “relative”).

In this thesis, I will show that not only does Malagasy enjoy more than the active-passive alternation, it also benefits from distinct types of passive for different internal arguments. For the most part, I will ignore the active sentences, concentrating on the passive and circumstantial and on

² Perlmutter and Postal (1977) fully acknowledge this limitation. Bell (1976) provides an RG analysis of Cebuano, which displays voice alternations similar to Malagasy. See also Gerds (1988) on Ilokano. Chomsky (1981) also points out the variation in passive-like constructions cross-linguistically. For an overview of this variation, see Shibatani (1985).

the NPs that appear in the subject position of these clauses. Clearly, a proper characterization of voice will depend on a careful investigation of each alternation.

2 Voice in Austronesian

Let us now turn to existing analyses of voice in western Austronesian. These analyses will be discussed in more detail in chapters 2 and 3. Here, I simply introduce the basic principles of each.

2.1 Structure

Guilfoyle, Hung and Travis (1992) (henceforth GHT) propose a purely structural account of voice alternations. Consider the voice paradigm in (1), repeated in (6).

- (6) a. Nanapaka ity hazo ity tamin'ny antsy i Sahondra.
 pst.AT.cut this tree this pst.P.gen.det knife Sahondra
 'Sahondra cut this tree with the knife.'
- b. Notapahin'i Sahondra tamin'ny antsy ity hazo ity.
 pst.TT.cut.gen.Sahondra pst.P.gen.det knife this tree this
 'This tree was cut by Sahondra with the knife.'
- c. Nanapahan'i Sahondra ity hazo ity ny antsy.
 pst.CT.cut.gen.Sahondra this tree this det knife
 'The knife was used by Sahondra to cut the tree.'

For GHT, the active morpheme assigns accusative case to the direct object and the passive morpheme assigns genitive to the agent in [Spec, VP]. In (6a), therefore, the agent does not receive Case and must raise to [Spec, IP] for nominative. In (6b), on the other hand, the theme is not Case-marked in its base position and raises to the subject position. One advantage of this proposal is that it neatly captures certain properties of CT.

As noted by GHT and others, in one respect, the circumstantial construction resembles both the active (AT) and the passive (TT). Like in the active, a transitive CT verb may take a direct object marked with accusative Case. Like in the passive, the agent appears in the genitive.

These two properties are illustrated in (6c): *Sahondra* bears genitive Case; *ity hazo ity* ‘this tree’ is in (unmarked) accusative. This combination of AT and TT is also present to some degree in the morphology of CT: the verb bears both an active prefix and a passive suffix. (Unlike in the passive, however, this suffix is invariably *-ana* and never *-ina*.) The morphology of the forms in (6) is given in (7).

- (7)
- | | | | | |
|----|-----|---------------|---|-----------|
| a. | AT: | m-an-tapaka | ⇒ | manapaka |
| | | pres-AT-cut | | |
| b. | TT: | tapaka-ina | ⇒ | tapahina |
| | | cut-Vna | | |
| c. | CT: | an-tapaka-ana | ⇒ | anapahana |
| | | AT-cut-ana | | |

The above parallels have led some researchers to claim that the circumstantial indeed combines the active and the passive in the syntactic structure. This is true of both traditional grammars (e.g. Rajemisa-Raolison (1966)) and in the Principles and Parameters literature (e.g. GHT). Recall that GHT state that active morphology assigns accusative Case to the theme, while passive morphology licenses genitive Case for the agent. Putting the two together creates CT, which is characterized by the availability of both accusative and genitive. Furthermore, GHT suggest that CT involves preposition incorporation, along the lines of Baker (1988). Following preposition incorporation, the object of the preposition (*ny antsy* ‘the knife’ in (6c)) no longer receives Case and must raise to the matrix subject position for nominative. It is via P-incorporation that GHT integrate CT into the traditional Case analysis of voice.

2.2 Semantics

Keenan (in press) proposes a semantic analysis of Malagasy voice. Simplifying somewhat, voice morphology denotes a function. For CT, for example, the function is true iff the nominal in subject position can be related to the predicate via some preposition. In other words, while Keenan argues against preposition incorporation in the syntax, the

prepositional meaning is encoded in the semantics of the CT morphology. In this way, both Keenan and GHT base their analyses of CT on the link between CT and prepositions.

2.3 *Theta roles*

Other linguists have focussed on the link between thematic roles and voice morphemes. At first glance, the voice system in Malagasy and many other western Austronesian languages appears to encode the theta role of the NP in subject position.

- (8) a. Actor Topic (AT): agent subject
- b. Theme Topic (TT): theme subject
- c. Circumstantial Topic (CT): oblique subject

Due to the correlation between voice marking and thematic roles, some researchers have proposed a system of “theta agreement” (e.g. Sityar (in press)):³

- (9) The nominal features of VoiceP must agree with the thematic features of the topic.

The voice morphology on the verb is therefore a special form of subject agreement. Following verb raising, the subject NP and the verb are in a local, spec-head relation which mediates agreement. In support of this approach, current research suggests that theta-roles are in fact features that must be checked, similar to Case (Boskovic (1994); Hornstein (1999)). With theta-roles as features, theta-agreement is parallel to other types of agreement, for example number and person.

Summing up, we see that the Malagasy voice alternations can be viewed from a wide range of perspectives. One of the goals of chapters 2 and 3 is to assess these different analyses. Although I argue for a structural analysis of voice similar to GHT, I offer some modifications and refinements to their proposal. Before delving into the voice data in chapter 2, I will provide some background on Malagasy syntax and

³ Although Sityar’s proposal is for Cebuano, it can easily be adapted to any language with similar voice alternations. She refers to as “topic” the position that I am calling “subject”.

morphology.

3 Malagasy

The object of study in this dissertation is the syntax of Malagasy. Malagasy is a western Austronesian language spoken on the island Madagascar by over 12 million people. Dahl (1951) suggests that the closest relatives are the S.E. Barito languages, such as Maanjan in Kalimantan (Borneo). There are various dialects in Madagascar; all the data cited are from the Merina dialect of the capital and central plateau region.⁴ Unless otherwise indicated, the data in this dissertation were collected from native speaker consultants in Madagascar in 1995 and in Montreal from 1993 to 1999. Malagasy data from other sources have been checked with the Montreal consultants. All instances of disagreement among consultants have been noted in the text.

The grammar of Malagasy has been studied in the Western tradition since the arrival of missionaries in the last century. A Malagasy-French dictionary was published in 1888 (Abinal and Malzac (1888)) and remains a standard reference. Since then, several grammars written by Malagasy linguists have appeared (e.g. Rahajarizafy (1960); Rajemisa-Raolison (1966); Rajaona (1972)). Due to ties with France, current linguistic research in Madagascar adopts the transformational theories of Gross (1975); Harris (1976). Several theses have appeared on different aspects of clause structure (e.g. verbal complementation (Rabenilaina (1985)), adjectives (Rahalalaoherivony (1995)), temporal adverbs (Raharinirina-Rabaovololona (1991))). Thus Malagasy syntax has been well-documented for over a century.

In this section, I will give some background on Malagasy clause-structure and morphology which will be helpful to the reader unfamiliar with this language. In the main chapters of this dissertation, I will therefore refer back to the introduction for certain points not directly related to the analysis at hand. The following is nevertheless not meant to be a comprehensive overview of Malagasy grammar. Instead, I concentrate on structures that will be relevant to the main content. For a detailed discussion of Malagasy morphology, I refer the reader to Keenan

⁴ One of my consultants speaks the Betsileo dialect, which is also from the central plateau region and is very similar to Merina. All data have been verified across consultants and differences in judgements are mentioned.

and Polinsky (1996). References to works on Malagasy syntax will be given throughout.

3.1 Word order

Malagasy is a VOS language with clear evidence for a constituent break between the subject and the rest of the clause, as will be shown below. For simplicity, I refer to this constituent as VP, although it may be some larger XP.⁵ Importantly, the subject is VP-external. Examples of basic Malagasy sentences are given in (10), where the VP is indicated by bracketing.⁶

- (10) a. [Dokotera] i Bakoly.
 doctor Bakoly
 ‘Bakoly is a doctor.’
- b. [Hendry] ny ankizy.
 wise det child
 ‘The children are well-behaved.’
- c. [Mividy mofo ho an-dRabe] ity vehivavy ity.
 AT.buy bread for acc-Rabe this woman this
 ‘This woman buys bread for Rabe.’
- d. [Tany an-tsena] izy.
 pst.there at-market 3sg(nom)
 ‘She was at the market.’

In each case, whether the predicate is nominal, adjectival, verbal or other and despite the lack of a copula, I assume there to be a matrix VP as indicated. All categories are generally head-initial. Thus determiners precede head nouns as in (10b) and prepositions are initial in PP (10d). Somewhat unusually, demonstratives frame NPs, as in (10c). For an analysis of DP structure in Malagasy, see Zribi-Hertz and Mbolatianavalona (1999).

⁵ Keenan (in press) refers to this constituent as PredP.

⁶ All proper names in Malagasy include a determiner, *i* (10a), *Ra* (10c) or *ry* for plural proper names.

Keenan (1976) provides several tests that support the division between VP and the subject, indicated by the brackets in (10). For example, the question particle *ve* and the negative polarity item *intsony* ‘no longer’ appear between the VP and the subject.⁷

- (11) a. Mividy mofo ho an’ny ankizy **ve** i_Bakoly?
 AT.buy bread for acc’det child **Q** Bakoly
 ‘Does Bakoly buy bread for the children?’
- b. Tsy mividy mofo ho an’ny ankizy **intsony** i_Bakoly.
 neg AT.buy bread for acc’det child **NPI** Bakoly
 ‘Bakoly no longer buys bread for the children’

Malagasy thus appears to be a highly configurational language, unlike some of the Philippine languages, for example, which have freer word order.

As well as appearing in a well-defined structural position, the subject in Malagasy is subject to a definiteness/specificity restriction. Indefinite subjects are ungrammatical, as illustrated in (12) (cf. (10b)).⁸

- (12) * Mihira ankizy.
 AT.sing child
 ‘Some children are singing.’ or ‘A child is singing.’

This restriction on the subject position will become important in the discussion of CT in chapter 3.

In order to account for the VOS word order, Guilfoyle, Hung and Travis (1992) propose the following structure, where [Spec, IP] is to the right.

⁷ In chapter 4, section 3.6, I show that in fact *ve* is a second position clitic.

⁸ As indicated by the translations of (12), there is no overt number marking on common nouns. Examples such as (12) are therefore typically ambiguous. To simplify the text, I will give a single translation.

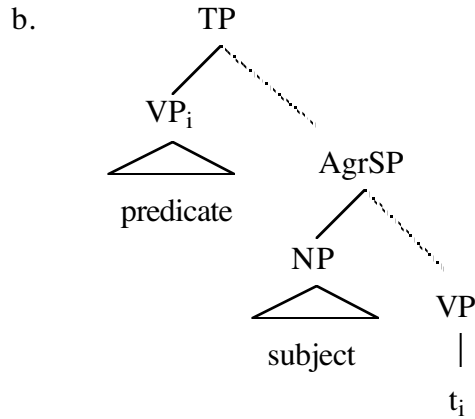

For the most part, I adopt the GHT analysis of Malagasy. In certain cases, however, I discuss the implications for a predicate-fronting analysis (see in particular chapter 4). I also remain agnostic as the articulated structure of IP (Pollock (1989)), as it does not bear on the issues in this thesis.

As mentioned above, the VOS order is fixed; Malagasy does not have the free word order commonly available in the Philippine and Malay languages. In certain contrastive contexts, however, SVO is possible.

- (15) Ny mpianatra mamaky teny, ny mpampianatra mihaino.
 det student AT.read word det teacher AT.listen
 ‘The students read aloud, the teacher listens.’

The subject can also be fronted for topicalization or clefting, to be discussed in chapter 4.

- (16) a. [Ny mpianatra] dia mamaky teny.
 det student top AT.read word
 ‘As for the students, they are reading.’
- b. [Ny mpianatra] no mamaky teny.
 det student foc AT.read word
 ‘It’s the students who are reading.’

Other subject-initial “clauses” are given below. (17a) is an example of a temporal adjunct, headed by the preposition *amin’*. (17b) illustrates the clausal complement to a perception verb. (17c), finally, is an instance of

raising to object.

- (17) a. Nalahelo i Sahondra [tamin-dRasoan nanoroka an-dRabe].
 pst.sad Sahondra pst.P.gen.Rasoan pst.AT.kiss acc-Rabe
 ‘Sahondra was sad when Rasoan kissed Rabe.’
- b. Mijery [ny namany mikapoka ny alika] i Sahondra.
 AT.watch det friend.3(gen) AT.beat det dog Sahondra
 ‘Sahondra watches her friends beat the dog.’
- c. Mihevitra [an-dRakoto ho hanasa lamba] Rabe.
 AT.think acc-Rakoto C fut.AT.wash cloth Rabe
 ‘Rabe thinks that Rakoto will wash clothes.’

In all the above cases, the bracketed constituent appears to be clausal rather than nominal in nature (e.g. verbal rather than nominal morphology on the verb). Clearly, the structure of the clausal complements in (17) is debatable, but on the surface all exhibit SVO order. I will not address these issues in this thesis.

3.2 Voice

In section 1, I outlined some properties of the Malagasy voice system. The examples in (18) repeat the standard voice alternation.

- (18) a. Nanapaka ity hazo ity tamin’ny antsy i Sahondra.
 pst.AT.cut this tree this pst.P.gen.det knife Sahondra
 ‘Sahondra cut this tree with the knife.’
- b. Notapahin’i Sahondra tamin’ny antsy ity hazo ity.
 pst.TT.cut.gen.Sahondra pst.P.gen.det knife this tree this
 ‘This tree was cut by Sahondra with the knife.’
- c. Nanapahan’i Sahondra ity hazo ity ny antsy.
 pst.CT.cut.gen.Sahondra this tree this det knife
 ‘The knife was used by Sahondra to cut the tree.’

In an active (AT) clause, the agent is the subject, while in the passive (TT) and circumstantial (CT) constructions, the agent surfaces immediately to the right of the verb, bearing genitive case. GHT take advantage of the VP-internal subject hypothesis to account for the position of the agent. They claim that in TT and CT, the agent is licensed by genitive case in [Spec, VP]. (In AT, genitive is not available and the agent raises to [Spec, IP].) The difference between English and Malagasy therefore lies in the fact that the passive agent is not demoted to an oblique in the latter. In [Spec, VP], the agent remains syntactically “active”.⁹ Chapters 2 and 3 discuss TT and CT, respectively, with a focus on characterizing the elements that are promoted to subject.

3.3 Morphology

Malagasy is predominantly a prefixing language. Suffixing is nevertheless common, with a few infixes and circumfixes. Much of the morphological system is verb-based, as exemplified by the voice markers above. Active verbs are almost all derived from roots, which are predominantly nominal or adjectival. There are some verbal roots, but these are almost all unaccusative.

- (19) a. tonga ‘arrive’
b. avy ‘come’

Other active verbs take one or more prefixes. The most common are *an-* and *i-*. Both derive intransitive and transitive verbs, as seen in (20a,b). When a single root has an intransitive and a transitive form, *i-* marks the former and *an-* the latter (20c,d). Under *an-* prefixation, the nasal of the prefix “fuses” with the initial consonant of the root, as in (20a,c); see Paul (1996a) for details. In addition, the verb is marked with a temporal prefix: *m-* (present), *n-* (past), *h-* (future).¹⁰

⁹ Standard evidence against the obliqueness of genitive agents includes binding and control. Since binding and control can be defined at D-structure (or argument structure; see e.g. Wechsler and Arka (1998) on Balinese), this is not a knock-down argument against demotion. Note, however, that the genitive agent occupies a fixed position in the clause, unlike obliques, which tend to display less restricted distribution.

¹⁰ The past and future tense prefixes also occur in non-active voices, but the present tense *m-* is not.

- (20) a. m+an+hovitra = mangovitra ‘(to) shiver’
 b. m+i+kapoka = mikapoka ‘(to) beat’
 c. m+an+sasa = manasa ‘(to) wash’ (transitive)
 d. m+i+sasa = misasa ‘(to) wash’ (intransitive)

Other active prefixes are listed below; both *amp* and *if* are affixed onto active verbs, while *aha* attaches directly to a root. All take the temporal affixes.

- (21) a. amp- (causative)
 m+amp+an+sasa = mampanasa ‘to make s.o. wash s.t.’
 b. aha- (abilitative/causative)
 m+aha+sasa = mahasasa ‘to be able to wash’
 c. if- (reciprocal)
 m+if+an+sasa = mifanasa ‘to wash each other’

For discussion of the causative, see Randriamasimanana (1986); Andriamierenana (1996); Travis (in press). Phillips (in press) provides a thorough analysis of *aha-*.

The passive and the circumstantial voices will be the object of chapters 2 and 3, so I do not discuss them in detail here. As mentioned above, the agent in TT and CT clauses appears marked with genitive case. Genitive case is widely present in Malagasy, marking passive agents, possessors as well as the complements of some prepositions and adjectives; see Paul (1996c) for a range of examples. Genitive involves insertion of a nasal consonant between the verb and the NP. Moreover, the final *-na*, *-ka*, or *-tra* of the verb is dropped. These morpho-phonological processes are illustrated in (22); (22a) shows that /n/+/r/ = [ndr].¹¹

- (22) a. sasa+ana+N+Rakoto = sasan-dRakoto
 wash-Vna-gen-R
 ‘washed by Rakoto’

¹¹ To be precise, the sequence *ndr* is a single prenasalized segment [ndr].

Chapter 1

- b. toro+N+ny olona = toron'ny olona
shown-gen-det people
'shown by the people'

The other cases, accusative and nominative, are not marked on most nouns. Thus only word order distinguishes (23a) from (23b).

- (23) a. Nahita ny lehilahy ny vehivavy.
pst.AT.see det man det woman
'The woman saw the man.'

- b. Nahita ny vehivavy ny lehilahy.
pst.AT.see det woman det man
'The man saw the woman.'

Accusative case does mark proper names (24a), interrogative pronouns (24b) and demonstratives (24c).

- (24) a. Nahita an-dRabe ny vehivavy.
pst.AT.see acc-Rabe det woman
'The woman saw Rabe.'

- b. Nahita an'iza ny lehilahy?
pst.AT.see acc'who det man
'Who did the man see?'

- c. Nahita an'ity vehivavy ity ny lehilahy.
pst.AT.see acc'this woman this det man
'The man saw this woman.'

Otherwise, the only consistent case morphology shows up in the pronominal system.

(25)

	nominative	accusative	genitive
1st singular	aho	ahy	-ko/-o
2nd singular	ianao	anao	-nao/-ao
3rd singular	izy	azy	-ny
1st plural incl	isika	antsika	-ntsika/-tsika
1st plural excl	izahay	anay	-nay/-ay
2nd plural	ianareo	anareo	-nareo/-areo
3rd plural ¹²	izy (ireo)	azy (ireo)	-ny/izy ireo

4 Theoretical assumptions

This thesis is written in the Principles and Parameters framework of Chomsky (1981). NP movement is motivated for Case assignment (under government or spec-head agreement). For the most part, however, I do not discuss the details of this movement. Instead, I focus on the phrase structure of Malagasy.

This thesis also draws on certain assumptions about connections between lexical items and syntactic structure. In particular, verbs are associated with lexical conceptual structure, which determines how the arguments are projected into the syntax.

5 Organization of the thesis

This chapter has provided an introduction to Malagasy syntax as well as setting up the question of voice alternations. Let me admit at this point that this thesis has a clear empirical bias. Since my main goal is to arrive at a proper characterization of voice in Malagasy, I focus almost exclusively on Malagasy. Nevertheless, I also draw on data from other languages, both from within the same family (e.g. Tagalog) and from unrelated languages (e.g. Japanese). I show that many of the phenomena that I discuss are not unique to Malagasy. Due to this “narrow” focus on a single language, I address a broad range of topics. As a result, many

¹² The third person pronouns are ambiguous between singular and plural. The addition of *ireo* forces a plural reading.

issues I will mention only in passing and leave for further research. The overarching goal is to gain insight into the “genius” of Malagasy.

In chapter 2, I address the nature of passive in Malagasy. I look at two different passive affixes and argue that each affix promotes arguments from different structural positions. Moreover, I provide evidence in favour of a position, [Spec, v2P], that hosts a special class of arguments, “displaced themes” or “locata”. In this way, I use voice morphology as a probe into the syntactic structure associated with three argument verbs.

The analysis of passive in chapter 2 leads directly into the investigation of CT in chapter 3. While passive promotes DP arguments to subject, CT is less easily defined. I argue that CT is a kind of “elsewhere” voice that promotes anything but structurally Case-marked DPs. The discussion covers the nature of adjuncts and PPs in Malagasy, as these have been the focus of previous analyses of CT. Taken together, the analyses in chapters 2 and 3 indicate that voice morphology can have distinct “functions”, even within a single language. For example, I show that one passive promotes DP arguments from a particular position ([Spec, v2P]) and another passive promotes DP arguments from a particular domain (the lower VP). CT, on the other hand, promotes elements from a wide range of positions.

Chapters 2 and 3 focus on the base position of arguments (and adjuncts) as well as the phrase structure within the verbal projection. In chapter 4, I examine the positions of arguments and adjuncts when they appear in the “left periphery” of the clause. Drawing on data from topic and focus constructions, I propose an articulated CP, along the lines of Rizzi (1997). The core of chapter 4 is devoted to the cleft construction, due to its relevance in both chapter 2 and 3 as a test for the argument-adjunct distinction. Although chapter 4 does not address precisely the same questions as chapters 2 and 3, it illustrates one way in which the A-bar system (extraction) interacts with the A system (voice) in Malagasy.

Chapter 2: Theme Topic

1 Introduction

This chapter focusses on the connections between argument structure and phrase structure. In order to probe the syntactic structure of the clause, I will look at the verbal morphology of voice alternations. In chapter 1, I pointed out that Malagasy has a basic three-way voice distinction: AT, TT and CT. I will now look more closely at TT, which in fact encompasses a range of passive-like transformations. By analyzing two distinct passive formations which promote different internal arguments, I will investigate the internal structure of the verbal projection. In turn, the syntactic structure provides an insight into argument structure.

In particular, I will argue for an additional verbal projection (v2P) between the base positions of agent and theme. Certain DPs may be base generated in [Spec, v2P]. The use of this position is lexically restrained, however, and only available with a special class of verbs and a restricted class of DPs. I will provide an informal characterization of the semantics of the verbs and the DPs involved. Ultimately, a proper lexical semantic study will elucidate this issue. For the purposes of this chapter, I will concentrate on the syntactic structure. The data I will consider include alternations that have often been analyzed as involving some form of syntactic movement or “promotion”, for example dative shift and the locative alternation. Due to the restrictive nature of these alternations in Malagasy, I will argue that there is no movement, per se. Instead, verbs that encode a change of location allow certain DPs (roughly, “displaced themes” or “locata”) to appear in [Spec, v2P]. Crucial evidence will come from passive morphology. One passive affix (*a-*) promotes DPs in [Spec, v2P] to subject. Another passive affix (*-Vna*) promotes DPs from the lower VP. The basic VP structure is given below.

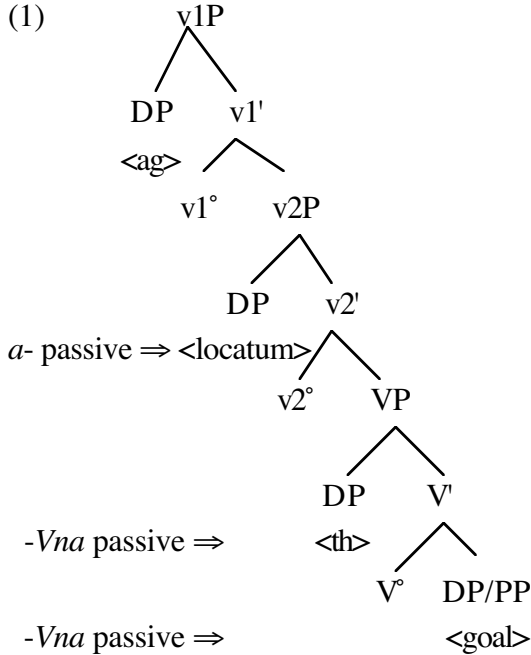

A secondary goal will be to contrast passive with circumstantial topic in chapter 3.

Section 2 provides an overview of the data to be considered in this chapter. In particular, I will investigate verbs that show an alternation between two different passive affixes, *a-* and *-Vna*. In section 3, I discuss an analysis of the data in terms of lexical semantics. I show some limitations of this approach and propose a different analysis in section 4. Section 5 is devoted to further discussion of the data. Due to the importance of aspect in word order alternations, I consider the aspectual properties of the Malagasy verbs in section 6. I highlight the importance of the roots underlying these verbs in determining affectedness relations. Section 7 concludes the chapter.

2 Passive in Malagasy

The introduction to voice in Malagasy in chapter 1 presented a simplified version of the range of data. Each “voice” requires separate discussion and explication. The differences between circumstantial and passive will be crucial to my analysis, both in this chapter and the next.

Before beginning, however, it is necessary to answer the question: what is passive? This is, as mentioned in chapter 1, a thorny issue and the subject of much linguistic research. For the purposes of this chapter, I will characterize passive as a clause where an internal argument of a two (or

more) argument verb appears as the grammatical subject. The external argument is either not present or surfaces in some non-subject, non-object position.¹ As discussed in chapter 1, in Malagasy the external argument is not realized as an oblique, unlike English. In other words, the passive agent remains syntactically “active”, although it is optional. The lack of demotion to *chômeur* of passive agents in Austronesian has long been recognized as one of the distinguishing properties of voice alternations in these languages.

Note that my use of the term “passive” is not without controversy in the Austronesian literature. The lack of demotion mentioned above has led some researchers to conclude that what I am calling “passive” is in fact an ergative construction (e.g. Gerdtz (1988) on Ilokano; Wechsler and Arka (1998) on Balinese). Moreover, some Austronesian languages have two “passive” constructions: one that is like English and involves an oblique agent and one that is like Malagasy (e.g. Indonesian (Chung (1976b)) and Balinese (Wechsler and Arka (1998))). My very informal definition of passive covers both types.

In fact, I do not consider Malagasy to be an ergative language (and I am not aware of any ergative analyses of Malagasy). The subject of a single argument verb and the subject of what appears to be a transitive verb are both marked with the same Case (nominative). Note that in the examples in (2), the verbal morphology is the same (*man-*, glossed as AT).

- (2) a. Manasa lamba *izy*.
 AT.wash cloth 3(nom)
 ‘She is washing clothes.’
- b. Mandihy *izy*.
 AT.dance 3(nom)
 ‘She is dancing.’

¹ In fact, the genitive agent in Malagasy (and other Austronesian languages) bears some resemblance to (indefinite) objects: it surfaces right-adjacent to the verb and no elements can intervene between the verb and the agent. However, in Malagasy at least, genitive agents and accusative objects have very different phonological properties. For example, as mentioned in chapter 1, section 3.3, genitive involves pre-nasalization, not present in bare NP accusative. Moreover, as also illustrated in the same section, a distinct set of pronouns is available for genitive and accusative.

- c. Mangovitra *izy*.
AT.tremble 3(nom)
'She is shivering.'

Under an ergative analysis, AT is a kind of antipassive. Note, however, that the logical object in (2b) is not marked as an oblique. Historically, the lack of demotion of the agent to oblique in what I am calling "passive" is in part related to ergativity (see Chung (1978)). In other words, I assume there to be some influence on Malagasy from ergative languages in this family. Austronesian languages exhibit ergative characteristics to varying degrees, creating a continuum of ergativity. Maclachlan (1996), for example, argues that Tagalog has both nominative-accusative and ergative-absolutive properties and provides a "hybrid" analysis. Finally, I believe that the ergativity issue is tangential to the data discussed in this chapter. Whether one adopts a passive or an ergative analysis of Malagasy, there remains the question of how to account for which arguments appear as the nominative/absolutive DP. I henceforth ignore the ergativity debate and use the term "passive" as defined.

I begin with a brief description of passive formation in Malagasy and then examine two different affixes in detail. I will show that these affixes are passive as defined above. Problematic for this claim are apparent adjuncts (e.g. instruments) that can passivize to subject position with the *a-* prefix. If these examples truly involve adjuncts, then, by definition, the *a-* prefix cannot be passive. I will provide evidence, however, that in these cases, the instrument has been base generated as an internal DP argument of the verb. Hence the *a-* passive is always from an argument position. Moreover, passive promotes DP and not PP arguments. I conclude with a unified analysis of passive constructions that posits a special position for certain base generated elements. The analysis of passive will provide a point of departure for the discussion of circumstantial topic in the following chapter.

2.1 *Passive formation*

There are essentially four types of passive in Malagasy: roots, *voa/tafa* passives, *-Vna* passives and *a-* passives. I provide here a brief overview of all four, but for the remainder of this chapter, I focus on the last two.

Many bare roots correspond to passives: an underlying theme

appears in the subject position. The agent may appear as a genitive DP, which forms a phonological unit with the verb, as in (3b,c).

- (3) a. Hita ny.sary.
 seen det picture
 ‘The picture is seen.’
- b. Hitako izy.
 seen.1sg(gen) 3(nom)
 ‘She is seen by me.’
- c. Hitan-dRamatoa aho.
 seen.gen.Ramatoa 1sg(nom)
 ‘I am seen by Ramatoa.’

Root passives are the most common passive forms in text counts (Manorohanta (1998)).

The three other passives involve affixation. The prefixes *voa* and *tafa* attach directly to a root to form a passive or inchoative verb.

- (4) a. Voavory ny.mpiasa.
 voa.gather det worker
 ‘The workers were gathered.’
- b. Tafavory ny.mpiasa.
 tafa.gather det worker
 ‘The workers gather.’

Both affixes have additional aspectual import and I refer the reader to Travis (1996) for some discussion. Roughly, *voa* is available for transitives and *tafa* is for intransitives. According to Rahajarizafy (1960), roots and *voa/tafa* passives all express a resulting end state and thus form a natural class (telic). Thus *voa/tafa* passives contrast with *a-/-Vna* passives, as the latter are used to promote different arguments of the verb, as we will see below.

Turning now to the passives that will be the focus of this chapter, most

roots take the *-ina* or *-ana* suffix to form the passive.² Since the choice between *-ina* and *-ana* is lexicalized, I will refer to the two as *-Vna*.^{3,4} In general, the theme is promoted to subject.

- (5) a. laza + ina = lazaina ‘said’
 b. sasa + ana = sasana ‘washed’

-Vna is the most commonly occurring passive affix (as opposed to the affixless roots mentioned above) in texts (Manorohanta (1998)). Finally, there is the *a-* prefix, which also attaches directly to roots.

- (6) a. a-*tao* ‘done’
 b. a-*didy* ‘cut’

In contrast to *voa/tafa* passives, neither *-Vna* nor *a-* passive are telic (see section 6 for some discussion of telicity in Malagasy.) In what follows, I will characterize the syntactic conditions under which the *-Vna* suffix alternates with the *a-* passive.

2.2 *a-* passive vs. *-Vna* passive: basic distribution

Verbs fall into two main classes with respect to passive affixes: those that have only one of the passives and those that have both.

2.2.1 *One passive*

In the first group we have the following verbs which take the *a-* prefix to

² A small number of verbs keep the active prefix in the passive. Examples are in (i).

(i)

root	active verb	meaning	TT	CT
halatra	mangalatra	‘to steal’	angalarina	angalarana
voatra	mamboatra	‘to prepare’	amboarina	amboarana

This is also true for causatives in general.

(ii)

verb	meaning	TT	CT
mampiasa	‘to make work’	ampiasaina	ampiasana
mankarary	‘to make sick’	ankararina	ankarariana

³ Some roots may take both *-ina* and *-ana*, with a slight difference in meaning. These roots are very rare, however, and the distinction in meaning is disappearing. My consultants either reject one form or consider the two to be synonymous.

⁴ In many cases, an “epenthetic” consonant is inserted between the root and the suffix. See Erwin (1996) for arguments that this consonant is present in the underlying representation of the root and not in the suffix.

promote a theme to subject.⁵

(7)

root	active verb	meaning	subject of <i>a-</i> passive
traka	mandraka	‘raise’	theme
orina	manorina	‘erect’	theme
idina	midina	‘lower’	theme
verina	mamerina	‘return’	theme

Some examples are illustrated in (8).⁶

- (8) a. Aoriko ny trano. (a-orina-ko)
 a.build.1sg(gen) det house
 ‘I’m building a house.’ (lit. ‘The house is being built by me.’)
- b. Haveriny ny boky. (h-a-verina-ny)
 fut.a.return.3(gen) det book
 ‘She will return the book.’ (lit. ‘The book will be returned by her.’)

These verbs have only one passive form and thus lack a *-Vna* variant.

Similarly, there are verbs that have only the *-Vna* passive. Some verbs in this category are given in (9).

(9)

root	active verb	meaning	subject of <i>-Vna</i> passive
haja	manaja	‘respect’	theme
ila	mila	‘need’	theme
lemy	mandemy	‘weaken’	theme
vaky	mamaky	‘read; break’	theme

⁵ In what follows, I provide illustrative examples in the tables. See the appendix for more extensive tables.

⁶ For the remainder of this chapter, I will try to provide glosses that are the most natural translations of the Malagasy. Where necessary, I will also give literal translations. Only in this subsection do I provide a morphological decomposition of the verbs.

Typical clauses with *-Vna* passives are in (10).

- (10) a. Vakin-dRasoa i^hlay boky. (vaky-ina-Rasoa)
 read.Vna.gen.Rasoa def book
 ‘Rasoa is reading that book.’
- b. Hajain-dRasoa i^hBakoly. (haja-ina-Rasoa)
 respect.Vna.gen.Rasoa Bakoly
 ‘Rasoa respects Bakoly.’

I now turn to three instances where there is an alternation between the two passive forms. These alternations will be the focus of the remainder of this chapter.

2.2.2 *Two passives*

The verbs that allow both passives can be subdivided into three groups.⁷ In the first group, the verb takes the *a*-passive to promote an instrument to subject. The instrumental use of the *a*-passive is quite wide-spread.

(11) Case I

root	active verb	meaning	subject of <i>a</i> -passive	subject of - <i>Vna</i> passive	subject of CT
didy	mandidy	‘cut’	instr	theme	instr
fehy	mamehy	‘tie’	instr	theme	instr
fefy	mamefy	‘fence in’	instr	theme	instr
rakotra	mandrakotra	‘cover’	instr	theme	instr

The examples in (12) illustrate that for Case I verbs, the *a*-passive promotes an instrument, while the *-Vna* passive is used to promote the theme. (12a) illustrates the basic active clause and (12b,c) are the passive counterparts. The CT clause in (12d) is provided for comparison.⁸ In

⁷ Pearson (1998a) proposes four classes of verbs that take the *a*-passive, three of which align with my three groups. The fourth allows only the *a*-passive. I discuss this class of verbs in 4.3.

⁸ As noted in chapter 1, CT morphology is in one sense a combination of AT and *-Vna*. Moreover, recall that in a CT clause, a wide range of elements may be promoted to subject. In the

(12b-d), I have omitted the agent for clarity; a genitive agent is always possible, however.

- (12) a. Nandidy ny hena tamin'ny antsy Rasoa.
 pst.AT.cut det meat pst.P.gen.det knife Raso
 'Raso cut the meat with the knife.'
- b. Adidy ny hena ny antsy. instrument
 a.cut det meat det knife
 'The knife is used to cut the meat.'
- c. Didiana amin'ny antsy ny hena. theme
 cut.Vna P.gen.det knife det meat
 'The meat is cut with the knife.'
- d. Andidiana ny hena ny antsy. instrument
 CT.cut det meat det knife
 'The knife is used to cut the meat.'

Hence the verbs in (11) take both types of affix, each used for different arguments: instruments (*a-*) or themes (*-Vna*). As illustrated in (12d), CT is also possible for instruments. The alternation between CT and passive will be discussed below.

Parallel to the examples above, there are verbs that take a (material) theme⁹ and a goal (or location) that allow for the *a-/-Vna* alternation.

tables below, I therefore only indicate which of the relevant arguments of the verb are promoted to subject with CT.

⁹ Rappaport and Levin (1988) refer to this argument as "locatum". In what follows, I will continue to use "material theme" in connection with Case II verbs, reserving "locatum" for a broader class of arguments. See section 2.3.1.

(13) Case II

root	active verb	meaning	subject of <i>a-</i> passive	subject of - <i>Vna</i> passive	subject of CT
fatratra	mamatratra	‘stuff’	mat theme	goal	mat theme
lafika	mandafika	‘pad’	mat theme	goal	mat theme
raraka	mandraraka	‘scatter’	mat theme	goal	mat theme
tototra	manototra	‘fill’	mat theme	goal	mat theme

(14a) provides the standard active clause for Case II verbs with the passives given in (14b,c) and circumstantial in (14d). Once again, a genitive agent is possible in (14b-d), but omitted to simplify the examples.

- (14) a. Namatratra ny harona tamin’ny vary i Bakoly.
 pst.AT.stuff det basket pst.P.gen.det rice Bakoly
 ‘Bakoly stuffed the basket with rice.’
- b. Nafatratra ny harona ny vary. material theme
 pst.a.stuff det basket det rice
 ‘The rice was stuffed into the basket.’
- c. Nofatrarana vary ny harona. goal
 pst.stuff.Vna rice det basket
 ‘The basket was stuffed with rice.’
- d. Namatrarana ny harona ny vary. material theme
 pst.CT.stuff det basket det rice
 ‘The rice was stuffed into the basket.’

For the verbs in (13), the *a-* passive promotes the material theme, while the *-Vna* passive promotes the goal. The material theme (but not the goal) may also appear in the subject position of a CT clause, as in (14d). In passing, note that Case II verbs are similar to the English “locative alternation” class. In distinction to English, however, the goal or location is always realized as a DP, never a PP. I return to this below.

As a first attempt to simplify the data, I will conflate Case I and II

verbs. With this goal in mind, I refer to instruments and material themes as “locata”. These elements share the following properties, which will be discussed in detail below: they may appear either adjacent to the verb or in a PP; they are promoted to subject with either the *a-* passive or CT; they are (usually) optional in an active clause.¹⁰ I am not claiming that instruments and material themes are identical in all respects. For example, there are interpretational differences. As shown in (15), material themes are compatible with an instrument, but two instrumental phrases are not permitted in a single clause.

- (15) a. Nameno ny sinibe tamin’ny rano tamin’ny tavoahangy
 pst.AT.fill det pitcher pst.P.gen.det water pst.P.gen.det bottle
 i Soa.
 Soa
 ‘Soa filled the pitcher with water with the bottle.’
- b. * Nandidy antsy ny hena tamin’ny lafiny maranitra i Soa.
 pst.AT.cut knife det meat pst.P.gen.det side sharp Soa
 * ‘Soa cut the meat with the knife with its sharp edge.’

This is true in English as well, as seen by the contrast between the translations of (15a,b) (similar facts are discussed in Lakoff (1968)). However, despite these semantic differences, the voice system of Malagasy treats material themes and instruments on a par. I take the voice data as initial evidence that when realized as DPs, instruments and material themes appear in the same structural position. I will address the parallels between instruments and material themes further in section 2.3.

At this point, the reader may wonder why I am calling the *a-* prefix “passive”. The preceding data suggest that the *a-* prefix is mainly used to promote underlying PPs (material themes and instruments) to subject. Furthermore, these PPs appear more adjunct-like than argument-like. Thus the *a-* prefix appears to resemble CT rather than TT. In order to motivate following the traditional analysis of *a-* as a passive prefix, I will show that material themes and instruments *can* be realized as arguments. I first, however, turn to the third class of alternating verbs.

¹⁰ In English, both take the preposition *with*.

There is another large class of verbs that allows an alternation between *-Vna* and *a-*. In these cases, the *-Vna* indicates a goal, while *a-* marks the theme. Clearly, themes are arguments and not adjuncts, hence this class of verbs provides some initial motivation for treating the *a-* prefix as a passive morpheme.

(16) Case III

root	active verb	meaning	subject of <i>a-</i> passive	subject of - <i>Vna</i> passive	subject of CT
roso	mandroso	'serve'	theme	goal	goal
tolotra	manolotra	'offer'	theme	goal	goal
seho	manaseho	'show'	theme	goal	goal
toro	manoro	'point out'	theme	goal	goal

(17) illustrates the voice alternations for a typical dative verb.

- (17) a. Manolotra sary anao aho.
AT.offer picture 2g(acc) 1sg(nom)
'I offer you a picture.'
- b. Tolorana sary ianao. goal
offer.Vna picture 2sg(nom)
'You are offered a picture.'
- c. Atolotra anao ny sary. theme
a.offer 2sg(acc) det picture
'The picture is offered to you.'
- d. Anolorana sary ianao. goal
CT.offer picture 2sg.nom
'You are offered a picture.'

Comparing (17b) and (17d), we see that in this case, the *-Vna* passive alternates with CT.

2.2.3 Which passive?

At this point, a confusing pattern emerges. Both *-Vna* and *a-* form passives from roots. Some roots allow both affixes. In Case I, *-Vna* is used for themes. In Case III, *a-* is used for themes. Both affixes can be used for different and distinct thematic relations, however, such as goals (*-Vna*) (Case III) and instruments or material themes (*a-*) (Case I and II). The table below summarizes the distribution of voice morphology across theta-roles.

(18)

	theme	goal/locative	instrument/ material theme
<i>-Vna</i>	✓	✓	✗
<i>a-</i>	✓	✗	✓
CT	✗	✓	✓

Clearly, it is not possible to map directly from theta-roles to particular voice forms.¹¹ This may be due in part to the difficulty of independently determining the theta-role labels involved. It is also odd that instruments, normally treated as adjuncts, can passivize. Finally, CT, typically related to adjuncts, overlaps with passive, which deserves some explanation.¹² Based on the above facts, Rajaona (1972) concludes that there are two *a-* prefixes: *a1* for objects and *a2* for instruments. More recently, however, Pearson (1998a) has proposed an analysis of *a-* passive that draws on parallels in event structure between the various cases we have seen. (I will discuss Pearson's analysis in more detail in section 3 below.)

Similarly, I will argue that in spite of the variation in the different passives, there is one unified passive phenomenon. In all instances the targeted DPs are internal arguments of the verbs in question. The basic clause structure is given in (19).

¹¹ This lack of one-to-one mapping between theta-roles and voice morphology will be crucial to the discussion of voice and CT in chapter 3.

¹² To account for the overlap between passive and CT, Rabenilaina (1991) distinguishes between voice (the verbal morphology) and diathesis (the role of the element appearing in subject position). For example, (17d) is a goal diathesis with relative voice.

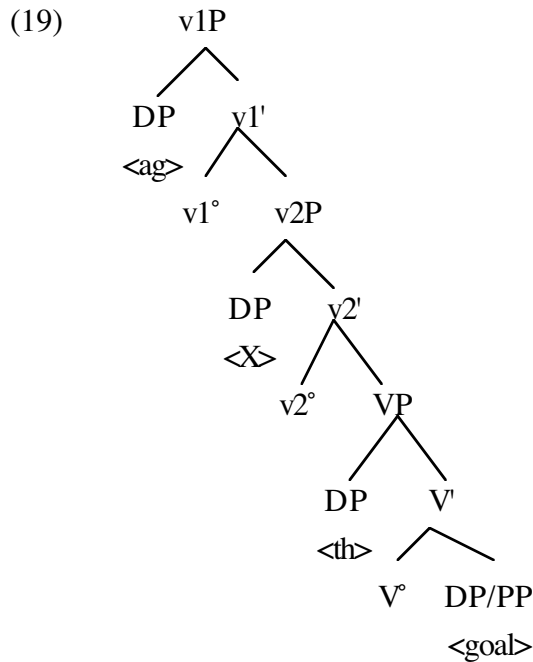

I will show that instruments, material themes and themes of dative verbs can be generated in [Spec, v2P]. The *a-* passive targets elements in [Spec, v2P] and the *-Vna* passive promotes elements from the lower VP. I turn to evidence in favour of this analysis below.

A similar structure has been proposed by Marantz (1993) for applicatives in general (including English dative shift).¹³ In other words, he argues for a position c-commanding the theme where instruments (and other things such as benefactives) can be base generated. I believe that the assumptions that underlie my analysis and his are very different, however. In section 5.3, I will present arguments in favour of base generation over syntactic movement. Importantly, in Malagasy only a subset of instruments can be generated in [Spec, v2P]. With applicatives, however, “advancement” to object of instruments appears to be much freer. I take this to indicate that applicatives involve movement and not base generation. In other words, I adopt Marantz’s analysis to a certain degree, but would not necessarily use it for his data.

2.3 Locative alternation and instrumental advancement

As mentioned above, material themes and instruments pattern together. In this section, I will explore the syntactic behavior of these elements.

¹³ Baker (1992) (fn. 2) suggests that instruments may be structurally subordinate to agents but superordinate to themes.

Crucially, I will show that both can be arguments of the verbs in question. This may appear to be an unjustified claim for instruments, which are standardly treated as adjuncts. I will show, however, that certain instruments may be base generated in an argument position.¹⁴ Only those instruments that appear overtly in the internal argument position, right-adjacent to the verb, can passivize to subject. I conclude that the *a*-passive targets this argument position rather than the adjunct instrument position. Thus although DPs with different thematic roles appear in the subject position of these different passive clauses, the DPs are arguments, not adjuncts. Moreover, the elements targeted by both types of passive are realized as DPs, not PPs. Therefore, these verbs are all “passive” as defined earlier and contrast with circumstantial topic, which is limited to objects of prepositions.¹⁵ On the other hand, instruments and material themes can alternatively be realized as PP adjuncts, in which case they are promoted to subject with CT. I now turn to evidence in favour of this analysis. In other words, I will provide data in favour of the dual status (adjunct-argument) of instruments and material themes.

2.3.1 Basic distribution

Case I and Case II verbs exhibit an alternation between the two passives (*a*- and *-Vna*) and also allow alternations in word order. I will first discuss Case II constructions, as they resemble the locative alternation verbs in English (sometimes referred to as the *spray/load* class).¹⁶ Like English, there is no morphological marking on the verb to signal the different possible orderings of the “arguments”.¹⁷ For Case II verbs, either element can appear in the canonical direct object position, adjacent to the verb, as shown in (20). In (20a) the material theme is within a PP that follows the goal, while in (20b), it is a DP that precedes the goal.

¹⁴ See Baker (1988) for discussion of the argument-like properties of instruments. He points out that noun incorporation of instruments is fairly common and claims that the canonical structural realization of an instrument is NP, rather than PP. As will be discussed below, instruments are among the class of adjuncts that pattern in some respects with arguments in Malagasy. Importantly, however, only a subset of instruments behave like arguments.

¹⁵ This informal characterization of CT will be refined in the next chapter.

¹⁶ As pointed out earlier, the locative alternation in Malagasy is not identical to English. For example, the locative/goal is not realized as a PP.

¹⁷ Since some alternations involve instruments, which are sometimes adjuncts, “argument” is not precisely the correct term.

(20) **Case II: locative alternation**

- a. goal_{DP} > material theme_{PP}
 Namafy ny tany tamin'ny voa Rḁso̥a.
 pst.AT.sow det land pst.P.gen.det seed Raso̥a
 'Raso̥a sowed the land with seeds.'
- b. material theme_{DP} > goal_{DP}
 Namafy voa ny tany Rḁso̥a.
 pst.AT.sow seed det land Raso̥a
 'Raso̥a sowed seeds in the land.'

In what follows, I will argue that as a DP, the material theme is an argument of the verb.

Turning now to Case I verbs, these are unusual from the perspective of English, but also allow different word orders.¹⁸ Parallel to material themes, instruments can appear right-adjacent to the verb in the direct object position, as shown in (21b). Following Seiter (1979), I will call this process "instrumental advancement" (although I will argue against syntactic movement). As illustrated below, Case I verbs pattern with Case II in allowing alternative word orders between a theme and another element.¹⁹ The instrumental is realized as a PP in (21a) and as a DP in (21b) with a subsequent change in word order.²⁰

(21) **Case I: instrumental advancement**

- a. theme_{DP} > instrument_{PP}
 Nandidy ny hena tamin'ny antsy Rḁso̥a.
 pst.AT.cut det meat pst.P.gen.det knife Raso̥a
 'Raso̥a cut the meat with the knife.'

¹⁸ Case I does bear some similarity to the following alternation in English.

- (i) Pat beat the table with the stick.
 (ii) Pat beat the stick against the table.

I will return to this similarity in section 4.4.

¹⁹ Baker (1996b) revises earlier claims that applicatives are only possible with transitive verbs (Baker (1988)). Interestingly, Malagasy instrumental advancement appears to be limited to transitives. I will discuss this issue further in section 5.1.

²⁰ Instruments are obligatorily indefinite in this "advanced" position: they may not appear with a determiner or a demonstrative (although adjectival modification is permitted). For Case II and III verbs, however, the appearance of the determiner is less restricted. In fact, the overall distribution of the determiner for objects in Malagasy is complex and not fully understood.

- b. instrument_{DP} > theme_{DP}
 Nandidy antsy ny hena Raṣoa.
 pst.AT.cut knife det meat Rasoā
 ‘Rasoā cut the meat with a knife.’

It is this alternate realization of instruments as DPs that is crucial to the application of passive. Recall that instruments would appear to resist a standard analysis of passive; they tend to pattern with adjuncts, as I will show in the following sections. The data in (21), however, indicate that in Malagasy, instruments can be generated in an argument position (I argue against a movement analysis in 5.3). I claim that it is precisely those instruments which can appear as arguments which can be promoted to subject with passive.

In sections 2.3.2-2.3.7, I will show that material themes and instruments can be either adjunct PPs or argument DPs. For ease of reference, in what follows, I will refer to instruments and material themes in their DP position as “locata”, since they undergo a change of location. I present three arguments in favour of adjunct status of instrument and material theme PPs: they are optional, they may be clefted, they can be promoted with CT.²¹ As DPs, on the other hand, locata are arguments: they surface immediately adjacent to the verb, they cannot be clefted and they are promoted to subject with passive. Hence instruments and material themes have two distinct syntactic realizations: adjunct and argument. (22) illustrates these two possibilities.

- (22) a. verb DP₁ [PP(adjunct) P DP₂]
 b. verb DP₂ DP₁

Since locata are arguments and since they can be promoted to subject with the *a-* prefix, I believe that the *a-* prefix is correctly characterized as a passive affix. Passive always targets internal DP arguments of the verb, never adjuncts.

²¹ In fact, instruments and material themes as PPs do not enjoy precisely the same distribution within a clause. For example, as in English, there is a strict ordering between the two: material themes always precede instruments.

2.3.2 *Optionality*

What are the tests to distinguish arguments from adjuncts? In an intuitive sense, arguments are obligatory and adjuncts are optional. It is well-known, however, that certain verbs have “optional” arguments and hence the “optionality” test is not clear-cut. Nevertheless, I refer to this test (with caution) in what follows. As shown in (23), instruments and material themes are optional and therefore pattern with adjuncts.

- (23) a. Namafy tany (tamin’ny voa) Rasoa.
 pst.AT.sow land pst.P.gen.det seed Raso
 ‘Raso sowed the land (with seeds).’
- b. Nandidy ny hena (tamin’ny antsy) Rasoa.
 pst.AT.cut det meat pst.P.gen.det knife Raso
 ‘Raso cut the meat (with the knife).’

I now turn to a Malagasy-particular construction that supports the classification of locata as adjuncts.

2.3.3 *Clefts*

Clefts can be used as a test to distinguish adjuncts from arguments. In Malagasy, clefts are formed by fronting an XP, which is followed by the focus particle *no*. (The syntax of the cleft construction is discussed in detail in chapter 4.) In general, only subjects and adjuncts can cleft when the verb is active (an AT cleft). To cleft an object, it must first be promoted to subject via passive, as shown in (24a,b). (24c) shows that an adjunct can AT cleft freely.²²

- (24) a. * [Ny lamba] no manasa Rakoto.
 det cloth foc AT.wash Rakoto
 ‘It is the clothes that Rakoto washes.’

-
- (i) a. Nameno ny sinibe tamin’ny rano tamin’ny tavoahangy i Soa.
 pst.AT.fill det pitcher pst.P.gen.det water pst.P.gen.det bottle Soa
 ‘Soa filled the pitcher with water with the bottle.’
 b. * Nameno ny sinibe tamin’ny tavoahangy tamin’ny rano i Soa.
 pst.AT.fill det pitcher pst.P.gen.det bottle pst.P.gen.det water Soa
 * ‘Soa filled the pitcher with the bottle with water.’

²² In fact, as will be seen in chapter 3, not all adjuncts can AT cleft in this manner. However, if a non-subject can cleft, it is an adjunct.

- b. [Ny lamba] no sasan-dRakoto.
 det cloth foc wash.Vna.gen.Rakoto
 'It is the clothes that are washed by Rakoto.'
- c. [Amin'ny Talata] no manasa lamba Rakoto.
 P.gen.det Tuesday foc AT.wash cloth Rakoto
 'It is on Tuesday that Rakoto washes clothes.'

Note that it is not simply the case that any PP may AT cleft freely. True PP arguments, such as the goal of dative verbs, cannot AT cleft.²³

- (25) * [Hoan'ny zaza] no nandroso vary Rakoto.
 for.gen.det child foc pst.AT.serve rice Rakoto
 'It's to the child that Rakoto served rice.'

AT clefting therefore distinguishes between arguments and adjuncts.

As (PP) adjuncts, instruments and material themes may AT cleft.

- (26) a. Tamin'ny rano no nameno ny tavoahangy i Sahondra.
 pst.P.gen.det water foc pst.AT.fill det bottle Sahondra
 'It's with water that Sahondra filled the bottle.'
- b. Tamin'ny antsy no nandidy hena i Bakoly.
 pst.P.gen'det knife foc pst.AT.cut meat Bakoly
 'It's with a knife that Bakoly cut meat.'

Like the optionality test in 2.3.2, AT clefting points to the adjunct status of these PPs. Similarly, the contrast between (25) and (26) is further evidence that the AT clefting of material themes and instruments occurs from an adjunct position and not from an argument PP position.

²³ Locative PP arguments can cleft, however.

- (i) Teo ambonin'ny latabatra no nametraka boky i Koto.
 pst.there on.gen.det table foc pst.AT.put book Koto
 'It was on the table that Koto put the book.'

Moreover, locative arguments are generally optional (there is some variation in judgement both within and across speakers). Hence, they may best be classified as adjuncts.

2.3.4 Prepositions

In the preceding sections, I have argued that instruments and material themes can be realized as adjuncts. I will now present further evidence in favour of the PP status of these adjuncts. As has been exemplified in the above data, material themes and instruments commonly surface as the object of a preposition, *amin'*. Consider now CT clauses. Instruments and material themes can be promoted to subject with CT, which has been traditionally linked to adjuncts and PPs. Descriptively, when a PP is promoted to subject with CT, the P is dropped because there are no PP subjects in Malagasy (see (27a)). On the other hand, if the PP is in a CT cleft, the P can surface (although it is optional).

- (27) a. Andidiana ny hena ny antsy.
 CT.cut det meat det knife
 ‘The knife is used to cut the meat.’
- b. [(Amin')ny antsy] no andidiana ny hena.
 (P.gen.)det knife foc CT.cut det meat
 ‘It is the knife that is used to cut the meat.’

I will discuss the interaction between circumstantial topic and the cleft construction in more detail in chapter 3. Crucially, the data in (27b) show that when an instrument is promoted to subject with CT, it is being promoted from the PP position. The same is true for material themes. This will contrast with passive, to be discussed immediately below.

Summing up, we have seen that material themes and instruments pattern with adjuncts when they are realized as PPs. I will now turn to evidence that when DPs, they are arguments. Evidence comes from word order, clefting and the lack of prepositions in clefts. Due to their argument status, they will be promoted with passive. Thus instruments and material themes have a dual status, realized either as arguments or adjuncts.

2.3.5 Arguments: Word order

In examples (20)-(21) at the beginning of section 2.3.1, I showed that instruments and material themes can appear as DPs, right-adjacent to the verb. In this position, they behave like internal arguments. As with

“normal” direct objects (i.e. non-alternating), an adverb cannot intervene between the verb and an indefinite DP locatum.²⁴ (28) illustrates adverb ordering for a verb and object.

- (28) a. Manasa lamba **tsara** Rakoto.
 AT.wash clothes good Rakoto
 ‘Rakoto washes clothes well.’
- b. * Manasa **tsara** lamba Rakoto
 AT.wash good clothes Rakoto

(29) shows that this same ordering restriction applies to “advanced” instruments.

- (29) a. Mandidy antsy **tsara** ny hena Rasoa.
 AT.cut knife good det meat Raso
 ‘Raso cuts the meat well with a knife.’
- b. * Mandidy **tsara** antsy ny hena Rasoa.
 AT.cut good knife det meat Raso

The above data indicate that when locata appear as DPs next to the verb they pattern with direct objects with respect to adverb placement. I conclude that as DPs, locata are in an argument position (not adjunct).

Due to the strict adjacency, it may appear as if the locatum has “incorporated” into the verb or that the examples are a kind of verb-noun compound. I will show, however, that the instrumental advancement and locative alternation illustrated above are neither noun incorporation nor compounding. In non-active voices, for example, a genitive agent can surface between the verb and the locatum, as shown in (30a). It is not possible for the locatum to separate the verb and the genitive agent, as in (30b).

²⁴ Recall that locata are usually indefinite.

Chapter 2

(30) a. Didian'i Bozy antsy ny hena.
cut.Vna.gen.Bozy knife det meat
'The meat is cut by Bozy with a knife.'

b. * Didiana antsin'i Bozy ny hena.
cut.Vna knife.gen.Bozy det meat

Furthermore, note that it is possible to coordinate the material theme and the goal to the exclusion of the verb.

(31) a. Nandrakotra bodofotsy ny fandriny sy lamba ny latabatra
pst.AT.cover blanket det bed.gen.3 and cloth det table
i Sahondra.
Sahondra
'Sahondra covered her bed with a blanket and the table with a cloth.'

b. Nanindrana antsy ny trondro sy lefona ny omby i Sahondra.
pst.AT.pierce knife det fish and spear det ox Sahondra
'Sahondra pierced the fish with a knife and the ox with a spear.'

Consider (31a). Although *bodofotsy* 'blanket' could potentially have incorporated into the verb *nandrakotra* 'cover', there is no host for incorporation of *lamba* 'cloth'. If incorporation (in some sense) occurs with these verbs, it must therefore be optional (and somehow ruled out in (30b)) or obtains at LF. The data in (30)-(31) indicate that instrumental advancement and the locative alternation are neither noun incorporation nor compounding.

As further evidence against compounding, note that the advanced instrument is referential: it introduces a DP into the discourse which may be referred to by a pronoun, as in (32).

(32) Tsy nandidy antsy ny hena Rabe satria tsy maranitra ilay izy.
neg pst.AT.cut knife det meat Rabe because neg sharp def 3(nom)
'Rabe didn't cut the meat with the knife because it wasn't sharp.'

Since words tend to be referentially opaque (Postal (1969; DiSciullo and

Williams (1987)), (32) suggests that the verb and the advanced instrument do not form a lexical unit.²⁵

Summing up, the data in this section indicate that as DPs, locata have the same distribution as other direct objects. I take this as initial evidence in favour of analyzing locata as arguments of the verb. I now turn to further evidence in favour of this analysis.

2.3.6 *Clefts again*

Recall that only subjects and adjuncts can AT cleft, never internal arguments. Moreover, in section 2.3.3, we saw that as PPs, material themes and instruments can AT cleft, which we took as evidence in favour of adjunct status. As DPs, on the other hand, neither the material theme nor the instrument may be clefted in an active clause, as illustrated in (33).²⁶

- (33) a. * [(Ny) rano] no nameno ny tavoahangy i Sahondra.
 (det) water foc pst.AT.fill det bottle Sahondra
 ‘It’s water that Sahondra filled into the bottle.’
- b. * [(Ny) antsy] no nandidy hena i Bakoly.
 (det) knife foc pst.AT.cut meat Bakoly
 ‘It’s a knife that Bakoly cut meat with.’

The ungrammaticality of (33) indicates that in their DP positions, both the material theme and the instrument are arguments of the verb and hence cannot AT cleft. Thus locata not only show the same basic word order distribution as arguments, they are also subject to similar extraction constraints.

2.3.7 *Prepositions again*

In section 2.3.4, I claimed that as PPs, instruments and material themes are promoted to subject with CT. Some evidence for the PP status came from the CT cleft construction, where the preposition may be overt (see (27b)).

²⁵ The opacity of words has been challenged in the literature, however (Sproat (1988)). Thus on its own, (32) presents weak evidence at best against a lexical analysis.

²⁶ Clefts of bare NPs are in principle possible. Hence (i) is grammatical.

(i) Lamba no sasan-dRakoto.
 cloth foc TT.wash.gen.Rakoto
 ‘It’s clothes that are washed by Rakoto.’

Thus it is not the presence or absence of a determiner in (33) that determines grammaticality.

If locata are promoted to subject with passive from the DP position, not from the PP position, we expect prepositions to be unavailable in a cleft construction in a passive clause. In fact, the preposition is prohibited from surfacing in a cleft of an instrument with the *a-* passive. This is shown in (34b).

- (34) a. [Ny antsy] no adidy ny hena.
 det knife foc a.cut det meat
 ‘It is the knife that is used to cut the meat.’
- b. * [Amin’ny antsy] no adidy ny hena.
 P.gen.det knife foc a.cut det meat

The ungrammaticality of (34b) suggests that the *a-* passive involves promotion from an internal DP argument position, not from the object of the preposition.

The fact that material themes and instruments can be promoted to subject via either passive or CT is indicative of their dual status. They can be arguments, in which case there is no preposition and passive applies. They can equally be adjuncts, be selected by a preposition and be promoted to subject with CT.

2.3.8 A prediction

The analysis of instrumental and locative advancement feeding passive makes a clear prediction: if an element cannot appear in an argument position, the *a-* passive should be impossible. Let us consider instruments. Not all verbs allow an instrument to appear in the direct object position. Crucially, in these cases, there is no *a-* passive form of the verb. (35a) shows that like *mandidy* ‘cut’, *mihinana* ‘eat’ may take a DP theme and a PP instrument. Unlike with *mandidy* ‘to cut’, however, the instrument may not appear right-adjacent to the verb, as shown by the ungrammaticality of (35b). Moreover, *mihinana* has no *a-* passive, as in (35c).

- (35) a. Nihinana hena tamin’ny antsy Raṣoa.
 pst.AT.eat meat pst.P.gen.det knife Rasoa
 ‘Rasoa ate meat with the knife.’

- b. * Nihinana antsy ny hena Raṣoa.
pst.AT.eat knife det meat Raso
- c. * Nahinan-dRaso ny hena ny antsy.
a.eat.gen.Raso det meat det knife

The proposed dependency between advancement and passive remains to be verified against a large number of verbs, but initial investigation suggests that the former feeds the latter.²⁷

Unfortunately, this correlation is not perfect. It seems that instrument advancement is subject to lexical restrictions that remain poorly understood. For example, the only instrument that can appear as an argument of *mandidy* 'cut' is *antsy* 'knife' (it is also the only instrument that can be used with the *a-* passive of *mandidy*). Moreover, some verbs allow instrument advancement but have lost the *a-* passive form. This in fact may be a tendency across the language to reduce the number of passive forms per verb. Several speakers, for example, reject the *a-* passive of *mandidy* 'to cut' in favour of CT. This pattern was noted by Keenan (1976) and appears to be still valid. I claim, nevertheless, that if a verb has an *a-* passive, it must allow instrument advancement. In other words, the availability of the *a-* passive for instruments is linked to the argument status of the instrument.

Summing up, we have seen that material themes and instruments share certain properties. As DPs, they appear in argument positions and cannot AT cleft. As PPs, they are adjuncts and hence can AT cleft. Furthermore, these two different realizations (DP-PP) correlate with different voice morphology: passive promotes DPs and CT promotes PPs. I will compare these properties with those of dative verbs immediately below.

2.4 Dative verbs

We now turn to the third class of verbs, datives. In many ways, these resemble their English counterparts, the most well-known being 'give'. (*manome* 'give' does not allow the *a-/-Vna* alternation, however, and will

²⁷ Some examples are given in the appendix, under Table 3.

therefore not be discussed.²⁸) Like Case I and II verbs, Case III (dative) verbs have two passive forms. There are some differences, however, between Case I and II on the one hand and Case III on the other. I will show that these differences are due to the nature of the arguments of these verbs.

I repeat the voice paradigm for dative verbs in (36) for ease of reference.

- (36) a. Manolotra sary anao aho.
 AT.offer picture 2sg(acc) 1sg(nom)
 ‘I offer you a picture.’
- b. Tolorana sary ianao. goal
 offer.Vna picture 2sg(nom)
 ‘You are offered a picture.’
- c. Atolotra anao ny_sary. theme
 a.offer 2sg(acc) det picture
 ‘The picture is offered to you.’
- d. Anolorana sary ianao. goal
 CT.offer picture 2sg(nom)
 ‘You are offered a picture.’

As illustrated in (37), there appear to be three basic word order possibilities with these verbs in the active.

(37) **Case III: dative shift**

- a. Nandroso (ny) vary hoan’ny zaza i Bakoly.
 pst.AT.serve (det) rice for’det child Bakoly
 ‘Bakoly served rice to the child.’

²⁸ This gap clearly shows that the availability of the *a-* passive is lexically determined. There is no thematic difference between the theme of *manome* ‘give’ and the theme of *manolotra* ‘offer’. Nevertheless, the *-Vna* passive promotes the former and the *a-* passive promotes the latter.

- b. Nandroso (ny) vary ny zaza i Bakoly.
 pst.AT.serve (det) rice det child Bakoly
 ‘Bakoly served rice to the child.’
- c. Nandroso ny zaza ny vary i Bakoly.
 pst.AT.serve det child det rice Bakoly
 ‘Bakoly served the child the rice.’

In (37a), the theme is realized as a DP and the goal as a PP. The preposition may be omitted, as in (37b). (37b) is a double object construction that maintains the theme>goal word order. This order may be reversed as in (37c).

The dative shift in (37c) appears puzzling when compared to the Case I and II verbs discussed above. Does (37c) involve base generation of the goal in an object position along the line of instrumental advancement? I suggest that this is in fact not the case. The shifted goal in (37c) does not pattern with instrumentals or material themes. For example, the goal in this position must be definite, in contrast to instruments and material themes, which tend to be indefinite.

- (38) * Nandroso zaza (ny) vary i Bakoly.
 pst.AT.serve child (det) rice Bakoly
 ‘Bakoly served a child rice.’

Furthermore, the goal passivizes with the *-Vna* suffix, as shown in the example in (36b). This contrasts with *locata*, which are promoted with the *a-* prefix. Finally, as pointed out by Pearson (forthcoming) and confirmed with other native Malagasy speakers, the order goal>theme is highly marked and not possible with all dative verbs. To account for the change in word order in (37c), I assume that Malagasy has limited VP-internal “scrambling” of arguments. Thus (36c) is not representative and I will not further discuss this ordering.

(37a,b) indicate that the goal of a dative verb may be realized either as a DP or as a PP. Are these argument or adjunct positions? To account for these data, Pearson (1999; to appear) proposes a syntactic difference between the DP-PP and the DP-DP constructions. He cites data from

binding and coordination to support this distinction. My consultants, however, do not agree with the judgements. Instead, I assume that goals are freely generated as DPs or PPs. Moreover, I show that goals are optional arguments. Recall the two tests for the argument-adjunct distinction: optionality and AT clefting. In general, the goal of dative verbs is optional.

- (39) Nandroso vary i_Bakoly.
 pst.AT.serve rice Bakoly
 ‘Bakoly served rice.’

On the other hand, the goal cannot AT cleft, either as a DP or a PP.

- (40) * [(Hoan’)ny zaza] no nandroso vary i_Bakoly.
 (for.gen) det child foc pst.AT.serve rice Bakoly
 ‘It’s to the child that Bakoly served rice.’

Clefting shows that although optional, the goal patterns with arguments. It is therefore not surprising that it passivizes to subject (as shown in (36b)). Finally, since the goal can be a PP, it can be promoted to subject with CT (illustrated in (36d)). I conclude that the goal is an optional argument of these verbs and can be generated either as a DP or a PP.

Turning next to the themes of dative verbs, these are promoted to subject with the *a-* passive, like the instruments and material themes discussed above. Unlike instruments and material themes, themes are obligatory arguments of dative verbs and cannot be omitted.²⁹

- (41) * Nandroso ny zaza i_Bakoly.
 pst.AT.serve det child Bakoly
 ‘Bakoly served the child.’

As seen by the word order in (37), themes surface next to the verb. Moreover, themes are only realized as DPs, never PPs.

²⁹ (41) is grammatical, but means ‘Bakoly welcomed the child’.

- (42) * Nandroso ny zaza tamin'ny vary i Bakoly.
 pst.AT.serve det child pst.P.gen.det rice Bakoly
 'Bakoly served the child the rice.'

In this way, themes are purely argumental, unlike instruments and material themes, which have a dual status. In other words, they cannot cleft and cannot be promoted to subject with CT.³⁰

- (43) a. * [Ny vary] no nandroso ny zaza i Bakoly.
 det rice foc pst.AT.serve det child Bakoly
 'Bakoly served the child the rice.'
- b. * Nandrosoan'i Bakoly ny zaza ny vary.
 pst.CT.serve.gen.Bakoly det child det rice
 'Bakoly served the child the rice.'

Not surprisingly, themes of dative verbs are arguments in the syntax.

The core difference between Case I, II verbs and Case III verbs lies in the argument/adjunct status and the category of the elements associated with these verbs. For Case I and II verbs, the instruments and material themes can be realized either as DPs or PPs, as arguments or adjuncts. For Case III verbs, the goals are either DPs or PPs, but are always arguments (albeit optional ones). Themes are uniformly DP arguments. (44) sums up the different classes.

- (44) a. Case I, II i. verb DP₁ [PP(adjunct) P DP₂]
 ii. verb DP₂ DP₁
 b. Case III verb DP₁ (P) DP₂

Nevertheless, these verbs all share certain properties. They have two passive forms, one of which (the *a-* passive) is used for instruments, material themes and themes of dative verbs. What unifies this group? The next sections answer this question.

³⁰ (43b) is grammatical under an irrelevant reading where the theme is understood as partitive. These partitive readings arise when a theme is promoted to subject with CT. See chapter 3 for a discussion of the connection between partitivity and CT.

3 Pearson (1998a)³¹

In order to provide a unified analysis of passive, Pearson (1998a) suggests that the elements promoted with the *a-* passive are all “displaced themes”.³² Rappaport and Levin (1988) refer to this type of object as “locatum”. The *-Vna* passive, on the other hand, indicates a goal or endpoint of the action described. Pearson translates the event structure of such verbs directly into phrase structure. The locatum (the displaced theme) is the specifier of a small clause headed by GO. The goal is contained in a resultative small clause complement of TO.

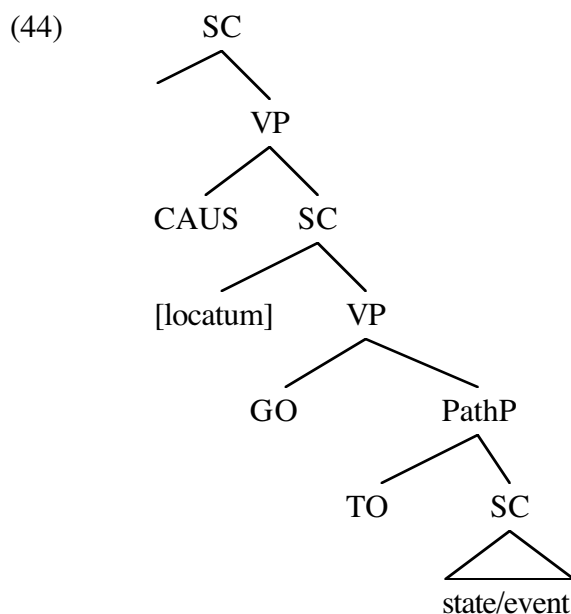

The following examples illustrate Pearson’s analysis.

- (45) a. Nandroso vary ny zaza i..Bakoly.
 pst.AT.serve rice det child Bakoly
 ‘Bakoly served rice to the child.’
- b. [SC vary GO [PathP TO [SC ny zaza]]]
 rice det child

³¹ This section draws on a conference presentation given by Matt Pearson. Since then, he has further refined his theory of these alternations, which will appear as part of Pearson (forthcoming). Since this thesis is still forthcoming, my discussion is limited to an early stage of his work.

³² Kroeger (1990) describes an affix in Kimaragang Dusun which is used for the promotion of displaced themes. Thus these languages appear to be syntactically sensitive to this classification.

- (46) a. Nandidy antsy ny hena Raṣoa.
 pst.AT.cut knife det meat Rasoā
 ‘Rasoā cut the meat with the knife.’
- b. [SC antsy_i GO [PathP TO [SC PRO_i didy ny hena]]]
 knife cutting det meat

In (45) and (46), *vary* ‘rice’ and *antsy* ‘knife’ are locata and hence appear in the specifier of the GO small clause. Note that the embedded small clauses are distinct. In particular, there is a PRO in (46b), controlled by the locatum *antsy* ‘knife’. Intuitively, the instrument is both a locatum and the external argument of the lower verb. There is no such control relation in (45b). This difference between instruments and other locata will become important in the following discussion.

Overall, I agree with Pearson’s observations and the analysis presented in section 4 posits a particular phrase structure position for locata. I differ, however, in the overall phrase structure representation. In particular, I see problems with the resultative small clause structure he assumes. Let us first examine Pearson’s motivation for the PRO in (46b).

Pearson suggests that the availability of the *a-* passive is tied to the type of instrument involved: tools versus aides. The distinction is one that draws on observations by Lakoff (1968); Wojcik (1976); Marantz (1984). Consider the following pairs.

- (47) a. Sigourney cut the salami with this knife.
 b. This knife cut the salami.
- (48) a. Sigourney ate the salami with this knife.
 b. * This knife ate the salami.

In (47a), *this knife* is a “tool” as shown by the grammaticality of (47b). In (48a), however, *this knife* is an “aide” and (48b) is ungrammatical.³³ Recall

³³ See Brunson (1992) for arguments that the distinction between (47) and (48) is not due to different types of instruments. Instead, she suggests that ‘eat’ requires its subject to be sentient, while ‘cut’ does not. Hence an instrument can be the subject of the latter but not the former. My

from example (35) in section 2.3.8 that in Malagasy *mandidy* ‘cut’ has an *a*-passive while *mihinana* ‘eat’ does not. The examples in (49) and (50) appear to support the connection between the *a*-passive and the possibility of the instrument appearing as the subject of an active verb.

(49) *mandidy* ‘cut’: instrument ✓subject of AT verb, ✓subject of *a*-passive

a. Mandidy tsara ny hena ity antsy ity.
 AT.cut good det meat this knife this
 ‘This knife cuts meat well.’

b. Adidy ny hena ny antsy.
 a.cut det meat det knife
 ‘The knife is used to cut the meat.’

(50) *mihinana* ‘eat’: instrument *subject of AT verb, *subject of *a*-passive

a. * Mihinana tsara ny hena ity antsy ity.
 AT.eat good det meat this knife this
 * ‘This knife eats meat well.’

b. * Nahinan-dRasoana ny hena ny antsy.
 a.eat.gen.Rasoana det meat det knife

Hence, cutting seems to involve a tool and eating an aide in Malagasy, as in English. Pearson’s phrase structure encodes the semantic difference between the two instrumentals. In other words, the ability of an instrumental to act as an “argument” of the verb is linked to its semantic interpretation.

Ideally, the correlation in (49) and (50) should hold for all instances of the *a*-passive. This is not the case, however. For example, themes that normally take the *a*-passive cannot be the subject of an active verb.

analysis of Malagasy is similar in spirit: whether or not an instrument can be “advanced” to object is determined in part by the semantics of verb. See section 4.2 for discussion.

(51) *manondraka* ‘water’: material theme *subject of AT verb, ✓*a*-passive

- a. * Manondraka tsara ny voninkazo ny ranjo.
 AT.water good det flower det water
 * ‘Water waters flowers well.’

- b. Natondraka ny voninkazo ny ranjo.
 pst.a.water det flower det water
 ‘The water was watered on the flowers.’

(52) *mandroso* ‘serve’: theme *subject of AT verb, ✓*a*-passive

- a. * Mandroso tsara ny zaza ity vary ity.
 AT.serve good det child this rice this
 * ‘This rice serves to children well.’

- b. Naroso ny zaza ity vary ity.
 pst.a.serve det child this rice this
 ‘This rice was served to the child.’

It is therefore unclear whether such elements could control the PRO in Pearson’s structure. Therefore, Pearson must posit two different small clause types associated with change of location (compare (45b) and (46b)). According to Pearson, material themes and themes do not control PRO and the ungrammaticality of (51a) and (52a) is not unexpected. This “solution” immediately raises the question of the difference between the two small clause types. Is there any independently motivated distinction between the two? Moreover, it is not clear how the DP *ny zaza* ‘the child’ can be a state or event in the SC in (45b).

More importantly, however, even within the class of instruments, Pearson’s correlation does not hold. In other words, the connection between an instrument appearing as the subject of an *a*-passive clause and as the subject of an AT verb is limited. In passing, Pearson does not state whether this correlation is a one-way implication (as in (53a,b)) or a bi-directional (as in (53c)).

- (53) a. instrument subject of *a*-passive → instrument subject of AT verb
 b. instrument subject of AT verb → instrument subject of *a*-passive

- c. instrument subject of AT verb ↔ instrument subject of *a*-passive

Let us consider (53a). For this to be false, we need to find an example of a verb that allows the promotion of an instrument with the *a*-passive but does not allow the instrument to be the subject of an AT verb. As shown by (54b), *ny fahita lavitra* ‘binoculars’ is promoted with the *a*-passive. (54c), however, where this instrument is the subject of the AT verb, is ungrammatical.

- (54) *mjiery* ‘watch’: instrument *subject of AT verb, ✓*a*-passive
- a. Nijery fahita lavitra ny vorona Rakoto.
 pst.AT.watch nm.AT.see far det bird Rakoto
 ‘Rakoto watched the birds with the binoculars.’
- b. Najerin-dRakoto ny vorona ny fahita.....lavitra.
 pst.a.watch.gen.Rakoto det bird det nm.AT.see far
 ‘The binoculars were used by Rakoto to watch birds.’
- c. * Mijery tsara (ny vorona) ny fahita.....lavitra.
 AT.watch good (det bird) det nm.AT.see far
 ‘Binoculars watch birds well.’

(54c) indicates that the instrument ‘binoculars’ patterns semantically with “aides” or “facilitating instruments” rather than with “tools”. Yet the *a*-passive is grammatical.

To falsify (53b), we need a verb that allows an instrument as the subject when the verb is active, but does not promote the instrument to subject with the *a*-passive. As shown in (55a,b), *mamoha* ‘wake’ can take an instrument as a PP or as the subject of the AT verb. Instrumental advancement is impossible (55c), however, and there is no *a*-passive to promote the instrument to subject (55d).

- (55) *mamoha* ‘wake’: instrument ✓subject of AT verb, **a*-passive
- a. Namoha an’i Koto tamin’ny lakolosy Raṣoa.
 pst.AT.wake acc.Koto pst.P.gen.det bell Rasoā
 ‘Rasoā woke Koto with the bell.’

- b. Namoha an'i Koto ny lakolosy.
 pst.AT.wake acc.Koto det bell
 'The bell woke Koto.'
- c. * Namoha lakolosy an'i Koto Raṣoa.
 pst.AT.wake bell acc.Koto Raso
- d. * Navoha an'i Koto ny lakolosy.
 pst.a.wake acc.Koto det bell

Pearson's correlation clearly does not hold in either direction (and clearly not bi-directionally). I therefore conclude that his test for tools versus aides is not helpful in determining the range of the *a*- passive. The fact that some instruments can be AT subjects is tangential to the question of passive. As will become clear in the next section, it is the instrument appearing in an internal argument position that determines passive. In other words, the grammaticality of the instrumental advancement in (54a) is crucial to the grammaticality of the passive in (54b). Similarly, the ungrammaticality of (55c) determines the ungrammaticality of (55d).

I agree, however, with Pearson's observation that the elements targeted by the *a*- passive are locata. This can be made evident by comparing the grammatical *a*- passive in (54b) with the ungrammatical (56).

- (56) * Najerin-dRakoto ny vorona ny solomaṣo.
 pst.a.watch.gen.Rakoto det bird det glasses
 'The glasses were used by Rakoto to watch birds.'

When asked about the difference between (54b) and (56), my consultant replied that you have to adjust binoculars, while glasses just sit on one's face. This impressionistic response indicates that the *a*- passive is in fact sensitive to certain semantic features of the promoted element. I will elaborate further on this common interpretation in the following section.

4 A unified analysis of passive

4.1 Structure

Although our basic observations are the same, I will propose a slightly different phrase structure from Pearson's. I adopt a VP-shell structure à la Chomsky (1995), augmented with an additional v2P between the higher v1P (where agents are generated) and the lower VP (the domain of internal arguments such as themes and goals).³⁴

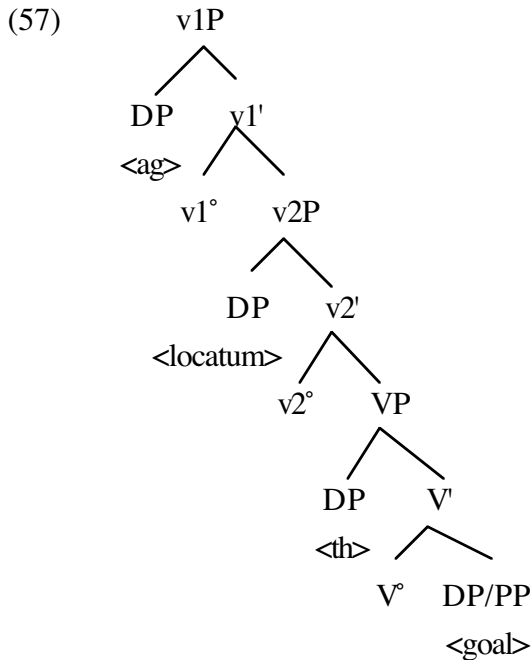

I suggest that instruments, material themes and the themes of dative verbs (= locata) may be base generated in the specifier position of v2P. The label of this projection is not crucial to the argument. Importantly, the locatum is in a specifier (argument) position in the verbal projection.³⁵

Passive results from the loss of accusative Case. For transitive verbs, the internal argument then moves to [Spec, IP] for nominative Case.

³⁴ On the relative position of themes and goals, I assume theme>goal, following Baker (1996a). Recall that in Malagasy, both NP and PP goals follow the theme, with a few exceptions. The position of themes and goals is subject to debate in the literature, a topic I touch on in section 7.2.

³⁵ As pointed out by Jonathan Bobaljik (p.c.), the *a*-passive could be relativized, rather than defined over a particular position. In other words, the *a*-passive would promote the highest argument below the agent. Note that this approach still requires instruments and material themes to be generated in a position c-commanding the theme/goal. Although attractive in current views of “shortest move”, I believe that this analysis misses certain generalizations. For example, as I will discuss below, if locata all appear in one particular position we can easily capture facts about transitives that only have the *a*-passive. For these verbs, their single internal argument will appear in [Spec, v2P].

Recall that some verbs will take the *a-* passive and others the *-Vna*. In cases where there is no alternation, the choice between the two affixes is lexically determined (but see below for discussion). On the other hand, if a verb has two “internal” DP arguments, then two passive forms will generally be available. For these ditransitives, potentially either argument can raise to subject. The argument in [Spec, v2P] will be promoted to subject with the *a-* passive form (i.e. instruments, material themes, themes of dative verbs). In other words, with the *a-* passive, no accusative Case is available in [Spec, v2P]. The argument in the lower VP will take the *-Vna* passive. *-Vna* passive therefore signals the lack of Case within VP.³⁶

As for the morphology, this analysis is consistent with the strong lexicalist view, where the fully formed verb with all its affixes is inserted directly into the syntactic structure. I am more sympathetic, however, to the view that verbal morphemes head distinct projections. I tentatively suggest that the *a-* prefix is the head of v2P (\emptyset when the verb is active). The passive suffix, *-Vna*, on the other hand, is in a different head, outside the verbal projection. That one passive is a prefix and the other is a suffix is interesting and worth further investigation.

4.2 Semantics

In the discussion of Pearson’s analysis, I pointed out that semantics seem to play a role in determining which elements are promoted with the *a-* passive. I will now clarify this question. In the traditional literature on Malagasy, grammarians have suggested that semantics directly dictates the range of the *a-* passive. According to Rahajarizafy (1960), the instruments which are promoted with the *a-* passive are in some sense necessary for the action described by the verb. For example, cutting necessarily involves some cutting implement, whereas eating does not require the use of any instrument (other than the eater’s own body). Hence the instrument of ‘cut’ will be promoted with the *a-* passive, but not the instrument of ‘eat’. We have already seen this to be the case. In the discussion of the data, I have also mentioned the relevance of change of location, and therefore have used the term “locatum” for the arguments promoted with the *a-* passive. Is this notion of locatum sufficient? No, for

³⁶ Instruments, material themes and goals may also be generated within a PP. In that case, they are promoted to subject with circumstantial topic. I leave aside discussion of CT until chapter 3.

many instruments undergo change of location without allowing the *a*-passive. Recall the above discussion of *mihinana* ‘eat’ in (50). I therefore follow Rahajarizafy’s intuition that certain locata are inherent in the meaning of the verb. Furthermore, I assume that these locata are present in the LCS of the verbs and therefore can be realized as arguments. As arguments, locata can then be promoted to subject with passive. In other words, the semantics determines the structural position of the locatum. This structural position is crucial in the application of passive. In this way, I concede the importance of semantics in determining the range of the *a*-passive. Clarification of these notions will come with a careful study of the lexical semantics of these verbs. Such a study is beyond the scope of this thesis (and beyond the competence of this researcher), however, and I leave it to a future lexical semantic investigation.

4.3 Change of location

The crucial data thus far have come from two passive verbs. Necessarily, these verbs have two internal DP arguments. I have argued that the *a*-passive promotes DP arguments in [Spec, v2P], while the *-Vna* passive promotes DP arguments in the lower VP. What about verbs with a single internal DP argument? We have already seen that transitive verbs fall into two classes: those that take *a*- and those that take *-Vna*. Since I have linked [Spec, v2P] to a particular interpretation (locatum), we would expect transitive verbs that only have the *a*-passive to express a change of location. This is in fact true: the themes of these verbs undergo some change of location or orientation.³⁷

- (58) a. mandraka ‘raise’
 b. midina ‘lower’ (transitive)
 c. mandavo ‘spill’ (transitive)
 d. mamindra ‘move, displace’

Unfortunately, there is no one single syntactic test for locata. Therefore

³⁷ Traditional Malagasy grammarians have discussed the factors determining the *a*-passive with single argument verbs such as those in (58). Rahajarizafy (1960) claims that verbs that express a situating or positioning take the *a*-passive. Rajaona (1972) suggests that verbs which transform their objects take the *a*-passive. From the discussion, it should be clear that I am formalizing Rahajarizafy’s intuition.

we must rely on individual intuitions to determine whether this is the correct characterization. As mentioned above, I leave the semantics of these verbs for further investigation.

Interestingly, change of location does appear to license word order alternations in languages other than Malagasy. English change of location verbs, for example, allow alternations similar to the Malagasy data discussed in this chapter.³⁸ Well-known is the *spray/load* alternation (Anderson (1971); Rappaport and Levin (1988); Hoekstra and Mulder (1991)). Moreover, as discussed by Fillmore (1970), certain verbs of physical contact also exhibit a change in word order. Typical of this class is ‘hit’, but also ‘slap’, ‘strike’, ‘stroke’, ‘bump’.

- (59) a. Kim hit the table with the stick.
 b. Kim hit the stick against the table. (≈ (59a))

These verbs bear a strong similarity to the instrumental advancement verbs of Malagasy. Thus both Malagasy and English change of location verbs allow word order alternations with minimal interpretational effects. Interestingly, Malagasy also singles out the change of location class with different passive affixes.

Verbs of change of state (e.g. ‘break’, ‘bend’, ‘fold’, ‘shatter’, ‘crack’), however, show a radical shift in meaning with word order change.

- (60) a. Kim broke the table with the stick.
 b. Kim broke the stick against the table. (≠ (60a))

The same holds true in Malagasy. The change in meaning is all the more dramatic as the preposition remains the same. Thus it is purely position that determines which argument undergoes the change of state. (Real world knowledge determines just how the change of state is realized; (61a) *could* mean ‘Ketaka broke the stick with the table’, but this is an

³⁸ Goldberg (1995) discusses the “caused motion construction”, which subsumes the *spray/load* alternation. I have not found Malagasy equivalents to the intransitive *swarm* class.

(i) a. Bees are swarming in the garden.
 b. The garden is swarming with bees.

This may be accidental or indicate that the *swarm* class should not be grouped together with the *spray/load* class, as suggested by Jackendoff (1996) and contra Hoekstra and Mulder (1991).

unlikely interpretation.)

- (61) a. Namaky ny latabatra tamin'ny langilangy i Ketaka.
 pst.AT.break det table pst.P.gen.det stick Ketaka
 ‘Ketaka broke the table with the stick.’
- b. Namaky ny langilangy tamin'ny latabatra i Ketaka.
 pst.AT.break det stick pst.P.gen.det table Ketaka
 ‘Ketaka broke the stick against the table.’

Moreover, none of the Malagasy verbs that allow the *a-/-Vna* alternation are pure change of state verbs like *mamaky* ‘break’. Thus change of state neither licenses word order alternations nor distinct passives.

Summing up, the class of change of location verbs have a special status in the syntax. Alternating verbs in Malagasy and English all incorporate some change of location. (Change of state may of course also arise, as in the locative alternation.) In Malagasy, this class is further distinguished by the availability of different passive affixes. Again, an understanding of the precise relevance of change of location and how this interacts with syntactic structure remains to be determined.

5 Discussion

I now discuss certain details of the above analysis. In particular, I examine how Case and transitivity interact in the alternating verbs considered above. I then look for evidence from coordination in favour of the proposed structure. Some data are promising, while others are problematic due to the unusual coordination patterns in Malagasy. I also discuss the motivation for positing base generation in [Spec, v2P] over syntactic movement. This leads to a comparison with similar alternations in other languages. I provide potential criteria for distinguishing base generation from movement in word order alternations.

5.1 Case and transitivity

I assume that the verbs that allow the *a-/-Vna* alternation can assign more than one accusative Case in the active form. This can be directly observed in the following example.

- (62) a. Nanondraka rano an-dRaso*a* i Sahondra.
 pst.AT.water water acc.Raso*a* Sahondra
 ‘Sahondra sprayed water on Raso*a*.’
- b. Nanondraka an’io azy i Sahondra.
 pst.AT.water acc.this 3(acc) Sahondra
 ‘Sahondra sprayed this on her.’
- c. Nihinana an’io i Sahondra.
 pst.AT.eat acc.this Sahondra
 ‘Sahondra ate this.’

Overt accusative Case is marked on proper names but not on lexical nouns, as seen in (62a). If we replace the noun with a pronoun, however, overt Case-marking surfaces. This is illustrated in (62b). ((62c) shows that “normal” accusative pronouns have the same surface form.) Under the proposed analysis, passive involves the loss of one of these Cases. Note that multiple accusative Case marking is in general possible in Malagasy, as illustrated by the causative below.³⁹

- (63) Nampanasa an’i Koto an-dRaso*a* ah*o*.
 pst.cause.wash acc’Koto acc-Raso*a* 1sg(nom)
 ‘I made Raso*a* wash Koto.’

Thus no special Case marking mechanisms are required for the multiple passive verbs under discussion. See Baker (1988) for a similar conclusion for applicatives in languages with multiple structural Case. Since the alternating verbs are lexically determined, it is not unreasonable to suggest that they are also lexically marked as assigning/checking two

³⁹ Both the causee and the embedded theme can passivize to subject. Unlike the alternating verbs discussed in this chapter, however, only one passive form is used, *-Vna*. Hence, (i) is ambiguous.

(i) Nampanasako an-dRaso*a* i Koto.
 pst.cause.wash.Vna.1sg(gen) acc-Raso*a* i Koto
 ‘Koto was made by me to wash Raso*a*.’
 or ‘Koto was made by me to be washed by Raso*a*.’

That only the *-Vna* passive is available is not surprising. Neither the causee nor the embedded theme qualify as displaced themes. For me, both arguments would be generated in the lower VP and hence targeted by the *-Vna* passive. Note that other than causatives, all “double accusative” verbs (e.g. datives) are precisely those under investigation in this chapter.

Cases. Structural accusative Case is available in [Spec, v2P] and in the lower VP.⁴⁰ When the instrument or material theme appears in a PP, v2P is not projected.

There remains another possibly Case-related question. As mentioned earlier, the only verbs that license these alternations in word order are transitive. There are no examples of instrumental advancement, for example, with an intransitive verb (this appears to be true for many instances of applicatives cross-linguistically, but see footnote 19). (64) indicates schematically the unattested alternation.

- (64) a. V PP(instrument)
b. * V DP(instrument)

Therefore these verbs deserve some discussion. In what follows, I speculate on the reasons for the transitivity effect. I tentatively suggest that it is due to the semantics of these verbs rather than their Case properties, *per se*.

First, recall that not all verbs that have the *a*-passive are three argument verbs. Some verbs only have the *a*-passive, which promotes the sole internal argument (see (58) above for some examples). This class of verbs encodes a change of location, as mentioned earlier and I would claim that the internal argument is generated in [Spec, v2P]. Hence there is no restriction *per se* on having an element in [Spec, v2P] and no arguments in the lower VP. But the verbs in (58) are not alternating verbs; hence they do not show whether or not alternations are possible with single argument verbs.

Similarly, certain locative alternation verbs (e.g. *mamafy* 'sow') have the goal as an optional argument and thus have the appearance of being a single argument verb. When the goal is not expressed, however, the material theme must surface as a DP, not as a PP; hence the contrast between (65a) and (65b) (compare with (64) above).

⁴⁰ Marantz (1993) assumes that structural Case is assigned in all [Spec, VP] positions. I further assume that structural Case is assigned to the goal, sister to V°.

- (65) a. Mamafy voa ny mpamboly.
 AT.sow seed det farmer
 ‘The farmer sows seeds.’
- b. * Mamafy amin’ny voa ny mpamboly.
 AT.sow P.gen.det seed det farmer

With the *-Vna* passive, however, either the DP or the PP is possible.

- (66) a. Fafazan’ny mpamboly voa ny tany.
 sow.Vna.gen.det farmer seed det land
 ‘The land is sown seeds in by the farmer.’
- b. Fafazan’ny mpamboly amin’ny voa ny tany.
 sow.Vna.gen.det farmer P.gen.det seed det land
 ‘The land is sown with seeds by the farmer.’

(65) indicates that there is no alternation available when the verb takes a single argument. Once we add another argument, as in (66), the DP-PP alternation reappears. Again, it appears that the DP-PP alternation is only permitted with transitives. This is shown schematically in (67).

- (67) a. V DP PP(instrument/material theme)
 b. V DP(instrument/material theme) DP

(67a,b) correspond to the structures underlying (66a,b). Is the difference between (64) and (67) a general pattern?

What we would be looking for is a verb like ‘walk’ (or, even better, an unaccusative) which could take either a PP instrument or a DP instrument, but no other internal arguments. And this DP instrument would passivize with the *a-* prefix. (There would be no *-Vna* alternate since ‘walk’ takes no (other) internal DP arguments.) Crucially, the verb would have to be a change of location verb to allow the instrument to be generated in [Spec, v2P]. As far as I can tell, there are no verbs like this.⁴¹ Due to the

⁴¹ There is one possible example of this, illustrated in (i).

restricted nature of “instrumental advancement” in Malagasy, this gap could simply be accidental. There are other possibilities. For example, the class of verbs discussed herein encode a *directed* change of location. In other words, the motion is directed toward an endpoint. If we take this notion as important, then it is not surprising that there is no “advancement” with unergatives. Unergatives, by definition, will lack the endpoint of motion. These are tentative speculations, however, and require a better understanding of the lexical semantics of verbs of motion. I leave this for future research. It is worth noting that Massam (1998) shows that Niuean instrumental advancement requires an agentive verb. Thus similar word order alternations display similar dependencies on the semantics of the verb.

5.2 Constituency

To provide evidence in favour of the proposed structure, I consider coordination, a classic test for constituency. Unfortunately, Malagasy coordination facts are quite complex. Moreover, with the predicate fronting analysis of word order mentioned in chapter 1, it is difficult to determine just what constituents are being coordinated. Therefore the results may be inconclusive.

In the proposed structure, the locatum forms a constituent with the goal, to the exclusion of the verb (assuming verb raising). Coordination facts suggest this to be true.

- (68) a. Nandrakotra bodofotsy ny fandriny sy lamba ny latabatra
 pst.AT.cover blanket det bed.gen.3 and cloth det table
 i Sahondra.
 Sahondra
 ‘Sahondra covered her bed with a blanket and the table with a cloth.’

-
- (i) a. Mandeha amin’ny fiara i Soa.
 AT.go P.gen.det car Soa
 ‘Soa goes by car.’
 b. Mandeha fiara i Soa.
 AT.go car Soa
 ‘Soa goes by car.’

(ia), however, is marked and (ib) has the status of a fixed expression. In this instance, *fiara* ‘car’ is promoted to subject with CT and not passive.

- b. Nanindrona antsy ny trondro sy lefona ny omby i Sahondra.
 pst.AT.pierce knife det fish and spear det ox Sahondra
 ‘Sahondra pierced the fish with a knife and the ox with a spear.’
- c. V [[_{v2P} locatum goal] and [_{v2P} locatum goal]]

(68c) illustrates the basic structure. Under the proposed analysis, the data in (68) represent v2P coordination. Similarly, VPs can be conjoined, excluding the verb and the locatum.

- (69) a. Nandidy antsy ny hena teo ambonin’ny latabatra
 pst.AT.cut knife det meat pst.there on.gen.det table
 sy ny mofo tao an-dakozia i Koto.
 and det bread pst.there at-kitchen Koto
 ‘Koto cut the meat on the table and the bread in the kitchen
 with the knife.’
- b. V locatum [[_{VP} goal PP] and [_{VP} goal PP]]

As shown schematically in (69b), (69a) is an example of lower VP coordination.

Problematic, however, are the following data, where the verb and locatum are conjoined.

- (70) a. Nandidy antsy sy nandrarak a sira ny hena Rabe.
 pst.AT.cut knife and pst.AT.pour salt det meat Rabe
 ‘Rabe cut with a knife and poured salt on the meat.’
- b. Nandroso vary sy nanolotra labiera ny vahiny i Ketaka.
 pst.AT.serve rice and pst.AT.offer beer det guest Ketaka
 ‘Ketaka served rice and offered beer to the guests.’
- c. [[_? V locatum] and [_? V locatum]] goal

In the clause structure proposed in (57), the verb and the locatum do not form a constituent to the exclusion of the goal. Do the examples in (70)

involve Right Node Raising? If, however, I assume predicate fronting, the data in (70) can be accounted for. Prior to predicate fronting, the goal moves to an XP position above v1P. Then the coordinated v1P (which contains the verb and locatum and trace of the goal) raises to [Spec, TP].

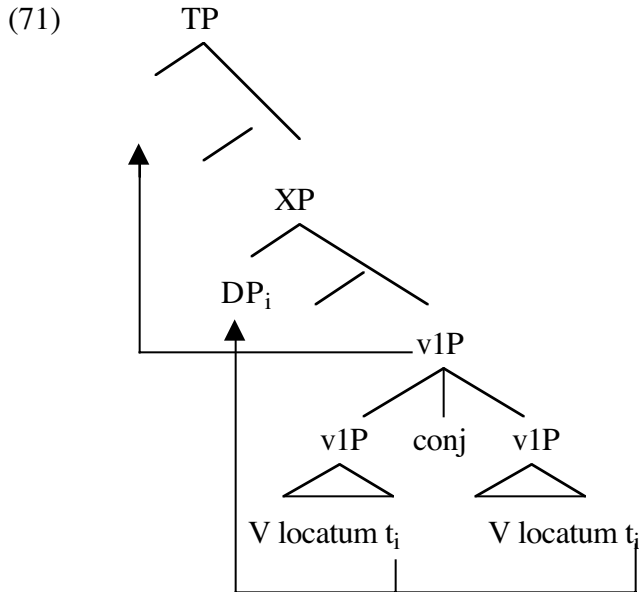

Despite its rather baroque appearance, this kind of movement is quite common in coordinated structures in Malagasy. Consider the following examples, cited by Keenan (in press):

- (72) a. Nividianako sy namaky ilay boky ianaŋo
 pst.CT.buy.1sg(gen) and pst.AT.read def book 2sg(nom)
 ‘You [[were bought+for by me and read] that book]’
- b. Nanondroako ka naka ilay toerana ianaŋo
 pst.CT.point-out.1sg(gen) and pst.AT.take def place 2sg(nom)
 ‘You were pointed out by me and took that place.’

In (72a), for example, the object *ilay boky* ‘the book’ has undergone ATB extraction to an object position. Under the predicate fronting analysis, the coordinated VPs (or similar constituent) subsequently raise to [Spec, TP].⁴²

⁴² What is unusual in these examples is that one verb is active and the other is CT. The closest English equivalent would be the following:

(i) That boat was bought by Eve and sails well.

More work is clearly required on coordination in Malagasy.

5.3 Base generation vs. movement

In the analysis presented, I have posited that certain elements (e.g. instruments) may be base generated in [Spec, v2P]. Under an alternative approach, the same element could be generated elsewhere and move into a similar position. In fact, either approach captures the basic facts about the alternations. I will now turn to some arguments in favour of base generation.

This issue arises with similar alternations in English: dative shift and locative alternation. Do the word order differences obtain from movement or from different base structures? A full range of answers has been offered in the literature. Since this topic has been treated by several researchers and a complete discussion would be beyond the scope of this chapter, I will limit myself to a brief discussion here. Recently, Baker (1997) has reviewed the literature on both dative shift and locative alternations. Baker argues that the former, but not the latter, involves syntactic movement. He offers syntactic evidence in favour of this position, but he also notes that while the locative alternation results in a clear change in aspectual meaning (affectedness), dative shift does not. For Baker, the affected argument corresponds to a structural position, the true theme position. Therefore, he claims that the locative alternation is base generated as two different underlying structures. We will see in section 6 that in Malagasy, none of the alternations discussed change affectedness relations. Following Baker's argumentation, we would then expect the different word orders to be derived via movement. In this section, however, I will argue against movement.

Although the locative, instrumental and dative alternations in Malagasy do not change the affectedness relations, there are both semantic and syntactic differences between the two structures. I will take this as indicative of base generation rather than movement. First, recall that it is possible to semantically define the class of elements that may appear in an internal DP argument position; all are displaced themes or "locata". Such a consistent pattern remains unexplained under a movement account. It would be difficult to restrict movement to [Spec, v2P] to a certain semantic class. Syntactic positions, however, tend to be

associated with interpretation (e.g. theta-assignment, operator-variable constructions). It is therefore not unreasonable to assume that only a certain semantic class of elements may be generated in [Spec, v2P].⁴³

Second, there are differences between the alternations that suggest base generation rather than movement. As has been noted for English (Gruber (1965); Lakoff (1968) and others), instrumental phrases require a truly “agentive” subject. Inanimates are not possible subjects in clauses with instrumental phrases.

(73) * The explosion killed the workers with a rock.

This is true for both instruments and material themes in Malagasy.⁴⁴

(74) a. * Namono ny mpiasa tamin’ny vato ny fipoahana.
 pst.AT.kill det worker pst.P.gen.det rock det explosion
 * ‘The explosion killed the workers with a rock.’

b. * Nanototra ny saha tamin’ny vovoka ny rivotra.
 pst.AT.fill det field pst.P.gen.det dust det wind
 ‘The wind covered the field with dust.’

On the other hand, if the material theme appears as an object, the sentence in (74b) becomes grammatical.⁴⁵

(75) Nanototra vovoka ny saha ny rivotra.
 pst.AT.fill dust det field det wind
 ‘The wind covered the field with dust.’

Therefore, whatever renders (74b) unacceptable is not present in (75).

⁴³ This distinction between movement and base generation must be applied with caution, however. For example, not all verbs in English passivize (**Kim is resembled by Sandy*). Does this entail that passive involves base generation rather than movement? I would claim that for verbs like ‘resemble’, the apparent object is not in a true direct object position. Hence passive cannot apply.

⁴⁴ The grammaticality of the English translation of (74b) shows that in English, material themes do not require an agentive subject. It is not clear why Malagasy and English differ in this respect.

⁴⁵ I have not been able to construct the equivalent of (75) with an advanced instrument. This may be due in part to the restricted nature of instrumental advancement. Moreover, inanimate agents are instrument-like and it is impossible to have two instruments in a clause.

Since the incompatibility between an inanimate subject and a PP material theme is semantic in nature, I suggest it results from the theta role assigned to the material theme within a PP. When generated in [Spec, v2P], the material theme receives a different theta role (locatum), one that is compatible with an inanimate subject. Again, the contrast in grammaticality between (74) and (75) is indicative of distinct structures underlying the two examples.

Finally, recall the difference between passive and CT clefts of instruments and material themes, discussed in sections 2.3.4 and 2.3.7. If the verb is passive, a preposition is not possible in the cleft position, as shown in (76a). If the verb is CT, however, a preposition is possible, as given in (76b).

- (76) a. [(*Amin')ny antsy] no adidy ny hena.
 (P.gen.)det knife foc a.cut det meat
 'It is the knife that is used to cut the meat.'
- b. [(Amin')ny antsy] no andidiana ny hena.
 (P.gen.)det knife foc CT.cut det meat
 'It is the knife that is used to cut the meat.'

If the *a-* passive were to involve movement from the PP position via [Spec, v2P], it is unclear how to account for the impossibility of the preposition in (76a). On the other hand, if the locatum in [Spec, v2P] is always generated as a DP, the lack of a preposition is not surprising. We will see in chapter 3 that when a PP is promoted to subject in a CT clause, the preposition is always permitted in a cleft.

In this section I have suggested some criteria to distinguish base generation from movement. I will now see how these criteria apply to word order alternations in other languages.

5.4 Cross-linguistic evidence

As I have pointed out several times, the word order alternations that arise in Malagasy are similar to English. English has both the locative alternation and dative shift. I will now briefly consider some other languages which also exhibit these alternations. Although I do not have

enough data to draw any firm conclusions, I will suggest that in some cases, the alternation is syntactic and therefore derived via movement. In other cases, a base generation analysis appears to be more appropriate.

5.5.1 Instrumental advancement

Recall that in Malagasy, certain verbs allow a certain class of instruments to appear as direct arguments. This “instrumental advancement” occurs in other Austronesian languages (e.g. Niuean (Seiter (1979)) and Madurese (William Davies, p.c.)), usually accompanied by changes in verb morphology. In Niuean, an ergative VSO language, the preposition *aki* appears cliticized onto the verb.

- (77) a. Kua hele tuai e Sione e falaoa [**aki** [e titipi haana]].
 perf cut perf erg Sione abs bread with abs knife his
 ‘Sione has cut the bread with his knife.’
- b. Kua hele **aki** tuai e Sione [e titipi haana] e falaoa.
 perf cut with perf erg Sione abs knife his abs bread
 ‘Sione has cut the bread with his knife.’

The former object of the preposition appears between the ergative agent and the absolutive theme. Madurese, SVO, uses a general-purpose valency-extending affix, *-aghi*.⁴⁶ In (78a), the instrument appears in a PP. In (78b), the instrument surfaces in the object position and the verb bears extra morphology.

- (78) a. Ali notop cendela biq korten.
 Ali AV.close window with curtain
 ‘Ali covered the window with a curtain.’
- b. Ali notop-**aghi** korten daq cendela.
 Ali AV.close-aghi curtain to window
 ‘Ali covered the window with a curtain.’

In contrast to Niuean and Madurese, the form of the verb in Malagasy

⁴⁶ *-aghi* is also used to add a causee or benefactive (William Davies, p.c.).

remains constant in these alternations.

Instruments may also be promoted to subject in Madurese (and Niuean). In these cases, the verb morphology indicates that the instrument has first been promoted to object and then to subject. The Madurese example in (79) illustrates that the verb bears both the instrumental advancement suffix (*aghi*) and the passive prefix (*e*).

- (79) Korten jhuwa e-totop-**aghi** Ali daq cendela.
 curtain det OV.close.aghi Ali to window
 ‘The curtain was used by Ali to cover the window.’

I speculate that instrumental advancement in these languages is syntactic. Looking at Niuean, for example, it appears that the range of instruments that can be “advanced” is quite broad, less restricted than in Malagasy.

- (80) Ne hopo aki e ia e kave toua
 pst jump aki erg she abs cord rope
 ‘She jumped with a rope.’

I would take this as an indication of syntactic movement. (Massam (1998), however, assumes base generation.)

5.5.2 *Locative alternation*

Drawing on data from Tagalog, Voskuil (1996) argues for a “two-stage” analysis of passive that resembles in many respects the account given here for Malagasy. As in Malagasy, some Tagalog verbs have more than one passive alternate. For example, the verb *tanim* ‘to plant’, has two passive forms, each of which promotes a different argument of the verb to subject. The examples in (81) are from Voskuil.

- (81) a. Nagtanim siya ng bulaklak sa hardin.
 perf.mag.plant 3sg.nom acc flowers obl garden
 ‘She planted flowers in the garden.’

- b. Itinanim niya ang bulaklak sa hardin.
 perf.i.plant 3sg.gen nom flowers obl garden
 ‘The flowers were planted by her in the garden.’
- c. Tinamnan niya ng bulaklak ang hardin.
 perf.plant.an 3sg.gen acc flowers nom garden
 ‘The garden was planted by her with flowers.’

In (81b), the theme of the verb (*ang bulaklak* ‘the flowers’) is the subject, while (81c) has as subject the location of planting (*ang hardin* ‘the garden’). Moreover, in (81b), the verb has a passive prefix (*i-*) and in (81c), the verb has a passive suffix (*-an*).⁴⁷ Voskuil argues against an analysis where the affixes pick out a DP with a particular theta role of the verb (agent, theme, location) and promote it to nominative (i.e. a theta-agreement analysis). Instead, he suggests that the alternation in (81) derives from the locative alternation, which modifies the verb’s argument structure. Subsequently, the verb is passivized. Voskuil’s label “two stage passive” is somewhat misleading. The first stage is a change in argument structure which allows either the material theme or the goal to be projected as the direct argument of the verb. The second stage is passive. In this way, Tagalog has only one passive, which promotes the direct object to subject. Although details of Voskuil’s analysis differ from mine (in particular, he assumes there is a single direct object position), the general conclusion is the same: the different passives are the result of different base generation structures.⁴⁸

5.5.3 *Applicative*

Outside of Austronesian, there are languages which exhibit a similar manipulation of internal arguments. More specifically, the Bantu languages are well-known for the so-called applicative construction.⁴⁹ Applicatives involve the promotion of the object of a preposition to direct object, accompanied by morphological marking on the verb. Consider

⁴⁷ Interestingly, Tagalog and Malagasy both use a prefix to promote the locatum and a suffix to promote the goal.

⁴⁸ Unlike Malagasy, however, Tagalog does not show the locative alternation in the active. Hence there is no ‘plant the garden with flowers’ variant of (81a). I am not familiar enough with the Tagalog data to speculate on the reasons for this gap.

⁴⁹ Applicatives are of course not limited to Bantu languages. Within Austronesian, Chamorro (Gibson (1980)) and Indonesian (Chung (1976a)) are argued to have applicative constructions.

the following pair from Chichewa, discussed in Baker (1988).

- (82) a. Msangalatsi a-ku-yend-a ndi ndodo.
 entertainer sp-pres-walk-asp with stick
 ‘The entertainer is walking with a stick.’
- b. Msangalatsi a-ku-yend-er-a ndodo.
 entertainer sp-pres-walk-with-asp stick
 ‘The entertainer is walking with a stick.’

In (82a), the DP *ndodo* ‘stick’ appears in a PP, while in (82b) there is no preposition and the verb bears the suffix *-ir*. Cross-linguistically applicative constructions involve datives, benefactives, instruments and locatives. Importantly for comparison with Malagasy, the Chichewa applicative feeds passive, hence the instrument in (82b) can become the subject of a passive verb, as shown in (83).

- (83) Ndodo i-ku-yend-er-edw-a.
 stick sp-pres-walk-with-pass-asp
 ‘The stick is being walked with.’

As in the Madurese example in (79), the Chichewa verb in (83) bears both the applicative and the passive morphemes. Morpheme ordering suggests that applicative has applied first, promoting the instrument to object. From this position, passive may further promote the instrument to subject.⁵⁰ Here I speculate that applicative in Chichewa is syntactic and involves movement. From the available data, it appears that applicative applies freely to different types of instruments (see example (82b) above).

Summing up, Malagasy is not unusual in allowing certain PP adjuncts to appear as DP arguments. The main difference between Malagasy and the languages mentioned in this sub-section is that Malagasy does not mark these alternations morphologically. In this way, Malagasy

⁵⁰ As noted by Marantz (1993), however, it is not always the instrument that is promoted via passive in these contexts. For my purposes, it is crucial that in order for the instrument to be promoted to subject, it must first be promoted to object. Whether further promotion occurs is irrelevant. Although all speakers of Malagasy allow *antsy* ‘knife’ to be an argument of *mandidy* ‘cut’, not all allow the passive.

resembles English: the locative alternation is not associated with any particular morphology. I do not consider the presence or absence of morphemes to be an issue. As suggested by Marantz (1993), English and Malagasy may simply have null morphemes that correspond to the applicative markers in other languages (perhaps in v_2°). More importantly, however, although all these languages appear to use the same construction (“instrumental advancement”, dative shift, applicative, etc.), the actual derivations may be different. I have suggested that some are cases of movement and others are base generated structures.

The data in this section have provided further evidence in favour of the proposed analysis. In particular, I have discussed Case assignment, constituency and the difference between base generation and movement. I now turn to aspectual properties of alternating verbs.

6 Aspect

Much work on locative alternation verbs has focussed on their aspectual properties (Anderson (1971); Rappaport and Levin (1988); Dowty (1991); Hoekstra and Mulder (1991); Tenny (1994); Jackendoff (1996)). It has been noted that when the goal is the direct object, it is interpreted as “wholly affected”.

- (84) a. Hannah loaded the apples onto the wagon.
b. Hannah loaded the wagon with the apples.

In (84a), the wagon may or may not be completely full. On the other hand, (84b) implies that the wagon is full. There is some debate, however, over the status of the material theme (*the apples*). Tenny (1994) and Dowty (1991) claim that in both examples in (84) the direct argument delimits the event (Tenny’s “measuring out” and Dowty’s “Incremental Theme”). In (84a), it is the set of apples as they get used up that measures out the progression of loading. In (84b), on the other hand, it is the wagon as it gradually fills that measures out the event.

Furthermore, both Tenny and Dowty argue that it is the direct argument that determines the telicity of the VP.⁵¹ In other words, the

⁵¹ Jackendoff (1996) disagrees with this conclusion, but I set aside his criticisms as they are largely tangential to the Malagasy facts. Dowty (1991) provides a careful discussion of telicity with consideration of the pragmatic effects of different verbs.

direct argument controls the acceptability of the temporal adverbial in the example below. Temporal modifiers indicate telicity; ‘in an hour’ is possible with telic events and ‘for an hour’ is possible with atelic events (Dowty (1979)).

- (85) a. John sprayed subway cars with this can of paint *in/for an hour.
 b. John sprayed this subway car with paint in/*for an hour.
 c. John sprayed this can of paint onto subway cars in/?for an hour.
 d. John sprayed paint onto this subway car *in/for an hour.

If the direct argument is definite (as in (85b,c)), the predicate is telic and compatible with ‘in an hour’ and not ‘for an hour’.⁵² On the other hand, if the direct argument is a bare plural or a mass noun, the predicate is atelic and only the durative adverbial ‘for an hour’ is acceptable. By definition, only incremental themes determine telicity; the direct argument in the locative alternation is therefore an incremental theme.

As we will see, similar results apparently obtain for the locative alternation in Kimaragang Dusun. In Malagasy, however, the data are less clear and require careful discussion. I will show that [Spec, v2P] is not an affected object position per se. Instead, the affected argument is determined by the root that underlies the verb.⁵³ In other words, the change in word order in the locative alternation does not change the affectedness relations. I therefore disagree with Marantz (1993), who claims that [Spec, v2P] is an affected object position.

6.1 Kimaragang Dusun

In Kimaragang Dusun there is evidence for the derived object having specific aspectual import.⁵⁴ As described by Kroeger (1990), different elements may surface in the derived object position, where they receive an “affected” interpretation. Kroeger uses the term “Undergoer” as a descriptive label for this position. Interestingly, verbal morphology encodes the thematic relation of the “Undergoer”.

⁵² As noted by Dowty (1991), the activity reading is marginally possible in (85c).

⁵³ In my discussion of the Malagasy data, I will use the term “affected object” to refer to the argument that gets “used up” by the action of the verb. See below for more discussion of aspect in Malagasy.

⁵⁴ Kroeger does point out that affectedness in Kimaragang Dusun cannot be defined in terms of change of state or telicity.

- (86) a. \emptyset -po-suwang okuh ditih sada sid pata'an.
 AV-po-enter 1sg.nom this(acc) fish loc basket
 'I will put this fish in the basket.'
- b. Monuwang okuh do pata'an do sada.
 AV-poN-enter 1sg.nom acc basket acc fish
 'I will fill the basket with fish.'

Just as in the English translations, either the theme (*sada* 'fish') or the goal (*pata'an* 'basket') can surface as the Undergoer, adjacent to the verb. The Undergoer is understood as being "affected": in (86b), for example, the basket must be completely full. The difference in interpretation is marked not only by word order, but also by the morphology on the verb: *po-* vs. *poN-*. When the endpoint of the action is the Undergoer, the verb takes *poN-*. When something other than the endpoint is the Undergoer (a material theme in (86a)), the prefix is *po-*.

Kroeger mentions a number of verbs which allow this alternation, including 'give', 'throw' and 'split'. In the latter case, the Undergoer can be an instrument, similar to the instrument advancement proposed for Malagasy. For instruments, the reading is one of adversely affected; the implication is that the action will be harmful to the instrument. Hence, the instrument is the primary affected object in the Undergoer position. Kimaragang Dusun therefore resembles English: the direct argument, whatever its role, is the affected argument.

6.2 Malagasy

In contrast to English and Kimaragang, the different positions of DPs in the Malagasy alternations do not affect the affectedness interpretation. I will show that in the locative alternation only one argument (the goal) is interpreted as the affected object. With dative shift verbs, however, both the theme and the goal are affected. I will argue that this difference between the verbs stems from independent properties of the roots of these verbs.

In order to test for affectedness and telicity, we need some background on aspect in Malagasy. As discussed in detail by Phillips (in

press), most verbs in Malagasy are non-telic: the end result is implied but not entailed. In other words, although (87a) is most often used in situations where the dog is in fact captured by the child, it is possible to negate this implication, as in (87b).

- (87) a. Nisambotra ny alika ny zaza...
 pst.AT.catch det dog det child
 ‘The child caught the dog...’
- b. ... nefa faingana loatra ilay alika.
 but quick too def dog
 ‘... but the dog was too quick.’

In order to make the verb telic, a different active prefix is used: *aha-*. With *aha-*, the end result is entailed. Hence (88a) cannot felicitously be followed by (88b).

- (88) a. Nahasambotra ny alika ny zaza...
 pst.aha.catch det dog det child
 ‘The child caught the dog...’
- b. # ... nefa faingana loatra ilay alika.
 but quick too def dog
 ‘... but the dog was too quick.’

The above data indicate that in order to investigate telicity, it is first necessary to use the prefix *aha-*. In other words, it is not the nature of the object DP that determines telicity in Malagasy, in contrast to English. Instead, it is the verbal prefix which forces a telic reading, similar to perfective verbal affixes in Slavic languages (see Wierzbicka (1968) on Polish). How, then, to test for affected objects? I will refer to the element that undergoes the change of state entailed by the verb as the affected object. In other words, I am using the term “affected object” in a very narrow sense. Due to the connection between telicity and affectedness in

Malagasy, in what follows, I use telic verbs to test for affected objects.⁵⁵

6.2.1 *Locative alternation*

Let us now look at the locative alternation in Malagasy. Whether the material theme appears in the direct object position (89) or in a PP (90), the interpretation remains unchanged: the water need not be “wholly affected” by the action of filling.

(89) a. Nahafeno ny rano tao anatin’ny tavoahangy ny sinibe
 pst.aha.full det water pst.there in.gen.det bottle det pitcher
 Rabe ...
 Rabe
 ‘Rabe filled the water in the bottle into the pitcher.’

b. ... nefa mbola misy rano tavela ao
 but still AT.have water left there
 anatin’ily tavoahangy.
 in.gen.def bottle
 ‘... but there is still water left in the bottle.’

(90) a. Nahafeno ny sinibe tamin’ny rano tao anatin’ny
 pst.aha.full det pitcher pst.P.gen.det water pst.there in.gen.det
 tavoahangy Rabe...
 bottle Rabe
 ‘Rabe filled the pitcher with water in the bottle.’

⁵⁵ Since *aha-* verbs are unambiguously telic, they are compatible only with the equivalent of ‘in an hour’, independent of the quantitative nature of the NPs.

(i) a. Nahafeno rano ny tavoahangy tao anatin’iray ora Rabe.
 pst.aha.full water det bottle pst.there in.gen.one hour Rabe
 ‘Rabe filled water into the bottle in one hour.’
 b. * Nahafeno rano ny tavoahangy nandritran’iray ora Rabe.
 pst.aha.full water det bottle during.gen.one hour Rabe
 ‘Rabe filled water into the bottle for one hour.’

The judgements in (i) are not changed if the arguments appear in the NP-PP order. Therefore, the temporal adverbial test is not applicable.

- b. ... nefa mbola misy rano tavela ao
 but still AT.have water left there
 anatin'ilay tavoahangy.
 in.gen.def bottle
 '... but there is still water left in the bottle.'

Since a change of state in the material theme is not entailed, I conclude that material themes are not affected, whatever their syntactic position. In other words, [Spec, v2P] (the position for material themes) is not associated with affectedness.

On the other hand, the goal is interpreted as affected, either as a secondary object (91) or direct object (92).

- (91) a. Nahafeno rano ny tavoahangy Rabe ...
 pst.aha.full water det bottle Rabe
 'Rabe filled water into the bottle.'
- b. # ... nefa mbola misy toerana azo anasivana rano
 but still AT.have place able CT.put water
 ilay tavoahangy.
 def bottle
 '... but there is still room to put water into the bottle.'
- (92) a. Nahafeno ny tavoahangy tamin'ny rano Rabe ...
 pst.aha.full det bottle pst.P.gen.det water Rabe
 'Rabe filled the bottle with water....'
- b. # ... nefa mbola misy toerana azo anasivana rano
 but still AT.have place able CT.put water
 ilay tavoahangy.
 def bottle
 '... but there is still room to put water into the bottle.'

The above data indicate that the verb *mahafeno* 'fill' is indeed telic, but that only the end result of the bottle being full is entailed. The results in (89)-(92) are the same with all the locative alternation verbs (e.g. *mahatototra*

‘fill’, *maharakotra* ‘cover’, etc.).⁵⁶

Summing up, the locative alternation in Malagasy is not associated with any changes in meaning that have been noted for languages like English and Kimaragang Dusun. Only the goal is an affected object, whether or not it is adjacent to the verb. I now turn to datives, which differ from the locative alternation.

6.2.2 Dative shift

Let us now consider the other large class of verbs that have two passives: dative verbs. The data in (93) indicate that for these verbs, the theme is interpreted as an affected object.⁵⁷

- (93) a. Naharoso ny vary tao anatin’ny vilia hoan’ny
 pst.aha.serve det rice pst.there in.gen.det plate to.gen.det
 ankizy ny mpiasa...
 child det worker
 ‘The workers served the rice in the dish to the children...’
- b. # ... nefa mbola misy vary tavela.
 but still AT.have rice left
 ‘... but there is still some rice left over.’

Similarly, the goal is affected, whether realized as a DP or PP.

- (94) a. Naharoso (ny) vary ny ankizy ny mpiasa...
 pst.aha.serve (det) rice det child det worker
 ‘The workers served the children rice...’
- b. # ... nefa tsy ampy ilay vary.
 but neg enough def rice
 ‘... the rice wasn’t sufficient.’

⁵⁶ Instrumental advancement verbs also pattern this way. This is less surprising as one is hard pressed to imagine just how an instrument could get “used up” to measure out the event. Malagasy thus does not have the “adversely affected” reading associated with advanced instruments in Kimaragang Dusun.

⁵⁷ (93b), (94b) and (95b) all remain impossible if *nefa* ‘but’ is replaced by *ka* ‘and’.

- (95) a. Naharoso (ny) vary hoan'ny ankizy ny mpiasa...
 pst.aha.serve (det) rice to.gen.det child det worker
 'The workers served the rice to the children...'
- b. # ... nefa tsy ampy ilay vary.
 but neg enough def rice
 '... the rice wasn't sufficient.'

For dative verbs, both the theme and the goal are affected arguments.

In section 6.2.1, I showed that with locative alternation verbs, there is only one affected object. The above data indicate that with dative verbs, there are two.

(96) affected object

	locatum	goal
locative alternation	no	yes
dative shift	yes	yes

What might account for this difference? In what follows, I argue that it stems from differences between the roots that these verbs are built from.

6.2.3 *On the importance of roots*

With very few exceptions, all active verbs in Malagasy are built from roots. These roots are either adjectival or nominal in nature and often can be the matrix predicate of a clause. Interestingly, the split in affected arguments I noted between locative alternation and dative shift is paralleled by another difference at the level of the root. In particular, I will show that the element that can be the external argument of the root is interpreted as the affected object of the *aha* verb.

For locative alternation verbs, only the goal may be the external argument of the root.

- (97) a. Feno (rano) ny sinibe.
 full (water) det pitcher
 'The pitcher is full (of water).'

Chapter 2

- b. * Feno (ny sinibe) ny ranjo.
full (det pitcher) det water
- (98) a. Fatatra (vary) ny kitapo.
stuffed (rice) det bag
'The bag is stuffed (with rice).'
- b. * Fatatra (ny kitapo) ny vary.
stuffed (det bag) det rice

As shown by the ungrammaticality of (97b) and (98b), the material theme cannot be the external argument of the root.

In contrast, dative verbs allow either the theme or the goal as the external argument of the root. (As mentioned earlier, with most dative verbs the goal is optional and the theme is obligatory.)

- (99) a. Roso (ny ankizy) ny vary.
served (det child) det rice
'The rice is served (to the children).'
- b. Roso vary ny ankizy.
served rice det child
'The children are served rice.'
- (100) a. Toro (ny mpandeha) ny lalana.
pointed-out (det traveller) det road
'The road is pointed out (to the travellers).'
- b. Toro lalana ny mpandeha.
pointed-out road det traveller
'The travellers are pointed out the road.'

Thus we have the following distinction between locative alternation roots and dative roots.

(101) external argument of root

	locatum	goal
locative alternation	no	yes
dative shift	yes	yes

Comparing the table in (101) with the one in (96), we see that there is a correlation between the external argument of the root and the affected object. I therefore suggest that it is the external argument of the root that undergoes the change of state in a telic verb.⁵⁸ In other words, at the level of the root affectedness relations are determined and are not changed by the different positions where elements are generated. Clearly, however, the change of state reading for the affected object is not always present, as in active verbs mentioned at the beginning of this section. Different verbal affixes (e.g. *aha*) are necessary to realize the change of state encoded by the root.

6.2.4 Further data

Above, I have claimed that the resulting end state is encoded lexically by the root. For locative alternation verbs, it is the goal that undergoes a change of state. For dative verbs, it is both the theme and the goal. Is this difference due to some underlying semantic distinction between the two types of verb? In other words, is there something inherent about dative verbs as a class that allows them to have two different external arguments? I suggest that this is not the case. Instead, the only test for affected object is the one given above: which element can appear as the external argument of the root. Evidence comes from a locative alternation verb *mahafafy* 'sow', which patterns with dative verbs for both affectedness and at the root level.

As shown by the examples below, either the material theme or the goal may be the external argument of the root *fafy* 'sown'.

⁵⁸ It is not clear at what level of representation affectedness is encoded. Moreover, at the level of argument structure, certain roots (e.g. datives) appear to have two external arguments. Under standard assumptions (e.g. Williams (1981)), only a single external argument is possible for a lexical entry. Positing two different lexical entries for these roots opens up the question of why the telic verb has two affected arguments simultaneously.

Chapter 2

(102) a. Fafy ny voa.
sown det seed
'The seeds are sown.'

b. Fafy ny saha.
sown det field
'The field is sown.'

Following the reasoning in the preceding sections, I would expect both the material theme and the goal to be affected objects. This is in fact the case. When the verb bears the *aha* active prefix, both the material theme and the goal are interpreted as reaching the end state described by the verb.

Let us first consider the goal. The results are not so surprising as they pattern with verbs like *mahafeno* 'fill'. In other words, the goal is interpreted as affected by the action of sowing.

(103) a. Nahafafy ny saha tamin'ny voa tao
pst.aha.sow det field pst.P.gen.det seed pst.there
anatin'ny kitapo ny mpamboly...
in.gen.det bag det farmer
'The farmer sowed the field with the seeds in the bag...'

b. # ... nefa tsy ampy ilay voa.
but neg enough def seed
'...but the seeds were not sufficient.'

(104) a. Nahafafy ny voa tao anatin'ny kitapo ny saha
pst.aha.sow det seed pst.there in.gen.det bag det field
ny mpamboly...
det farmer
'The farmer sowed the seeds in the bag in the field...'

b. # ... nefa tsy ampy ilay voa.
but neg enough def seed
'...but the seeds were not sufficient.'

Turning now to the material theme, we see that it must be completely used up by the action of sowing when it is realized as a DP. Hence it is an affected object. This is a surprising result when *mahafafy* is compared with other locative alternation verbs such as *mahafeno* ‘fill’, where the material theme is never an affected object (see examples (93) and (94) in section 6.2.1).

- (105) a. Nahafafy ny voa tao anatin’ny kitapo ny saha
 pst.aha.sow det seed pst.there in.gen.det bag det field
 ny mpamboly...
 det farmer
 ‘The farmer sowed the seeds in the bag in the field...’
- b. # ... nefa mbola misy voa tavela ao anatin’ily kitapo.
 but still AT.have seed left there in.gen.def bag
 ‘...but there are still seeds left in the bag.’

When the material theme surfaces as a PP, however, it is not affected, as shown by the data in (106).

- (106) a. Nahafafy ny saha tamin’ny voa tao
 pst.aha.sow det field pst.P.gen.det seed pst.there
 anatin’ny kitapo ny mpamboly...
 in.gen.det bag det farmer
 ‘The farmer sowed the field with the seeds in the bag...’
- b. ... nefa mbola misy voa tavela ao anatin’ily kitapo.
 but still AT.have seed left there in.gen.def bag
 ‘...but there are still seeds left in the bag.’

To account for the difference between (106) and (105), I suggest that only arguments can be affected. In (106), the material theme is in an adjunct position, as argued in section 2.3. Therefore, we do not expect the material theme to act as an affected object in this position. Importantly, *mahafafy* ‘sow’ provides further evidence in support of the correlation between the external argument of a root and the affected argument of the

telic verb.

A range of data indicate that the DP that appears as the external argument to a root is the argument that undergoes the change of state. This change of state is realized when the telic prefix *aha* is used. There are no interactions with the quantitative nature of the DPs in these alternations. Moreover, word order does not change the affectedness relations encoded by the root. The only cases where word order does have an effect is when an element (e.g. a material theme) is realized in an adjunct position. As an adjunct, a material theme can not be interpreted as affected, not a surprising result. In sum, [Spec, v2P] is not an affected argument position. In other words, affectedness in Malagasy is lexically rather than structurally determined. Further, the data in this section illustrate the importance of roots in the syntax of Malagasy. The root encodes information that is only realized when certain affixes are added.⁵⁹

7 Conclusion

The focus of the present chapter has been passive constructions. I have argued that different passive affixes target distinct structural positions. The passive data have provided evidence in favour of a structural position, [Spec, v2P], between the positions for agent and other internal arguments of the verb. In Malagasy, only certain arguments may be generated in [Spec, v2P]. Drawing on a range of data from three argument verbs, I have shown that this position is for locata or displaced themes.

In the following subsections, I discuss possible extensions of this line of research.

7.1 Passive

The above analysis draws on a classical GB view of passive: unavailability of Case forces DP movement. My analysis crucially requires that only those DPs that are not marked for Case can raise to subject. In other words, the head that drives movement to subject position (e.g. T°) cannot attract any Case-marked DPs in the structure.⁶⁰ In an active clause, the internal arguments of a transitive verb are assigned Case; the external argument must raise to get nominative Case. In passives, the different

⁵⁹ Phillips (in press) comes to a similar conclusion in her study of the *aha* affix.

⁶⁰ See chapter 3, section 5 for some discussion of the features that motivate subject movement.

affixes signal the loss of Case to different structural positions. For example, in the *-Vna* passive of a dative verb, accusative Case is not available in VP and the goal raises over the Case-marked theme and agent.

While in English, passive can be used to promote various arguments, Malagasy signals the different arguments with different affixes. Some researchers take this to indicate that voice in Austronesian languages is a type of “theta agreement”. Despite the attractiveness of this approach, we have already seen that it runs into problems with Malagasy passives. The *-Vna* passive, for example, promotes themes and goals. Thus there is no one-to-one mapping between theta role labels and voice affixes.⁶¹ The analysis proposed in this chapter posits a basic split between the two passive affixes. On one hand, the *a-* passive promotes arguments in a particular position, [Spec, v2P]. On the other hand, the *-Vna* passive promotes arguments in a particular domain, the lower VP. Further research will determine whether both types of passive (position and domain) are available cross-linguistically and the constraints on their distribution.

7.2 [Spec, v2P]

Matsuoka (1999) proposes for a very similar analysis to the one presented in this chapter for certain dative arguments in Japanese. He argues for a base generated position for a subset of dative-marked arguments. For Matsuoka as well as for me, this position is between the agent and the theme. He discusses the following alternations.

- (107) a. John-ga hon-o Mary-ni wasas-ta.
 John-nom book-acc Mary-dat pass-pst
 ‘John passed a book to Mary.’
- b. Mary-ga John-ni penki-o abise-ta.
 Mary-nom John-dat paint-acc pour-pst
 ‘Mary poured paint over John.’

⁶¹ Theta agreement will be discussed again in the next chapter, in the context of circumstantial topic.

Chapter 2

Matsuoka proposes that with ‘pass’-type verbs (107a), the dative argument is a goal and generated below the accusative theme. For ‘pour’-type verbs (107b), on the other hand, the dative argument is generated between the agent and the theme (he calls this dative a “possessor”).

In support of his analysis, Matsuoka shows that with ‘pass’-type verbs, only the theme can be the subject in an inchoative construction.

(108) a. Hon-ga Mary-ni wasas-ta.
book-nom Mary-dat pass-pst
‘The book passed to Mary.’

b. * Mary-ga hon-o watar-ta.
Mary-nom book-acc pass-pst

Interestingly, with ‘pour’-type verbs, only the dative argument can be the subject of the inchoative verb.

(109) a. John-ga penki-o abi-ta.
John-nom paint-acc pour-pst
‘John got paint poured over him.’

b. * Penki-ga John-ni abi-ta.
paint-nom John-dat pour-pst

Matsuoka follows Baker (1996a) and argues that this difference stems from the different structural positions of the dative arguments in each type.

Further crucial data in support of Matsuoka’s analysis come from quantifier scope interactions. Unfortunately, the parallel Malagasy data are far from clear. For independent reasons, the only way to test for scope asymmetries is with bound pronouns. As shown in (110a), a DP goal can bind a DP theme. On the other hand, (110b) indicates that a goal cannot bind out of a PP.

- (110) a. Nanolotra ny bokiny ny mpianatra rehetra i Ketaka.
 pst.AT.offer det book.3(gen) det student every Ketaka
 ‘Ketaka offered his book to every student.’
- b. ?? Nanolotra ny bokiny hoan’ny mpianatra rehetra i Ketaka.
 pst.AT.offer det book.3(gen) for.det student every Ketaka
 ‘Ketaka offered his book to every student.’

Further data, however, cast doubt on this conclusion. Instead, there is something “funny” about PPs in these structures that blocks binding both into and out of them. (111a) illustrates binding of a DP goal by a DP theme. Binding is not possible when the goal is a PP, as shown by (111b).

- (111) a. Nanolotra ny boky rehetra ny tompony i Ketaka.
 pst.AT.offer det book every det owner.3(gen) Ketaka
 ‘Ketaka offered every book to its owner.’
- b. ?? Nanolotra ny boky rehetra hoan’ny tompony i Ketaka.
 pst.AT.offer det book every for.det owner.3(gen) Ketaka
 ‘Ketaka offered every book to its owner.’

Moreover, there is much variation in judgements both within and across speakers. I therefore leave binding for further research. Nevertheless, looking at parallels between the Malagasy and Japanese data, I conclude that Universal Grammar allows for a special position, [Spec, v2P]. Languages differ as to which elements may be generated in this position.

In this chapter, I argue that in Malagasy [Spec, v2P] is restricted to certain elements, roughly displaced themes or locata. In Japanese, this position hosts dative “possessors”. At the same time, [Spec, v2P] is not simply an open position. As discussed above, base generation implies a restricted phenomenon. Interestingly, since [Spec, v2P] is structurally superior to themes, this position can obscure theta-hierarchy effects. For example, if goals can be base generated in [Spec, v2P], they can appear to act “higher” than themes. Most researchers acknowledge the difficulty of determining the hierarchy of VP-internal arguments. For example, although Collins and Thráinsson (1996) assume that goals c-command

themes in Icelandic, they point out that this could be the result of syntactic movement. I leave it for future work to determine just which arguments may appear in [Spec, v2P] cross-linguistically.

7.3 *Lexical semantics*

In section 4.2, I briefly mentioned that a lexical semantic study will shed further light on the alternations discussed in this chapter. The connection between argument structure and syntactic structure that I am arguing for here is similar to the one presented in Rappaport and Levin (1988). According to my analysis, the alternating verbs have two distinct but related underlying lexical semantic representations. This lexical conceptual structure (LCS) then maps to predicate argument structures (PAS). There are linking rules that determine which variables are linked to which positions. I believe that the Malagasy verbs discussed in this chapter all share a similar LCS, probably encoding a change of location. In other words, all these verbs have the substructure in (112).⁶²

(112) [x come to be at LOCATION] ...

A linking rule then states that verbs with this change of location component allow the “locata” (*x*) to be realized as a direct DP argument. Passive is sensitive to the syntactic structure that is projected from the LCS. The locative alternation and instrumental advancement verbs also have a different LCS, where the material theme and instrument are represented in a MEANS clause and are syntactically realized as adjuncts. The details of this approach I leave for further research.

7.4 *TT vs. CT*

In all the passive constructions discussed above, I have shown that DP arguments move to subject position for nominative. Apparent counterexamples, such as the passives of instrumentals, were shown to involve base generation of the “adjunct” in an argument position. We are now in a position to contrast passive with CT, which does not promote DP arguments and instead is used for adjuncts, PPs and other non-structurally Case marked DPs. CT is therefore the topic of the next chapter.

⁶² Or, as suggested by Pearson (1998a):

(i) ... [x GO TO y]...

Chapter 3: Circumstantial Topic

1 Introduction

In chapter 1, I briefly discussed the notion of voice alternations. I pointed out that although many languages show a two-way alternation (e.g. active-passive), Malagasy enjoys a three-way voice system: active-passive-circumstantial. In chapter 2, I discussed the nature of passive and briefly contrasted it with the circumstantial (CT). In this chapter, I address the syntax of the circumstantial voice. What is of interest is that in circumstantial clauses, a wide range of elements appear in subject position. It is the goal of this chapter to characterize the nature of these elements and hence to provide a unified analysis of CT.

To begin, consider the standard voice alternation given in chapter 1, repeated below.¹

- (1) a. Nanapaka ity hazo ity tamin'ny antsy i Sahondra.
pst.AT.cut this tree this pst.P.gen.det knife Sahondra
'Sahondra cut this tree with the knife.'
- b. Notapahin'i Sahondra tamin'ny antsy ity hazo ity.
pst.TT.cut.gen.Sahondra pst.P.gen.det knife this tree this
'This tree was cut by Sahondra with the knife.'
- c. Nanapahan'i Sahondra ity hazo ity ny antsy.
pst.CT.cut.gen.Sahondra this tree this det knife
'The knife was used by Sahondra to cut the tree.'

In the previous chapter, we saw that Theme Topic (TT) covers a wide range of passive-like constructions. Nevertheless, I argued that all passives in Malagasy involve promotion to subject of a DP argument, never an adjunct, never a PP. We also saw that elements (e.g. instruments) that can be realized either as DPs or PPs are promoted to subject either with TT or Circumstantial Topic (CT). I showed that in these cases, TT promotes DPs, while CT promotes PPs. I did not, however,

¹ In this chapter, I will gloss the various passive forms as TT.

offer an analysis of CT to capture this observation.

What is CT? It is difficult to arrive at a precise characterization of the elements that are promoted to subject with CT. Some researchers focus on the function of the CT subject. For example, Rajemisa-Raolison (1966) claims that some “circumstance” of the action becomes the grammatical subject (hence the label “Circumstantial Topic”). Along similar lines, under a theta-agreement analysis of voice (e.g. Sityar (in press)), CT would be adjunct agreement. Others take the underlying form of the CT subject to be crucial. Keenan (1976) suggests that it is an element that would be marked with oblique case that is promoted. Formalizing Keenan’s idea, Guilfoyle, Hung and Travis (1992) propose that CT involves P-incorporation. These descriptions fall into two main categories, function: CT promotes adjuncts (Rajemisa-Raolison and Sityar); form: CT promotes objects of prepositions (Keenan and GHT).

Instead of treating CT as tied directly to prepositions or theta-roles, I will argue that a CT clause involves the promotion to subject of an element that is not a structurally Case-marked DP. For the most part, this will target PPs, hence the connection with prepositions. It will also include adjuncts in general, hence the appearance of theta-agreement. Unlike the passive affixes discussed in the previous chapter, CT is sensitive neither to position (cf. *a-* passive) nor to domain (cf. *-Vna* passive). In fact, we will see that CT can promote an element from almost any structural position in the clause.²

² The one position that is never associated with CT is the agent. This gap remains unexplained.

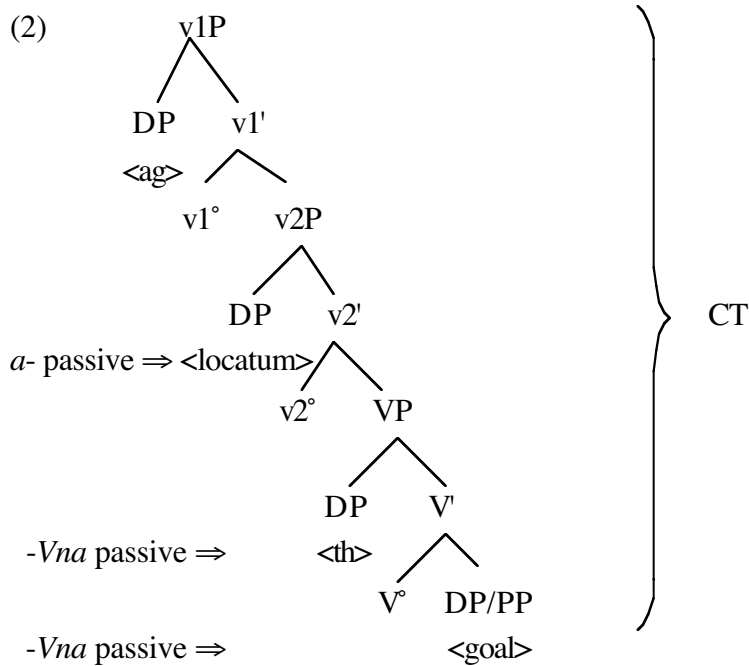

Under this view, CT in Malagasy is a kind of “elsewhere” voice and contrasts with languages such as Tagalog and Cebuano, where CT is subdivided into different types (benefactive, instrumental, locative). I will briefly discuss the Tagalog voice system in section 7.

I will begin by looking at the nature of elements that are promoted to subject with CT morphology. Since CT is quite different from voice alternations in well-known languages such as English, in section 2 I will provide a wide range of examples. Crucial will be the question of the theta-role and category of the elements targeted by CT. In the subsequent sections, I will consider two possible accounts for CT. First, I will evaluate the connection between CT and adjuncts. The discussion will touch on adjuncts in Malagasy clause-structure and tests for the argument-adjunct distinction. Drawing on data from PP arguments and partitive themes, I will show that CT promotes not only adjuncts, but also certain arguments. I therefore reject the adjunct-agreement approach. Second, I consider the link between CT and prepositions. Although many examples involve PPs, the data presented in section 2 indicate that not only the objects of prepositions are promoted to subject with CT; instead, a range of categories are involved. Hence CT is not preposition incorporation. Section 5 is devoted to the proposed analysis of CT. In section 6, I consider a special use of CT that falls outside most accounts of

CT. I will show, however, that my analysis easily captures this unusual construction. In section 7, I briefly consider the equivalent of CT in Tagalog before concluding in section 8.

2 CT clauses

Let us now turn to the distribution of CT clauses. As mentioned at the beginning of this chapter, in a CT clause it is often an adjunct that is promoted to subject. I will now explore the range of elements that can be promoted. We will see that although adjuncts are indeed prevalent as CT subjects, certain arguments may be promoted to subject with CT. A secondary goal will be a discussion of the cleft. Many CT clauses have the form of a cleft construction. I will show that the category of the promoted element determines whether it can be a subject or must appear in a cleft. In other words, restrictions on the subject position account for obligatory clefts.

2.1 The core data

In his grammar of Malagasy, Rajemisa-Raolison (1966) lists the range of elements that can be promoted via CT: place, time, goal, cause, means, manner, instrument, price, benefactive, locative, etc. Some illustrative examples appear in (3).

- (3) a. instrument
Anapahany bozaka ny_antsiny.
CT.cut.3(gen) grass det knife.3(gen)
'Her knife is used by her to cut grass.'
- b. locative adverbial
Itoeranay ity_trano...ity.
CT.live.1pl(gen) this house this
'This house is lived in by us.'
- c. causal adverbial
[Noho ny andro alina] no odiako haingana.
because det day night foc CT.go-home.1sg(gen) quickly
'It's because it is getting late that I am going home quickly.'

- d. temporal adverbial
 [Tamin'ny zoma] no nividianako vary.
 pst.P.gen.det Friday foc pst.CT.buy.1sg(gen) rice
 'It's on Friday that I bought rice.'

Yet not all of these CT clauses act the same. As in the examples above, some circumstantial clauses are clefts while others are not.³ In fact, while (3a,b) have the option of being expressed as a cleft, (3c,d) are examples of obligatory clefts.⁴ This difference is illustrated in (4).

- (4) a. [Ny antsiny] no anapahany bozaka.
 det knife.3(gen) foc CT.cut.3(gen) grass
 'It's her knife that is used by her to cut grass.'
- b. [Ity trano ity] no itoeranay.
 this house this foc CT.live.1pl(gen)
 'It is this house that is lived in by us.'
- c. * Nodiako haingana noho.....ny andro alina.
 pst.CT.go-home.1sg(gen) quickly because det day night
 'I went home quickly because it was getting late.'
- d. * Nividianako vary tamin'ny zoma.
 pst.CT.buy.1sg(gen) rice pst.P.gen.det Friday
 'I bought rice on Friday.'

The grammaticality of (3a,b) and (4a,b) shows that both locatives and instruments can be either in the subject position subjects or in a CT cleft.

³ Crucially, the "gap" in the clause corresponds to the subject position. Thus although these elements cannot surface as clause-final subjects, they nevertheless have been promoted with CT. See section 2.4 for more discussion of clefts.

⁴ On the surface, obligatory clefting is reminiscent of the fact that CT-like constructions in some western Austronesian languages only surface in extraction contexts (e.g. Tagalog: Foley (1976)). In other words, the equivalent of CT is not used in simple clauses, but only when "necessary" for A-bar movement (e.g. relativization, *wh*-questions, etc.). I believe there is a difference, however. In Malagasy, clefting is truly obligatory for PPs, while the markedness of CT-like voices in other languages is not ungrammaticality. In fact, Malagasy grammarians point out that CT verbs are most often used as noun modifiers (Malzac (1960); Rahajarizafy (1960); Rajemisa-Raolison (1966)). This appears to be the same pragmatic (not grammatical) restriction as in Tagalog.

Causal and temporal adverbials, however, cannot be subjects and are therefore clefted, as illustrated by the contrast between (3c,d) and (4c,d). With CT clauses, therefore, several questions arise. Which elements are promoted? What theta roles and categories are involved? Which elements may appear in the clause-final subject position and which must be clefted? This section will be devoted to answering these questions. Once these questions are addressed, we will be in a position to assess the various analyses of CT that have been proposed.

2.2 Targets

If we take voice morphology as “targeting” elements to be promoted, we can ask: what is the target of a particular voice? For the *a-* passive, for example, I suggested in chapter 2 that the target is the element in [Spec, v2P]. For CT, we have just seen that the range is quite wide, including different adjunct-like roles (locative, temporal, instrumental, etc.). These adjuncts arguably occupy different positions in the clause: some adjoined to VP, others to IP (see, for example, Jackendoff (1972); Travis (1988) on adverbs). Moreover, as we will see in the following examples, the category of these elements varies widely.

Quite commonly, the element promoted to subject in a CT clause originates as the object of a preposition. The (a) examples below illustrate the base position of the element that is the subject of the CT clause in the (b) counterparts. (5) is a locative and (6) is a goal.

- (5) a. Mitoetra [pp amin’ity trano ity] ry Ratsimba.
 AT.live P.gen.this house this det Ratsimba
 ‘The Ratsimbias live in this house.’
- b. Itoeran-dry Ratsimba ity trano ity.
 CT.live.gen.det Ratsimba this house this
 ‘This house is lived in by the Ratsimbias.’
- (6) a. Nandroso vary [pp hoan’ny vahiny] Rakoto.
 pst.AT.serve rice for.gen.det guest Rakoto
 ‘Rakoto served rice to the guests.’

- b. Nandrosoan-dRakoto vary ny.yahiny.
pst.CT.serve.gen.Rakoto rice det guest
'The guests were served rice by Rakoto.'

The following illustrate categories other than PP: adverbs (often of adjectival status), CPs, VPs and DPs.⁵ (Note that all of these examples are clefted; I will address this issue directly below.)

- (7) a. Miteny mafy iBozy.
AT.speak hard Bozy
'Bozy speaks loudly.'
- b. [_{adv} Mafy] no itenenan'i Bozy.
hard foc CT.speak.gen.Bozy
'It's loudly that Bozy speaks.'
- (8) a. Mianatra mafy aho mba hahazo karama be.
AT.study hard 1sg(nom) opt fut.AT.get salary big
'I'm studying hard to earn a big salary.'
- b. [_{CP} Mba hahazo karama be] no ianarako mafy.
opt fut.get salary big foc CT.study.1sg(gen) hard
'It's in order to earn a big salary that I'm studying hard.'
- (9) a. Mitsangana mihinana akoho Rahe.
AT.stand AT.eat chicken Rabe
'Rabe stands while eating chicken.'
- b. [_{VP} Mihinana akoho] no itsanganan-dRabe.
AT.eat chicken foc CT.stand.gen.Rabe
'It's while eating chicken that Rabe stands.'

⁵ In certain cases, it is difficult to determine the category of the clefted XP. In (9b), for example, the clefted XP could be a DP rather than a VP (zero nominals are very common in Malagasy). Nevertheless, the examples in (7) - (10) do illustrate a range of categories.

Chapter 3

- (10) a. Tonga io maraina io izy.
arrived this morning this 3(nom)
'She arrived this morning.'
- b. [DP Io maraina io] no nahatongavany.
this morning this foc pst.AT.arrive.3(gen)
'It's this morning that she arrived.'

In all the above examples, although of varying category, the elements promoted to subject correspond to adverbial modifiers, similar to the English translations. At first glance, therefore, the adjunct-agreement analysis of CT appears attractive. I will consider this analysis in more detail in section 3 and show that it is untenable, however. The data also illustrate that CT does not target elements of a single category. This range of categories will become important in section 4. Category will also determine whether an element may be a subject, a question which I address in the following section.

Before concluding this section, however, I point out a somewhat exceptional use of CT.

- (11) Anasan-dRakoto amin'ny savony ny lovia.
CT.wash.gen.Rakoto P.gen.det soap det dishes
'Rakoto washes some of the dishes with the soap.'

(11) is exceptional in two respects. First, the theme of the verb (*ny lovia* 'the dishes') appears in subject position, but the verb bears CT morphology, not TT. Second, this subject DP is interpreted as partitive ('some of the dishes'), a reading not normally available for subjects. For this reason, I refer to examples like (11) as Exceptional Circumstantial Topic Marking (ECTM). One of the challenges will be to integrate ECTM into an analysis of CT. In section 6, I provide a thorough analysis of ECTM.

2.3 Subjects

We can now turn to the question of which elements appear in the clause-final subject position. As mentioned in chapter 1, Malagasy subjects must

be specific DPs.⁶ This restriction accounts for the range of permissible subjects in CT clauses. For example, PP subjects are not permitted, as shown by the ungrammaticality of (12a).⁷ This is also true when the verb is CT, as in (12b). For the preposition to co-occur with CT, the PP must be in a clefted position not the subject position, as in (12c). (See the examples in (3c,d) and (4c,d) above for a similar contrast).

- (12) a. * Maloto eo_ ambonin'ny... latabatra.
 dirty there under.gen.det table
 'Under the table is dirty.'
- b. * Anapahany bozaka amin'ny... antsiny.
 CT.cut.3(gen) grass P.gen.det knife.3(gen)
- c. [Amin'ny antsiny] no anapahany bozaka.
 P.gen.det knife.3(gen) foc CT.cut.3(gen) grass
 'It's with her knife that she cuts grass.'

Interestingly, both price and temporal DPs are barred from the subject position, but must be clefted (as DPs).

- (13) a. * Nividianany hena valopolo.
 pst.CT.buy.3(gen) meat 80
- b. [Valopolo] no nividianany hena.
 80 foc pst.CT.buy.gen.3 meat
 'It was for 80 (ariary) that she bought meat.'
- (14) a. * Nividianany hena omaly.
 pst.CT.buy.3(gen) meat yesterday

⁶ This raises the question of CP subjects. See section 2.5 for discussion.

⁷ (12a) is grammatical if the PP is preceded by a determiner. In other words, the subject in (i) is a zero nominalization, not a PP.

(i) Maloto ny eo_ ambonin'ny latabatra.
 dirty det there under.gen.det table
 'Under the table is dirty.'

- b. [Omaly] no nividianany hena.
 yesterday foc pst.CT.buy.3(gen) meat
 'It was yesterday that she bought meat.'

Extending work by Cinque (1990); Rizzi (1990), I suggest that price and temporal adverbials are non-referential. Since only specific DPs are allowed in subject position, (13a) and (14a) must be expressed with the cleft constructions in (13b) and (14b). Similar considerations apply to manner adverbs, VPs and CPs, which all fail as specific DPs and are barred from the subject position (see examples (7)-(10) above, which are all clefts). Hence the independently motivated restriction on the subject position easily accounts for certain patterns in CT clauses. As illustrated in many examples above, when an element is barred from the subject position, it surfaces in a cleft. I therefore now turn to clefts.

2.4 Clefts

We have seen that a range of elements are promoted to subject in CT clauses: PPs, adverbs, CPs, VPs, DPs. Restrictions on the subject position, however, make clefting obligatory in many cases. What is a cleft? On the surface, clefts involve a displaced element: the clefted XP is clause-initial, followed by a focus particle *no*. The structure and meaning of clefts will be discussed in detail in chapter 4. For this chapter, I simply assume the structure below.

- (15) [_{FocusP} XP_i [_{CP} OP_i [_{IP} ... ec_i ...]]]

The XP is the clefted element, which receives a focus interpretation. In chapter 4 I provide arguments that XP is in fact the main predicate and the subject is a headless relative clause. The details of this structure are not important to the current discussion, however. What is important, however, is the operator-variable relation.

Let us now consider the properties of the clefted element. In general, if what is being clefted was originally a PP, when the verb is in CT, either a DP or a PP cleft is possible (e.g. prices do not take prepositions and therefore will never surface as PPs).

- (16) [(Amin')ny antsiny] no anapahany bozaka.
 (P.gen.)det knife.3(gen) foc CT.cut.3(gen) grass
 'It's with her knife that she cuts grass.'

See below for some discussion of these two possibilities.

Complementizers, however, are never optional. For example, *mba*, an optative marker, is obligatory. Note that *mba* can only take IP complements (not DP). Thus (17a) contrasts with (17b), where the complement of *mba* is a DP.

- (17) a. Naka ity boky ity aho
 pst.AT.take this book this 1sg(nom)
 mba hampianarako anao.
 opt fut.CT.teach.1sg(gen) 2sg(nom)
 'I took this book to teach you with.'
- b. * Naka ity boky ity aho
 pst.AT.take this book this 1sg(nom)
 mba ny fampianarako anao.
 opt det nm.CT.teach.1sg(gen) 2sg(nom)

In (17b), I have used the *f*-nominalization (glossed *nm*) of the CT verb in (17a) (Paul (1996b); Hanitriniaina and Travis (1998)). These derived nominals are event nominals and hence in principle are compatible with the meaning of *mba*. The ungrammaticality of (17b) is therefore purely due to selectional restrictions.

Supporting data come from another prepositional-like element, *noho* 'because'. Unlike *mba*, *noho* is compatible both with IP and DP complements.

- (18) a. Tsy afaka handeha any Ambositra i Koto
 neg free fut.AT.go there Ambositra i Koto
 noho [IP izy mbola kely taona loatra].
 because 3(nom) still small year too
 'Koto cannot go to Ambositra because he is still too young.'

- b. Nandositra izy noho [NP ny tahony].
 pst.AT.flee 3(nom) because det fear.3(gen)
 ‘He fled because of his fear.’

When it takes an IP, *noho* acts like a complementizer and cannot be omitted. When it takes a DP, *noho* patterns with prepositions and is optional in the cleft position. This difference is illustrated in (19).

- (19) a. [*(Noho) izy mbola kely taona loatra]
 because 3(nom) still small year too
 no tsy afahan’i Koto handeha any Ambositra.
 foc neg CT.free.gen.Koto fut.AT.go there Ambositra
 ‘It is because he is still too young that Koto can’t go to Ambositra.’
- b. [(Noho) ny tahony] no nandositra.
 (because) det fear.3(gen) foc pst.AT.flee 3(nom)
 ‘It is because of his fear that he fled.’

As we will see in section 2.5, the behaviour of CP adjuncts remains unclear. I therefore leave the non-omissibility of C° as a stipulation. Prepositions, on the other hand, are always optional in the cleft position.

I now look more closely at some restrictions on the cleft construction itself. In this section, I will examine the range of operator-variable constructions that are available in clefts, with a focus on adjuncts. I will show that certain restrictions on clefts can be derived quite simply by requiring the category of XP and the operator to match.

2.4.1 AT clefts

Recall that when the verb bears active morphology clefting is restricted to subjects and adjuncts. The data in (20) show that internal arguments of the verb, whether DP or PP, cannot be AT clefted.

- (20) a. * [Mpianatra] no mikapoka isan’andro Rabe.
 student foc AT.hit each.day Rabe
 ‘It’s students that Rabe hits every day.’

- b. * [Hoan'ny ankizy] no nanolotra mofo Raso.
 for.gen.det child foc pst.AT.offer bread Raso
 'It's to the children that Raso offers bread.'

I will take this ban on the clefting of internal arguments as a fact about Malagasy grammar and not attempt an explanation. Descriptively, VP is a barrier to A-bar extraction. For one formal account of extraction restrictions, see Nakamura (1996).

On the other hand, AT clefting of adjuncts is in general possible. This is true for locative, temporal, and instrumental adverbials, as illustrated below.⁸

- (21) a. [Tao aorian'ny mpampianatra] no nipetraka aho.
 pst.there after.gen.det teacher foc pst.AT.sit 1sg(nom)
 'It's behind the teacher that I sat.'
- b. [Taorian'ny mpampianatra] no niteny aho.
 pst.after.gen.det teacher foc pst.AT.speak 1sg(nom)
 'It's after the teacher that I spoke.'
- c. [Amin'ny penina] no manoroatra aho.
 P.gen.det pen foc AT.write 1sg(nom)
 'It's with a pen that I write.'

The data in (21) show that AT clefting is possible with a broad range of adjuncts. I therefore conclude that AT clefting of adjuncts (as opposed to arguments) is not ruled out by constraints on movement and now turn to some restrictions on what can appear in a cleft.

When an adjunct appears in an AT cleft, the preposition (if there is one) must be overt. Examples (22a,b) below are parallel to (21b,c) above but are ungrammatical due to the missing preposition.

⁸ There is some variation in judgements with benefactives. This may be due to the fact that they are marked with the same preposition as goals and hence pattern with arguments.

(i) ? [Hoan'ny ankizy] no mividy mofo aho.
 for.gen.det child foc AT.buy bread 1sg(nom)
 'It's for children that I buy bread.'

Chapter 3

- (22) a. * [Ny mpampianatra] no niteny aho.
 det teacher foc pst.AT.speak 1sg(nom)
 ‘It’s after the teacher that I spoke.’
- b. * [Ny penina] no manoroatra aho.
 det pen foc AT.write 1sg(nom)
 ‘It’s with a pen that I write.’

Following Williams (1980), I suggest that the focussed element and the operator must agree in categorial features. In (22), the operator has P features, but the focussed element is a DP. (23) gives a schematic representation of the examples in (22).

- (23) * DP [OP_{PP} ... AT.verb ... t_{PP} ...]
 └─┬─┘
 ↑

This mismatch leads to ungrammaticality.

Interestingly, the matching requirement explains why the restrictions on relativization hold strictly: only a subject can be relativized. Thus while clefting applies freely to subjects and adjuncts, for an adjunct to be the head of a relative clause, the verb must bear CT morphology.

- (24) a. * ny antony izay nandeha Rakoto
 det reason rel pst.AT.go Rakoto
 ‘the reason that Rakoto left’
- b. ny antony izay nandehanan-dRakoto
 det reason rel pst.CT.go.gen.Rakoto
 ‘the reason that Rakoto left’

Since the head of the relative clause is necessarily a DP and never a PP, the ungrammaticality of (24a) is due to a mismatch, diagrammed in (25).

- (25) * [DP [OP_{PP} ... AT.verb ... t_{PP} ...]]
 └─┬─┘
 ↑

In other words, the ungrammaticality of (24a) is parallel to that of (22a,b).

Let us now turn to some cases of adjuncts that cannot cleft in the active voice (i.e. without first being promoted to subject via CT). Manner adverbs resist AT clefts.⁹

- (26) a. * [Haingana] no milomano i.Soa.
 quickly foc AT.swim Soa
 ‘It’s quickly that Soa swims.’
- b. * [Mafy] no miteny i.Bozy.
 hard foc AT.speak Bozy
 ‘It’s loudly that Bozy speaks.’

To account for the ungrammaticality in (26), I assume that adverbs are heads that do not project (Travis (1988)). By definition (Chomsky (1981)), an operator must bind an XP, not an X°. Therefore, it is not possible to have operator movement from an adverb position. This is illustrated schematically below.

- (27) * [adverb [OP_i [... X°_i ...]]]

As well as X° manner adverbs, Malagasy has PP manner adverbials. Since these are XPs, clefting is possible. (28) therefore contrasts with (26).

- (28) [Am-pitiavana] no manoroka an’i Koto Rasoa
 P.gen.love foc AT.kiss acc.Koto Raso
 ‘It’s with love that Raso kisses Koto.’

Importantly, all of the above adjuncts can appear in clefts when the verb bears CT voice morphology. Thus (29) and (26b) are a minimal pair.

⁹ Note that these examples do not improve with the addition of another adverb, unlike the English equivalents.

- (i) * Tena mafy no miteny i.Bozy.
 very hard foc AT.speak Bozy
 ‘It’s really loudly that Bozy speaks.’

In (i), we have one adverb head adjoined to another, still an X°, not an XP. See Heggie (1993) for a discussion of the contrast in English.

- (29) [Mafy] no itenenan'i Bozy.
hard foc CT.speak.gen.Bozy
'It's loudly that Bozy speaks.'

For adverbs, this resolves the ungrammaticality since the operator will correspond to the subject, an XP position.

- (30) [adverb [OP_i [... X^o_i ... XP_i]]]

Descriptively, the A movement of the adverb to the subject position changes the X^o to an XP. The operator then binds the XP, as illustrated in (30). The matching condition holds for operator movement and clearly does not apply between the subject and the base position of the adverb. Examples of CT clefts like (29) will be discussed further in the next section.

Summing up, I take clefting as a test that distinguishes the category of different adjuncts. In general, clefting of an adjunct is possible, with certain restrictions. These restrictions on clefting fall out directly from the matching requirement. Prepositions are obligatorily realized in the cleft position to match with the category of the operator (if it does not pass through the subject position). We have seen, moreover, that heads cannot cleft, which follows from the reasonable assumption that a variable must be an XP, not an X^o.

2.4.2 CT clefts

In the preceding section, I provided an analysis of certain restrictions on the cleft position when the verb is active. I now turn to the clefting of adjuncts when the verb bears CT morphology. Unlike in AT clefts, mismatches between the clefted XP and the operator are tolerated in CT clefts. I provide some tentative suggestions to account for this difference.

We have already seen that in contrast to AT clefts, it is generally possible for either a DP or a PP to appear in the focus position of a CT cleft. In other words, the matching requirement is not observed. The preposition is thus "optional" in some respect. Recall that I invoked an account based on a categorial mismatch to explain the obligatory presence of prepositions in adjunct clefts (example in (21) and (22), diagrammed in

(31a,b)). I still must explain what allows the mismatch in CT clauses, shown in (31d). Schematically, we have the following pattern.

- (31) a. * DP [OP_{PP} ... AT.verb ... t_{PP} ...]
 b. PP [OP_{PP} ... AT.verb ... t_{PP} ...]
 c. DP [OP_{DP} ... CT.verb ... t_{PP} ... t_{DP}]
 d. PP [OP_{PP?} ... CT.verb ... t_{PP} ... t_{DP}]

The contrast between (31a) and (31b) indicates that the category of the focussed element and the operator must match. Descriptively, (31c,d) indicate that the focussed element can reflect either the DP or PP status when the verb is CT because of the intermediate step through the subject position. This is not possible with AT, which has operator movement directly from the base PP position. Hence the obligatory matching in (31b). This difference between AT clefts and CT clefts may stem from distinctions between A and A-bar movement. It is the A movement to subject in (31c,d) that distinguishes these examples from (31a,b), which only involve A-bar movement. Descriptively, pure A-bar movement must obey the matching condition while A movement escapes this requirement. If these tentative suggestions are correct, they provide further evidence in favour of treating the subject in Malagasy as an A rather than an A-bar position (in the spirit of Travis (to appear) and contra Pearson (to appear)).

2.5 A note on CPs

I have focussed most of the discussion on DPs and PPs as they appear in clefts. I now turn to CPs, which do not pattern with other adjuncts. I will describe the distribution of CP subjects and clefts but leave a complete analysis for future work. In other words, for the remainder of this chapter, I concentrate on DP and PP adjuncts. Certain CPs appear in the subject position, while others cannot. Interestingly, those CPs which can be subjects, cannot AT cleft. CPs which are barred from the subject position, on the other hand, do undergo CT clefting.

For comparison, let us first consider CP arguments and then turn to CP adjuncts. In (32a), the complement CP has been passivized to subject,

as shown by the negative polarity placement in (32b).¹⁰ The same CP, however, is ungrammatical in the cleft position in (32c).

- (32) a. Heveriko fa handeha i Soa.
 TT.think.1sg(gen) C fut.AT.go Soa
 ‘That Soa will go is thought by me.’
- b. Tsy heveriko **intsony** fa handeha i Soa.
 neg TT.think.1sg(gen) NPI C fut.AT.go Soa
 ‘That Soa will go is no longer thought by me.’
- c. * [Fa handeha i Soa] no heveriko.
 C fut.AT.go Soa foc TT.think.1sg(gen)
 (lit.)‘It is that Soa will go that is thought by me.’

Similar facts hold for CP subjects of active verbs.

- (33) a. Mahasotra an’i Sahondra fa nanoroka.....an-dRabe i Bakoly.
 AT.annoy acc.Sahondra C pst.AT.kiss acc-Rabe Bakoly
 ‘That Bakoly kissed Rabe annoys Sahondra.’
- b. * [Fa nanoroka an-dRabe i Bakoly] no mahasotra an’i Sahondra.
 C pst.AT.kiss acc-Rabe Bakoly foc AT.annoy acc.Sahondra

These data show that a CP can appear in subject position, but not in the cleft position.¹¹ Note that if we account for the acceptability of CPs in subject position by claiming they are really DPs, we are even further from understanding the impossibility of CP clefts, as DP subjects freely occur in the cleft position.

Turning now to adjunct CPs, first note that no adjunct CP can appear in subject position.

¹⁰ Alternatively the CP in (32a,b) could be extraposed. Since I do not intend to provide an analysis for CPs, I do not explore this possibility.

¹¹ Looking at similar data from English, Stowell (1985) and Heggie (1993) account for the ban on CP clefts by stipulating that functional categories cannot antecede an operator. In today’s world of rampant functional categories, it is clear that this account must be modified.

- (34) a. * Nandehanako satria...nihinana...voankazo...manta.
 pst.CT.go.1sg(gen) because pst.AT.eat fruit unripe
- b. * Ianarako mafy m̄ba hahazo.....karama be.
 CT.study.1sg(gen) hard opt fut.AT.have salary big

What explains this restriction? We have already seen in (32a) that CPs are not in principle barred from being subjects. I leave unexplained this difference between the CP in (32a) and the ones in (34).

Second, no adjunct CPs can cleft when the verb is active. (35a) illustrates a causal adjunct and (35b) a purpose clause.

- (35) a. * [Noho izy mbola kely taona loatra]
 because 3(nom) still small year too
 no tsy afaka handeha any Ambositra i Koto.
 foc neg free fut.AT.go there Ambositra i Koto
 ‘Because he is still too young, Koto cannot go to Ambositra.’
- b. * [Mba hahazo karama be] no mianatra mafy āho.
 opt fut.AT.get salary big foc AT.study hard 1sg(nom)
 ‘It’s in order to earn a big salary that I’m studying hard.’

Since we have already seen that most adjuncts can undergo AT clefting, this is a somewhat surprising result. Does it follow from the impossibility of CP clefts mentioned earlier (see (32b) and (33b))? No, because unlike argument CPs, these clausal adjuncts can be clefted when the verb bears CT morphology.

- (36) [Mba hahazo karama be] no ianarako mafy .
 opt fut.AT.get salary big foc CT.study.1sg(gen) hard
 ‘It’s in order to earn a big salary that I’m studying hard.’

Clearly, it is not the clausal status which prevents these adjuncts from clefting when the verb is active. Thus the description of clefting must be modified; subjects and non-CP adjuncts can cleft in AT. Moreover, calling these adjuncts PPs only increases the complications. In general, PP

adjuncts can cleft. In other words, adjunct CPs do not pattern uniformly with adjunct PPs. This rather confusing array of facts is diagrammed in (37).

(37)

	CP subject	CP adjunct	PP adjunct
subject	√	*	*
AT cleft	*	*	√
CT cleft	n/a	√	√

Summing up, no adjunct CP can cleft in the active voice, but they allow clefts when the verb is CT. CPs as arguments and CPs as adjuncts have different properties. I do not have an explanation for this division among CPs. As mentioned above, I leave a in-depth study of clausal adjuncts to future research.

2.6 *Where are we?*

This section has shown the range of constructions associated with circumstantial morphology. We have seen that CT is often associated with adjuncts, although there were some counterexamples (goals and partitive themes). We have also seen that CT promotes elements of various categories. Since many CT clauses are clefts, I provided an overview of the cleft construction and some restrictions that apply.

Now that we are familiar with CT clauses, we can assess the various analyses that have been proposed to account for the data. First I will consider the connection between CT and adjuncts, so-called theta-agreement. Second I will assess the preposition-incorporation approach, which treats CT as an applicative construction. I will show that neither of these analyses can account for the full range of CT clause and therefore reject them as inadequate.

3 CT= promotion of adjuncts

As I have pointed out several times, there is an obvious link between CT and adjuncts. In many cases, CT promotes an adjunct to subject. This is in fact the traditional description of CT (Malzac (1960); Rahajarizafy (1960); Rajemisa-Raolison (1966); Rajaona (1972)). Within the generative tradition, Sityar (in press) has analyzed voice as theta-agreement. If

adjuncts do not receive a theta-role (or bear an over-arching “adjunct” role), then Sityar’s analysis also associates CT with adjuncts.¹² Let us consider this approach carefully and see how it would apply to Malagasy. I will then attempt to distinguish arguments from adjuncts. Once we have a clear distinction, I will show that CT is not limited to the promotion of adjuncts. Hence, I will reject the traditional analysis and Sityar’s formalization of it.

3.1 Theta-agreement

As mentioned in chapter 1, Sityar (in press) proposes a system of “theta agreement” to capture the correlation between voice marking and thematic roles:

- (38) The nominal features of VoiceP must agree with the thematic features of the topic.

The voice morphology on the verb is therefore a special form of subject agreement. In support of this approach, certain authors claim that theta-roles are in fact features that must be checked, similar to Case (Boskovic (1994); Hornstein (1999)). With theta-roles as features, theta-agreement is parallel to other types of agreement, for example number and person.

Let us now look at little more closely at the theta-agreement analysis of voice. In (39), I show schematically how this approach maps arguments to verbal morphology. Malagasy only has three voices, so the mapping could proceed as below.

- (39) Voice Marking I

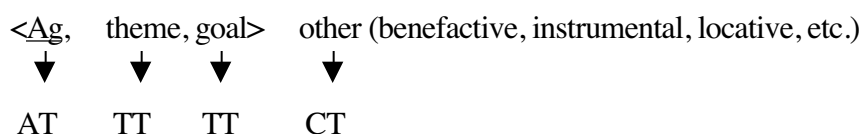

As signaled in (39), the external argument is linked to AT and all other subcategorized elements (e.g. themes and goals) are externalized with TT. Non-subcategorized elements use CT. At first glance, the theta-

¹² Note that Sityar’s analysis is for Cebuano, which splits the Malagasy CT into different voices. I am therefore modifying Sityar’s analysis to fit the Malagasy data.

agreement analysis distinguishes between arguments and adjuncts.

As an initial complication, recall from chapter 2 that there are two passives in Malagasy. In (40), I give a possible modification of (39) that takes into account the two passives.

(40) Voice Marking II

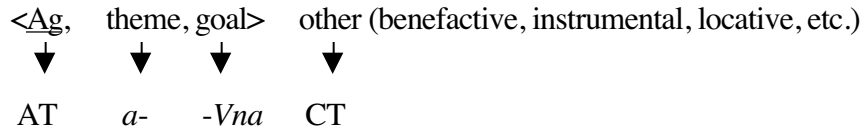

However, in the chapter on passives, we saw that there was no one-to-one mapping between the passive affix and traditional thematic roles. Some themes externalize with the *a-* passive, others with *-Vna*. Moreover, instruments appear in the subject position with the *a-* prefix. In chapter 2, I accounted for this range by proposing that “displaced themes” are promoted with the *a-* passive. Importantly, I concluded that both the *a-* passive and the *-Vna* passive promote internal (DP) arguments of the verb. Let us then return to the basic insight of (39):

(41) Voice Marking III

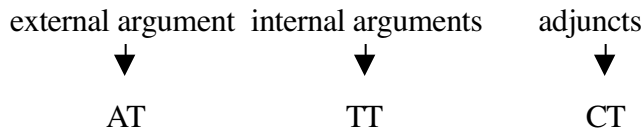

In the following sub-sections, I discuss data from PP arguments and exceptional CT (ECTM) which are problematic for the analysis in (41).

3.2 *Adjuncts vs. arguments*

What are adjuncts? Under one traditional characterization, adjuncts are non-obligatory elements in a clause. Thus in distinction to the direct object, for example, an adjunct can be omitted without affecting the grammaticality of a sentence. As mentioned in chapter 2, this test is somewhat limited. Many verbs are “optionally” transitive. Typical of this group is ‘eat’. Thus if something is an adjunct, it is optional, but not all optional elements are adjuncts. This test therefore needs to be applied with caution, but I will refer to it in the following discussion.

In chapter 2, we saw that Malagasy has another test that distinguishes adjuncts from arguments. Consider AT clefts, which were discussed in section 2.4. In general, only subjects and adjuncts can undergo A-bar movement in Malagasy. Let us see how the optionality and the clefting tests apply to the verb *manome* ‘to give’.

- (42) *manome* ‘give’
- a. Manome boky hoan’i Koto i Sahondra.
AT.give book for.gen.Koto Sahondra
‘Sahondra gives a book to Koto.’
 - b. * Manome boky i Sahondra.
AT.give book Sahondra
‘Sahondra gives a book.’
 - c. * Manome hoan’i Koto i Sahondra.
AT.give for.gen.Koto Sahondra
‘Sahondra gives to Koto.’
 - d. * [Boky] no manome hoan’i Koto i Sahondra.
book foc AT.give for.gen.Koto Sahondra
‘It’s a book Sahondra gives to Koto.’
 - e. * [Hoan’i Koto] no manome boky i Sahondra.
for.gen.Koto foc AT.give book Sahondra
‘It’s to Koto that Sahondra gives a book.’

Neither the theme nor the goal is optional, as shown by the ungrammaticality of (42b,c), and neither can AT cleft, as illustrated in (42d,e). The two tests clearly correlate and show that both the theme and the goal of *manome* ‘give’ are arguments. Hence we can classify *manome* as ditransitive.

The results for *mamaky* ‘break’ are shown in (43).

Chapter 3

(43) *mamaky* ‘break’

- a. Mamaky ny tavoahangy amin’ny langilangy i Noro.
AT.break det bottle P.gen.det stick Noro
‘Noro breaks the bottle with the stick.’
- b. Mamaky ny tavoahangy i Noro.
AT.break det bottle Noro
‘Noro breaks the bottle.’
- c. * Mamaky amin’ny langilangy i Noro.
AT.break P.gen.det stick Noro
‘Noro breaks with the stick.’
- d. * [Ny tavoahangy] no mamaky amin’ny langilangy i Noro.
det bottle foc AT.break P.gen.det stick Noro
‘It’s the bottle that Noro breaks with the stick.’
- e. [Amin’ny langilangy] no mamaky ny tavoahangy i Noro.
P.gen.det stick foc AT.break det bottle Noro
‘It’s with the stick that Noro breaks the bottle.’

Again, the optionality and the clefting tests correlate. The theme is obligatory and cannot AT cleft, as shown in (43c,d). It is therefore an argument. The instrument, on the other hand, is optional and can AT cleft (see (43b,e)). It is an adjunct. Hence *mamaky* ‘break’ is transitive. Taken together, the optionality and the AT clefting tests make a clear argument-adjunct distinction.

Now we can turn to some more difficult cases. Consider *mandroso* ‘serve’, which, like *manome* ‘give’, has both a theme and a goal. In chapter 2, I claimed that both the theme and the goal are arguments. Let us review the data.

(44) *mandroso* ‘serve’

- a. Mandroso vary hoan’ny vahiny Rasoa.
AT.serve rice for.gen.det guest Raso
‘Raso serves rice to the guests.’

- b. Mandroso vary Raṣoa.
 AT.serve rice Rasoa
 ‘Rasoa serves rice.’
- c. * Mandroso hoan’ny vahiny Raṣoa.
 AT.serve for.gen.det guest Rasoa
 ‘Rasoa serves to the guests.’
- d. * [Vary] no mandroso hoan’ny vahiny Raṣoa.
 rice foc AT.serve for.gen.det guest Rasoa
 ‘It’s rice that Rasoa serves to the guests.’
- e. * [Hoan’ny vahiny] no mandroso vary Raṣoa.
 for.gen.det guest foc AT.serve rice Rasoa
 ‘It’s to the guests that Rasoa serves rice.’

The theme of *mandroso* ‘serve’ is argument-like by both tests (44c,d). However, the optionality test and the clefting tests give different results for the goal. It is optional (44b), but it cannot AT cleft (44e). To account for this discrepancy, I suggest that there are optional arguments in Malagasy (just as in English). Thus the goal is an optional argument of *mandroso* ‘serve’. In other words, I take the clefting test as being relevant for the adjunct-argument distinction.¹³

3.3 PP arguments

Recall the theta-agreement approach to voice. Modified to fit the Malagasy system, this analysis states that internal arguments (irrespective of category) will be promoted with TT. The data from goals initially suggest that the theta-agreement approach is correct. Goals are internal arguments (as shown in (44)) and are promoted with TT, as shown in (45).

¹³ As in English and all other languages, there will in the end always be exceptions to this generalization. Recall, for example, that CP adjuncts cannot AT cleft. Yet I would hesitate to classify them as arguments. I nevertheless take the AT cleft test as distinguishing between arguments and adjuncts for the purposes of this thesis.

Chapter 3

- (45) Notoloran-dRasoa vary ny.yahiny.
pst.offer.Vna.gen.Rasoa rice det guest
'The guests were offered rice by Rasoa.'

The theta-agreement analysis also states that CT is limited to adjuncts. Interestingly, while (45) is grammatical, the goal can alternatively be promoted with CT.

- (46) Nandrosoan-dRasoa vary ny.yahiny.
pst.CT.offer.gen.Rasoa rice det guest
'The guests were offered rice by Rasoa.'

Since I have argued that goals are arguments, (46) shows that it is clearly incorrect to characterize CT in terms of the argument-adjunct distinction. CT can promote certain arguments, such as goals.

I now turn to further data which are problematic for the theta-agreement approach to CT. As above, these data involve promotion to subject of a non-adjunct with CT.

3.4 ECTM

As mentioned briefly in the first section of this chapter, CT has what appears to be an exceptional use, illustrated in (47).

- (47) Anasan-dRakoto ny.lovia.
CT.wash.gen.Rakoto det dishes
'Rakoto washes some of the dishes.'

I will discuss this case in detail in section 6. For the moment, I point out that the element promoted to subject is a theme, clearly an argument of the transitive verb *manasa* 'wash'. Nevertheless, the voice morphology is CT. As with PP arguments, the datum in (47) indicates that CT is not limited to the promotion of adjuncts.

3.5 Theory

Above, I have given some empirical arguments against the theta-agreement analysis of voice. In particular, I have shown that CT is not uniquely for the promotion of adjuncts. In certain cases, arguments (such

as goals and partitive themes) can be promoted with CT. There are also theoretical reasons to question theta-agreement. First, there is little consensus on the set of theta-roles available to the grammar and definitions of particular theta-roles are typically vague. It is not clear, moreover, that syntax is ever sensitive to the content of theta roles. For example, the theta-criterion ensures a proper mapping between DP arguments in syntax and theta positions in the predicate argument structure. But the theta-criterion is not concerned with theta role labels, *per se*. Rappaport and Levin (1988) discuss in more detail the issues that surround the role of thematic relations in syntactic theory. I conclude that thematic features are not a desirable addition to the theory.

Summing up, this section has evaluated a particular analysis of voice that links CT to adjuncts. A range of data show this to be incorrect. Moreover, theta-agreement as such suffers from theoretical shortcomings due to the direct reference to the content of theta roles. I therefore reject the theta-agreement analysis.

4 CT = preposition incorporation

As a possible alternative to the adjunct agreement analysis above, let us consider the connection that has been drawn between CT and prepositions. In his early paper on Malagasy, Keenan (1976) remarks that CT promotes elements that would be marked with oblique case (i.e. a preposition).¹⁴ In their classic work on Austronesian subjects, GHT propose that CT is a type of preposition incorporation (à la Baker (1988)). I will first outline the GHT analysis and then explore two aspects of their account: the parallel drawn with applicatives and the presence of prepositions. I show that CT is not an applicative construction and does not always involve prepositions. I therefore reject the GHT approach to CT.¹⁵

4.1 Guilfoyle, Hung and Travis

GHT state that active morphology assigns accusative Case to the theme, while passive morphology licenses genitive Case for the agent. Putting the two together creates CT, which is characterized by the availability of

¹⁴ As I discuss below, Keenan (in press) rejects his (1976) description of CT.

¹⁵ To be precise, I reject the P-incorporation part of their analysis. I agree with their observations about Case assignment in the different voices.

both accusative and genitive.

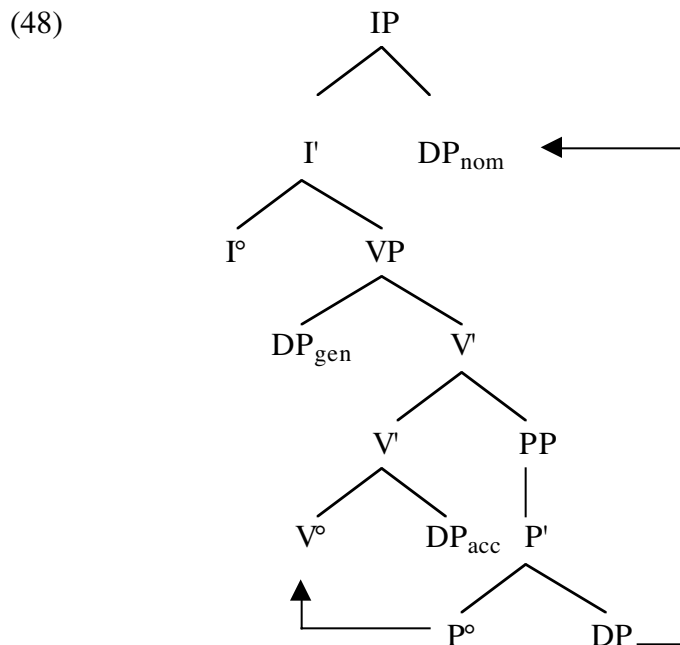

Furthermore, GHT suggest that CT involves preposition incorporation, along the lines of Baker (1988). Following preposition incorporation, the object of the preposition no longer receives Case and must raise to the matrix subject position for nominative. It is via P-incorporation that GHT integrate CT into the traditional Case analysis of voice.

4.2 Applicatives

The P-incorporation analysis of GHT equates CT and applicatives, which Baker's analysis was designed to account for. What is an applicative construction? Chung (1976a) discusses the following examples from Bahasa Indonesia, which illustrate a classic case of an applicative.

- (49) a. Orang itu masak ikan untuk perempuan itu.
 man the cook fish for woman the
 'The man cooked fish for the woman.'

- b. Orang itu me-masak-kan perempuan itu ikan.
 man the trans-cook-ben woman the fish
 ‘The man cooked the woman fish.’

In (49a), *perempuan itu* ‘the woman’ is the object of the preposition. In (49b), however, it is a direct argument of the verb. Moreover, the verb in (49b) bears special morphology. Passive can then apply, promoting *perempuan itu* ‘the woman’ to subject.

- (50) Perempuan itu di-masak-kan ikan oleh orang itu.
 woman the pass-cook-ben fish by man the
 ‘The woman was cooked fish by the man.’

(50) resembles a CT construction: a DP that was originally in a PP is in subject position.

Crucially, applicative takes an oblique and promotes it to object; hence the object position plays an important role. In fact, Baker (1988) refers to this property of applicative as “Marantz’s Generalization”: whenever a verb appears with both extra morphology and an additional DP argument bearing some oblique thematic role, that additional DP argument will behave like a surface direct object of the complex verb. Interestingly, Malagasy does not seem to have an applicative construction parallel to (49b), as shown by the ungrammaticality of (51b).

- (51) a. Nahandro ny trondro hoan’ny vehivavy ny lehilahy.
 pst.AT.cook det fish for.gen.det woman det man
 ‘The man cooked fish for the woman.’
- b. * Nahandro ny vehivavy ny trondro ny lehilahy.
 pst.AT.cook det woman det fish det man
- c. Nandrahoan’ny lehilahy ny trondro ny vehivavy.
 pst.CT.cook.gen.det man det fish det woman
 ‘The woman was cooked fish by the man.’

Instead, the object of the preposition is promoted directly to subject, as in

(51c), parallel to (50). Descriptively, it appears that the derived object position is not available in Malagasy.

Pursuing this possibility, Travis (1999); Rackowski and Travis (to appear) claim that AgrO in Malagasy is “defective” in nature and link this to the nature of movement in this language.¹⁶ Beginning with a discussion of verb-initial word order, they provide suggestive evidence that Malagasy is a predicate fronting rather than an argument fronting language. They show that this has several consequences for the realization of arguments. They suggest that argument movement in Malagasy is driven by reasons other than feature checking. AgrO can be inserted at variable points in the derivation and is invisible to further movement. As evidence in support of the unusual nature of AgrO, they point out the lack of movement to object position in applicatives, as mentioned above. They also note other processes which indicate the unavailability of the derived object position. For example, cross-linguistically possessor raising usually targets the possessor of an object. In Malagasy, possessor raising is uniquely from subject position. Moreover, apparent raising to object in Malagasy is arguably not to a derived object position (see Travis (1997)). Thus we could conclude that CT is applicative, but that some independent property of the language bars the promoted element from surfacing in a derived object position. Instead, it raises all the way to subject.¹⁷ I suggest, however, that this is not the correct conclusion.

Before we turn to CT, recall that in chapter 2 I have argued that certain elements may be base generated in a projection c-commanded by the agent and c-commanding the theme, [Spec, v2P]. I am referring to instruments and material themes. I argued that this is not a derived object position as it is limited to a subset of these elements. I then concluded that the apparent “advancement” of instruments and material themes was not a kind of applicative due to its restrictive nature. What about CT? Since it does promote a wide range of adjuncts, is it a kind of applicative that

¹⁶ For completely different reasons, Maclachlan and Nakamura (1997) argue that AgrO is “inert” in active clauses in Tagalog. Thus there indeed appears to be something unusual about the object position in these languages.

¹⁷ This property of CT falls out directly under an ergative analysis of Malagasy. I do not, however, believe Malagasy to be an ergative language. See chapter 2 for an extremely brief discussion of ergativity.

promotes directly to subject, by-passing the object position? I suggest that the resemblance between CT and applicative is spurious. In contrast to standard examples of applicative, CT is *too* broad in scope. We have seen that CT involves the promotion of almost any adjunct (time, cause, manner, etc.). As discussed in Baker (1988), applicative is restricted to a subset of obliques, the most common being benefactives, instruments and locatives. A range of facts thus leads to the conclusion that CT is not applicative.

At this point, we are confronted with the matter of redefining applicative. Early work benefited by examining the similarities between a range of constructions, under the heading “applicative”. It would now be important to look at each construction separately to determine if there is indeed a single applicative. I nevertheless believe that CT has very different properties from what has traditionally been called an applicative construction.

4.3 Prepositions

Although it may be incorrect to label CT as applicative, this does not rule out P-incorporation, *per se*. Let us therefore examine the role of prepositions in CT constructions. Keenan (in press) criticizes the GHT analysis, in particular the P-incorporation account of CT. Instead of positing prepositions in the syntax, Keenan proposes that CT encodes the prepositional meaning in the semantics. He points out that in many cases, the element that is promoted with CT never appears with an overt preposition. Keenan cites the following illustrative examples.

- (52) a. Tonga **omaly** Rabe
 arrive yesterday Rabe
 ‘Rabe arrived yesterday.’
- b. [**Omalý**] no nahatongavan-dRabe
 yesterday foc pst.CT.arrive.gen.Rabe
 ‘It was yesterday that Rabe arrived.’

- (53) a. Mivarotra **mora** ny...mpivarotra amin'io andro io
 AT.sell cheap det merchant P.gen.this day this
 'The merchants sell cheap on that day.'
- b. [**Mora**] no ivarotan'ny mpivarotra amin'io andro io
 cheap foc CT.sell.gen.det merchant P.gen.this day this
 'It is cheap that the merchants sell on that day.'

It would be possible to posit underlying null prepositions dominating these adjuncts, but such covert prepositions have little other motivation in the grammar. Moreover, Larson (1985) argues against such an approach to bare DP adverbials in English. He points out that the class of adverbials in English is broad, including PP, AdvP, CP and DP. Are all these dominated by a common invisible node?

Similar considerations apply to Malagasy, where a range of categories may serve as adverbials and are promoted to subject with CT due to their non-DP status. Several examples were discussed in section 2.2: non-referential DPs, CPs and VPs.

- (54) a. [Valopolo] no nividianany hena.
 80 foc pst.CT.buy.3(gen) meat
 'It was for 80 (ariary) that she bought meat.'
- b. [Mihinana akoho] no itsanganan-dRabe.
 AT.eat chicken foc CT.stand.gen.Rabe
 'It's while eating chicken that Rabe stands.'

Yet it is unreasonable to posit empty structure simply to capture the voice alternations.¹⁸ In sum, we cannot link CT to prepositions, because of the data in (52), (53) and (54).

There are also theoretical problems inherent to the preposition

¹⁸ Emonds (1987) and McCawley (1988) both criticize Larson's analysis and argue in favour of an empty preposition in DP adverbials. Their arguments would not extend to all the Malagasy cases, however. McCawley, for example, shows that bare DP adverbials act like PPs and not like adverbs. In Malagasy, however, all of these elements pattern together in being promoted to subject with CT, despite other distributional differences. For example, CP adverbials appear in a post-subject position, unlike most other adverbials. Nevertheless, all adverbials are promoted with CT.

incorporation approach. First, recall that in many cases, the element that is being promoted is generated in an adjunct position. Hence the preposition would be moving out of an adjunct, in violation of the Head Movement Constraint (Travis (1984)), which states that a head may only move to a head that properly governs it. Since a verb does not properly govern a PP adjunct, head movement of the preposition should be ruled out. Second, in typical cases of preposition incorporation (e.g. Bantu applicatives), Case is still available for the object of the preposition (the derived object). According to Baker (1988), for example, the verb governs the derived object after P-incorporation due to the Government Transparency Corollary (GTC). According to the GTC, a lexical category that has an item incorporated into it governs everything that the incorporated item governed in its original position. Since the verb with the incorporated preposition governs the object, it in principle can assign Case. To account for CT with preposition incorporation therefore requires the additional stipulation that Case is lost.

Summing up, a good proportion of examples of CT do involve the promotion of the object of a preposition. Nevertheless, there are many examples that do not fall under this generalization. Any account of CT that relies on the presence of a preposition is therefore inadequate. I now suggest an alternative analysis.

5 Analysis

The data in section 2 illustrated the range of elements that are promoted to subject in a CT clause. Most adjuncts can be promoted to subject, some obligatorily appearing in a cleft position due to categorial restrictions on the subject position (e.g. adverbs). What is common to all these elements? Is CT to promote adjuncts? No; we saw in section 3 that PP arguments (e.g. goals and partitive themes) can take CT. Hence CT is not purely sensitive to the argument-adjunct distinction. Does CT promote PPs? No; as shown in section 4, not all adjuncts are marked by prepositions, yet they are associated with CT morphology.

To resolve this problem, I suggest that GHT's basic insight into CT is correct. As mentioned at the beginning of this chapter, GHT propose that CT morphology satisfies the Case requirements of all the arguments of the verb. A transitive CT verb will assign accusative Case to its theme and

genitive Case to its agent. Some other element must raise into the subject position. The other element will be anything that is not structurally Case-marked by the verb.¹⁹ This will include all objects of prepositions as well as adjuncts in general, whether they take a preposition or not. We now need to understand what determines movement to the subject position.

The previous chapter presented an analysis of passive where the lack of accusative Case forced DP movement to subject position. The same cannot be true for CT. The elements that raise to subject position often do not need Case, for example adverbials. Instead, raising is forced by other considerations. Here I invoke the EPP. Malagasy has a very strong requirement that clauses have a subject.

As initial motivation for this position, note that Malagasy has no empty or dummy subjects. Keenan (1976) points out that weather expressions use an overt DP in subject position.

- (55) a. Mafana ny andro.
hot det day
'It's hot.' (lit. 'The day is hot.')
- b. Mandrivotra ny andro.
AT.wind det day
'It's windy.' (lit. 'The day winds.')
- c. Avy ny orana.
come det rain
'It's raining.' (lit. 'The rain comes.')

Similarly, there are no cases where a dummy replaces a sentential subject. Instead, the entire CP appears in subject position.²⁰

¹⁹ This analysis of CT forces the conclusion that complement CPs are Case-marked by the verb since they take passive and not CT.

²⁰ Keenan (1976) suggests that in examples parallel to (56) but with a passive verb, raising to subject optionally occurs: the embedded subject may raise into the matrix subject position. In either case, some element (CP or DP) occupies the matrix subject position. In (56) and (57), there is still the possibility that the CP is extraposed.

- (56) Mazava fa efa.....lasa.....ny mpianatra.
 clear C already gone det student
 ‘That the students have already left is clear.’

That the CP is in subject position can be shown by the placement of VP-final particles.

- (57) Tsy mazava **intsony** fa efa.....lasa.....ny mpianatra.
 neg clear NPI C already gone det student
 ‘That the students have already left is no longer clear.’

Finally, the other common construction for dummy subjects is existentials. In Paul (in press), I show that existential constructions may take an overt subject, as in (58b,c). Moreover, I argue that a null DP occupies the subject position in apparently null-subject existentials, as indicated in (58a).

- (58) a. Misy zaza mitomany pro.
 AT.have child AT.cry
 ‘There is a child crying.’
- b. Misy mitomany ny zaza.
 AT.have AT.cry det child
 ‘Some of the children are crying.’
- c. Misy molotra ny akihō.
 AT.have lip det chicken
 ‘Chickens have lips.’

Some motivation for the null subject in (58a) comes from the interpretation of existential constructions. The existential verb sets up a part-whole relation between the VP-internal material and the VP-external subject. Consider first (58c), which has a clear possessive interpretation, licensed by the inalienable possession relation. Turning now to (58b), which has a partitive reading, I suggest it means something like ‘the children have crying ones among them’. Extending this to (58a), I posit a null subject that corresponds to the universe of discourse. The reading is

'the world has crying children in it'. Malagasy thus has a strong requirement that the subject position be filled.²¹ In GB terms, this is due to the EPP.

In the context of the predicate-fronting approach to Malagasy word order discussed in chapter 1, this analysis raises interesting questions about the position of the subject and the features that trigger movement. Under a typical predicate fronting analysis, the predicate raises to [Spec, TP] and the subject surfaces in a lower [Spec, XP]. If the EPP motivates the predicate raising, as suggested by Massam and Smallwood (1996), what motivates subject raising? In most cases, the subject will be forced to raise to be assigned Case. However, as just discussed, Case considerations clearly do not drive subject raising in CT clauses since the raised element typically does not require Case (e.g. adverbs).

Massam and Smallwood (1996) propose two types of EPP to account for the difference between predicate fronting languages such as Niuean and argument fronting languages like English. In Niuean, the EPP is a strong [T] feature which attracts either a V° or a XP predicate.²² Checking obtains via head adjunction to T° or via movement to [Spec, TP], depending on the X° /XP status of the predicate. In English, on the other hand, the EPP is a strong [D] feature, which attracts a DP. The [D] feature is located on T° in clauses, but also on the head of small clauses. Following this distinction, I tentatively suggest that Malagasy has both: a strong [T] feature on T° and a strong [D] feature in X° . The former attracts the predicate and the latter attracts the subject. Unlike languages such as Niuean, Malagasy does appear to have a clearly identifiable subject position. As discussed by Massam (to appear), although subjects c-command objects in Niuean, they are not otherwise structurally distinguished (e.g. by extraction, raising, quantifier float). In Malagasy, on the other hand, the subject is associated with particular properties, for example position (recall the particle placement facts from chapter 1) and extraction. Hence there is some motivation for treating subject movement as standard argument movement. I leave this issue for further research.

²¹ Malagasy does have limited "topic-drop" of NPs in certain discourse contexts.

²² Massam (to appear) modifies this account slightly. She proposes that in Niuean the EPP is a strong [pred] feature that uniformly attracts an XP to [Spec, IP], where TP dominates IP.

Before continuing, I point out that Sells (1998) criticizes the mapping approach to voice. Although he focusses on Philippine languages, his criticisms apply to Malagasy. Sells claims that voice markers in these languages ignore any argument structure hierarchy. In other words, he argues against both theta agreement and structural analyses of voice alternations in these languages. Drawing on data from exceptional voice marking (see section 6), he shows that there is no one-to-one mapping between voice and arguments. Instead, he proposes lexical linking between a verb's arguments and voice morphemes (similar to Carrier-Duncan (1985)). In other words, arguments and voice morphemes for each verb are linked in the lexicon. I believe, however, that there are regularities to the voice system that are not captured by a lexical linking approach. Moreover, I believe that it is not by ignoring the "exceptional" uses of voice morphology that we will arrive at the correct characterization. On the contrary, these "exceptions" can provide new insight into the true nature of voice alternations. I turn to one of these exceptional instances of CT in the next section and show how it follows directly from the present analysis.

6 ECTM

If the proposed analysis of CT is correct, we would expect CT (and not TT) to promote themes that are (for some reason) not structurally Case-marked. In this section, I analyze in detail one particular use of circumstantial topic, Exceptional Circumstantial Topic Marking (ECTM). I will show that in ECTM constructions, the verb takes a QP ("quantifier phrase") theme. The DP in this QP is not Case-marked by the verb and is therefore promoted to subject with CT morphology. ECTM thus provides further evidence for dissociation between voice and theta roles and for the "elsewhere" nature of CT.

6.1 Partitives in Malagasy

For the purposes of comparison, I begin by exploring four different strategies employed in Malagasy to express partitivity: periphrastic partitives, subject position, existentials, ECTM. In the subsequent sections, I will concentrate on ECTM, due to its relevance for the analysis of CT. In order to simplify discussion, I will use the following terminology: partitives express a relation between a part or "subset" and a whole or

“superset”.

6.1.1 *Periphrastic partitives*

Malagasy has a wide range of prepositions, but the most polysemous is *amin'*. According to Rajemisa-Raolison (1966), ‘at’, ‘with’, ‘in’, ‘of’, ‘about’, ‘from’, and ‘toward’ are just a few of the relations expressed. For this reason, I gloss *amin'* as P for preposition. *amin'* is also used for periphrastic partitives, as in (59).

- (59) a. Nihinana [telo tamin'ny akondro] aho.
 pst.AT.eat three pst.P.gen.det banana 1sg(nom)
 ‘I ate three of the bananas.’
- b. Nanasa lovia [ny telo.....tamin'ny.....lehilahy].
 pst.AT.wash dish det three pst.P.gen.det man
 ‘Three of the men were washing clothes.’

Note the surface similarity between the Malagasy partitive and English: as in (59a), the subset *telo* ‘three’ precedes the preposition and the superset *ny akondro* ‘the bananas’ follows. I assume the structure of these partitives to be the following:

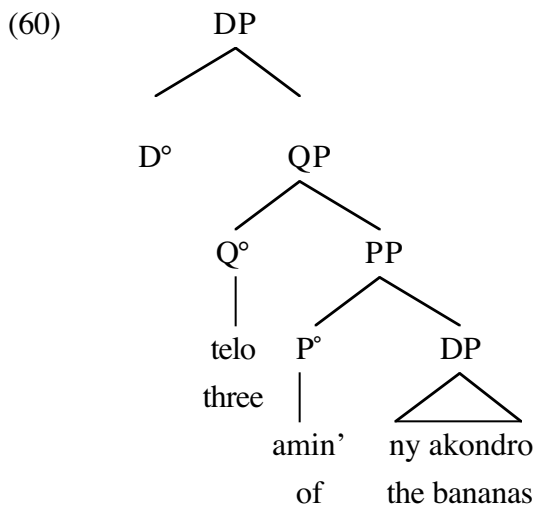

The preposition *amin'* assigns case to the DP. Due to semantic constraints on partitives, the head Q° is restricted to weak quantifiers (Jackendoff (1977); Ladusaw (1982); Hoeksema (1984)). This structure will become

important below.

6.1.2 Subject position

As pointed out by Pearson (1996c), in certain discourse contexts, the subject DP can be interpreted as partitive.

- (61) a. Nisy akondro enina teo ambonin'ny latabatra.
 pst.AT.have banana six pst.there on.gen.det table
 'There were six bananas on the table.'
- b. Nohaniko ny akondro roa.
 pst.TT.eat.gen.1sg det banana two
 'I ate two (of the) bananas.'
- c. Nihinana akondro roa aho.
 pst.AT.eat banana two 1sg(nom)
 'I ate two bananas.'

(61b) is felicitous in a context where (61a) had just been uttered. (61c), on the other hand, sounds strange. As explained by Pearson, the subject in (61b) is specific: the sentence presupposes the existence of some bananas, of which two bananas form a subset. In these contexts, therefore, partitivity appears. The subject expresses a subset; the superset is provided by the discourse.²³ (61b) is equivalent to (62), which has a periphrastic partitive.

- (62) Nihinana roa tamin'ny akondro aho.
 pst.AT.eat two pst.P.gen.det banana 1sg(nom)
 'I ate two of the bananas.'

Although interesting, this type of partitive reading will not be discussed further in this chapter.

6.1.3 Existentials

The existential construction in Malagasy has been studied most recently by Polinsky (1994); Pearson (1996); Paul (in press). These authors point

²³ Similar effects arise in Turkish with accusative Case marked objects. See Enç (1991).

out the following unusual use of the existential verb.

- (63) Misy mainty ny akondro folo.
 AT.have black det banana ten
 ‘Some of the ten bananas are black.’

Here again, partitivity arises in the subject position (compare with a “standard” existential in (61a)). This partitive contrasts with the subset partitive in (61b), however, as the subject DP in (63) sets up a superset not a subset. The subset appears to be represented by the embedded predicate, in this case, *mainty* ‘black’. In contrast to the periphrastic partitives (see (59) and (62)), no (overt) preposition is present in (63). See above references for more detailed discussion of existentials.

6.1.4 Exceptional Circumstantial Topic Marking

The final partitive strategy will be the focus of this section due to its connection to CT. A standard CT clause appears in (64) for reference in the following discussion.

- (64) Anasan-dRakoto lovia ny savony.
 CT.wash.gen.Rakoto dishes det soap
 ‘The soap is used by Rakoto to wash dishes.’

Consider now (65): the verb bears CT morphology, but the theme *ny lovia* ‘the dishes’ is in the subject position.

- (65) Anasan-dRakoto amin’ny savony ny lovia.
 CT.wash.gen.Rakoto P.gen.det soap det dish
 ‘Rakoto washes some of the dishes with the soap.’

(65) is exceptional in two respects. The theme is promoted to subject, but the verb bears CT, not TT morphology. Second, the subject is superset partitive, a reading not available in (64), and distinct from the subset subject partitive mentioned in 6.1.2. I will therefore refer to constructions like (65) as Exceptional Circumstantial Topic Marking (ECTM). Malagasy ECTM is possible with a wide range of transitive verbs (e.g. activities: *maka*

'take', *mandoko* 'paint', *mifoka* 'smoke', *mamono* 'kill'; states: *mitia* 'like', *mahafantatra* 'know').²⁴ In keeping with the above descriptions, I point out that the subject DP expresses a superset. The subset is not expressed as an overt DP. In this way, the ECTM construction resembles the existential: compare (63) with (65). In both cases, the subject is the superset. Importantly, the partitive reading in (65) arises without any overt marking, such as a preposition.

Summing up, there are four strategies for expressing partitivity in Malagasy. For the remainder of this section, I concentrate on ECTM, arguing in favour of a QP theme.²⁵

6.2 ECTM: An analysis

The ECTM construction has not received any analysis within the generative literature as far as I am aware. The exact status of this construction is the subject of some disagreement within the traditional Malagasy grammars. For example, according to Rahajarizafy (1960), Malzac (1960) and Rajaona (1972), examples such as (65) illustrate one of the normal uses of circumstantial voice. For these grammarians, 'part of' is therefore comparable to the various oblique relations of circumstantials. Rajemisa-Raolison (1966), however, lists the partitive use of CT as an exception. In the following section, I will examine ECTM in more detail and evaluate the traditional claims. In fact, as will be discussed below, I conclude that both are correct: ECTM is a normal CT construction, with a special twist.

Recall my analysis of CT: promotion to subject of anything but a structurally Case-marked DP. I therefore posit that in an ECTM construction, the theme is generated as a QP. The tree in (66) shows the structure underlying (65), omitting the instrumental PP (*amin'ny savony* 'with the soap') for simplicity.²⁶

²⁴ There is some speaker variation in the precise range of verbs that allow ECTM.

²⁵ In fact, the partitive reading can arise in other positions (e.g. goal). These examples are therefore ambiguous since CT normally promotes goals (see section 3.3).

(i) Nandrosoan-dRakoto vary *ny vahiny*.
 pst.CT.serve.gen.Rakoto rice det guest
 'The guests were served rice by Rakoto.'
 or 'Some of the guests were served rice by Rakoto.'

For the purposes of this discussion, I concentrate on themes, as they constitute the most surprising instance of CT.

²⁶ In the tree in (66), the QP theme is projected in [Spec, VP]. Nothing in this analysis hinges on this particular position, as opposed to the sister to V, for example. I also assume the partitive

(66)

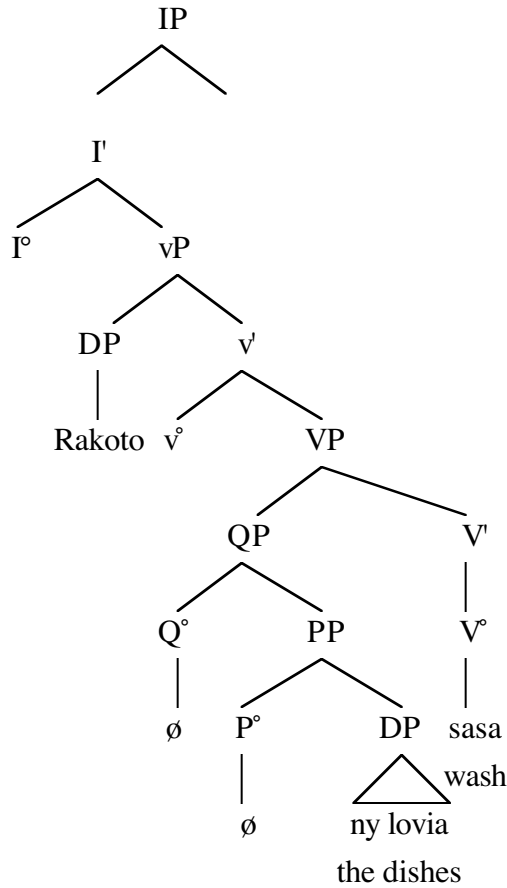

In (66) the verb takes a QP complement. The head of this QP is an abstract quantifier corresponding to ‘some’ (crucially, a weak quantifier). In certain contexts, the preposition in the PP complement to Q° can be overtly realized, as we will see below. The DP complement to the P° raises to [Spec, IP] for nominative Case. The final structure is given in (67).

theme to be a bare QP rather than a full partitive DP (cf. (60)). Extraction out of DPs is not in general possible.

- (i) * [Momban'ny alika]_i no namakian-dRasoa (ny) boky_i t_i.
 about.gen.det dog foc pst.CT.read.gen.Rasoa (det) book
 ‘It’s about dogs that Rasoa read a book.’

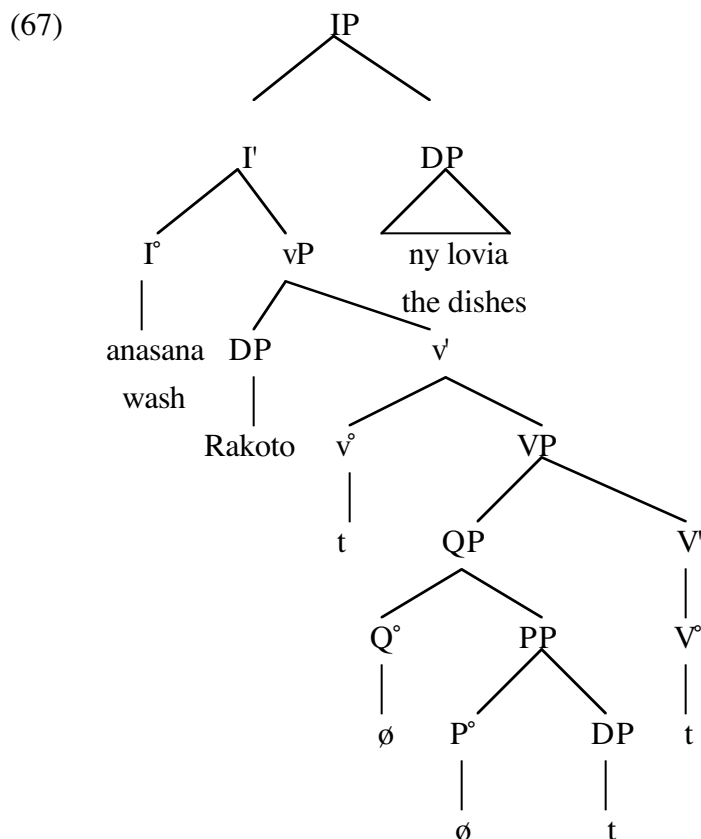

I now turn to some facts that provide evidence in support of the above analysis. The crucial characteristic of my analysis of ECTM is the presence of a QP theme (i.e. both category and position are important).²⁷

6.3 Data

In the following subsections, I argue for the presence of an underlying quantifier in the ECTM construction. Further, I show that the partitive subject originates in a theme position

6.3.1 Prepositions and partitivity

The proposed structure has a QP theme, where the head of this QP expresses partitivity or ‘some of’. Malagasy does not have an overt quantifier that corresponds to this meaning; I nevertheless assume a null weak quantifier to be present in these structures in order to account for the interpretation. Recall that the preposition *amin’* is required to assign

²⁷ The above analysis bears some superficial similarity to Kayne’s account of *de* NP in French (Kayne (1975)). He posits an underlying null head [\emptyset *de carottes*] that corresponds to a quantifier. Importantly for Kayne, however, this is not a partitive NP as partitives and *de* NPs do not share the same distribution.

Case to the DP, along the lines of regular partitives discussed in section 6.1.1. This is illustrated in (68a) below. We have already seen that when a PP is promoted to subject with CT, the preposition may be overt in the cleft position (an illustrative example is given in (68c)). This is also true in ECTM, as illustrated in (68b). As with most CT clefts, the preposition is optional in both (68b,c).

- (68) a. Manasa [\emptyset amin'ny lovia] Rakoto.
 AT.wash P.gen.det dish Rakoto
 'Rakoto washes some of the dishes'
- b. [(Amin')ny lovia] no anasan-dRakoto.
 (P.gen.)det dish foc CT.wash.gen.Rakoto
 'Rakoto washes some of the dishes'
- c. [(Amin')ny savony] no anasan-dRakoto lovia.
 (P.gen.)det soap foc CT.wash.gen.Rakoto dish
 'It is with soap that Rakoto washes clothes.'

(68b) shows that the partitive DP in ECTM originates as the complement of a preposition. I link the presence of this preposition to the use of prepositions in periphrastic partitives, discussed earlier.

6.3.2 *Theme or not a theme?*

I now examine the theme status of the partitive subject in ECTM. First note that the verbs that are compatible with ECTM are not "optional" transitives. In other word, the theme argument must be overtly expressed.

- (69) * Manasa Rakoto.
 AT.wash Rakoto
 'Rakoto washes.'

If the argument structure of the verb is to be satisfied, there must be some element in the theme position.

As a second test for theme-hood, I turn to secondary predication. The

data in (70) illustrate that depictive secondary predicates are possible in AT, TT, CT and in ECTM.

- (70) a. Misotro mangatsiaka ny kafe Raṣoa.
 AT.drink cold det coffee Rasoā
 ‘Rasoā drinks coffee cold.’
- b. Sotroiny mangatsiaka ny kafe.
 TT.drink.3(gen) cold det coffee
 ‘She drinks coffee cold.’
- c. [Ao an-dakozia] no isotroany mangatsiaka ny kafe.
 there acc-kitchen foc CT.drink.3(gen) cold det coffee
 ‘It’s in the kitchen that she drinks coffee cold.’
 ≠ ‘It’s in the kitchen cold that she drinks coffee.’
- d. Isotroany mangatsiaka ny kafe.
 CT.drink.3(gen) cold det coffee
 ‘She drinks some of the coffee cold.’

Note that in the examples in (70), the secondary predicate, *mangatsiaka* ‘cold’, is always predicated of the theme of the verb. This restriction can be accounted for by Williams (1980)’s mutual c-command condition on predication, if we assume the secondary predicate to be adjoined to *V'* at the (lower) VP-level (Baker (1997)).

(71)

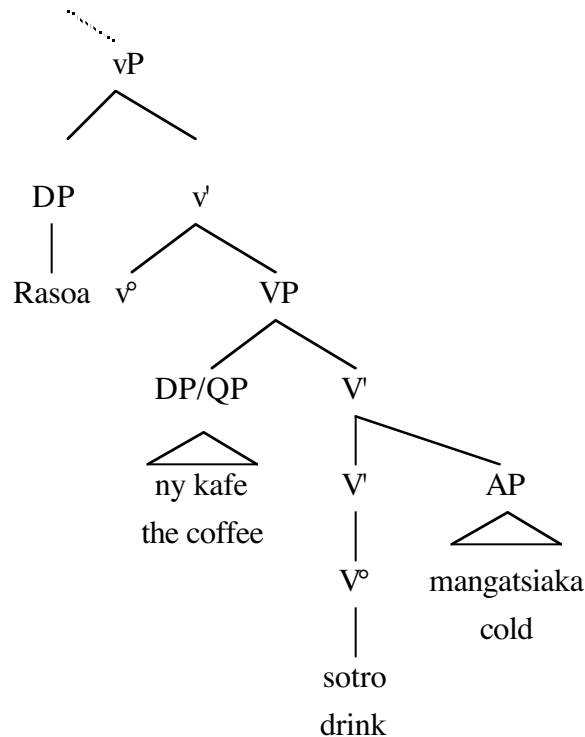

The grammaticality of (70d) therefore suggests that the partitive subject in an ECTM construction has theme status. What is crucial is not the particular analysis of secondary predication. Instead, it is important that partitive subjects in ECTM constructions pattern with themes, as in (70a,b), and not with adjuncts (cf. (70c)).

As further support for generating the partitive subject as a theme, consider the following examples. (72) reveals that the theme role of the verb is saturated by the partitive DP and cannot be overtly expressed with an independent DP. In other words, both the superset and the subset of a partitive cannot cooccur in ECTM.

- (72) a. * Nihinanako (ny) mainty ny akondro.
 pst.CT.eat.1sg(gen) det black det banana
 ‘Of the bananas, I ate some black ones.’
- b. * Nihininako akondro ny voankazo.
 pst.CT.eat.1sg(gen) banana det fruit
 ‘Of the fruit, I ate some bananas.’

The data in (72) indicate that the partitive DP blocks the presence of a theme. The proposed structure in (66) accounts for these cooccurrence restrictions by generating a QP in theme position. Clearly, another theme cannot be projected.

6.4 Floating quantifiers: a problem?

In (72), we saw that in ECTM constructions, the theme position cannot be occupied by an independent nominal. Interestingly, there are cases where the theme position can apparently be filled by a numeral.²⁸ I suggest that this numeral is the overt realization of the head of QP. This is illustrated in (73a), an ECTM construction (cf. *ny lovia telo* ‘the three dishes’). Such “floating quantifiers” are ungrammatical in all other voices: TT (73b); AT (73c); and CT (73d).

- (73) a. Anasan-dRakoto telo ny lovia.
 CT.wash.gen.Rakoto three det dishes
 ‘Rakoto washes three of the dishes.’
- b. * Sasan-dRakoto telo ny lovia.
 TT.wash.gen.Rakoto three det dishes
 ‘Three dishes are washed by Rakoto.’
- c. * Manasa telo lovia ny ankizy.
 AT.wash three dishes det children
 ‘The three children wash dishes.’
- d. * Nihirako telo ny ankizy.
 pst.CT.sing.1sg(gen) three det children
 ‘I sang for the three children.’

There arise two questions about the above data. First, why are floating

²⁸ As well as numerals, the weak quantifiers *betsaka* ‘many’ and *vitsy* ‘few’ may appear in this “floated” position in ECTM constructions.

(i) Anasan-dRakoto *betsaka* ny lovia.
 CT.wash.gen.Rakoto many det dish
 ‘Rakoto washes many of the dishes.’

quantifiers only available in ECTM constructions?²⁹ Second, what is the position of the floating quantifier?

To better understand the data, compare the examples in (74).

- (74) a. Anasan-dRakoto telo ny lovia.
 CT.wash.gen.Rakoto three det dish
 ‘Rakoto washes three of the dishes.’
- b. Anasan-dRakoto ny lovia telo.
 CT.wash.gen.Rakoto det dish three
 ‘Rakoto washes some of the three dishes’

Whether the numeral appears within the DP or “floated” affects the meaning of the sentence. (74a) is not equivalent to (74b). In the former, the floating quantifier specifies the cardinality of the set of washed dishes (=‘three of the dishes’). In the latter, the numeral specifies the cardinality of the set of dishes under consideration (but not the washed ones).

To solve this puzzle, I propose that the weak quantifier in (74a) is an overt realization of the head of QP. The DP has raised to the subject position, stranding the Q *telo* ‘three’.

²⁹ There are also strong “floating quantifiers” in Malagasy, which quantify strictly over the subject position. Two examples are given below.

- (i) a. Nohanin’ny mpianatra **daholo** ny voankazo.
 pst.TT.eat.gen.det student all det fruit
 ‘The students ate all the fruit.’
- b. Nihinana voankazo **daholo** ny mpianatra.
 pst.AT.eat fruit all det student
 ‘All the students ate the fruit.’

Since these quantifiers are subject-sensitive, I tentatively suggest that they are subject-oriented adverbs rather than truly “floated” quantifiers (Doetjes (1997)).

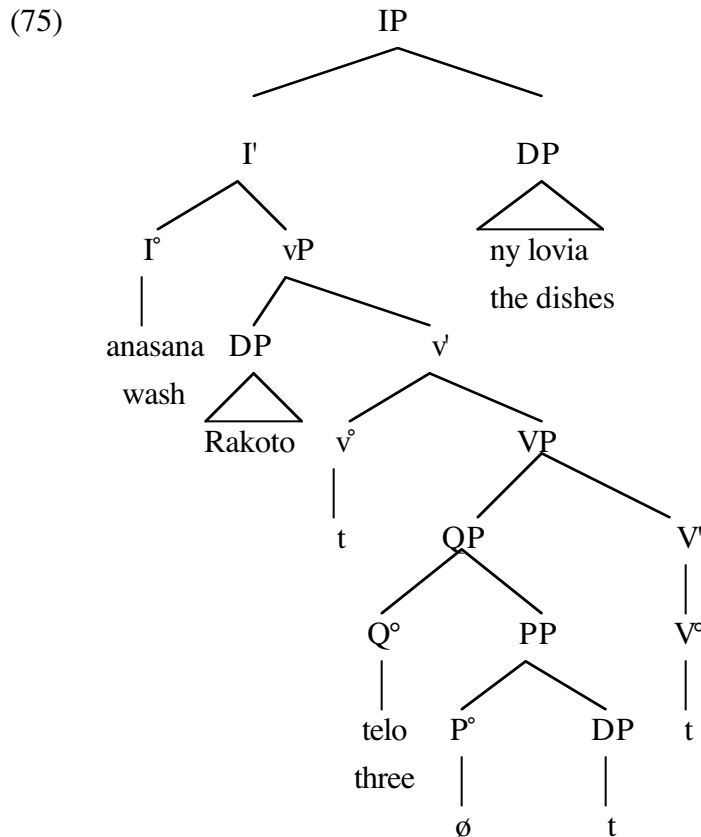

The structure in (75) ensures the correct reading for the quantifier. Recall from above that this is the structure of a partitive DP. Hence, the interpretation will be ‘three of the dishes’.

In (74b), on the other hand, the numeral originates within the DP embedded under QP. Like other nominal modifiers, the numeral appears after the N° , perhaps in the head of NumP. The entire embedded DP raises to subject position and the null Q° is interpreted as ‘some’.

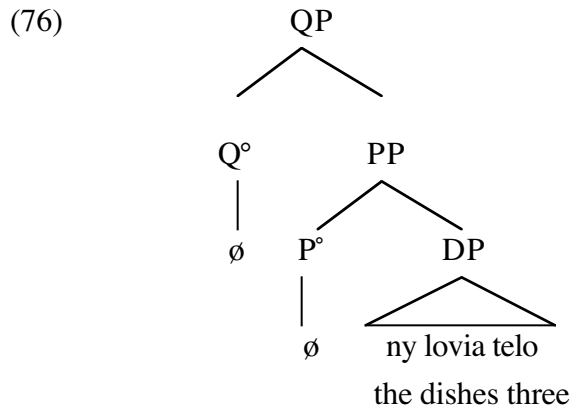

From the structures in (75) and (76), we can see that there are two positions for numerals in Malagasy: prenominal and postnominal. The following example illustrates that it is possible for both these positions to be filled.

- (77) Anasan-dRakoto telo ny lovia folo.
 CT.wash.gen.Rakoto three det dish ten
 ‘Rakoto washes three of the ten dishes.’

In (77), *telo* ‘three’ is the Q° and *folo* ‘ten’ is Num°.

This structure also correctly rules out “quantifier float” from other DPs. The numeral will only be stranded when a DP embedded in a QP moves to the subject position. In the case of regular themes, for example, an entire partitive DP (which includes the QP) moves to subject position and no stranding will be possible. Finally, note that the only element that can appear in the “object” position of an ECTM construction is a numeral. DPs or N°s such as in (72) above will not be generated in the head of QP. Thus the floating quantifier data do not create a problem for the proposed analysis. In fact, they are evidence in favour of the underlying QP in ECTM.

6.5 Malagasy madness?

The data from ECTM illustrate a clear mismatch between thematic features and voice. Drawing on similar data from Tagalog and Inibaloi, both Ballard (1974) and Foley (1976) argue against a theta-agreement approach to voice. Thus, a range of Austronesian languages require a

structural approach to voice. The Tagalog and Inibaloi data are discussed directly below, but I will not offer an explicit analysis of these languages. Although the data are similar to Malagasy ECTM, I believe that the underlying structures are different. Nevertheless, the conclusion to be drawn from these data is the same: voice morphology does not map directly to particular theta-roles, contra the theta-agreement analysis. We will see below that these languages use voice to signal shifts in interpretation. The exact meaning change is different in each language, but this is not surprising given the different range of CT-like voices in Philippine languages. Interestingly, similar shifts can be observed with partitive Case marking in Finno-Ugric, to be discussed in section 6.5.3.

6.5.1 Tagalog

Unlike Malagasy, Tagalog makes fine-grained distinctions among adjuncts in verbal morphology: e.g. Benefactive, Locative, Instrumental. Of these, the Locative is used for the equivalent of the ECTM construction, as shown in (78b). (78a) is the Theme Topic (TT) counterpart. (Data from Foley (1976).)

- (78) a. Binasa ng lalake ang libro.
 TT.read gen man nom book
 ‘The man read the book.’
- b. Binasahan ng lalake ang libro.
 LT.read gen man nom book
 ‘The man read from the book.’

The partitive subject in (78b) is understood as the argument of a P° , as encoded by the verbal morphology. Moreover, the Tagalog data suggest that this preposition is locative in nature. As in Malagasy, the normal “passive” (TT) is possible with definites only. If the theme DP is partially affected by the action of the verb, an “adjunct” voice is used, in this case locative voice. The Tagalog data thus closely resemble the Malagasy.

6.5.2 Inibaloi

Ballard (1974) discusses the different verbal affixes that appear in Inibaloi, another Philippine language. He notes that a single verb may appear with different affixes but with no apparent grammatical change in the clause.

- (79) a. Bedatbaten to'y pingkan.
 line-up 3sg plates
 'She will line up the plates.'
- b. Ibalatbat to'y pingkan.
 line-up 3sg plates
 'She will line up the plates.'

In both cases, the theme of the verb, *pingkan* 'plates', appears in the subject position. But the verbal affixes differ. (79a) uses the usual object focus (patient oriented) marker *-en*, while the *i-* prefix in (79b) is a locative marker. Ballard notes a semantic shift between the two examples. (79a) describes the result obtained: all the plates were affected. In (79b), however, it is the position of the plates that is being affected. In the former, therefore, we have a typical passive construction, with no special semantic effects. In the latter, the difference in meaning is not clear from Ballard's description. However, if we think of (79b) as expressing the equivalent of 'She will do lining-up of the plates', the partitive (or indefinite) reading emerges. In other words, the focus is on the process described by the verb rather than the fact that all the plates were lined up.

Although the Inibaloi data do not align perfectly with the Malagasy and Tagalog ECTM discussed above, I believe there is an important similarity between the use of voice in these languages. All three have regular "passive" to promote a theme to subject. All have other voice alternations available, usually reserved for oblique elements. And these languages can use these oblique voices for themes with similar (but not identical) semantic effects. Importantly, the difference in voice morphology is not matched by a difference in thematic role, per se. Hence, we have further evidence that theta-agreement cannot account for the full range of voice data in Austronesian. Further, the data suggest that voice, in particular CT-like voice, may require distinct analysis in different languages. I address this question briefly in section 7.

6.5.3 Partitive Case

Interestingly, partitive Case in Finnish and Mordvinian (both Finno-Ugric

languages) shows a pattern similar to the exceptional Austronesian voice, but in a slightly different way (Kiparsky (1995)). In Finnish, partitive Case has both a DP-related function and an aspectual function. Partitive marks quantitatively indeterminate DPs (independent of aspect) and objects of atelic predicates. (80a) is an example of a telic predicate with a bare plural object, marked with partitive Case. (80b) illustrates that the object of an atelic predicate is marked with partitive, irrespective of the quantificational properties of the object.

- (80) a. Saa-n karhu-j-a.
 get-1sg bear-pl-part
 ‘I’ll get bears.’
- b. Etsi-n karhu-j-a.
 seek-1sg bear-pl-part
 ‘I’m looking for (the) bears.’

The Mordvinian partitive Case ending is cognate with the Finnish, but is purely DP-related. It occurs on indefinite bare plurals or mass noun objects, as shown in (81). (Data from Kiparsky (1995).)

- (81) Mon, ada, sim-t-tan vina-do.
 ok fine drink-cause-1sgsubj/2sgobj vodka-part
 ‘Ok, so I’ll let you drink vodka.’

In other words, Mordvinian partitive Case is restricted to partitive objects. It does not mark the objects of atelic verbs. Although partitive Case has both aspectual (VP) and DP functions in Finnish, it only has the DP function in Mordvinian. In Malagasy, the exceptional voice (CT) is used to mark partitivity, a DP function. In Inibaloi, the exceptional voice is used to mark a shift in aspect, a VP function.

6.6 Conclusion

This section has been a “case study” in how the proposed analysis of CT accounts for a very particular use of this voice, ECTM. I have shown that the unusual partitive reading in CT constructions arises due to an

underlying QP in theme position. The quantifier encodes partitivity. The DP complement to this Q° is promoted to subject via CT because it is not structurally Case-marked by the verb. Interestingly, other languages use voice to mark similar effects.

7 Circumstantial Topic: Other languages

In the discussion of passive in chapter 2, it was suggested that the different passive types are sensitive to the different structural positions of internal arguments. The *a*-passive targets arguments in [Spec, v2P] while the *-Vna* passive promotes DP arguments in VP. Thus voice in Malagasy appears to make fine-grained distinctions between syntactic positions. Once we look at circumstantial topic, however, these distinctions disappear. Recall that circumstantial topic is used to promote anything but structurally Case-marked DPs to subject. This heterogeneous class includes adjuncts and objects of prepositions. Clearly, these elements are generated in a range of structural positions. Among adjuncts, it is often assumed that there are different levels of adjunction - VP, IP, etc. Moreover, as shown in section 2.2, adjuncts are of differing categorial status: adverbs (heads), PPs, CPs, VPs. Yet all adjuncts use the one CT. Similarly, I have provided arguments that ECTM involves a partitive theme. The base position of the subject in an ECTM construction is thus in the canonical direct object position, not an adjunct. In sum, CT is much more of an all-encompassing voice alternation.

In contrast, some Austronesian languages make finer-grained distinctions among adjuncts. For example, Tagalog has locative, benefactive and instrumental voices.³⁰ The data below are from Foley (1976).

- (82) a. Tinirhan ng lalake ang bukid.
 LT.buy gen man nom farm
 ‘The man lived on the farm.’

³⁰ The locative voice is used for locations, sources and goals (and partitives). Foley notes that instrumental focus clauses are grammatical but rare. According to Kroeger (1990), the instrumental voice in Kimaragang Dusun is mainly used in extraction contexts (relative clauses, clefts, *wh* questions). This is probably due to pragmatic constraints against having an instrument as the subject.

- b. Ibinili ng lalake ng isda ang bata.
 BT.buy gen man acc fish nom child
 ‘The man bought some fish for the child.’
- c. Ipinutol ng lalake ng isda ang kutsilyo.
 IT.cut gen man acc fish nom knife
 ‘The man cut the fish with the knife.’

In Tagalog and other Philippine languages, voice morphology not only indicates the presence of a preposition, but also encodes the nature of that preposition. In these languages, the voice morphology and the underlying preposition are directly linked, unlike what we have seen for Malagasy. It therefore appears that the preposition-incorporation analysis is appropriate for Philippine languages. For these reasons, I suggest that the Philippine prepositional voices are a form of applicative. The range of “adjuncts” that can be promoted to subject is limited, much in the same way as Bantu applicatives, as mentioned in section 4.³¹

The discussion of Malagasy voice (TT in chapter 2 and CT in the present chapter) has indicated that in order to understand voice alternations in a particular language, an in-depth study is necessary. For example, it was only by considering the full range of passive constructions that an analysis of CT was possible. Therefore, my conclusions about Tagalog are tentative in nature. The Tagalog equivalents of CT given in (82) may in fact require an event structure analysis, as proposed by Naumann and Latrouite (1999). I leave for future research a comparison of voice systems within western Austronesian. The present thesis indicates the direction that such a comparative study would take.

8 Conclusion

In this chapter, I have examined the circumstantial topic construction in Malagasy. From the perspective of English, this voice is highly unusual: in many cases, an adjunct is promoted to subject. I explored a range of data which illustrated the heterogeneous quality of CT. One of the

³¹ One common criticism of the P-incorporation analysis of Bantu applicative is that despite different prepositions, the applicative morphology is constant. Tagalog presents the reverse situation. A single preposition, *sa*, is used to mark elements which will be promoted to subject with distinct voices.

principal challenges of any analysis of CT lies in accounting for this wide range. I pointed out two main approaches to CT that have been proposed in the literature. The first links CT to adjuncts; the second exploits the connection between CT and prepositions. Despite the attractiveness of these analyses, I showed that neither accounts for the full array of CT clauses. Under my analysis, CT is an “elsewhere” voice. In a CT clause, all the arguments of the verb receive Case. Since Malagasy has a strong requirement that the subject position be filled, any element other than a structurally Case-marked DP is promoted to subject. One advantage of this analysis is that it easily accounts for what appears to be an exceptional use of CT, the ECTM construction.

We are now in a position to compare CT with TT, which was discussed in chapter 2. In chapter 2, I showed that two passive affixes, *a-* and *-Vna*, promote distinct arguments. I argued that *a-* promotes DPs from [Spec, v2P], while *-Vna* promotes DPs from the lower VP. The former is therefore sensitive to position and the latter to domain. The discussion of CT has shown that this voice is again different from TT. CT does not target a particular position nor is it restricted to a particular domain. Since adjuncts are projected at various levels in the phrase structure, CT can promote an element from almost any structural position.

In both the present chapter and chapter 2, I have argued that voice can serve as a probe into phrase structure. In particular, I looked at the position of internal arguments and the argument-adjunct distinction. All of these elements are situated within the extended verbal projection. In the next chapter, I turn my attention to complementizer layer of the clause. Since I often use the cleft construction as a test for structure, in chapter 4 I will provide an explicit analysis of the syntax of clefts. I will also contrast clefts with topicalization constructions. In the same way that the voice system “feeds” A-bar movement, chapters 2 and 3 set up the necessary background to the discussion of topic and focus in chapter 4.

Chapter 4: The left periphery

1 Introduction

The previous chapters have investigated the projection of arguments and adjuncts in the VP and IP layers. I have primarily focussed on the base position of these elements and the implications for voice alternations. I now turn my attention to cases where arguments and adjuncts appear in the left periphery. We have already touched on the cleft strategy, here I will provide an analysis. I will consider the Malagasy data in light of the “split CP” hypothesis of Rizzi (1997). I will begin with an overview of Rizzi’s proposal and how it applies to Malagasy topic and focus. I will be concerned with the relative position of these elements and conclude that like Italian, Malagasy has topic>focus>topic ordering.

In Malagasy, the cleft construction is associated with a particular focus interpretation. Since the cleft has been important in previous chapters (especially for the discussion of circumstantial topic in chapter 3), the core of the present chapter is devoted to the cleft construction. First, I show that the cleft in Malagasy is an equative construction: the clefted element is a predicate and a headless relative is the subject. Next, I argue that the clefted element, which carries a special focus interpretation, appears in the specifier of a functional projection, FocusP. I then address apparent multiple clefts and show that these involve two separate projections: FocusP and TopicP, as proposed in the first part of the chapter. I argue against other possible analyses of multiple clefts, namely coordination, amalgamation and multiple specifiers. Finally, I look at some interesting properties of multiple *wh*-movement.

2 The left periphery

Drawing mainly on data from Italian, French and English, Rizzi (1997) argues for the following projections in the “complementizer layer” of the clause. (All the “Comp” projections are in bold.)

(1)

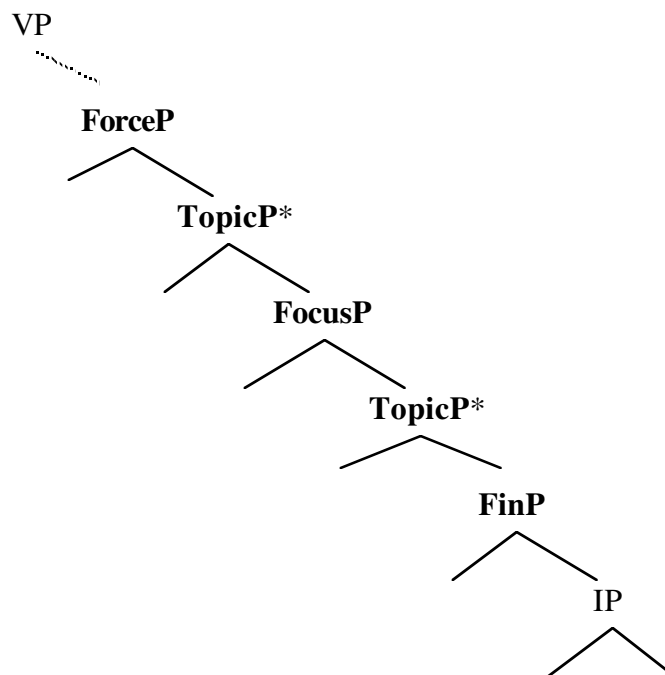

Roughly speaking, the complementizer system connects a proposition (the lower IP) and a higher clause (or discourse, in the case of root clauses). The matrix verb selects a clause of a particular type or “force” (e.g. declarative, interrogative). At the other end of the CP layer, the complementizer selects an IP of a certain tense specification or “finiteness”. For Rizzi, the force and finiteness distinctions are encoded on heads of separate projections, ForceP and FiniteP, respectively. In between, we have topic and focus positions. I will be concerned with the topic and focus projections in Malagasy and will not address the issue of the different Comp-like heads. Rizzi’s “splitting” of Comp into different projections parallels work on Infl by Pollock (1989) and the VP-shell of Larson (1988). This body of work attempts to represent finer semantic, syntactic and morphological distinctions in phrase structure.

As shown in the above tree, Rizzi argues for two topic positions, which sandwich the focus projection. The following Italian example illustrates this ordering.

- (2) [topic A Gianni], [focus QUESTO], [topic domani], gli dovrete dire.
to Gianni this tomorrow him should tell
‘To Gianni, THIS, tomorrow, you should tell him.’

Moreover, Rizzi claims that topics may iterate (marked by a * on each TopicP), although focus is limited to a single position.¹ The Malagasy data will support Rizzi's proposal, for Malagasy also has topic>focus>topic word order in the left periphery. In the remainder of this section, I discuss topic and focus, concentrating on positional facts. In sections 3-5, I will look in more detail at the structure of the focus construction. I leave a proper study of topicalization for further research.

2.1 Topic and focus

This is not the place to review the large body of literature on topic and focus. Instead, I will outline some basic characteristics of these notions; see Rooth (1996) for an overview of focus and Erteschik-Shir (1997) for an account of both topic and focus in terms of "focus structure". Following Jackendoff (1972), I assume that focus can be defined in terms of the discourse notion of presupposition. Presuppositions are what both the speaker and hearer assume to be the case at the point when the sentence is uttered. Focus corresponds to the non-presupposed part of the sentence. In other words, focussed elements are in some sense "new" information. A simple sentence is ambiguous; depending on the context, it can have different presuppositions. I take the following example from Zubizarreta (1998) to illustrate this point. In each of (3a,b,c,d) we have the same sentence that is assigned different focus interpretations. The focussed constituent is marked with [F]. A constituent not marked [F] is interpreted as the presupposition or as part of the presupposition. Each example is associated with an (implicit) context question.

- (3) a. [F John [ate [the pie]]].
[What happened?]
b. [John [F ate [the pie]]].
[What did John do?]
c. [John [ate [F the pie]]].
[What did John eat?]

¹ The limit on focus derives from semantic restrictions. See Rizzi (1997) and Zubizarreta (1998) for some discussion. This restriction will be important when we turn to apparent multiple foci in section 5.

- d. [[_FJohn] [ate [the pie]]]].
[Who ate the pie?]

The examples in (3) do not exhaust all the different possible focus readings, but illustrate a few.

Topics, on the other hand, are what a statement is about. They are old information that is contextually salient. The topic is set off from the rest of the clause: the comment. The comment is predicated of the topic and introduces new information. Using the terminology of Erteschik-Shir (1997) (who adopts Reinhart (1981)'s file metaphor), a topic signals the listener to locate an existing card and add the new information from the comment to that card.

Before continuing, I note that in this chapter I will solely be concerned with topic and focus as associated with displaced elements. In other words, I will ignore the focus interpretation that arises with prosodic prominence. I will also not investigate the topic-like properties of the clause-final subject position (see Pearson (1996a)). Instead, I concentrate on the clause-initial positions reserved for topicalized and focussed elements. In this way, Malagasy resembles English, Italian, Hungarian and many other languages. In the next sections, I look at the hierarchical relations among these positions.

2.2 *Topic > focus*

As discussed by Keenan (1976), Malagasy has a topic position, which is followed by *dia*, and a focus position, which is followed by *no*, at the left edge of the clause. In the following examples, we see that topics precede focussed elements and that the inverse order is ungrammatical. In (4a), the topicalized element is the object of the verb and hence is “doubled” by the resumptive pronoun *azy* (see below for discussion of the resumptive pronoun strategy).^{2,3}

² I translate Malagasy topicalization with English left dislocation and with “as for”, depending on which seems the most natural in context. I make no claims about the relation between Malagasy and English topicalization, however.

³ Due to the complex structure of topic and focus constructions, in this chapter, I will not underline the subject. Instead, where necessary, I will use square brackets to indicate relevant constituents.

- (4) a. [Ity radara ity]_{topic} dia [ny Rosiana]_{focus} no nanao azy.
 this radar this top det Russian foc pst.AT.do 3(acc)
 ‘As for this radar, it’s the Russians who made it.’
- b. * [Ny Rosiana]_{focus} no [ity radara ity]_{topic} dia nanao azy.
 det Russian foc this radar this top pst.AT.do 3(acc)
 ‘It’s the Russians who, this radar, made it.’

I will refer to the topic *ity radara ity* ‘this radar’ in (4a) as a “*dia topic*”.

Drawing on similar data from Maori, Pearce (1999) argues for a single topic position that c-commands focus.⁴ I will show, however, that Malagasy has a second topic projection below focus. An illustrative example is given below.

- (5) [Ny lovia maloto]_{topic} dia [isan’andro]_{focus} [Rabe]_{topic} no manasa azy ireo.
 det dish dirty top each’day Rabe foc AT.wash 3(acc) pl
 ‘As for the dirty dishes, it’s every day that Rabe washes them.’

In (5), *Rabe* is in the lower topic position. Before arguing for this additional TopicP, I will give some background on topic and focus in Malagasy.

2.3 *dia topics*

I will not provide an in-depth discussion of *dia topics*. Instead, I give an overview of some particularities of topicalization as relevant for the discussion of focus. The main conclusion is that *dia topics* occupy a position structurally superior to focussed elements. I also show that topicalization can be derived either via movement or via base generation. For the former, only subjects and adjuncts may be topicalized, as is usual for extraction in Malagasy. The latter strategy allows a wider range of elements to appear in the topic position.

In passing, note that what I am calling “*dia topicalization*”, Keenan (1976) refers to as “weak topicalization”. He claims that these are not true

⁴ Tagalog also has topic>focus order (Kroeger (1993)), as do Spanish (Zubizarreta (1998)) and the Mayan languages discussed in Aissen (1992). None of these languages allows a topic below focus. Rizzi (1997: fn 17) points out that some Italian speakers find the lower topic marginal. I return to this issue in section 5.5.

topics of conversation, as evinced by their common use with place and time adverbials. Strong topicalization, where *raha* ‘if’ precedes the topic, defines a topic of importance for the conversation. The contrast in (6) illustrates that in certain cases of strong topicalization, such as (6a), there is no “gap” corresponding to the topic; this is not possible with the weak topicalization (*dia* topic) in (6b).

- (6) a. strong topicalization
 Raha ny voankazo dia tiako ny akondro.
 if det fruit top like.1sg(gen) det banana
 ‘As for fruit, I like bananas.’
- b. weak topicalization
 * Ny voankazo dia tiako ny akondro.
 det fruit top like.1sg(gen) det banana
 ‘Fruit, I like bananas.’

I do not discuss strong topicalization any further.⁵

Topicalization involves a fronted element which is followed by the topic particle *dia*.⁶ Interestingly, the topic has different properties depending on whether there is a focussed constituent in the clause or not. Looking first at simple topic structures, the range of elements is limited to subjects and most adjunct PPs. Objects and PP arguments cannot be topicalized if the verb bears active morphology.

⁵ Keenan’s strong vs. weak topicalization may be parallel to what Aissen (1992) calls external and internal topics.

⁶ The particle *dia* also occurs in the following construction, a type of pseudo-cleft.

- (i) Ny manasa lamba dia Rakoto.
 det AT.wash cloth top Rakoto
 ‘The one who is washing clothes is Rakoto.’

I leave this for further research, but suggest that in (i) a headless relative has fronted from the subject position. *Rakoto* is a nominal (equative) predicate (it can take negation, for example). Note that the interpretation of (i) is parallel to a cleft construction.

- (ii) Rakoto no manasa lamba.
 Rakoto foc AT.wash cloth
 ‘It’s Rakoto who is washing clothes.’

See below for more discussion of clefts. The difference between (i) and (ii) deserves further investigation. Clearly unrelated to topicalization are the uses of *dia* as a coordinating conjunction, a temporal adverb meaning ‘and then’, and a superlative marker.

- (7) a. Rasoa dia nanapaka bozaka omaly.
 Rasoa top pst.AT.cut grass yesterday
 ‘As for Rasoa, she cut grass yesterday.’
- b. Omaly dia nanapaka bozaka Rasoa.
 yesterday top pst.AT.cut grass Rasoa
 ‘Yesterday, Rasoa cut grass.’
- c. Tamin’ny antsy dia nanapaka bozaka Rasoa.
 pst.P.gen.det knife top pst.AT.cut grass Rasoa
 ‘With the knife, Rasoa cut grass.’
- d. * Ity radara ity dia nanao haingana (azy) Rasoa.
 this radar this top pst.AT.do quickly (3(acc)) Rasoa
 ‘This radar, Rasoa built (it) quickly.’
- e. * Hoan’ny vahiny dia nanolotra vary Rakoto.
 for.gen.det guest top pst.AT.offer rice Rakoto
 ‘To the guests, Rakoto offered rice.’

These data indicate that topicalization shows the usual extraction restrictions, common to many western Austronesian languages.

If there is a focus in the clause, however, topicalization is much less restricted. (8) illustrates topicalization of a subject, object, benefactive and instrumental.⁷ (8) also shows that with topic>focus, the topic must be doubled by a resumptive pronoun unless it is the subject ((8a)).

⁷ Recalling the discussion in chapter 2, the question arises whether material themes and instruments topicalize from the DP position or the PP position. (8d) shows topicalization from the PP position, which seems to be the only possibility. Similar results obtain for material themes.

- (i) a. * Ny bozaka dia ny mpiasa no nanafo azy ny trano.
 det grass top det worker foc pst.AT.roof 3(acc) det roof
 ‘As for the grass, it’s the workers who roofed it onto the house.’
- b. Ny bozaka dia ny mpiasa no nanafo ny trano taminy.
 det grass top det worker foc pst.AT.roof det roof pst.P.3(gen)
 ‘As for the grass, it’s the workers who roofed the house with it.’

A proper investigation of topics should explain the contrast in (i).

Chapter 4

- (8) a. I Ketaka dia tany Betafo no nipetraka (*izy)
 Ketaka top pst.there Betafo foc pst.AT.live (3(nom))
 tamin'ny taona lasa.
 pst.P.gen.det year gone
 'As for Ketaka, it's in Betafo that she lived last year.'
- b. Ny vary dia izaho no nanolotra *(an'io) hoan'ny vahiny.
 det rice top 1sg(nom) foc pst.AT.offer (acc.it) for.gen.det guest
 'As for the rice, it's me who offered it to the guests.'
- c. Ny vahiny dia izaho no nanolotra vary *(ho azy).
 det guest top 1sg(nom) foc pst.AT.offer rice (for 3(acc))
 'As for the guests, it's me who offered them rice.'
- d. Ny antsy dia Rakoto no nandidy ny hena *(taminy).
 det knife top Rakoto foc pst.AT.cut det meat (pst.P.3(gen))
 'As for the knife, it's Rakoto who cut the meat with it.'

Note, however, that the topicalized elements are all DPs. PPs are not grammatical, in contrast to the examples in (7).

- (9) a. * Tany Fianarantsoa dia ny mahantra no mipetraka
 pst.there Fianarantsoa top det poor foc AT.live
 amin'ny trano tomboka (tany).
 P.gen.det house earth (pst.there)
 'As for F, it's poor people who live in dirt houses there.'
- b. * Tamin'ny antsy dia Rasoana no nanapaka bozaka (taminy).
 pst.P.gen.det knife top Rasoana foc pst.AT.cut grass (pst.P.3(gen))
 'As for the knife, it's Rasoana who cut grass with it.'

Summing up, we have the following differences between a simple topic and topic combined with focus.

- (10) XP dia
- a. XP must be “extractable” (e.g. subject or adjunct)
 - b. *resumptive pronouns
 - c. XP can be a range of categories (e.g. DP, PP)
- (11) XP dia YP no ...
- a. XP need not be extractable (e.g. may be object)
 - b. resumptive pronouns allowed (for objects)⁸
 - c. XP must be a DP

To account for this difference, I suggest that only in the cases of simple topicalization is there actual movement of the topicalized element to [Spec, TopicP]. Descriptively, movement to the topic position is blocked by the presence of an XP in [Spec, FocusP] - a Relativized Minimality violation. As well as the movement strategy, however, there is base generation in [Spec, TopicP]. Base generation requires the presence of resumptive pronouns (with the exception of subjects). With base generation, the range of topics is much freer since no movement is involved. On the other hand, since resumptive pronouns in Malagasy are only DPs, the base generation strategy is limited to DPs. A superficially similar split in topicalization strategies is apparent in English. (12a) exhibits movement characteristics, while (12b) arguably involves base generation of the topicalized constituent, *Eve* (Chomsky 1977).

- (12) a. Eve, Felix really likes.
 b. Eve, Felix really likes her.

Note, finally, that movement in Malagasy is “preferred” to base generation. In other words, if movement is possible (as when there is no focus), base generation is not an option. Hence base generation is something of a “last resort” strategy and not available in sentences equivalent to (12b).⁹

⁸ Even DP adjuncts are never associated with resumptive pronouns.

(i) Io maraina io dia i Ketaka no nanapaka bozaka (*tamin'izany fotoana izany).
 this morning this top Ketaka foc pst.AT.cut grass (pst.P.gen.that time that)
 ‘That morning, it was Ketaka who cut grass.’

⁹ This strategy is limited to topicalization, however. As far as I am aware, no other extraction process in Malagasy allows free extraction in combination with resumptive pronouns.

Chapter 4

2.4 Focus

In Malagasy, focus is expressed by a cleft. (In section 4 below, I provide arguments for the label “focus”.) Like topics, the focussed element is fronted and followed by a particle, in this case *no*. Along with topicalization, focus is one of a number of movement transformations that are sensitive to subjects. Objects may not directly cleft. Instead, the object is promoted to subject with passive and then fronted for a cleft.¹⁰

- (13) a. * Lamba_i no manasa t_i amin’ny savony Rakoto.
cloth foc AT.wash P.gen.det soap Rakoto
‘It’s clothes that Rakoto washes with the soap.’
- b. Ny lamba_i no sasan-dRakoto t_i amin’ny savony t_i.
det cloth foc TT.wash.gen.Rakoto P.gen.det soap
‘It’s the clothes that are washed by Rakoto with the soap.’

Unlike internal arguments, most adjuncts can be clefted in any voice (AT, TT, CT).^{11,12}

- (14) a. Amin’ny savony_i no manasa lamba t_i Rakoto.
P.gen.det soap foc AT.wash cloth Rakoto
‘It’s with the soap that Rakoto washes clothes.’
- b. Amin’ny savony_i no sasan-dRakoto t_i ny lamba.
P.gen.det soap foc TT.wash.gen.Rakoto det cloth
‘It’s with the soap that the clothes are washed by Rakoto.’

¹⁰ The judgements for (13a,b) are not affected by the presence or absence of the determiner. (13b), for example, is equally grammatical with or without the determiner.

¹¹ In the previous chapter we saw some exceptions to this generalization.

¹² Malagasy differs from other languages in Austronesian by clefting adjuncts. Most commonly (e.g. in Tagalog, Malay), adjuncts are merely fronted without a cleft marker. This is not possible in Malagasy; the cleft marker is obligatory (but see (38) below for some apparent counterexamples).

- (i) Tany Ambositra *(no) mipetraka Rasoa.
pst.there Ambositra (foc) AT.live Rasoa
‘It’s in Ambositra that Rasoa lives.’
- (ii) Aiza *(no) manasa lamba Rakoto?
where (foc) AT.wash cloth Rakoto
‘Where is Rakoto washing clothes?’

- c. Amin'ny savony_i no anasan-dRakoto lamba t_i t_i.
 P.gen.det soap foc CT.wash.gen.Rakoto cloth
 'It's the soap that is used by Rakoto to wash the clothes.'

In (14c), the adjunct is clefting as a subject. In other words, CT promotes the adjunct to subject and clefting occurs from this position. Chapter 3 provides an analysis of CT and of the occurrence of the preposition in clefts such as (14c). Note that *wh*-movement is a sub-type of focus movement. Thus (15) is parallel in all relevant respects to (13b).

- (15) Inona_i no sasan-dRakoto t_i amin'ny savony t_i?
 what foc TT.wash.gen.Rakoto P.gen.det soap
 'What is washed by Rakoto with the soap?'

In many languages, *wh*-movement is to a focus position (e.g. Italian, Hungarian). In this chapter, I will concentrate on non-*wh* clefts, although data from *wh* clefts will be considered (see section 5.6 in particular).

Unlike topics, focussed elements are never associated with resumptive pronouns. This restriction is illustrated in the following examples.

- (16) a. * Ny trano tomboka no mipetraka (aminy) ny mahantra.
 det house earth foc AT.sit (P.3(gen)) det poor
 'It's earth houses that poor people live in (them).'
- b. Amin'ny trano tomboka no mipetraka (*aminy) ny mahantra.
 P.gen.det house earth foc AT.sit (P.3(gen)) det poor
 'It's in earth houses that poor people live.'
- c. Ny mahantra no mipetraka amin'ny trano tomboka (*izy ireo).
 det poor foc AT.sit P.gen.det house earth (3(nom) pl)
 'It's poor people who live in earth houses.'

A similar pattern obtains in Italian: resumptive clitics are obligatory for topics and incompatible with focussed constituents (Rizzi (1997)). Since I associate the presence of resumptive pronouns in Malagasy with base generation, I believe this difference between topic and focus stems from

the fact that the latter always involves movement.¹³

Thus far we have seen clear evidence for TopicP dominating FocusP (see examples in (8)). What evidence is there for another topic position?

2.5 *The bodyguard*

As discussed by Keenan (1976), there are instances of apparent multiple topics and multiple foci. Examples are provided in (17).

- (17) a. Omaly i Soa dia nandoko ny tranony.
yesterday Soa top pst.AT.paint det house.3(gen)
'Yesterday, Soa painted her house.'
- b. Omaly i Soa no nandoko ny tranony.
yesterday Soa foc pst.AT.paint det house.3(gen)
'It was yesterday that Soa painted her house.'

He refers to these as "the bodyguard condition".

(18) **Bodyguard Condition** (Keenan (1976)):

when a non-subject is fronted in a cleft or by topicalization, it can optionally be accompanied by the grammatical subject

Descriptively, subject fronting being preferred, the adjunct can "piggy back" on the subject. The bodyguard condition is limited to a single adjunct and the (matrix) subject.

(17a) and (17b) in fact have different properties and I will argue that only the latter is a bodyguard construction. (17a) is an example of iterated topic projections, parallel to Italian. As initial evidence in favour of this approach, note that the order of topics in (17a) may be reversed, as in (19a), although the result is slightly degraded. This is not possible with the focus construction in (17b), as illustrated in (19b), which is completely ungrammatical.

¹³ Rizzi (1997) accounts for this difference by claiming that focalization is truly quantificational, but topicalization is not. Note, however, that since the Italian and the Malagasy data do not align perfectly (e.g. neither focus nor topic induce weak cross-over, quantified DPs can be focus or topic), I cannot adopt Rizzi's account of the distinction between topic and focus, which I leave as a stipulation.

- (19) a. ? I Soa omaly dia nandoko ny tranony.
 Soa yesterday top pst.AT.paint det house.3(gen)
 ‘Soa, yesterday, she painted her house.’
- b. * I Soa omaly no nandoko ny tranony.
 Soa yesterday foc pst.AT.paint det house.3(gen)
 ‘It was Soa yesterday who painted her house.’

As further evidence that multiple topics are possible, consider the following example.

- (20) Rahampitso ity antsy ity dia i Soa no hanapaka bozaka aminy.
 tomorrow this knife this top Soa foc fut.AT.cut grass P.3(gen)
 ‘Tomorrow, this knife, it’s Soa who will cut grass with it.’

Thus the *dia* topic may be iterated (although only one *dia* particle is possible) and there are no particular restrictions (other than those mentioned in 2.3) on what may appear in these positions.

For (17b), on the other hand, I suggest that the “bodyguard” (*i Soa*) is in a lower topic position, c-commanded by the focus position. The bodyguard, unlike the *dia* topic, is restricted to subjects. In section 5.3.3, I will show that the bodyguard has topic properties; for the moment, let us assume this to be the case. (21) illustrates the topic>focus>topic word order.¹⁴

- (21) [Ny lovia maloto]_{TOP} dia [isan’andro]_{FOC} [Rabe]_{TOP} no manasa azy ireo.
 det dish dirty top each’d day Rabe foc AT.wash 3(acc) pl
 ‘As for the dirty dishes, it’s every day that Rabe washes them.’

Thus Malagasy has both a “high” topic (with *dia*) and a “low” topic (bodyguard), providing support for the extended CP proposed by Rizzi. In other words, the bodyguard corresponds to a fixed position, rather

¹⁴ Analyzing the bodyguard as a topic clearly points away from treating *no* as a focus marker, *per se*, since the XP that precedes it is not always focus. I return to the problem of labelling *no* in 3.4.

than being an “extra” position licensed by topic or focus. Distributionally, the two topic positions have very different properties. The “low” topic is always the subject. The “high” topic, on the other hand, can be filled by almost any element in the clause: subject, object, oblique, as was discussed in section 2.3. Moreover, I claim that the bodyguard is restricted to cleft constructions. I will address the unusual properties of the bodyguard in section 5.5.

2.6 Malagasy clause-structure

The preceding sections have shown that various elements (e.g. topic, focus) may appear in the left periphery of the clause in Malagasy. As mentioned in chapter 1, recent work on phrase structure in Malagasy has adopted a “predicate fronting” approach to VOS order (e.g. Pensalfini (1995); Pearson (1996b); Rackowski (1998); Rackowski and Travis (to appear)). Under this analysis, the VP (or a similar XP) raises to a specifier position above the subject DP. For the sake of clarity, let us say that the subject raises to [Spec, AgrP] and that the VP raises to [Spec, TP], where TP dominates AgrSP.¹⁵ Combining this analysis with the proposed view of topic and focus, we get the following picture of the Malagasy clause.¹⁶

¹⁵ I am using AgrP as a convenient label for the subject position.

¹⁶ Below I will slightly modify this tree and argue that the XP in [Spec, FocusP] is in fact a predicate. The lower topic position is limited to subjects and, therefore, is always a DP.

(22)

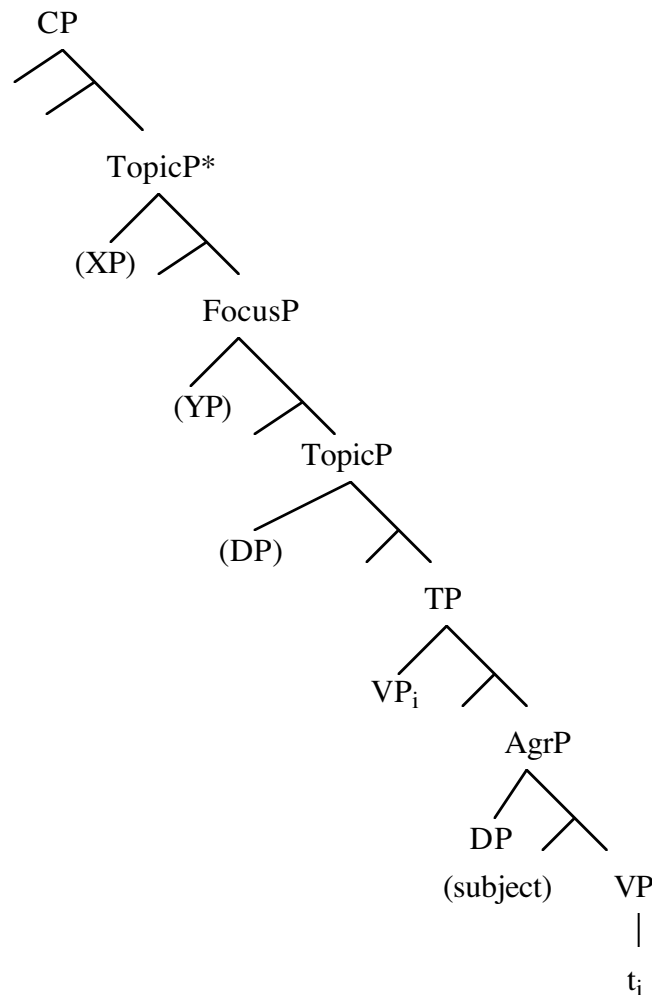

In a standard declarative clause, the VP (or some extended projection) will be in the highest (filled) specifier position. In general, movement of XPs is driven by feature-checking requirements of heads. For example, raising of the predicate to [Spec, TP] satisfies the EPP features of T° .¹⁷ Similarly, focussed and topicalized elements satisfy the features of Focus° and Topic° , respectively. Along with Rizzi (1997), I assume that the topic and focus positions are not projected unless “activated”. That is, if there are no topics or focussed elements in the clause, the TopicP and FocusP projections will be absent.

Summing up, this section has provided an overview of the left periphery in Malagasy. I will now consider in more detail the focus construction, which has the form of a cleft.

¹⁷ See section 5 in chapter 3 for some speculations on the EPP in Malagasy.

3 The structure of clefts

This section is devoted to the structure of the cleft in Malagasy. As we have already seen, the clefted element appears to the left of the verb and is followed by the particle *no*, glossed as ‘foc’ for ‘focus’.¹⁸

- (23) Rakoto no manasa lamba.
Rakoto foc AT.wash cloth
‘It’s Rakoto who washes clothes.’

In the discussion below, I will use the following terminology to describe clefts: the “pivot” (*Rakoto* in (23)) and the “presuppositional clause” (the remainder of the sentence) (Jackendoff (1972)).

The structure of clefts has been investigated in many languages. I will discuss some of the proposals and their relevance to Malagasy. I will show that Malagasy clefts have an equative structure: the pivot is a predicate and the presuppositional clause is a headless relative in subject position.

- (24) [pivot_i [[DP presuppositional clause] t_i]]

In other words, the structure bears some similarities to a pseudo-cleft. I begin with some previous analyses of focus constructions.

3.1 *It-clefts*

Chomsky (1977) proposes the following structure for English clefts, where XP, the pivot, is adjoined to CP.

- (25) a. It is [CP [this book] [CP OP that I really like t]]

¹⁸ In fact, as I will argue below, *no* is not a focus marker, per se. However, since it is always present in focus constructions, the label ‘foc’ seems most appropriate at this point.

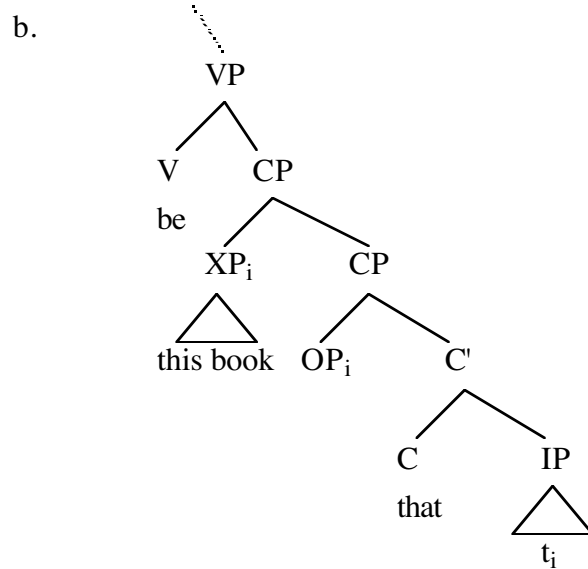

Alternatively, the pivot could appear in the specifier of a separate projection, FocusP. This has been suggested for Italian and Hungarian focus constructions (Rizzi (1997); É. Kiss (1998)).¹⁹

(26)

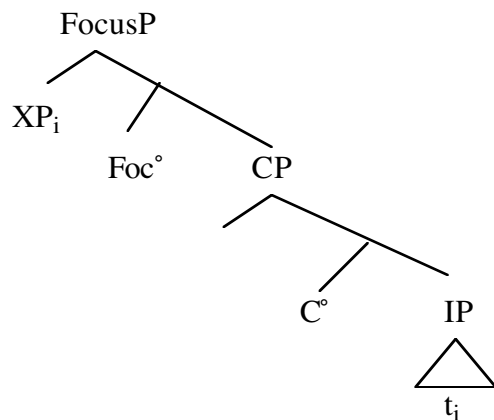

The difference between (25) and (26) lies in the position of the pivot: adjoined or in a specifier position. Moreover, both Rizzi and É. Kiss argue for direct A-bar movement of the pivot to the focus position. For Chomsky, however, operator movement within the presuppositional clause accounts for the A-bar movement properties of clefts (see Chomsky (1977) for discussion).

¹⁹ In Hungarian, the focus position is immediately pre-verbal. Hence, É. Kiss does not have any projections between FocusP and VP.

Adapting these proposal to Malagasy clefts, we have the following trees.²⁰

- (27) a. Rakoto no manasa lamba.
 Rakoto foc AT.wash cloth
 ‘It’s Rakoto who washes clothes.’

b. Chomsky-tree

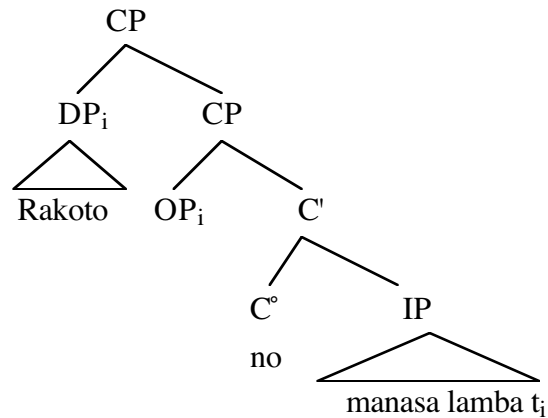

c. Rizzi/É.Kiss-tree

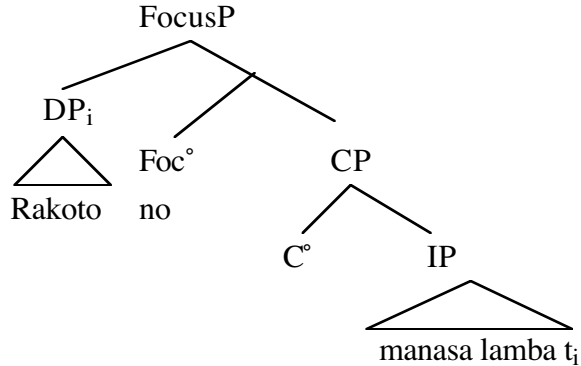

In (27b), the pivot is base generated and movement obtains via the operator-variable pair. Positing an analysis where there is direct movement to the pivot position, as in (27c), is hard to motivate in Malagasy. If movement were to occur directly from the subject position to the pivot, we would expect the pivot position to have the same restrictions as the subject position. As already seen in chapter 3, however, the elements that can appear in the pivot position are a superset of those

²⁰ The position of the focus particle *no* is immaterial at this point, either in C° or Foc°.

that can be subjects. For example, while indefinite (nonspecific) subjects are ungrammatical, it is quite common for the pivot to lack a determiner.

- (28) a. Milalao baolina *(ny) zazavavy.
AT.play ball (det) girl
'The girls are playing ball.'
- b. (Ny) zazavavy no milalao baolina.
(det) girl foc AT.play ball
'It's (the) girls who are playing ball.'

Similarly, the ungrammaticality of PP subjects contrasts with the well-formedness of PP clefts. In chapter 3, we considered many examples parallel to (29).

- (29) a. Andafihan'i Soa ny atody (*amin') ny bozaka.
CT.pad.gen.Soa det egg (P.gen) det grass
'Soa pads the egg with the straw.'
- b. (Amin') ny bozaka no andafihan'i Soa ny atody.
(P.gen) det grass foc CT.pad.gen.Soa det egg
'It's with the straw that Soa pads the egg.'

In fact, some CT clauses must be realized as a cleft due to restrictions on the subject position. As discussed in chapter 3, (30a) is ungrammatical because the price nominal (a non-referential DP) is not permitted in subject position; once clefted, the example is acceptable, as in (30b).

- (30) a. * Nividianany hena valopolo.
pst.CT.buy.3(gen) meat 80
- b. Valopolo no nividianany hena.
80 foc pst.CT.buy.3(gen) meat
'It's for 80 (ariary) that she bought meat.'

Thus in order for direct movement to be valid for Malagasy clefts, it

would require the additional stipulation of allowing indefinites, PPs, and non-referential DPs to move through the subject position as long as they do not remain there. This is not an unreasonable solution, but the Chomsky analysis avoids this problem as it is not the pivot itself that moves, but an empty operator. Although this approach appears adequate, I will now consider a different cleft structure that is more easily motivated for Malagasy.

3.2 Pseudo-clefts

The structures presented above equate Malagasy clefts to English *it*-clefts and focus fronting in Romance and Hungarian. Within the Austronesian tradition, however, researchers have pointed out that clefts in these languages bear some similarities to equational clauses with a headless relative as the subject. For some analyses, see Kroeger (1993) and Richards (1996) on Tagalog, Georgopoulos (1991) on Palauan and Cole, Hermon and Aman (to appear) on Malay.²¹ From this perspective, the pivot is in fact the predicate and the presuppositional clause is the subject. Consequently, clefts in Austronesian bear a close resemblance to (English) pseudo-clefts (e.g. *what Rakoto washed was the clothes*). (31) is the structure proposed by Georgopoulos (and Kroeger) and (32) is argued for by Cole, Hermon and Aman (to appear) (henceforth, CHA).

(31) Georgopoulos-tree

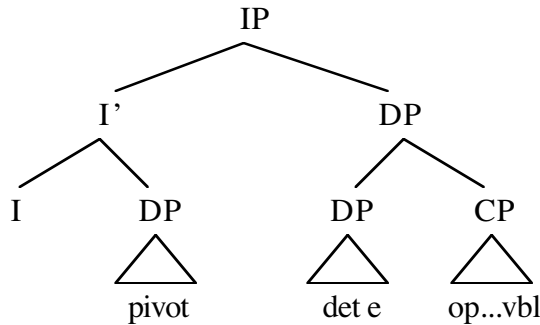

²¹ Pearson (1996c: fn 17) posits a similar analysis for Malagasy clefts.

(32) CHA-tree

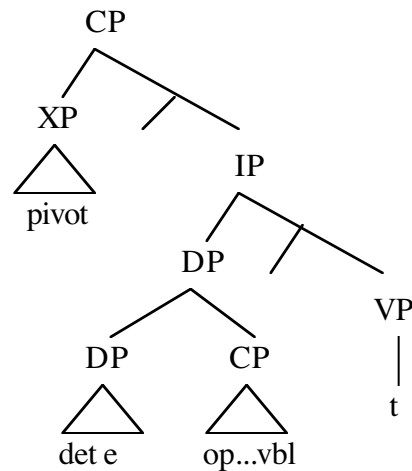

In both (31) and (32), there is a predication relation between the pivot and the operator in the relative clause, similar to the Chomsky-style analysis in (27b). The main difference between (31)/(32) and (27b) is that in the former the pivot is a predicate, not an argument. (31) and (32) can be distinguished in the position of the pivot: in (31), the pivot remains in the (clause-initial) predicate position, while in (32), it moves to [Spec, CP]. I will adopt the analysis of clefts in (32), with some minor modifications. In particular, I argue that the pivot is a predicate that moves into the specifier of a functional projection, FocusP (not CP). The presuppositional clause is a headless relative in the subject position.

Interestingly, the structure in (32) is strikingly parallel to recent proposals for deriving predicate-initial word order, mentioned in the introductory chapter and again in section 2.6. Under this analysis, structures along the lines of (32) are prevalent in Malagasy. To capture interpretational differences (in particular, the focus reading for clefts), I suggest that the difference between a cleft and a regular clause lies in the final position of the VP/predicate: [Spec, FocusP] for clefts and [Spec, TP] for “normal” clauses. See section 4 for some discussion of the special focus interpretation for pivots. (33b) illustrates the structure of the cleft in (33a): the predicate moves to [Spec, TP] for EPP and then to [Spec, FocusP] for the focus interpretation.

- (33) a. [predicate Ny zazavavy] [subject no milalao baolina].
 det girl foc AT.play ball
 (lit.) ‘The ones who are playing ball are the girls.’

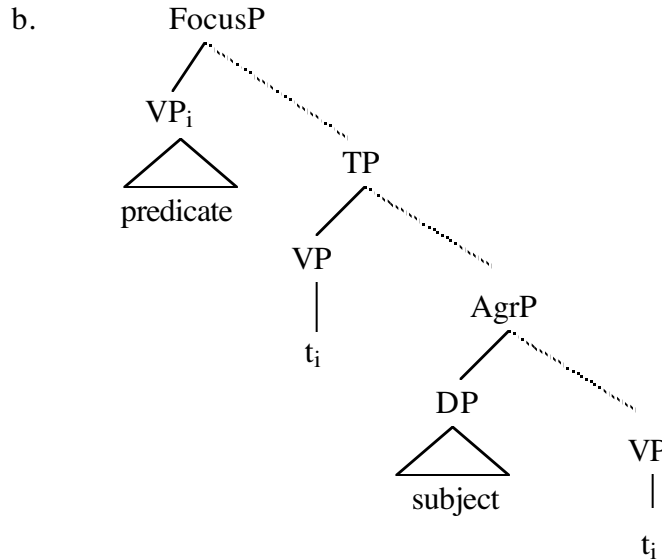

(34b), on the other hand, represents a standard clause. The predicate moves to [Spec, TP], giving VOS word order.

- (34) a. [predicate Milalao baolina] [subject ny zazavavy].
 AT.play ball det girl
 ‘The girls are playing ball.’

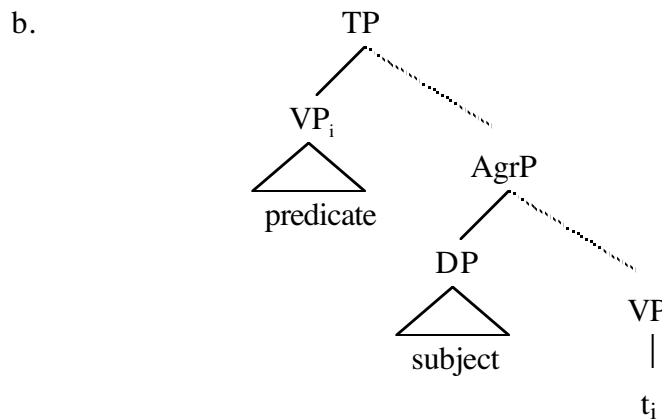

I now turn to some evidence in favour of the structure in (33b) for clefts.

3.3 Pivot=predicate

Turning first to the pivot, for both Georgopoulos and CHA, the pivot originates as a predicate. In Georgopoulos' structure in (31), there is no movement of the pivot; it remains in the clause-initial position, consistent with Palauan predicate-initial word order. Malay, on the other hand, is a subject-initial language that also has clause-initial clefts. CHA therefore propose that the pivot moves into [Spec, CP], as shown in (32).²²

In these languages, the pivot does have predicate-like properties. For example, the Palauan examples in (41) below show that the pivot takes the subject agreement marker *ng*. Turning to Malagasy, most pivots are DPs or PPs, which are also possible as matrix predicates.²³

- (35) a. Any Antananarivo no mipetraka i Ketaka.
 there Antananarivo foc AT.live Ketaka
 'It's in Antananarivo that Ketaka lives.'
- b. Any Antananarivo i Ketaka.
 there Antananarivo Ketaka
 'Ketaka is in Antananarivo.'

Moreover, a clefted DP can be negated, unlike argument DPs and like predicates (verbal or other). Thus the pivot in (36a) can take negation and patterns with the nominal predicate in (36d). (36b,c) show that as arguments, DPs cannot be negated.

- (36) a. Tsy Rasoana no nanoroka an-dRakoto.
 neg Rasoana foc pst.AT.kiss acc-Rakoto
 'It's not Rasoana who kissed Rakoto.'
- b. * Nanoroka tsy an-dRakoto Rasoana.
 pst.AT.kiss neg acc-Rakoto Rasoana

²² Due to predicate-initial order, in both Malagasy and Palauan the movement of the pivot to [Spec, FocusP] is string-vacuous.

²³ In chapter 3 section 2.4, I provide an account for restrictions on what can be a pivot.

Chapter 4

- c. * Nanoroka an-dRakoto tsy Rasoana.
pst.AT.kiss acc-Rakoto neg Rasoana
‘Rasoana has not kissed Rakoto.’
- d. Tsy mpianatra Rasoana.
neg student Rasoana
‘Rasoana is not a student.’

Similarly, the pivot may be preceded by the verbal particle *toa* ‘seems’. As shown in (37a), *toa* normally precedes the predicate.

- (37) a. Toa nanoroka an-dRakoto Rasoana.
seem pst.AT.kiss acc-Rakoto Rasoana
‘Rasoana seems to have kissed Rakoto.’
- b. Toa Rasoana no nanoroka an-dRakoto.
seem Rasoana foc pst.AT.kiss acc-Rakoto
‘It seems to be Rasoana who kissed Rakoto.’

The above data indicate that the pivot has a similar distribution to predicates.²⁴

For further evidence that the pivot is a predicate, recall that *wh*-questions are formed by clefts (see section 2.4). Note that in certain cases, however, *wh*-elements can be matrix predicates without clefting.

- (38) a. Iza ianao?
who 2sg(nom)
‘Who are you?’

²⁴ In a cleft, both *tsy* and *toa* can also appear on the embedded predicate. Thus these are not simply clause-initial particles.

- (i) a. Rasoana no tsy nanoroka an-dRakoto.
Rasoana foc neg pst.AT.kiss acc-Rakoto
‘It’s Rasoana who didn’t kiss Rakoto.’
- b. Rasoana no toa nanoroka an-dRakoto.
Rasoana foc seem pst.AT.kiss acc-Rakoto
‘It’s Rasoana who seems to have kissed Rakoto.’

- b. Inona ireto vato ireto?
 what these stone these
 ‘What are these stones?’

In order to account for the difference between examples like (38) and clefts, I suggest that in (38) the *wh*-elements are in the regular fronted predicate position (e.g. [Spec, TP]), not in [Spec, FocusP] (the trees in (33) above illustrate the two positions). Clearly, there is no incompatibility between *wh*-elements and the predicate position. It is therefore not unreasonable to argue that when in clefts, *wh*-elements are also predicates.

Interestingly, in cases such as (38), clefting is *not* possible, as shown by the ungrammaticality of (39).

- (39) a. * Iza no ianao?
 who foc 2sg(nom)
 ‘Who are you?’
- b. * Inona no ireto vato ireto?
 what foc these stone these
 ‘What are these stones?’

I do not have a complete explanation for the contrast between (38) and (39). I tentatively suggest that the ungrammaticality of (39) derives from some incompatibility between a headless relative and a definite DP (names, pronouns, etc.). The meaning for (39a) would be ‘the one who is you is who?’, a decidedly odd construction.

Summing up, a range of data show that the pivot in a cleft patterns with predicates. I take this as evidence in favour of the structure in (33b), where the pivot moves to [Spec, FocusP] from the matrix predicate position.

3.4 Presuppositional clause=headless relative

Let us now examine the cleft structures in more detail. In both (31) and (32), the presuppositional clause has the structure of a headless relative. In a wide range of Austronesian languages, the cleft marker is a relative

clause marker or another nominal-marker. The following illustrate this for Malay, an SVO language (data from CHA).

- (40) a. [predicate Siapa]_i [subject **yang** kau nampak] t_i?
 who that you see
 ‘Who do you see?’
- b. [subject **Yang** kau nampak] [predicate Siti] (-lah).
 that you see Siti (foc)
 ‘The one you see is Siti.’
- c. [DP buku [CP **yang** John beli]]
 book that John bought
 ‘the book that John bought’

(40a) is a clefted question, marked by *yang* (glossed as ‘that’). (40b) illustrates *yang* as a headless relative marker. That *yang* can be used for regular (headed) relative clauses is shown in (40c).

In Palauan, the morpheme *a* is an all-purpose DP marker and precedes the presuppositional clause in a cleft. The data in (41) are from Georgopoulos (1991). (41a) illustrates the standard predicate-initial word order while (41b,c) are clefts. Note the presence of *a* in all examples.

- (41) a. [predicate Ng-mekelekolt] [subject **a** ralm].
 agr-cold R-water
 ‘The water is cold.’
- b. [predicate Ng-Basilia] [subject **a** mengaus er tia el tet].
 agr-Basilia R-weave P dem L bag
 ‘It’s Basilia who’s weaving this bag.’
- c. [predicate Ng-te’a] [subject **a** kileld-ii a sub]?
 agr-who R-pf-heat-3s soup
 ‘Who heated up the soup?’

As described by Georgopoulos, *a* always occurs before a DP. She

concludes that since the presuppositional clause in (41b,c) is marked with *a*, it is a free relative in the subject position.

The Malagasy *no* is somewhat mysterious by comparison as it is not used elsewhere in the language.²⁵ Hence this type of headless relative does not surface except in clefts. Free relatives, for example, use *izay* (which is also the relative clause marker).

- (42) Hahazo karama be izay miasa mafy.
 fut.AT.get salary big rel AT.work hard
 ‘Whoever works hard will make lots of money.’

I simply stipulate that the headless relative marked by *no* is restricted to equative clauses. Due to the similarities between clefts and relative constructions, I will assume that *no* is a nominal marker.²⁶ It is probably either a determiner or a complementizer. The two trees in (43) illustrate two possible structures of the headless relative in question. Since the precise position of *no* is not crucial to my analysis, I will not attempt to distinguish between these two possibilities.

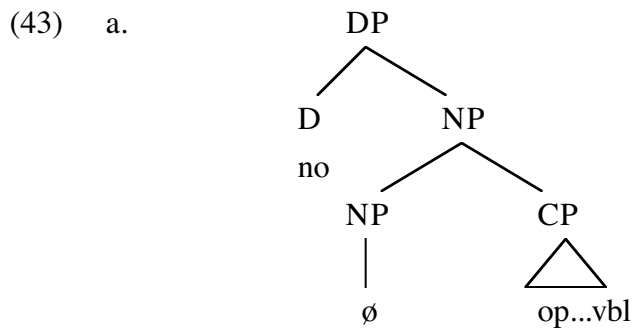

²⁵ Clearly unrelated is the past tense marker *no*. Another use of *no*, likely related to the focus construction is in the first clause of an *if...then* statement, when the second expresses a cause.

- (i) Izaho no tsy tonga, nisy raharaha nalehako.
 1sg(nom) foc neg arrived pst.AT.exist business pst.a.gone.1sg(gen)
 ‘If I didn’t come, it’s because business called me elsewhere.’

Finally, *no* appears in certain SVO contexts, where the subject is an indefinite pronoun.

- (ii) Na iza na iza (no) tsy mamafa lalana dia voasazy.
 or who or who (foc) neg AT.sweep road top voa.punish
 ‘Whoever doesn’t sweep the road will be punished.’

In (ii), *no* is optional and in fact some speakers prefer to omit it.

²⁶ In Sundanese, an Indonesian language, the relative clause marker is *nu* (Hardjadibrata (1985)). Malagasy and Sundanese are related, but not closely enough for this to be conclusive evidence, however. Malzac (1960) mentions that certain Malagasy grammarians believe *no* to be diachronically related to the determiner *ny*. He does not provide any references, however.

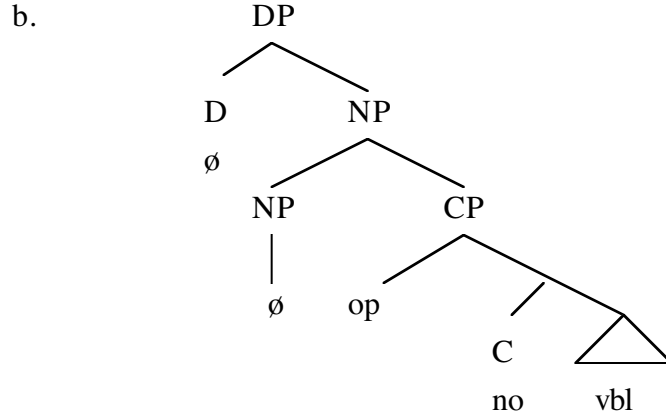

The fact that *no* is not a focus marker per se will be important once we examine multiple clefts. I will next discuss the interpretation of these headless relative structures.

3.5 Interpretation

In this section, I address the nature of the headless relative clause in the proposed structure of the cleft. In a cleft where the pivot corresponds to the subject, the headless relative means something like ‘the one/thing who/that...’.

- (44) Bakoly no manapaka bozaka.
 Bakoly foc AT.cut grass
 (lit.) ‘The one who is cutting grass is Bakoly.’

When something other than a subject is the pivot, however, the meaning shifts. Consider (45), which has a PP pivot.

- (45) Amin’ny antsy no manapaka bozaka i Bakoly.
 P.gen.det knife foc AT.cut grass Bakoly
 ‘It is with a knife that Bakoly is cutting grass.’

Here, the headless relative cannot mean ‘the one who is cutting grass’ for two reasons. First, the agent of cutting (*Bakoly*) is expressed within the relative. Second, assuming that clefts have an equative structure, it is somewhat odd to equate a PP with a nominal referring to an individual. I therefore suggest that in (45), the headless relative is interpreted as an

event nominal (like a gerund). In other words, (45) means ‘The event of Bakoly cutting grass was with a knife’.

This account may at first appear stipulative. In fact, however, zero nominals in Malagasy freely have either an event or an individual interpretation. Both readings are illustrated in (46).

- (46) a. Faly ny manapaka bozaka.
 happy det AT.cut grass
 ‘The ones who are cutting grass are happy.’
- b. Sarotra ny manapaka bozaka.
 difficult det AT.cut grass
 ‘Cutting grass is difficult.’

In (46a), the zero nominal clearly receives an individual reading. (46b), on the other hand, is a gerund-like zero nominal. It is therefore not unreasonable to suggest the event and the individual readings are also available for the headless relatives in cleft constructions.²⁷

Summing up, in this section, I have provided arguments for analyzing the Malagasy cleft as an equative construction. The pivot is in fact the matrix predicate and the presuppositional clause is a headless relative clause in the subject position. In section 4, I will motivate the claim that the pivot is interpreted as focus. I take this as evidence that the pivot appears in the specifier of a functional projection, [Spec, FocusP].

3.6 Interlude: *ve*

At this point, I will consider a Malagasy-particular test for the subject-predicate distinction. Looking at focus, this test initially points in favour of the above analysis of clefts. I will show, however, that once a range of data are considered, this test must be reconsidered. Although not directly relevant for the cleft construction, this section reveals previously unnoticed data that warrant analysis.

Keenan (1976) noted that certain particles appear immediately before the subject in a clause. Some examples are given below: the question particle *ve* (47a), the exclamative particle *anie* (47b) and the negative

²⁷ These two readings are available for active and circumstantial and passive verbs.

polarity item *intsony* (47c).

- (47) a. Manapaka bozaka **ve** i Bakoly?
 AT.cut grass Q Bakoly
 ‘Is Bakoly cutting grass?’
- b. Manapaka bozaka **anie** i Bakoly!
 AT.cut grass ex Bakoly
 ‘Is Bakoly ever cutting grass!’
- c. Tsy manapaka bozaka **intsony** i Bakoly.
 neg AT.cut grass NPI Bakoly
 ‘Bakoly is no longer cutting grass’

In what follows, I will consider the question particle *ve*.²⁸ I will show that contrary to previous claims *ve* is not a particle that marks off the right edge of the VP. Instead, I will show that it is a second position clitic.

Due to its position, *ve* is often used as a test for subject-hood and, indirectly, clause structure. Consider now a clefted clause. Comparing the position of *ve* in (48) and (47a) appears to indicate that the clefted element is the predicate and the remainder of the clause is the subject. This is precisely the evidence that Pearson (1996a) mentions in favour of a headless relative clause structure for clefts.

- (48) Bakoly **ve** no manapaka bozaka?
 Bakoly Q foc AT.cut grass
 ‘Is it Bakoly who is cutting grass?’

Let us next turn to an apparent multiple cleft (the bodyguard construction). In this case, *ve* surfaces between the first element and the

²⁸ The NPI *intsony* and the hortative *anie* do not have the same distribution as *ve*. These particles do appear to indicate the right edge of a VP, hence they can surface either with the pivot or in the presuppositional clause, which contains an embedded VP.

- (i) a. Tsy i Bakoly intsony no manapaka bozaka.
 neg Bakoly NPI foc AT.cut grass
 ‘It’s no longer Bakoly who is cutting grass.’
- b. I Bakoly no tsy manapaka bozaka intsony.
 Bakoly foc neg AT.cut grass NPI
 ‘It’s Bakoly who is no longer cutting grass.’

second.

- (49) Omaly **ve** Bakoly no nanapaka bozaka?
 yesterday Q Bakoly foc pst.AT.cut grass
 ‘Was it yesterday that Bakoly was cutting grass?’

Following the same reasoning, this datum would suggest that the second element, *Bakoly*, is contained within the subject position. In other words, the meaning of (49) would be something like ‘Was Bakoly’s cutting of grass yesterday?’. So far, these are reasonable conclusions.

Things become more complicated, however, once we turn to topicalization. Parallel to clefting, *ve* appears between the topic and the rest of the clause.

- (50) Bakoly **ve** dia manapaka bozaka?
 Bakoly Q top AT.cut grass
 ‘Bakoly, is she cutting grass?’

Moreover, if there is both a topic and a cleft, *ve* still surfaces immediately after the topicalized constituent.

- (51) Ity antsy ity **ve** dia Bakoly no nanapaka bozaka taminy?
 this knife this Q top Bakoly foc pst.AT.cut grass pst.P.3(gen)
 ‘This knife, did Bakoly cut grass with it?’

Should we conclude that in topicalization, the topic is a predicate?

I argue that this is not the correct conclusion. Topics, unlike focussed elements, do not pattern with predicates. As pointed out by Keenan (1976), topics are incompatible with negation and with the verbal particle *toa* ‘seems’.

- (52) a. * Tsy Rasoa dia nanoroka an-dRakoto.
 neg Rasoa top pst.AT.kiss acc-Rakoto
 ‘Not Rasoa who kissed Rakoto.’

- b. * Toa Rasoa dia nanoroka an-dRakoto.
 seem Rasoa top pst.AT.kiss acc-Rakoto
 ‘It seems that Rasoa, she kissed Rakoto.’

I take these data as showing that topics, unlike foci, are not predicates. Hence, *ve* does not consistently appear immediately following the matrix predicate. As should now be clear from examples (48)-(51), *ve* surfaces immediately following the first constituent in a clause, irrespective of the nature of that constituent. In other words, *ve* is a second position clitic.

Supporting evidence comes from SVO constructions. In certain contexts (like contrastive clauses), Malagasy allows SVO word order. In these cases, the question particle appears between the subject and the VP.

- (53) Ny mpianatra **ve** mamaky teny, ny mpampianatra **ve** mihaino?
 det student Q AT.read word det teacher Q AT.listen
 ‘Are the students reading, the teachers listening?’

Clearly, in this example *ve* does not mark off the right edge of the VP. Rather, it is in second position, in this case immediately following the subject DP. That the DP in initial position is not a predicate can be seen by the impossibility of negation.

- (54) * Tsy ny mpianatra mamaky teny, tsy ny mpampianatra mihaino.
 neg det student AT.read word neg det teacher AT.listen

Thus it is incorrect to claim that *ve* can be used as a positional test for the predicate.

To account for the positioning of *ve*, we could propose that *ve* is the head of the highest C projection, ForceP. This would capture the fact that the question particle marks the clause type (interrogative) (Cheng (1991)). As a clitic, *ve* then appears after the highest XP (predicate, focus, topic, etc.). Thus the placement of the question particle varies depending on the clause structure. Since the highest XP is usually the predicate phrase, *ve* does appear to mark the right edge of the predicate phrase. This is not the place for an analysis of second position cliticization. I therefore assume that as a clitic, *ve* is sensitive to both syntax (it appears after an XP,

not after a word) and prosody (it appears after the first XP in the clause, not in a particular syntactic position). (see Halpern and Zwicky (1996) for a recent collection of articles on this topic). Finally, note that second position clitics are common in western Austronesian languages. See Kroeger (1993) on Tagalog, where the Q particle *ba* is likely cognate with *ve*. The proposal for *ve* is therefore consistent with facts from this language family.

4 Cleft as focus

Above, I have claimed that clefting is a focus construction, without motivation. In this section I will show that the pivot in a cleft receives a particular interpretation, similar to focus in other languages. Hence it seems reasonable to refer to the cleft as a focus construction. Although I discuss some interpretational properties of focus, I will not provide a semantic analysis *per se*. Instead, the following discussion is simply intended to illustrate the properties of clefts as evidence in favour of treating the cleft as a focus construction. I take this as indirect evidence in favour of positing movement to a particular functional projection, FocusP.

The cleft construction in Malagasy has many of the properties associated with focus movement in other languages. The pivot is understood as contrastive and exhaustive. For the following, I draw on discussion by É. Kiss (1998). She defines “identificational focus” as the following:

- (55) The function of identificational focus: An identificational focus represents a subset of the set of contextually or situationally given elements for which the predicate phrase can potentially hold; it is identified as the exhaustive subset of this set of which the predicate phrase actually holds.

Semantically, identificational focus involves an operator-variable construction. For Hungarian, É. Kiss posits syntactic movement of the pivot to [Spec, FocusP] to set up the proper binding relation. In the structure I adopt for Malagasy, the pivot is not directly involved in binding a variable. Instead, the operator-variable pair is contained in the headless relative.

É. Kiss provides some tests for distinguishing identificational focus

(which involves movement to a functional projection) from information focus (which does not involve movement). These tests will show that the Malagasy cleft expresses identificational focus. Information focus is often associated with pitch accent and does not have the same semantic force as identificational focus. As defined, identificational focus expresses exhaustive identification. Hence, the answers in (56b,c) to the question in (56a) have different meanings.

- (56) a. Nandeha taiza ianao?
 pst.AT.go pst.where 2sg.nom
 ‘Where did you go?’
- b. Nandeha tany Ambositra aho.
 pst.AT.go pst.there Ambositra 1sg.nom
 ‘I went to Ambositra.’
- c. Tany Ambositra no nandeha aho.
 pst.there Ambositra foc pst.AT.go 1sg.nom
 ‘It was to Ambositra that I went.’

(56b) does not exclude the possibility that I went to other places as well as Ambositra. The cleft construction in (56c), however, is an exhaustive answer; Ambositra is the only destination.

Similarly, consider the following pairs.²⁹

- (57) a. Novidin’i Bakoly ny satroka sy ny kiraro.
 pst.TT.buy.gen.Bakoly det hat and det shoe
 ‘Bakoly bought a hat and shoes.’
- b. Novidin’i Bakoly ny satroka.
 pst.TT.buy.gen.Bakoly det hat
 ‘Bakoly bought a hat.’

²⁹ É. Kiss attributes this test to Szabolcsi (1981). The judgements in (57) do not change if the verb is in AT. I use TT in (57) to provide minimal pairs with (58), where TT is necessary to allow clefting of the logical object.

- (58) a. Ny satroka sy ny kiraro no novidin'i Bakoly.
det hat and det shoe foc pst.TT.buy.gen.Bakoly
'It's a hat and shoes that Bakoly bought.'
- b. Ny satroka no novidin'i Bakoly.
det hat foc pst.AT.buy.gen.Bakoly
'It's a hat that Bakoly bought.'

As in the English equivalents, the sentence in (57b) is a logical consequence of the one in (57a). On the other hand, (58b) is not a logical consequence of (58a). In fact, (58b) contradicts (58a). Hence, the cleft construction in (58) passes the test of exhaustivity.

Exhaustivity is further illustrated with the following test (as above, this test was inspired by É. Kiss (1998)). Clefts carry a presupposition of exhaustivity. In (59b), the negation is interpreted denying the exhaustivity introduced in (59a).

- (59) a. A: Ny satroka no novidin'i Bakoly.
det hat foc pst.TT.buy.gen.Bakoly
'It's a hat that Bakoly bought.'
- b. B: Tsia, ny kiraro no novidiny.
no det shoe foc pst.TT.buy.3(gen)
'No, it's shoes that she bought.'

By (59b), speaker B corrects speaker A and indicates that Bakoly only bought shoes, not a hat. In argument positions (such as subject and object), there is no such presupposition and hence the negation in (60b) is not appropriate in response to (60a). In what follows, '#' marks examples that are grammatical, but pragmatically odd in context.

- (60) a. A: Novidin'i Bakoly ny satroka.
pst.TT.buy.gen.Bakoly det hat
'Bakoly bought a hat.'

Chapter 4

- b. # B: Tsia, novidiny ny kiraro koa.
no pst.TT.buy.3(gen) det shoe also
'No, it's also shoes that she bought.'

This test will be used to investigate apparent multiple clefts in section 5.3.2.

Finally, there are certain distributional restrictions on the elements that can appear in the focus position.

- (61) a. * Bakoly koa no nandeha tany Ambositra.
Bakoly also foc pst.AT.go pst.there Ambositra
* 'It's also Bakoly who went to Ambositra.'
- b. * Na ny mpianatra votsavotsa aza no nahazo isa tsara.
or det student weak even foc pst.AT.get number good
* 'It's even the weak students who got good grades.'
- c. * Na iza na iza no mahavita izany.
or who or who foc AT.done that
* 'It's anyone who can do that.'

These elements appear to have some semantic clash with exhaustive identification. For example, the import of 'also' in (61a) is to assert that someone else went to Ambositra. Hence the meaning of this adverb conflicts with the presupposition of exhaustivity. Similar considerations hold for 'also'. Indefinites like *na iza na iza* 'anyone' in (61c) also do not express the exclusion necessary in a cleft. Since DPs with these semantic features are not permitted in a cleft, we see that the cleft position is associated with a particular interpretation, in this case exhaustivity.

Note, however, that a clefted *koa* 'also' is possible in certain contexts, just as in English. A cleft with *koa* 'also' identifies a member of the relevant set in addition to the member previously identified, with the rest of the set still excluded. (62b) is therefore a possible reply to the statement (62a).

- (62) a. A: Ny satroka no novidin'i Bakoly.
det hat foc pst.AT.buy.gen.Bakoly
'It's a hat that Bakoly bought.'

- b. B: Ny kiraro koa no novidiny.
det shoe also foc pst.AT.buy.gen.3
'It's also shoes that she bought.'

Here, Speaker A identifies a hat as a member of the set of things bought by Bakoly, excluding all other possible items. Speaker B adds shoes to this set, again excluding other items.

The above data show that in a cleft, the displaced element receives a special focus interpretation, "identificational focus". I therefore conclude that the cleft position is associated with focus features. Furthermore, like Hungarian, Malagasy clause structure includes a functional projection that hosts focussed elements.³⁰ Now that we have explored simple focus, I turn to apparent multiple foci.

5 Multiple clefts

As an unusual twist to the cleft construction, Malagasy allows two elements to be fronted.

- (63) Omaly Rasoa no nanoroka an-dRakoto.
Yesterday Rasoa foc pst.AT.kiss acc-Rakoto
'It was yesterday that Rasoa kissed Rakoto.'

As mentioned in 2.5, this has been described by Keenan (1976) as the "bodyguard condition" (repeated below).³¹

- (64) **Bodyguard Condition** (Keenan (1976)):

when a non-subject is fronted in a cleft, it can optionally be accompanied by
the grammatical subject

I will continue to call the first element (the adjunct) the pivot and refer to the second (the subject) as the bodyguard. Interestingly, the bodyguard construction is not available in the other Austronesian languages that I am aware of.

The question immediately arises as to whether the two fronted

³⁰ Unlike Hungarian, however, Malagasy pivots are predicates, not arguments, as discussed above.

³¹ Here I restrict the bodyguard condition to clefts. See section 2.5 for discussion.

elements are both in a focus position (either together in the same one or in two separate focus projections). Following the discussion in section 2.5, I will argue that in fact only the first element (the adjunct) is a pivot in the usual sense. The second element (the subject) is in a lower topic projection. The proposed structure is given in (65).

(65)

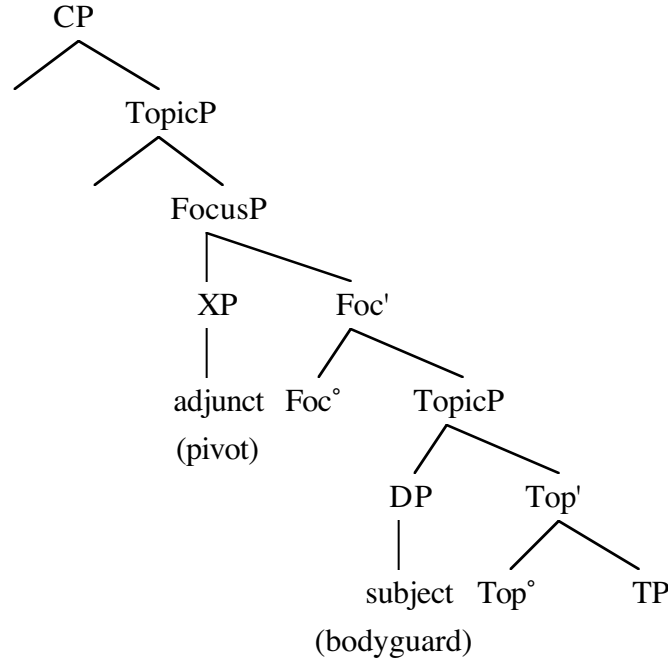

I have argued elsewhere that in the bodyguard construction, the adjunct adjoins to the subject and both front as a unit (Paul (1998)). Here, I reject that analysis (see section 5.2) and argue that the structure in (65) more accurately captures interpretational and structural peculiarities of the bodyguard construction. For the moment, I set aside the question of whether the bodyguard is base generated or moved into [Spec, TopicP]. I will address this issue in section 5.5.

In the following sections, I discuss other possible analyses of the bodyguard construction, namely coordination, amalgamation and multiple specifiers. I will show that none of these alternatives adequately accounts for the data. In the discussion, I will present arguments for treating the bodyguard as a topic.

Before turning to these alternate analyses, however, I will point out some potentially problematic aspects of the bodyguard construction.

First, it is often argued that a sentence can have only a single focus (Rizzi (1997); Zubizarreta (1998)). This is for interpretational reasons. Let us reconsider the division of a sentence into pivot and presuppositional clause.

(66) [pivot [presuppositional clause]]

The presuppositional clause is restricted to given information. It therefore cannot contain a focussed element (new information). We then conclude that if the bodyguard construction expresses multiple focus, it could not involve multiple focus projections. Instead, along the lines of multiple *wh*-questions, the two elements would have to form a unit at some level (“absorption”). Second, recall that I have argued that in a cleft, the pivot is a predicate. If the bodyguard were truly an example of a multiple cleft, this would require there being more than one predicate. Clearly, this is not possible in a non conjoined clause. Thus we have indirect evidence for treating the bodyguard as something other than a second pivot. This point will be important in the following sections.

5.1 Coordination

In the proposed tree in (65), the two parts of a bodyguard construction do not form a constituent. That is, the adjunct and the subject are in separate projections. Another possible analysis of the bodyguard construction would treat this as some form of covert coordination in the focus position. The bodyguard construction does not, however, pattern with overtly coordinated pivots. With overt coordination, for example, two adjuncts are possible in the pivot (67a). Moreover, it is not possible to overtly conjoin an adjunct and the subject (67b).

- (67) a. Omaly ary tany an-tsena no nivity vary Rasoa.
 yesterday and pst.there at-market foc pst.AT.buy rice Rasoa
 ‘It was yesterday and at the market that Rasoa bought rice.’
- b. * Omaly ary Rasoa no nanoroka an-dRakoto.
 Yesterday and Rasoa foc pst.AT.kiss acc-Rakoto

Precisely the reverse is true for the bodyguard construction: two adjuncts are ungrammatical and an adjunct-subject combination is grammatical.³²

- (68) a. * Omaly tany an-tsena no nivity vary Rasoa.
 yesterday pst.there at-market foc pst.AT.buy rice Rasoa
 ‘It was yesterday at the market that Rasoa bought rice.’
- b. Omaly Rasoa no nanoroka an-dRakoto.
 Yesterday Rasoa foc pst.AT.kiss acc-Rakoto
 ‘It was yesterday that Rasoa kissed Rakoto.’

Thus (68b) and other instances of the bodyguard construction are not some form of covert coordination.

5.2 Amalgamation

In Paul (1998), I argued that the Malagasy bodyguard construction is equivalent to the amalgamation of *wh*-elements in Japanese. To see the parallels, I briefly review the Japanese data. I will then show, however, that this analysis is untenable.

Saito (1994) proposes that an adjunct *wh*-element can adjoin to an argument *wh*-element. He points out the following contrast.

- (69) a. John-ga nani-o naze katta-no?
 John-nom what-acc why bought-Q
 ‘Why did John buy what?’
- b. * John-ga naze nani-o katta-no?
 John-nom why what-acc bought-Q
- c. Dare-ga naze nani-o katta-no?
 who-nom why what-acc bought-Q
 ‘Why did who buy what?’

(69a), where the argument *nani-o* ‘what’ precedes the adjunct *naze* ‘why’, is

³² (68a) improves with a distinct pause between the two adjuncts, indicating perhaps that the first adjunct is in some clause-adjoined position. The bodyguard construction does not require this marked pause between the pivot and the bodyguard.

grammatical. (69b) shows that the reverse order is ungrammatical. Interestingly, adding another higher argument *wh*, as in (69c), improves the grammaticality of (69b). This is referred to as the “additional-*wh* effect”. Simplifying Saito’s account somewhat, the adjunct *wh* adjoins to a higher argument *wh* at LF. From this position, it can license its trace and escape an ECP violation. Adjunction obtains in (69a,c) but not in (69b), where the adjunct c-commands the argument, resulting in the ungrammaticality of (69b).

Pursuing this analysis, Tanaka (1998) claims that *wh*-elements can amalgamate and then move as a constituent in overt syntax. He shows that the ungrammatical long-distance scrambling of a *wh*-adjunct in (70a) improves when an argument *wh* scrambles along with it, as in (70b).

- (70) a. * Naze_i John-ga [Bill-ga nani-o t_i naosita-kadooka]
 why John-nom Bill-nom what-acc fixed-whether
 siritagatteiru-no?
 want-to-know Q
- b. Nani-o_i naze_j John-ga [Bill-ga t_i t_j naosita-kadooka]
 what-acc why John-nom Bill-nom fixed-whether
 siritagatteiru-no?
 want-to-know Q
 ‘What does Bill want to know why Bill fixed?’

Together with the data in (69), the examples in (70) illustrate a certain dependency between an adjunct *wh* and an argument *wh*. Moreover, the amalgamated *wh*-elements can surface in the focus position of a cleft construction.

- (71) John-ga Mary-ni ageta-no-wa nani-o naze datta-no?
 John-nom Mary-dat gave-nm-top what-acc why cop-pst-Q
 (lit.) ‘It was what why that John gave to Mary?’

Tanaka argues that (70) and (71) both indicate that amalgamation can occur in the syntax as well as at LF.

Let us examine the important aspects of the above analysis and

compare them with the Malagasy facts. Crucially, in Japanese an adjunct *wh* adjoins to an argument *wh* for licensing. In other words, only an argument can “host” an adjunct. Recall that the bodyguard construction also involves an adjunct and an argument (the subject). Moreover, as seen in (70) and (71), amalgamation in Japanese allows the two *wh*-elements to move together and appear in a cleft. Recall that the bodyguard construction arises in clefts. Due to these parallels between the Japanese amalgamation and the Malagasy bodyguard, it is possible that in Malagasy, the adjunct adjoins to the subject and both front as a unit (as in the tree in (72), proposed in Paul (1998)).

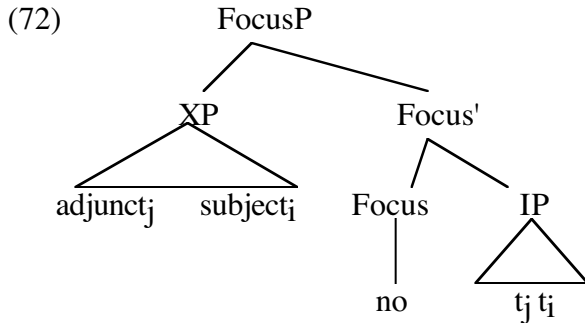

There are a number of differences, however, between the bodyguard construction in Malagasy and the Japanese amalgamation.

First, only *wh*-phrases may host other *wh*-phrases in Japanese. We have seen that the bodyguard construction is easily possible with non-*wh* elements. Moreover, it is possible in Malagasy to have a combination of + and -*wh* words in the bodyguard construction. (Note, however, that (73b) is only acceptable for those speakers who allow a *wh* bodyguard (see sections 5.3.3 and 5.6 for further discussion). The % in (73b) indicates that the example is subject to dialectal variation.)

- (73) a. Taiza i Bakoly no nanasa lamba?
 pst.where Bakoly foc pst.AT.wash cloth
 ‘Where did Bakoly wash clothes?’
- b. % Tamin’io loko io iza no nandoko trano?
 pst.P.gen.this paint this who foc pst.AT.paint house
 ‘Who painted houses with this paint?’

Thus Japanese amalgamation is both more restricted than Malagasy bodyguard (limited to *wh*-phrases) and less restricted (having a *wh*-phrase as a bodyguard is in fact highly marked in Malagasy). These differences could stem, however, from independent properties of the two languages. In other words, amalgamation could be used by different languages in different ways. I turn to data which are more problematic for the amalgamation approach.

In the tree in (72), the two fronted elements form a constituent. Initial evidence against the constituency of the pivot and bodyguard comes from clausal coordination.

- (74) Omaly Rasoa no nivarotra hena ary Rakoto no nividy mofo.
 yesterday Rasoa foc pst.AT.sell meat and Rakoto foc pst.AT.buy bread
 ‘It was yesterday that Rasoa sold meat and Rakoto bought bread.’

In (74), the adjunct *omaly* ‘yesterday’ is interpreted as modifying both clauses. In other words, it appears that we have conjunction of a constituent that includes the subject but excludes the adjunct, perhaps TopicP.

- (75) [_{FocP} omaly [[_{TopP} Rasoa no ...] ary [_{TopP} Rakoto no ...]]
 yesterday Rasoa foc and Rakoto foc

(74) is problematic under an account where both the adjunct and the subject appear amalgamated in a single position.

Furthermore, the pivot and the bodyguard can be separated by the question particle *ve* and the parenthetical *hono* ‘so they say’.

- (76) a. Omaly **ve** Rasoa no nanapaka bozaka?
 yesterday Q Rasoa foc pst.AT.cut grass
 ‘Was it yesterday that Rasoa cut grass?’
- b. Omaly **hono** Rasoa no nanapaka bozaka.
 yesterday so-they-say Rasoa foc pst.AT.cut grass
 ‘It was yesterday, so they say, that Rasoa cut grass’

- b. Ko koga vidi? Serbo-Croatian
who whom sees
'Who sees whom?'

Rudin argues that in Bulgarian, but not in Serbo-Croatian, all the fronted *wh*-words form a constituent.

To support this distinction, Rudin discusses three main differences between Bulgarian and Serbo-Croatian: constituency, ordering and island effects. I will concentrate on the first two. She shows that in Bulgarian, nothing can separate the *wh*-words, as shown in (78a). In Serbo-Croatian, on the other hand, clitics and parentheticals appear between the first *wh*-word and the others, as illustrated in (78b).

- (78) a. * Koj ti e kakvo kazal? Bulgarian
who you is what told
'Who told you what?'
- b. Ko mu je sta dao? Serbo-Croatian
who him is what given
'Who gave him what?'

Rudin also shows that Bulgarian, but not Serbo-Croatian, imposes linear ordering constraints on the fronted *wh*-words. She gives the following examples.

- (79) a. Koj kogo e vidjal? Bulgarian
who whom is seen
'Who saw whom?'
- b. * Kogo koj e vidjal?
whom who is seen

The contrast between (79a) and (79b) shows that the nominative *wh* must precede the accusative *wh*-element in Bulgarian. Serbo-Croatian, however, allows either order.

- (80) a. Ko je koga vidio? Serbo-Croatian
 who is whom seen
 ‘Who saw whom?’
- b. Koga je ko vidio?
 whom is who seen

Recently, Richards (1997) has accounted for these differences by slightly modifying Rudin’s analysis. He argues that in Bulgarian, all the *wh*-elements are in distinct [Spec, CP] positions (the “multiple spec” analysis). For Serbo-Croatian, he suggests that only the first raises to [Spec, CP], the rest are adjoined to IP via scrambling.³⁴

Let us now return to the Malagasy bodyguard construction and compare it to multiple fronting in Slavic. One distinction between the Malagasy multiple fronting and Slavic is that Malagasy restricts fronting to two elements. Slavic languages, such as Bulgarian, do not have this limit as shown by (81).

- (81) Koj kakvo no kogo e dal? Bulgarian
 who what to whom has given
 ‘Who gave what to whom?’

Setting this difference aside for the moment, is Malagasy more like Bulgarian or Serbo-Croatian? Recall that in the bodyguard construction, the *wh*-words are strictly ordered: adjunct>subject. This is like Bulgarian, in that the linear sequence is fixed, but in the reverse order (see (79)). Additionally, Malagasy is not a scrambling language, unlike Serbo-Croatian. Assuming for the moment Malagasy to be a Bulgarian-type fronting language, but with funny word order (after all, it is a VOS language!), we would place both elements in the bodyguard construction in multiple specifiers of FocusP, as in the tree below.^{35,36}

³⁴ In several recent papers, Boskovic has criticized the Rudin/Richards analysis of the difference between Bulgarian and Serbo-Croatian (Boskovic (1997; 1998)). Although the two papers offer different analyses, both posit a single head that attracts all the *wh*-elements. As we will see immediately, this is not a possible analysis for Malagasy multiple fronting.

³⁵ Alternatively, Rudin’s analysis would adjoin the adjunct to the subject in [Spec, CP]. This gives rise to a structure similar to the amalgamation discussed above and hence suffers from the

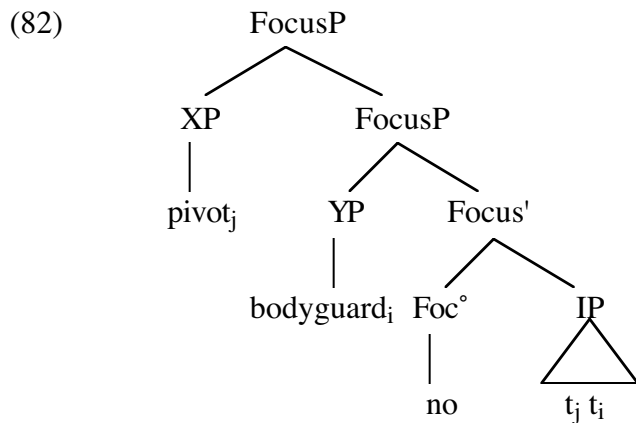

I will argue, however, that this is not the correct structure for the bodyguard construction, drawing on data from interpretation. In particular, I will show that the bodyguard does not receive a focus interpretation, which is unexpected if the bodyguard is [Spec, FocusP]. I then show that on the contrary, the bodyguard has topic-like properties.

5.3.2 *Bodyguard* ≠ *focus*

In this section, I argue that in fact only the pivot and not the bodyguard is in a focus projection, drawing on differences in interpretation between the pivot and the bodyguard. In section 4, we saw that the cleft construction is associated with a particular focus interpretation. If the bodyguard condition involves movement of both elements into a focus projection (as in the multiple specifier analysis), we would expect both to receive a focus reading. I will show that this is not the case.³⁷

Recall from the discussion of single clefts that the pivot is interpreted as exhaustive (seen in examples (59) and (60) in section 4). Hence the presupposition of exhaustivity can be denied. Let us turn now to the example in (83a), which has a bodyguard construction. The data indicate that in (83a), *omaly* ‘yesterday’ is focussed and therefore the presupposition of exhaustivity behind this focus can be negated, as in (83b). On the other hand, the bodyguard, *Raso*, is not focussed and

same drawbacks. Note also that the tree in (84) is not possible if focussed elements are predicates, as we have seen earlier.

³⁶ Malagasy differs from Bulgarian in allowing elements to appear between the pivot and the bodyguard. Thus one could conclude that Malagasy is not like Bulgarian nor like Serbo-Croatian, which in fact I believe to be the case.

³⁷ In fact, the data in the following subsections also point away from the coordination and amalgamation analyses, which also place both the pivot and the bodyguard in the focus projection.

therefore cannot be negated, hence both (83c) and (83d) are inappropriate follow-ups to (83a).

- (83) a. A: *Omary Rasoa no nijinja vary.*
 yesterday Rasoa foc pst.AT.harvest rice
 ‘It was yesterday that Rasoa harvested rice.’
- b. B1: *Tsia, afak’omaly izy no nijinja vary.*
 no free’yesterday 3(nom) foc pst.AT.harvest rice
 ‘No, it was the day before yesterday that she harvested rice.’
- c. # B2: *Tsia, afak’omaly Rakoto no nijinja vary.*
 no free’yesterday Rakoto foc pst.AT.harvest rice
 ‘No, it was the day before yesterday that Rakoto harvested rice.’
- c. # B3: *Tsia, omaly Rakoto no nijinja vary.*
 no yesterday Rakoto foc pst.AT.harvest rice
 ‘No, it was yesterday that Rakoto harvested rice.’

Thus we see that the bodyguard has a semantic force that differs from pivots in standard clefts.

Similar results obtain for negation. Recall that the pivot in a cleft can take negation, cited earlier as evidence in favour of the predicate-like nature of the pivot. Interestingly, the bodyguard cannot be negated. This difference between the pivot and the bodyguard is illustrated in (84).

- (84) a. *Tsy omaly Rasoa no nandeha fiara.*
 neg yesterday Rasoa foc pst.AT.go car
 ‘It wasn’t yesterday that Rasoa went by car.’
- b. * *Omary tsy Rasoa no nandeha fiara.*
 yesterday neg Rasoa foc pst.AT.go car
 ‘It was yesterday that it wasn’t Rasoa who went by car.’

Note that in (84a), negation takes scope over *omaly* ‘yesterday’ and not *Rasoa*, which remains part of the presupposition.

Consider next negative conjuncts. For one of my speakers, negative conjuncts are possible in all positions, subject, object, predicate. For another, however, the examples in (85) are all ungrammatical. I therefore mark (85) with (*) to indicate this variation in judgement. It is the restricted use of negative conjuncts by this second speaker that is crucial to the following discussion.

- (85) a. (*) Nanasa lamba Ranaivo fa tsy Rabe.
 pst.AT.wash cloth Ranaivo C neg Rabe
 ‘Ranaivo and not Rabe washed clothes.’
- b. (*) Nanasa lamba fa tsy lovia Ranaivo.
 pst.AT.wash cloth C neg dish Ranaivo
 ‘Ranaivo washed clothes and not dishes.’
- c. (*) Nanasa fa tsy nanjaitra lamba Ranaivo.
 pst.AT.wash C neg pst.AT.sew cloth Ranaivo
 ‘Ranaivo washed and not sewed clothes.’

Importantly, for the second speaker the only possible position for a negative conjunct is after the pivot, as illustrated in (86a,b). In (86b), the negative conjunct appears between the pivot and the bodyguard.

- (86) a. Omaly fa tsy androany no nandoko trano i Bakoly.
 yesterday C neg today foc pst.AT.paint house Bakoly
 ‘It was yesterday and not today that Bakoly painted a house.’
- b. Omaly fa tsy androany Bakoly no nandoko trano.
 yesterday C neg today Bakoly foc pst.AT.paint house
 ‘It was yesterday and not today that Bakoly painted a house.’

Thus for the second speaker, a negative conjunct is only available after a focussed element. For this speaker, as shown in (87) the bodyguard itself cannot take a negative conjunct, unlike the pivot in (86).³⁸

³⁸ (87) is grammatical, however, for the speaker who has freer placement of the conjunct. What is crucial is the contrast between (86) and (87) for the other speaker.

- (87) (*) Omaly i Bakoly fa tsy Rabe no nandoko trano.
yesterday Bakoly C neg Rabe foc pst.AT.paint house
'It was yesterday that Bakoly and not Rabe painted the house.'

The ungrammaticality of (87) for this speaker indicates that the bodyguard is not focussed.

Summing up, in this section I have argued that the properties of the true pivot are different from those of the bodyguard. The impossibility of negation indicates that the bodyguard is not a predicate. The impossibility of a negative conjunct (for one speaker) is likely tied to the lack of an exhaustive interpretation for the bodyguard, mentioned above in the discussion of example (83). For this speaker, negative conjuncts are only possible when the first conjunct is interpreted as exhaustive. A range of data indicate that the bodyguard does not receive a focus interpretation and therefore does not appear in [Spec, FocusP]. These results are clearly incompatible with the multiple specifier analysis of multiple fronting. I next look more closely at the bodyguard itself, for further evidence against the multiple spec approach.

5.3.3 *Bodyguard = topic*

In the structure proposed, the bodyguard appears in a topic position. I now support this analysis by showing that the bodyguard has topic properties. It is used for presupposed information.³⁹ This contrasts with the pivot, which is for non-presupposed material. I will draw on data from definiteness restrictions and question-answer pairs to support this distinction. Due to the sharp differences between the pivot and the bodyguard, I conclude that the multiple specifier analysis is not appropriate for Malagasy multiple fronting. In other words, Malagasy multiple fronting should be treated differently from Slavic. Additionally, this section provides evidence in favour of the proposed analysis of the left periphery, given in section 2.

As an initial observation, recall from section 2.4 that indefinite DPs can appear in the focus position. The bodyguard, however, must be definite, as shown by the contrast between (88b) and (88c).

³⁹ Alternatively, the bodyguard could be part of the presuppositional clause. See section 5.5 for discussion of this possibility.

- (88) a. Zazavavy no nilalao baolina tany an-tokotany.
 girl foc pst.AT.play ball pst.there at-yard
 ‘It was girls who were playing in the yard.’
- b. * Tany an-tokotany zazavavy no nilalao baolina.
 pst.there at-yard girl foc pst.AT.play ball
- c. Tany an-tokotany ny zazavavy no nilalao baolina.
 pst.there at-yard det girl foc pst.AT.play ball
 ‘It was in the yard that the girls were playing ball.’

Since topics refer to presupposed information, they must be definite (or specific).⁴⁰ This definiteness restriction on the bodyguard points toward it being a topic position. Further, the contrast between (88a) and (88c) illustrates an important difference between the pivot and the bodyguard, suggesting that the two are not both in a focus projection.

As a further distinction, consider the distribution of pronouns. The bodyguard is fully compatible with pronouns that refer to previously mentioned DPs. Thus one possible answer to (89a) is given in (89b).

- (89) a. Q: Taiza no nandeha fiara i Soa?
 pst.where foc pst.AT.go car Soa
 ‘Where did Soa go by car?’
- b. A: Tany Antananarivo izy no nandeha fiara.
 pst.there Antananarivo 3(nom) foc pst.AT.go car
 ‘It’s to Tana that she went by car.’

In (89a), *i Soa* is part of the presuppositional clause. Since the pronoun *izy* in the bodyguard position can refer to this presupposed DP, the bodyguard cannot be a focus position. In general, the true pivot cannot refer to presupposed information, showing that even in a bodyguard construction it retains its focus interpretation, which is restricted to new

⁴⁰ Although topics are presupposed, all presupposed information is not necessarily a topic. For example, objects in the presuppositional clause may be nonspecific, as illustrated in (88a).

information. Hence (90b), although fully grammatical, is not an appropriate answer to (90a).

- (90) a. Q: Nividy boky taiza omaly i Soa?
 pst.AT.buy book pst.where yesterday Soa
 ‘Where did Soa buy books yesterday?’
- b. # A: Omaly izy no nividy boky tany an-tsena.
 yesterday 3(nom) foc pst.AT.buy book pst.there at-market
 ‘It was yesterday that she bought books at market.’

The unacceptability of (90b) as an answer to (90a) is due to the presence of *omaly* ‘yesterday’ in the pivot position. *omaly* ‘yesterday’ is part of the presuppositional clause in (90a) and hence is incompatible with the focus associated with the pivot. Note that the unacceptability of (90b) does not lie with the answer to the *wh*-question being in-situ. This is possible, even in a clefted clause.⁴¹

- (91) a. Q: I Soa no nandeha fiara taiza?
 Soa foc pst.AT.go car pst.where
 ‘Where did Soa go by car?’
- b. A: I Soa no nandeha fiara tany Ambositra.
 Soa foc pst.AT.go car pst.there Ambositra
 ‘Soa went to Ambositra by car.’

Thus the problem with (90b) is due to presupposed information appearing in the pivot position.

Consider now the use of the bodyguard construction in question-answer pairs. I will first provide some background on question-answer pairs in Malagasy. In general, if the question has the form of a cleft, a cleft answer is required. For in-situ questions such as (92a), either a cleft (92c) or an in-situ (92b) answer is possible, the former being slightly marked due to the added focus interpretation.

⁴¹ At this point, it is not clear to me how a *wh*-in situ is interpreted in a presuppositional clause (as in (91a)). I leave this for future work on *wh*-in situ.

- (92) a. Q: Nanasa lamba tamin'inona Rakoto?
 pst.AT.wash cloth pst.P.gen.what Rakoto
 'What did Rakoto wash clothes with?'
- b. A1: Nanasa lamba tamin'ity savony ity Rakoto.
 pst.AT.wash cloth pst.P.gen.this soap this Rakoto
 'Rakoto washed clothes with this soap.'
- c. A2: Tamin'ity savony ity no nanasa lamba Rakoto.
 pst.P.gen.this soap this foc pst.AT.wash cloth Rakoto
 'It's with this soap that Rakoto washed clothes.'

Importantly, either a cleft or a non-cleft answer is appropriate.

Let us now turn to multiple *wh*-questions. Bodyguard clauses are not appropriate answers to multiple *wh*-questions where one *wh*-element is in-situ.

- (93) a. Q: Iza no nanapaka bozaka oviana?
 who foc pst.AT.cut grass when
 'Who cut grass when?'
- b. # A1: Omaly Rasoa no nanapaka bozaka.
 yesterday Rasoa foc pst.AT.cut grass
 'It was yesterday that Rasoa cut grass.'
- c. A2: Rasoa no nanapaka bozaka omaly.
 Rasoa foc pst.AT.cut grass yesterday
 'It was Rasoa who cut grass yesterday.'

I suggest that (93b) is an inappropriate answer because the bodyguard position cannot be used for new information, *Rasoa* in this case.⁴² I link this limitation on the bodyguard to it being a topic.

⁴² Again, the problem with (93b) is not due to the clefting of *omaly* 'yesterday'. (92c) shows that the answer to an in-situ question can be realized as a cleft. Note also that we cannot reverse the order of *omaly* and *Rasoa*, due to the ordering constraints in the bodyguard construction.

I will discuss *wh* bodyguard in section 5.6. For the moment, however, note that if the bodyguard is indeed a topic, it should be incompatible with *wh*-elements, which are usually associated with focus (both interpretationally and positionally). This is in general true: (94a) is ungrammatical for some of the Malagasy speakers I have consulted. For one of my consultants, however, the bodyguard can be a *wh*-element, with a restricted interpretation. She requires that the bodyguard *wh*-word be D-linked, in the sense of Pesetsky (1987). In other words, there must be a context-specified set of people, known to both the speaker and hearer, that restricts the range of possible answers. For this speaker, a multiple *wh*-question can take a bodyguard construction as the answer if the question itself has the form of a bodyguard construction. (94b) is therefore an appropriate answer to (94a). (Recall that % in (94a) indicates that it is subject to dialectal variation.)

- (94) a. % Q: Oviana iza no nanapaka bozaka?
 when who foc pst.AT.cut grass
 ‘When did who cut grass?’
- b. A: Omaly Rasoa no nanapaka bozaka.
 yesterday Rasoa foc pst.AT.cut grass
 ‘It was yesterday that Rasoa cut grass.’

Due to D-linking, the referent of *iza* ‘who’ in (94a) is restricted: the set of people under consideration is known to the speaker and hearer. A more literal translation of (94a) would be ‘When did which of them cut grass?’, where ‘them’ refers to the set of possible people. The answer (*Rasoa*) is a possible bodyguard since it is not completely new information. This use of the bodyguard construction will be discussed again in section 5.6.

A range of data shows that in a bodyguard construction, only the first element (the true pivot) is focussed. The second element has topic properties. I therefore reject the multiple specifier analysis of multiple fronting. Despite initial similarities, Malagasy bodyguard has very different properties from Slavic *wh*-fronting. Thus any analysis of the latter will not apply to the former.

Note that this conclusion then suggests that *no* is not a focus marker

per se, since the elements that precede it are not necessarily uniformly focussed elements. Thus we have indirect evidence in favour of the relative clause structure for clefts given in (33b) in section 3.2 and against treating *no* as the head of a focus projection, as in (27) in section 3.1.

5.4 Where are we?

I have argued against three possible analyses of the bodyguard. In particular, I have shown that the pivot and the bodyguard do not form a constituent nor do they share focus properties. I therefore concluded that they are in distinct positions, [Spec, FocusP] for the pivot and [Spec, TopicP] for the bodyguard. (95) provides the basic structure for a (matrix) bodyguard clause, such as (94b). (This FocusP may also appear embedded under TopicP or other complementizer projections.)

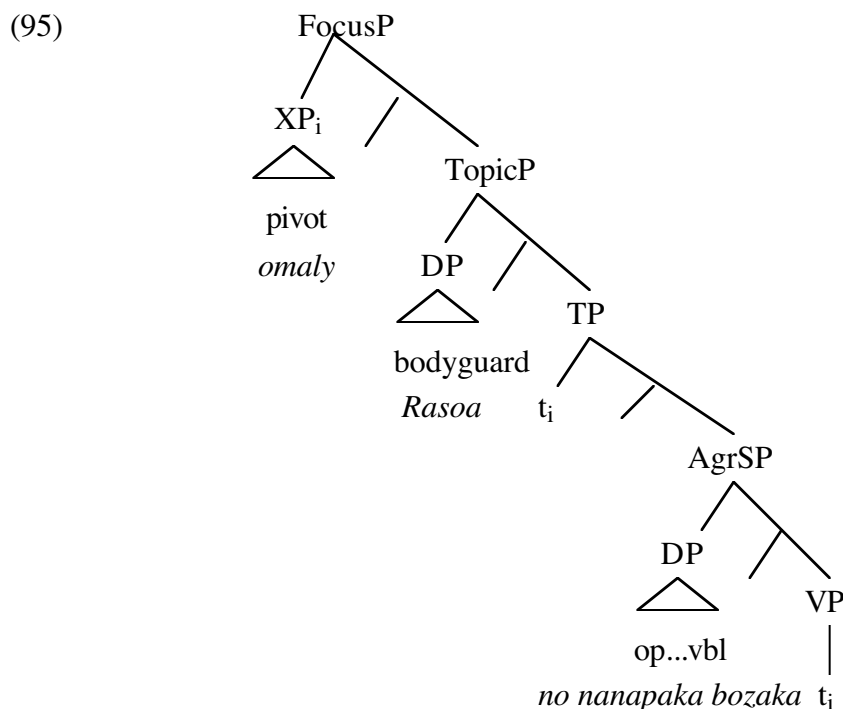

In the discussion in section 5.6 below of *wh*-fronting, another instance of the cleft construction, we will see more data that confirm the difference in interpretation between the pivot and the bodyguard. I now look more closely at how movement of the bodyguard obtains.

5.5 Speculations

In the preceding sections, I have argued for a topic position below focus: the bodyguard. There remain some unexplained problems with this proposal. If we consider the tree in (95), the bodyguard apparently moves out of the headless relative clause to the topic position. This movement is highly problematic; given standard assumptions, the bodyguard movement illustrated in (95) violates the complex DP constraint. Second, this topic position is limited to subjects. We saw earlier that as well as subjects, adjuncts can be topicalized, hence this restriction is somewhat surprising. Third, the bodyguard position is only available in cleft constructions. Why would a topic projection be dependent on a higher focus projection? Finally, as pointed out in footnote 4, Rizzi's low topic position is highly marked in Italian and is not available in many languages (e.g. Spanish, Maori, Tagalog, Mayan languages). In this section, I speculate on how to resolve these difficulties and consider three alternate analyses to direct movement.

As a first solution, it is possible to claim that the bodyguard is not moved to the topic position, but is base-generated there. An empty operator binds a null resumptive *pro* in the headless relative. A similar account for Italian topicalization is proposed by Rizzi (1997). An anaphoric operator (in the specifier of a projection below the TopicP and above TP, perhaps FinP) is coindexed with the bodyguard topic and binds a null constant. This operator does not assign a range to its bindee, instead it links its antecedent (the topic) to the bindee (the empty category). In other words, the relation between the operator and the empty category is not one of quantification. Moreover, null constants are only DPs and not other categories, as argued by Cinque (1990); Rizzi (1997). Although this may account for the restriction of the bodyguard to (DP) subjects, the movement of the operator from the headless relative to [Spec, FinP] is still problematic.

The second solution is to drop the headless relative analysis of clefts. Without the complex DP, topicalization can proceed as in Italian, as outlined above. I believe, however, that the arguments for the headless relative analysis of clefts are compelling. The sole advantage would be a simple analysis of the bodyguard construction.

As a final possibility, the bodyguard could in fact be *within* the headless

relative: a subject in [Spec, DP].

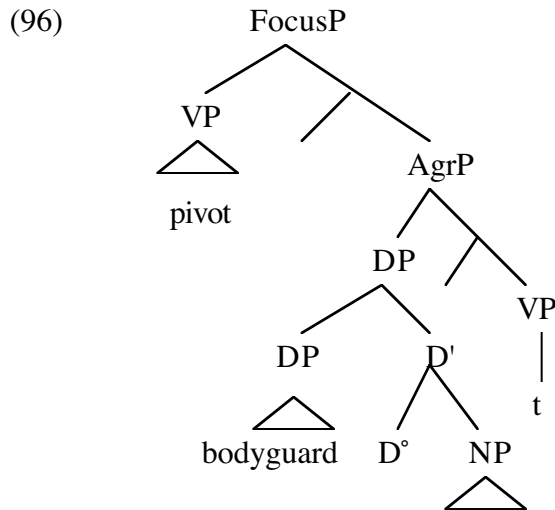

Under this approach, the bodyguard is a kind of preverbal subject that is only licensed in headless relative clauses (perhaps by the event nominal).

This analysis has some advantages. It accounts for the restriction of bodyguards to subjects, the topic properties of bodyguards and the markedness of *wh*-bodyguards. Consider first the following example. As stated earlier, the headless relative in these instances is interpreted as an event nominal.

- (97) Omaly Rasoa no nanapaka bozaka.
 yesterday Rasoa foc pst.AT.cut grass
 'It was yesterday that Rasoa cut grass.'

Under the analysis in (96), the meaning of (97) is in fact 'Rasoa's cutting of grass was yesterday', a promising result. The restriction to subjects falls out from the analysis. Since by hypothesis, the bodyguard is a preverbal subject, adjuncts will never be in this position. The topic properties of bodyguards discussed in 5.3.3 follow from the fact that subjects in Malagasy have topic-like properties, as noted by many researchers. Finally, consider the marginality of *wh* bodyguards. Although Malagasy has *wh*-in situ, *wh*-elements can never surface in the subject position.

- (98) * Nanapaka bozaka iza?
 pst.AT.cut grass who
 ‘Who cut grass?’

If bodyguards are subjects, it is not surprising that *wh*-elements are in general banned from the bodyguard position. Treating the bodyguard as a preverbal subject in headless relatives is clearly a promising analysis. Nevertheless, I leave it for further research to determine whether this is the correct approach.

Before turning to *wh*-bodyguards, I would like to point out that the speculative nature of this section does not call into question the conclusion that the bodyguard patterns with topics and not with focussed elements. The only uncertainty is the precise position that the bodyguard occupies.

5.6 *Wh*-bodyguard

As mentioned above, the bodyguard construction is not available for *wh*-elements for most speakers of Malagasy.⁴³ I explained this restriction by invoking an incompatibility between *wh*-elements and topics. The consultant who accepts *wh*-bodyguard is very consistent in her judgements, however. I will therefore examine this construction in her grammar. The data will provide further support for the proposed analysis of the bodyguard construction. In particular, I will look at ordering and interpretational restrictions.

5.6.1 Order

Parallel to the standard bodyguard construction, multiple *wh*-clefts have a fixed word order: adjunct>subject. Placing the subject before the adjunct

⁴³ I have recently discovered that the consultant who rejects bodyguard *wh* in matrix clauses, accepts the same construction in embedded clauses.

- (i) Manantena Rasoa fa taiza iza no nivity ilay boky?
 AT.hope Rasoa C pst.where who foc pst.AT.buy def book
 ‘Who does Rasoa hope bought the book where?’

(i) is a matrix question, with both *wh*-elements taking wide scope. I must set aside this puzzle for two reasons. First, in this chapter, I have mainly been concerned with mono-clausal examples. Embedded clauses involve further complications. Second, I have not had the time to properly investigate the differences between matrix and embedded *wh*-bodyguard constructions. Nevertheless, initial field work has shown that the properties discussed in this section, namely word order and D-linking, also apply to embedded *wh*bodyguard.

Interestingly, Rizzi (1997: fn 18) points out that some speakers of Italian allow for both a *wh*-phrase and a focussed element in embedded contexts (in clear contrast with matrix clauses). He speculates that *wh*-elements in embedded clauses appear in a position different from matrix *wh* (i.e. not in [Spec, FocusP]).

results in ungrammaticality. The examples in (99) illustrate this ordering restriction.

- (99) a. % Oviana iza no lasa nody?
 when who foc left pst.AT.go-home
 ‘Who went home when?’
- b. * Iza oviana no lasa nody?
 who when foc left pst.AT.go-home

As shown in section 5.1, it is not possible to account for multiple fronting by proposing some form of covert coordination. When an overt conjunction is added, as in (100), the order of elements is reversed: subjects precede adjuncts. (100) thus contrasts with the bodyguard construction in (99a).⁴⁴

- (100) Iza ary oviana no lasa nody?
 who and when foc left pst.AT.go-home
 ‘Who went home and when?’

Impossible, moreover, is an adjunct bodyguard, even in cases where the adjunct has been promoted to subject with CT.

- (101) * Taiza manao ahoana no nandokoan-dRabe ireto trano ireto?
 pst.where AT.do how foc pst.CT.paint.gen.Rabe these house these
 ‘Where and how did Rabe paint these houses?’

Finally, note that a maximum of two *wh*-elements front.

⁴⁴ From the perspective of English, (100) is very odd. As noted by Browne (1972), in English, only *wh*-adjuncts may be conjoined, not arguments.

(i) a. When and where did you see them?
 b. * Who and with what broke the glass?

The astute reader may recall that this type of conjunction is impossible for non-*wh* clefts; (100) thus contrasts with (ii).

(ii) * Rasoa ary omaly no lasa nody.
 Rasoa and yesterday foc left pst.AT.go-home

I have no explanation for the difference in grammaticality between (100) and (ii).

(102) * Nahoana taiza iza no nivity io boky io?
 why pst.where who foc pst.AT.buy thisbook this

As shown by (103), the ungrammaticality of (102) is not due to some kind of parsing limitation: it is possible to have three *wh*-elements in a clause.

(103) % Nahoana iza no nivity io boky io taiza?
 why who foc pst.AT.buythis book this pst.where
 ‘Why did who buy this book where?’

It thus appears that only two elements may be fronted.

What accounts for the word order and “max two” effect in bodyguard constructions? Consider first the adjunct>subject ordering. In the proposed analysis, the first element (the pivot) is focussed and the second (the bodyguard) is a special kind of topic. This is also true in *wh*-bodyguard examples: only the first *wh*-element is truly in a focus position. The second is in the topic position. We have seen that this topic position is limited to subjects (either by the null constant analysis or by treating it as a pre-verbal subject). Therefore an adjunct will never be a bodyguard.⁴⁵ In principle, either an adjunct or the subject can be in the pivot position, but because the bodyguard is the subject and there is only one subject, the pivot is limited to adjuncts in the bodyguard construction. Moreover, since FocusP dominates TopicP, the word order is adjunct>subject. Finally, as neither the focus position nor this special topic can iterate, examples like (102) cannot be generated. The proposed analysis of the bodyguard construction as focus plus topic provides a simple account for the basic properties of this construction.

5.6.2 *D-linking*

In the following, I illustrate some interesting properties of *wh* bodyguard constructions which will provide additional evidence for the topic-like status of the bodyguard. Keenan (1976) notes that the best “bodyguards” are active agents. Nevertheless, the following, where the bodyguard is a theme subject, is an acceptable sentence.

⁴⁵ An adjunct that has been promoted to subject with CT, as in (101), is also ruled out from the bodyguard position. This is likely due to the same constraint that prohibits non-referential DPs from the subject position (see chapter 3).

- (104) % Nahoana iza no norohan-dRasoam?
 why who foc pst.TT.kiss.gen.Rasoam
 ‘Why was who kissed by Rasoam?’

In contrast to (104), an inanimate bodyguard is ungrammatical unless preceded by the determiner *ilay*.

- (105) a. * Taiza inona no novidin-dRasoam?
 pst.where what foc pst.TT.buy.gen.Rasoam
 ‘Where did Rasoam buy what?’
- b. % Taiza ilay inona no novidin-dRasoam?
 pst.where def what foc pst.TT.buy.gen.Rasoam
 ‘Where did Rasoam buy which of the things?’

Recall that I suggested that in order to overcome the incompatibility between topic and *wh*, a *wh*-bodyguard must be D-linked. Animates (*iza* ‘who’) are treated as D-linked in Malagasy, but inanimates (*inona* ‘what’) require a determiner.⁴⁶ Thus the topic status of the bodyguard position restricts the elements that can surface there.⁴⁷

Summing up, a certain dialect of Malagasy allows the multiple fronting of *wh*-elements. I have shown that this multiple fronting can be subsumed under the analysis given in section 5.4 for apparent multiple clefts. In other words, the first element (the pivot) is in a focus position, while the second (the bodyguard) is a topic. Since it is in a topic position, the bodyguard *wh* is obligatorily D-linked. A context-specified set of elements must be available to both speaker and hearer to restrict the

⁴⁶ Even in English, animate *wh*-elements are more “referential” than inanimates: they more easily admit a D-linked interpretation. One effect of this is the ability to escape from weak islands. The following data are from Szabolcsi and Zwarts (1992-1993).

- (i) a. Which man do you regret that I saw?
 b. ? Who do you regret that I saw?
 c. ?? What do you regret that I saw?

⁴⁷ All *wh*-elements, D-linked or other, are excluded from the *dia* topic position.

- (i) * Ny mpianatra iza dia nahamarina ny asa marika?
 det student who top pst.aha.true det work math
 ‘Which student did well on the math assignment?’

I do not have an explanation for this difference between *dia* topics and bodyguards. As mentioned earlier, topicalization in Malagasy awaits further research.

reference of the bodyguard *wh*-element. Thus although multiple *wh*-fronting is limited in distribution among Malagasy speakers, its properties support the proposed analysis of topic and focus.

6 Conclusion

This chapter has been devoted to the left periphery. I have argued that Malagasy has topic and focus positions in the CP layer of the clause. In other words, topicalized and focussed elements appear in pre-verbal positions, where topic > focus. These results provide evidence in support of Rizzi (1997)'s expanded CP. Furthermore, Rizzi's proposed structure neatly accounts for an unusual property of Malagasy: the bodyguard construction. I suggested that the bodyguard is in fact a topic. Like Italian, therefore, Malagasy apparently has an additional topic position below focus. I speculate on the nature of this topic position toward the end of the chapter.

I next looked more closely at the focus construction, which is formed by clefting. Under my analysis, a cleft has the structure of an equative clause, involving a headless relative in the subject position and a preposed predicate in the focus position. Interestingly, the predicate fronting proposed for clefts may be more general, perhaps accounting for VOS word order. I then showed that clefts in Malagasy are associated with a particular focus interpretation. This focus interpretation is linked to the position of the clefted element in [Spec, FocusP].

The last part of the chapter was devoted to apparent multiple clefts: the bodyguard construction. I provided evidence against three possible analyses of multiple clefts: coordination, amalgamation, and multiple specs. Although none of these approaches are valid for Malagasy, the discussion illustrated the importance of considering a range of data when looking at multiple fronting. Pursuing the ideas presented in the first part of the chapter, I argued that the bodyguard construction is best analyzed not as a multiple cleft, but as a combination of clefting and topicalization. Finally, I considered multiple *wh*-fronting and showed that the particular properties of this construction fall out from the analysis provided.

I consider the present chapter to be the first step in understanding the left periphery in Malagasy. The focus of this chapter was the cleft for two reasons: first, clefts were used as a test for structure in chapters 2 and 3;

second, a thorough analysis of the Malagasy complementizer system lies beyond the scope of a single chapter. For example, although I discuss topicalization, I do not provide an analysis. Clearly, this is an area that merits further work. Moreover, I have restricted my attention to monoclausal clefts, thereby ignoring a wide range of data, including long-distance dependencies and *wh*-questions in general. I also left unanswered questions about the bodyguard. Is it really a lower topic position or a preverbal subject within an event nominal? Why are embedded *wh* bodyguard constructions allowed while their matrix counterparts are generally ungrammatical? Finally, it would be important to compare the Malagasy facts with data from other Austronesian languages. Kroeger (1993) has analyzed several constructions in Tagalog where constituents appear pre-verbally: topicalization, clefting, adjunct fronting and *ay* inversion. To what extent the left periphery in other verb-initial languages is similar to Malagasy remains to be discovered.

Chapter 5: Conclusion

The present thesis is about Malagasy syntax. I repeat the obvious to remind the reader of the initial goal of this thesis: to grasp the “genius” of Malagasy. As should be equally obvious, I believe that the genius of this language lies in the voice system. Voice alternations are central to Malagasy grammar. Voice provides insight into syntactic structure. I argued in chapter 2 that different passive voices are indicative of different syntactic positions and domains. Voice can be more complex than traditional conceptions of passive. As shown by the data from circumstantial topic constructions, for example, voice is not limited to the promotion of arguments. Voice promotes elements to a syntactically prominent position, whence they are accessible to A-bar extraction. Voice morphemes can have different functions. Some target specific positions, some target particular domains, others are “elsewhere” in nature. In many ways, voice plays a salient and complex role in the syntax of Malagasy.

The discussion of passive in chapter 2 provided evidence in favour of treating voice as a purely syntactic phenomenon. In particular, I discussed examples where semantics appears to be a factor (e.g. the *a-* passive) and argued that semantics plays a role in determining where arguments are projected in the syntax. In other words, there is but an indirect connection between semantics and passive. On the other hand, I do not mean to deny the pragmatic effects of passive on discourse. I have been primarily concerned with passive at the sentence level, not in the context of a text. Further research will determine how to integrate the syntax with the discourse.

In chapter 2, I argued for a particular syntactic position ([Spec, v2P]) for base generating a certain class of arguments. This position, subordinate to agents and superordinate to themes, has the effect of obscuring the theta hierarchy. Moreover, I discussed the differences between this base generated position and a true derived object position,

with reference to other languages. One extension of this analysis would be to investigate this position in a range of languages. Is there some semantic similarity to the elements that are generated in [Spec, v2P] or is it simply a “wild card” position? Is it possible to support the proposed difference between base generation and movement cross-linguistically? How does this affect the analysis of applicative and other derived object constructions?

Chapter 3 continued the syntactic view of voice. I focussed on the circumstantial topic, which is unusual from the perspective of English active-passive alternations. The key to the proposed analysis is that CT is an “elsewhere” voice. Elsewhere conditions are well-studied in the domain of phonology and morphology, but it remains to be seen just how this notion may be applied to syntax. One further consequence of the proposed analysis is a rethinking of the EPP in Malagasy compared with other verb-initial languages. Are some verb-initial languages (like Niuean) uniquely predicate-fronting, while others (like Malagasy) have both predicate and argument movement? Is there a difference between subject and object movement? Evidence for these distinctions will come from adverb placement and the positional properties of arguments in these languages.

Just as chapter 2 argued for an articulated VP, chapter 4 presented evidence in favour of an articulated CP. Certain extracted elements, including topic and focus, appear in the CP projection. Moreover, I argued that in focus constructions, it is a predicate and not an argument that appears in the pivot position. I also presented evidence in favour of a topic position below focus, the “bodyguard”. Importantly, it is the A movement of the voice system, outlined in chapters 1-3, that feeds the A-bar movement of topic and focus. In order to investigate the latter, we must first understand the former. I hope that this thesis has provided some insight into both the A and the A-bar systems of Malagasy.

Combining the results of chapters 2-4, we get the following picture of Malagasy clause structure.

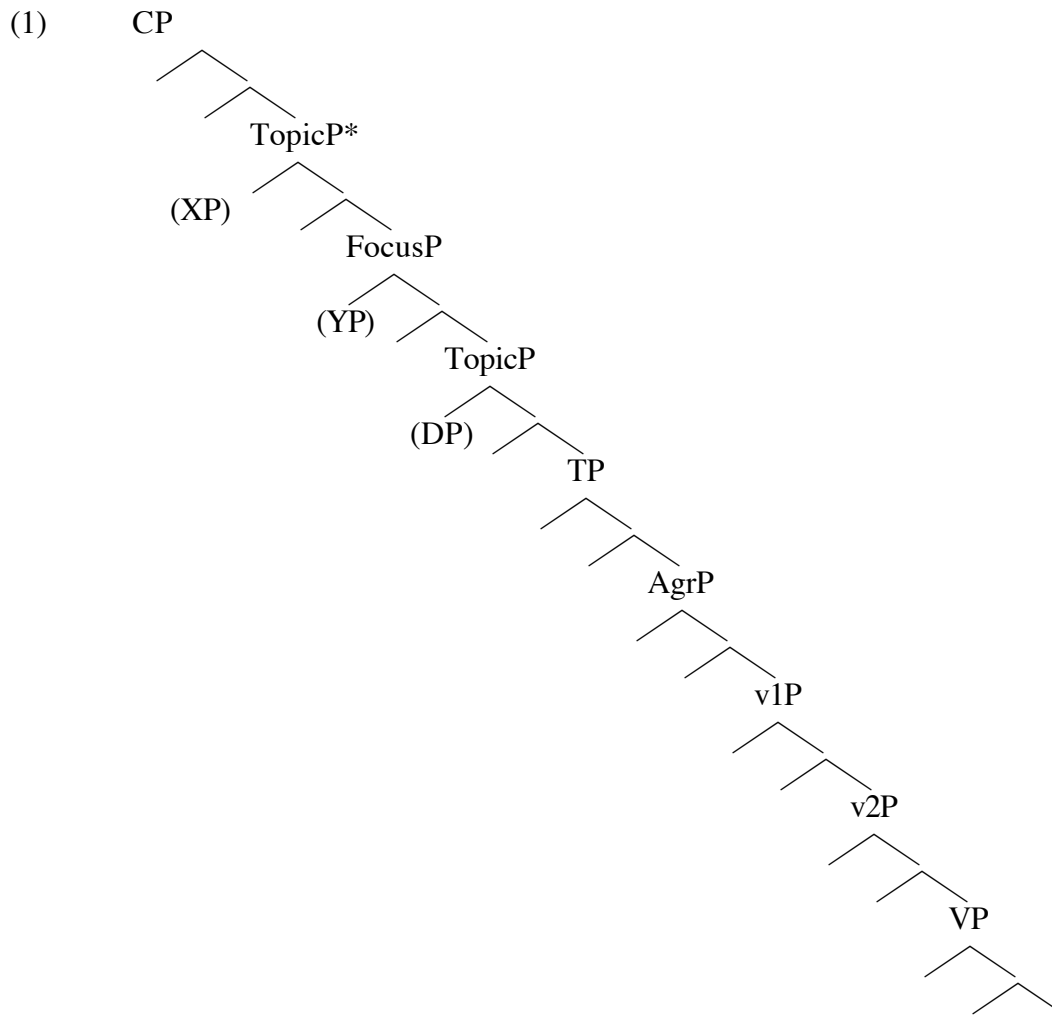

Just as the tree in (1) represents only the bare bones of the clause, so this thesis is but the first step towards a better understanding of Malagasy grammar. Once this initial groundwork is in place, however, more detailed analyses will follow.

Appendix

In chapter 2, I address the different passive forms, *a-* and *-Vna*. In the following tables, I provide further examples of the verbs associated with these affixes. Table 1 combines the other four - it gives a range of the verbs that have the *a-* passive. Table 2 shows those verbs which just have the *a-* passive. Tables 3-5 illustrate the verbs that have both the *a-* and *-Vna* passives. These tables are not exhaustive, but are intended to show as wide a range as possible to supplement the examples in chapter 2.

Table 1: *a-* passive verbs

root	active verb	meaning	subject of <i>a-</i> passive	subject of <i>-Vna</i> passive	subject of CT
didy	mandidy	‘cut’	instr	theme	instr
doboka	mandoboka	‘beat’	instr	theme	instr
dona	mandona	‘beat’	instr	theme	instr
fafa	mamafa	‘sweep’	instr	theme	instr
fafy	mamafy	‘sow’	mat theme	goal	neither
fahana	mamahana	‘feed’	mat theme	goal	mat theme
fatratra	mamatratra	‘stuff’	mat theme	goal	mat theme
fehy	mamehy	‘tie’	mat theme	goal	mat theme
fefy	mamefy	‘fence in’	mat theme	goal	mat theme
feno	mameno	‘fill’	mat theme	goal	mat theme
idina	midina	‘lower’	theme	n/a	goal
jery	mijery	‘watch’	instr	theme	instr
joro	manajoro	‘raise’	theme	n/a	loc
kapa	mikapa	‘cut’	instr	theme	instr
kapoka	mikapoka	‘hit’	instr	theme	instr
lafika	mandafika	‘pad’	mat theme	goal	mat theme
lahatra	mandahatra	‘line up’	theme	n/a	goal
latsaka	mandatsaka	‘drop’	theme	n/a	goal

root	active verb	meaning	subject of <i>a-</i> passive	subject of - <i>Vna</i> passive	subject of CT
lavo	mandavo	‘spill’	theme	n/a	goal
lefa	mandefa	‘send’	theme	n/a	goal
loko	mandoko	‘paint’	instr	theme	instr
orina	manorina	‘erect’	theme	n/a	loc
petraka	mametraka	‘place’	theme	n/a	loc
rakotra	mandrakotra	‘cover’	mat theme	goal	mat theme
raraka	mandraraka	‘scatter’	mat theme	goal	neither
roso	mandroso	‘serve’	theme	goal	goal
sasa	manasa	‘wash’	instr	theme	instr
seho	manaseho	‘show’	theme	goal	goal
solo	manolo	‘change’	mat theme	goal	mat theme
tafy	manafy	‘clothe’	mat theme	goal	mat theme
tafo	manafo	‘roof’	mat theme	goal	mat theme
tolotra	manolotra	‘offer’	theme	goal	goal
toro	manoro	‘point out’	theme	goal	goal
tondraka	manondraka	‘water’	mat theme	goal	mat theme
tototra	manototra	‘fill’	mat theme	goal	mat theme
traka	mandraka	‘raise’	theme	n/a	loc
tsindrona	manindrona	‘pierce’	instr	theme	instr
tsipy	manipy	‘throw’	theme	n/a	goal
valy	mamaly	‘answer’	theme	goal	neither
velatra	mamelatra	‘unroll’	theme	theme/goal	goal
verina	mamerina	‘return’	theme	n/a	goal
vono	mamono	‘kill’	instr	theme	instr

Appendix

Table 2: verbs with only *a-* passive

root	active verb	meaning	subject of <i>a-</i> passive	subject of - <i>Vna</i> passive	subject of CT
idina	midina	‘lower’	theme	n/a	loc
joro	manajoro	‘raise’	theme	n/a	loc
lahatra	mandahatra	‘line up’	theme	n/a	loc
latsaka	mandatsaka	‘drop’	theme	n/a	loc
lavo	mandavo	‘spill’	theme	n/a	loc
orina	manorina	‘build’	theme	n/a	loc
petraka	mametraka	‘place’	theme	n/a	loc
traka	mandraka	‘raise’	theme	n/a	loc
tsipy	manipy	‘throw’	theme	n/a	loc
verina	mamerina	‘return’	theme	n/a	goal

Table 3: Case I verbs (instrumental advancement)

root	active verb	meaning	subject of <i>a-</i> passive	subject of - <i>Vna</i> passive	subject of CT
didy	mandidy	‘cut’	instr	theme	instr
doboka	mandoboka	‘beat’	instr	theme	instr
dona	mandona	‘beat’	instr	theme	instr
fafa	mamafa	‘sweep’	instr	theme	instr
jery	mijery	‘watch’	instr	theme	instr
kapa	mikapa	‘cut’	instr	theme	instr
kapoka	mikapoka	‘hit’	instr	theme	instr
loko	mandoko	‘paint’	instr	theme	instr
sasa	manasa	‘wash’	instr	theme	instr
tsindrona	manindrona	‘pierce’	instr	theme	instr
vono	mamono	‘kill’	instr	theme	instr

These verbs all allow the instrument to appear in an “advanced” position.

- (1) Manasa savony ny lamba Rakoto.
AT.wash soap det cloth Rakoto
'Rakoto washes the clothes with soap.'

- (2) Namono langilangy ny voalavo Rasoa.
pst.AT.kill stick det rat Rasoa
'Rasoa killed the rat with a stick.'

- (3) Nikapoka langilangy ny rindrina i Bakoly.
pst.AT.hit stick det wall Bakoly
'Bakoly hit the wall with a stick.'

- (4) Nikapa famaky ny hazo i Soa.
pst.AT.cut ax det tree Soa
'Soa cut the tree with an ax.'

- (5) Nandoko loko mena ny tranony i Sahondra.
pst.AT.paint colour red det house.3(gen) Sahondra
'Sahondra painted her house with red paint.'

Table 4: Case II verbs (locative alternation)

root	active verb	meaning	subject of <i>a-</i> passive	subject of - <i>Vna</i> passive	subject of CT
fafy	mamafy	'sow'	mat theme	goal	neither
fahana	mamahana	'feed'	mat theme	goal	mat theme
fatratra	mamatratra	'stuff'	mat theme	goal	mat theme
fehny	mamehy	'tie'	mat theme	goal	mat theme
fefy	mamefy	'fence in'	mat theme	goal	mat theme
feno	mameno	'fill'	mat theme	goal	mat theme
lafika	mandafika	'pad'	mat theme	goal	mat theme
rakotra	mandrakotra	'cover'	mat theme	goal	mat theme
raraka	mandraraka	'scatter'	mat theme	goal	neither
tafy	manafy	'clothe'	mat theme	goal	mat theme
tafo	manafo	'roof'	mat theme	goal	mat theme
tondraka	manondraka	'water'	mat theme	goal	mat theme
tototra	manototra	'fill'	mat theme	goal	mat theme

Unlike instruments, material themes are compatible with an instrument PP.

- (6) Manafo bozaka ny trano amin'ny maritao i Sahondra.
 AT.roof grass det house P.gen.det hammer Sahondra
 'Sahondra roofs the house with straw with the hammer.'
- (7) Nanotora fasika ny hady tamin'ny angady Rasoana.
 pst.AT.fill sand det ditch pst.P.gen.det shovel Rasoana
 'Rasoana fill sand into the ditch with the shovel.'
- (8) Namafy voa ny saha tamin'ny tanany i Bakoly.
 pst.AT.sow seed det field pst.P.gen.det hand.3(gen) Bakoly
 'Bakoly sowed seeds in the field with her hand.'

Table 5: Case III verbs (dative shift)

root	active verb	meaning	subject of <i>a-</i> passive	subject of - <i>Vna</i> passive	subject of CT
roso	mandroso	'serve'	theme	goal	goal
seho	manaseho	'show'	theme	goal	goal
solo	manolo	'change'	theme	goal	goal
tolotra	manolotra	'offer'	theme	goal	goal
toro	manoro	'point out'	theme	goal	goal
valy	mamaly	'answer'	theme	goal	neither
velatra	mamelatra	'unroll'	theme	theme/goal	goal

References

- Abinal, R.P. and S.J. Malzac. 1888. *Dictionnaire Malgache-Français*. Fianarantsoa.
- Aissen, Judith. 1992. Topic and focus in Mayan. *Language* 68: 43-79.
- Anderson, Stephen. 1971. On the role of Deep Structure in semantic interpretation. *Foundations of Language* 6: 197-219.
- Andriamierenana, Clément Luc. 1996. Morphological causatives in Malagasy. In *UCLA Occasional Papers in Linguistics, 17: The structure of Malagasy*, Eds. M. Pearson and I. Paul: 58-75.
- Baker, Mark. 1988. *Incorporation: A theory of grammatical function changing*. Chicago: University of Chicago Press.
- Baker, Mark. 1992. Thematic constraints on syntactic structures: Evidence from locative applicatives. In *Thematic structure: Its role in grammar*, Ed. I. M. Roca: 23-46. Berlin: Foris.
- Baker, Mark. 1996a. On the structural position of themes and goals. In *Phrase structure and the Lexicon*, Eds. L. Zaring and J. Rooryck: 7-34. Dordrecht: Kluwer Academic Press.
- Baker, Mark. 1996b. *The polysynthesis parameter*. Oxford: Oxford University Press.
- Baker, Mark. 1997. Thematic roles and syntactic structure. In *Elements of grammar*, Ed. L. Haegeman: 73-137. Dordrecht: Kluwer.
- Baker, Mark, Kyle Johnson and Ian Roberts. 1989. Passive arguments raised. *Linguistic Inquiry* 20: 219-251.
- Ballard, D. Lee. 1974. The semantics of Inibaloi verbal affixes. *Lingua* 34: 181-218.
- Bell, Sarah. 1976. Cebuano subjects in two frameworks. PhD thesis, Cambridge, MA, MIT.
- Boskovic, Zeljko. 1994. D-structure, theta criterion, and movement into theta positions. *Linguistic Analysis* 24: 247-286.
- Boskovic, Zeljko. 1997. Superiority effects with multiple *wh*-fronting in Serbo-Croatian. *Lingua* 102: 1-20.
- Boskovic, Zeljko. 1998. *Wh*-phrases and *wh*-movement in Slavic. Comparative Slavic Morphosyntax, Bloomington, Indiana.
- Browne, Wayles E. 1972. Conjoined question words and a limitation on English surface structures. *Linguistic Inquiry* 3: 223-226.
- Brunson, Barbara. 1992. Thematic discontinuity. PhD thesis, Toronto, University

- of Toronto.
- Burzio, Luigi. 1986. *Italian syntax*. Dordrecht: Kluwer.
- Carrier-Duncan, Jill. 1985. Linking of thematic roles in derivational word formation. *Linguistic Inquiry* 16: 1-34.
- Cheng, Lisa. 1991. On the typology of wh-questions. PhD thesis, Cambridge, MA, MIT.
- Chomsky, Noam. 1977. On WH-movement. In *Formal syntax*, Eds. P. Culicover, T. Wasow and A. Akmajian: 71-132. New York: Academic Press.
- Chomsky, Noam. 1981. *Lectures on government and binding*. Dordrecht: Foris.
- Chomsky, Noam. 1995. *The minimalist program*. Cambridge, MA: MIT Press.
- Chung, Sandra. 1976a. An object-creating rule in Bahasa Indonesia. *Linguistic Inquiry* 7: 41-87.
- Chung, Sandra. 1976b. On the subject of two passives in Indonesian. In *Subject and topic*, Ed. C. Li. New York: Academic Press.
- Chung, Sandra. 1978. *Case marking and grammatical relations in Polynesian*. Austin: University of Texas Press.
- Cinque, Guglielmo. 1990. *Types of A-bar dependencies*. Cambridge, MA: MIT Press.
- Cole, Peter, Gabriella Hermon and Norhaida Aman. to appear. Clefted questions in Malay. In *Malay/Indonesian linguistics*, Eds. D. Gil and J. Collins. London: Curzon Press.
- Collins, Chris and Höskuldur Thráinsson. 1996. VP-internal structure and object shift in Icelandic. *Linguistic Inquiry* 27: 391-444.
- Comrie, Bernard. 1977. In defense of spontaneous demotion: The impersonal passive. In *Syntax and semantics 8: Grammatical relations*, Eds. P. Cole and J. Sadock. New York: Academic Press.
- Dahl, Otto Christian. 1951. *Malgache et maanjan: Une comparaison linguistique*. Oslo: Egede-Instituttet.
- DiSciullo, Anna-Maria and Edwin Williams. 1987. *On the definition of word*. Cambridge, MA: MIT Press.
- Doetjes, Jenny. 1997. Quantifiers and selection: On the distribution of quantifying expressions in French, Dutch and English. HIL. PhD thesis, Leiden, University of Leiden.
- Dowty, David. 1979. *Word meaning and Montague grammar*. Dordrecht: Reidel.
- Dowty, David. 1991. Thematic proto-roles and argument selection. *Language* 67: 547-619.

References

- É. Kiss, Katalin. 1998. Identificational focus versus information focus. *Language* 74: 245-273.
- Emonds, Joseph. 1987. The invisible category principle. *Linguistic Inquiry* 18: 613-632.
- Enç, Mürvet. 1991. The semantics of specificity. *Linguistic Inquiry* 22: 1-25.
- Erteschik-Shir, Nomi. 1997. *The dynamics of focus structure*. Cambridge: Cambridge University Press.
- Erwin, Sean. 1996. Quantity and moras: An amicable separation. In *UCLA Occasional Papers in Linguistics, 17: The structure of Malagasy*, Eds. M. Pearson and I. Paul: 2-30. Los Angeles: UCLA.
- Fillmore, Charles. 1970. The grammar of *hitting* and *breaking*. In *Readings in English transformational grammar*, Eds. R. Jacobs and P. Rosenbaum: 120-133. Waltham, MA: Ginn.
- Foley, William A. 1976. Comparative syntax in Austronesian. PhD thesis, Berkeley, University of California, Berkeley.
- Georgopoulos, Carol. 1991. *Syntactic variables: Resumptive pronouns and A' binding in Palauan*. Dordrecht: Kluwer.
- Gerds, Donna. 1988. Antipassives and causatives in Ilokano: Evidence for an ergative analysis. In *Studies in Austronesian linguistics*, Ed. R. McGinn: 295-322. Athens, OH: Ohio University Center for International Studies.
- Gibson, Jeanne. 1980. Clause union in Chamorro and Universal Grammar. PhD thesis, San Diego, UC San Diego.
- Goldberg, Adele. 1995. *Constructions: A construction grammar approach to argument structure*. Chicago: University of Chicago Press.
- Gross, Maurice. 1975. *Méthodes en syntaxe*. Paris: Herman.
- Gruber, Jeffrey. 1965. Studies in lexical relations. PhD thesis, Cambridge, MA, MIT.
- Guilfoyle, Eithne, Henrietta Hung and Lisa Travis. 1992. Spec of IP and Spec of VP: Two subjects in Austronesian languages. *Natural Language and Linguistic Theory* 10: 375-414.
- Halpern, Aaron L. and Arnold M. Zwicky, eds. 1996. *Approaching second: Second position clitics and related phenomena*. Stanford: CSLI.
- Hanitriniaina, Saholy and Lisa Travis. 1998. F-nominals in Malagasy and unparsing. CLA, University of Ottawa.
- Hardjadibrata, RR. 1985. *Sundanese: A syntactic analysis*. Canberra: Australian National University.

- Harris, Zellig. 1976. *Notes du cours de syntaxe*. Paris: Seuil.
- Heggie, Lorie. 1993. The range of null operators: Evidence from clefting. *Natural Language and Linguistic Theory* 11: 45-84.
- Hoeksema, Jacob. 1984. Partitives. ms, Groningen.
- Hoekstra, Teun and René Mulder. 1991. Unergatives as copular verbs; locational and existential predication. *The Linguistic Review* 7: 1-79.
- Hornstein, Norbert. 1999. Movement and control. *Linguistic Inquiry* 30: 69-96.
- Jackendoff, Ray. 1972. *Semantic interpretation in generative grammar*. Cambridge, MA: MIT Press.
- Jackendoff, Ray. 1977. *X-bar syntax*. Cambridge, MA: MIT Press.
- Jackendoff, Ray. 1996. The proper treatment of measuring out, telicity, and perhaps even quantification in English. *Natural Language and Linguistic Theory* 14: 305-354.
- Kayne, Richard. 1975. *French syntax: the transformational cycle*. Cambridge, MA: MIT Press.
- Kayne, Richard. 1994. *The antisymmetry of syntax*. Cambridge, MA: MIT Press.
- Keenan, Edward. 1976. Remarkable subjects in Malagasy. In *Subject and topic*, Ed. C. Li: 249-301. New York: Academic Press.
- Keenan, Edward and Maria Polinsky. 1996. Malagasy morphology. In *Handbook of morphology*, Eds. A. Zwicky and A. Spencer: Oxford University Press.
- Keenan, Edward. in press. Morphology is structure: A Malagasy test case. In *Formal issues in Austronesian linguistics*, Eds. I. Paul, V. Phillips and L. Travis: 23-41. Dordrecht: Kluwer.
- Kiparsky, Paul. 1995. Partitive case and aspect. ms, Stanford University.
- Kroeger, Paul. 1990. The morphology of affectedness in Kimaragang Dusun. ms.
- Kroeger, Paul. 1993. *Phrase structure and grammatical relations in Tagalog*. Stanford, CA: Center for the Study of Language and Information.
- Ladusaw, William. 1982. Semantic constraints on the English partitive construction. WCCFL I, Stanford University.
- Lakoff, George. 1968. Instrumental adverbs and the concept of deep structure. *Foundations of Language* 4: 4-29.
- Larson, Richard. 1985. Bare-NP adverbs. *Linguistics Inquiry* 16: 595-621.
- Larson, Richard. 1988. On the double object construction. *Linguistic Inquiry* 19: 335-391.
- Maclachlan, Anna. 1996. Aspects of ergativity in Tagalog. PhD thesis, Montreal, Canada, McGill University.

References

- Maclachlan, Anna and Masanori Nakamura. 1997. Case checking and specificity in Tagalog. *The Linguistic Review* 14: 307-333.
- Malzac, R.P. 1960. *Grammaire Malgache*. Paris: Société d'Éditions Géographiques, Maritimes et Coloniales.
- Manorohanta, Cécile. 1998. A quantitative study of voice in Malagasy. AFLA-V, University of Hawai'i.
- Marantz, Alec. 1984. *On the nature of grammatical relations*. Cambridge, MA: MIT Press.
- Marantz, Alec. 1993. Implications of asymmetries in double object constructions. In *Theoretical aspects of Bantu grammar*, Ed. S. A. Mchombo: 113-150. Stanford: CSLA Publications.
- Massam, Diane. 1998. Instrumental *aki* and the nature of Niuean transitivity. *Oceanic Linguistics* 37: 1-17.
- Massam, Diane. to appear. VSO is VOS: Aspects of Niuean word order. In *The syntax of verb-initial languages*, Eds. A. Carnie and E. Guilfoyle. Oxford: Oxford University Press.
- Massam, Diane and Carolyn Smallwood. 1996. Essential features of predication in English and Niuean. NELS 27, McGill University, Montreal, GLSA.
- Matsuoka, Mikinari. 1999. Two independent positions for dative arguments. CLA, University of Sherbrooke.
- McCawley, James. 1988. Adverbial NPs: Bare or clad in see-through garb? *Language* 64: 583-590.
- Nakamura, Masanori. 1996. Economy of chain formation. PhD thesis, Montreal, Canada, McGill University.
- Naumann, Ralf and Anja Latrouite. 1999. On the interpretation of Tagalog voice affixes. AFLA VI, University of Toronto, Holland Academic Graphics.
- Paul, Ileana. 1996a. The active marker and nasals in Malagasy. In *UCLA Occasional Papers in Linguistics, 17: The structure of Malagasy, Vol. 1*, Eds. M. Pearson and I. Paul: 49-57.
- Paul, Ileana. 1996b. F-words and other (Malagasy) nominals. CLA, Brock University, Calgary Working Papers in Linguistics.
- Paul, Ileana. 1996c. The Malagasy genitive. In *UCLA Occasional Papers in Linguistics, 17: The structure of Malagasy, Vol. 1*, Eds. M. Pearson and I. Paul: 76-91.
- Paul, Ileana. 1997. Malagasy existentials: Specificity and partitivity. ms, McGill University.

- Paul, Ileana. 1998. Focus movement and *wh*-questions in Malagasy. WECOL, Arizona State University.
- Paul, Ileana. in press. Malagasy existentials: A syntactic account of specificity. In *Formal issues in Austronesian linguistics*, Eds. I. Paul, V. Phillips and L. Travis: 57-74. Dordrecht: Kluwer.
- Pearce, Elizabeth. 1999. Topic and focus in a head-initial language: Maori. AFLA VI, University of Toronto, Toronto Working Papers in Linguistics.
- Pearson, Matt. 1996a. Domain phrases and topic arguments in Malagasy existentials. In *UCLA Occasional Papers in Linguistics, 17: The structure of Malagasy*, Eds. M. Pearson and I. Paul: 113-141.
- Pearson, Matt. 1996b. Pied-piping into the left periphery. NELS 27, McGill University, Montreal, Canada, GLSA.
- Pearson, Matt. 1996c. Raising and restructuring in Malagasy existentials. MA thesis, Los Angeles, CA, UCLA.
- Pearson, Matt. 1998a. Event structure and the syntax of themes and instruments: The case of the Malagasy Translative Voice (*a*-passive). AFLA-V, University of Hawai'i.
- Pearson, Matt. 1998b. Predicate raising and VOS order in Malagasy. In *UCLA Occasional Papers in Linguistics, 20: The structure of Malagasy, Vol. 2*, Ed. I. Paul. Los Angeles: UCLA.
- Pearson, Matt. 1999. Direct and inverse order languages. GLOW, Berlin.
- Pearson, Matt. forthcoming. Word order and the syntax of events: The case of the Malagasy predicate. PhD thesis, Los Angeles, UCLA.
- Pearson, Matt. to appear. Two types of VO languages. In *OV and VO*, Ed. P. Svenonius. Amsterdam: John Benjamins.
- Pensalfini, Robert. 1995. Malagasy phrase structure and the LCA. In *MITWPL 27: Papers on minimalist syntax*, Eds. R. Pensalfini and H. Ura.
- Perlmutter, David and Paul Postal. 1977. Toward a universal characterization of passivization. Proceedings of the Third Annual Meeting of the Berkeley Linguistics Society, University of California Berkeley.
- Pesetsky, David. 1987. Wh-in-situ: Movement and unselective binding. In *The representation of (in)definiteness*, Eds. E. J. Reuland and A. ter Meulen: 98-129. Cambridge, MA: MIT Press.
- Phillips, Vivianne. in press. The interactions between prefix and root: The case of *maha-* in Malagasy. In *Formal issues in Austronesian linguistics*, Eds. I. Paul, V. Phillips and L. Travis: 75-92. Dordrecht: Kluwer.

References

- Polinsky, Maria. 1994. The existential construction in Malagasy. Seventh International Congress of Austronesian Linguistics, Leiden.
- Pollock, Jean-Yves. 1989. Verb movement, Universal Grammar and the structure of IP. *Linguistic Inquiry* 20: 365-424.
- Postal, Paul. 1969. Anaphoric islands. CLS 5, University of Chicago.
- Rabenilaina, Roger-Bruno. 1985. Lexique-grammaire du malgache. Constructions transitives et intransitives. Thèse de doctorat d'état, Paris, Université Paris VII.
- Rabenilaina, Roger-Bruno. 1991. Voix et diathèse en malgache. *Linguisticae Investigationes* 15: 325-335.
- Rackowski, Andrea. 1998. Malagasy adverbs. In *UCLA Occasional Papers in Linguistics, 20: The structure of Malagasy, Vol. 2*, Ed. I. Paul. Los Angeles: UCLA.
- Rackowski, Andrea and Lisa Travis. to appear. V-initial languages: X or XP movement and adverbial placement. In *The syntax of verb-initial languages*, Eds. A. Carnie and E. Guilfoyle. Oxford: Oxford University Press.
- Rahajarizafy, Antoine de Padoue. 1960. *Essai de grammaire malgache*. Antanimena Tananarive: Imprimerie Catholique.
- Rahalalaoherivony, B. S. 1995. Lexique-grammaire du malgache: constructions adjectivales. PhD thesis, Paris, Paris VII.
- Raharinirina-Rabaovololona. 1991. Lexique-grammaire des composés du malgache. Les adverbies de temps. PhD thesis, Paris, Paris VII.
- Rajaona, Siméon. 1972. *Structure du malgache: Étude des formes prédicatives*. Fianarantsoa: Librairie Ambozontany.
- Rajemisa-Raolison, Régis. 1966. *Grammaire malgache*. Fianarantsoa: Librairie Ambozontany.
- Randriamasimanana, Charles. 1986. *The causatives of Malagasy*. Honolulu: University of Hawaii Press.
- Rappaport, Malka and Beth Levin. 1988. What to do with theta-roles. In *Syntax and Semantics 21: Thematic relations*, Ed. W. Wilkins: 7-36. New York: Academic Press.
- Reinhart, Tanya. 1981. Pragmatics and linguistics: An analysis of sentence topics. *Philosophica* 27: 53-94.
- Richards, Norvin. 1996. Syntax versus semantics in Tagalog *wh*-movement. In *UCLA Occasional Papers in Linguistics 21: Recent papers in Austronesian linguistics*, Ed. M. Pearson: 259-275. Los Angeles: UCLA.
- Richards, Norvin. 1997. What moves where when in which language? PhD thesis,

- Cambridge, MA, MIT.
- Rizzi, Luigi. 1990. *Relativized minimality*. Cambridge, MA: MIT Press.
- Rizzi, Luigi. 1997. The fine structure of the left periphery. In *Elements of grammar*, Ed. L. Haegeman: 281-337. Dordrecht: Kluwer.
- Rooth, Mats. 1996. Focus. In *The handbook of contemporary semantic theory*, Ed. S. Lappin: 271-297. Oxford: Blackwell.
- Rudin, Catherine. 1988. On multiple questions and multiple *wh* fronting. *Natural Language and Linguistic Theory* 6: 445-501.
- Saito, Mamoru. 1994. Additional-*wh* effects and the adjunction site theory. *Journal of East Asian Linguistics* 3: 195-240.
- Seiter, William. 1979. Instrumental advancement in Niuean. *Linguistic Inquiry* 10: 595-621.
- Sells, Peter. 1998. The functions of voice markers in the Philippine languages. In *Morphology and its relation to phonology and syntax*, Eds. S. Lapointe, D. Brentari and P. Farrell: 111-137. Stanford: CSLI Publications.
- Shibatani, Masayoshi. 1985. Passives and related constructions: A prototype analysis. *Language* 61: 821-848.
- Sityar, Emily. in press. The topic and *y* indefinite in Cebuano. In *Formal issues in Austronesian linguistics*, Eds. I. Paul, V. Phillips and L. Travis: 131-153. Dordrecht: Kluwer.
- Sproat, Richard. 1988. On anaphoric islandhood. In *Theoretical morphology: Approaches in modern linguistics*, Eds. M. Hammond and M. Noonan: 291-301. New York: Academic Press.
- Stowell, Tim. 1985. Null antecedents and proper government. NELS 16, McGill University.
- Szabolcsi, Anna. 1981. The semantics of topic-focus articulation. In *Formal methods in the study of language*, Eds. J. Groenendijk, T. Janssen and M. Stokhof: 513-541. Amsterdam: Mathematisch Centrum.
- Szabolcsi, Anna and Frans Zwarts. 1992-1993. Weak islands and an algebraic semantics for scope taking. *Natural Language Semantics* 1: 235-284.
- Tanaka, Hidekazu. 1998. Conditions on logical form derivations and representations. PhD thesis, Montreal, Canada, McGill University.
- Tenny, Carol. 1994. *Aspectual roles and the syntax-semantics interface*. Dordrecht: Kluwer.
- Travis, Lisa. 1984. Parameters and effects of word order variation. PhD thesis, Cambridge, MA, MIT.

References

- Travis, Lisa. 1988. The syntax of adverbs. *McGill Working Papers in Linguistics, Special Issue on Comparative Germanic Syntax*: 280-310.
- Travis, Lisa. 1996. Achievements and external theta-role assignment: suggestive data from Malagasy. AFLA-3, UCLA.
- Travis, Lisa. 1997. Theta-positions and binding in Balinese and Malagasy. AFLA-4, UCLA.
- Travis, Lisa. 1999. Objects in Malagasy and in English. The role of grammatical functions in transformational syntax, University of Illinois, Urbana-Champaign.
- Travis, Lisa. in press. The l-syntax/s-syntax boundary: Evidence from Austronesian. In *Formal issues in Austronesian linguistics*, Eds. I. Paul, V. Phillips and L. Travis: 151-175. Dordrecht: Kluwer.
- Travis, Lisa. to appear. T-positions and binding in Balinese and Malagasy. *Canadian Journal of Linguistics*.
- Voskuil, Jan. 1996. *Comparative morphology. Verb taxonomy in Indonesian, Tagalog and Dutch*. Leiden: HIL Dissertations.
- Wechsler, Stephen and I Wayan Arka. 1998. Syntactic ergativity in Balinese: An argument structure based account. *Natural Language and Linguistic Theory* 16: 387-441.
- Wierzbicka, Anna. 1968. On the semantics of the verbal aspect in Polish. In *To honor Roman Jakobson: Essays on the occasion of his seventieth birthday*, 2231-2249. The Hague: Mouton.
- Williams, Edwin. 1980. Predication. *Linguistic Inquiry* 11: 203-238.
- Williams, Edwin. 1981. Argument structure and morphology. *The linguistic review* 1: 81-114.
- Wojcik, R. 1976. Where do instrumental NPs come from? In *Syntax and Semantics 6: The grammar of causative constructions*, Ed. M. Shibatani. New York: Academic Press.
- Zribi-Hertz, Anne and Liliane Mbolatianavalona. 1999. Towards a modular theory of linguistic deficiency: Evidence from Malagasy personal pronouns. *Natural Language and Linguistic Theory* 17: 161-218.
- Zubizarreta, Maria Luisa. 1998. *Prosody, focus, and word order*. Cambridge, MA: MIT Press.