

PHRASE STRUCTURE IN MINIMALIST SYNTAX

by

MASATOSHI KOIZUMI

B.A. International Christian University

(1988)

M.A. The Ohio State University

(1991)

Submitted to the Department of Linguistics and Philosophy
in Partial Fulfillment of the Requirements for
the Degree of

Doctor of Philosophy
at the

MASSACHUSETTS INSTITUTE OF TECHNOLOGY

June 1995

© 1995 Masatoshi Koizumi

All rights reserved

The author hereby grants to MIT permission to reproduce and to
distribute publicly paper and electronic copies of this thesis
document in whole or in part.

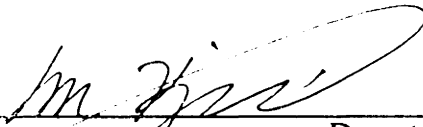
Signature of Author 
Department of Linguistics and Philosophy
March 3, 1995

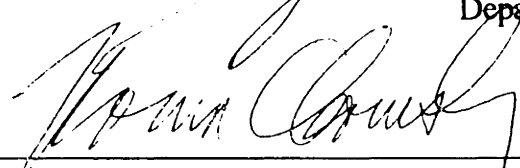
Certified by 
Noam Chomsky
Institute Professor

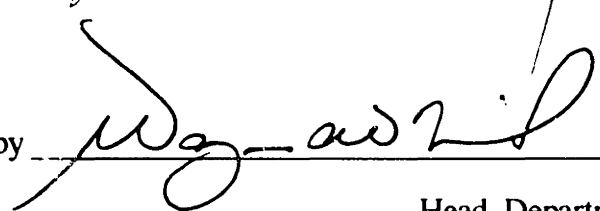
Accepted by 
Wayne O'Neil
Head, Department of Linguistics and Philosophy

MASSACHUSETTS INSTITUTE
OF TECHNOLOGY

JUN 26 1995 ARCHIVES

Phrase Structure in Minimalist Syntax

by

Masatoshi Koizumi

Submitted to the Department of Linguistics and Philosophy
in Partial Fulfillment of the Requirements
of the Degree of Doctor of Philosophy

Abstract

This thesis is a study of clause architecture within a theory of generative grammar. It discusses four major syntactic hypotheses that have crucial bearing on the design of phrase structure: the Agreement-based Case theory, the internal subject hypothesis (ISH), the uniform three-level X-bar theory, and a hypothesis about string vacuous head movement.

In Chapter 2 through Chapter 4, I discuss object positions in three typologically and genetically different languages, i.e. English, Zarma, and Japanese, and argue that they all possess Object Agreement Phrases (AGRoP). A consideration of learnability suggests that the presence of AGRoP in these languages, particularly in Japanese, is not learnable from the data available to children. Thus, it is highly likely that UG is so construed that every language has AGR (THE UNIVERSAL AGR HYPOTHESIS).

In Chapter 5, I turn to subject positions. There is conflicting evidence regarding the base-position of the external argument. Some data indicate that the external argument originates in a position lower than its surface position, as is expected under the internal subject hypothesis. Other data suggest that the base-position of the external argument is outside AGRoP and the VP that dominates the main verb and the internal arguments. If the ISH is correct in that all arguments of a predicate category (e.g. V) originate within the maximal projection of this category, then the apparently contradicting data suggest that there are two verbs, hence two VPs, in a single clause (THE SPLIT VP HYPOTHESIS). One verb is above AGRoP, and the other is below AGRoP. The so-called external argument is an argument of the upper V, and "internal arguments" are arguments of the lower V.

Chapter 6 is concerned with X-bar theory. I argue, contrary to the wide held view, that some functional categories allow more than one specifier position within their projections (LAYERED SPECIFIERS), and that the number of specifiers is different across categories. If this is correct, the X-bar schema as such cannot be a part of Universal Grammar, as already suggested in Fukui (1986) and others. Our claim, however, is crucially different from Fukui's (1986) in that the specifiers of functional categories do not necessarily (but sometimes do) "close off" their projections.

In Chapter 7, I discuss string vacuous verb raising in head final languages. In particular, I present evidence that verbs in Japanese raise out of the VP in overt syntax. Its consequences are also explored to various aspects of syntactic theory such as the Proper Binding Condition, Kayne's (1994) Linear Correspondence Axiom, etc.

Thesis Supervisor: Noam Chomsky
Title: Institute Professor

ACKNOWLEDGMENTS

It is my pleasure to thank the members of my thesis committee: Noam Chomsky (chair), Howard Lasnik, Shigeru Miyagawa, David Pesetsky, and Mamoru Saito. Despite their hectic schedules, they showed extraordinary patience in listening to my many half-baked ideas, reading often sketchy earlier versions of the chapters, and making many helpful suggestions. Noam's influence is quite obvious. Without him, this thesis would never have even begun to be written. Howard's constant demand of precision and details helped me realize that many problems are much more complicated than what they might appear, and that what I said sometimes meant quite different things than I had in mind. Shigeru taught me how to do linguistics over the last several years. I am proud that they say that my linguistics is of "Miyagawa-style." David kindly played a role of devil's advocate, for which I am very grateful. Mamoru's insightful comments led to many improvements. He also showed me by example what the best linguist is like.

To all who taught me at MIT, Suzanne Flynn, Ken Hale, Morris Halle, Jim Harris, Irene Heim, Jim Higginbotham, Michael Kenstowicz, Jay Keyser, Alec Marantz, Wayne O'Neil, Kai von Stechow, Ken Wexler, thanks for four exciting years. Thanks also to Katherine Allen, Carolyn Farrow, Jennifer Furdy, Marilyn Goodrich, Nancy Peters, Rachel Pearl, Bev Stohl, Monique Tasker, Jamie Young, and Wendy Weber, for trying their best to keep me in touch with reality.

I thank my fellow students for exciting discussions, commiseration, and great food: Masha Babyonyshev, Judy Baek, Pilar Barbosa, Jonathan Bobaljik, David Braun., Tony Bures, Andrew Carnie, Chris Collins, Diana Cresti, Hamida Demirdash, Danny Fox, Tom Green, Paul Hagström, Heidi Harley, Doug Jones, Shawn Kern, Miori Kubo, Andrea Leszek, Ingvar Lofstedt, Martha McGinnis, Seth Minkoff, Kumiko Murasugi, Renate Musan, Toshi Oka, Rob Pensalfini, Orin Percus, Colin Phillips, Norvin Richards, V.J. Sarma, Uli Sauerland, Carson Schutze, Hiroaki Tada, Chris Tancredi, Hubert Truckenbrodt, Dylan Tsai, Hiro Ura, Akira Watanabe, Kathleen Williams, Dag Wold, and Brian Yeager. Special *arigatoo* is due to Jonathan, Heidi, Martha, Renate, and Norvin for proofreading the pre-final version.

As is the case with anyone working in any field, I have benefited much from a larger linguistic community beyond MIT. Here are some that come to my mind: Jun Abe, Takako Aikawa, Zeljko Boskovic, Erich Groat, Scott Ferguson, Koji Fujita, Masao Fukuhara, Naoki Fukui, Guenther Grewendorf, Shosuke Haraguchi, Nobuko Hasegawa, Hajime Hoji, Hiroto Hoshi, Koji Hoshi, Sabine Iatridou, Masayuki Ikeuchi, Dianne Jonas, Yasuhiko Kato, Ruriko Kawashima, Akira Kikuchi, Norimi Kimura, Yoshihisa Kitagawa, Hisa Kitahara, Misako Kitamoto, S.-Y. Kuroda, Kazuki Kuwabara, Hideki Maki, Roger Martin, Kazumi Matsuoka, Arthur McCaffrey, Yoichi Miyamoto, Keiko Murasugi, Masaru Nakamura, Naoko Nemoto, Seiichi Nishino, Miyuki Noji, Masayuki Ohkado, Masayuki Oishi, Yukio Otsu, Geoffrey Poole, Keun Won Sohn, Daiko Takahashi, Höskuldur Thráinsson, Shigeo Tonoike, Asako Uchibori, Saeko Urushibara, Hiroko Yamashita, and Kazuko Yatsushiro.

I have been very fortunate to be a student of many people who have influenced my intellectual as well as everyday life. I would like to take this opportunity to thank my former teachers. It was Noriaki Yusa who first told me that there is a branch of science called generative grammar, and to study it I should go to International Christian University. At ICU, I studied with Kazuko Inoue and Masatake Muraki (Old Masa who calls me

Young Masa). Old Masa supervised my B.A. thesis, and sent me to the Ohio State University, where I met Shigeru Miyagawa, J.J. Nakayama, and Peter Culicover, who became the committee members of my M.A. thesis. Shigeru and Peter convinced me to come to MIT despite my initial resistance. I also learnt a lot from Toshio Gunshi, Akio Kamio, Yoshiko Matsumoto, Charles Quinn, and Shelly Quinn.

Finally, and most importantly of all, I wish to thank my parents, Toshiharu and Shizuka Koizumi, for continued moral and financial support.

TABLE OF CONTENTS

CHAPTER ONE: INTRODUCTION	9
1. Outline of the Thesis.....	9
CHAPTER TWO: INVISIBLE AGR IN ENGLISH.....	15
1. Case Adjacency Effects	16
2. Deriving the Adjacency Condition	26
3. The ECM Construction.....	31
4. The Double Object Construction	37
5. Some Differences between English and French.....	41
CHAPTER THREE: INVISIBLE AGR IN ZARMA	47
1. Basic Word Orders	47
2. Adverb Placement.....	52
3. The Double Object Construction	57
CHAPTER FOUR: INVISIBLE AGR IN JAPANESE.....	59
1. Syntactic Compounds.....	59
1.1. Raising vs. Control	60
1.2. Stative Compounds	66
2. A Minimalist Account	70
2.1. Three-layered Case Theory.....	71
2.2. Derivations	74
3. Alternative Analyses.....	78
3.1. Quantifier Raising	79
3.2. Complex Control Predicates as Lexical Compounds.....	81
4. Consequences	84
4.1. Control Predicates without Accusative Case-features.....	84
4.2. Tensed Embedded Clauses.....	87
4.3. Multiple Embedding.....	88
4.4. Causative Constructions.....	90
5. Conclusion.....	97
CHAPTER FIVE: THE SPLIT VP HYPOTHESIS.....	99
1. A Split VP Hypothesis	101
2. Motivations for the Split VP Hypothesis.....	105
2.1. Quantifier Float	105
2.2. Relativized Minimality	110
2.3. Participle Agreement	113
2.4. Chain Condition	115
3. Arguments for the Internal Subject Hypothesis Revisited	119
3.1. Simplification of θ -marking.....	119
3.2. INFL as a Raising Category	120
3.3. VP Coordination.	121

3.4. Reconstruction Effects.....	122
3.5. Quantifier Float.....	123
4. Can the Domain Extension Convention Be Eliminated?.....	125
5. Conclusion.....	129
Appendix to Chapter Five: Related Proposals.....	129
CHAPTER SIX: LAYERED SPECIFIERS.....	137
1. Double-Layered Specifiers.....	138
1.1. Topicalization in English.....	138
1.2. Embedded V2.....	147
2. Multiply-Layered Specifiers.....	152
2.1. Multiple WH Fronting.....	153
2.2. Multiple Subjects.....	158
3. Double-Multiply-Layered Specifiers.....	160
4. Conclusion.....	163
CHAPTER SEVEN: STRING VACUOUS OVERT VERB RAISING.....	165
1. Overt Verb Raising in Japanese.....	166
1.1. Clefting.....	166
1.2. Coordination.....	170
2. Apparent Alternative Analyses.....	174
2.1. Gapping.....	174
2.2. Right-Node-Raising.....	176
3. Consequences.....	178
3.1. Restructuring.....	178
3.2. Complex Predicate Formation.....	181
3.3. Proper Binding Condition.....	185
3.4. Multiple Long-distance Scrambling as Remnant Scrambling.....	194
3.5. Are Floating Quantifiers Floating?.....	197
3.6. Is Japanese SVO?.....	201
4. Conclusion.....	203
Appendices to Chapter Seven.....	204
A. Numeral Quantifiers and the Conjunctive Particle.....	204
B. On the Uncleftability of the Lower VP in English.....	207
C. Traces Not Created by Movement.....	209
REFERENCES.....	213

CHAPTER ONE

INTRODUCTION

This thesis is a study of clause architecture within a framework of generative grammar that has been called the "minimalist framework" or the "minimalist program". Throughout the following discussion, basic familiarity with the framework is presupposed on the part of the reader.¹ In this introductory chapter, I will present a brief outline of the content of the thesis.

1. Outline of the Thesis

Extending X-bar theory to non-lexical or functional categories, Chomsky (1986b) suggests the structure in (1) for a simple transitive sentence.²

(1) [CP C [IP NP_S I [VP V NP_O]]] (linear order irrelevant)

The X-bar theory assumed in Chomsky (1986b) is a version of so-called uniform X-bar theory. Its X-bar schema is shown in (2), where the number of the bars for the maximal projection is uniformly two across categories.³

(2) a. $X' = X X''$
b. $X'' = X'' X'$

¹ For an exposition of the minimalist program, the reader is referred to, among others, Chomsky (1993b; 1994; 1995), Chomsky & Lasnik (1993), and Lasnik (1993). The papers in Bobaljik & Phillips (1993) and Phillips (1993) address issues concerning various aspects of this framework. Kitahara (1994) and Marantz (1995) may serve as an lucid introduction. For a more general consideration of grammar, see Chomsky (1993a), for example.

² The idea that S is IP is originally due to Stowell (1981: Chapter 2) and Pesetsky (1982: Chapter 3). For S' as CP, see Stowell (1981: Chapter 6) and Emonds (1985), among others.

³ Chomsky (1986b) basically adopts Kayne's (1984) proposal that X'' is one or zero occurrence of X', i.e. "binary branching".

Among the most influential hypotheses proposed since then about clause architecture are the Internal Subject Hypothesis (Fukui and Speas 1986; Kitagawa 1986; Koopman and Sportiche 1991; Kuroda 1988; Zagana 1988), and the Split Infl Hypothesis (Pollock 1989; Chomsky 1991). According to the ISH, the original position of the subject is within a projection of the verb, as shown in (3).

(3) [CP C [IP I [VP NP_S [V NP_O]]]]

Pollock (1989) proposes to "split" I(nfl) into two separate categories, T(ense) and AGR(ement); the central motivation being that if we assume that T and AGR occupy two distinct head positions in a clause, certain differences of adverbial distributions (and differences in the relative positions of V and Negation) among languages (e.g. English vs. French) and among clause types (e.g. finite vs. nonfinite) can be attributed to differences as to how far the verb raises in overt syntax. Chomsky (1991) further argues that a single clause contains two, rather than one, Agreement Phrases separated by TP. The higher AGR(P) is referred to as AGR_S(P), and the lower as AGR_O(P):

(4) [CP C [AGR_SP AGR_S [TP T [AGR_OP AGR_O [VP NP_S V NP_O]]]]]

The recent minimalist framework basically adopts this structure (Chomsky 1993b; 1994).

Despite their popularity in the literature, the uniform X-bar theory, the split Infl hypothesis, and the internal subject hypothesis have all been highly controversial. For example, Fukui (1986) questions the existence of X-bar schema in the grammar. Iatridou (1990) argues that all the English and French data that Pollock uses to motivate AGR(P) (and overt verb movement) can and must be explained otherwise, hence there is no evidence that these languages have AGR as a separate syntactic terminal node. Nakayama & Koizumi (1991) present evidence from Japanese that the subject originates outside the VP that dominates the main verb and the object.

In this thesis I address these issues as they are concerned with the central property of Universal Grammar, i.e. phrase structure. In Chapter 2 through Chapter 4, I discuss object positions in three typologically and genetically different languages (English, Zarma, and Japanese), and argue that they all possess AGR_OP as characterized in the minimalist framework. The presence of AGR_OP in these languages, particularly in Japanese, does not seem to be learnable from the data available to children. Thus, it is highly likely that UG is so construed that every language has AGR (THE UNIVERSAL AGR HYPOTHESIS).

In Chapter 5, I turn to subject positions. There is conflicting evidence regarding the base-position of the external argument. Some data indicate that the external argument originates in a position lower than its surface position, as is expected under the internal subject hypothesis. Other data suggest that the base-position of the external argument is outside AGRoP and the VP that dominates the main verb and the internal arguments. If the ISH is correct in that all arguments of a predicate category (e.g. V) originate within the maximal projection of this category, then the apparently contradicting data suggest that there are two verbs, hence two VPs, in a single clause. One VP dominates, and the other one is dominated by, AGRoP. The external argument in the sense of Williams (1981) is generated in the Spec of the upper V (call it V^u for ease of reference), and the internal arguments are generated within the projection of the lower V (V^l). The structure of a simple transitive clause, then, looks like (5).

- (5) [CP C [AGRsP AGRs [TP T [VP NP_S V^u [AGRoP AGRo [VP V^l NP_O]]]]]]
 (linear order irrelevant)

I refer to this proposal as THE SPLIT VP HYPOTHESIS.

Chapter 6 is concerned with X-bar theory. I argue that some functional categories allow more than one specifier position within their projections (LAYERED SPECIFIERS), and the number of specifiers is different across categories. If this is correct, the X-bar schema as such cannot be a part of Universal Grammar. The elimination of the X-bar schema has already been suggested in Fukui (1986) and others. Our position, however, crucially differs from Fukui's (1986) in claiming that the specifiers of functional categories do not necessarily "close off" their projections, although they sometimes do.

In Chapter 7, I discuss overt verb raising in head final languages. In particular, I present evidence that verbs in Japanese move out of the VP in overt syntax, and explore its consequences to various aspects of syntactic theory such as the Proper Binding Condition and Kayne's (1994) Linear Correspondence Axiom.

The definitions of some relevant notions are given below.

- (6) a. The category α *dominates* β if every segment of α dominates β .
 b. The category α *contains* β if some segment of α dominates β .
 c. *MAX* (α), where α is a head, is the least full-category maximal projection dominating α .

- d. The *domain* of a head chain $CH = (\alpha_1, \dots, \alpha_n)$ is the set of nodes contained in $MAX(\alpha_1)$ and not containing any α_i .
- e. $MIN(S)$, S a set of categories, is the smallest subset K of S such that for any $\gamma \in S$, some $\beta \in K$ reflexively contains γ .⁴
- f. The *checking domain* of α is the minimal residue of α .
- g. The *residue* of α is the domain of α minus the complement domain of α .
- h. The *complement domain* of a head chain $CH = (\alpha_1, \dots, \alpha_n)$ is the subset of the domain reflexively dominated the complement of α_n .

These definitions are all taken from Chomsky (1993b), except for (6)e and (6)h which are slight modifications of his originals given in (7).

- (7) a. $MIN(S)$, S a set of categories, is the smallest subset K of S such that for any $\gamma \in S$, some $\beta \in K$ reflexively **dominates** γ .
- b. The *complement domain* of a head chain $CH = (\alpha_1, \dots, \alpha_n)$ is the subset of the domain reflexively dominated by the complement of α_1 .

Consider the structure (8).

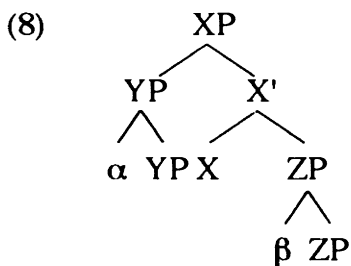

Under Chomsky's original definition in (7)a, α and β as well as the category (as opposed to a segment) YP and the category ZP are in the minimal domain of X . Under our definition in (6)e, neither α nor β is in the minimal domain of X . The minimal domain of

⁴ The definitions of the reflexive domination and the reflexive containment are given below.

- (i) a. α *reflexively dominates* α and everything dominated by α .
- b. α *reflexively contains* α and everything contained in α .

X in (8) consists solely of the category YP and the category ZP. We will discuss a motivation for this modification in Chapter 6.

Next consider the structure (9).

(9) [YP β [Y' Y γ]]

In this structure, γ is in the complement domain of Y, and β is in the checking domain of Y, in both (6)h and (7)b. If Y raises to X as in (10), then, under Chomsky's original definition, β and γ are both in the complement domain of Y, and α is in the checking domain of Y (as well as the checking domain of X).

(10) [XP α [X' [X Y X] [YP β [Y' t_y γ]]]]

Under our definition (6)h, γ but not β is in the complement domain of Y, and α and β are both in the checking domain of Y. Thus, after Y raises to X, β is in the complement domain of Y under Chomsky's (1993b) definition, whereas it is in the checking domain of Y under our definition. This revision is necessarily for languages like French, for example, in which AGRO raises to T in overt syntax but the object raises to the Spec of AGRO only in LF. If the Spec of AGRO is not in the checking domain of AGRO after AGRO raises to T, the ϕ -features of the object cannot be checked off.

CHAPTER TWO

INVISIBLE AGR IN ENGLISH

In Government and Binding Theory (Chomsky 1981; 1982; 1986a; 1986b), it is assumed that structural Case may be licensed in several distinct configurations. In English, for example, structural Nominative Case is considered to be licensed by Infl in the Spec-head relation as in (1)a, whereas structural Accusative Case is considered to be licensed by a verb either in the head-complement relation as in (1)b or in the "ECM relation" as in (1)c.

(1) Government-based Case Theory

a. Spec-head

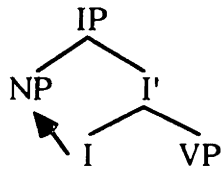

b. Head-complement

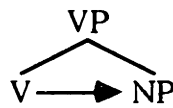

c. ECM

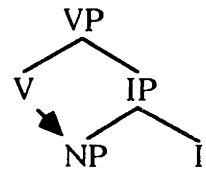

The term "government" is designated to refer to some or all of these configurational relations.

Chomsky (1991; 1993b) suggested reducing the second and the third structural relations to the first one. More precisely, he suggested that structural Case licensing is invariably a Spec-head relation with a functional head. Thus, in English, Nominative Case is licensed by Tense+AGR(eement), and Accusative by Verb+AGR, both in the Spec-head relation, as shown in (2).

(2) Agreement-based Case Theory

a. Spec-head

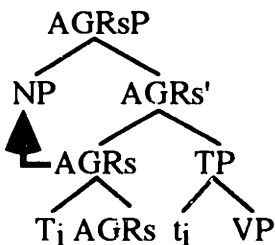

b. Spec-head

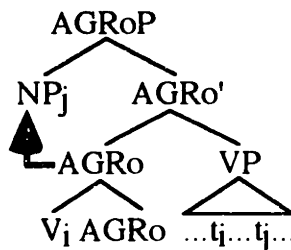

c. Spec-head

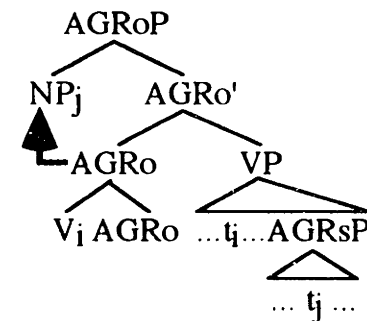

Under this proposal, structural Case licensing is stated in terms of a purely core X'-relation, i.e. Spec-head relation. Despite some skeptics (e.g. Iatridou 1990), empirical evidence has been accumulated for the Agreement-based Case theory, in Germanic, Romance and some other languages (See papers in Bobaljik and Phillips 1993; and Phillips 1993). For instance, it is by now fairly well-established that the object and the ECM subject in Icelandic may move to the Spec of AGRo (or some such position) in overt syntax (cf. Jonas and Bobaljik 1993; Collins and Thráinsson 1993; Harley 1994, and references cited therein).

Agreement-based Case theory has attracted less attention in the field of languages without visible/audible agreement morphology such as Japanese. This is partly due to the wide-spread belief that languages without overt agreement morphology could not possibly have *Agreement* Phrases. Similar objections have been raised against the above mentioned hypothesis by Chomsky that English has an Agreement Phrase for the object (AGRoP): English, which does not have visible/audible object-verb agreement, could not possibly have *Object Agreement* Phrases. It seems that researchers tend to believe that, if a language lacks visible/audible (subject/object) agreement morphology, it does not have (subject/object) Agreement Phrases.

I wish to show in this and the subsequent two chapters that this wide-spread, and in a sense quite natural, belief is not correct. More specifically, I present evidence for the existence of Object Agreement Phrases in English (this chapter), Zarma (Chapter 3), and Japanese (Chapter 4). It is further argued that, since the existence of Agreement Phrases in these languages is not learnable from the data available to children, Agreement Phrases must be universal in the sense that it is innately determined by Universal Grammar that every natural language has Agreement Phrases (Chapter 4).

1. Case Adjacency Effects

As observed in Chomsky (1980a; 1981) and Stowell (1981), adverbs may not occur between a verb and its NP complement in English.

- (3) a. * The policeman arrested quickly the thief.
- b. * Becky speaks fluently Chinese.
- c. * Joni saw frequently the movie.

Elaborating on a suggestion in Chomsky (1980a), Stowell (1981: 113) proposed to account for this fact by his Adjacency Condition on Case Assignment, which states that a Case-assigner and a Case-assignee be string adjacent.¹ While their basic insight that the anomaly of (3) has to do with structural Case seems to be correct, the Adjacency Condition itself has a number of empirical and theoretical problems.

First, it presupposes that the structure of the form in (4)a in general is allowed in the grammar of English (and hence in UG) except that it violates the Adjacency Condition.

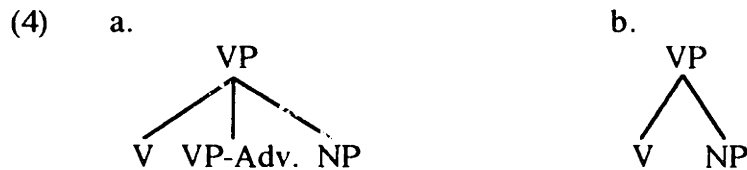

It is not warranted at all, however, that (4)a is not ruled out by some other principles of grammar. For example, the grammar must have some principle that determines the possible positions of adverbs (which, for example, bans manner adverbs in the sentence initial position). This principle alone might suffice to rule out (4)a. In the absence of an explicit theory of adverb placement, it is not clear if we need the Adjacency Condition at all. In fact, (4)a seems to violate at least two principles that have been more or less accepted in the field: the Projection Principle of Chomsky (1981) and the Binary Branching Condition of Kayne (1984). Given the Projection Principle, non-arguments such as VP-adverbs may

¹ Stowell's (1981) project was to eliminate the component of Categorical rules, deriving instead its empirical effects from other components of grammar. The Adjacency Condition was proposed as a part of "other components." Other examples that motivated the Adjacency Condition are given below

- (i) a. * Neil donated to the fund ten dollars.
b. Neil donated ten dollars to the fund.
- (ii) a. * It's possible for tomorrow Sue to speak French.
b. It's possible for Sue to speak French tomorrow.

I will come back to these examples in § 2. I of course agree with the importance and necessity of Stowell's project, and believe that he succeeded brilliantly in it. What I wish to show in the text is that, with more than a decade's advancement of generative grammar after Stowell (1981), now the Adjacency condition as such can, and must, be eliminated, deriving its effects from other components of grammar in a modular manner.

not occur as a sister to a verb.² The Binary Branching Condition bars structures that involve a branching node dominating more than two sisters.³ If one of the two conditions is correct, (4)a will be ruled out independently of the Adjacency Condition, making it superfluous.

Second, suppose, for the sake of discussion, that the structure (4)a does not violate any conditions except the Adjacency Condition, which might be a possibility in light of sentences such as (5).

- (5) a. Brynn spoke loudly with everyone.
 b. Amber looked carefully at him.
 c. Ben relies frequently on it.

(6)

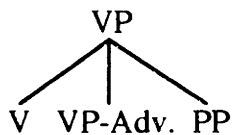

We might suppose that the examples in (3), whose VP structure is (4)a, are ungrammatical because they are in violation of the Adjacency Condition, whereas those in (5), whose VP structure is (6), are grammatical because PPs need not get Case. Even if we grant this, the Adjacency Condition is problematic on conceptual grounds, since most syntactic principles of grammar are stated in terms of hierarchical notions such as "domination" and "c-command" rather than linear notions like "string adjacency". A few cases that appear to refer to the linear order, such as the Head Parameter (+/- Head Initial) etc., are arguably handled in PF. Linearity and adjacency surely play important roles in PF, but they do not seem to be relevant in syntax proper. Even if we admit, for the sake of argument, that "directionality" matters in syntax (e.g. the Head Parameter), there is still no known syntactic conditions crucially referring to "linear adjacency," other than the Adjacency Condition on Case Assignment.⁴ This point alone, of course, does not render the

² It is true, though, that the theoretical status and exact content of the Projection Principle are not clear within the current minimalist framework.

³ This is argued against in Pesetsky (1994).

⁴ A recent proposal by Bobaljik (1994) appeals to the notion of linear adjacency, but crucially adverbs are invisible to his adjacency condition. Besides it is a purely
 (→continue)

Adjacency Condition untenable, but it surely makes it dubious. Note that it is impossible to restate the Adjacency Condition in terms of hierarchical notions (e.g. mutual c-command) without relying on "linear adjacency," since whatever hierarchical-configurational conditions that rule out (4)a will also rule (4)b out, the standardly assumed VP structure of grammatical transitive sentences such as *John cut the orange*.

A third problem with the Adjacency Condition is that it makes empirically wrong predictions in many languages. In English, the subject of a small clause is adjacent to the matrix verb as predicted by the Adjacency Condition. However, in head final languages such as German, the embedded subject and the matrix verb are separated by the embedded predicate, contrary to what is predicted by the Adjacency Condition (Johnson 1992), as shown in (8).⁵

- (7) a. I consider Mary unhappy.
 b. * I consider unhappy Mary.
- (8) a. ...daß ich Studenten dieser Uni für intelligent halte
 that I students of-this university for intelligent hoped
 '...that I consider students of this university intelligent.'
 b. ?* ...daß ich für intelligent Studenten dieser Uni halte
 that I for intelligent students of-this university hoped

To summarize, the Adjacency Condition (i) is not theoretically well motivated, (ii) is implausible on conceptual grounds, and (iii) is empirically incorrect (see Johnson 1991; 1992 for further arguments against the Adjacency Condition). In other words, the Adjacency Condition is more a statement of a problem than a solution thereof.

Several researchers have suggested that the Case adjacency effects in English result from interactions of universal principles and the particular settings of the parameters for this language. Thus, building on the insight of Emonds (1976; 1978), Pollock (1989) developed an analysis of the Case adjacency effects that does not rely on linear adjacency. Pollock suggests that verbs may not move out of the VP in English because of a θ -opaque property of AGR(ement) in English. Given this, the examples in (3) and (5) have the

morphological condition relevant only in the PF side of derivation. Cf. also Stowell's (1981) notion of "Argument-Projection, and Travis' (1984) "argument adjacency."

⁵ (8)b is ungrammatical with a neutral (non-focused) reading (Johnson 1992: fn.7).

structure in (4)a and (6), respectively. The ungrammatical (3) therefore are correctly ruled out by the Projection Principle of Chomsky (1981:38) and/or Kayne's (1994) binary branching condition. A drawback of this analysis is that it incorrectly predicts that the sentences in (5) are also ungrammatical.

One conceivable way out of this problem is to invoke a rightward movement of the PP, as in (9)a. Another possibility is that the verb has moved out of the VP, as in (9)b.

- (9) a. PP movement account
 Brynn [[spoke t_i] loudly] [with everyone]_i;
 b. main verb movement account
 Brynn spoke_i [loudly [t_i with everyone]_i]

While (9)a seems to be a possible structure at least in some cases, Pesetsky (1989) presents several arguments that there are instances in which the structure (9)b must be postulated. Here we reproduce just two of his arguments. First, while an extraction out of PP is possible in (10)a, it becomes impossible if the PP is extraposed, as shown in (10)b (cf. the Condition on Extraction Domain (CED) of Huang 1982).

- (10) a. This is what Bill has now looked at ____
 b. * This is what Bill has looked t_i now [at ____]_i

When a PP occurs to the right of a VP-adverb such as *recently*, the CED effect is not observed ((11)b below). This suggests that the PP has not undergone movement in this case, and that the "VP-Adv. PP" order is a base-generated one, which in turn implies that the sentence involves a leftward main verb movement past the adverb.

- (11) a. This is what Bill has recently looked at ____.
 b. This is what Bill has looked recently at ____.

Second, citing Andrews (1983), Pesetsky notes that when adverbs are stacked on the right periphery of a VP, the adverb to the right takes scope over the adverb to the left (see (12)a and (13)a), and when adverbs are stacked on the left periphery of a VP, the adverb to the left has wider scope ((12)b and (13)b). Thus, with neutral intonation, (12)a refers to two events of intentional knocking, with *twice* modifying the constituent containing *intentionally*. In contrast, (13)b reports the situation in which there was only

one intention, which was to knock twice, with *intentionally* modifying the constituent containing *twice*. These scope facts reflect the hierarchical arrangement of the adverbs under the common assumption that the scope of an adverb is determined in terms of hierarchical structure.

- (12) a. John [[[knocked on the door] intentionally] twice]
 b. (?) John [twice [intentionally [knocked on the door]]]
 (13) a. John [[[knocked on the door] twice] intentionally]
 b. (??) John [intentionally [twice [knocked on the door]]]

(Andrews 1983)

Pesetsky then goes on to observe that when two adverbs occur between a verb and its PP complement, and if the PP is not "heavy" as in (14)a, the adverb to the left has scope over the adverb to the right. This suggests that the adverbs in (14)a, for example, are stacked on the left periphery of the VP, which in turn implies that the verb has moved leftward past the adverbs, as shown in (14)b.⁶

- (14) a. As for Mary, Bill relied intentionally twice on her.
 b. ... relied_i [intentionally [twice [t_i on her]]]

From these and several other pieces of evidence, Pesetsky (1989) concludes that the sentences such as (5) do not (necessarily) involve PP-extrapolation. He then suggests that English main verbs *may* move out of a VP to a higher head position, which he calls μ . This is illustrated in (15)a.

⁶ If the PP is made "heavier", the sentence becomes ambiguous:

- (i) John relied intentionally twice [on the person you told me about].

This is because when the PP is "modestly heavy," as Pesetsky puts it, it can move rightward as in (9)a. The examples in (ii), drawn from Johnson (1991), show that rightward shift of PP is difficult when it is light.

- (ii) a. ?* Sam talked about it calmly to her.
 b. Sam talked about it calmly to the woman with the painted blouse.

(15) a.

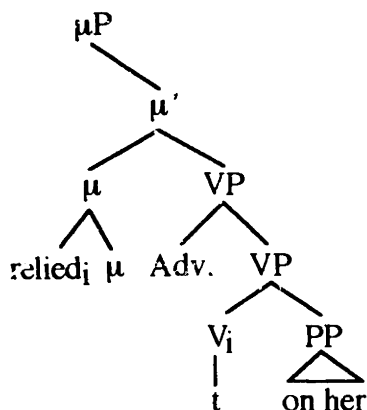

b.

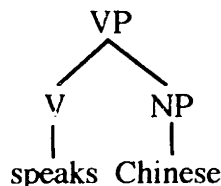

In this analysis, verb movement to μ may but need not take place. In fact, Pesetsky argues that the verb does not raise when the complement is an NP, which needs to be Case-marked by the verb. This is because, μ being Case-opaque, if a verb adjoins to it, neither the verb nor its trace can assign Case to the object NP, leading to a Case Filter violation. Thus, when a verb takes an NP complement, it stays in the VP, as in (15)b above, hence, because of the Projection Principle, adverbs cannot intervene between the verb and the object NP. The examples in (3) are, therefore, ungrammatical.

Although Pesetsky's (1989) analysis neatly accounts for the contrast between (3) and (5), where the verb takes only one complement (an NP or a PP), without resorting to a linear adjacency requirement, it will immediately face difficulties when verbs with more than one complement are taken into consideration. Observe the following sentences.

- (16) a. Bob put all three books intentionally on the table.
b. Aaron gave the ring secretly to her.

In (16), the adverb intervenes between the verb and the PP complement, which, under Pesetsky's analysis, entails that the verb has moved out of the VP to the μ adjoined position. The same sentences also involve NP objects, which entails that the verb remains in the VP. The problem here is that a single verb cannot simultaneously be located within and outside a single VP.⁷

⁷ Another potential problem with Pesetsky's (1989) analysis has to do with the following sentence, which, according to Yoshiki Ogawa (personal communication), is ambiguous, allowing either *intentionally* or *twice* to have wide scope with respect to the other.

(\rightarrow continue)

Following the lead of Pesetsky (1989), Johnson (1991) argues that not only verbs but also object NPs raise in overt syntax. More specifically, he suggests that object NPs move to the Spec of VP to be Case-marked by μ under government. For example, Johnson assigns to examples like those in (16) the structure given in (17). Note that in Johnson's analysis, μ is θ -transparent and capable of assigning Case. Verbs themselves do not have Case-assigning ability.

(17) (= Johnson's (112))

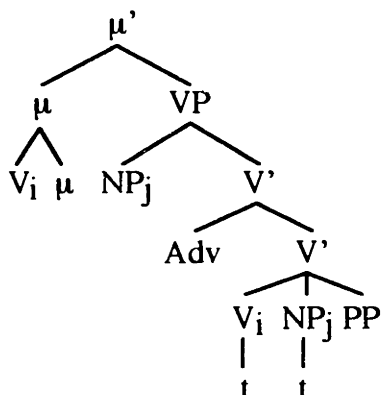

Johnson crucially assumes (i) that complements are all generated as sisters to a verb (because of the Projection Principle), (ii) the Spec of VP is empty at D-structure, reserved for an NP that will later move into this position to get Case-marked, and (iii) adverbs may adjoin to V' but not to VP. Johnson needs the third assumption to rule out the examples in (3) and (18), in which an adverb intervenes between the verb and the object NP.

- (18) a. * Bob put [vp intentionally [vp all three books on the table]]
 b. * Aaron gave secretly the ring to her.

However, Johnson's analysis cannot account for the examples in (19). (19)a will have the structure in (20) under his analysis.

(i) Mary hit John intentionally twice.

Pesetsky's (1989) analysis will assign to (i) the structure in (ii). Thus it incorrectly predicts that (i) only has the reading where *twice* has scope over *intentionally*.

(ii) Mary [[[vp hit John] intentionally] twice]

- (19) a. Chuck talked calmly to her about it.
 b. Chuck talked to her calmly about it.

(20)

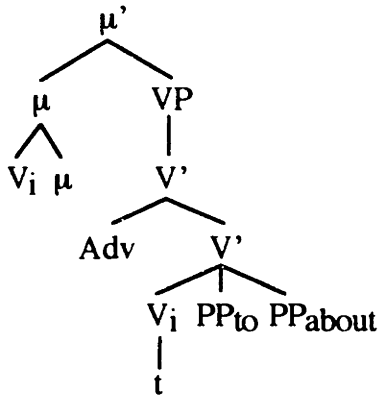

In this structure, the command relation of the two PPs are not quite correct. The first PP must be structurally higher than the second PP, as the following examples indicate.⁸

- (21) a. Joni talked to Marty_i about himself_j.
 b. * Joni talked to himself_j about Marty_j.
 (22) a. Joni talked to every boy_i about his_i mother.
 b. * Joni talked to his_i mother about every boy_j.

Furthermore, Johnson's analysis cannot generate (19)b, in which an adverb occurs between the two PPs that are sisters to the verb. Note that the scope facts given in (23), due to Colin Phillips (personal communication), show that sentences such as (19) and (23) are not derived by extraposing the PPs.

- (23) a. ? John shouted intentionally twice at her about her late homework.
 b. John shouted at her intentionally twice about her late homework.
 c. John shouted at her about her late homework intentionally twice.
 a,b: intentionally > twice ---> [intentionally [twice ...]]
 c: twice > intentionally ---> [[... intentionally] twice]

⁸ See Pesetsky (1994) for an alternative interpretation of the data.

Johnson's analysis therefore cannot be maintained as it is.

Finally, let us consider how a Larsonian (cf. Larson 1988; 1990) VP-shell type structure might account for the relevant facts, without adopting AGRoP. The sentences in (16), which are problematic for Pesetsky (1989), can be derived by assuming that adverbs may adjoin to V', as shown in (24).⁹

(24) a. Aaron gave the ring secretly to her. (= (16)b)

b.

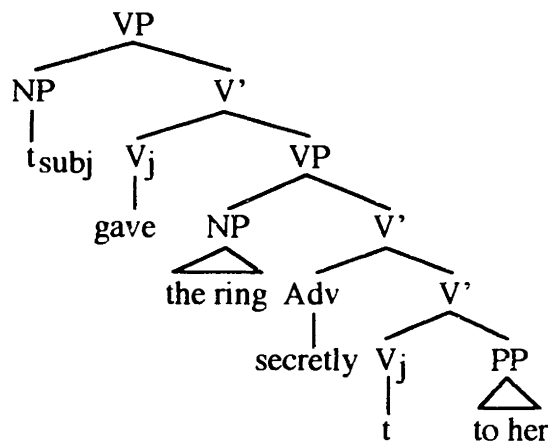

The ungrammatical examples in (18) will be ruled out under the assumption that adverbs may not adjoin to VP. Thus, the VP-shell approach can accommodate (16) and (18) by making the two assumptions in (25).

(25) a. Adverbs may adjoin to V'.

b. Adverbs may not adjoin to VP.

An advantage of the VP-shell approach over Pesetsky's and Johnson's analyses is that it correctly captures hierarchical asymmetries among complements.¹⁰ For example, under

⁹ This analysis, though assuming Larsonian VP-recursion (hence called Larsonian), is not Larson's (1988, 1990). At this point, it is not clear to me how the relevant facts discussed here might be accounted for in Larson's analysis, in which VP-adverbs are generated as complements of some V in a series of recursive VPs.

¹⁰ See Pesetsky (1994) for a critical evaluation of Larsonian VP-shell type analyses.

this analysis, the relevant part of (21)a has the following structure at the point of SPELL-OUT.

- (26) a. Joni talked to Marty_j about himself_j. (= (21)a)
 b.

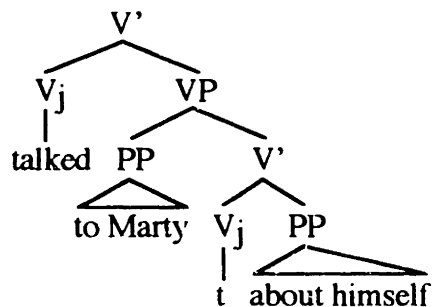

The major problem with this approach is that neither of the two assumptions in (25) can be maintained. First, (25)a wrongly allows (27)a, assigning to it the structure (27)b or (27)c (cf. Larson's 1988 (26)).

- (27) a. * Aaron gave Joni secretly the ring.
 b. Aaron gave_v [VP Joni_j [V' [V' secretly [V' t_v t_i]] the ring]]
 c. Aaron gave_v [VP Jonii [V' secretly [V' [V' t_v t_i] the ring]]]

Second, given a structure like (26)b, sentences such as (19)a and (23)a involve adverbs adjoined to VP. Thus, (25)b predicts, contrary to the fact, that they are ungrammatical. It seems then that though better than Pesetsky's and Johnson's analyses in certain respects, the VP-shell approach still falls short of the mark.

Since all previous studies fail to solve the problems of case adjacency, I would like to start anew.

2. Deriving the Adjacency Condition

In the previous subsection, I have critically reviewed three analyses of the Case adjacency effects in English. Pesetsky (1989) convincingly demonstrates the necessity of postulating main verb movement in overt syntax. Johnson (1991), drawing on Stowell (1981) and Pesetsky (1989), argues that there is a specific position reserved for an NP around the VP boundary, and that object NPs move to this position for Case-theoretic reasons. Larson's (1988) VP-shell provides the right kind of hierarchical structures

internal to VPs. I believe that the insights of these analyses are basically right. What is not right, it seems to me, is that they all assume an impoverished theory of clause architecture and a government-based approach to Case-assignment (for good historical reasons). The Split Infl Hypothesis (Pollock 1989; Chomsky 1991) and the Agreement-based Case Theory (Chomsky and Lasnik 1993; Chomsky 1993b; cf. also Fukui and Speas 1986) now give us a better framework in which the problematic aspects of their analyses can be neatly resolved.

I would like to suggest that in English, object DPs overtly raise to the Spec of AGRo.¹¹ Thus, (28)a has the structure in (28)b at the point of SPELL-OUT. At this point I abstract away from the nature of the phrase above AGRoP (i.e. XP), and will return to a discussion of this in Chapter 5. I also suppress the subject and its traces until then. Tense, modals, Neg, aspectual *have* and *be*, etc. are all higher than XP.

(28) a. Aaron gave the ring secretly to her. (= (16)b)

b.

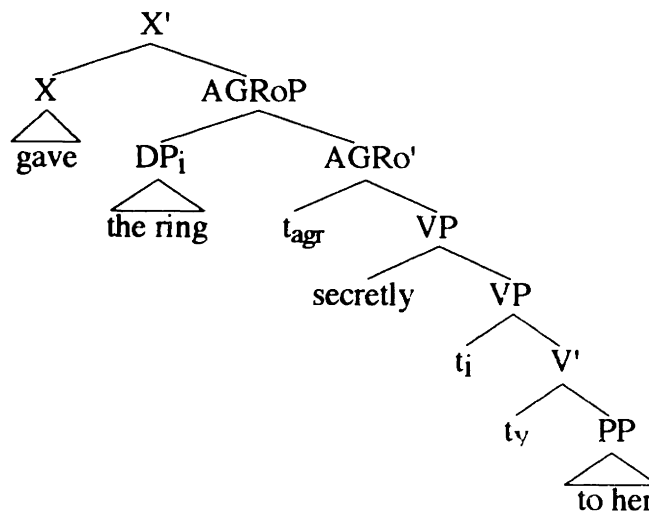

¹¹ Chomsky's (1991; 1993b) analysis, in which the object DP raises to the Spec of AGRo in LF, faces the same problems as the Larsonian analysis discussed in the previous subsection, because as far as VP-internal structures are concerned, they assume basically the same ones at the point of SPELL-OUT.

From a natural assumption that VP-adverbs must adjoin to verbal projections such as VP and V', it follows that they cannot adjoin to projections of AGR. The structure in (29) is illegitimate for this reason.¹²

¹² It has occasionally been suggested that adverbs must be licensed by a category with lexical semantic content which is compatible with their semantic content (cf. Sportiche 1988; Zubizarreta 1982; Travis 1988, etc.). Assuming that for an adverb to be licensed, it must adjoin to a projection of its licenser, VP-adverbs adjoin to a verbal projection such as VP (see (28)b). As AGR is a "pure" functional category, it has no lexical semantic content. Thus adverbs may not adjoin to projections of AGR such as AGRoP. For this reason, adverbs may not adjoin to AGRsP either, as the following examples indicate:

- (i) a. * Will [AGR_{sP} tomorrow [AGR_{sP} Sue speak French]]?
 b. * It's possible [CP for [AGR_{sP} tomorrow [AGR_{sP} Sue to speak French]]]

According to Culicover (1991), matrix clauses lack the projections of C, and the highest category of a matrix clause is PolP (Polarity Phrase). *Will* in (i)a is, therefore, adjoined to Pol⁰, as shown in (ii).

- (ii) *[PolP [Pol Will_i Pol] [AGR_{sP} tomorrow [AGR_{sP} Sue t_i speak French]]]

The head Pol may have several different semantic and syntactic values ranging over Neg, Wh, So, Rel, etc. (see Culicover 1991 for details and discussion, cf. also Chapter 6). Certain adverbs may adjoin to PolP, as exemplified below:

- (iii) a. [PolP Tomorrow [PolP will [AGR_{sP} Sue speak French]]]?
 b. John said [CP that [PolP tomorrow [PolP [AGR_{sP} Sue will speak French]]]]
 c. I wonder [CP whether [PolP tomorrow [PolP [AGR_{sP} Sue will speak French]]]] (Kyle Johnson, personal communication)
 d. This is the tree [CP which_i [PolP just yesterday [PolP [AGR_{sP} I had tried to dig up t_i with my shovel]]]] (Culicover 1991)

Since PolP does not occur in infinitival clauses, *tomorrow* in (i)b cannot be adjoined to PolP.

- (29) a. * Aaron gave secretly the ring to her. (= (18)b)
 b. *

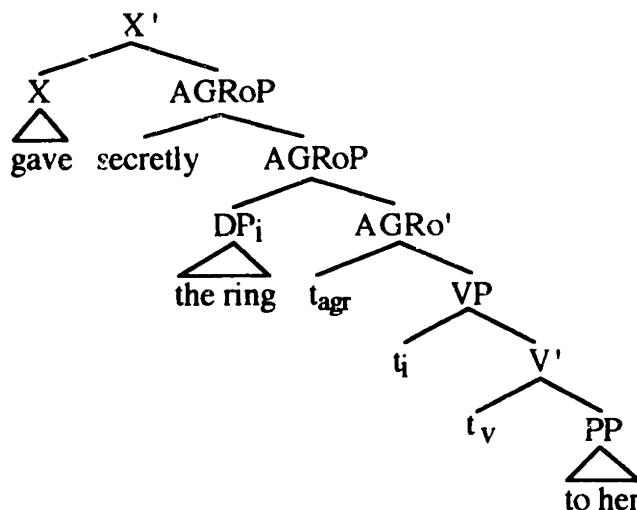

This analysis, unlike the three analyses discussed in the previous section, can readily accommodate the sentences in (19), by assigning to them the following structures.¹³

- (30) a. Chuck talked [vp calmly [vp to her [v' tv about it]]]
 b. Chuck talked [vp to her [v' calmly [v' tv about it]]]

Two questions arise at this point: (i) what is the motivation for the overt raising of the object?, and (ii) what is the driving force of the overt movement of the main verb?

¹³ The proposed analysis can also account for the ambiguity of (i), which is problematic for analyses like Pesetsky's (1989) that do not assume overt object raising (see note 7).

- (i) Mary hit John intentionally twice.

Intentionally has scope over *twice* if (i) has the structure in (ii)a or (ii)b, whereas *twice* takes wide scope when it is assigned the structure (iii)a or (iii)b.

- (ii) intentionally > twice
 a. ... [AGRoP John_i AGR [vp intentionally [twice [t_i t_v]]]]
 b. ... [AGRoP John_i AGR [vp intentionally [[t_i t_v] twice]]]
- (iii) twice > intentionally
 a. ... [AGRoP John_i AGR [vp [[t_i t_v] intentionally] twice]]
 b. ... [AGRoP John_i AGR [vp [intentionally [t_i t_v]] twice]]]

The first question consists of two parts: "what forces *raising*?" and "what forces *overt raising*?" As for the former, we assume, with Chomsky (1993b), that the object NP raises in order to have its Case/Agreement features checked (cf. also Chomsky 1991; Chomsky and Lasnik 1993). Non-DPs do not raise to the Spec of AGR_o, since they do not participate in Case/Agreement checking. Before answering the second part of question (i), we review Chomsky's (1993b) analysis of Nominative Case checking. According to Chomsky (1993), subjects raise to the Spec of AGRs overtly in languages like English, whereas such raising takes place at LF in languages like Irish (cf. Koopman and Sportiche 1991).¹⁴ Chomsky attributes this difference to the difference in the "strength" of the NP-feature of Tense (the Nominative Case feature). In English, the NP-feature of Tense is morphologically strong. Strong features are assumed to be visible but uninterpretable in PF.¹⁵ Thus, they must be checked off in the derivation by SPELL-OUT. Weak features need not be checked in overt syntax as they are invisible in PF. Since the NP-feature of Tense in English is strong, it has to be checked before SPELL-OUT, otherwise the derivation will crash at PF. This checking is done through Spec-head agreement mediated by AGR, by adjoining Tense to AGRs, and moving the subject NP into the Spec of AGRs. This is illustrated in (31). [NP-FEATURE] indicates a strong NP-feature.

- (31) a. John laughed.
 b.

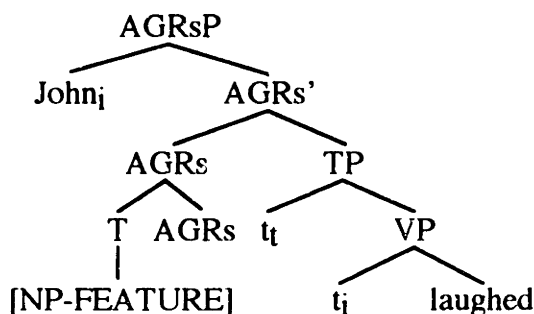

¹⁴ Irish is cited here for purely expository purposes. I am not committed to the analysis that the subject in Irish remains at the original position, at the point of SPELL-OUT. In fact, it is argued in Bobaljik and Carnie (1992) that in Irish the subject moves out of the VP in overt syntax.

¹⁵ Chomsky (1994) presents a different reason why strong features must be checked in overt syntax. The choice between the two alternatives is immaterial for our discussions below.

In Chomsky (1993b), the strong NP-feature of T is presumed to be the locus of "the extended part" of the Extended Projection Principle of Chomsky (1982:10) (cf. also Fukui 1986). In Irish, the NP-feature of Tense is weak, thus subjects need not, hence must not (for an economy reason: Procrastinate), raise in overt syntax.

Returning to objects, I suggest that the Case-features of DPs are strong in English. Hence, the object DP must move to the Spec of AGRo in order for its Case-feature to be checked off before SPELL-OUT, as shown in (32).

- (32) a. Jan ate lemons.
b.

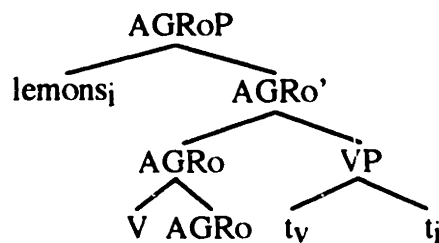

As for the second question (i.e., what is the driving force of the overt main verb movement to X?), I simply assume that X has a strong V-feature, which must be checked against a feature of a lexical verb prior to SPELL-OUT (this amounts to saying that X is a bound morpheme). When V raises to X, it first adjoins to AGRo (cf. (32)b), then the [AGRo V AGRo] complex raises to the position adjoined to X.

3. The ECM Construction

Chomsky & Lasnik (1993) suggest that the subject of an infinitival complement of *believe*-type verbs (*believe*, *prove*, *declare*, etc.) raises to the specifier position of the matrix AGRo at LF, as shown in (33). This analysis captures Postal's (1974) insight of Subject-to-Object Raising in a manner compatible with current theoretical assumptions.¹⁶

- (33) [AGRoP DP_i [AGRo' [VP ... [IP t_i ...]]]]

¹⁶ In Postal's original analysis, the ECM subject is raised to the position in which the canonical object is base-generated. This violates the θ -criterion and/or the projection principle of Chomsky (1981). Under the new analysis proposed in Chomsky & Lasnik (1993), this problem does not arise because the landing site of the ECM subject is not a θ -position.

As regular objects raise to the Spec of AGRo for CASE (Case and Agreement) reasons, ECM subjects raise to the Spec of the matrix AGRo to have their Case and ϕ -features checked against the NP-features of the AGRo and the verb of the matrix clause.

If we are correct in suggesting that the Case feature of a DP is strong in English, Raising of ECM subjects has to take place in overt syntax. Thus, (34)a has the partial structure (34)b at the point of SPELL-OUT.

(34) a. Chad believes Chuck to be a genius.

b.

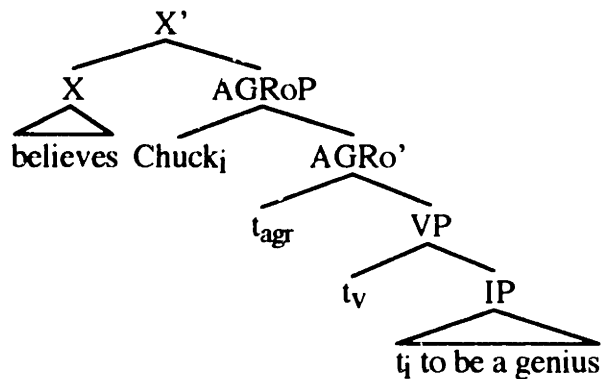

The analysis that the ECM subject raises to the Spec of the matrix AGRo receives an initial support from the following examples by Lasnik & Saito (1991). In (35) and (36), the (a) examples illustrate that the subject of an embedded tensed clause does not c-command matrix adjuncts, whereas the (b) cases demonstrate that the object of a clause c-commands certain types of adjuncts of that clause. The (c) sentences show that the subject of an embedded infinitival clause behaves on a par with the matrix object, rather than the subject of an embedded tensed clause.¹⁷

(35) a. ?* The DA proved [that the defendants were guilty] during each other's trials.

b. ? The DA accused the defendants during each other's trials.

c. ? The DA proved [the defendants to be guilty] during each other's trials.

(36) a. ?* The DA proved [that none of the defendants were guilty] during any of the trials.

¹⁷ The judgments are not as clear as we might expect. But there are reasons for the fuzziness, as discussed in Branigan (1992: Chapter 3).

- b. The DA accused none of the defendants during any of the trials.
- c. ? The DA proved [none of the defendants to be guilty] during any of the trials.

(Lasnik and Saito 1991)

This indicates that the ECM subject may raise to a matrix position from which it can c-command the matrix adjuncts. The examples in (37) and (38) show that the raising is obligatory.

- (37) a. Joan believes (that) he_i is a genius even more fervently than Bob's_j mother does.
- b. ?* Joan believes him_i even more fervently than Bob's_j mother does.
- c. ?* Joan believes him_i to be a genius even more fervently than Bob's_j mother does.

(Lasnik and Saito 1991)

- (38) a. ?* The king declared him to be an outlaw even more eagerly than Marcel's own squire had.
- b. The king declared that he was an outlaw even more eagerly than Marcel's own squire had.

(Branigan 1992:63)

Under the assumption that the ECM subject *him* must raise to a matrix position, (37)c and (38)a will be ruled out by Condition C, on a par with (37)b. On the other hand, if the ECM subject may stay within the embedded clause throughout the derivation, they should be perfectly grammatical, as (37)a and (38)b.

If the level of representation relevant to Condition C and the licensing of anaphors and negative polarity items is S-structure, as argued by many researchers (Chomsky 1981, Barss 1986, Saito 1986, 1989, Lasnik & Saito 1991, 1992, to name a few), the above set of examples suffice to show that Raising takes place prior to SPELL-GUT. On the other hand, if these conditions apply at LF as suggested in Chomsky (1993), the examples only show that the ECM subject occupies the Spec of the matrix AGRo at LF.¹⁸ Thus, to prove

¹⁸ See Miyagawa (1993) for further evidence that the ECM subject undergoes movement into the matrix clause at some point of derivation.

that Raising really takes place before SPELL-OUT, we need to find other types of evidence.

I present three examples of such evidence. First, as originally noted in Postal (1974), the ECM subject may occur to the left of certain matrix elements:¹⁹

- (39) a. I've believed John_i for a long time now [t_i to be a liar] (Kayne 1985a)
 b. I have found Bob_i recently [t_i to be morose] (Postal 1974)
 c. We proved Smith_i to the authorities [t_i to be the thief] (Bowers 1993)
 d. ? I proved him_i conclusively [t_i to be a liar] (Authier 1991)
 e. I suspect him_i strongly [t_i to be a liar] (Authier 1991)

Since matrix adverbials do not occur in embedded clauses, these examples strongly indicate that the ECM subject occupies a matrix position at the point of SPELL-OUT (cf. Kayne 1985a; Authier 1991; Johnson 1991, etc.). The ungrammaticality of (40) suggests that the over_i raising is to a position higher than the matrix VP, as predicted by our "Raising to the Spec of AGR_o" analysis.

- (40) a. * I've believed for a long time now John to be a liar
 b. * I have found recently Bob to be morose
 c. * We proved to the authorities Smith to be the thief
 d. * I proved conclusively him to be a liar
 e. * I suspect strongly him to be a liar

¹⁹ For many speakers of English, examples like those in (39) are deviant. However, there are also many speakers who find these sentences acceptable. Although it is not clear to me at this point exactly what is responsible for this idiolectal split (or variation), a possibility is that the ECM embedded clause itself needs to move to the Spec of AGR_o for some CASE-related reasons, and the ECM subject raises to the Spec of another AGR, as shown in (i).

(i) ... [AGR_{io}P DP_i AGR_{io} [AGR_oP [ECM clause ... t_i ...] [VP VP-adv. [VP ... t_j ...]]]]

To obtain the word order in (39), the ECM clause has to be extraposed. If so, it might be the case that the examples in question are somewhat marked for some speakers because the extraposition of the ECM clause is marked for those speakers.

This is so because, if the landing site of the ECM subject were within the matrix VP, adverbs adjoined to the VP should be able to occur between the matrix verb adjoined to X and the ECM subject.

The second type of evidence has to do with the position of a particle in the verb-particle construction. Normally the particle of a particle verb of the matrix clause cannot occur in the embedded clause as illustrated by (41)b. However, in (41)d, the ECM subject precedes the particle, suggesting that it is in the matrix domain at the point of SPELL-OUT. The grammaticality of (41)d thus, lends support to the overt raising analysis (cf. Kayne 1985a).²⁰

- (41) a. They're trying to make out that John is a liar
 b. * They're trying to make that John out is a liar
 c. ? They're trying to make out John to be a liar
 d. They're trying to make John out to be a liar

Third, assuming Fukui and Speas' (1986) taxonomy of functional categories summarized in (42), Lobeck (1990) and Saito & Murasugi (1990) argue that only a constituent that is the complement of an agreement-inducing functional head may be deleted.

(42) Functional Categories:

	Agreement-inducing	Non-agreement-inducing
I (=T)	I [+tense]	<i>to</i>
D	's	<i>a(n), the</i>
C	[+wh] Comp	<i>that, whether, if</i>

Thus, the (a) examples in (43) and (44) with agreement inducing heads are grammatical, whereas the (b) examples with non-agreement-inducing heads are ungrammatical.

²⁰ See Koizumi (1993c) for an analysis of the word order alternation between (41)c and (41)d. Cf. also Johnson (1991).

- (43) a. We want to invite someone, but we don't know
 [CP who [C'[C +wh] [IP e]]]
 b. * We thought Sue wanted to be invited, but we weren't sure
 [C'[C whether/if] [[IP e]]
 (Lobeck 1990)
- (44) a. Lincoln's portrait didn't please me as much as [DP Wilson [D 's] [NP e]]
 b. * I read about that person, and now, I want to see [D[D the] [NP e]]
 (Saito and Murasugi 1990)

Following these authors, Martin (1992) claims that the grammaticality of (45) shows that *to* in Control infinitives agrees with PRO in its specifier position.

- (45) a. John wasn't sure he'd win the race, but he tried [PRO to [VP e]]
 b. John convinced Bill to come to the party, and Sarah convinced Mary
 [PRO to [VP e]]

On the other hand, the ungrammatical examples in (46) suggest that *to* in Raising infinitives, unlike *to* in Control infinitives, does not agree with its specifier.²¹

- (46) a. ?* Mary claims to not like baseball, but she appears to [VP e]
 b. * John considers Mary to be clever, and Mike considers Sally to [VP e]

In other words, T(*to*) in Control infinitives assigns Null Case in the sense of Chomsky & Lasnik (1993), while T(*to*) in Raising infinitives does not have Null Case.

A question then arises as to what forces the ECM subject to move from its base-position to the pre-*to* position in overt syntax.

- (47) a. John considers Mary_i to be t_i clever
 b. * John considers to be Mary clever
 c. John believes Bill_i to be loved t_i by Mary
 d. * John believes to be loved Bill by Mary

²¹ There are apparent counter examples to this generalization. See Martin (1992) for discussion.

It cannot be the strong NP-feature (Null Case) of *to*, since *to* in the Raising infinitive does not have such feature, as we have just seen. Here, we are faced with a paradox: *to* does not have features to attract the ECM subject, yet it appears to attract it to the pre-*to* position. Our overt raising analysis can provide a natural solution for this problem. As *Mary* in (48)a overtly raises to the Spec of AGRs, to have its strong Case-feature to be checked off, *Mary* in (48)b overtly raises to the Spec of AGRo for Case reasons.

- (48) a. [AGRsP Mary_i [TP appears [t_i to be t_i clever]]]
 b. John considers [AGRoP Mary_i [VP [t_i to be t_i clever]]]

The contrast between (45) and (46), thus, constitutes a rather surprising piece of evidence for the proposed analysis.

In summary, I have shown that ECM subjects, like regular objects, raise to the Spec of AGRo prior to SPELL-OUT.²²

4. The Double Object Construction

We have seen that the object and the ECM subject overtly raise to the Spec of AGRo. Given this, two analyses are envisaged of the Double Object Construction (DOC) such as (49). They are shown in (50).

²² Ura (1993) independently reached a similar conclusion.

Citing the following pair of examples, Branigan (1992:48) argues that there must be some difference between the surface position of regular objects and the surface position of ECM subjects, hence the overt raising analysis of ECM subjects cannot be maintained (this objection to Raising to object is originally due to Chomsky 1973).

- (i) a. Which one of us do you believe the agent has a picture of?
 b. ?? Which one of us do you believe a picture of to be on the agent's wall?

However, there are several conceivable reasons why (ib) is somewhat deviant. For example, it violates Kuno's (1973) Clause-Nonfinal Incomplete Constituent Constraint. Koizumi (1993b) argues that what is responsible for the contrast in (i) is that in (ia) the picture noun is in the minimal domain of its θ -role assigner, whereas in (ib) it is outside the minimal domain of its θ -role assigner. Suppose that a domain X is transparent with respect to extraction if i) there is a head H that selects X, and ii) X is in the minimal domain of H; it is opaque otherwise (a minimalist version of Huang's 1982 CED). This condition accounts for the familiar subject island condition and adjunct island condition as well as the ban on extraction out of the ECM subject.

- (49) a. John gave Bill a book.
 b. Amber told Ben the story.
 c. Norman cooked Jean sushi.
- (50) i) John gave [AGRoP Bill_i [VP ... t_i ... a book ...]]
 ii) John gave [AGRioP Bill_i [AGRoP a book_j [VP ... t_i ... t_j ...]]]

There are at least two reasons to prefer (50)ii to (50)i. First, the Theme object in the DOC receives the same Case with the regular single direct object (e.g. accusative) cross-linguistically, but the same is not true for the Goal object: While in many languages, the Goal argument is marked with accusative; there are also many languages in which the Goal DP is marked with other cases such as dative (e.g. Albanian, Icelandic, etc.) Thus, if one of the two objects in the DOC is Case-checked in the same manner as the single direct object (i.e. by raising to the Spec of AGRo), it must be the Theme object rather than the Goal object.

Second, if the Goal object alone has moved out of the VP as in (50)i, it should be possible for a VP-adverb to occur between the Goal object and the Theme object, adjoining to the VP as in (51). This is not the case, however. As shown in (52) and (53), VP-adverbs must follow the Theme object.

- (51) [AGRoP John_i t_{agr} [VP secretly [VP t_i t_v the book]]]
- (52) a. ?* Mary gave John secretly the book (on Friday).
 b. ?* Amber told Ben quietly the story (in the living room).
- (53) a. Mary gave John the book secretly (on Friday).
 b. Amber told Ben the story quietly (in the living room).

Under the analysis (50)ii, both objects overtly raise across the VP boundary, where VP-adverbs such as *secretly* occur:

- (54) [AGRioP John_i t_{agr} [AGRoP the book_j t_{agr} [VP secretly [VP t_i t_v t_j]]]]

The contrast between (52) and (53) is thus expected in this analysis.

It seems then reasonable to conclude that both objects in the DOC overtly move out of the VP, as shown in (55).²³

(55)

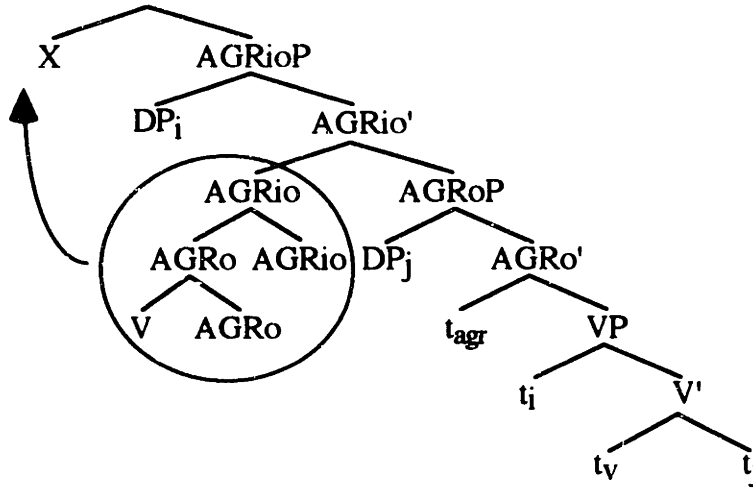

In Chomsky's (1993b) Case theory, the Case-feature of the DP in the Spec of AGRo can be checked against the Case-feature of the verb because the Spec of AGRo is in the checking domain of the verb once the verb raises to AGRo. Under this assumption, the Case-feature of the DP in the Spec of AGRio in (55) cannot be checked against a Case-feature of the verb, for the Spec of AGRio is not in the checking domain of the verb even if the complex $[AGRo V AGRo]$ raises to AGRio. Thus, if the structure (55) is indeed correct, the Case theory needs to be reconsidered.

²³ I assume the following thematic hierarchy (cf. Larson 1988; Grimshaw 1991; and Pesetsky 1994, among others).

- (i) Agent > Affected Goal > Theme > Unaffected Goal

The first DP object in the double object construction such as (iia) receives Affected Goal role, whereas the PP in the dative construction such as (iib) receives Unaffected Goal role.

- (ii) a. John gave Bill a watch.
 b. John gave a watch to Bill.

Given Chomsky's (1993b) locality condition, the proposed structure of the DOC makes correct predictions about the passivizability of the first object, and the unpassivizability of the second object. See Ura (1994b) for details.

I suggest that the Case-feature of the DP in the Spec of AGRo can be checked against the Case-feature of the verb adjoined to AGRo *not* because the DP is in the checking domain of the verb, *but* because the DP and the verb are both in the checking domain of AGRo. That is, I propose modifying Chomsky's Case theory along the following lines. In the structure like (56) for example, the Case-feature of the DP and the Case-feature of V are both copied onto AGRo under the structural condition that the DP and the verb are each in the checking domain of AGRo. If the Case-types of the two Case-features match (e.g. both are Accusative), the Case-checking process is successful, and we may informally say that the DP is Case-licensed. If the Case-type of the DP do not match the Case-type of the verb, the Case-checking process fails, leaving the DP yet to be Case-licensed. Case-checking between the subject DP in the Spec of AGRs and T adjoined to AGRs is performed in the same fashion.

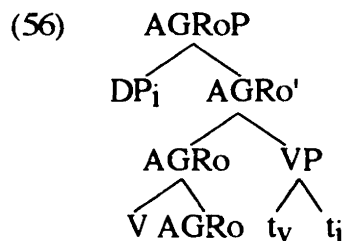

An advantage of this revision is that the question never arises as to why the DP in the Spec of V can never be Case-licensed by V despite that it is in the checking domain of the Case-licensing verb. This is so because under our version of Case theory, Case-checking always involves feature-copying onto AGR, thus it never takes place between a DP and a verb, without AGR mediating the two.

Another positive consequence of this modification is that the DP in the Spec of AGRio in the structure like (55) can now be Case-licensed in the following manner: The Case-feature of DP is copied onto AGRio. If the verb has a second Case-feature in addition to the first one copied onto AGRo, that second Case-feature is copied onto AGRio. This is possible because the verb is in the checking domain of AGRio once the [AGRo V AGRo] complex adjoins to AGRio. Now if the Case-types of the two Case-features copied onto AGRio are the same type, the Case-checking is successful (i.e., the DP in the Spec of AGRio is Case-licensed).

5. Some Differences between English and French

Consider the following French examples.

- (57) a. * Les enfants probablement ont vu ce film.
the children probably have seen this movie
- b. Les enfants ont probablement vu ce film.
the children have probably seen this movie

Under the account of the adverbial distribution proposed above, (57)a is ungrammatical because it contains an adverb *probablement* adjoining to a projection of AGR, i.e. AGRs', which does not have ability to license adverbs (see (58)a) (Recall that, in the proposed analysis, functional categories without lexical semantic content cannot host adverbs). In (57)b, the adverb is adjoined either to TP as in (58)b or to the VP projected from *ont* ('avoir 'have') as in (58)c.

- (58) a. * [AGRsP les enfants [AGRs' probablement [AGRs' ont [TP ...
the children probably have
- b. [AGRsP les enfants [AGRs' ont [TP probablement [TP ...
the children have probably
- c. [AGRsP les enfants [AGRs' ont [TP ... [VP probablement [VP ...
the children have probably

If *have* in (59)a is adjoined to AGRs like *ont* in (57)a, (59)a should be ungrammatical on a par with (57)a.

- (59) a. The children probably have seen this movie.
b. The children have probably seen this movie.

Thus, the acceptability of (59)a suggests that in English the highest auxiliary does not raise to AGRs in overt syntax (unless Subject-Aux Inversion takes place). If auxiliaries are invisible in LF as assumed in Chomsky (1993b), *have* in (59) must raise to at least as high as T in overt syntax in order to have its Tense-feature etc. checked, which in turn implies

that in English T does not raise to AGRs in overt syntax. (59)a thus has a structure like (60) at the point of SPELL-OUT.²⁴

(60) [AGRsP the children AGRs [TP probably [TP [T have_i T] [VP t_i ...

This analysis receives support from the facts about quantifier floating. Assuming Sportiche's (1988) analysis of "quantifier stranding," floating quantifiers are associated with an NP-trace in a Spec position as in "[YP [tous t] [Y'...]]".²⁵ Given this, the structures in (58) and (60) correctly predict the contrast in grammaticality between French (61)a and English (61)b, which was problematic in Sportiche's original analysis as it assumes *avoir* and *have* are both in the Infl position.

- (61) a. * Les enfants tous ont vu ce film. (Sportiche 1988:427)
 the children all have seen this film
 b. The children all have seen this film.

English (60) has a Spec position between the subject and *have* (i.e. [Spec, TP]), in which *all* can be stranded, whereas French (58) does not have such position between the subject and *ont*.

We have observed that the V-features of T and AGR are weak in English while they are strong in French. Another difference between English and French is that while the

²⁴ If T indeed does not raise to AGRs in overt syntax, the overt raising of the subject to the Spec of AGRs cannot be attributed to the strong NP-feature of T any more. Thus the extended part of the Extended Projection Principle of Chomsky (1982) must be derived from something else. See Harley (1994) for a suggestion. Under our analysis, the subject DP in English overtly raises to the Spec of AGRs because of the strong Case feature of the DP. The Case feature of the subject DP becomes weak when it is copied onto AGRs. Whether the Case-type of the subject and that of T match is checked when T raises to AGRs in LF.

²⁵ The assumption here is that the basic word order is "[Q DP]" as in (i), and when DP precedes Q, it is a result of Q stranding, as in (ii).

- (i) [Tous les enfants]_i ont t_i vu ce film.
 all the children have seen this film
 (ii) Les enfants_i ont [tous t_i] vu ce film.
 the children have all seen this film

Case-features of DPs are strong in English as we have seen, they are weak in French. Thus, in French, objects stay within the VP, as shown in (62)a.

- (62) a. French: Pierre a [XP vu_i [AGRoP [VP t_i Marie]]]
Pierre has seen Marie
- b. English: John has [XP seen_i [AGRoP Mary_j [VP t_i t_j]]]

Since in French there is a VP node between the (untensed) main verb and the object at the point of SPELL-OUT, adverbs may intervene between them, as exemplified below:

- (63) a. Pierre a vu à peine Marie.
Pierre has seen hardly Marie
 'Pierre has hardly seen Marie'
- b. Faire souvent mal ses devoirs, c'est stupide. (Iatridou 1990)
make frequently badly poss homework that is stupid
 'To frequently do one's homework badly is stupid.'

The corresponding English examples are ungrammatical because they contain adverbs adjoined to AGRoP:

- (64) a. * John has seen hardly Mary.
 b. * It is stupid to do frequently badly one's homework.

The analysis that in French the object remains within the VP in overt syntax makes possible a simple account of the following paradigm:

(65) Passives

- a. Les livres de Jules Verne ont tous été imprimés/*imprimé
the books of have all been published
- b. Il a été imprimé/*imprimées quelques éditions de cette livre.
it has been published some editions of that book

(66) Unaccusatives

- a. Ils sont déjà partis/*parti.
they are already left

- b. Il est arrivé/*arrivés quelques philosophes.
it is arrived some philosophers

As noted by Kayne (1985b; 1989), a past participle obligatorily agrees with its surface subject when it is underlyingly an internal argument ((65)a & (66)a). This suggests that derived subjects in passives and unaccusative sentences drop by at the Spec of AGR_o on their way to the Spec of AGRs as in (67), and that in French, AGR features checked prior to SPELL-OUT will be phonetically realized (Chomsky 1991).

- (67) [AGR_{sP} NP_i ... [AGR_{oP} t_i' ... [VP ... t_i ...]]]
 ↑ _____ | ↑ _____ |

In contrast, a past participle does not have overt agreement with its internal argument, or for that matter with anything, when its surface subject is an expletive ((65)b & (66)b) or an external argument (68).

- (68) Transitives
 Jean a repeint/*repeinte la table.
Jean has repainted the table

This is naturally explained if the objects in sentences like (65)b, (66)b and (68) stay within the VP, as suggested above, and if AGR features that are not checked by SPELL-OUT will not be phonetically realized. On the other hand, if these objects are raised to the Spec of AGR_o in overt syntax, the contrast between (65)a and (66)a, on the one hand, and (65)b, (66)b, and (68), on the other, could not be naturally accounted for, since there would be no syntactic distinction between the two cases with respect to AGR_o and the object.

The features of English and French are summarized below:

(69)	Features	English	French	
	AGR NP	s/w*	weak	
	V	weak	strong	
	T NP	s/w*	strong	
	V	weak	strong	
	D(P) Case	strong	weak	(*see footnote 26)

To summarize this chapter, we have seen that, although English lacks visible/audible object-verb agreement morphology, it does have Object Agreement Phrases as characterized in Chomsky (1991; 1993b), and that structural Case in English is licensed uniformly under Spec-head agreement in overt syntax.

²⁶ It is not entirely clear at this point whether or not the NP-features of T and AGR in English are strong.

CHAPTER THREE

INVISIBLE AGR IN ZARMA

In this chapter, I discuss word order and phrase structure of Zarma, a language without visible/audible agreement morphology. Zarma is a Songhay language of the Nilo-Saharan family, spoken mostly in the western part of Niger (Tersis-Surugue 1981).¹ As we will see, the Agreement-based Case theory, coupled with other central assumptions of the minimalist framework, provides a simple and principled account of basic facts about word order of this language, which in turn constitutes supporting evidence for the presence of Agreement Phrases in languages without agreement morphology.

1. Basic Word Orders

Verbs in Zarma can be divided into two classes: those occurring with a particle-like element *na* (e.g. *kar* "hit", *nama* "bite", *guna* "look at"), and those used without *na* (e.g. *di* "see", *baa* "want/like", *zuru* "run"). I will refer to the former as "*na* verbs", and the latter as "regular verbs". The nature of *na* will be discussed shortly. In simple transitive sentences with a *na* verb, the word order is Subject-*na*-Object-Verb-Others (or "S *na* O V X"). Thus the object DP precedes the verb, as shown in (1).

- (1) a. a na hansoo kar.
 he NA the dog beat
 'He beat the dog.'
- b. * a na kar hansoo.
 he NA beat the dog

Whether they are arguments or adjuncts, non-DPs appear after the verb. In other words, they may not precede either the verb or the object DP.

¹ As far as I know, Tersis-Surgue (1981) is the only book length study of Zarma. The data used in this chapter were collected by the present author through a series of interviews with one speaker of this language in Spring 1993. I would like to thank Ken Hale and Michael Kenstowicz for giving me an opportunity to carry out this research. I am also thankful to Hubert Truckenbrodt for helpful discussions.

- (2) a. boraa na zama noo zankaa-see
the man NA a knife give the child-to
 'The man gave a knife to the child.'
- b. * boraa na zama zankaa-see noo
the man NA a knife the child-to give
- c. * boraa na zankaa-see zama noo
the man NA the child-to a knife give
- d. * boraa na zankaa-see noo zama
the man NA the child-to give a knife
- (3) a. zankaa na hansoo kar nda gooru
the child NA the dog beat with a stick
 'The child beat the dog with a stick.'
- b. * zankaa na hansoo nda gooru kar
the child NA the dog with a stick beat
- c. * zankaa na nda gooru hansoo kar
the child NA with a stick the dog beat
- d. * zankaa na nda gooru kar hansoo
the child NA with a stick beat the dog

These examples indicate that there is one position between *na* and the verb that is "reserved" for the object DP.

This is most straightforwardly accounted for if we assume that there is an AGRO_P above VP, and that the object DP moves to the Spec of AGRO_P in overt syntax. Under this analysis, relevant portion of (2)a has the structure in (4). (The subject positions will be suppressed until Chapter 5).

(4)

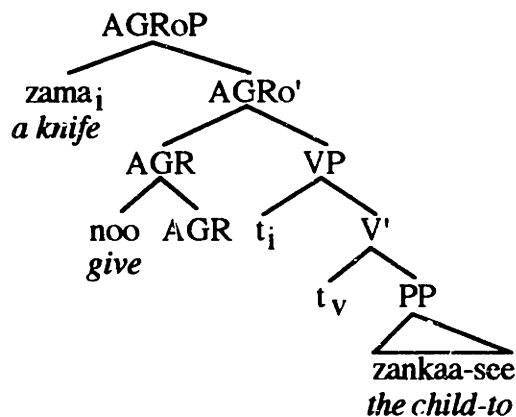

Following Chomsky (1993b), I assume that the object DP raises to the Spec of AGRo in order to have its CASE (Case and agreement) features checked. Non-DPs such as PPs do not raise to the Spec of AGRo since they do not participate in CASE checking. I suggest that the Case-features of DPs are strong in Zarma, as in English. Hence, the object DP must move to the Spec of AGRo in order to have its Case-feature checked before SPELL-OUT. Hence the structure in (4).

We have seen that sentences with *na* verbs have the "S *na* O V X" word order, and that this is readily accounted for by postulating AGRoP and strong Case-features of DPs. The basic word order of sentences with a regular verb is "S V O X". This is illustrated in (5) and (6).

(5) a. a di hansoo
he see the dog
'He saw the dog.'

b. * a hansoo di
he the dog see

(6) a. zankaa kande hwaari fu
the child bring food to the house
'The child brought food to the house.'

b. * zankaa kande fu hwaari
the child bring to the house food

c. * zankaa fu kande hwaari
the child to the house bring food

- (7) a. ay mana baa [kang hansoo na zankaa nama]
I not want that the dog NA the child bite
 'I regret that the dog bit the child.'
- b. * ay mana [kang hansoo na zankaa nama] baa
I not that the dog NA the child bite want
- c. * ay [kang hansoo na zankaa nama] mana baa
I that the dog NA the child bite not want

It does not take too long before we notice that the "S V O X" word order can be obtained if the V moves from the post O position to the position of *na* in the "S *na* O V X", as shown in (8).

- (8) a. S *na* O V X
 b. S V_i O t_i X
 ↑ _____

Under the current assumptions, (8) indicates that AGRoP is dominated by a phrase headed by *na* in (8)a, and V adjoins to the head of this phrase in (8)b. More precisely, the two kinds of sentences seem to have the following structures at the point of SPELL-OUT.

- (9) A sentence with a *na* verb
- a. a na hansoo kar. (= (1)a)
he NA the dog beat
 'He beat the dog.'

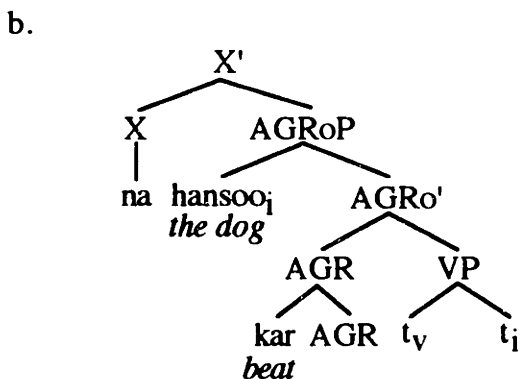

(10) A sentence with a regular verb

- a. a di hansoo (=5)a
he see the dog
 'He saw the dog.'

b.

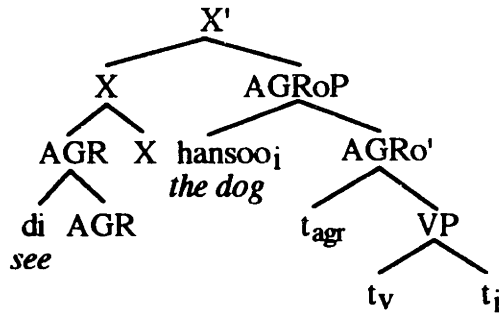

The proposed analysis accounts not only for the order of the verb and the object DP, but also for the order of the verb/the object DP and non-DPs. Since the verb and the object DP raise, and since non-DPs such as a PP and a CP do not, non-DPs necessarily follow the verb and the object DP at the point of SPELL-OUT.

Two questions arise: (i) what is the X in these structures?, and (ii) what forces the movement of the V-AGR amalgam to X in the case of regular verbs. The first question was raised in regard to English in the previous chapter. As stated there, we defer the discussion of it until Chapter 5. As for the second question, we assume that the regular verbs are morphologically dependent (affix), hence they must attach to morphologically independent (stem-like) X before the derivation branches off to PF. The *na* verbs are morphologically independent, thus they need not (hence must not) overtly raise to X.

Tense/aspectual particles such as *ga* (irrealis: IR) and *goo* (progressive: PR) occur between the subject and *na* in sentences with a *na* verb (the sequence of *ga na* is normally contracted as *gan*), and they occur between the subject and the verb in sentences with a regular verb.

- (11) a. Zankaa ga na (/ gan) hansoo kar.
the child IR NA the dog beat
 'The child will beat the dog.'

- b. ay ga di hansu
he IR see a dog
 'He will see a dog.'

This means that Tense/aspectual phrases are structurally higher than the phrase we have been referring to as XP.

2. Adverb Placement

This section discusses the distribution of adverbs, and shows that it is naturally accounted for given the clause structure motivated in the previous section by Agreement-based Case theory.

Sentential adverbs such as *bii* "yesterday" must occur either sentence initially or sentence finally.

- (12) a. bii zankaa na hansoo kar (nda guuru)
yesterday the child NA the dog beat with a stick
 'Yesterday the child beat the dog (with a stick).'
- b. * zankaa bii na hansoo kar (nda guuru)
the child yesterday NA the dog beat with a stick
- c. * zankaa na bii hansoo kar (nda guuru)
the child NA yesterday the dog beat with a stick
- d. * zankaa na hansoo bii kar (nda guuru)
the child NA the dog yesterday beat with a stick
- e. * zankaa na hansoo kar bii nda guuru
the child NA the dog beat yesterday with a stick
- f. zankaa na hansoo kar (nda guuru) bii
the child NA the dog beat with a stick yesterday
 'The child beat the dog (with a stick) yesterday.'
- (13) a. bii zankaa di hansoo
yesterday the child see the dog
 'Yesterday the child saw the dog.'
- b. * zankaa bii di hansoo
the child yesterday see the dog
- c. * zankaa di bii hansoo
the child see yesterday the dog
- d. zankaa di hansoo bii
the child see the dog yesterday
 'The child saw the dog yesterday.'

This indicates that in Zarma S-adverbs may either left-adjoin or right-adjoin to the clausal projection. Since Zarma lacks postposing operations comparable to Extraposition and/or Heavy (DP) Shift found in English, it is not possible to derive (12)e or (13)c by moving the instrumental phrase or the object DP rightward past the adverb.

VP adverbs such as *gumo* "a lot/completely" may appear either to the left or to the right of a PP. However, they may not precede the verb or the object DP, nor do they occur in the sentence initial position.

- (14) a. zankaa na hansoo kar (nda guuru) gumo.
 the child NA the dog beat with a stick a lot
 'The child beat the dog (with a stick) a lot.'
- b. zankaa na hansoo kar gumo nda guuru.
 the child NA the dog beat a lot with a stick
 'The child beat the dog a lot (with a stick).'
- c. * zankaa na hansoo gumo kar (nda guuru).
 the child NA the dog a lot beat with a stick
- d. * zankaa na gumo hansoo kar (nda guuru).
 the child NA a lot the dog beat with a stick
- e. * zankaa gumo na hansoo kar (nda guuru).
 the child a lot NA the dog beat with a stick
- f. * gumo zankaa na hansoo kar (nda guuru).
 a lot the child NA the dog beat with a stick
- (15) a. zankaa goo ga di hansoo gumo
 the child PR IR see the dog a lot
 'The child is seeing the dog a lot '
- b. * zankaa goo ga di gumo hansoo
 the child PR IR se a lot the dog
- c. * zankaa goo ga gumo di hansoo
 the child PR IR a lot see the dog
- d. * gumo zankaa goo ga di hansoo
 a lot the child PR IR see the dog

Since PPs in Zarma cannot be "right-dislocated" (cf. (12)e), the "adverb + PP" order in (14)b must be the base-generated order, rather than a derived one. Assuming that VP-

adverbs such as "completely" are adjoined to a VP, the adverb in (14)a is right-adjoined to the VP, and the adverb in (14)b is left-adjoined to the VP. The position of the adverb in (15)a is ambiguous between the two possibilities. The relevant part of the structure of (14)b is given below.

- (16) a. zankaa na hansoo kar gumo nda guuru. (=14)b)
 the child NA the dog beat a lot with a stick
 'The child beat the dog a lot with a stick.'

b.

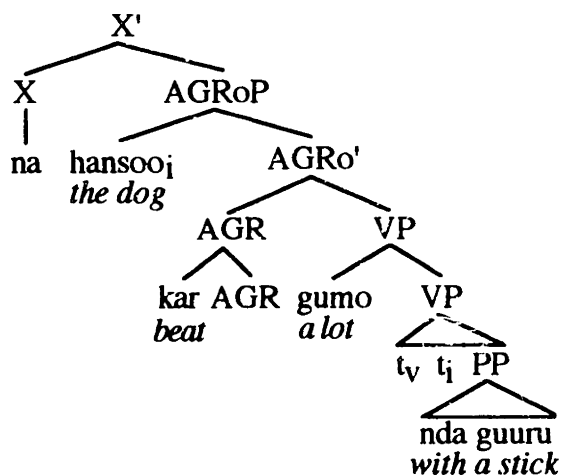

The examples in (14)c through (14)f and (15)b through (15)d are ungrammatical because they involve a VP-adverb adjoined to a category other than VP. For example, in (14)c and (15)b, the VP-adverb *gumo* adjoins to AGRo' and AGRoP, respectively, which, being projections of a semantically null "pure" functional category, do not have ability to license adverbs.

- (17) a. * zankaa na hansoo gumo kar (nda guuru). (=14)c)
 the child NA the dog a lot beat with a stick

b. *

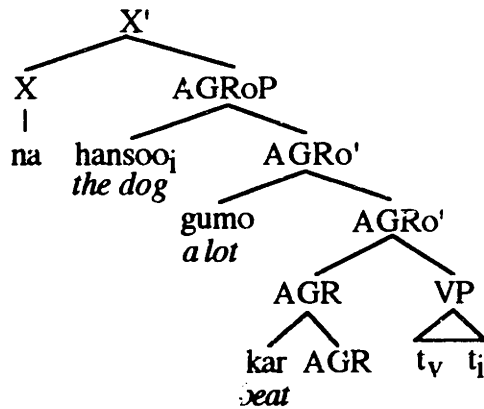

- (18) a. * zankaa goo ga di gumo hansoo (= (15)b)
the child PR IR see a lot the dog
 'The child is seeing the dog a lot.'

b. *

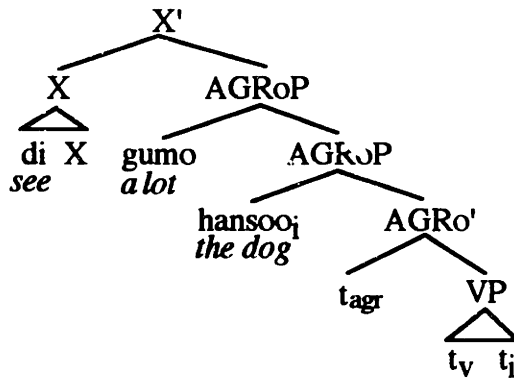

Note that this analysis effectively derives the Adjacency Condition on Case Assignment of Stowell (1981), which stipulates that the Case-assigner and Case-assignee be string-adjacent. The proposed analysis is much more general than the Adjacency Condition because it explains not only the ungrammaticality of (14)c and (15)b, which can be accounted for in terms of adjacency, but also the ungrammaticality of the other starred examples in (14) and (15), which the Adjacency Condition has nothing to say about. For example, under the present analysis, (14)d is ruled out for the same reason as (15)b, i.e., the adverb is adjoined to a projection of "pure" functional category, AGR.

- (19) a. * zankaa na gumo hansoo kar (nda guuru). (= (14)d)
the child NA a lot the dog beat with a stick
 'The child beat the dog a lot (with a stick).'

b. *

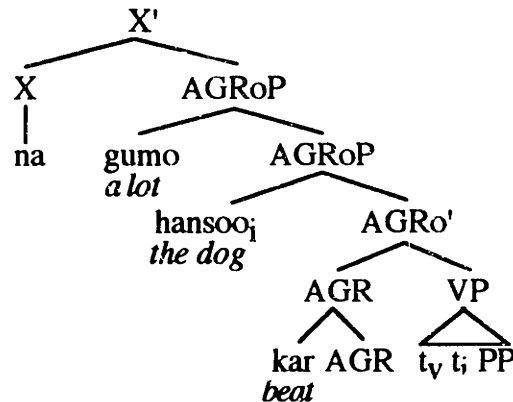

It is worth while to note that the distribution of adverbs we have just seen cannot be naturally accounted for under GB approaches such as Pesetsky's (1989) and Johnson's (1991), which we reviewed in Chapter 2. For example, if we extend Pesetsky's (1989) analysis of the Case adjacency effects in English to Zarma, the ungrammatical (14)d would have the following structure.

(20)

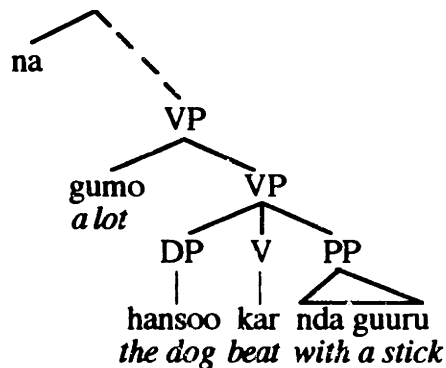

Since Pesetsky's (1989) analysis allows adverbs adjoined to VP (or V'), there should be nothing wrong with this structure. Thus, it incorrectly predicts that (14)d should be grammatical. Johnson (1991), on the other hand, can rule this example out by assuming that *na* is the head of μ , and the object *hansoo* has moved to the Spec of VP (recall that adverbs cannot adjoin to VP in his analysis). However, his analysis wrongly rules (14)c in, assigning to it the following structure, in which the adverb is adjoined to V', an option allowed in his analysis.

- (21) a. * zankaa na hansoo gumo kar (nda guuru). (=14)c
the child NA the dog a lot beat with a stick

b.

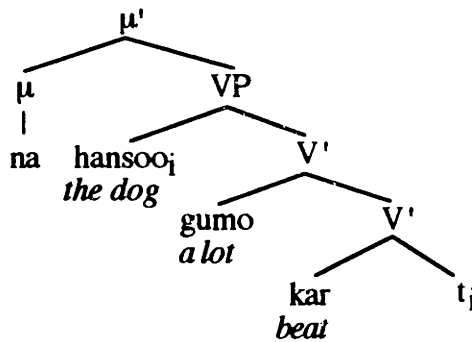

In conclusion, the phrase structure with AGRoP motivated by Agreement-based Case theory makes available a principled account of the distribution of adverbs that is empirically more adequate than previous proposals that assume Government-based Case theory.

3. The Double Object Construction

I have argued that the object DP of a transitive verb such as *kar* "hit" overtly raises to the Spec of AGRo, which is driven by the strong Case-feature of the DP. Given this, two possible analyses are envisaged of the double object construction such as (22). These are given in (23).

- (22) boraa na zankaa noo zaamay
the man NA the child gave knives
 'The man gave the child knives.'

- (23) a. boraa na [AGRoP zankaa_i noo-AGR [VP t_i t_v zaamay]]
 b. boraa na [AGRioP zankaa_i noo-AGR-AGR [AGRoP zaamay_j t_{agr} [VP t_i t_v t_j]]]

There are at least two reasons to prefer (23)b to (23)a. First, if Case-assignment (checking) is done under Spec-head agreement, it is not clear how *zaamay* "knives" in (23)a can be assigned Case (or have its Case-feature checked). Second, if the Theme object remains in the VP as in (23)a, we will expect that a VP-adverb may occur between the verb and the Theme DP, given the proposed analysis of adverb placement. The prediction fails, however, as shown below.

- (24) a. boraa na zankaa noo zaamay gabaday
the man NA the child gave knives completely
 'The man completely gave the child knives.'
- b. * boraa na zankaa noo gabaday zaamay
the man NA the child gave completely knives

The (un)acceptability of (24)b sharply contrasts with that of (25)b, in which the goal PP remains in a VP-internal position.

- (25) a. boraa na zaamay; noo_v [VP[VP t_j t_v zankaa-see] gabaday]
the man NA knives gave the child-to completely
 'The man completely gave knives to the child.'
- b. boraa na zaamay; noo_v [VP gabaday [VP t_j t_v zankaa-see]]
the man NA knives gave completely the child-to

It seems then reasonable to conclude that the double object construction has a structure like (23)b, at the point of SPELL-OUT, in which the two objects have overtly raised to the specifiers of functional categories between VP and XP.

To summarize this chapter, we have seen that, although Zarma completely lacks visible/audible agreement morphology, it does have Agreement Phrases as characterized in Chomsky (1991; 1993b).

CHAPTER FOUR

INVISIBLE AGR IN JAPANESE

There is an on-going debate as to whether Japanese, a language without audible/visible agreement morphology, has Agreement Phrases as characterized in Chomsky (1991; 1993b) (cf. Tada 1993; Takahashi 1993; Fukuhara 1993; Nemoto 1993). In hoping to decide on the issue, in this chapter, we discuss whether the object in Japanese is Case-licensed in the complement position as in (1)a or in the Spec of AGRo as in (1)b. (As in the preceding two chapters, we suppress subject positions in this chapter, and will return to the issue in Chapter 5.)

(1) a. Government-based Case Theory

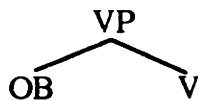

b. Agreement-based Case Theory

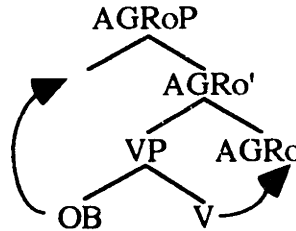

The organization of this chapter is as follows. In § 1, we will lay out the relevant data concerning the Case-licensing position of the object, and state the generalization to be explained. In § 2, we will present a principled account of the data/generalization, based on the Agreement-based Case theory of Chomsky (1993b) as modified by Watanabe (1993). In § 3, we will show that the same range of facts cannot be naturally explained without postulating AGR-type categories. We will thus conclude that the accusative object in Japanese is Case-licensed under the Spec-head agreement, as shown in (1)b, hence Japanese has Agreement Phrases in the sense of Chomsky (1991; 1993b).

1. Syntactic Compounds

Since Japanese is a head final language, and since it allows scrambling relatively freely, simple word order facts fail to provide us with the crucial information necessary to

choose between (1)a and (1)b.¹ Further, as AGRo lacks lexical semantic content by definition, the two structures in (1) do not have detectable semantic differences. Thus, to see if the object raises out of the VP, we need to look into sentences with slightly more complex structures. For this reason, we will study complex predicate sentences of the following sort.

(2) SU OB V1-V2-Tense

a. Emi-ga ringo-o tabe-hazime-ta

Emi-NOM apple-ACC eat-start-PAST

'Emi started to eat apples.'

b. Emi-ga ringo-o tabe-wasure-ta

Emi-NOM apple-ACC eat-forget-PAST

'Emi forgot to eat apples.'

c. Emi-ga ringo-o tabe-rare-ru

Emi-NOM apple-ACC eat-can-PRES

'Emi can eat apples.'

These sentences contain a syntactic (as opposed to lexical) compound consisting of two verbs.² We refer to the first verb of the V-V compounds as V1, and the second as V2. In (2)a, for example, *tabe* "eat" is V1, and *hazime* "start" is V2. The accusative NP in these sentences is the object of V1. V2 takes as complement a constituent that contains V1 and its arguments, as in (3).

(3) [... [... OB V1] V2]

With this much in mind, let us start our investigation.

1.1. Raising vs. Control

First, consider the following sentence.

¹ If Case is an LF requirement (and not an overt one), word order facts would not provide such information anyway (Howard Lasnik, personal communication).

² The distinction between syntactic and lexical compounds will be discussed in § 3.2.

(4) John-ga ringo-dake-o tabe-hazime-ta
John-NOM apple-only-ACC eat-start-PAST
 'John started to eat only apples.'

- i) only > start (It is only apples that John started to eat.)
- ii) start > only (It is eat only apples that John started to do.)

The example (4) is ambiguous with respect to the scope of the object and V2. It may be interpreted either as (4)i or (4)ii. To see the ambiguity more clearly, let us suppose that we, a group of scientists, run an experiment to observe what kinds of fruits a chimpanzee, named John, eats. (5) is the result of the experiment.

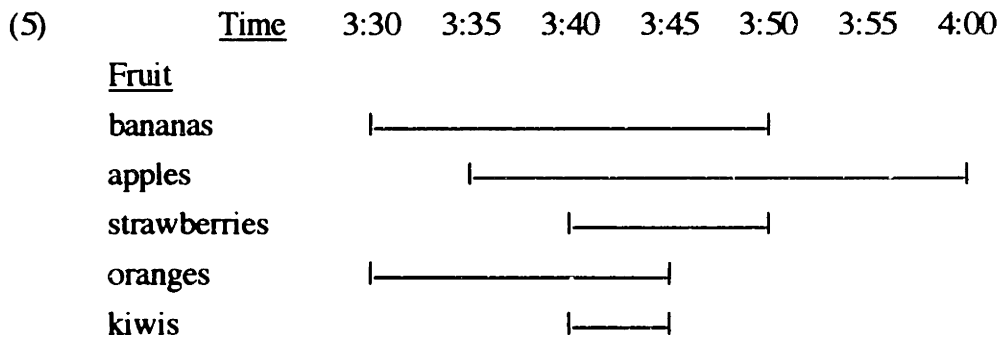

The graph in (5) is supposed to mean that John started to eat bananas at 3:30 and stopped doing so at 3:50, that he ate apples from 3:35 to 4:00, and so on. Now, in discussing the result, we can say (6) as well as (7).

(6) (John-wa) 3-zi-35-hun-ni-wa ringo-dake-o tabe-hazime-ta
(John-TOP) 3:35 -at-TOP apple-only-ACC eat-start-PAST
 'It is only apples that John started to eat at 3:35.' (only > start)

(7) (John-wa) 3-zi-50-pun-ni ringo-dake-o tabe-hazime-ta
(John-TOP) 3:50 -at apple-only-ACC eat-start-PAST
 'At three fifty, John started to only eat apples.' (start > only)

The sentence (6), as used in this situation, means that John started to eat apples at 3:35, and that he didn't start to eat anything else at that time. On this reading, "only apples" clearly has scope over "start." If "start" had wide scope, (6) would mean that at 3:35, John started the following thing, i.e. eating only apples, which clearly is not the case in the situation described in (5), where John was eating not only apples but also bananas and oranges at

3:35 (or a second later). On the other hand, (7) is intended to mean that at three fifty John started the following thing, i.e. eating only apples. Here, "only apples" is in the scope of "start." Note that John did not start eating apples at 3:50. He had started to do so at 3:35. What he started to do at 3:50 is "eat only apples." In other words, what he did at 3:50 is to stop eating all fruits other than apples. The examples in (8) through (10) exhibit similar ambiguities with respect to the relative scope of the object and V2.

- (8) John-wa banana-dake-o tabe-tuzuke-ta
John-TOP banana-only-ACC eat-continue-PAST
 'John kept eating only bananas.'
 i) only > continue (Among many things John ate, it is only bananas that he kept eating (throughout the relevant time span).)
 ii) continue > only (John kept eating bananas, and he didn't eat anything else.)
- (9) John-wa niku-dake-o tabe-sugi-ta
John-TOP meat-only-ACC eat-overdo-PAST
 'John overdid eating only meat.'
 i) only > overdo (Among many things John ate, it is only meat that he overate.)
 ii) overdo > only (For too long time, John ate nothing but meat.)
- (10) John-wa Emi-dake-o home-kake-ta
John-TOP Emi-only-ACC praise-be about to-PAST
 'John was about to praise only Emi.'
 i) only > be about to (It is only Emi that John was to praise.)
 ii) about to > only (It is praise only Emi that John was about to do.)

Not all syntactic V-V compounds yield this kind of ambiguity, however. The sentences in (11) and (12) may only be interpreted in such a way that the object has scope over V2.

- (11) John-wa ringo-dake-o tabe-wasure-ta
John-TOP apple-only-ACC eat-forget-PAST
 'John forgot to eat only apples.'
 i) only > forget (Among many things John was supposed to eat, it is only apples that he forgot to eat.)
 ii) *forget > only (It is eat only apples that John forgot to do.)

- (12) Mary-wa gengogaku-no ronbun-dake-o kaki-oe-ta
Mary-TOP linguistics-GEN paper-only-ACC write-finish-PAST
 'Mary finished writing only a linguistics paper.'
 i) only > finish (Among many papers Mary was supposed to write, it is only
 a paper on linguistics that she finished writing.)
 ii) *finish > only (It was writing only a paper on linguistics that Mary
 finished.)

It is not the case that the readings (11)ii and (12)ii are semantically anomalous, because the intended meanings can be felicitously expressed by the following sentences, in which the embedded clauses have a tense/aspectual marker and a complementizer.

- (13) (cf. (11))
 John-wa [ringo-dake-o tabe-ru no]-o wasure-ta
John-TOP apple-only-ACC eat-PRES that-ACC forget-PAST
 Lit. 'John forgot that eats only apples.'
 (What John was supposed to do was to eat only apples, but he forgot to do so.)
- (14) (cf. (12))
 Mary-wa [gengogaku-no ronbun-dake-o kak-u koto]-o oe-ta
Mary-TOP linguistics-GEN paper-only-ACC write-PRES that-ACC finish-PAST
 Lit. 'Mary finished that writes only a linguistics paper.'
 (Mary finished the following thing, i.e. writing only linguistics papers.)

The crucial difference between the two classes of compounds seems to be that the class of compounds that do not induce scope ambiguity have a Control verb as V2 ((11) and (12)), whereas those with ambiguity have as V2 either a Raising verb ((9) and (10)) or a verb ambiguous between Raising and Control ((4) and (8)).

(15) Raising vs. Control

Raising verbs	Control verbs	Raising/Control verbs
- <i>sugi</i> "do too much"	- <i>wasure</i> "forget"	- <i>hazime</i> "begin"
- <i>kake</i> "be about to"	- <i>oe</i> "finish"	- <i>tuzuke</i> "continue"
- <i>owar</i> "come.to.an.end"	- <i>age</i> "complete"	- <i>das</i> "start"
	- <i>naos</i> "re-do"	
	- <i>sokonaw</i> "fail"	

(cf. Shibatani 1978; Nishigauchi 1993, etc.; Kageyama 1993)

In other words, the subject in (11) and (12) is an argument of V2, controlling the implicit embedded subject (PRO), whereas the subject in (9) and (10) is an argument of V1, raised to the matrix subject position. The subject in (4) and (8) is ambiguous between the two possibilities.

There are several operational tests that can be used to determine whether a particular verb is a Raising verb or a Control verb. Detailed discussions can be found in Nishigauchi (1993) and Kageyama (1993). It is not necessary, for our purposes here, to repeat all of them. We will just mention two heuristic procedures. First, Control verbs typically have an external- θ role and an Accusative Case feature; while Raising verbs have neither (cf. Burzio's Generalization, Burzio 1986). Thus, Control verbs tend to have a simple transitive use with an accusative object, but Raising verbs do not. This is shown below.

(16) a. pure Raising verb

* John-ga sigoto-o kake-ta
John-NOM job-ACC be.about.to-PAST
Lit. 'John was about to job.'

b. pure Control verb

John-ga sigoto-o wasure-ta
John-NOM job-ACC forget-PAST
'John forgot (to do) a job.'

c. Raising/Control verb

John-ga sigoto-o hazime-ta
John-NOM job-ACC start-PAST
'John started to work.'

Second, Control verbs require the referent of their subject to be something that can be a controller, typically humans or higher animals. This restriction does not hold for Raising verbs because the surface subject of the Raising construction is not an argument of the Raising predicate. Thus, Raising verbs allow non-animate subjects as far as V1 does, but Control verbs do not.

- (17) Ame-ga hut-ta
Rain-NOM fall-PAST
 Lit. 'Rain fell.' (It rained.)
- (18) a. pure Raising verb
 Ame-ga huri-kake-ta
rain-NOM fall-be.about to-PAST
 Lit. 'Rain was about to fall' (It was about to rain.)
- b. pure Control verb
 * Ame-ga huri-wasure-ta
rain-NOM fall-forget-PAST
 Lit. 'Rain forgot to fall.'
- c. Raising/Control verb
 Ame-ga huri-hazime-ta
rain-NOM fall-start-PAST
 Lit. 'Rain started to fall.' (It started to rain.)

The results of the two tests can be summarized as follows.

(19)	Raising	Control	Raising/Control
Transitive use	*	✓	✓
Non-animate subject	✓	*	✓

To conclude this subsection, we have found the generalization that the object in the Raising construction may have either narrow or wide scope with respect to the Raising verb, while the object in the Control construction may not have narrow scope with respect to the Control verb.

1.2. Stative Compounds

We considered non-stative complex predicates in the previous subsection. In this subsection, we turn our attention to stative complex predicates. Before beginning our discussion of the relative scope of the object and the stative V2, we need to make a short excursion into case marking of objects in Japanese.

In Japanese, the object of a simple transitive sentence is marked with the accusative marker *o* when the predicate is non-stative ([-stative]), while it is marked with the nominative marker *ga* when the predicate is stative ([+stative]) (cf. Kuno 1973). In (20), the verb is [-stative], and the object must take the accusative marker. In (21), the verb is [+stative], and the object must take the nominative marker.³

(20) Simple [-stative] predicates

a. John-ga piza-o tabe-ru
John-NOM pizza-ACC eat-PRES
'John eats pizza.'

b. * John-ga piza-ga tabe-ru
John-NOM pizza-NOM eat-PRES

(21) Simple [+stative] predicates

a. * John-ga huransugo-o deki-ru
John-NOM French-ACC capable-PRES
'John is capable of French.' (John speaks French.)

b. John-ga huransugo-ga deki-ru
John-NOM French-NOM capable-PRES

The above examples indicate that non-stative verbs have the ability to license Accusative Case features, and stative verbs (stative predicates, more generally) the ability to license Nominative Case features.⁴

³ We will not be concerned here with exactly how the stativity is defined that is relevant in characterizing the two classes of predicates in question. See Kuno (1973: Chapter 4) for discussion.

⁴ Elsewhere (1994a), I have argued that stative predicates in Japanese in fact are lacking ability to license structural Case altogether, and the Nominative Case of the nominative object is licensed not by a stative verb but by Tense. I will adopt this analysis later in this chapter.

When the degree of the stativity of the predicate is on the borderline, or ambiguous, between [+stative] and [-stative], the object may be marked with either *ga* or *o*, the preference being determined by discourse factors including the meaning of the sentence itself (cf. Sugioka 1984: Chapter IV):

(22) Borderline cases

- | | | | |
|----|----------------------------|-------------------|------------------------|
| a. | ? John-ga | huransugo-o | wakar-u |
| | <i>John-NOM</i> | <i>French-ACC</i> | <i>understand-PRES</i> |
| | 'John understands French.' | | |
| b. | John-ga | huransugo-ga | wakar-u |
| | <i>John-NOM</i> | <i>French-NOM</i> | <i>understand-PRES</i> |

The optionality of case marking can also be observed with a complex predicate consisting of a [-stative] predicate and a [+stative] predicate. This is illustrated in (23), with [-stative] verb *hanas* "speak" and [+stative] verb (*rar*)*e* (potential, "can").⁵

(23) Complex predicates: [-stative]+[+stative]

- | | | | |
|----|--------------------------|-------------------|-----------------------|
| a. | John-ga | huransugo-o | hanas-e-ru |
| | <i>John-NOM</i> | <i>French-ACC</i> | <i>speak-can-PRES</i> |
| | 'John can speak French.' | | |
| b. | John-ga | huransugo-ga | hanas-e-ru |
| | <i>John-NOM</i> | <i>French-NOM</i> | <i>speak-can-PRES</i> |

Note that the potential verb is a Control predicate, thus it does not allow inanimate subjects:

- (24) *Ame-ga hur-e-ru
Rain-NOM *fall-can-PRES*
 Lit. 'Rain is able to fall.'

⁵ Here we only discuss one type of potential construction exemplified in (23), i.e. the Potential of Ability construction with a nominative subject. See Nakayama & Tawa (1988), Okada (1989), and Koizumi (1990) for other types of potential constructions in Japanese.

Returning to the issue of scope, Tada (1992) observes that the accusative-marked quantified object "only the right eye" in (25)a is within the scope of the potential verb *-(rar)e* "can", whereas the nominative object in (25)b has scope over *-(rar)e*.

- (25) a. John-ga migime-dake-o tumur-e-ru
John-NOM right.eye-only-ACC close-can-PRES
 'John can close only his right eye.'
 i) can > only (John can wink his right eye.)
 ii) ?*only > can (It is only his right eye that he can close.)
- b. John-ga migime-dake-ga tumur-e-ru
John-NOM right.eye-only-NOM close-can-PRES
 'John can close only his right eye.'
 i) *can > only
 ii) only > can

The same point can be made with the following pair of sentences, where the accusative object has narrow scope with respect to the potential verb, whereas the nominative object has wide scope.⁶

- (26) a. John-wa baabon-dake-o nom-e-ru
John-TOP bourbon-only-ACC drink-can-PRES
 'John can drink only bourbon.'
 i) can > only (John can drink straight bourbon.)
 ii) ?*only > can (It is only bourbon that John can drink.)
- b. John-wa baabon-dake-ga nom-e-ru
John-TOP bourbon-only-NOM drink-can-PRES

⁶ There seems to be two varieties of idiolects. Some speakers (including Tada and myself) find sentences like (25)a and (26)a unambiguous, with the accusative object taking narrow scope. Others judge them to be ambiguous. In the text, we focus on the grammar(s) of the former group of people. For the grammar(s) of the latter type of speakers, see note 14.

The sentences in question allow the object wide scope reading for all speakers if the object is stressed or focused. The object wide scope reading in this case may be induced by scrambling or focus movement. Throughout the paper, we neglect weak secondary readings due to scrambling/focus movement, as they have no crucial bearing on our discussions.

- i) *can > only (John can drink straight bourbon.)
- ii) only > can (It is only bourbon that John can drink.)

Combining the observations of the present subsection with those of the previous one, we will obtain the following table.

(27) Facts to be explained

Matrix verb (V2)	Case of the object	Scope	
		object > V2	V2 > object
Raising	Accusative	✓	✓
Control	Accusative	✓	*
Stative	Accusative	*	✓
Stative	Nominative	✓	*

We will present an account of this paradigm in the next section.⁷

⁷ We have seen that the scope of the object with respect to V2 differs depending on the type of V2. The scope of the subject, in contrast, seems to be invariable. The subject uniformly takes wide scope with respect to V2 regardless of the type of V2. The subject narrow scope reading, if available at all, is very weak. Consider the following sentences.

- (i) a. Raising
 Emi-dake-ga ringo-o tabe-sugi-ta
Emi-only-NOM apple-ACC eat-overdo-PAST
 'Only Emi overate apples.'
 i) ?*overdo > only (It happened too many times that only Emi apples.)
 ii) only > overdo (It was only Emi who ate too many apples.)
- b. Control
 Emi-dake-ga syukudai-o dasi-wasure-ta
Emi-only-NOM assignment-ACC hand.in-forget-PAST
 'Only Emi forgot to hand in the assignment.'
 i) *forget > only (???)
 ii) only > forget (It was only Emi who forgot to hand in the assignment.)
- c. ambiguous between Raising and Control
 Emi-dake-ga ringo-o tabe-hazime-ta
Emi-only-NOM apple-ACC eat-start-PAST
 'Only Emi started to eat apples.'
 i) *start > only (The following thing began, i.e. only Emi ate apples.)
 ii) only > start (It was only Emi who started to eat apples.)
- d. Potential (stative Control)
 Emi-dake-ga piano-o/-ga hik-e-ru
Emi-NOM piano-ACC/-NOM play-can-PRES
 'Only Emi can play the piano.'

(→ccntinue)

2. A Minimalist Account

We have seen in § 1.1 that the object of the Raising construction may take either matrix or embedded scope. The most straightforward way to derive this optionality within the minimalist framework is to hypothesize two potential Case-checking positions for the object, one within the embedded domain, the other in the matrix domain.⁸ This is schematically shown in (28)a.

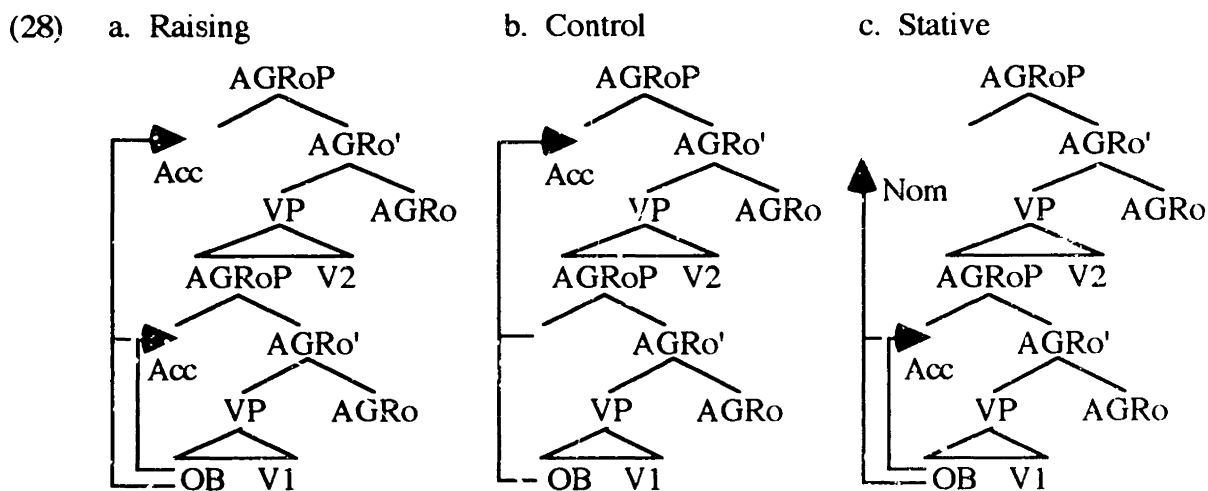

Following the same reasoning, it must be the case i) that the object of the Control construction can only be Case-licensed in the matrix domain as in (28)b, ii) that the accusative object of the Potential stative construction can only be Case-licensed within the embedded domain as in (28)c,⁹ and iii) that the nominative object of the Potential

-
- i) *can > only (It is possible that only Emi plays the piano.)
 - ii) only > can (It is only Emi who can play the piano.)

These examples suggest that the subject takes matrix scope not only in Control sentences but also in Raising sentences as well. (There are a few sporadic exceptions to this generalization.)

⁸ An implicit assumption here is that, either there is no QR, or if QR does exist, it is clause-bounded in the strictest sense (i.e., QR does not cross a clause boundary ("extended projection" of V) whether it is tensed or non-tensed). Cf. Kitahara (1992), Snyder & Pica (1994), and Fox (Fox 1994). See also § 3.1 of the present chapter.

⁹ The phonetically null embedded subject of the Control construction is licensed within the embedded domain, possibly in the Spec of VP. See Chapter Five for subject positions.

construction can only be Case-licensed in the matrix domain as in (28)c. The question then is, why is it that the object of the Control construction and the nominative object of the Potential construction cannot be Case-licensed in the Spec of the embedded AGRO? and why is it that the accusative object of the Potential construction cannot be Case-licensed in the Spec of the matrix AGRO? To answer these questions, we take a closer look at the derivations of these constructions. In § 2.1, we briefly explain the version of Agreement-based Case theory assumed here. Then, in § 2.2, we discuss the derivations of the three constructions under this theory.

2.1. Three-layered Case Theory

In Chomsky (1991; 1993b), the Case of an NP is licensed if the NP moves into the Spec of AGR and if a Case-feature bearing element such as V or T raises to this AGR. Watanabe (1993:56) proposes that there is an additional process related to Case-checking. During the process of Case-checking, a new feature [F] is created in AGR, and AGR has to undergo further movement to a higher functional head to check off this [F] feature. An [F] feature created in AGRs needs to be checked by C, and an [F] feature created in AGRO must be checked by T. For example, in (29), an [F] feature is created in AGRO when the verb and the object enter into the checking relation in the domain of AGRO at LF. The V+AGRO complex then raises to T in order to have the [F] feature checked off.

(29) Mary met John.

a. $[\text{AGR}_{\text{SP}} \text{Mary AGRs} [\text{TP T} [\text{AGRO}_{\text{P}} \text{AGRO} [\text{VP } t_{\text{su}} \text{ met John}]]]]$
|
|
[Acc] [Acc]

↓ Raising V to AGRO
 Raising OB to Spec AGRO
 ↓ Accusative Case-checking, creating [F] in AGRO

b. $[\text{AGR}_{\text{SP}} \text{Mary AGRs} [\text{TP T} [\text{AGRO}_{\text{P}} \text{John} [\text{AGR}' \text{met-AGRO} [\text{VP } t_{\text{su}} t_{\text{v}} t_{\text{ob}}]]]]]$
|
[F]

↓ Raising V-AGRO to T
 [F] checked off

c. $[\text{AGR}_{\text{SP}} \text{Mary met-AGRO-T-AGRs} [\text{AGRO}_{\text{P}} \text{John} [\text{AGR}' t_{\text{agr}} [\text{VP } t_{\text{su}} t_{\text{v}} t_{\text{ob}}]]]]]$

If the [F] feature created in AGRO is not checked by T, the Case checking process will not be licensed. Thus, the Case feature of the object NP remains unlicensed, which in turn will

cause the derivation to crash, resulting in ungrammaticality. The three-layered Case theory is motivated in part by Watanabe's observation that there is a correlation, in many languages, between the shape of C and the possibility of Nominative Case licensing, and between the shape of T and the possibility of Accusative Case licensing. Thus, in the three-layered Case theory, T plays a crucial role in licensing Accusative Case.

One might wonder, at this moment, what happens in languages like French, in which the main verb overtly raises to AGRs, and the object does not raise to the Spec of AGRo until LF. When Accusative Case checking takes place in LF, an [F] feature is created in the trace of AGRo, as in (30).

(30)

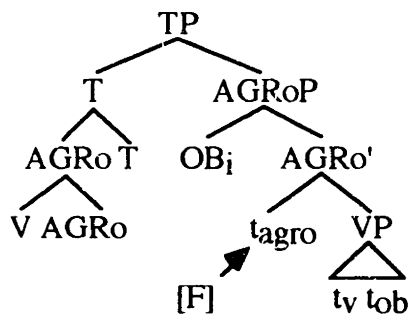

Since AGRo has already raised to T, the [F] feature in the trace of AGRo can never be in the checking domain of T. Then the object in languages like French should not be able to bear Accusative Case, a clearly wrong prediction. One might take this to be a problem with the three-layered Case theory. It is not, however. The reasoning above is based on the tacit assumption that features such as an [F] feature belong to a particular member of a chain, rather than to the whole chain. Although it is one of many logically possible assumptions, it is not the one adopted in the minimalist framework. In this framework, members of a chain are not syntactic objects by themselves, rather they are parts of a syntactic object, i.e. a chain (see Chomsky 1994 on this point). Thus it is a mistake to think of a syntactic feature as something belonging to a member of a chain. All features relevant to syntax belong to an entire syntactic chain, rather than to a particular member of a chain. Viewed this way, the [F] feature in (30) is created in the AGRo chain, not in the trace of AGRo, hence it can be successfully checked off by T, as the AGRo chain is in the checking domain of T.

Returning to our central concern, I adapt the insight of Watanabe's three-layered Case theory, and modify our Case theory as follows. Recall that in §4 of Chapter 2, I

suggested that Case-checking consists of two steps, i.e. copying of the Case-feature of a DP onto AGR, and copying the Case-feature of V or T to AGR. If the two features are of the same type, the Case-checking is successful; it is not otherwise. Thus, AGR has the information whether or not the Case-checking that took place in the domain of that AGR was successful. Now suppose that at the LF interface level, it is checked whether all Case-checkings were successful in order to determine whether or not all DPs are legitimate LF objects. To see if a Case-checking was successful, you need to look at the AGR in whose domain the checking took place, as I mentioned above. Crucially, however, AGR is semantically inert hence invisible at the LF interface level. Thus, if the information regarding whether or not a Case-checking was successful is stored only in AGR, you cannot access the information at the LF interface level, hence you cannot know if it was successful, an obviously unwanted conclusion. Let us then suppose, following the spirit of Watanabe's (1993) three-layered Case-theory, that a Case-checking involves an additional third process. That is, suppose that, after the Case-features of a DP and V or T are copied onto AGR, the pair of the Case-features are copied (or transferred) from AGR onto a semantically active functional head such as T or C when AGR is in the checking domain of the latter (T or C).

Under this modification, the Case-licensing of a typical Accusative object consists of the following three steps: i) copying of the Case-feature of the object DP to AGR_o, ii) copying of the Case-feature of the verb to AGR_o, and the copying of the pair of the Case-features, previously copied onto AGR_o, onto T. These three processes are all done under the structural condition of "being in the checking domain" (e.g. the DP is in the checking domain of AGR). If the pair of Case-features in T are the same type, the object DP is considered to be Case-licensed (hence, legitimate in this regard) at the LF interface level. Now finally, to prevent the Case-features of AGR_o from being copied onto C, let us assume that a lexical item (lexical category or functional category) with an original (not copied) Case-feature constitutes an opaque domain for the purpose of feature copying. Thus, in the partial structure (31) created by successive head movement, if AGR_o has a pair of Case-features previously copied onto it from the object and the verb, they may be re-copied onto T, but not onto C because of the intervening T with an original Nominative Case feature.¹⁰

¹⁰ I assume the following definition of *intervention*.

(→*continue*)

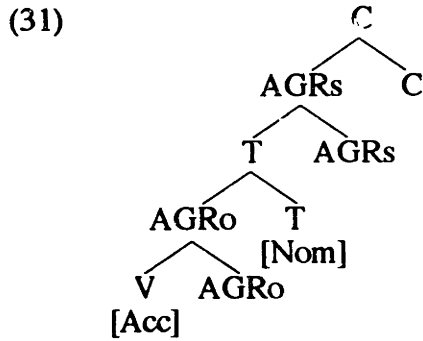

With this much in mind, let us consider derivations of the complex predicate constructions.

2.2. Derivations

We begin with the Raising construction. Suppose that the object raises to the Spec of the embedded AGRo at LF. For the reasons of locality discussed in Chomsky (1993b), V1 must raise to the embedded AGRo before the object raises to its Spec, as shown in (32).¹¹

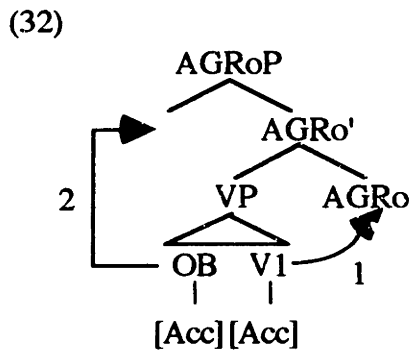

The Accusative Case features of the object and the verb are copied onto the embedded AGRo. Subsequently, the pair of the Case features are copied from the embedded AGRo

- i) α intervenes between X and Y iff a) or b).
 - a) X contains α , and α contains Y.
 - b) Y contains α , and α contains X.
- ii) X contains Y iff a segment of X dominates Y.

¹¹ In Chapter 7, we will see evidence that verbs in Japanese raise to C in overt syntax.

to T, when the embedded AGRo raises to the checking domain of T through successive raising of intervening functional heads, as shown in (33). Since Raising verbs do not have their own Case features, V2 in the Raising construction does not block the feature copying from the embedded AGRo to T.

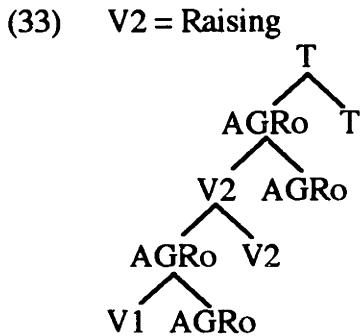

In this derivation, the object is Case-licensed in the embedded domain, hence takes embedded scope.

Let us next consider the derivation that yields the object wide scope reading. Note that the higher verbs (i.e. V2) of the three constructions we have been considering are all so-called Restructuring verbs. As noted in Rizzi (1982: Chapter I) and others, modals, aspectuals, and motion verbs typically belong to this class cross-linguistically. Further, it is generally agreed that Restructuring is an optional process. Miyagawa (1986) shows, using such motion verbs as *iku* "go" and *kuru* "come", that Japanese also has productive Restructuring processes, and that they are optional. It seems then reasonable to assume that the modals and aspectuals we have been discussing optionally trigger Restructuring. The derivation of the Raising construction we have seen above then is that of when Restructuring does not take place. When Restructuring does apply, that is, when V1 raises to V2 and has its Case-feature transferred to V2 without having it copied onto the embedded AGRo, the object DP cannot be Case-licensed in the Spec of the embedded AGRo, as the embedded AGRo does not have a matching Case. The object then has to move up to the Spec of the matrix AGRo, where its Case-feature is copied onto the matrix AGRo, and matched against the Case-feature copied from V2 (which has been transferred from V1 as a result of Restructuring). The matrix AGRo enters into the checking relation with T when it adjoins to T, recording on T whether the two Case features are of the same type. This accounts for the object wide scope reading of the Raising construction.

We now turn to the Control construction, which we saw has only the object wide scope reading. Let us first consider the case in which the object DP raises to the Spec of

the embedded AGRo to have its Accusative Case feature checked against the Case feature of V1. The derivation goes in the manner exactly parallel to that of the derivation of the Raising construction without Restructuring, and at a certain point we get the following partial structure, corresponding to (33) of Raising.

(34) V2 = Control

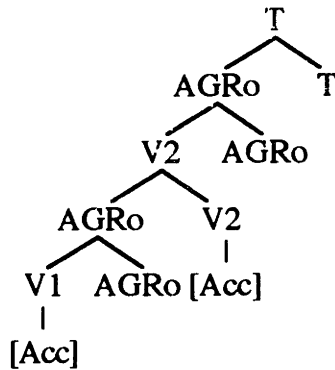

The structure in (34) is minimally different from (33) in that V2 has an original Accusative Case-feature. Recall that we saw in § 1.1 that the Japanese Control verbs in question have Accusative Case features. Under the Case theory assumed here, for the Case-licensing process between the object and the embedded AGRo to be finalized, the pair of Case-features previously copied to AGRo must be re-copied to T. It is possible in (33) but not in (34), because in (34) the embedded AGRo and T are separated by a category with an original Case-feature, i.e. V2, which constitutes an opaque domain for feature copying. For this reason, the object in the Control construction cannot be Case-licensed in the Spec of the lower AGRo, hence it never is able to take embedded scope.

The only way for the object to be Case-licensed in the Control construction is to move to the Spec of the matrix AGRo, where its Accusative Case feature can be checked against the Accusative feature of the Control verb by both being copied onto the matrix AGRo. This derivation yields the object wide scope reading of the Control construction.¹²

Finally, let us turn to the stative sentences with the potential verb as V2, in which the accusative object takes narrow scope with respect to the potential verb, while the

¹² In the Control construction, not only the object but also adjuncts obligatorily take wide scope with respect to V2. To the extent that the proposed analysis of the object wide scope reading is correct, this fact supports Oka's (1993a) claim that adjuncts need be Case-checked (in some sense).

nominative object takes wide scope with respect to the potential V2. When Restructuring does not apply, the accusative object raises to the Spec of the embedded AGRo, where its Case-feature is copied onto the AGRo and compared with the Case-feature copied from V1 to the AGRo. Although the potential verb is a Control verb, it does not have Accusative Case features because it is a stative verb. As we saw in § 1.2, stative verbs in Japanese do not have Accusative Case features. Thus, in the potential construction, there is no intervening structural Case bearer between the embedded AGRo and T.¹³ The two Case-features in the embedded AGRo therefore can be copied to T successfully.

When Restructuring applies, the Accusative Case feature of V1 is absorbed by the potential verb. Thus, the object cannot be Case-licensed in the Spec of the embedded AGRo. It must therefore undergo raising to a position where it can be Case-licensed. The Spec of the matrix AGRo is not an option this time, because the potential verb, being a stative predicate, does not have ability to license structural Case even if it absorbs an Accusative Case feature from V1 (see § 1.2) (recall that in Japanese, stative predicates lack Accusative Case features). This means that when Restructuring applies, the object with an Accusative Case feature cannot be Case-licensed. Hence, the accusative object is possible in the Potential construction only when Restructuring does not apply. Since the accusative object in this construction is Case-licensed in the Spec of the embedded AGRo when Restructuring does not apply, it takes narrow scope with respect to the potential verb.¹⁴

As for the nominative object, I have argued elsewhere (Koizumi 1994a), assuming Chomsky's (1993b) Case theory, that it is Case-licensed in the Spec of T. That is, when V1 undergoes Restructuring with the potential verb, the nominative object raises to the Spec of T. In the Spec of T, its Nominative Case feature is checked against a Nominative Case-feature of T. T in Japanese differs from T in English, French, etc. in that it may have more than one Nominative Case feature (cf. Ura 1994a, and references cited there. See also Chapter 7). Thus, it can license the Nominative Case of the nominative object as well

¹³ I assume, following Koizumi (1994a), that stative predicates lack structural Case features altogether. Thus, they have neither Accusative nor Nominative Case features.

¹⁴ It might be the case that for those who find sentences like (25)a and (26)a ambiguous, stative predicates have ability to use an Accusative Case-feature if they get one from a non-stative predicate. If so, the Case-feature can be copied from the potential verb to the matrix AGRo, and matched against the Case feature copied from the object in the Spec of the matrix AGRo. This conjecture, if correct, may account for the idiolectal variation noted in note 6.

as the Nominative Case of the subject. Since the Spec of T is higher than (the chain of) the potential verb, the nominative object always has wide scope with respect to the potential verb.¹⁵ This account is not available for us if we assume that Case-checking is always mediated by AGR as suggested in §4 of Chapter 2: The Spec of T being outside the checking domain of AGRs, the Nominative Case feature of the nominative object in the Spec of T cannot be copied to AGRs. I would like to suggest the following minimal modification: Instead of moving to the Spec of T, the nominative object *adjoins to TP* in LF. Since the TP-adjoined position is in the checking domain of AGRs under the definition of the checking domain given in Chomsky (1993b), the nominative object can enter into the checking relation with AGRs. Thus, the Nominative Case feature of the nominative object can be copied to AGRs. It will eventually be re-copied to C along with the Nominative Case feature of T previously copied to AGRs.¹⁶

To summarize, I have shown that the scope facts we observed in § 1 are readily explained by a version of three-layered Case theory couched in the minimalist framework

3. Alternative Analyses

In this section, we discuss how the scope facts in question might or might not be handled by theories such as a Government-based Case theory in which the accusative object is Case-licensed in its base position as sister to a verb.

¹⁵ When Restructuring does not apply, the nominative object probably cannot be Case-licensed. This is because, when it raises to the Spec of the embedded AGRO on its way to the Spec of T, its Case-feature is wrongly checked against the Accusative feature of V1, which presumably yields ungrammaticality.

¹⁶ Alternatively, we might adopt Chomsky's (Class lectures, Fall 1994) suggestion that what moves in LF for the purpose of feature checking is not a category, but rather is a set of relevant features. Given this, the Nominative Case feature of the nominative object in Japanese adjoins to (or copied onto) the head AGRs in LF, without pied-piping the whole object.

Harley (1994) rather convincingly shows that the nominative object in Icelandic occupies the Spec of AGRO at the point of SPELL-OUT. She then suggests that it is Case-licensed in that position (the Spec of AGRO) by the verb with a Nominative Case feature. If so, the nominative object in Icelandic and the nominative object in Japanese are Case-licensed in two different ways. Another possibility is that the overt object shift to the Spec of AGRO in Icelandic is triggered by reasons other than Case (e.g. checking of ϕ -features), and the nominative object raises to the TP-adjoined position in LF (or the Nominative Case feature adjoins to AGRs), like in Japanese.

If A and B in (35) hold, the object of the complex predicate sentences should be in the complement domain of V2 at LF. Thus, following the standard assumption given in (35)C, it is expected that the object of the complex predicate sentences invariably takes narrow scope with respect to V2.

- (35) A: The object of the complex predicate sentences is Case-licensed in the complement position of V1.
B: The object of the complex predicate sentences stays in the Case position throughout the derivation.
C: The relative scope among elements reflects their relative heights in the LF representation (i.e., if α c-commands β , α may take wide scope with respect to β).

This prediction is borne out only in the Potential construction with the accusative object. The object wide scope readings of the other constructions remain without explanation. Thus, (at least) one of the three assumptions above (i.e. A, B, and C) must be abandoned. In the previous section, we saw that the minimalist framework, which does not assume (A), can provide a principled account to the scope facts in question. Since (C) is relatively well established in literature, and there seems to be no obvious simple alternative, we will not question its validity here. Instead we consider the possibility of discarding either (A) or (B) within a GB-type framework.

3.1. Quantifier Raising

In the standard GB theory, (B) is discarded in favor of Quantifier Raising, which adjoins a quantificational element such as a quantified NP to a clausal category (i.e. IP or VP) in LF (cf. May 1977; 1985). Under this analysis, the object of the Raising construction may be raised by QR either to the embedded clause or to the matrix clause, as shown in (36)a below (where CL stands for some clausal category such as VP). When the object is adjoined to the embedded clause, it has narrow scope with respect to V2, and when it is adjoined to the matrix clause, it has scope over V2. Thus, QR easily accounts for the scope ambiguity of the Raising construction.

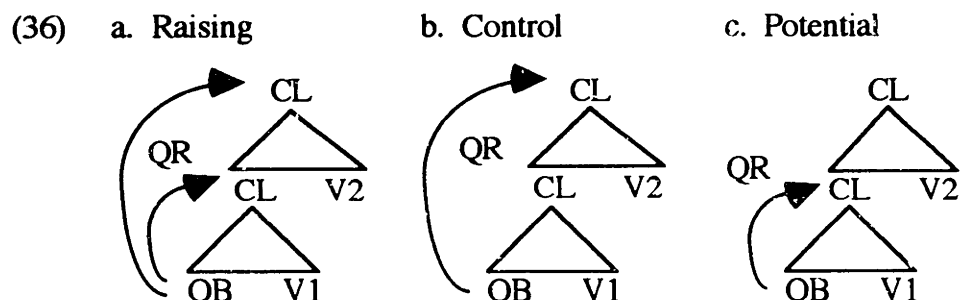

The QR analysis has difficulty in accommodating the scope facts of the Control and Potential constructions, however. In the Potential construction, the accusative object is obligatorily in the scope of V2. If QR can raise the object of this construction to the matrix domain as in the Raising construction, the object should be able to take matrix scope. To prevent this, it must somehow be guaranteed that QR does not raise the object out of the embedded domain in the Potential construction. Given that QR can freely adjoin a QP to any clausal category, it is not easy to make sure of it. Although it has often been observed in literature that QR seems to be tensed-clause bound, this is not enough to constrain QR in this case, because the embedded clause in the Potential construction is not a tensed clause. The embedded clause does not even seem to have a Tense node. It is more like a VP than an IP. On the other hand, if we assume that QR cannot cross clause boundaries, tensed or untensed, we would then lose the way of making the object wide scope readings possible in the Raising and Control constructions. The notion of "barrier" in the sense of Chomsky (1986b) do not help the account, either. For one thing, if the embedded clause of the Potential construction is a barrier for movement, thereby preventing the object from being QRred to the matrix clause, any kind of movement out of the embedded clause should be impossible, a clearly wrong prediction. The object can be scrambled to the sentence initial position without yielding any kind of deviancy. Another problem with postulating a barrier here is that if the embedded clauses of the complex predicate constructions are all barriers, QR should be prevented from raising the object to the matrix domain not only in the Potential construction but also in the Raising and Control constructions, again an incorrect prediction. Of course, it is not impossible to suppose that the embedded clause of the Potential construction, but not those of the other two constructions, is a barrier. Prima facie, there is no obvious reason for this assumption, however. Even if this problem can be resolved somehow, there is still a good reason to believe that the Potential construction does not involve a barrier, as mentioned above.

Even more problematic is the Control construction, where the object always takes matrix scope. Note that the problem we have with the Potential construction above is ensuring the locality of QR, i.e. preventing QR from moving too far. Although we are currently unable to pin point the exact reason why QR, but not scrambling etc., should be subject to such a strict locality condition in the Potential construction, the pattern of the problem itself is not an unfamiliar one. We observe similar (though not identical) locality conditions with respect to other types of movement such as wh-movement, scrambling, and head movement. In contrast, the problem we have with the Control construction when we take the QR approach is quite a different one. It seems as if we have to assume that QR must be long distance in the Control construction. This is a type of "anti-locality condition" we have not previously encountered. All the familiar locality conditions state in one way or another that movement may not be *too long*. What we have to say in the case of the Control construction, on the other hand, is that QR may not be *too short*. Current syntactic theories, including GB theory, crucially do not have any theoretical device to cope with such situation.¹⁷

In short, if we are to account for the scope facts in question by way of QR, we must explain why QR cannot be too long in the Potential construction and why QR cannot be too short in the Control construction. The current syntactic theories cannot even begin to provide answers to these questions. It is safe to conclude, therefore, that the QR approach does not seem to be a promising analysis of the above facts (cf. Kitahara 1992; Snyder and Pica 1994).

3.2. Complex Control Predicates as Lexical Compounds

In most syntactic theories including GB theory, the object is Case-licensed in the complement position of its θ -role assigner. Thus, if the complex predicate constructions all have a structure like (37), as we have been assuming, the assumption (A) above (i.e. that the object of the complex predicate sentences is Case-licensed in the complement position of V1) is inevitable.

(37) [... [... OB V1] V2]

¹⁷ Furthermore, the "anti-locality condition" contradicts the generalization that QR is overwhelmingly clause-bound (Noam Chomsky, personal communication).

On the other hand, it is not totally inconceivable that some of the three constructions might have a different structure. In particular, if the Control construction has a structure like (38), i.e. if a Control complex predicate is a lexical compound formed prior to lexical insertion, it follows straightforwardly that the object cannot take embedded scope, because there is no such thing as embedded clause in (38).

(38) [... OB [V V1-V2]]

Unfortunately, complex Control predicates are not lexical compounds. As noted in Kageyama (1982; 1989; 1993), lexical compounds (compounds formed in lexicon) such as *kaki-kom* "write-insert" and *tobi-agar* "jump-rise" and post-lexical compounds (compounds formed in the syntax, including PF) such as *kaki-hazime* "write-begin" and *tobi-tuzuke* "jump-continue" differ in several respects including the following:

- (39) i. The meanings of lexical compounds are opaque and must be learned individually (they tend to undergo semantic drift and lexicalization), while the meanings of post-lexical compounds are completely transparent (they are interpreted straightforwardly in the functional-compositional manner).
- ii. The productivity of lexical compounds is relatively low, with idiosyncratic variations, whereas post-lexical compounds invariably are highly productive.
- iii. Syntactic processes may access the first element of post-lexical compounds, but not the first element of lexical compounds (lexical integrity).

As an illustration of the third point, consider the following examples with *soo si* ("do so") replacement. *soo si* is a proform of a verbal projection such as VP.

(40) Pro VP: (OB-ACC) + V1 \Rightarrow *soo si* "do so"

lexical compounds

- a. *kaki-kom*(ta) "write-insert" \rightarrow **soo si-kom*(ta)
- b. *tobi-agar*(ta) "jump-rise" \rightarrow **soo si-agar*(ta)
- c. *naki-yam*(ta) "cry-stop" \rightarrow **soo si-yam*(ta)

post-lexical compounds

- d. kaki-hazime(ta) "write-begin" → **soo si-hazime(ta)**
- e. tobi-tuzuke(ta) "jump-continue" → **soo si-tuzuke(ta)**
- f. naki-kake(ta) "cry-be about to" → **soo si-kake(ta)**

In (40)a-c, the anaphoric element *soo si* "do so" is part of a lexical item. Their ungrammaticality may be attributed to a violation of the Anaphoric Island Constraint of Postal (1969), which bans lexical items containing an anaphoric element. This is an instantiation of a more general condition that syntax cannot access internal structure of lexical items (structural integrity of lexical items). An analogous distinction between lexical compounds and post-lexical compounds can be made with the honorific marking on verbs *o-V-ni nar*. The honorific marking is possible on the first member of post-lexical compounds but not on the first member of lexical compounds.

(41) Subject Honorification: *o-V1-ni nar*

lexical compounds

- a. kaki-kom(ta) "write-insert" → ***o-kaki-ni nari-kom(ta)**
- b. tobi-agar(ta) "jump-rise" → ***o-tobi-ni nari-agar(ta)**
- c. naki-yam(ta) "cry-stop" → ***o-naki-ni nari-yam(ta)**

post-lexical compounds

- d. kaki-hazime(ta) "write-begin" → **o-kaki-ni nari-hazime(ta)**
- e. tobi-tuzuke(ta) "jump-continue" → **o-tobi-ni nari-tuzuke(ta)**
- f. naki-kake(ta) "cry-be about to" → **o-naki-ni nari-kake(ta)**

Control complex predicates are post-lexical compounds according to these criteria. They are highly productive, their meanings are perfectly predictable, and they allow syntactic processes to access their first member.

(42) Control complex preds -- Pro VP: (OB-ACC) + V1 ⇒ *soo si* "do so"

- a. kaki-wasure(ta) "write-forget" → **soo si-wasure(ru)**
- b. tobi-oe(ta) "jump-finish" → **soo si-oe(ru)**

(43) Control complex preds -- Subject Honorification: *o-V1-ni nar*

- a. kaki-wasure(ta) "write-forget" → **o-kaki-ni nari-wasure(ta)**
- b. tobi-oe(ta) "jump-finish" → **o-tobi-ni nari-oe(ta)**

From these considerations, it is clear that Control complex predicates are not lexical compounds, hence analyses along the lines of (38) are untenable.

4. Consequences

In § 1 we have observed various scope facts of complex predicate constructions of V1-V2-Tense type. Then in § 2, we have presented an analysis of them based on a version of three-layered Case theory. In this section, we will discuss several desirable consequences of the proposed analysis.

4.1. Control Predicates without Accusative Case-features

The following example is ambiguous in the same way as the Raising sentences we saw in § 1.1: the object may have either narrow or wide scope with respect to V2 (Yoko Sugioka, personal communication).

(44) Yoko-wa huransu-ryuugaku-tyuu-ni pan-dake-o tabe-nare-ta
Yoko-TOP France-study.abroad-during-at bread-only-ACC eat-get.used.to-PAST

'Yoko got used to eating only bread, while studying in France.'

i) only > get.used.to (It is only bread that Yoko got used to eating while studying in France.)

ii) get.used.to > only (While studying in France, Yoko got used to eating bread without having anything together.)

The sentence when interpreted as i) may imply that Yoko didn't like any food other than bread in France. The sentence in the interpretation ii) may indicate that she was so poor that she couldn't afford anything other than bread. We are tempted to conclude, from this observation, that V2 in this sentence, i.e. *nare* "get used to", is a Raising verb. That this is not correct is shown by the fact that it does not allow inanimate subjects, a characteristic of Control verbs.

(45) *Ame-ga huri-nare-ta
Rain-NOM fall-get.used.to-PAST
 'Rain got used to falling.'

Thus, (44) is a Control sentence that does allow the object narrow scope reading. This is an exception to one of the generalizations we drew in § 1.1, which is repeated below.

- (46) The object in the complex predicate construction obligatorily takes matrix scope if V2 is a Control verb.

Since our analysis presented in § 2.2 is designed to account for (46) among others, the fact that (46) has an exception may seem to pose a problem for the analysis. This is not in fact the case. There is a crucial difference between the Control sentences we considered in § 1.1 on the one hand, and (44) on the other: While V2 in the former (e.g. *wasure* "forget") has an Accusative Case feature, V2 in the latter (i.e. *nare* "get used to") does not. Thus, *wasure* for example takes an accusative object when used as an independent verb, but *nare* cannot do so. *Nare* takes a dative postpositional object instead:¹⁸

¹⁸ There are two types of "dative" particle *ni*: a case marker and a postposition (Sadakane and Koizumi 1995). (i) is an example of the case marker *ni*, and *ni* in (47)c is a postposition.

- (i) Mary-ga John-ni kisusi-ta
 Mary-NOM John-DAT kiss-PAST
 'Mary kissed John.'

An NP with the case marker *ni* may be associated with a floating numeral quantifier as in (ii)a, and may be passivized (at least in some cases) as in (ii)b. An NP with the postposition *ni*, in contrast, cannot be the associate of a floating quantifier, nor does it allow passivization, as shown in (iii).

- (ii) Case marker
 a. ? Mary-ga **gakusee-ni** **3-nin** kisusi-ta
 Mary-NOM **students-DAT** **3-CF** kiss-PAST
 'Mary kissed three students.'
 b. **John-ga** Mary-ni kisu-are-ta
 John-NOM Mary-by kiss-Pass-PAST
 'John was kissed by Mary.'
- (iii) Postposition
 a. * John-ga **sigoto-ni** **3-tu** nare-ta
 John-NOM **job-to** **3-CL** get.used.to-PAST
 'John got used to three jobs.'
 b. * **Sono sigoto-ga** John-ni nare-rare-ta.
 that job-NOM John-by get.used.to-PAST
 Lit. 'That job was gotten used to by John.'

See Sadakane & Koizumi (1995) for a detailed discussion on this topic.

- (47) a. John-ga sigoto-o wasure-ta
John-NOM job-ACC forget-PAST
 'John forgot the job.'
- b. * John-ga sigoto-o nare-ta
John-NOM job-ACC get.used.to-PAST
 'John got used to the job.'
- c. John-ga sigoto-ni nare-ta
John-NOM job-to get.used.to-PAST
 'John got used to the job.'

Recall that, in our analysis, it is the Accusative Case feature of V2 that prevents the object of the Control construction from being Case-licensed in the embedded clause. Thus, the analysis in fact does not predict that (46) holds. Rather it predicts the following.

- (48) The object in the complex predicate construction obligatorily takes matrix scope if V2 has a structural Case feature.

Thus, the ambiguity of (44) is not a problem with our analysis. On the contrary, it confirms the central claim of the analysis, that what forces the object to take matrix scope in the Control sentences we saw in § 1.1 is the Accusative Case feature of V2. In fact, we saw some examples in § 1.2 of Control sentences that have V2 without an Accusative Case feature: the Potential sentences (25)a and (26)a. The potential verb *nare* is a Control verb without Accusative Case features, and the accusative object in the Potential construction takes embedded scope. The following is a list of some Control verbs that behave like *nare* "get.used.to" with respect to Case and scope of the object.

- (49) Control verbs without Accusative Case features
 -*nare* "get.used.to"
 -*tsuke* "be.accustomed.to"
 -*aki* "get.tired.of"
 -*aw* "do to each other"

In short, the ambiguity of the Control sentence in (44) turns out to be a piece of supporting evidence for the proposed analysis rather than a problem.

4.2. Tensed Embedded Clauses

In the complex predicate constructions we have discussed, the Accusative Case-feature of V1 must be copied to the *matrix* T via AGRO for the object to be Case-licensed in the embedded domain. This is because the matrix T is the only T in the construction. We have suggested that in the Control complex predicate construction like (50), the Accusative Case of V1 cannot be copied from the embedded AGRO to the matrix T because of the intervening barrier created by the Control V2 with an Accusative Case feature, and this is the reason why the object of V1 cannot take embedded scope. Then, it is expected that in a construction that is similar to the Control complex predicate construction, but has an embedded T, the Accusative Case-feature of the object of V1 can be copied to the embedded T via the embedded AGRO, hence the object can take embedded scope. This prediction is in fact correct, as shown in (51).

(50) John-wa ringo-dake-o tabe-wasure-ta (= (11))
John-TOP apple-only-ACC eat-forget-PAST

'John forgot to eat only apples.'

i) only > forget (Among many things John was supposed to eat, it is only apples that he forgot to eat.)

ii) *forget > only (It is eat only apples that John forgot to do.)

(51) John-wa [ringo-dake-o tabe-ru no]-o wasure-ta
John-TOP apple-only-ACC eat-PRES that-ACC forget-PAST

Lit. 'John forgot that eats only apples.'

(What John was supposed to do was to eat only apples, but he forgot to do so.)

The example in (50) is a Control sentence without embedded T. As we have seen, the embedded object cannot have embedded scope. The example in (51), on the other hand, is a Control sentence *with* embedded T, and it has an interpretation in which the object takes embedded scope. The English translation given in (50) has the embedded scope for the same reason, i.e. its embedded clause has an infinitive T.¹⁹

¹⁹ That the object of the English examples in (i) may take matrix scope might be due to LF Restructuring analogous to the Restructuring in Japanese discussed in § 2.

- (i) a. John promised to eat only apples. promise > only / only > promise
 b. John forgot to eat only apples. forget > only / only > forget
 (→continue)

4.3. Multiple Embedding

According to the present analysis, Accusative features copied to AGRo can be re-copied to T if that AGRo is in the checking domain of T and there is no intervening category with an original structural Case-feature. This is so regardless of how deeply the AGRo is embedded in the checking domain of T. Thus, suppose that there is a complex predicate sentence with multiple embedding such as (52).

(52) [... [... [... [... [... [... [... OB ... V1] AGRo] V2] AGRo] V3] AGRo] T]

After V raising, we obtain the following partial structure.

(53)

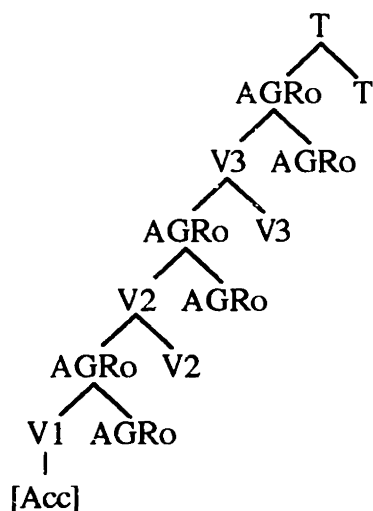

Here, the most deeply embedded AGRo is in the checking domain of T, hence Case-features copied to it from V1 and the object may be copied to T unless V2 or V3 has an original structural Case-feature. Thus, the object in (52) can be Case-licensed within the

c. John expected to eat only apples. expect > only / only > expect

Interestingly, the object wide scope reading is less natural when there is a matrix object, as shown in (ii).

- (ii) a. John promised Mary to eat only apples. promise > only / ??only > promise
 b. John expected Mary to eat only apples. expect > only / ??only > expect

We will leave careful study of the English constructions for future research.

most deeply embedded clause if it moves to the Spec of the AGRO of this clause. If V1 and V2 undergo Restructuring, and the Accusative Case-feature of V1 is transferred to V2 as a result of this process, then the object may be Case-licensed in the Spec of the AGRO in the intermediate clause. If all the three verbs undergo restructuring, the Accusative Case feature of V1 becomes a feature of V3 (or a newly formed complex verb), and then the object may move to the Spec of the matrix AGRO to get Case-licensed. Thus, as long as V2 and V3 do not have their own Accusative Case-features, the object of V1 may be Case-licensed in any of the three clauses. Although it is difficult to construct relevant examples to confirm this prediction (for semantico-pragmatic reasons), the following sentence does seem to be three-way ambiguous with respect to the scope of the accusative object.

- (54) John-wa banana-dake-o tabe-tuzuke-sugi-ta
John-TOP banana-only-ACC eat-continue--overdo-PAST
 'John kept eating only bananas too long.'
 i) only > overdo > continue (Among many things John kept eating, it is only bananas that he kept eating too long a time.)
 ii) overdo > only > continue (John ate several kinds of fruits, among which it was only bananas he kept eating (throughout the relevant time span). John did this too many times.)
 iii) overdo > continue > only (John kept doing the following thing, too long a time: i.e. eating bananas and only bananas.)

A related prediction is that if V2 is a Control verb with an Accusative Case feature, the object cannot have scope within the most deeply embedded clause, but it may take intermediate and matrix scope. Similarly, if V3 is a Control verb with an Accusative Case feature, the object can only take matrix scope. These predictions are indeed correct, as shown by the following examples.

- (55) V2 = Control with [ACC]
 John-wa banana-dake-o tabe-wasure-tuzuke-ta
John-TOP banana-only-ACC eat-forget-continue--PAST
 'John kept forgetting to eat only bananas.'

- i) only > continue > forget (Among many things John forgot to eat, it is only bananas that he kept forgetting to eat (throughout the relevant time span).)
- ii) continue > only > forget (John kept doing the following thing: i.e., "eat everything he is supposed to eat, except that he forgets to eat bananas".)
- iii) * continue > forget > only (John was supposed to do the following thing, i.e. eat only bananas. But he kept forgetting to do so.)

(56) V3 = Control with [ACC]

John-wa banana-dake-o tabe-tuzuke-wasure-ta
John-TOP banana-only-ACC eat-continue-forget-PAST

'John forgot to keep eating only bananas.'

- i) only > forget > continue (John kept eating everything except bananas, which he forgot to keep eating.)
- ii) *forget > only > continue (John was supposed to eat several kinds of fruits, and keep eating only bananas among them throughout the relevant time span. But he forgot to do so.)
- iii) *forget > continue > only (John was supposed to keep doing the following thing: i.e. eat only bananas. But he forgot to do so.)

The above evidence makes a strong case for the proposed analysis of the complex predicate constructions and for the version of three-layered Case theory assumed therein.

4.4. Causative Constructions

In syntactic causative constructions in Japanese, the causee may be marked either with the accusative case marker *o* or the postposition *ni*, as shown in (57).

(57) a. *O*-Causative

Kiyomi-ga Masami-o waraw-ase-ta
 Kiyomi-NOM Masami-ACC laugh-CAUS-PAST
 'Kiyomi made Masami laugh.' (or Kiyomi forced Masami to laugh.)

b. *Ni*-Causative

Kiyomi-ga Masami-ni waraw-ase-ta
 Kiyomi-NOM Masami-to laugh-CAUS-PAST
 'Kiyomi made Masami laugh.' (or Kiyomi allowed Masami to laugh.)

Under the current assumptions, the two types of causative constructions have roughly the following structures, where EC stands for a tenseless embedded clause. For simplicity's sake, head movement is not indicated in the structures ²⁰

- (58) a. *O*-Causative (Raising)
 Kiyomi-ga [AGRoP [VP [EC Masami-o waraw] sase] AGRo] ta
↑ _____
- b. *Ni*-Causative (Control)
 Kiyomi-ga Masami_i-ni [EC PRO_i waraw] sase-ta

This amounts to saying that there are two homophonous causative verbs. The causative verb in the *o*-causative takes two arguments, an agent argument and a clausal argument denoting a caused event, and it has an Accusative Case-feature. The causative verb in the *ni*-causative takes three arguments, Agent, Causee, and Event, and it lacks Accusative Case features. The causee in the *ni*-causative is associated with the postposition *ni*.

- (59) Causative verbs
- a. sase₁: <Agent, Event>
 [Acc]
- b. sase₂: <Agent, Causee, Event>
|
ni (P)

That the *ni*-causative is a control structure is supported by the fact that, the *ni*-marked causee, like the controller in regular control constructions, must be animate, as shown below.

- (60) Ame-ga hut-ta
Rain-NOM fall-PAST
 Lit. 'Rain fell.' (It rained.)

²⁰ Harley (1995) proposes the same analysis.

- (61) a. Raising (Raising to Subject)
 Ame-ga huri-sugi-ta
rain-NOM fall-overdo-PAST
 Lit. 'Rain overfell' (It rained too much.)
- b. Control
 * Ame-ga huri-wasure-ta
rain-NOM fall-forget-PAST
 Lit. 'Rain forgot to fall.'
- (62) a. *O*-Causative (Raising to Object)
 Kiyomi-ga ame-o hur-ase-ta
 Kiyomi-NOM rain-ACC fall-CAUS-PAST
 'Kiyomi caused rain to fall.'
- b. *Ni*-Causative (Control)
 * Kiyomi-ga ame-ni hur-ase-ta
 Kiyomi-NOM rain-to fall-CAUS-PAST

The causee in the *o*-causative is Case-licensed in the matrix domain, as the following passive example indicates, where the causee has been passivized, becoming the surface matrix subject:

- (63) Masami-ga (Kiyomi-ni) waraw-ase-rare-ta
 Masami-NOM (Kiyomi-by) laugh-CAUS-PASS-PAST
 'Masami-was made to laugh (by Kiyomi).'

The "source" of this passive example is not a *ni*-causative sentence. Japanese has case-marker *ni* and postposition *ni* (cf. Sadakane and Koizumi 1995). An NP marked with the case-marker *ni* can be associated with a floating numeral quantifier, and can be passivized, whereas an NP marked with the postposition *ni* allows neither. This is demonstrated below.

- (64) Case marker *ni*
- a. Mary-ga **gakusee-ni** kisusi-ta
 Mary-NOM **students-DAT** kiss-PAST
 'Mary kissed three students.'

- b. ? Mary-ga **gakusee-ni** **3-nin** kisusi-ta
 Mary-NOM **students-DAT 3-CF** kiss-Past
 'Mary kissed three students.'
- c. **John-ga** Mary-ni kisu-are-ta
John-NOM Mary-by kiss-Pass-Past
 'John was kissed by Mary.'

(65) Postposition ni

- a. John-ga (**sono**) **sigoto-ni** nare-ta
 John-NOM (**that**) **job-to** get.used.to-Past
 'John got used to the job.'
- b. * John-ga **sigoto-ni** **3-tu** nare-ta
 John-NOM **job-to** **3-CL** get.used.to-Past
 'John got used to three jobs.'
- c. * **Sono sigoto-ga** John-ni nare-rare-ta.
that job-NOM John-by get.used.to-Past
 Lit. 'That job was gotten used to by John.'

As the following numeral quantifier examples show, the particle *ni* in the *ni*-causative is a postposition .

(66) a. *O*-Causative

Kiyomi-ga **Gakusee-o** **2-ri** waraw-ase-ta
 Kiyomi-NOM **student-ACC 2-CL** laugh-CAUS-PAST
 'Kiyomi made two students laugh.'

b. *Ni*-Causative

* Kiyomi-ga **Gakusee-ni** **2-ri** waraw-ase-ta
 Kiyomi-NOM **student-to** **2-CL** laugh-CAUS-PAST

Thus, the causee in the *ni*-causative cannot be passivized. As a further support for the conclusion that the passive in (63) consists of *sase*₁ not of *sase*₂, consider the semantic difference between the two types of the causatives. As shown by the translations in (57), the *o*-causative such as (57)a has a "forced" interpretation, while the *ni*-causative like (57)b has an "allowed" reading. The passivized causative sentence such as (63) only has the "forced" reading, suggesting that the *o*-causative, but not the *ni*-causative, can be passivized.

Having said this much, let us now consider causatives of transitive verbs. Unlike the cases like (57), where the embedded verb is an intransitive, when the embedded verb is a transitive verb with an accusative object, the causee must be marked with *ni*.

- (67) a. Kiyomi-ga Masami-ni wain-o nom-ase-ta
 Kiyomi-NOM Masami-to wine-ACC drink-CAUS-PAST
 'Kiyomi made Masami drink wine.'
- b. * Kiyomi-ga Masami-o wain-o nom-ase-ta
 Kiyomi-NOM Masami-ACC wine-ACC drink-CAUS-PAST

The example (67)a is ambiguous between the "forced" reading and the "allowed" reading, indicating that the causative verb there may be either *sase*₁ or *sase*₂. On the analogy of the intransitive *o*-causative sentence such as (57)a, one might expect that the causee in the transitive causative construction should be able to bear the accusative *o*. Thus, the ungrammaticality of (67)b might come as a surprise. The impossibility of examples like (67)b has been accounted for by a stipulation to the effect that there should be no more than one *o*-marked phrase within a single clause (the double-*o* constraint) (cf. Harada 1973; Kuroda 1978).²¹

The double-*o* constraint can now be derived from our Case-theory. To see how, let us examine the structures of the transitive causative constructions more closely. Under the current assumptions, one possible structure of (67)a is roughly as follows.

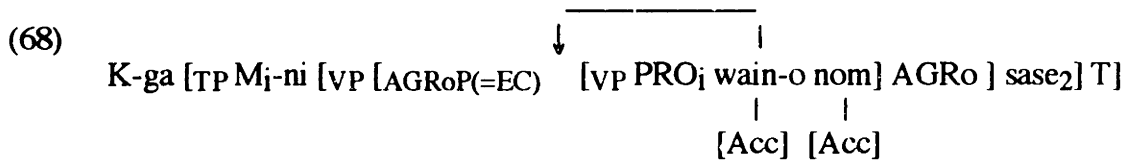

When the embedded verb adjoins to the embedded AGRO, its Accusative Case-feature is copied onto the AGRO. When the embedded object raises to the Spec of the embedded

²¹ The traditional assumption has been that the causative constructions have a mono-clausal structure at the point of derivation relevant to the double-*o* constraint. Under our assumptions, the constraint may be paraphrased as the following.

- i) The double-*o* constraint
 There should be no more than one accusative phrase within a single TP.

AGRo, its Accusative Case-feature is copied onto the AGRo. The pair of Accusative Case-features now in the AGRo will eventually be copied to T when the AGRo is in the checking domain of T. This concludes the process of Case-licensing of the embedded object. Let us next consider the ungrammatical (67)b, which has a structure like (69).

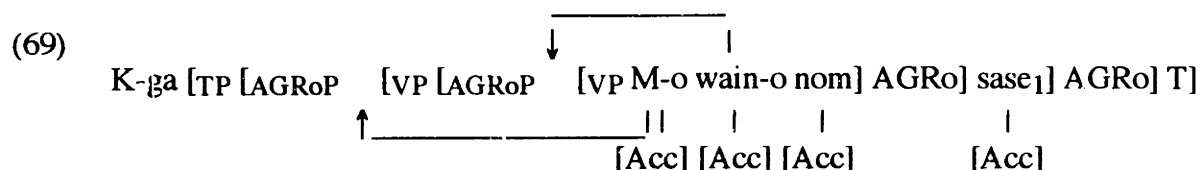

When the embedded verb adjoins to the embedded AGRo, its Accusative Case-feature is copied onto the AGRo. When the embedded object raises to the Spec of the embedded AGRo, its Accusative Case-feature is copied onto the AGRo. So far so good. As a final step of the Case-licensing of the embedded object, the pair of Accusative Case-features copied to the AGRo must be copied to T. This was possible in (68), but the same process is not possible in (69) because of the matrix verb with an Accusative Case-feature, which acts as a barrier for the feature-copying from the embedded AGRo to the matrix T. The example like (67)b is therefore ungrammatical. This is exactly parallel to the situation with the Control constructions in which a Control verb with an Accusative Case-feature prevents the embedded object from being Case-licensed within the embedded domain.

Since the embedded object in the transitive causative construction cannot be Case-licensed in the Spec of the embedded AGRo for the reason just mentioned, it must raise to the Spec of the matrix AGRo, as shown below.

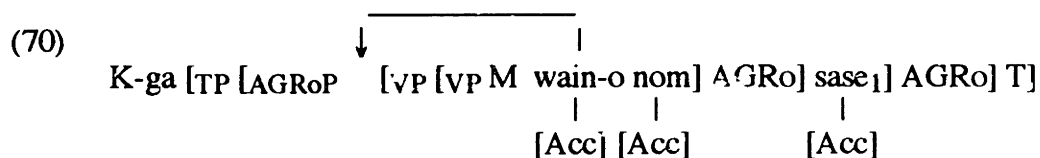

The embedded object in this structure is successfully Case-licensed in the Spec of the matrix AGRo, like the embedded subject in (58)a and the embedded object in the Control constructions. Now, the embedded subject in (70) is Case-less. If nothing happens to it, the structure yields ungrammaticality. However, Japanese has a (possibly language particular) special device which assigns the postposition *ni* to the Case-less embedded subject to save the structure (cf. Takezawa 1987). Thanks to the *ni*-insertion, the transitive causative construction with *sase*₁ is grammatical, giving rise to the surface string identical

to the transitive causative construction with *sase*₂. This is why (67)a above is ambiguous between the "forced" reading and the "allowed" reading.²²

If the Accusative Case-feature of *sase*₁ in the transitive causative construction is absorbed by a passive morpheme, the embedded object can be Case-licensed in the Spec of the embedded AGRO as in (71), because there is no "barrier" for feature-copying any more.

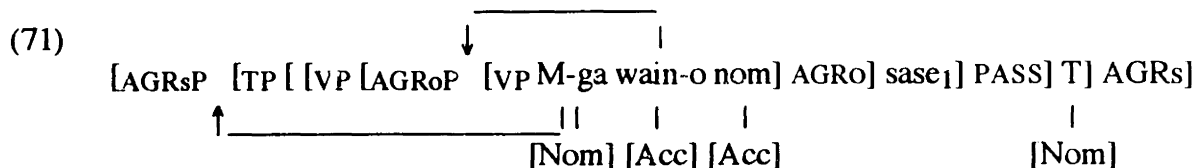

If the embedded subject bears Nominative Case, it can move to the matrix subject position, giving rise to the following passive sentence.²³

- (72) Masami-ga (Kiyomi-niyote) wain-o nom-ase-rare-ta
 Masami-NOM (Kiyomi-by) wine-ACC drink-CAUS-PASS-PAST
 'Masami was forced to drink wine (by Kiyomi).'
 Cf. *'Masami was allowed to drink wine (by Kiyomi).'

This sentence has a "forced" reading but not a "allowed" reading, confirming the above mentioned hypothesis that *sase*₂ cannot be passivized (cf. Kuroda 1965).

²² This account of the double accusative constraint can be extended to the whole class of causative constructions called "reduced causatives" in Watanabe (1992) (e.g. a type of Italian causative), in which the embedded subject is marked with a language specific oblique marker when the embedded verb is transitive.

The claim that *ni* in (67)a is a postposition (rather than a case marker) under both the readings is supported by the fact that the causee cannot be associated with a floating quantifier, as shown in (i) (cf. Sadakane and Kozumi 1995).

(i) * Kiyomi-ga gakusee-ni 3-nin wain-o nom-ase-ta
 Kiyomi-NOM student-to 3-CL wine-ACC drink-CAUS-PAST
 'Kiyomi made three students drink wine.'

²³ For a recent discussion of Japanese passive constructions in general, see Hoshi (1994).

5. Conclusion

In this chapter, we have discussed complex predicate constructions in Japanese, and observed that the embedded object has matrix or embedded scope depending on the Case property of the matrix predicate. The scope facts can be readily explained under our version of Agreement-based Case theory in which AGR_o plays crucial role. The same array of data cannot be naturally accounted for under GB-type analyses in which the object is assigned Case in its base-position. This constitutes strong supporting evidence for the hypothesis that Japanese has Agreement Phrases as characterized in the minimalist framework. It is highly unlikely that Japanese-learning children encounter the kind of data we have discussed. (In fact, I had never heard most of the examples with complex predicates used here until I made them up.) Furthermore, some of the crucial facts (e.g. the absence of the embedded scope reading of the object of Control verbs with an Accusative Case-feature) cannot be accessed without relying on negative evidence. Thus, it is fair to conclude that children do not learn the presence of AGR in Japanese from the type of data we used. Then, unless some evidence for AGR is found that is accessible to Japanese-learning children, we must conclude that Agreement Phrase is universal in the sense that Universal Grammar is construed in such a way that every human language has it.

CHAPTER FIVE

THE SPLIT VP HYPOTHESIS

In Chomsky (1986b), a transitive sentence such as *John cut the orange* was assumed to have a D-structure representation like (1).

- (1) [IP John INFL [vp cut the orange]]

Among the most influential hypotheses proposed since then about the architecture of a clause are the Internal Subject Hypothesis (Fukui and Speas 1986; Kitagawa 1986; Kuroda 1988; Koopman and Sportiche 1991, among others) and the Split Infl Hypothesis (Pollock 1989; Chomsky 1991). According to the ISH, the original position of the subject is VP-internal, as shown in (2).

- (2) [IP INFL [vp John cut the orange]]

Pollock (1989) proposes to "split" Infl into two separate heads, T(ense) and AGR(eement). Chomsky (1991) argues that a single clause contains two (rather than one) Agreement Phrases, i.e. AGRsP and AGRoP, separated by TP:

- (3) [AGRsP [TP [AGRoP [VP]]]]

Most empirical evidence for the ISH cited in literature suggests that there is a position lower than the Spec of IP, associated with the subject.¹ Thus, Sportiche (1988) argues that the "floating" quantifier *all* in (4)a is associated with the trace of the subject, as in (4)b.

- (4) a. The men will *all* cut oranges.
b. The men_i will [[all t_i][cut oranges]]

¹ In my opinion, the strongest argument for the ISH is a conceptual one, to which we will return in § 3.1.

Nakayama & Koizumi (1991) point out that examples of this sort do not bear out the hypothesis that the base-position of the subject is within the VP dominating the verb and the object. The sentences simply indicate that the subject originates in a position lower than its surface position. Nakayama & Koizumi then present several pieces of evidence showing that the subject is "external" in the sense that its base-position is outside the VP, as shown in (5) (cf. Williams 1980, 1981).²

(5) [IP will [XP John X [VP cut the orange]]]

Hale & Keyser (1991; 1993) and Bowers (1993) reached a similar conclusion on independent grounds.

Chomsky's (1991; 1993b) AGRoP analysis raises an interesting question regarding the relative order of AGRoP and the projection XP in (5): Does AGRoP dominate XP as in (6)a, or does XP dominate AGRoP as in (6)b?

- (6) a. [AGRoP AGR [XP John X [VP cut the orange]]]
 b. [XP John X [AGRoP AGR [VP cut the orange]]]

In this chapter, I will argue in favor of the structure (6)b. Particularly, I will present evidence that the base-position of the subject is higher than AGRoP, though lower than TP (and projections of aspectual *have*, *be*, etc.). Thus, *John cut the orange* has roughly the following structure at the point of SPELL-OUT.

(7) [AGRsP John_i [TP [XP t_i cut_v [AGRoP the orange_j [VP t_v t_j]]]]]

The organization of this chapter is as follows. In § 1, I outline our proposal regarding the architecture of verb phrases. It is suggested that XP is a VP, and that the external argument originates in the specifier of this upper VP. This amounts to saying that the original position of the external argument is higher than AGRoP. I call this proposal the SPLIT VP HYPOTHESIS. In § 2, I discuss a set of empirical evidence that motivates the

² We will argue shortly that XP in (5) is the same XP as we discussed in Chapter 2 through Chapter 4.

Split VP Hypothesis. In § 3, I review major arguments brought forth for the standard VP-internal Subject Hypothesis, and show that they are mostly compatible with the Split VP Hypothesis. Finally in § 4, I consider a possibility of eliminating Chomsky's (1993b) domain extension convention given the Split VP Hypothesis. The Appendix provides a brief review of recent literature which shares basic insights with us.

1. A Split VP Hypothesis

We have seen, in the preceding three chapters, that there are (at least) two maximal projections between VP and TP, i.e. AGRoP and XP:

(8) [AGRsP [TP [XP [AGRoP [VP]]]]]

Infl material such as modal *will*, aspectual *have*, *be*, etc. occur between TP and XP. The object and the ECM subject are Case-licensed in the Spec of AGRoP. In this chapter, I address the question of what XP is and what it is for.

Our suggestion is that XP is a VP for the subject: More precisely, the external argument of typical transitive clauses and unergative clauses originates in the Spec of the upper VP, labeled XP in the structure above. Let us call this proposal the SPLIT VP HYPOTHESIS. Abstracting away somewhat, the upper V (V^u) is like an unergative verb such as *laugh* in *Mary laughed*. It typically takes an agentive argument in its Spec (the external argument DP) and an event-denoting argument as its complement (AGRP). The lower V (V^l) is an event-denoting "unaccusative" verb such as *arrive* in *Mary arrived*. A transitive verb such as *open* in *John opened the door* consists of two verbs, a V^u and a V^l , which are spelled out as a single "word" *open*. Thus, *John opened the door* has a structure like (9).

- (9) a. John opened the door.
 b.

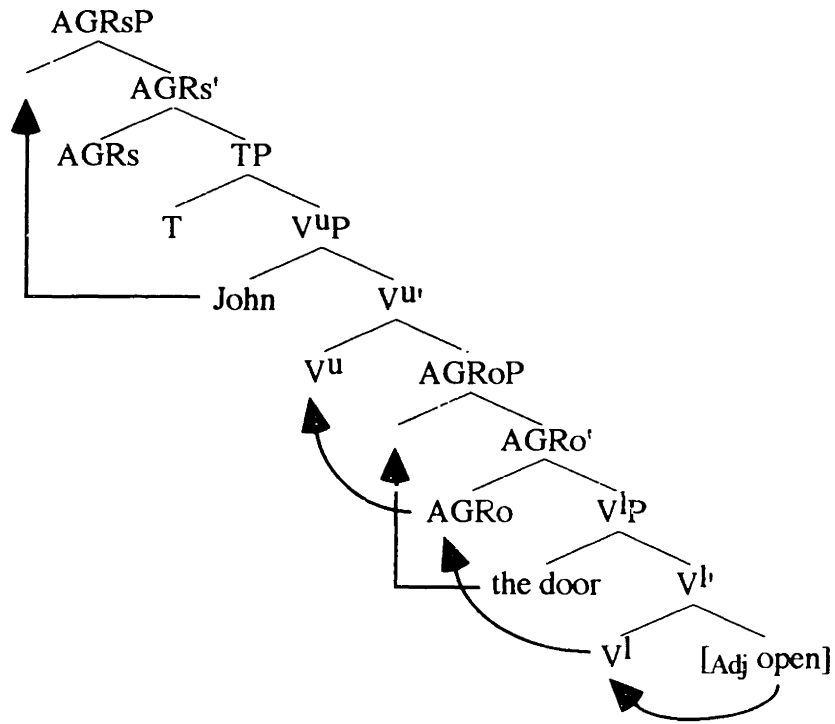

Here I partially adopt Hale & Keyser's (1991; 1993) analysis of de-adjective verbs, according to which *open* starts as an adjective and incorporates into a verb. This particular point, however, is orthogonal to the Split VP Hypothesis, and has no crucial bearing on the following discussion.

Unaccusative *open*, as opposed to transitive *open*, is lacking the upper V. Thus, *The door opened* has a structure like (10).

- (10) a. The door opened.
 b.

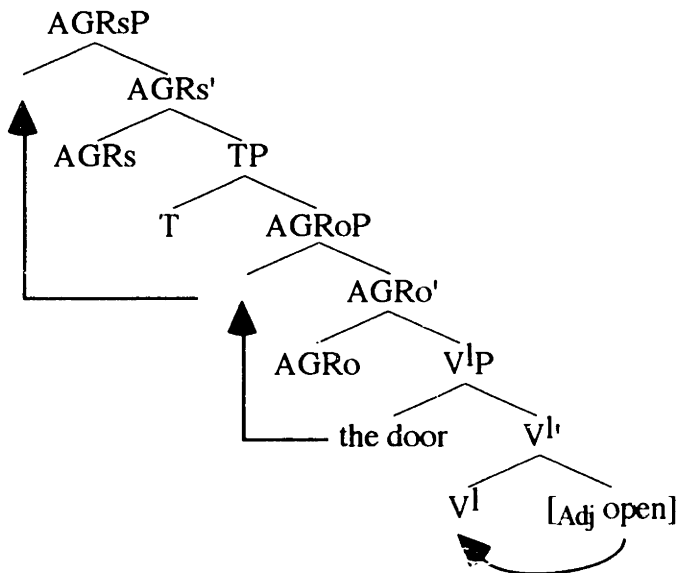

In English, the presence vs. absence of V^u usually has no phonetic reflex. Thus, the transitive *open* assumes the same phonetic form as the unaccusative *open*. In cases like the transitive *raise* vs. the intransitive *rise*, however, the presence vs. absence of V^u is cued overtly. The distinction is more evident in other languages. Thus, we saw in Chapter 3 that V^u is spelled out as *na* in the case of *na*-verbs in Zarma. In Malagasy, it is phonetically realized as *an* (cf. Hung 1988). In Japanese, the presence vs. absence of V^u is signaled differently by various affixes, depending on "classes" of verbs, of which there are approximately sixteen. Some examples, taken from Jacobsen (1992), are given below.

(11) Unaccusative vs. Transitive Oppositions in Japanese

	Unaccusative	Transitive
a.	- \emptyset -	- <i>e</i> -
	ak "open"	ake "open"
	sizum "sink"	sizume "sink"
b.	- \emptyset -	- <i>as</i> -
	nar "ring"	naras "ring"
	tob "fly"	tobas "fly"
c.	- <i>e</i> -	- \emptyset -
	ore "break"	or "break"
	ure "sell, be sold"	ur "sell"

- d. *-ar-* *-e-*
 agar "rise" age "raise"
 hazimar "begin" hazime "begin"

I assume with Hale & Keyser (1991, 1993) that sentences with an unergative verb actually contain two VPs. Thus, under the Split VP Hypothesis, the structure of *John laughed* is essentially as follows.

- (12) a. John laughed.
 b.

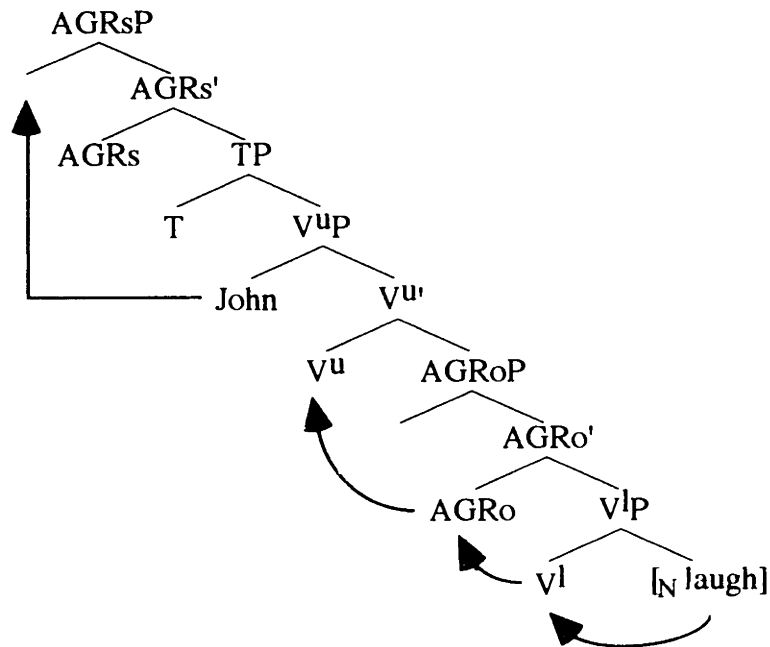

The Split VP Hypothesis receives initial support from the distribution of VP-adverbs shown below.

- (13) a. * [P_oIP Intentionally [P_oIP John will talk to her about it]]
 b. * John [T_P intentionally [T_P will talk to her about it]]
 c. (?) John will [X_P intentionally [X_P talk to her about it]]
 d. (?) John will talk [V_P intentionally [V_P to her about it]]
 e. John will talk to her [V_l intentionally [V_l about it]]

As is generally assumed, a group of adverbs such as *intentionally* (traditionally called VP-adverbs) occur in the VP-area (See Jackendoff 1972 for example). Thus, in (13)d and

(13)e, the adverbs are adjoined to VP and V', respectively. When a VP-adverb adjoins to a projection of a category other than V, the sentence is ungrammatical as illustrated by (13)a-b. If this generalization is correct, the grammaticality of (13)c may be taken to indicate that XP is a VP. The following examples point to the same conclusion.

- (14) a. Aaron [XP/(X')] secretly [XP/(X') gave the ring to her]]
 b. * Aaron gave [AGRoP secretly [AGRoP the ring to her]]
 c. Aaron gave the ring_i [VP/(V')] secretly [VP/(V') t_j to her_j]]

Although the above consideration may not be decisive, it is at least suggestive.

In the next section, I will present evidence that the external argument originates in the specifier of the upper VP (= V^{UP} = XP), in support of the central empirical claim of the Split VP Hypothesis.

2. Motivations for the Split VP Hypothesis

This section discusses motivations for the Split VP Hypothesis.

2.1. Quantifier Float

The first evidence for the Split VP Hypothesis (SVH) comes from the distribution of floating quantifiers. As argued in Sportiche (1988), quantifiers such as *all* may be associated with an NP-trace. Thus, in (15), *all* indicates the original position of the "derived object" and the derived subject.³

³ Maling (1976) observes that floating (stranding) of *all* is possible only if there is a phrase following the quantifier that can be semantically reasonably associated with the NP the quantifier binds: (The examples in this note are all taken from Maling 1976)

- (i) a. * I saw the men all yesterday.
 b. * I found John and Mary and Sue, all.
 (ii) a. I found John and Mary and Sue all sitting on a park.
 b. She had failed her friends all in the same needless way.

I assume with Maling that the constraint in question is semantic in nature, rather than purely syntactic. Floating quantifiers in Japanese discussed below in the text are not subject to such constraint. Floating/stranding of *both* seems to be less restrictive

- (iii) a. I found John and Mary, both.
 b. I visited London and Paris, both.

- (15) a. I gave [AGRoP the books_i [VP all t_i t_v to John]]
 b. The books_i were given [VP all t_i t_v to John]
 c. Becky put the books all on the proper shelf.
 d. The books were put all on the proper shelf.

If the external argument, as well as the internal argument, originates in the VP lower than AGRoP as commonly assumed in literature (the standard Internal Subject Hypothesis), sentences such as (16)d,e and (17)b,c should be grammatical, for the trace of the subject is allegedly adjacent to *all*, as shown in (18) (Recall that, as we have seen in Chapter 2, both the verb and the object/the ECM subject overtly raise in English)

- (16) a. The men all will have given a book to John.
 b. The men will all have given a book to John.
 c. The men will have all given a book to John.
 d. * The men will have given all a book to John.
 e. * The men will have given a book all to John.
- (17) a. The men all believe him to be a liar.
 b. * The men believe all him to be a liar.
 c. * The men believe him all to be a liar.
- (18) The structure of (16)e under the standard ISH: ==> wrong prediction
The men_i will have given [AGRoP a book_j [VP all t_i t_j to John]]

Under the Split VP Hypothesis, on the other hand, this problem does not arise: As shown in (19), the verb is in the head of the upper VP at the point of SPELL-OUT, and the original position of the subject (i.e. the Spec of V^{UP}) is higher than the surface position of the verb, hence there is no trace of the subject below AGRoP.

- (19) The structure of (16)e under the SVH: ==> correct prediction
 *The men_i will have [v^{UP} t_i given [AGRoP a book_j all [v₁P t_j to John]]]

Thus, the examples in (16) and (17) collectively show that the base-position of the external argument is higher than AGRoP, and lower than TP and the projection of aspectual *have*, as is expected from the Split VP Hypothesis.

The same point can be made in Japanese. In Japanese, a numeral quantifier (NQ) may occur either within or outside its host NP. When it is within the host NP, an NQ is

marked with Genitive *no*. When it is outside the host NP, it assumes a "bare form." This is exemplified in (20) (CL stands for a classifier).

- (20) a. NP-internal Numeral Quantifier
 [NP [NQ 3-nin]-no gakusee]-ga piza-o tabeta.
3-CL-Gen students-Nom pizza-Acc ate
 'Three students ate pizza.'
- b. NP-external Numeral Quantifier
 [NP gakusee]-ga [NQ 3-nin] piza-o tabeta.
students-Nom 3-CL pizza-Acc ate
 'Three students ate pizza.'

It is widely assumed that an NP-external NQ and its host NP comprise a constituent, possibly a DP (cf. Kamio 1977; Terada 1990; Kitahara 1992, among others.). This is demonstrated by the following coordination and cleft sentences:⁴

- (21) a. [[Gakusee-ga 3-nin] to [sensee-ga 2-ri]] kita
[[students-Nom 3-CL] and [teachers-Nom 2-CL]] came
 'Three students and two teachers came.'
- b. John-ga [[piza-o 2-kire] to [hanbaagaa-o 1-tu]] tabeta
John-Nom [[pizza-Acc 2-CL] and [hamburger-Acc 1-CL]] ate
 'John ate two slices of pizza and one hamburger.'
- (22) a. Piza-o tabeta no-wa [gakusee-ga 3-nin] da.
Pizza-Acc ate NL-Top students-Nom 3-CL Cop
 'It's three students that ate pizza.'
- b. John-ga tabeta no-wa [piza-o 2-kire] da.
John-Nom ate NL-Top pizza-Acc 2-CL Cop
 'It's two slices of pizza that John ate.'

⁴ See Kitahara (1992) for a proposal concerning the internal structure of [NF-case NQ]. See Miyagawa (1989) and Ueda (1986) for an alternative analysis that NQ and its host NP do not form a constituent, but they are subject to a strict locality condition. The text discussion on the Split VP Hypothesis will remain unaffected if the alternative view turns out to be correct. We will return to this issue in Chapter 7.

In (23)a and (24)a, the NQ and its host NP are separated by an adverb and a dative object, respectively, yet the sentences are grammatical. This (as well as a number of other pieces of evidence) shows that the subject and the direct object in Japanese can overtly move (scramble) to the specifier positions of AGRsP and AGRoP, respectively, "stranding" a numeral quantifier. The structures of the sentences in (23)a and (24)a are given in (23)b and (24)b.

- (23) a. Gakusee-ga kinoo 3-nin piza-o tabeta
students-Nom yesterday 3-CL pizza-Acc ate
 'Three students ate pizza.'
- b. [AGRsP Gakusee-gai [AGRs' kinoo [VP [t_j 3-nin] ...]]]
students-Nom yesterday 3-CL
- (24) a. John-ga piza-o Mary-ni 2-kire ageta
John-Nom pizza-Acc Mary-Dat 2-CL gave
 'John gave two slices pizza to Mary.'
- b. John-ga [AGRoP piza-oi [AGRo' [VP Mary-ni [V' [t_j 2-kire] ...]]]]
John-Nom pizza-Acc Mary-Dat 2-CL

Now, if AGRoP were higher than the base-position of the subject, (25) should be grammatical, since the sentences could have a structure like (26), in which the trace of the subject and the NQ form a constituent.⁵

- (25) a. * Gakusee-ga piza-o 3-nin tabeta
students-Nom pizza-Acc 3-CL ate
 'Three students ate pizza.'
- b. * Huransu-zin-ga hanataba-o 2-ri Mary-ni ageta.
French-people-Nom bouquet-Acc 2-CL Mary-Dat gave
 'Two Frenchmen gave a bouquet to Mary.'
- (26) The structure of (25)a under the standard ISH => wrong prediction
 [AGRsP Gakusee-gai [AGRoP piza-oi [VP [t_j 3-nin] [V' t_j ...]]]]
students-Nom pizza-Acc 3-CL

⁵ See Kuroda (1980; 1983) and Haig (1980) for earlier discussions on sentences like (25).

On the other hand, the Split VP structure correctly rules out (25): as shown in (27), Under the SVH, the trace of the subject and the NQ in (25) cannot be a constituent even if the object undergoes scrambling.⁶

(27) The structure of (25)a under the SVH ==> correct prediction

* [AGRsP Gakusee-ga_i [v_{UP} t_i [AGRoP pizza-oj 3-nin [v_{lP} t_j ...]]]]
students-Nom *pizza-Acc* *3-CL*

Note that, as pointed out in Miyagawa (1989), it is not possible to rule out (25) by postulating a surface filter like (28), because it wrongly bars sentences such as (29).

(28) * NP-ga NP-o NQ

(29) Kinoo, tekihee-ga ano hasi-o 3-nin watatta.
yesterday enemy soldiers-Nom that bridge-Acc 3-CL crossed
 'Yesterday, three enemy soldiers crossed that bridge.'

(adapted from Miyagawa 1989: 41)

The crucial difference between (25) and (29) is that in (25) the subject bears an Agent-role, a typical θ -role for the external argument, whereas in (29) the subject bears a Theme-role, a typical θ -role for the internal argument. Hence, the surface subject in (29) is an internal argument originating in the lower VP (i.e. v_{lP}), thus there is a trace of the subject within v_{lP}, adjacent to the NQ. The sentence is therefore grammatical.

⁶ I assume that the target of scrambling is always a projection of AGR. Thus, the structure (i) in which the object is adjoined to V^{UP} or TP, is impossible.

(i) * [AGRsP Gakusee-ga_i [TP/v_{UP} pizza-oj [TP/v_{UP} t_i 3-nin [AGRoP ... t_j ...]]]]
students-Nom *pizza-Acc* *3-CL*

This assumption about a landing site of scrambling may be derivable from a natural interpretation of Full Interpretation (cf. Chomsky 1994: 31). For example, if some constituent adjoins to a "semantically active" category, say TP, as in (i), a new term of TP is created in addition to the original one. The new TP will remain even if the scrambled category is undone in LF. Of the two terms of TPs, only one receives interpretation as TP, and the other one, being superfluous, is left uninterpreted. This will violate the principle of Full Interpretation. The same problem does not arise when the target of scrambling is a "semantically inert" category such as AGRsP. An adverb may adjoin to a semantically active category because in that case the lower segment is interpreted as a semantic argument of the adverb, and the higher segment receives a usual interpretation.

To summarize, (25), together with (23), (24) and (29), suggests that in Japanese, as in English, the original position of the external argument is higher than AGRoP, as predicted by the SVH.⁷

2.2. Relativized Minimality

In some languages, both the subject and the object (may) move to specifier positions of Agreement Phrases in overt syntax. Icelandic is a case in point (see Jonas and Bobaljik 1993; Collins and Thráinsson 1993, and the references cited therein). We saw in Chapter 2 and Chapter 3 that English and Zarma also belong to this class. Under the standard Internal Subject Hypothesis, such a sentence schematically has a structure like (30).

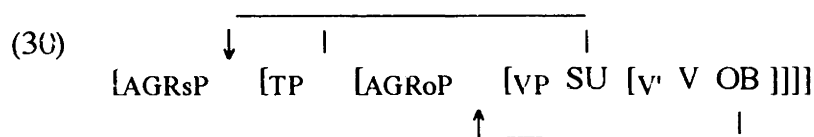

The subject raises to the Spec of AGRs, and the object to the Spec of AGRo. These movements are motivated by morphological reasons such as checking of NP-features and V-features. Two questions arise: (i) Why is it possible for the object to move past the subject in the Spec of V (A-Specifier), apparently violating Relativized Minimality (RM) of Rizzi (1990) (or Minimal Link Condition (MLC) of Chomsky and Lasnik 1993)?⁸ Similarly, why is it possible for the subject to move past the object in the Spec of AGRo? (ii) If movement across A-specifiers is possible as in (30) why is it not possible for the object to go to the specifier of the higher AGR, as in (31)?

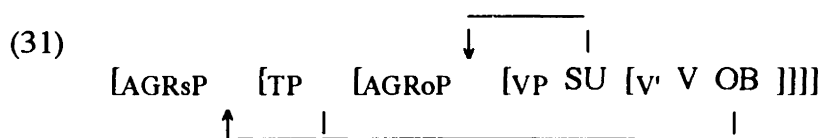

⁷ There are languages in which sentences superficially similar to (25) are acceptable. In § 3.5, we will argue that such sentences are not counterexamples to the SVH.

⁸ The same problem arises in Chomsky's (1993b) analysis of LF object shift in English and other languages.

By way of answering these questions, Chomsky (1993b) suggests sharpening the notion of "distance" relevant to RM/MLC as in (32).

(32) If α , β are in the same minimal domain, they are equidistant from γ .

Given this, the Spec of AGRo and the Spec of V are equidistant from the position of the object, after V adjoins to AGRo as in (33)a. Thus, if the object raises to the Spec of AGRo, it does NOT count as crossing the Spec of V.

(33) a. [AGRoP V-AGRo [VP SU t_v OB]]]
 \uparrow _____ |
 \Downarrow
 b. [AGRsP V-AGRo-T-AGRs [TP t_t [AGRoP OB_i t_{agr} [VP SU t_v t_i]]]]
 \uparrow _____ |

After the movement of AGRo-V to T, the Spec of T and the Spec of AGRo are equidistant from the original position of the subject, hence the subject can raise to the Spec of AGRs through the Spec of T without violating the Relativized Minimality condition as adapted in Chomsky (1993b) (RM/MLC). (31) is still impossible because the object movement to the Spec of T crosses the Spec of V, which is not equidistant with the Spec of T from the base-position of the object, in violation of RM/MLC.

We can appeal to the same mechanism to ensure that the two objects in the double object construction raise to the correct positions: the Goal object to the Spec of AGRio, and the Theme object to the Spec of AGRo:⁹

(34) _____ |
 \downarrow
 [AGRioP [AGRoP [VP Goal Theme]]]
 \uparrow _____ |

After V adjoins to AGRo, the Spec of AGRo and the Spec of V are equidistant from the original position of the Theme object. Thus, the Theme object may raise to the Spec of _____

⁹ In § 4 I discuss an alternative to (34) which would allow us to dispense with (32) entirely.

AGRo past the Goal object in the Spec of V. After the AGRo-V complex adjoins to AGRio, the Spec of AGRio and the Spec of AGRo are equidistant from the VP-internal positions. Hence, the Goal object can move to the Spec of AGRio, skipping the Spec of AGRo. The derivation analogous to (31) is not possible for the same reason as (31) is impossible. In general, movement skipping two or more specifier positions of different heads is not possible (unless "excorporation" head movement is allowed).

Now, if the subject is generated within the VP dominated by AGRoP as is commonly assumed, the double object construction should have a structure like (35).

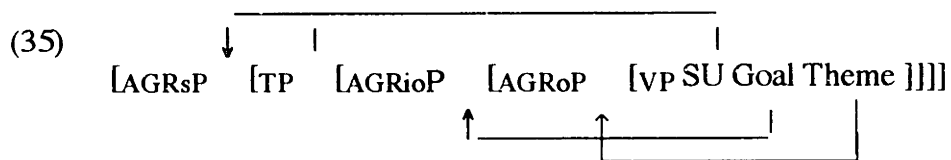

Here, the subject crosses the Spec of AGRio and the Spec of AGRo, the latter of which is not equidistant with the Spec of T from the original position of the subject. Similarly, the Goal object crosses the Spec of AGRo and the Spec of V. The Spec of V, of course, is not equidistant with the Spec of AGRio from the original position of the Goal object. (35) is, therefore, a violation of RM/MLC. Nevertheless, the double object constructions are grammatical in many languages including English, Zarma, and Icelandic (cf. Chapter 2 and Chapter 3, see Collins and Thráinsson 1993 for Icelandic). This strongly indicates that the subject in fact originates in a position higher than AGRoP and AGRioP, as shown in (36).¹⁰



This is what we expect under the Split VP Hypothesis, but is problematic under the standard Internal Subject Hypothesis.

There is a more serious problem with the standard Internal Subject Hypothesis with respect to RM/MLC. We saw in Chapter 3 that Zarma transitive sentences with a *na* verb

¹⁰ For this very reason, Collins and Thráinsson (1993) propose a biclausal analysis of the DOC similar to our Split VP analysis.

have a partial structure like (37)b. Structures like (37)b have been proposed and defended for other languages as well (Mahajan 1990 for Hindi; Bobaljik 1992 for Inuit; Bobaljik and Carnie 1994 for Irish, to name just a few).

- (37) a. a na hansoo kar.
 he NA the dog beat
 'He beat the dog.'
- b. ... [AGRoP hansoo_i kar_j [VP t_j t_i]
 the dog beat

The problem with this analysis is that, since the verb raises only to AGR_o in overt syntax, if the original position of the subject is within the VP lower than AGR_oP as in (38) below, the subject should not be able to raise past the object in the Spec of AGR_o because of RM/MLC.

- (38) ... [SU_i [AGRoP OB_m [AGR V_j AGR] [VP t_i t_j t_m]]]

Thus, the grammaticality of sentences with structure like (37)b suggests that the subject originates in a position higher than AGR_oP. This is then another piece of evidence in favor of the Split VP Hypothesis over the standard Internal Subject Hypothesis.¹¹

2.3. Participle Agreement

As we have seen in § 5 of Chapter 2, participles in French agree with their derived subject such as the surface subject of a passive sentence or an unaccusative sentence. The relevant examples are repeated below.

¹¹ Incidentally, Chomsky's (1993b) version of RM/MLC, together with the Split VP Hypothesis, provides a plausible answer to the question of why the number of internal arguments is limited to maximally two (cf. Hale and Keyser 1991; 1993). As we have seen above, at most two arguments may A-move out of a VP. Therefore, if three or more NPs occur in the lower VP, one of them has to remain in the VP. This leads to a Case Filter violation (or its equivalent in the minimalist framework) unless it is Case-licensed VP-internally by some special mechanism (e.g. applicative constructions in Bantu languages, cf. Marantz 1993).

- (39) a. Les livres de Jules Verne ont tous été imprimés/*imprimé.
the books of have all been published
- b. Ils sont déjà partis/*parti.
they are already left

Based on a series of work by Kayne (e.g. Kayne 1985b; 1989), Chomsky (1991) suggests that the participle agreement occurs because, when an NP moves from a VP-internal position to the Spec of AGRs, it does not move in one fell swoop, rather it moves through the Spec of AGRo, as shown in (40).

- (40) [AGRsP ... [AGRoP [VP... NP ...]]]
 <-----|↑-----|

A participle does not agree with external arguments such as the subject of a transitive sentence or an unergative sentence, as shown in (41) (Kayne 1985b).

- (41) a. Jeanne a repeint/*repeinte la table.
have repainted the table
- b. Ils ont ri/*ris.
they have laughed

If the subjects in these examples originated in a position lower than AGRoP, the participles should bear overt agreement features. For this reason, Kayne (1985b), following Hoekstra (1984), suggests that these subjects are base-generated in the specifier of aspectual *have* (*avoir* in French), where they receive their θ -roles from *have/avoir*. However, as pointed out in Branigan (1992), this analysis is problematic in several respects. To mention just one, a floating quantifier associated with the subject may occur to the right of aspectual *have*:

- (42) The men will have *all* finished their work by then.

Assuming Sportiche's (1988) theory of quantifier floating, (42) indicates that the subject's original position is lower than (the specifier of) *have/avoir*, contrary to Kayne's analysis.

The Split VP Hypothesis can accommodate both the facts about participle agreement and the facts about quantifier floating. Under the SVH, the subject of a transitive clause

and an unergative clause originates in the specifier of the upper V (V^u). Since V^u is outside AGRoP, the subject need not, in fact cannot, stop by at the Spec of AGRo. Thus, there is no participle agreement with external arguments. At the same time, the Spec of V^u is to the right of (i.e. lower than) *have/avoir*, hence floating quantifiers may follow them.¹²

2.4. Chain Condition

The final piece of evidence for the Split VP Hypothesis to be discussed here comes from Rizzi's Chain Condition. As required by Condition A of the Binding Theory, the Japanese reciprocal *otagai* 'each other' has to be locally bound. If *otagai* is not c-commanded by its intended antecedent, the sentence is ungrammatical, as shown in (43)b. The sentence will become grammatical if the antecedent NP scrambles to the sentence-initial position, from which it can c-command the reciprocal. This is shown in (43)c (cf. Saito 1992; Tada 1993).

- (43) a. John to Bill-ga otagai-no sensee-o hihansita.
John and Bill-Nom e.o. -Gen teacher-Acc criticized
 'John and Bill criticized each other's teachers.'
- b. * Otagai-no sensee-ga John to Bill-o hihansita.
e.o. -Gen teacher-Nom John and Bill-Acc criticized
 'Each other's teachers criticized John and Bill.'
- c. John to Bill-o_i otagai-no sensee-ga t_i hihansita.
John and Bill-Acc e.o. -Gen teacher-Nom criticized
 'John and Bill, each other's teachers criticized.'

In these sentences, *otagai* is a part of an argument. When *otagai* is an argument by itself, a different picture emerges. Compare (44) with (43).

- (44) a. John to Bill-ga otagai-o hihansita.
John and Bill-Nom e.o. -Acc criticized
 'John and Bill criticized each other.'

¹² Sportiche (1990) contains a similar argument.

- b. * Otagai-ga John to Bill-o hihansita.
e.o. -Nom John and Bill-Acc criticized
 'Each other criticized John and Bill.'
- c. * John to Bill-o_i otagai-ga t_i hihansita.
John and Bill-Acc e.o. -Nom criticized
 'John and Bill, each other criticized.'

(44)a, like (43)a, is a typical example of a grammatical sentence with a reciprocal. (44)b, as (43)b, violates Condition A. In (44)c, as in (43)c, 'John and Bill' locally binds *otagai*, satisfying Condition A. Thus, (44)c should be as grammatical as (43)c, contrary to fact.

The ungrammaticality of (44)c is readily accounted for by the Chain Condition, originally proposed in Chomsky (1981:333) and modified by Rizzi (1986: 66) as (45) (see Snyder 1992 for an application of this condition to various languages).

(45) Chain Condition

$C = (a_1 \dots a_n)$ is a chain iff, for $1 \leq i < n$, a_i is the local binder for a_{i+1} .

For 'John and Bill' and t_i in (44)c to form a chain, 'John and Bill' has to be the closest binder for t_i . However, this is not the case, because there exists a closer binder *otagai*, between 'John and Bill' and t_i . The sentence thus violates the Chain Condition, hence ungrammatical. (43)c does not have this problem, as *otagai* does not c-command t_i in this sentence.¹³

¹³ (ia) is acceptable for many speakers of English, and (ib) for all speakers.

- (i) a. John seems to himself to be clever.
 b. They seem to each other to be clever.

It seems that morphologically complex anaphors are immune to the Chain Condition. See Rizzi (1986) for discussion. Japanese *otagai* 'each other' is morphologically simplex except that the polite marker *o-* is attached to the stem *tagai*.

The same point can be made by using indirect and direct objects, as demonstrated in (46) and (47). The (b) sentences are derived from the corresponding (a) sentences by scrambling the direct object across the indirect object.¹⁴

- (46) a. ?* Mary-ga otagai-no atarasii sensee-ni John to Bill-o syookaisita.
Mary-Nom e.o. -Gen new teacher-Dat John and Bill-Acc introduced
 'Mary introduced John and Bill to each other's new teachers.'

¹⁴ Some speakers accept (47)b. Miyagawa (1995a) argues that such idiolects allow, in addition to the structure in (47)b, the structure in (i) in which the base-position of the Theme object is higher than that of the Goal object.

- (i) Mary-ga [vp John to Bill-o [v' otagai-ni t_v]] syookaisita.
Mary-Nom John and Bill-Acc e.o. -Dat introduced

According to Miyagawa, the dative Goal phrase is an NP (or a DP) when its base-position is higher than the accusative Theme object, whereas it is a PP when it is base-generated next to the verb. This is consistent with the thematic hierarchy assumed in this thesis, repeated here as (ii).

- (ii) Agent > Affected Goal > Theme > Unaffected Goal

Affected Goal role is assigned to the first DP object in the double object construction such as (iiia), for example. Unaffected Goal role, in contrast, is assigned to the PP in the dative construction such as (iiib) (cf. note 23 of Chapter 2).

- (iii) a. John gave Bill a watch.
 b. John gave a watch to Bill.

See also Sadakane & Koizumi (1995) for a detailed discussion on the dative DP and the dative PP in Japanese.

Miyagawa (1995b) further observes that even those who accept the Japanese example in question reject (ivb) with the indicated interpretation.

- (iv) a. ? Mary-ga gakusee-o otagai-no sensee-ni t_i 2-ri syookaisita.
Mary-Nom student-Nom e.o.-Gen teacher-Dat 2-CL introduced
 'Mary introduced two students to each other's teachers.'
 b. * Mary-ga gakusee-o otagai-ni t_i 2-ri syookaisita.
Mary-Nom student-Nom e.o.-Dat 2-CL introduced
 'Mary introduced two students to each other.'

In (iv), the floating numeral quantifier signals the presence of the trace of the accusative object c-commanded by the dative object, which in turn yields a violation of the Chain Condition in (ivb).

- b. Mary-ga John to Bill-o_i otagai-no atarasii sensee-ni t_j syookaisita.
Mary-Nom John and Bill-Acc e.o. -Gen new teacher-Dat introduced
- (47) a. * Mary-ga otagai-ni John to Bill-o syookaisita.
Mary-Nom e.o. -Dat John and Bill-Acc introduced
 'Mary introduced John and Bill to each other.'
- b. ?* Mary-ga John to Bill-o_i otagai-ni t_j syookaisita.
Mary-Nom John and Bill-Acc e.o. -Dat introduced

(46)a and (47)a are in violation of Condition A, while (46)b and (47)b satisfy the condition. Unlike (46)b, (47)b fails to conform to the Chain Condition: *t_j* is locally bound by *otagai* with an independent θ -role, rather than by 'John and Bill'. The passive cases below further exemplify this point.¹⁵

- (48) a. * Otagai-no sensee-ga John to Bill-o nagutta
e.o.-Gen teacher-Nom John and Bill-Acc hit-Past
 'Each other's teachers hit John and Bill.'
- b. John to Bill-gaj otagai-no sensee-niyotte t_j nagur-are-ta
John and Bill-Nom e.o.-Gen teacher-by hit-Pass-Past
 'John and Bill were hit by each other's teachers.'
- (49) a. * Otagai-ga John to Bill-o nagut-ta.
e.o.-Nom John and Bill-Acc hit-Past
 'each other hit John and Bill.'

¹⁵ Like many adpositions, *niyotte* does not prevent the NP it attaches to from c-commanding a constituent outside the PP. Thus, in (i) *kare* 'he' c-commands *John*, yielding a Condition C violation.

- (i) * Mary-ga kare_j-niyotte John_j-no okusan-ni syookai-sare-ta
Mary-NOM he-by John-GEN wife-to introduce-PASS-PAST
 Lit. 'Mary was introduced by him_j to John_j's wife.'

Mamoru Saito (personal communication) notes that the ungrammaticality of the following unaccusative example may also be due to a violation of the Chain Condition.

- (ii) * Gakusee-gaj otagai-ni t_j 2-ri butukatta.
students-NOM e.o.-DAT 2-CL bumped
 'Two students bumped into each other.'

Here the NQ is used to force the non-agentive unaccusative interpretation.

- b. * John to Bill-gai otagai-niyotte t_i nagur-are-ta.
John and Bill-Nom e.o.-by hit-Pass-Past
 'John and Bill were hit by each other.'

Now consider the following examples.

- (50) a. John to Bill-ga Mary-ni otagai-o syookaisita.
John and Bill-Nom Mary-Dat e.o.-Acc introduced
 'John and Bill introduced each other to Mary.'
- b. John to Bill-ga otagai-o_i Mary-ni t_i syookaisita.
John and Bill-Nom e.o.-Acc Mary-Dat introduced

In (50)b, *otagai* has been scrambled to the Spec of AGR_o. Under the standard ISH, this sentence has the structure in (51).

- (51) The structure of (50)b under the standard ISH ==> wrong prediction
 [AGR_{sP} John and Bill_i ... [AGR_{oP} otagai_j ... [VP t_i...t_j...]]

(51) is essentially the same structure as (44)c, (47)b, and (49)b in relevant respects, with *otagai* intervening between 'John and Bill' and its trace *t_i*. Thus, if the structure in (51) were correct, (50)b should be as ungrammatical as (44)c, (47)b and (49)b, an obviously wrong prediction. On the other hand, if the base-position of the subject is higher than AGR_{oP}, the acceptability of (50)b is not a problem, since the sentence will have the structure in (52), which obeys the Chain Condition as well as Binding Condition₃.

- (52) The structure of (50)b under the SVH ==> correct prediction
 [AGR_{sP} John and Bill_i ... [VP t_i... [AGR_{oP} otagai_j ... [VP...t_j...]]]

Thus, the fact that (50)b is perfectly acceptable is another piece of supporting evidence for the SVH.

3. Arguments for the Internal Subject Hypothesis Revisited

We have seen that the Split VP Hypothesis has a number of empirical and theoretical advantages over the standard Internal Subject Hypothesis. In this section, we consider if and how the arguments presented in the literature for the standard Internal Subject Hypothesis can be accommodated under the Split VP Hypothesis.

3.1. Simplification of θ -marking

One advantage of the Internal Subject Hypothesis over the traditional view that the subject is outside the VP throughout the derivation, is that it simplifies the way θ -roles are assigned. That is, under the Internal Subject Hypothesis, all θ -roles, including the one for the "external argument", are assigned uniformly under the sisterhood relation with projections of the verb. Under the traditional view, on the other hand, something special has to be said about the θ -marking of the subject. This conceptual motivation for the ISH, which seems to be shared by most proponents of it, is explicitly stated in Fukui (1986) with a detailed discussion of problematic aspects of θ -marking in the traditional way.

The idea that all arguments of a verb are generated within its maximal projection, is not only *compatible* with, but also one of the core assumptions of, the Split VP Hypothesis. Recall that the logic of our arguments for the Split VP Hypothesis is as follows: There is evidence that the base-position of the subject is higher than AGRoP, which in turn dominates the base-positions of the verb and the object. *If all arguments of a verb are generated within the maximal projection of the verb*, then there must be two separate verbs within a clause, one for the subject above AGRoP, and one for the object below AGRoP.¹⁶ In this sense, the Split VP Hypothesis is *not* an alternative to the ISH, but rather is a new proposal about clause architecture *based on* the ISH.

3.2. INFL as a Raising Category

Raising verbs such as *seem* are so called because their surface subjects are supposed to be raised from the subordinate clause, as shown in (53).

¹⁶ One might say that the postulation of two verbs in a single clause is counterintuitive. However, speakers of a language do not have intuitions about their grammar. They only have some judgments arising from interactions of various components of their cognitive system, the grammar being one of them. Thus non-linguists do not have "intuitions" as to whether *speaks*, for example, is one lexical item (V) or two (V+AGR). It is a theory that determines it.

(53) John_i seems [t_i to sleep all the time]

Seem is traditionally analyzed as raising verb for the following reasons.

- (54) i. *seem* imposes no selectional restrictions on its subject;
ii. *seem* can take expletive *it* as subject (*it seems that John sleeps all the time*) or non-expletive subjects as in (53).
iii. *seem* allows as its subject an NP licensed by the predicate of the clause embedded under it:

weather *it* (*it seems to rain a lot*)

idiom chunks (*the cat seems to be out of the bag*)

existential there (*there seems to be a griffin on the 22nd level*)

(adapted from Koopman and Sportiche 1991)

These properties indicate that *seem* does not assign an external θ -role. Koopman & Sportiche (1991) point out that those elements that occur in the INFL area such as modals (e.g. *will*) and auxiliaries (e.g. aspectual *have*) have most of these properties.

- (55) i. *will* does not assign an external θ -role;
ii. *will* allows as subject an NP licensed by the predicate of the clause embedded under it:

weather *it* (*it will rain*)

idiom chunks (*the cat will be out of the bag*)

existential there (*there will be a griffin on the 22nd level*)

(adapted from Koopman and Sportiche 1991)

From this, Koopman & Sportiche (1991) conclude that INFL elements such as *will* are raising categories, hence their surface subjects originate within their complements (their v_{max}), as in (56).

(56) John_i will [t_i win the race]

This aspect of the Internal Subject Hypothesis is crucially incorporated into the Split VP Hypothesis, as is evident from (57).

(57) John_i will [_{VP} t_i win_v [_{AGROp} the race_j [_{VP} t_v t_j]]]

Thus, the INFL-as-a-raising-category argument is an argument for both the standard ISH and the Split VP version of the internal subject hypothesis, i.e. the SVH.

3.3. VP Coordination

VP coordination sentences such as (58)a have been a long standing problem for theories of coordination and extraction.

- (58) a. The boys will [[write a book] and [be awarded a prize for it]]
b. The boys_i will [[write a book] and [be awarded t_i a prize for it]]

Under the traditional analysis in which the external argument is base-generated in the Spec of Infl, (58)a has a structure like (58)b, in which only one of the two coordinates contains a trace bound by the surface subject. This structure is problematic at least in two respects. First, it violates the Coordinate Structure Constraint, which prevents movement from one conjunct in a coordinate structure, unless movement also occurs from the other conjunct (Ross 1967; Williams 1977b; 1978). Second, in this structure, the surface subject position has to be a θ - and a θ -bar position simultaneously, since the first conjunct (active VP) requires that the Spec of Infl be a θ -position, while the second, passive, VP requires that it be a θ -bar position. Burton & Grimshaw (1992) and McNally (1992) suggest that these problems will be solved if we adopt the ISH. Under the ISH, (58)a will have an "S-structure" representation like (59), in which both coordinates contain a trace of the subject.

- (59) The boys_i will [[t_i write a book] and [be awarded t_i a prize for it]]

This structure obeys the CSC, and it does not have the θ/θ -bar conflict because, under the ISH, the Spec of Infl is uniformly a θ -bar position. The VP coordinate sentences such as (58)a therefore can be considered a piece of supporting evidence for the ISH, Burton & Grimshaw (1992) and McNally (1992) argue.

As some readers may have noticed, this argument again does not tell apart the standard ISH and the SVH, because under the latter hypothesis, each of the two conjuncts in (58)a involves our upper VP (V^{UP}), which contains a trace of the surface subject, as shown in (60).

(60) The boys_i will [[_{VP} t_i write a book] and [be [_{VP} awarded t_i a prize for it]]]

3.4. Reconstruction Effects

In (61)a, the reciprocal can be construed either with the matrix subject or with the embedded subject. This suggests that the fronted NP may be "reconstructed" either to the intermediate trace position (t_i'), or to the trace in the embedded clause (t_i).

- (61) a. [_{NP} Which friends of each other]_i did they say t_i' that we should talk to t_i?
b. [_{VP} Talk to friends of each other]_i, they said t_i' we should not t_i.

(adapted from Huang 1993)

In (61)b, on the other hand, the reciprocal can only be construed with the embedded subject (cf. Barss 1986). Since we know, from (61)a, that the fronted constituent can be "reconstructed" to its intermediate trace position, the unambiguity of (61)b is somewhat mysterious. Huang (1993) suggests that facts like these have a straightforward explanation under the ISH. Given the ISH, the "S-structure" representation of an English sentence contains a trace of the subject in the VP. When the VP is fronted as in (61)b, the subject trace is fronted with it. Thus, whichever trace position the VP is reconstructed to, the VP-internal subject trace is always the local binder of the reciprocal. The sentence is therefore unambiguous (see also Takano 1995).

The same story can be told within the Split VP Hypothesis, because, given the SVH structure of English, what is fronted in (61)b is V^{UP}, which contains a trace of the subject. Besides, there is a plausible alternative analysis of this contrast by Barss (1986) that does not rely on VP-internal subject traces.¹⁷

3.5. Quantifier Float

Probably the most well-known argument for the ISH is the one given in Sportiche (1988), based on the distribution of floating quantifiers. We have already seen, in § 2.1, that the facts about quantifier floating in fact favor the SVH over the standard ISH. To repeat a relevant example, the ungrammaticality of (62) shows that there is no subject trace below AGRoP.

¹⁷ See Barss (1986: 203ff.) for details of his Chain Binding account of the contrast in (61), based on his theta-compatibility requirement.

- (62) *Gakusee-ga [AGRoP piza-oi [VP 3-nin ti tabeta]] (cf. (25))
students-Nom pizza-Acc 3-CL ate
 'Three students ate pizza.'

As has been noted by many researchers, however, there is conflicting evidence (Déprez 1989; Speas 1991; Jonas and Bobaljik 1993, to name just a few) Consider the following sentences.

- (63) a. Navajo (Speas 1991)
Diné dibé t'óó 'ahayóí bee dahóló
Navajo sheep many to-them have
 'Many Navajos have sheep.'
- b. Icelandic (Jonas and Bobaljik 1993)
 Í gær máluðu strákarnir húsið allir rautt
yesterday painted the.boys the.house all red
 'Yesterday all the boys painted the house red'

Speas (1991) and Jonas & Bobaljik (1993) argue that these sentences have a structure like (64), supporting the ISH.

- (64) SU_i [AGRoP OB_j [VP [Q t_i] t_j]]

This argument is simple, hence it is potentially a very strong argument for the standard ISH. However, there are alternative analyses of the examples like (63).

One possibility is that floating quantifiers in languages like Navajo and Icelandic are different from those quantifiers that fall under Sportiche's theory. The analysis in (64) crucially assumes that *t'óó* 'many' and *allir* 'all' must be adjacent to the trace of their host NPs at the point of SPELL-OUT. However, this assumption is not necessarily warranted. If these quantifiers belong to the type of quantifiers that do not require adjacency to their hosts or their traces in overt syntax, then the sentences like (63) do not prove that there is a subject trace below AGRoP. In this connection, the following point is suggestive. Korean has two types of floating numeral quantifiers (NQ). One type of NQ consists of a numeral and a classifier (Num-CL), and the other type, a numeral, a classifier, and a case marker (Num-CL-Case). The first type of NQs are like those in Japanese in that they underlyingly form a constituent with their host NPs, hence whenever they are separated from their host

NPs, they are associated with a trace of the hosts. The second type of NQs, on the other hand, do not form a constituent with their host NPs (in overt syntax), and they have freer distributions than those in the first group.¹⁸ Thus, quantifiers of the first type, when associated with the subject (trace), may not occur to the right of the object (65)a (cf. Japanese (62) above), but quantifiers of the second type can (65)b¹⁹.

- (65) a. * Haksayng-i chayk-ul seu-myeng saessta
students-Nom book-Acc three-CL bought
 'Three students bought a book.'
- b. Haksayng-i chayk-ul seu-myeng-i saessta
students-Nom book-Acc three-CL-Nom bought
 (same as above)

If the floating quantifiers in Navajo and Icelandic are like the second type of quantifiers in Korean (or ambiguous between the first and the second type), the sentences in (63) are on a par with (65)b and hence uninformative about the base-position of the subject.

Another conceivable analysis of (63) is that in languages like Navajo and Icelandic, there is another AGR type projection above V^{UP}, as shown in (66).

- (66) [AGRS_P SU_i [TP t_i' [AGRO_P OBJ [V^{UP} [Q t_i] [AGRO_P t_j' [V_{IP} t_j]]]]]]

If so, in these languages, subject-oriented quantifiers may occur to the right of the object at the point of SPELL-OUT, as in (63).

4. Can the Domain Extension Convention Be Eliminated?

In Chomsky (1993b), the domain of a head X is first defined as everything dominated by (a segment of) its maximal projection XP. The definition is later modified so that, when X raises to the next head up, say Y, the domain of X extends to include everything dominated by (a segment of) YP. There are two motivations for this domain

¹⁸ It may be that the second type of NQs adjoin to their host NPs in LF for the purpose of Case-(and/or ϕ -feature) licensing (Mamoru Saito, personal communication).

¹⁹ Thanks to Keun-Won Sohn for help with the examples in (65).

extension convention. First, in Chomsky's (1993b) Case theory, the object NP is Case-checked in the Spec of AGRo by V. According to his first definition of the domain, however, the Spec of AGRo is not in the checking domain of V, hence V cannot enter into the checking relation with the object there. Under the revised definition, the Spec of AGRo is in the checking domain of V after V adjoins to AGRo, thus the desired checking relation can be established. Second, he assumes a clause structure in which the object has to cross the subject or its trace on its way to the Spec of AGRo. This movement violates Relativized Minimality as proposed in Rizzi (1990), thus it should be ruled out. To solve this problem, Chomsky proposes the notion of equidistance given in (32) above, which does the intended job only under the revised definition of the domain.

Given the theory of Case and phrase structure developed in this thesis, the motivation for the domain extension convention is significantly weakened. It is unnecessary for the purpose of Case checking if we adopt the Case theory suggested in § 4 of Chapter 2, in which Case-checking between the object and the verb is done by copying the Case-features of the object and the verb onto AGRo. In this theory, the object and the verb do not enter into the checking relation directly, rather they *effectively* enter into checking relation by both being in the checking domain of AGRo. Furthermore, given the Split VP structure, the domain extension convention plays no role in allowing the movement of the object to the Spec of AGRo in a mono-transitive sentence. The only place we seem to need the convention is the double object construction. In the analysis of the DOC suggested in this thesis, which is repeated in (67) below, the Theme object moves to the Spec of AGRo across the Goal object in the Spec of V^l.

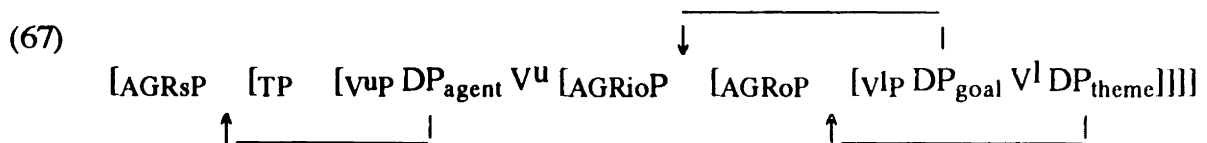

If this structure is correct, the DOC should be ungrammatical without the domain extension convention and equidistance. Since we are almost in a position to eliminate the domain extension convention, it would be instructive to consider an alternative analysis of the DOC that does not rely on the domain extension convention.

An obvious and the only alternative analysis I can think of is to "split" the lower verb into two separate verbs, say V^m and V^l , as shown in (68) (TP is not indicated for brevity's sake).²⁰

(68) [AGRsP [VuP DP_{agent} V^u [AGRioP [VmP DP_{goal} V^m [AGRoP [vIP V^l DP_{theme}]]]]]]

↑ _____ | ↑ _____ | ↑ _____ |

In this structure, the issue of Relativized Minimality does not arise, because the three argument chains do not intersect with each other. Thus, we need not assume the domain extension convention. There are some suggestive data in favor of (68) over (67). First, consider (69).

- (69) a. I gave the kids all some candy (to keep them quiet).
 b. Dad bought the twins both bicycles (for Christmas).

(Maling 1976)

Assuming Sportiche's (1988) theory of floating quantifiers, these examples suggest that there is a specifier position between the surface positions of the Goal object and the Theme object, and this position is occupied by a constituent consisting of the floating quantifier and a trace of the Goal object, as shown in (70).

(70) ... [AGRioP the kids_i [XP all t_i X [AGRoP some candy ...

In (68), this specifier position can be the Spec of V^m , but there is no such position in (67).

A second piece of supporting evidence for (68) comes from Japanese examples in (71).

- (71) a. Mary-ga [vP John to Bill-ni [v' otagai-o t_v]] syookaisita.
Mary-Nom John and Bill-Dat e.o. -Acc introduced
 Lit. 'Mary introduced to John and Bill each other.'

²⁰ The structure (68) have been suggested to me by Yoshiki Ogawa, David Pesetsky, and Jonathan Bobaljik for various different reasons we cannot discuss here. I would like to thank them. Bobaljik (1995: Chapter IV) contains an explicit argument for the structure (68).

- b. * Mary-ga otagai-o_i John to Bill-ni t_j syookaisita.
Mary-Nom e.o. -Acc John and Bill-Dat introduced

The example (71)b is a violation of Condition C with *otagai* c-commanding its antecedent "John and Bill". It also violates the Chain Condition as the closest binder of the trace of *otagai*, *t_j*, is "John and Bill" rather than *otagai*. Now, in LF the Accusative object in (71)a raises to the Spec of AGR_oP across the Goal object or its trace depending on whether the Goal object raises to the Spec of AGR_iO. Thus, under the analysis of the DOC given in (67), (71)a has as its partial LF representation either (72)a or (72)b.

- (72) a. ... [AGRoP otagai-o_i [VP John to Bill-ni [V' t_j ...
 b. ... [AGRioP John to Bill-ni_j [AGRoP otagai-o_i [VP t_j [V' t_i ...

Both structures violate the Chain Condition. (72)a violates Condition C as well. Thus, if these conditions apply at LF, the structures in (72) cannot be the correct LF representation of the grammatical (71)a. The analysis of the DOC given in (68), on the other hand, assigns a grammatical LF representation to (71)a. This is shown below.

- (73) ... [AGRioP [v_{MP} John to Bill-ni [AGRoP otagai-o_i [v_{IP} t_j ...
 (↑ _____)

In this structure, neither the Chain Condition nor Condition C is violated regardless of whether the Goal object raises to the Spec of AGR_iO. Thus, the grammaticality of (71)a is another piece of empirical evidence in favor of (68).²¹ Incidentally, under this analysis, the accusative object in (71)b is adjoined to AGR_iO as a result of scrambling.

We have discussed three reasons to adopt the analysis of the DOC in (68) rather than the analysis in (67): i) elimination of the domain extension convention, ii) English DOC sentences with a floating quantifier such as (69), and iii) Japanese DOC examples with an accusative reciprocal such as (71). A potential problem with this new analysis of the DOC is the (somewhat) degraded status of the examples like (74).

²¹ An alternative analysis of (71)a that is compatible with (67) as well as (68) is to assume that in LF only some features of the accusative object, rather than the entire object, move along the lines of Chomsky (Class lectures, Fall 1994).

- (74) a. ?* Mary gave John secretly the book (on Friday).
 b. ?* Amber told Ben quietly the story (in the living room)

In Chapter 2, assuming the structure (67), we ruled out these examples by saying that the adverbs are adjoined to AGR_{IO'} or AGR_{OP}, which does not have ability to license adverbs (because AGR and its projections are semantically inert). However, if (68) is the correct structure, we lose this account, because there is a VP node between the surface positions of the two objects, to which VP-adverbs should be able to adjoin. David Pesetsky (personal communication) told me that this might be a welcome result because the deviancy of the examples like (74) is less serious than the deviancy of other examples that we exclude by the same reason (i.e. adverbs adjoining to a projection of AGR). If so, there must be some other reason why the examples in (74) are not perfect. Although at this moment it is not clear to me exactly what it is, a possibility is that V^m in (68) is not really a verb, rather it is an applicative morpheme of some sort familiar from Bantu literatures, and the applicative morpheme is to some extent semantically incompatible with VP-adverbs. If this turns out to be the case, the particle in (75) might be a spell-out of this applicative morpheme.²²

- (75) The secretary sent the stockholders out a schedule.

To summarize this section, the domain extension convention can be eliminated from the grammar to the extent that an analysis of the DOC along the lines of (68) can be supported, which seems to have some initial plausibility.

²² If the last remark is indeed correct, then the applicative morpheme must present not only in the DOC but also in other types of verb-particle constructions such as the following.

- (i) a. The secretary sent out a schedule to the stockholders.
 b. The secretary sent a schedule out to the stockholders.
 c. Amber looked up the reference.
 d. Amber looked the reference up.
 e. ? Joni made out Becky to be a liar.
 f. Joni made Becky out to be a liar.

5. Conclusion

In this chapter I have argued that a traditional VP in fact consists of two VPs separated by one or more functional projections such as AGRoP. The so-called external argument is generated in the Spec of the upper V, and the internal arguments are generated within the lower VP.

Appendix to Chapter Five: Related Proposals

Since I first proposed the Split VP Hypothesis in a paper I wrote in 1992, a number of works came to my attention in which a suggestion similar to the Split VP Hypothesis is made.²³ In this section, I briefly discuss those papers. Since many of them are yet to be published, it would be premature to be very critical. Rather my primary purpose here is to acknowledge the existence of a family of proposals that share some basic insight with mine.

Nakayama & Koizumi (1991) and Bowers (1993), among others, argue that the base-position of the external argument is outside the VP that dominates the main verb and the object (when it exists), as shown in (76).

(76) [XP NP_{ext} [X VP]]

They suggest that the external argument is related to the VP by predication, and it moves to the Spec of an Infl-type functional category for Case-theoretic reasons (at least in some languages). The category of X is subject to language variation according to Nakayama & Koizumi (1991), whereas in Bowers (1993) XP is called Predication Phrase (PrP). Hung (1988) and Speas (1990) propose a similar structure, but for them X in (76) is an abstract "causative" verb of which the NP_{ext} is an argument.

Kratzer (1994) suggests that X in (76) is a functional category named Voice. NP_{ext} is an argument of Voice, and is related to the VP through secondary predication. Voice is of the semantic type $\langle e, \langle s, t \rangle \rangle$, and VP is of the type $\langle s, t \rangle$. By her Event Identification, Voice' will be of the type $\langle e, \langle s, t \rangle \rangle$:

²³ As far as I can remember, the first time I presented the Split VP Hypothesis outside MIT was at the LSA annual meeting held in Los Angeles, January 1993 (Koizumi 1993a). A revised version is distributed by the MIT Working Papers in Linguistics (Koizumi 1993c).

(77) Example of Event Identification

$$\begin{array}{ccc} \mathbf{f} & \mathbf{g} & \rightarrow \\ \langle e, \langle s, \Delta \rangle \rangle & \langle s, \Delta \rangle & \mathbf{h} \\ \lambda x_e \lambda e_s \text{Agent}(x)(e) & \lambda e_s \text{wash}(\text{the clothes})(e) & \langle e, \langle s, \Delta \rangle \rangle \\ & & \lambda x_e \lambda e_s [\text{Agent}(x)(e) \& \text{wash}(\text{the clothes})(e)] \end{array}$$

(Kratzer 1994: 113)

Kratzer's proposal about semantic interpretation is neutral with respect to the categorial status of X. It works equally well if X is a verb as in our Split VP structure, rather than Voice.

Kratzer presents two arguments against the view that X is a verb. One has to do with the mode of Case assignment. Since it does not hold of the Split VP Hypothesis, we will not discuss it here. The second objection comes from her observation that the external arguments in sentences like (78) are obligatory.

- (78) a. **Elsa** wrote those poems with this pen.
b. **Franz** read the poems on this sofa.
c. **George** sold the sofa to my aunt.

"If external arguments are introduced by higher verbs", she asks, "what is it that makes their introduction obligatory in these sentences?" "If [X] is an inflection [such as Voice]", on the other hand, it is expected that "it must be present in finite constructions." Thus, for Kratzer, external arguments must occur in finite clauses because they are selected by Voice, which is an obligatory element of finite constructions.

I have different factual evaluations: External arguments are often optional in tensed clauses. Consider:

- (79) a. **Becky** opened the door.
b. The door opened.

- (80) a. **They** sank the ship.
b. The ship sank.

- (81) a. **Kiyomi-ga** hon-o 3-satu ur-ta.
Kiyomi-NOM book-ACC 3-CL sell-PAST
'Kiyomi sold three books.'
b. Hon-ga 3-satu ure-ta.
book-NOM 3-CL sell-PAST

Lit. 'Three books sold.'

(Three books were sold) (cf. the verb list in (11))

This is exactly what is expected if X is an optional element such as a verb. On the other hand, if X is an inflectional element obligatory in finite clauses, it comes as a surprise if we get alternations like those in (79) through (81). It is true that the external arguments in (78)a, b are obligatory, but this does not mean that external arguments are *always* obligatory in finite constructions.²⁴ I would say that the obligatoriness of the external arguments in these examples has to do with the fact that reading and writing events necessarily involve agent-participants (reader/writer). There does not seem to be a sub-event of a reading/writing event, that excludes the reader/writer. If there are such sub-events at all, they must be highly unnatural from the view point of human cognition, to say the least. Thus, it is not surprising that such unnatural sub-events are not lexicalized in most (if not all) languages. Clearly more has to be said about what is considered to be a "natural" lexical item (and naturalness of course is not the only factor that governs lexicalization). To do so, however, is far beyond the scope of the present work. Suffice it to say that, since external arguments are optional in many cases as we have seen, there is no reason to believe that the head that selects them is an obligatory Infl element, rather than a verb.

Hale & Keyser (1991; 1993) have developed a theory of lexical syntax (l-syntax), according to which the structure of (82) is essentially as in (83).

(82) John opened the door.

²⁴ I assume, with Keyser & Roeper (1984) and others, that middle constructions like (i) involve implicit external arguments.

- (i) a. This book reads well.
b. Sofas sell easily.

(83)

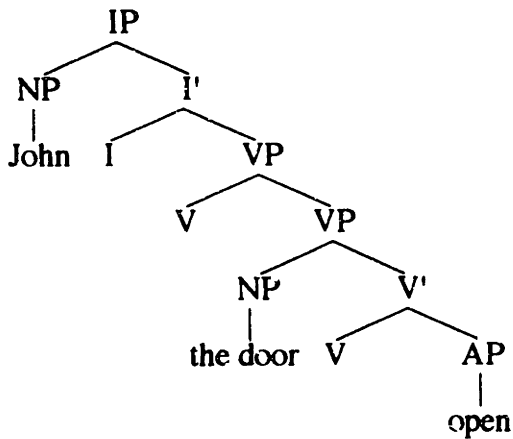

This structure is similar to our Split VP structure in (9), repeated here as (84), at least in two relevant respects: i) the external argument is outside the VP for the object (i.e. lower VP), and ii) in addition: to the VP for the object (the lower VP), there is another VP that is responsible for the occurrence of the external argument (the higher VP).

(84)

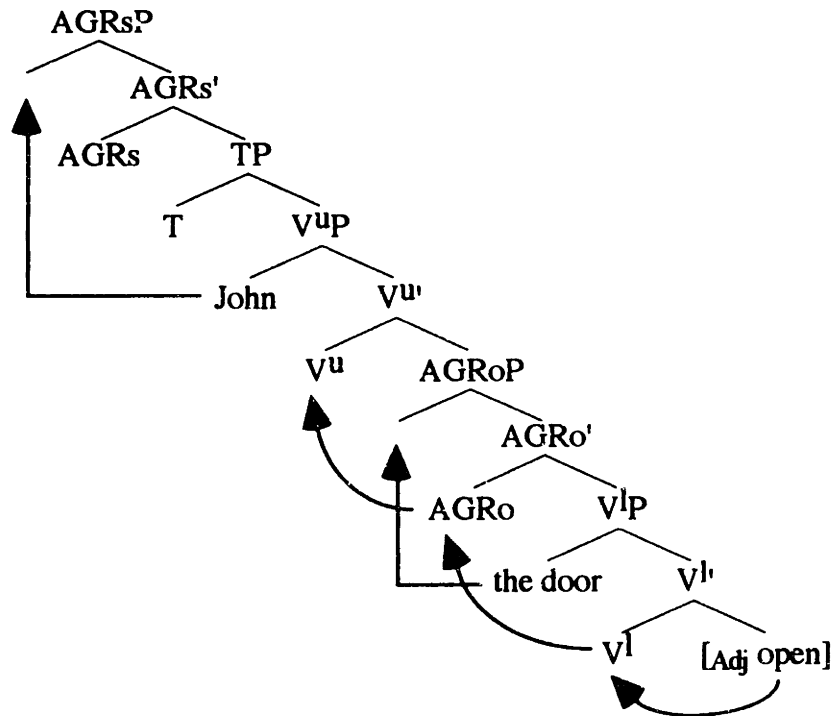

There are also at least two crucial differences between Hale & Keyser analysis and the Split VP Hypothesis. First, in the former the object is Case-licensed, without movement, in its base-position, whereas in our analysis it moves to the Spec of AGRo at

some point of derivation. If our arguments in Chapter 2 through Chapter 4 are correct, there is good reason to believe that the object moves to some higher position, identified as the Spec of AGRo in the present work. Hale & Keyser analysis as it is, fails to capture this aspect of grammar. The other, and in a sense more important, difference between the two proposals is that the external argument is base-generated in its surface position in their system, while it originates in a position lower than its surface position in our analysis. The arguments for the Internal Subject Hypothesis we reviewed in § 3 favor the Split VP Hypothesis.

Johnson (1991; 1992) and Sportiche (1990) argue that the object NP, generated as a sister of a verb, moves to the Spec of the verb, which is a structural Case position and is lower than the base-position of the subject.

(85) $NP_{ext} [VP [V' V NP_{int}]]$
 $\uparrow \text{-----} \downarrow$

See Chapter 2 and 3 for some problems with this analysis. Sportiche (1990) mentions, in the appendix to Chapter 5, a possibility that, if there is AGRo, and the landing site of the object NP is the Spec of AGRo, the base-position of the subject is still higher than that position. This I think is essentially the same proposal as our Split VP Hypothesis. See also Fujita (1993; 1994a; 1994b) for a similar proposal.

Based on word order facts in Western Austronesian languages and a consideration of aspectual interpretation of events, Travis (1992a; 1992b) suggests the following structure of the VP.

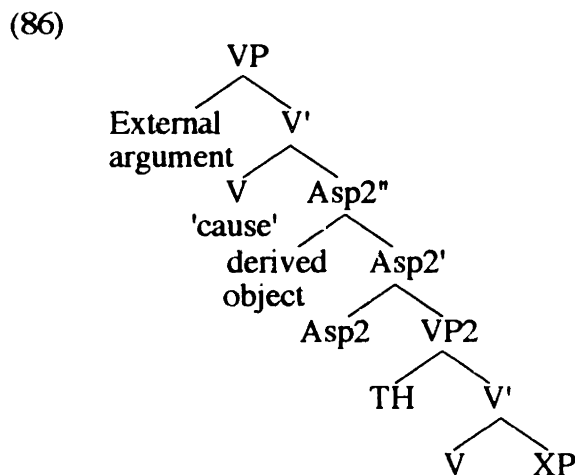

Travis assumes that there are two aspect head positions in a clause. Asp1, which is not shown in the structure, indicates whether or not the action has started, and Asp2 indicates whether or not the action is completed. The Spec of Asp2 is "a derived object position". In Kalagan (a Philippine language), it is the designated position to which the "topic" (the nominative case marked element) moves. A variety of constituents can be the topic, e.g. the subject, the object, the instrumental, the benefactive, the locative, etc.

The similarity between the structure in (86) and the Split VP structure in (84) is obvious, although it is not clear if Travis' Asp2 can be identified with our AGRo. A possibility is that they are two different entities, co-existing in a clause structure along the lines of (87).

(87)

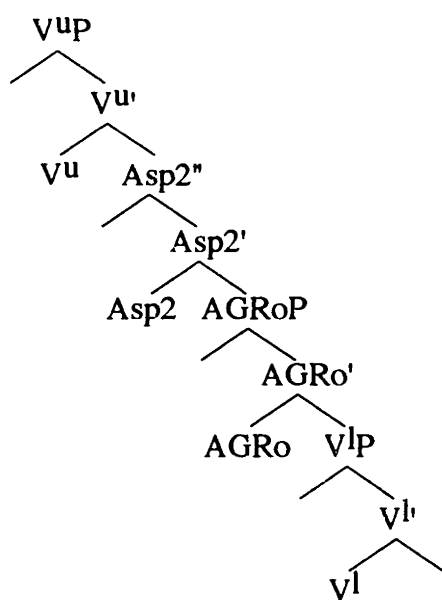

This is reminiscent of the structure proposed for the Icelandic double object construction in Collins and Thráinsson (1993), which is shown below.

(88)

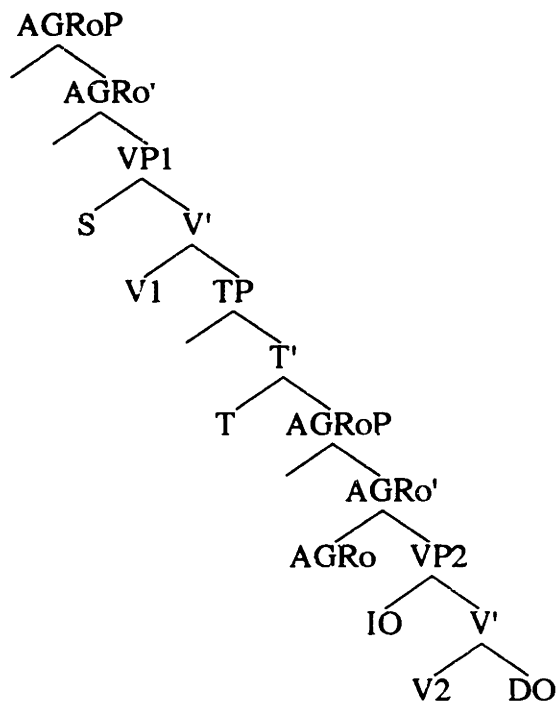

See also Ura (1994b) for discussion of the typological variety of the double object constructions.

CHAPTER SIX

LAYERED SPECIFIERS

The standard X'-schema in (1) expresses the three points stated in (2), among others (cf. Chomsky 1986b).

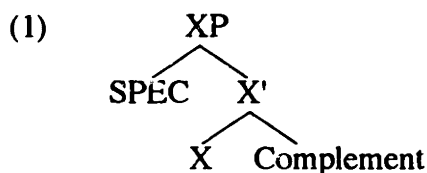

- (2) Asymmetry: A node is projected from only one of its daughters.
Binarity: A node may have (at most) two daughters.
Maximality: A head may project (at most) two non-minimal projections.

From Asymmetry and Binarity, it follows that a head may take at most one sister (i.e. a complement) (A). To derive that a head may host at most one non-sister (i.e. a specifier) (B), Maximality needs to be stipulated in addition.

Recently, Chomsky (1994) proposed to eliminate X'-schemata of any kind, deriving instead its empirical effects from what he calls a theory of BARE PHRASE STRUCTURE. The core of the bare phrase structure theory is MERGER (a generalized transformation), which takes two syntactic units and puts them together, asymmetrically projecting one of the two inputs. As before, Asymmetry and Binarity are crucially assumed, guaranteeing (A), though Maximality is not incorporated into the system. In the minimalist framework being developed by Chomsky and others, Merger is held to follow from virtual conceptual necessity, because in this framework linguistic expressions with more than one terminal node cannot be created without some kind of generalized transformation, binary Merger being the simplest possible one.

Unlike the X'-schema (1), Merger does not guarantee (B). The theory of bare phrase structure as it stands, therefore, does not preclude a structure with multiple specifier positions such as (3).

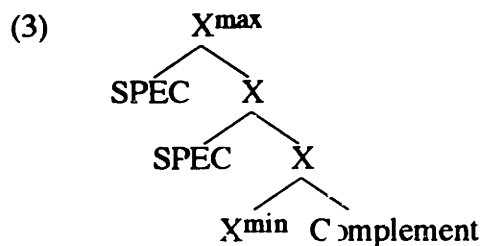

While this might appear to be a defect of the bare phrase structure theory, I will argue to the contrary that multiple specifiers are indeed required in natural language. Specifically, in this chapter I will present evidence for functional projections with two or more specifier positions (or layered specifiers). Hence, allowing layered specifiers is a virtue of the bare phrase structure theory, rather than a defect thereof. This is a welcome result, because Maximality, which has never been conceptually necessary, can be now dispensed with on empirical grounds.

In § 1, we will discuss categories with two features for two different specifier positions. In § 2, we will consider cases with more than two specifier positions licensed by a single feature. Finally in § 3, we turn to a functional head with two different features each of which may enter into checking relation with more than one element. In due course, it will be demonstrated that EQUIDISTANCE of Chomsky (1993b) applies not only to A-movement but also to A-bar movement (contra Watanabe 1993; see also Branigan 1992).

1. Double-Layered Specifiers

In this section we will discuss two cases motivating the postulation of two specifier positions for a single head.

1.1. Topicalization in English

Since Higgins (1973), there has been a long debate as to whether Topicalization in English is an adjunction or substitution operation, and this issue has not been settled yet (cf. Authier 1992; Baltin 1982; Bowers 1976; Chomsky 1977; Culicover 1991; Iwakura 1978; Kuwabara 1992; Lasnik and Saito 1992; Müller and Sternefeld 1993; Noji 1993; Rochemont 1989; Toyoshima 1991; Watanabe 1993, among others). Assuming that there is only one CP-type projection above IP, Lasnik & Saito (1992), for example, argue that, since the embedded topic exemplified in (4) occurs between the complementizer and the subject, it must be adjoined to IP, as shown in (5).

(4) Robin says that, **the birdseed**, he is going to put in the shed.

- (5) IP-adjunction Analysis:
 ... [CP that [IP **Topic** [IP Subject ...
 (Lasnik and Saito 1992; Rochemont 1989, among others)

As has occasionally been observed in the literature. Subject-AUX inversion may occur in certain types of embedded clauses. Consider (6) (cf. Hooper and Thompson 1973; Culicover 1991; Authier 1992).

- (6) a. Becky said that at no time would she agree to visit Marty.
 b. John swore that under no circumstances would he accept their offer.

If we assume, following Chomsky (1986b), that Subject-AUX inversion is the result of AUX movement from Infl to a higher head position (e.g. C), then (6) suggests that between IP and CP there is another set of complementizer-type projections whose head hosts the auxiliary. Since Subject-AUX inversion in (6) appears to be induced by the preposed "affective" element, it seems natural to suppose that the auxiliaries and the preposed constituents enter into Spec-head agreement. Then the pertinent portion of (6) has a structure like (7).

- (7) ... [CP₁ that [CP₂ PNC [C' AUX [IP ... (PNC: Preposed Negative Constituent)

Given the second CP-type projection, Lasnik & Saito's argument loses its force, for the embedded topic between the complementizer and the subject may well be in the Spec of the second C. In fact, citing Hooper & Thompson's (1973) observation that all the environments in which Topicalization is possible are also environments that allow fronting of "affective" elements, Authier (1992) argues that topic phrases, like preposed affective elements, occupy the Spec of the second CP. Under his analysis, embedded Topicalization creates a structure like (8).

- (8) Spec of the Second CP-type projection Analysis:
 ... [CP₁ that [CP₂ Topic [C' C₀ [IP Subject ...
 (Authier 1992; Noji 1993; Watanabe 1993, etc.)

There are several problems with this analysis. First, as pointed out by Culicover (1991), Topicalization creates a syntactic island whereas preposing of an affective element, such as Negative Preposing, does not. This is shown below.

- (9) a. * On which table did Lee say that these books she will put.
b. On which table did Lee say that only these books would she put.
- (10) a. * Which books did Becky say that to Aaron she will give?
b. Which books did Becky say that only to Aaron will she give?
- (11) a. * This is the book that John said that Mary_i he would inform t_j that I had read.
b. This is the book that John said that only Mary_i would he inform t_j that I had read.

If the topic phrase and the preposed negative constituent occupy the same position as argued by Authier, the (a) sentences and the (b) sentences in (9) through (11) should be equally good or equally bad, a wrong prediction.

Another piece of evidence against Authier's analysis is given in (12), in which a topic phrase and a preposed negative constituent co-occur (cf. Kuwabara 1992).

- (12) a. Becky said that these books, only with great difficulty can she carry.
b. He said that beans, never in his life had he been able to stand.

This is problematic for Authier's analysis because his analysis crucially assumes that the topic and the preposed negative constituent occupy the same position, which incorrectly predicts that they cannot co-occur. Incidentally, when they occur in the same clause, they constitute a syntactic island, as exemplified in (13)a. This shows that it is not Subject-AUX inversion that is responsible for the absence of island effects in the negative preposing sentences shown above. Furthermore, the topic must precede the preposed negative constituent. Other orders yield ungrammaticality, as demonstrated in (13)b, c.

- (13) a. * On which table did Becky say that these books, only with great difficulty can she put?
b. * Becky said that only with great difficulty can these books she carry.
c. * Becky said that only with great difficulty these books can she carry.

Thus, it is clear that a topic phrase is not placed in the same position as a preposed affective element (i.e. the Spec of the lower C). Then where is the topic located? I suggest that the second CP in English has two specifier positions. To avoid terminological confusion that might arise from having two CPs, I refer to the second, i.e. lower, complementizer type projection as Polarity Phrase, or PolP, following Culicover's (1991) terminology. Using this new category name, I suggest that PolP in English may have (at most) two specifier positions, as shown in (14). This amounts to saying that the head of PolP in English may have two sets of NP-features, one for the canonical Spec, and one for the non-canonical (or adjoined) Spec. The two positions are called specifier positions (of Pol) because the elements in these positions enter into the checking relation with the head (Pol).¹

(14) Layered Specifiers Analysis

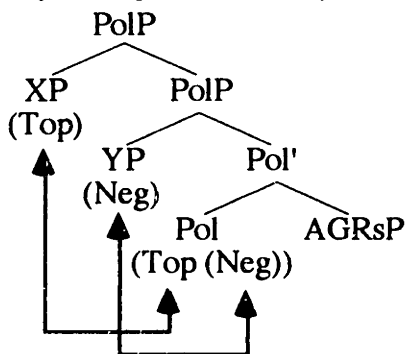

As θ -roles of a verb are hierarchically ordered (e.g. Agent > theme), so are NP-features of Pol (e.g. Top > Neg).² The preposed negative constituent is licensed in the canonical specifier position, whereas the topic phrase is licensed in the adjoined specifier position. Under this analysis, (12)a has the structure in (15).

(15) ... [CP that [PolP these books [PolP only with great difficulty [Pol' can [AGRsP ...

¹ The canonical Spec of a head X is a specifier position dominated by X^{max} , and the adjoined Spec is a specifier position contained in, but not dominated by, X^{max} .

² I assume that both Top and Neg are features of Pol. A plausible alternative is that these features originate from other heads (e.g. the Neg feature from the head of NegP (or Σ P in the sense of Laka 1990), the Top feature from Tense (cf. Fukui 1993)), and that PolP merely provides positions for feature checking.

The head of PolP in (15) has a Neg feature to be checked against the Neg feature of the negative constituent in the canonical Spec, as well as a Topic feature to be checked against the Topic feature of the topic phrase in the adjoined Spec. Since the adjoined Spec and the canonical Spec are both in the checking domain of the head of PolP, the constituents in these positions enter into the checking relation with the head.

This analysis captures the intuition behind Authier's analysis given in (7), because in the present analysis, as in Authier's analysis, topic phrases and preposed negative constituents are licensed by the same category, i.e. Pol, and topic phrases are located in a specifier position. This accounts for the distributional similarity between Topicalization and Negative Preposing. At the same time, the present analysis is similar to the IP adjunction analysis of Lasnik & Saito (1992) in that the position for the topic phrase is not the canonical specifier position. Not many categories have two specifiers. In this sense, the upper Spec of Pol is a somewhat marked position. This may well be the reason why some speakers do not like Topicalization.

Let us now return to (13)a, repeated here as (16)a. Assuming that only specifier positions can serve as landing sites (intermediate or ultimate) for movement, the example has the partial schematic structure in (16)b.

(16) a. * On which table did Becky say that these books, only with great difficulty can she put?

b.

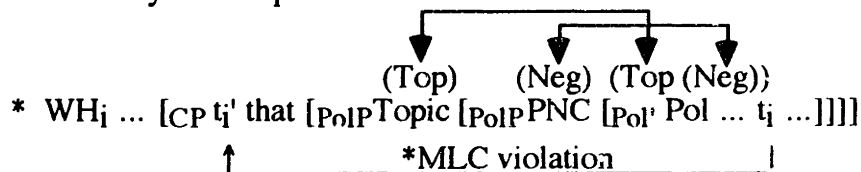

In this structure, the first movement of the wh-phrase crosses the two A-bar specifiers of the embedded Pol. Since the canonical Spec of Pol is not equidistant with the Spec of the embedded C, the wh-movement violates the Minimal Link Condition (MLC) of Chomsky (1993b; 1994) (cf. also Chomsky and Lasnik 1993). The sentence is therefore ungrammatical.

Next consider (10), repeated here as (17).

(17) a. * Which books did Becky say that to Aaron she will give?

b. Which books did Becky say that only to Aaron will she give?

Under our analysis, (17)b has the partial derivation in (18).

(18) Str. of (17)b

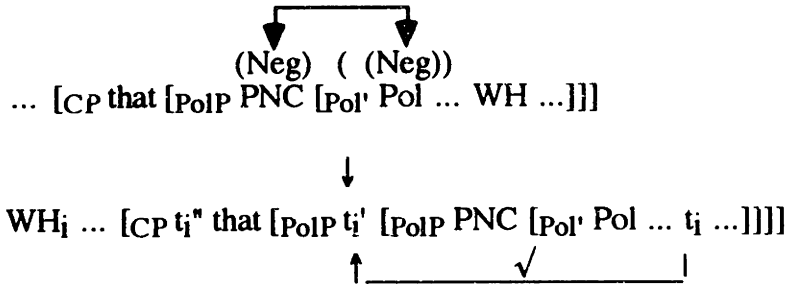

In (18), the *wh*-phrase moves to the sentence initial position through the adjoined Spec of the embedded Pol. The first step of this movement appears to violate the MLC because it crosses a potential A-bar landing site, i.e. the canonical Spec of Pol.³ However, the MLC is not violated here, for the adjoined Spec and the canonical Spec of Pol are equidistant from any other positions as they are both in the checking domain (hence in the minimal domain) of Pol.

As for (17)a, there are two conceivable derivations. Their pertinent portions are shown in (19) and (20).

(19) Su. of (17)a I

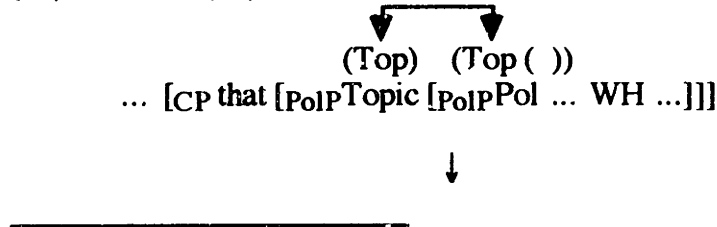

³ Negative Preposing is A-bar movement. It can cross tensed clause boundaries, and it induces Weak Crossover effects.

- (i) a. In none of these houses do I believe that a student could live t safely.
- b. * No book_j would I expect its_j author to praise t publicly.

Negative Preposing is also possible across a preposed negative constituent.

- (ii) No race would I expect that only with great difficulty could Lewis win.

Here the sentence initial PNP crosses the PNP in the embedded clause basically in the same manner as the *wh*-phrase crosses the embedded PNP in (18).

*WH_i ... [CP t_i' that [P_oIP Topic [P_oIP Pol ... t_i ...]]]
 ↑ _____ *MLC violation _____ ↓

(20) Str. of (17)a II

... [CP that [P_oIP Topic [P_oIP Pol ... WH ...]]]
 ↓
 *WH_i ... [CP t_i' that [P_oIP Topic [P_oIP t_i' [P_oI' Pol ... t_i ...]]]
 ↑ _____ *MLC violation _____ ↑ _____ ↓

In (19), the wh-phrase moves from its original position to the Spec of the embedded C in one fell swoop. In (20), it stops by at the lower Spec of Pol on its way. In either case, it crosses the topic phrase in the Spec of Pol. Since (17)a is clearly unacceptable, we would like both of the derivations to be illegitimate. Specifically, we would like the movement across the topic phrase to be in violation of the MLC. Under Chomsky's (1993b) definition of the *minimal* domain given in (21) below, this is not the case, because both the Spec of C and the adjoined Spec of Pol are in the minimal domain of the same head, C. I would like to suggest modifying its definition as shown in (22).

(21) Chomsky's original definition of MIN(S)

MIN (S), S a set of categories, is the smallest subset K of S such that for any $\gamma \in S$, some $\beta \in K$ reflexively **dominates** γ .

(22) Our definition of MIN(S)

MIN (S), S a set of categories, is the smallest subset K of S such that for any $\gamma \in S$, some $\beta \in K$ reflexively **contains** γ .

Given (22), the Spec of the embedded C and the adjoined Spec of Pol are not in the same minimal domain, hence they are not equidistant from other positions. Thus, (19) and (20) both violate the MLC. (17)a is therefore ungrammatical.⁴

⁴ That fact that adjuncts adjoined to a projection of Pol do not create syntactic islands as shown in (i) below indicates that either adjuncts may be introduced into a phrase marker non-cyclically or they are projected on a different plane of a three dimensional phrase structure so that they are invisible for the purpose of locality conditions.

(i) a. I asked what [P_oIP in your opinion [P_oIP Robin gave to Lee]](Culicover 1991)
 (→ *continue*)

To summarize, we have observed that the postulation of layered specifiers makes possible a simple and principled account of the distributions of topic phrases and preposed negative constituents, which are problematic for previous analyses such as Authier's (1992).

A conceivable alternative analysis that comes to mind immediately is that our adjoined Spec of Pol is the Spec of another head that occurs between C and Pol. Suppose that there are three complementizer-type categories above AGRsP, and the topic occupies the Spec of the second C. Then clauses like (12) with both the topic and the PNC will have essentially the following structure (cf. Nakamura 1994).

(23) ... [CP₁ that [CP₂ Topic C₂ [CP₃ PNC AUX [AGR_{sP} Subject ...

This structure readily accounts for the fact that the topic always precedes the PNC in the same clause (cf. (13)b,c). A weakness of this hypothesis is that there is no evidence for the presence of the head C₂. We only know the presence of the position occupied by the topic. Another problem with this analysis is that it assigns a structure like (25) to examples with movement across a PNC such as those in (24).

- (24) a. Which books did Becky say that only to Aaron will she give?
 b. No race would I expect that only with great difficulty could Lewis win.

(25) WH_i/PNC_i ... [CP₁ that [CP₂ t_i' C₂ [CP₃ PNC AUX [AGR_{sP} Subject ... t_i ...
 ↑ _____ *MLC violation _____ ↓

As we have seen earlier, and as the examples in (24) show, a PNC does not create a syntactic island. However, the structure in (25) clearly violates the MLC. Thus, if it were the correct structure of (24), the examples should be ungrammatical.

-
- b. Becky forgot which dishes Marty had said that under normal circumstances you would put on the table.
 c. Bill certainly I really hate. (Greenberg 1984)

We have so far restricted ourselves to embedded Topicalization. Before closing this subsection, let us briefly discuss matrix Topicalization for completeness. According to Culicover (1991), matrix clauses lack CP,⁵ and a fronted wh-phrase of matrix wh-questions occupies the [canonical] Spec of Pol, as shown in (26).

(26) Matrix clauses lack CP: [PolP what did [AGRsP you buy t]]

Thus, in matrix clauses, a topic precedes a fronted wh-phrase as well as a PNC, as exemplified in (27) and (28). The (a) sentences have the structure in (29).

(27) a. And a book like this, to whom would you give? (Delahunty 1983)

b. * To whom, a book like this would you give?

(28) a. To John, nothing would we give.

b. * Nothing, to John would we give.

(29) Matrix Topicalization + Wh-movement/Negative Preposing

[PolP Topic [PolP WH/PNC [Pol' [Pol AUX] [AGRsP ...

The examples in (27)b and (28)b are ungrammatical because the topic is in the canonical Spec of Pol, which cannot host the topic phrase as mentioned above (see (14)). Since fronted wh-phrases and PNCs are both licensed in the canonical Spec of Pol, they cannot co-occur in matrix clauses.

(30) a. * Only with great difficulty on which table would she put the big rock?

b. ?* On which table only with great difficulty would she put the big rock?

(cf. √ I wonder [CP on which table [PolP only with great difficulty would [AGRsP she put the big rock]])

In this subsection, I have presented evidence for "layered specifiers". Topicalization in English is a movement to the adjoined Spec of Pol, whereas Negative Preposing is movement to the canonical Spec of Pol. Given this, the Topic Island phenomenon is readily explained by the Minimal Link Condition. Absence of island effects

⁵ This is natural considering that C is a *complement-izer*, and the matrix clause is not a complement by definition.

in the case of negative preposing suggests that the notion of equidistance in the sense of Chomsky (1993b) is operative in A-bar movement as well as in A-movement. In the next subsection, I will present further evidence for layered specifiers.

1.2. Embedded V2

Germanic languages typically have verb-second (V2) word order in matrix clauses, as illustrated by the following German examples.

- (31) a. Peter kauft das Buch
Peter buys the book
 b. das Buch kauft Peter
the book buys Peter
 c. * Peter das Buch kauft
Peter the book buys

The V2 word order is not allowed in embedded clauses with overt complementizers in languages like German and Dutch:

- (32) a. * Ich glaube, daß das Buch kauft Peter
I think that the book buys Peter
 b. Ich glaube, daß Peter das Buch kauft
I think that Peter the book buys

However, there are languages in the Germanic family that do allow such constructions. Consider the following examples with a fronted phrase.

- (33) a. Ir zolt visn zayn, mayne libe kinderlekh, az
You (pl) should know be my dear children that
 vayn ken men makhn fun troybn oykh.
wine can one make from grapes also (Yiddish: Diesing 1990)
 'You should know my dear children that one can make wine from grapes also.'
 b. Jón segir að þessum hring hafi Ólafur lofað Marfu.
Jon says that this ring has Olaf promised Mary
 (Icelandic: Thráinsson 1985)

- c. Vi ved at denne bog har Bo ikke læst.
We know that this book has Bo not read

(Danish: Vikner 1991: 78)

- d. Jag vet att Eva kan man lita på.
I know that Eva can you rely on

(Swedish: Holmberg 1986: 110)

The null hypothesis about the structures of these embedded V2 clauses (with overt complementizers) is that they all have basically the same structure. As we have just observed, PolP is the locus of the Negative Preposing in English, an instance of embedded V2. It seems natural to extend this analysis to embedded V2 in other Germanic languages. If so, the sentences in (33) schematically have the structure in (34) (cf. deHaan and Weerman, 1985; Holmberg 1986; Vikner 1991).

(34) Embedded V2 (A Uniform Analysis):

... [CP C [PolP XP [Pol' [Pol V] [AGRsP ...]]]]

Among languages in which the verb-second word order is optionally possible in embedded clauses introduced by overt complementizers, Yiddish and Icelandic allow syntactic extraction out of such embedded clauses, while Danish, Swedish, Frisian etc. do not. Some examples of wh-movement from within embedded clauses with V2 word order are shown in (35) and (36).

- (35) a. Vos hot er nit gevolt az in shul zoln di kinder leyenen?
what has he not wanted that in school shall the children read

(Yiddish: Santorini 1989: 59)

- b. Hvaða blað sagði hún að á morgnana gæti hún bara rennt
which paper said she that in the morning could she only skim
 yfir en á kvöldin reyndi hún að lesa vandlega?
over but in the evening tried she to read carefully

(Icelandic: Iatridou and Kroch 1993)

- (36) a. * Hvilken film sagde hun at i skolen havde børnene
Which film said she that in school-the had children-the
 allerede set?
already seen

(Danish: Vikner 1991: 123)

- b. * Viken fest sa hon att roliga hattar skuella vi inte köpa till?
which party said she that funny hats should we not buy for
 (Swedish: Holmberg 1986: 111)

Note that all these languages allow syntactic extraction out of embedded clauses without Topicalization.

- (37) a. Vos hot er nit gevolt az di kinder zoln leyenen?
what has he not wanted that the children should read
 (Yiddish: Santorini 1989: 59)
- b. Hvaða mynd sagði hún að börnin hefðu þegar séð
which film said she that children-the had already seen
 (Icelandic: Vikner 1991: 123)
- (38) a. Hvilken film sagde hun at børnene allerede havde set?
Which film said she that children-the already had seen
 (Danish: Vikner 1991: 123)
- b. Viken fest sa hon att vi inte skuella köpa roliga hattar till?
which party said she that we not should buy funny hats for
 (Swedish: Holmberg 1986: 111)

These examples suggest that V2 creates a syntactic island in Danish and Swedish, but not in Yiddish and Icelandic (with respect to argument extraction).⁶ Why is this the case?

I suggest that Pol in Yiddish and Icelandic, like Pol in English, allows two specifier positions, whereas Po¹ in Danish and Swedish has only one specifier position. Thus, the examples in (35) and (36) have the structures in (39) and (40), respectively.

(39) Yiddish/Icelandic/English-type languages (Pol has two Spec positions)
 $\sqrt{\text{WH}_i \dots [\text{CP } t_i^* \text{ C } [\text{PolP } t_i^* [\text{PolP } \text{XP } [\text{Pol}' \text{ AUX } [\text{AGRsP } \dots t_i \dots]]]]]$
 $\uparrow \underline{\hspace{1cm}} \parallel \underline{\hspace{1cm}} \parallel \underline{\hspace{1cm}} \parallel$

(40) Danish/Swedish/Frisian-type languages (Pol has only one Spec position)
 $*\text{WH}_i \dots [\text{CP } t_i^* \text{ C } [\text{PolP } \text{XP } [\text{Pol}' \text{ AUX } [\text{AGRsP } \dots t_i \dots]]]]$
 $\uparrow \underline{\hspace{1cm}} \parallel \underline{\hspace{1cm}} \parallel \underline{\hspace{1cm}} \parallel \underline{\hspace{1cm}} \parallel$

⁶ For adjunct extraction, see footnote 9.

In (40), the first step of the *wh*-movement violates the MLC because it crosses the Spec of Pol, a potential A-bar landing site. In (39), on the other hand, MLC violations do not arise, for the *wh*-phrase uses, as an escape hatch, the adjoined Spec of the embedded Pol. Remember that the adjoined Spec and the canonical Spec of the same head are equidistant from any other position because they are both in the checking domain of Pol. The assumption that Pol in languages like Icelandic and English allows two specifier positions is justified by the sentences in (41), in which we can observe two NPs between the complementizer and the head of PolP.

- (41) a. Becky said [_{CP} that [_{PolP} these books [_{PolP} only with great difficulty
[_{Pol'} can [_{AGR_{SP}} she carry]]]]] (English: = (12)a)
- b. Jón segir [_{CP} að [_{PolP} þessum hring [_{PolP} honum [_{Pol'} hafi [_{AGR_{SP}} Ólafur
Jon says that this ring it has Olafur
*lofað Maríu]]]]]
*promised Mary**
- (Icelandic: adapted from Thráinsson 1979: 64 with the brackets added by M.K.)

Note that the pronoun in (41)b is neither a clitic nor a weak pronoun. It is a strong pronoun bearing stress. If the weak form is used instead, the sentence becomes ungrammatical, as shown in (42).

- (42) *Jón segir [_{CP} að [_{PolP} þessum hring [_{PolP} 'onum [_{Pol'} hafi [_{AGR_{SP}} Ólafur
Jon says that this ring it (weak form) has Olafur
*lofað Maríu]]]]]
promised Mary (Icelandic: Höskuldur Thráinsson, personal communication)*

This suggests that the pronoun in (41)b occupies a position for a full phrasal category (i.e. XP) rather than a position for X⁰ or sub-X⁰ category. This conclusion is reinforced by the fact that an epithet may occur in place of the pronoun.⁷

⁷ The example in (43) is taken from Zaenen (Zaenen 1985: 46) with the brackets added by the present author. Zaenen reports that epithets are more natural in main clauses. Thus, while not everybody is totally happy with (43), everybody accepts (i).

(→ *continue*)

- (43) Jón segir [CP að [PolP Ólaf [PolP þetta fífl [Pol' elski [AGRsP hún ekki]]]]
John says that Olaf that fool loves she not

As far as I know, sentences comparable to (41) are ungrammatical in Danish and Swedish.

Researchers such as Diesing (1990) and Iatridou & Kroch (1993) have proposed to account for the contrast between (35) and (36) by postulating different structures for embedded V2 in these two types of languages (cf. also Santorini 1992). They claim that the V2 in Yiddish and Icelandic occurs in the domain of IP as in (44)a, while the V2 in Danish and Frisian involves CP recursion as in (44)b.

- (44) Non-uniform Analysis of Embedded V2 (Iatridou and Kroch 1993, etc.):
 a. Yiddish/Icelandic: ... [CP C [IP XP [I' V [... t ... t ...]]]]
 b. Danish/Frisian: ... [CP C [CP XP [C' V [... t ... t ...]]]]

There are several problems with this analysis. First, in (44)a, the "topic" phrase is in the Spec of Infl. Under the standard assumptions, the Spec of Infl is the position for the subject. Thus, non-subjects such as the object should not be able to occur in this position. In fact, Jonas & Bobaljik (1993) show that in Icelandic, definite subjects must raise to the Spec of AGRs by the time of SPELL-OUT. This means that the embedded subject in (33)b, repeated here as (45), is in the Spec of AGRs (= Infl) at "S-structure".

- (45) Jón segir að þessum hring hafi Ólafur lofað Maríu. (Icelandic)
Jon says that this ring has Olaf promised Mary

Thus, the pre-verbal object in this sentence cannot be located within the domain of IP. Second, even if we grant, for the sake of the argument, that the Spec of Infl can be an A-bar position for the "topic" phrase as in (44)a, it would not help at all, because then extraction from within the IP necessarily crosses a potential A-bar landing site (the Spec of Infl), which should yield a violation of the MLC. It will be thus incorrectly predicted that Yiddish-type languages do not allow extraction out of embedded clauses with verb-second

-
- (i) Ólaf, fetta fífl elski hún ekki
 Olaf that fool loves she not

word order. For these reasons, I will not adopt the non-uniform analysis (44). See Vikner (Vikner 1991) for further arguments against it.⁸

2. Multiply-Layered Specifiers

We have seen in the previous section that some categories may have two specifier positions. In this section, we will discuss cases in which a single head may have indefinitely many specifier positions.

⁸ We have seen that in cases like (i), the extraction across a filled Spec is made possible by layered specifiers, in which the upper Spec serves as an "escape hatch".

- (i) a. Which books_i did Becky say that [_{PolP} t_i' [only to Aaron [will she give t_i]]]
b. Vos_i hot er nit gevolt az [_{PolP} t_i' [in shul zoln [d: kinder leynen t_i]]]
what has he not wanted that in school shall the children read
(Yiddish: Santorini 1989: 59)

Thus, embedded V2 clauses in these languages do not constitute a syntactic island. Somewhat surprisingly, however, adjunct extraction out of these embedded clauses yields a high degree of deviancy, as shown in (ii).

- (ii) a. * How_i did Becky say that [only to Aaron will she give this kind of book t_i]
b. * Viazoy_i hot zi gezogt [az in shul hobn di kinder gelernt geshikhte t_i]
how has she said that in school have the children learned history
(Yiddish: Vikner 1991: 118)

Since there should be no island violations in these examples, their unacceptability must be explained in other terms. In this connection, consider the following well-known argument/adjunct asymmetry.

- (iii) a. * How do you wonder [whether John said [Mary solved the problem t]]?
b. ?? Who do you wonder [whether John said [t solved the problem]]?
(iv) a. * How didn't you behave t?
b. Which man didn't you invite?

To account for the contrast, a number of proposals have been made. They may be classified into three categories: syntactic accounts (Cinque 1990; Rizzi 1990; Chomsky and Lasnik 1993, among others), pragmatic accounts (Comorovski 1986; Kroch 1989, etc.), and formal semantic accounts (e.g. Szabolcsi and Zwarts 1992-1993). Among the three types of analyses, the latter two may be extended to cases like (ii), although exactly how is a topic for future research. See also Oka (1993a; 1993b), whose locality theory might be adapted to explain the contrast between (i) and (ii) syntactically.

2.1. Multiple WH Fronting

In Slavic and some other languages, all wh-phrases are preposed in overt syntax, as exemplified below.

- (46) a. Ne znaem **koj kakvo kade** e kupil (Bulgarian: Rudin 1988a)
not know who what where has bought
 'We don't know who bought what where.'
- b. Zavisi od tova, **kog kogo** prvu e udaril (Bulgarian: Boskovic 1993a)
depends on it who whom first is-cl hit
 'It depends on who hit whom first.'
- (47) a. **Ko kome koga** predstav!ja (Serbo-Croatian: Boskovic 1993a)
who (to)w_i om who is introducing
 'Who is introducing who to whom?'
- b. Zavisi od toga **ko koga** prvi udari? (Serbo-Croatian: Boskovic 1993a)
depends on it who whom first hits
 'It depends on who hits whom first.'

Among multiple wh-fronting languages, Bulgarian and Romanian allow extraction out of wh-islands, while Serbo-Croatian, Czech, etc. do not. This is shown in (48).

- (48) a. Koj se čudiš kakvo prodava?
who refl wonder-2sg what sells (Bulgarian: Izvorski 1993)
- b. * Šta si me pitao ko može da uradi?
what have-2s me asked who can to do
 'What did you ask me who can do?' (Serbo-Croatian: Rudin 1988b)

As discussed in Rudin (1988b) and others, multiple wh-fronting sentences in Bulgarian and Romanian have different structures than those in Serbo-Croatian and Czech. In the former, all wh-phrases are located to the left of a functional head (call it F) as in (49)a, while in the latter, only one wh-phrase occurs to the left of F, and the remaining wh-phrases appear after the position of F, as in (49)b.

- (49) Positions of Wh-phrases
- a. Bulgarian/Romanian: WH WH ... WH F
- b. Serbo-Croatian/Czech: WH F WH WH ...

Assuming that this is basically correct, I suggest that multiple wh-fronting sentences in these two types of languages have the structures in (50).

(50) Layered Specifiers Analysis of Multiple Wh-Fronting

a. Bulgarian/Romanian

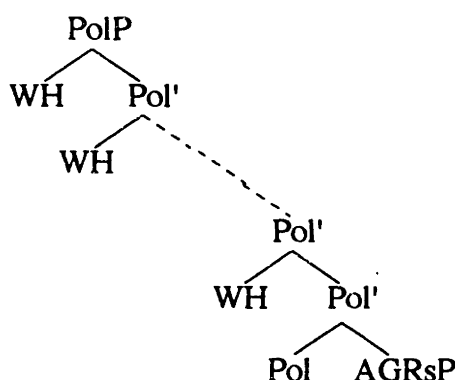

b. Serbo-Croatian/Czech

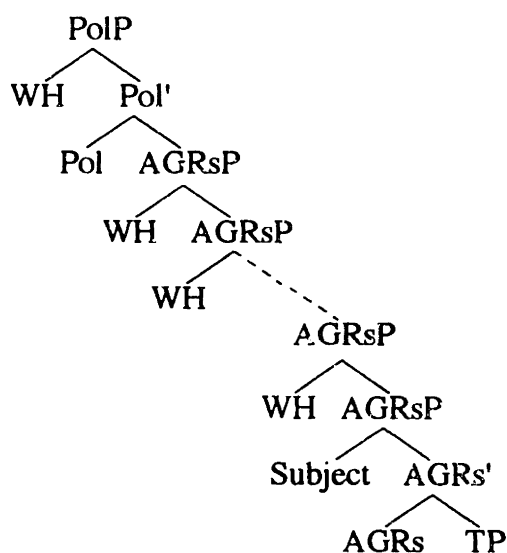

In Bulgarian-type languages, Pol has a feature that can license indefinitely many wh-phrases in its canonical specifier positions. Pol in Serbo-Croatian-type languages, in contrast, has a feature that can license only one wh-specifier position, but AGRs in these languages has a feature that can license indefinitely many wh-phrases in its adjoined specifier positions, in addition to Case and Agreement features that enter into checking relation with the subject in the canonical Spec. The feature of Pol that attracts a wh-phrase is a [+wh] operator feature, but the feature of AGRs that attracts wh-phrases seems to be different. The overt movement of wh-phrases in Serbo-Croatian-type languages is more like scrambling than wh-movement (Zeljko Boskovic, personal communication).

Under this analysis, (51)a has a structure like (51)b at the point of SPELL-OUT.

(51) a. Koga je kako Petar istukao (Serbo-Croatian)

Whom is how Peter beaten

b. [PolP whom_i ... ([AGRsP t_i] [AGRsP how [AGRsP ... t_i ...]) (I)]

↑ _____ (I) _____ ↓

Whom in (51)b crosses *how* in the adjoined Spec of AGRs. If the adjoined specifiers of AGRs is A-bar positions, *whom* has to stop by, for locality reasons, at an adjoined Spec of

AGRs higher than *how*. If the adjoined specifiers of AGRs are A-positions, *who* may move to the Spec of Pol in one fell swoop.

Turning back to (48), consider (52).

(52) a. Bulgarian (48)a:

$$\sqrt{\text{WH}_i \dots [\text{PolP } t_i' [\text{Pol}' \text{WH}_j \text{Pol} [\text{AGRsP} \dots t_j \dots t_i \dots]]]}$$

$$\uparrow \quad \text{(ii)} \quad | \quad \text{(i)} \quad |$$

b. Serbo-Croatian (48)b:

$$* \text{WH}_i \dots [\text{PolP } \text{WH}_j \text{Pol} ([\text{AGRsP } t_i') [\text{AGRsP} \dots t_j \dots t_i \dots] (I)]$$

$$\uparrow \quad \text{(i)} \quad \text{(II)} \quad |$$

The case in (52)b is a typical example of wh-island violation: the link (i) violates the MLC, because it skips a potential landing site, i.e. the Spec of the embedded Pol. (48)b is therefore ungrammatical. On the other hand, since Bulgarian Pol allows multiple specifier positions, when a wh-phrase is extracted out of a wh-island, it can use a Spec of Pol as an escape hatch, as in (52)a. In this structure, the MLC is not violated, because the two specifier positions of the embedded Pol are equidistant from any other position. (48)a is thus grammatical. This is another example of A-bar movement saved by layered specifiers and equidistance.⁹

The hypothesis that the landing site of wh-movement in Bulgarian-type languages is a Spec of Pol, as opposed to a Spec of C, is supported by the fact that wh-movement in Bulgarian induces Subject-Verb inversion both in matrix wh-questions as well as in

⁹ Rudin (1988b) argues that in Bulgarian and Romanian, all wh-phrases fronted to the clause initial position are in the single Spec of CP. The first wh-phrase substitutes the Spec of CP, and the remaining ones adjoin to the Spec position from the right. Besides several theoretical questions (e.g., why do wh-phrases right-adjoin to the Spec of CP, instead of more usual left-adjunction?), none of her evidence for single constituency is convincing. For instance, Rudin cites, as evidence for her claim, the fact that adverbs may not intervene between the fronted wh-phrases. However, this has a straightforward explanation under the layered specifiers analysis: adverbs intervening between the wh-phrases would incorrectly enter into the checking relation with [+wh] Pol. Her strongest argument has to do with Superiority effects, for which she presents an ECP account. Again, it has been challenged on empirical grounds (cf. Boskovic 1993b; Cheng 1991).

embedded indirect wh-questions, as illustrated by the following examples taken from (Izvorski 1993):¹⁰

(53) a. Koe pismo napisa dete-to
 which letter wrote child-the
 'which letter did the child write?'

b. * Koe pismo dete-to napisa
 which letter child-the wrote

(54) a. Tja me popita kâde živee Ivan
 she me asked where lives Ivan
 'She asked me where Ivan lives.'

b. * Tja me popita kâde Ivan živee
 she me asked where Ivan lives

This is analogous to the obligatory Subject-AUX inversion in the cases of negative preposing and matrix wh-question in English, which we have seen occurs in the domain of Pol. Another piece of supporting evidence for the proposed analysis has to do with the relative order of the topic and wh-phrases. As shown in (55), the topic in Bulgarian occurs between C and the subject, and it does not induce Subject-Verb inversion.

(55) Kazaha :ni, ťe na Maria Ivan e posvetil tri ot knigite si.
 told-sp.pl me that to Maria Ivan is dedicated-m.sg three of books refl.

(Izvorski 1993)

This is exactly like the topic in English, suggesting that the topic in Bulgarian, like the topic in English, occupies the adjoined Spec of Pol. Wh-phrases occur to the right of the topic, as exemplified below.

(56) a. Popitah go novata si kniga na kogo ťte posveti
 asked-1sg him the-new refl. book to whom will dedicate
 'I asked him to whom he will dedicate his new book.'

¹⁰ The arguments in this paragraph are based on those in Izvorski (1993) for a similar point. Cf. also Toyoshima (1991).

- b. **Ivan za kogo e kupil cvetja-ta?**
Ivan for whom is bought-m.sg. flowers-the

(Izvorski 1993)

This is readily explained if we assume that Pol has a *wh*-feature for the canonical Spec and a topic feature for the adjoined Spec, analogous to the following English case we have seen earlier.

- (57) And a book like this, to whom would you give? (Delahunty 1983)

Interestingly, relative pronouns occur to the left of the topic, suggesting that they occupy the Spec of C.

- (58) **Vreme-to, kogato knigite si Ivan gi posvestavaše na Maria, otmina**
time-the *when* **books refl.** Ivan them dedicated to Maria passed
'The time when Ivan used to dedicate his books to Maria is now gone.'

(Izvorski 1993)

The layered specifiers discussed in this subsection are different from the layered specifiers of English type. In the case of English Pol, the elements in the two specifiers bear different features, i.e. Top and Neg, and the number of the specifier positions is limited to at most two. We thus hypothesized that the head Pol has two different features, one for the canonical Spec and one for the adjoined Spec. In the case of multiple *wh*-fronting, in contrast, all the elements in the specifier positions of the relevant category bear the same kind of feature, i.e. the feature that induces movement of *wh*-phrases, and the number of specifier positions per head seems to have no upper limit. It is highly unlikely that [+*wh*] Pol in Bulgarian, for example, has an indefinite number of features to license *wh*-phrases in its Spec positions. I suggest that in the case of multiple *wh*-fronting of the type in question, the relevant functional head (e.g. Pol) has a single feature that can enter into the checking relation with indefinitely many *wh*-phrases. *Wh*-phrases in languages like Bulgarian move overtly because they have a strong feature to be checked against a feature of Pol that may undergo more than one checking. In single *wh*-fronting languages

like English, Pol (or C) has a strong wh-feature, and wh-phrases have weak wh-features. Thus, it suffices for a single wh-phrase to overtly move into the Spec of Pol (or C).¹¹

To summarize, there are two different "sources" of layered specifiers. Double-layered specifiers arise when the relevant head has two slots in its feature grid for specifiers, one for the canonical Spec and one for the adjoined Spec. In contrast, multiply-layered specifiers are possible when the relevant head has a feature that can be checked more than once, in fact indefinitely many times. The latter type of feature may be for the canonical specifier positions as in the case of Bulgarian-type languages, or it may be for the adjoined specifiers as in the case of Serbo-Croatian-type languages. In the next subsection, we will see another instance of multiply-layered specifiers.

2.2. Multiple Subjects

According to Ura (1994a), there is a strong correlation between the presence of the multiple subject construction in a language and the possibility of superraising in that language:

(59) Ura's Generalization

If a language allows the so-called "Multiple Subject Construction", then it also allows superraising to take place.

(Ura 1994a: 5)

For example, it is reported in Ura (1994a) that Indonesian has both constructions, whereas English has neither.

(60) Indonesian

a. Multiple subjects

Rumah itu atapnya bocor. (Ura 1994a: 34)

house the-NOM roof-3SG-NOM leaks

Lit. 'The house, (its) roof leaks.'

¹¹ I assume that wh-features of wh-phrases in situ (which are weak) adjoin to C in LF without pied-piping the whole wh-phrases (cf. Chomsky (Class lectures, Fall 1994)). See Tsai (1994) for an alternative analysis of WH in situ, which is also compatible with our proposals made in this chapter.

b. Superraising

Tini_i di-anggap [behwa saja beri-Ø sura itu t_j] (Ura 1994a: 10)

Tini PASS-believe COMP I give letter the

Lit. 'Tini_i is believed that I gave t_j the letter.'

(They believe that I gave the letter to Tini.)'

(61) English

a. Multiple subjects

* I doubt that the house, its roof leaks.

b. Superraising

* John_i seems [that it was told t_j [that Mary is a genius]]

A commonly assumed account of the ungrammaticality of (61)b is that the movement of *John* across the embedded subject *it* violates some version of Relativized Minimality (cf. Rizzi 1990; Chomsky and Lasnik 1993; Chomsky 1993b).

To account for the generalization in (59), Ura (1994a) suggests that in languages with multiple subject constructions, AGRs has a feature that can license multiple A-specifier positions, and all the "subjects" in the multiple subject construction are in these positions:

(62) [AGRsP Subject₁ [Subject₂ ... [Subject_n AGRs [TP ...]]]]

In a superraising sentence like (60), the raised element may use a Spec of the embedded AGRs as an escape hatch, as shown in (63).

(63) Tini_i ... [AGRsP t_i' [Subject AGRs [TP ... t_j ...]]]

In this structure the superraising is possible because the specifier position occupied by *t_i'* and the specifier position occupied by the embedded subject are equidistant from any other positions as they are both in the checking domain of the embedded AGRs. The same operation is not allowed in English because English AGRs has only one specifier position.

If this analysis of the multiple subject construction and the superraising is correct, then we have evidence that layered specifiers are possible in the A-system as well as the A-bar system.

3. Double-Multiply-Layered Specifiers

Japanese has very productive multiple subject constructions (cf. Kuno 1973). An example is given below.

- (64) Bunmeekoku-ga dansee-ga heekin-zyumyoo-ga nagai
civilized country-NOM male-NOM average-life span-NOM long
'It is in civilized countries that men -- their average life-span is long.'
(It is the average life-span of civilized countries that is long.)

In this sentence, the third nominative NP is the notional subject of the predicate. The nominative (subject) NPs other than the notional subject are often referred to as "major subjects", and they occur to the left of the notional subject. According to Ura (1994a), Japanese has (covert) superraising in accordance with the generalization in (59). This means that AGRs in Japanese allows layered specifiers, and (64) has a schematic structure like (65).

- (65) [AGR_{sP} civilized country-NOM [male-NOM [average-life span-NOM [TP ...] ...]]]

Since all the "subjects" (notional as well as major ones) are in the checking domain of AGRs, their Cases are licensed by the Case-feature of T copied to AGRs.

We have seen in Chapter 4 that the object of stative predicates bears nominative Case. An example is repeated below.

- (66) John-ga eego-ga dekiru.
John-NOM English-NOM capable
Lit. 'John is capable of English.' (John speaks English).

As I suggested there, the nominative Case feature of the object, along with other formal features, raises to AGRs at LF for the purpose of Case-checking (AGRs-adjoined positions are in the checking domain of AGRs). The following sentence exemplifies all three kinds of nominative NPs.

(67) John-ga imooto-ga huransugo-ga hanas-e-ru

John-NOM younger.sister-NOM French-NOM speak-can-PRES

'It is John whose sister can speak French.'

The first NP is a major subject, the second NP a notional subject, and the third one a nominative object. They are all marked with the nominative marker *ga* in standard Japanese.

The situation is slightly different in Kumamoto Japanese, a dialect of Japanese spoken in the middle part of Kyushu. Consider the following pairs of the multiple subject sentences.¹²

(68) a. Standard Japanese

Natu-ga kankookyaku-ga ooi
summer-NOM tourist-NOM numerous

'It is summer when tourists are numerous.'

b. Kumamoto Japanese

Natu-ga kankookyaku-no ookabai (Yoshimura 1994a)
summer-NOM tourist-GEN numerous

(69) a. Standard Japanese

Nippon-ga otoko-ga zyumyoo-ga nagai
Japan-NOM man-NOM life.span-NOM long

'It is Japan in which men's life span is long.'

(Japanese men have a long life span.)

b. Kumamoto Japanese

Nippon-ga otoko-ga zyumyoo-no nanka (Yoshimura 1992: 106)
Japan-NOM man-NOM life.span-GEN long

Both the (notional) subject and the major subject are marked with the nominative *ga* in standard Japanese. In Kumamoto Japanese, in contrast, the subject is marked with the

¹² I would like to thank Koji Fujita for pointing me to Yoshimura (1994a). All the examples of Kumamoto dialect used in this chapter are those of Yatsushiro branch of Kumamoto Japanese. In the Yatsushiro dialect, *no* becomes *n* after vowels, an effect which is glossed over in our transcriptions.

genitive *no* (whether or not the major subject cooccur), though the major subject is marked with *ga* as in the case of standard Japanese. According to Yoshimura (1992; 1994a), the other logically possible combinations of case marking yield ungrammaticality. This is shown in (70).¹³

- (70) a. * Natu-ga kankookyaku-ga ookabai
summer-NOM tourist-NOM numerous
- b. * Natu-no kankookyaku-no ookabai
summer-GEN tourist-GEN numerous
- c. * Natu-no kankookyaku-ga ookabai
summer-GEN tourist-NOM numerous

This indicates that Kumamoto Japanese discriminates the canonical specifier position from specifier positions above the canonical Spec, for the purpose of Case-licensing. Noun Phrases in non-canonical specifier positions of AGRs are marked with *ga*, and an NP in the canonical Spec of AGRs is marked with *no*. Elsewhere (Koizumi 1994a) I have stated this observation as follows.

- (71) Kumamoto Japanese:
- a. An NP is marked with *ga* only if it is Case-licensed in the *Broad Checking Domain* of AGRs.
- b. An NP is marked with *no* only if it is Case-licensed in the *Narrow Checking Domain* of Tense.¹⁴

Informally speaking, the narrow checking domain of AGRs is that part of the checking domain dominated by AGRsP, and the broad checking domain is the checking domain minus the narrow checking domain (i.e. that part of checking domain contained in, but not dominated by, AGRsP). See Koizumi (1994a) for formal definitions.

¹³ (70)b-c are grammatical if the first genitive NP is taken to be a part of the subject NP, as in [*NP [NP natu]-no kankookyaku]-no* "(the) summer's tourists", although they are still semantically unnatural.

¹⁴ (71)ii obviously ignores *no*-marking within NPs (or DPs).

Now the generalization in (71), coupled with our claim that the Case-feature of the "nominative" object is checked at the AGRs-adjoined position, correctly predicts that the "nominative" object in Kumamoto Japanese is marked with the genitive *no*, like the subject in this language. The other combinations of *ga/no* lead to ungrammaticality.¹⁵

- (72) a. An ozisan-no eego-no hanas-e-ru ka
that man-GEN English-GEN speak-can-PRES Q
 'Can that man speak English?'
- b. * An ozisan-no eego-ga hanas-e-ru ka
that man-GEN English-NOM speak-can-PRES Q
- c. * An ozisan-ga eego-no hanas-e-ru ka
that man-NOM English-GEN speak-can-PRES Q
- d. * An ozisan-ga eego-ga hanas-e-ru ka
that man-NOM English-NOM speak-can-PRES Q

I suggest that T in Kumamoto Japanese has two Case features [Nom] and [Gen]. They are copied to AGRs when T adjoins to it. [Gen] is for the canonical Spec of AGRs, and [Nom] for the adjoined specifier positions of AGRs.¹⁶ Both Case features have the ability to check multiple elements.

4. Conclusion

In this chapter, I have argued (i) that some categories may have more than one specifier position (layered specifiers), and (ii) that equidistance applies not only to A-movement but also to A-bar movement (cf. Branigan 1992). If these conclusions, especially (i), turn out to be correct, the standard X'-schema in (1) must be dismissed, along with more restricted theories of phrase structure such as Kayne's (1994). The bare phrase structure theory is compatible with our result in that it does not stipulate the number of projections per head across categories cross-linguistically. The number of specifiers of a

¹⁵ I owe the examples in (72) to Noriko Yoshimura (personal communication). See also Yoshimura (1994b).

¹⁶ Since feature-checking is done not only at specifier positions but also at the positions adjoined to a head, the feature for the narrow checking domain and the feature for the broad checking domain, respectively, may be better names than the feature for the canonical Spec and the feature for the adjoined Spec.

category seems to be determined primarily by two factors: i) whether a category has a feature slot for adjoined Spec, and ii) whether a Spec feature can enter into the checking relation with multiple elements. The category Pol in English, for example, has two slots, and the Bulgarian wh-feature in Pol can be checked indefinitely many times. To what extent the distribution of layered specifiers in a language is predictable from other properties of the language is an empirical question, and we must leave it for future research.¹⁷

¹⁷ One area for which a layered specifier analysis seems promising is where wh-island effects are weak or non-existent (e.g. Italian -- Rizzi 1982; Adams 1984-85; Icelandic -- Maling 1978; Maling and Zaenen 1978; Hebrew -- Reinhart 1982).

CHAPTER SEVEN

STRING VACUOUS OVERT VERB RAISING

Since Pollock (1989), it has been hotly debated whether verbs in a language raise to some functional head position in overt syntax or stay in their original positions. Japanese is no exception. For example, using some interpretive facts about a "VP-deletion-like" construction, Otani and Whitman (1991) argue that verbs in Japanese move out of the VP by LF. The validity of their arguments, however, has been questioned by Hoji (1994), who maintains that the issue has not been settled yet.¹ The difficulty of the question concerning the timing of verb raising in Japanese lies, in part, in the fact that it is an

¹ Japanese examples with an object gap such as (ib) are ambiguous between the two readings given below.

- (i) a. John-wa [zibun-no tegami]-o sute-ta.
John-TOP self-GEN letter-ACC discard-PAST
'John_i threw out self_i's letters.'
- b. Mary-mo [e] sute-ta.
Mary-also discard-PAST
'= Mary_j also threw out self_j's letters.'
'= Mary also threw out John's letter.'

Following a hypothesis due to Huang (1987a; 1987b), Otani & Whitman (1991) argues that the ambiguity of (ib), especially the availability of the first reading ("sloppy reading"), suggests that the verb raises out of the VP, creating an empty VP analogous to the empty VP in the English example (iib), whose ambiguity is to be accounted for along the lines of Sag (1976) and Williams (1977a).

- (ii) a. John threw out his letters.
b. Mary did [[e]_v [e]_{NP}]_{VP} too.

Presenting various kinds of counterexamples to Otani & Whitman's analysis, Hoji (1994) convincingly shows that the first reading of (ib) is not a genuine sloppy reading one can find with the VP deletion constructions such as (iib). Hoji argues that such a reading arises from two different ways, neither of which requires V-raising. If Hoji (1994) is correct, the examples like (ib) have no bearing on the issue of V-raising. Besides, Otani & Whitman's (1991) analysis, if correct, only indicates that the verb raises out of the VP before LF interpretive rules (such as Williams' Derived VP rule) apply. Thus, strictly speaking, it does not show that the verb raises before SPELL-OUT. The latter remark also applies to the arguments for verb raising presented in Whitman (1991).

absolute head final language. By "absolute head final languages", I mean head final languages that do not allow any right adjunction or rightward XP movement. Since Japanese is an absolute head final language in this sense, neither arguments nor adjuncts can occur between head positions in this language. Simple word order facts therefore tell us virtually nothing about verb raising. The same point holds of other absolute head final languages such as Korean.

The purpose of this chapter is to present direct evidence for overt verb raising in Japanese, that does not suffer from criticisms raised against indirect arguments previously presented for or against it. The issue is important because i) practically no convincing evidence has been found for overt verb raising in absolute head final languages despite that evidence is abundant for syntactic verb raising in head initial languages, and ii) the validity of a number of influential works on Japanese syntax such as Saito (1992), Tada (1993), and Miyagawa (1994) directly hinges on the timing of verb raising.

In §1, I adduce evidence to show that verbs in Japanese raise out of the VP in overt syntax. In §2, I discuss apparent alternative analyses of some of the data presented in §1. Finally, in §3, I explore consequences of the overt verb raising analysis of Japanese to various aspects of syntactic theory such as the proper binding condition and Kayne's (1994) Linear Correspondence Axiom.

1. Overt Verb Raising in Japanese

In this section, I will show that verbs in Japanese move out of the VP before SPELL-OUT.

1.1. Clefting

The first piece of evidence comes from facts about clefting. As shown in (1), "indirect object + direct object" may be clefted, with the verb being stranded.

- (1) a. *Mary-ga John-ni ringo-o 3-tu age-ta (koto)*
Mary-NOM John-to apple-ACC 3-CL give-PAST (fact)
 'Mary gave three apples to John.'
- b. *Mary-ga age-ta no-wa [John-ni ringo-o 3-tu] da*
Mary-NOM give-PAST NL-TOP [John-to apple-ACC 3-CL] be
 Lit. 'It is [three apples to John] that Mary gave.'

(1)a is a regular ditransitive sentence, and (1)b is its cleft counterpart with the indirect object and direct object in the focus position. Assuming, as is standard, that the base-positions of the verb and the direct object are sisters to each other, these sentences suggest that the verb overtly moves out of the VP that dominates the direct and indirect objects, as schematically shown in (2). It is this "remnant" VP (or some larger phrase) that is clefted in (1)b.²

- (2) Schematic structure of (1)a
 Subject [VP IO DO t_v] V Tense
 |__↑

Similarly (3) and (4) suggest that the verb raises even higher than the subject, probably to C.³

- (3) a. Mary-ga ringo-o 3-tu kat-ta (koto)
 Mary-NOM apple-ACC 3-CL buy-PAST
 'Mary bought three apples.'
 b. Kat-ta no-wa [Mary-ga ringo-o 3-tu] da
 buy-PAST NL-TOP [Mary-NOM apple-ACC 3-CL] be
 Lit. 'It is [Mary three apple] that bought.'
- (4) a. Mary-ga John-ni ringo-o 3-tu age-ta (koto) (= (1)a)
 Mary-NOM John-to apple-ACC 3-CL give-PAST
 'Mary gave three apples to John.'
 b. Age-ta no-wa [Mary-ga John-ni ringo-o 3-tu] da
 give-Past NL-TOP [Mary-NOM John-to apple-ACC 3-CL] be
 Lit. 'It is [Mary three apples to John] that gave.'

² Under the Split VP Hypothesis proposed in Chapter 5, the focused constituent in (1)b can be any of the following: TP, V^{UP}, AGR_{IO}P, AGR_{OP}, and V^{IP}.

We will not be concerned with the exact structure of the cleft construction in Japanese here. See Appendix B for discussion.

³ I assume with Nemoto (1993) and others that the subject in Japanese raises to the Spec of I (or AGRs) in overt syntax.

In the following examples, "IO + DO" and "S + O" of the embedded clauses are clefted. This shows that overt V-Raising takes place in embedded clauses as well.⁴

- (5) a. Mary-ga [John-ga Becky-ni ringo-o 3-tu ageta to] itta
Mary-NOM [John-NOM Becky-to apple-ACC 3-CL gave that] said
 'Mary said that John gave three apples to Becky.'
- b. Mary-ga [John-ga ageta to] itta no-wa [Becky-ni
Mary-NOM [John-NOM gave that] said NL-TOP [Becky-to
 ringo-o 3-tu] da
apple-ACC 3-CL] be
 Lit. 'It is [three apples to Becky] that Mary said that John gave.'
- (6) a. Mary-ga Nancy-ni [John-ga ringo-o 3-tu katta to] itta
Mary-NOM Nancy-to [John-NOM apple-ACC 3-CL bought that] said
 'Mary said to Nancy that John bought three apples.'
- b. Mary-ga Nancy-ni [katta to] itta no-wa [John-ga
Mary-NOM Nancy-to [bought that] said NL-TOP [John-NOM
 ringo-o 3-tu] da
apple-ACC 3-CL] be
 Lit. 'It is [John three apples] that Mary said to Nancy that bought.'

Now, note that, as shown in (7), it is not possible to cleft the matrix arguments along with the constituents of the embedded clause.

- (7) a. Mary-ga Nancy-ni [John-ga ringo-o 3-tu katta to] itta
Mary-NOM Nancy-to [John-NOM apple-ACC 3-CL bought that] said
 'Mary said to Nancy that John bought three apples.'
- b. * Katta to itta no-wa [Mary-ga Nancy-ni John-ga
bought that said NL-TOP [Mary-NOM Nancy-to John-NOM
 ringo-o 3-tu] da
apple-ACC 3-CL] be
 Lit. 'It is [Mary Nancy John three apples] that said that bought.'
 (Mary said to Nancy that John bought three apples.)

⁴ The example in (5)b is due to Mamoru Saito (personal communication).

The ungrammaticality of (7)b shows two points: i) overt V-Raising does not cross tensed clause boundaries, and ii) the clefting in Japanese operates *not* on a linear sequence of words, but rather on a syntactic constituent. As a further support of the syntactic nature of the cleft construction, clefting of remnant VP/IP obeys Subjacency.⁵

- (8) a. Mary-ga [[John-ga Becky-ni ringo-o 3-tu ageta] zikan]-o
Mary-NOM [[John-NOM Becky-to apple-ACC 3-CL gave] time]-ACC
 siritagatteiru.
want.to.know
 'Mary wants to know the time when John gave three apples to Becky.'
- b. * Mary-ga [[John-ga ageta] zikan]-o siritagatteiru no-wa
Mary-NOM [[John-NOM gave] time]-ACC want.to.know NL-TOP
 [Becky-ni ringo-o 3-tu] da
[Becky-to apple-ACC 3-CL] be
 Lit. 'It is [three apples to Becky] that Mary wants to know the time when John gave'
- (9) a. Mary-ga Nancy-*ni* [[John-ga ringo-o 3-tu katta] mise]-o
Mary-NOM Nancy-to [[John-NOM apple-ACC 3-CL bought] store]-ACC
 osieta
told
 'Mary told Nancy the store at which John bought three apples.'
- b. * Mary-ga Nancy-*ni* [[katta] mise]-o osieta no-wa
Mary-NOM Nancy-to [[bought] store]-ACC told NL-TOP
 [John-ga ringo-o 3-tu] da
.John-NOM apple-ACC 3-CL] be
 Lit. 'It is [John three apples] that Mary told Nancy the store at which bought.'
- (10) a. Mary-ga [[John-ga ringo-o 3-tu taberu] mae-ni] kaetta
Mary-NOM [John-NOM apple-ACC 3-CL eat] before] left
 'Mary left before John ate three apples.'

⁵ See Hoji (1987) and Murasugi (1991) for the locality of regular cleft constructions in Japanese.

- (13) [[Mary-ga ringo-o 2-tu] to [Nancy-ga banana-o 3-bon]]
 [[Mary-NOM apple-ACC 2-CL] and [Nancy-NOM banana-ACC 3-CL]]
 tabeta (koto)

ate

Lit. '[Mary two apples] and [Nancy three bananas] ate.'

(Mary ate two apples, and Nancy three bananas.)

- (14) [[Mary-ga John-ni ringo-o 2-tu] to [Nancy-ga Bob-ni
 [[Mary-NOM John-to apple-ACC 2-CL] and [Nancy-NOM Bob-to
 banana-o 3-bon]] ageta (koto)

banana-ACC 3-CL]] gave

Lit. '[Mary two apples to John] and [Nancy three bananas to Bob] gave.'

(Mary gave two apples to John, and Nancy gave three bananas to Bob.)

These observations confirm the claim that verbs in Japanese raise to C in overt syntax.⁷

The following examples with coordination of embedded VPs/IPs further show that verbs of embedded clauses also move out of the VP before the derivation branches off to PF.

-
- (iii) ? [[Mary-ga John-ni ringo-o 2-tu] to [Bob-ni Nancy-ga ti
 [[Mary-NOM John-to apple-ACC 2-CL] and [Bob-to Nancy-NOM ti
 banana-o 3-bon]] ageta (koto)
banana-ACC 3-CL]] gave (the fact)

Lit. '[Mary two apples to John] and [Nancy three bananas to Bob] gave.'

(Mary gave two apples to John and Nancy gave three bananas to Bob.)

⁷ The unacceptability of the following examples may indicate that the position of the verb at the point of SPELL-OUT is lower than the topic.

- (i) ?* Mary-wa ringo-o 2-tu to Nancy-wa banana-o 3-bon
 Mary-TOP apple-ACC 2-CL and Nancy-TOP banana-ACC 3-CL
 tabeta (koto)
ate (the fact)

Lit. '[Mary two apples] and [Nancy three bananas] ate.'

(Mary ate two apples and Nancy ate three bananas.)

The example becomes acceptable if *to* "and" is replaced with the other conjunctive particle *sosite* "and". See Appendix A for the reason why *sosite* cannot be used for our purposes.

- (15) Nancy-ga [Mary-ga [[John-ni ringo-o 2-tu] to [Bob-ni
Nancy-NOM [Mary-NOM [[John-to apple-ACC 2-CL] and [Bob-to
banana-o 3-bon]] ageta to] omotteiru (koto)
banana-ACC 3-CL]] gave that] believe
 'Nancy believes that Mary gave two apples to John and three bananas to Bob.'
- (16) Becky-ga [[[Mary-ga ringo-o 2-tu] to [Nancy-ga banana-o
Becky-NOM [[[Mary-NOM apple-ACC 2-CL] and [Nancy-NOM banana-ACC
3-bon]] tabeta to] omotteiru (koto)
3-CL]] ate that] believe
 Lit. 'Becky believes that [[Mary two apples] and [Nancy three bananas] ate.'
 (Becky believes that Mary ate two apples and Nancy three bananas.)

As expected, the matrix arguments may not occur in the same conjunct as the embedded arguments, for the embedded verb does not raise to the matrix clause across a tensed clause boundary:

- (17) * [[Mary-ga John-ga ringo-o 2-tu] to [Nancy-ga Bob-ga
[[Mary-NOM John-NOM apple-ACC 2-CL] and [Nancy-NOM Bob-NOM
banana-o 3-bon]] katta to omotteiru (koto)
banana-ACC 3-CL]] bought that believe
 Lit. '[[Mary John two apples] and [Nancy Bob three bananas]] believes that
 bought.'
 (Mary believes that John bought two apples, and Nancy believes that Bob
 bought three bananas.)

The overt V-Raising analysis is further supported by the fact that the coordinate structures in (11), (13), and (14) may be clefted, as shown in (18) through (20), which lends credence to the proposed analysis of constituent structure of these sentences.

- (18) Mary-ga ageta no-wa [[John-ni ringo-o 2-tu] to (cf. (11))
Mary-NOM gave NL-TOP [[John-to apple-ACC 2-CL] and
[Bob-ni banana-o 3-bon]] da
[Bob-to banana-ACC 3-CL]] be
 Lit. 'It is [two apples to John and three bananas to Bob] that Mary gave.
 (Mary gave two apples to John and three bananas to Bob.)

- (19) Tabeta no-wa [[Mary-ga ringo-o 2-tu] to (cf. (13))
ate NL-TOP [[Mary-NOM apple-ACC 2-CL] and
 [Nancy-ga banana-o 3-bon]] da
[Nancy-NOM banana-ACC 3-CL]] be
 Lit. '[Mary two apples] and [Nancy three bananas] ate.'
 (Mary ate two apples and Nancy ate three bananas.)
- (20) Ageta no-wa [[Mary-ga John-ni ringo-o 2-tu] to (cf. (14))
gave NL-TOP [[Mary-NOM John-to apple-ACC 2-CL] and
 [Nancy-ga Bob-ni banana-o 3-bon]] da
[Nancy-NOM Bob-to banana-ACC 3-CL]] be
 Lit. 'It is [Mary two apples to John and Nancy three bananas to Bob] that gave.'
 (Mary gave two apples to John and Nancy gave three bananas to Bob.)

Furthermore, the coordinate structures may undergo scrambling, as shown in (21) through (23).⁸

- (21) [[John-ni ringo-o 2-tu] to [Bob-ni banana-o 3-bon]]i (cf. (11))
[[John-to apple-ACC 2-CL] and [Bob-to banana-ACC 3-CL]]i
 Mary-ga t_i ageta (ko:o)
Mary-NOM t_i gave
 Lit. '(the fact that) [two apples to John and three bananas to Bob]_i Mary gave t_i.'
- (22) [[John-ni ringo-o 2-tu] to [Bob-ni banana-o 3-bon]]i (cf. (15))
[[John-to apple-ACC 2-CL] and [Bob-to banana-ACC 3-CL]]i
 Nancy-ga [Mary-ga t_i ageta to] omotteiru (koto)
Nancy-NOM [Mary-NOM t_i gave that] believe
 Lit. '[two apples to John and three bananas to Bob]_i Nancy believes that Mary gave t_i.'
 (Nancy believes that Mary gave two apples to John and three bananas to Bob.)
- (23) ? [[Mary-ga ringo-o 2-tu] to [Nancy-ga banana-o 3-bon]]i (cf. (16))
[[Mary-NOM apple-ACC 2-CL] and [Nancy-NOM banana-ACC 3-CL]]i

⁸ The example in (23) is not perfect, probably due to parsing difficulties. The matrix subject *Becky* tends to be incorrectly associated with the embedded verb when the sentence is parsed.

Becky-ga [t_i tabeta to] omotteiru (koto)

Becky-NOM [t_i ate that] believe

Lit. '[Mary two apples] and [Nancy three bananas] Becky believes that ate.'

(Becky believes that Mary ate two apples and Nancy three bananas.)

Again, this is evidence for the proposed constituent structure and the overt V-Raising analysis of sentences like (11).

2. Apparent Alternative Analyses

We have seen two kinds of evidence for overt verb raising in Japanese, clefting and coordination. Putting the cleft construction aside for the moment, there are two conceivable alternative analyses of the sentences with conjoined structures such as (11), (13), and (14): Gapping and Right-Node-Raising. If it turns out that they can account for all the data shown above, our argument for overt verb raising will be weakened. In this section, I will show that they make incorrect predictions about the constituent structure of the coordination sentences, hence the overt verb raising analysis is the only analysis that is compatible with all the data.

2.1. Gapping

Ross (1970) proposed the rule of Gapping, which derives (24)b from (24)a by deleting the verb in the second conjunct that is identical to the one in the first conjunct.

- (24) a. The boy works in a skyscraper and the girl works in a Quonset hut.
b. The boy works in a skyscraper and the girl in a Quonset hut.

According to this analysis, (24)b has the identical structure as (24)a, except that the second verb is elided, as shown in (25).

- (25) [[the boy works in a skyscraper] and [the girl ~~works~~ in a Quonset hut]]

If the Japanese coordination sentences we have discussed are derived by Gapping, the sentence in (13), for example, will have the structure in (27) rather than that in (26).

(26) Structure of (13) under the verb raising analysis

[[Mary-ga ringo-o 2-tu t_j] to [Nancy-ga banana-o 3-bon t_j]]

[[Mary-NOM apple-ACC 2-CL t_j] and [Nancy-NOM banana-ACC 3-CL t_j]]

tabeta_i

ate_i

Lit. '[Mary two apples] and [Nancy three bananas] ate.'

(Mary ate two apples and Nancy ate three bananas.)

(27) Structure of (13) under the Gapping analysis

[[Mary-ga ringo-o 2-tu ~~tabeta~~] to [Nancy-ga banana-o 3-bon

[[Mary-NOM apple-ACC 2-CL ~~ate~~] and [Nancy-NOM banana-ACC 3-CL

tabeta]]

ate]]

Lit. '[Mary two apples] and [Nancy three bananas] ate.'

(Mary ate two apples and Nancy ate three bananas.)

The crucial difference between the verb raising analysis in (26) and the Gapping analysis in (27) is that, in (26) the verb is outside the coordinate structure, whereas in (27) it is within the coordinate structure. In other words, under the verb raising analysis, the underlined part in (26) is a syntactic constituent, whereas under the Gapping analysis there is no such constituent. Thus, we expect that, if the verb raising analysis is correct, the underlined part may be affected by syntactic processes such as clefting and scrambling, without the verb being affected at the same time. On the other hand, if the Gapping analysis is correct, such processes should be impossible. We have already seen that the prediction of the verb raising analysis is the correct one. For example, in (19), the underlined part in (26) is the focus of the cleft construction, and in (23), it has undergone scrambling. Thus, the Japanese coordination sentences in question are not derived by Gapping in the sense of Ross (1970).⁹

⁹ Another possible problem with the Gapping analysis of the Japanese sentences in question is that, although the number of remnants in Gapping is usually limited to two (Jackendoff 1971), the Japanese coordination examples are completely acceptable with more than two remnants.

- (i) a. Becky loves Bob, and Joni Marty, too.
b. * Becky sent this book to Bob, and Joni that article to Marty.

(→continue)

2.2. Right-Node-Raising

According to the most common view of Right-Node-Raising, it applies to a coordinate structure whose conjuncts end with identical constituents, Chomsky-adjointing a copy of the common constituent to the right of the whole coordinate structure and deleting all the originals (cf. Ross 1970; Postal 1974). Under this view of RNR, (28) has the structure in (29).

- (28) Joan sells, and Fred knows a man who repairs, washing machines.
 (29) [[Joan sells t_i] and [Fred knows a man who repairs t_i] washing machines_j]
- 

It has been pointed out that this conception of RNR is problematic in several respects (McCawley 1982; 1987; Wexler and Culicover 1980; Levine 1984). To mention just one, if (29) is the correct structure, the NP *washing machines* is extracted from within the complex NP, violating the Complex NP Constraint. Nonetheless, the sentence does not have the oddity that normally accompanies CNPC violations (McCawley 1982; 1987). Generally the constituent raised by RNR behaves as if it were in its original position. For this reason, McCawley (1982; 1987) suggests that RNR in fact does not change domination relations, and its output contains a discontinuous constituent, as shown in (30).

-
- (ii) [[Mary-ga ototoi John-ni ringo-o 2-tu] to [Nancy-ga
 [[Mary-NOM two days ago John-to apple-ACC 2-CL] and [Nancy-NOM
 kinoo Bob-ni banana-o 3-bon]] ageta (koto)
 yesterday Bob-to banana-ACC 3-CL]] gave
 Lit. '[Mary apples to John two days ago] and [Nancy three bananas to Bob
 yesterday] gave.'
 (Mary gave two apples to John two days ago, and Nancy gave three bananas
 to Bob yesterday.)

In a recent paper (Johnson 1994), Kyle Johnson suggested that Gapping sentences such as (24)b are derived by across-the-board verb raising. Our analysis, of course, is compatible with this analysis of Gapping phenomena.

(30)

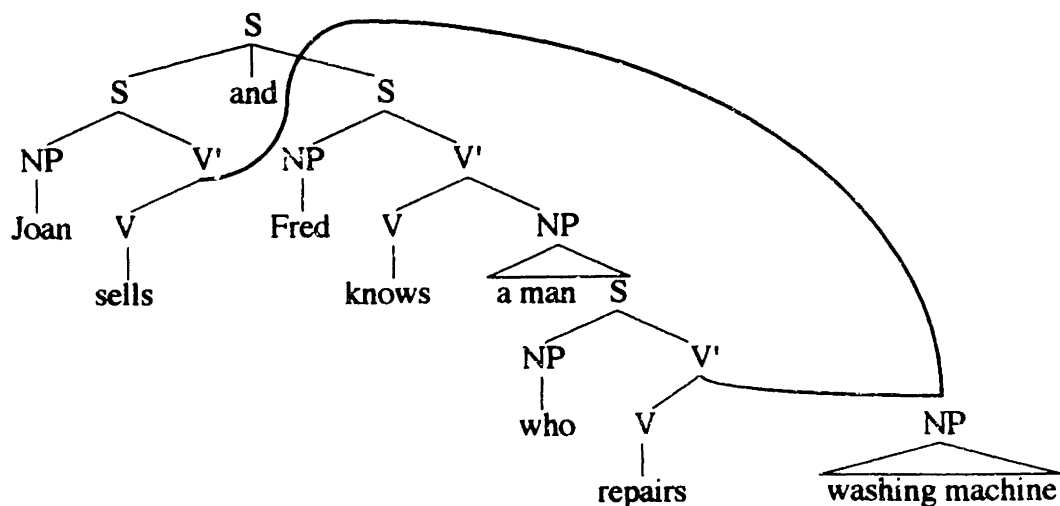

(McCawley 1987)

The Right-Node-Raised constituent, in this analysis, retains all the constituency relations that the identical constituents in the input had. More recent three-dimensional treatments of the RNR construction such as Moltmann's (1992) share basic insights and properties of this analysis.

Now turning back to the Japanese conjoined structures such as (11), if they are created by RNR and have a structure like (31) below in which the verb is part of the coordinate structure, it is predicted that, whenever the coordinate structure is scrambled or clefted, its verb is also scrambled or clefted along with it.

(31)

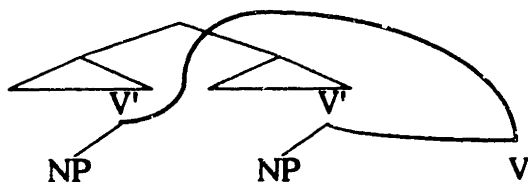

That this prediction fails has already been shown by the examples in (18) through (23), in which the conjoined structures are scrambled or clefted without the verb being affected by the same process. A relevant example is repeated as (32).

(32) [[John-ni ringo-o 2-tu] to [Bob-ni banana-o 3-bon]]_i
[[John-to apple-ACC 2-CL] and [Bob-to banana-ACC 3-CL]]_i

Mary-ga t_i ageta (sono zizitu)
Mary-NOM t_i gave (*the fact*)
 'Mary gave two apples to John and three bananas to Bob.'

Furthermore, the verb cannot be scrambled along with the (other parts of the) conjoined structures. Compare (32) with (33).

(33) * John-ni ringo-o 2-tu to Bob-ni banana-o 3-bon ageta
 John-to apple-ACC 2-CL and Bob-to banana-ACC 3-CL gave
 Mary-ga (sono zizitu)
 Mary-NOM (the fact)

If the conjoined structures had a representation like (31), it should be possible to derive (33) by preposing the conjoined structures across the subject.

Thus, we can conclude that the Japanese coordination sentences in question are not derived by Right-Node-Raising. Rather, they are derived by across-the-board verb raising in overt syntax, as I have argued.

3. Consequences

The proposed analysis that verbs in Japanese raise to C in overt syntax has a number of important consequences both for the general theory of Universal Grammar and for analyses of particular phenomena in Japanese. I will discuss six of them below.

3.1. Restructuring

It is known that the purpose clause of the type given in (34) may optionally undergo restructuring with certain matrix verbs (such as *iku* 'go' and *kuru* 'come'), rendering the underlyingly biclausal sentence into an effectively monoclausal structure (Miyagawa 1986).

(34) Hanako_i-ga (tosyokan-ni) [PRO_i zassi-o kari-ni] ik-u
 Hanako-NOM (library-to) [PRO_i magazine-ACC borrow-to] go-PRES
 'Hanako goes (to the library) to borrow magazines.'

As shown in (35), the negative polarity item *NP-sika* "anything but NP" ordinarily needs to be licensed by a clause-mate negation.¹⁰

- (35) a. Hanako-Top (tosyokan-de) **zassi-sika** kari-na-i
Hanako-TOP (library-at) magazine-SIKA borrow-not-PRES
 'Hanako does not borrow anything but magazines (at the library).'
 (Hanako borrows nothing but magazines (at the library).)
- b. * Taro-wa [Hanako-ga (tosyokan-de) **zassi-sika**
Taro-TOP [Hanako-NOM (library-at) magazine-SIKA
 kari-ru to] iwa-na-katta
borrow-PRES that] say-not-PAST
 Lit. 'Taro did not say that Hanako borrows anything but magazines (at the library).'

In the purpose clause construction, however, thanks to Restructuring, the negative polarity item *NP-sika* may be licensed in the object position of the purpose clause, by the matrix negation, as demonstrated in (36).

- (36) Hanako-wa (tosyokan-ni) [**zassi-sika** kari-ni] ik-ana-i
Hanako-TOP (library-to) [magazine-SIKA borrow-to] go-not-PRES
 'Hanako does not go (to the library) to borrow anything but magazines.'
 (Hanako goes (to the library) to borrow nothing but magazines.)

(37) shows that Restructuring is impossible if the purpose clause is not adjacent to the matrix verb:

- (37) * Hanako-wa [**zassi-sika** kari-ni] tosyokan-ni ik-ana-i
Hanako-TOP [magazine-SIKA borrow-to] library-to go-not-PRES
 'Hanako goes to the library to borrow nothing but magazines.'

¹⁰ At this moment, it is not clear to me how to derive the clause-mate condition on NPI licensing within the framework assumed in this thesis.

On the other hand, when the purpose clause is not adjacent to the matrix verb as in (39)b, the matrix subject cannot be in the same conjunct as the object of the subordinate clause. This shows that Restructuring has not taken place. The cleft examples in (41) point to the same conclusion.¹¹

- (41) a. (Tosyokan-ni) kari-ni itta no-wa [Hanako-ga zassi-o
(library-to) borrow-to went NL-TOP [Hanako-NOM magazines-ACC
 3-satu] da
 3-CL] be
 Lit. 'It is [Hanako three magazines] that went (to the library) to borrow.'
 (Hanako went to borrow three magazines.)
- b. * Kari-ni tosyokan-ni itta no-wa [Hanako-ga zassi-o
bor/row-to library-to went NL-TOP [Hanako-NOM magazines-ACC
 3-satu] da
 3-CL] be
 Lit. 'It is [Hanako three magazines] that went to the library to borrow.'
 (Hanako went to the library to borrow three magazines.)

I have shown that Restructuring with a purpose clause takes place in overt syntax. Other Restructuring constructions in Japanese also seem to undergo Restructuring before SPELL-OUT.

3.2. Complex Predicate Formation

As we have seen in Chapter 4, Japanese has complex verb constructions of the type shown in (42) through (44).

(42) Raising (Non-stative)

John-ga ringo-o tabe-kake-ta
 John-NOM apple-ACC eat-be.about.to-PAST
 'John was about to eat an apple.'

¹¹ If Restructuring is indeed an overt syntactic process, then the adjacency between the purpose clause and the matrix verb is a consequence of Restructuring; and it may or may not be a prerequisite of it.

- (43) Control (Non-stative)
 John-ga ringo-o tabe-wasure-ta
 John-NOM apple-ACC eat-forget-PAST
 'John forgot to eat an apple.'
- (44) Stative (Control)
 John-ga ringo-o/-ga tabe-rare-ru
 John-NOM apple-ACC/-NOM eat-can-PRES
 'John can eat an apple.'

These examples all have syntactic complementation, and the constituent verbs of a complex verb are underlyingly separate syntactic terminal nodes, as schematized in (45).

- (45) [... .[... object V] V]

The complex verb is formed by raising the lower verb to the higher verb under head to head movement. For the now familiar reasons, the following examples show that the embedded verbs, as well as the matrix verbs, raise to the position higher than the matrix subject before SPELL-OUT, which in turn implies that the complex verbs are formed in overt syntax.

- (46) Raising (Non-stative)
- a. John-ga ringo-o 2-tu to Mary-ga banana-o 3-bon
John-NOM apple-ACC 2-CL and Mary-NOM banana-ACC 3-CL
 tabe-kake-ta (koto)
eat-be.about.to-PAST
 Lit. '[John two apples] and [Mary three bananas] was about to eat.'
 (John was about to eat two apples, and Mary three bananas.)
- b. Tabe-kake-ta no-wa John-ga ringo-o 2-tu da
eat-be.about.to-PAST NL-TOP John-NOM apple-ACC 2-CL be
 Lit. 'It is [John two apples] that was about to eat.'
 (John was about to eat two apples.)
- (47) Control (Non-stative)
- a. John-ga ringo-o 2-tu to Mary-ga banana-o 3-bon
John-NOM apple-ACC 2-CL and Mary-NOM banana-ACC 3-CL
 tabe-wasure-ta (koto)
eat-forget-PAST

Lit.'[[John two apples] and [Mary three bananas]] forgot to eat.'
 (John forgot to eat two apples, and Mary three bananas.)

- b. Tabe-wasure-ta no-wa John-ga ringo-o 2-tu da
eat-forget-PAST NL-TOP John-NOM apple-ACC 2-CL be

Lit. 'It is [John two apples] that forgot to eat.'
 (John forgot to eat two apples.)

(48) Stative (Control)

- a. John-ga ringo-o/-ga 2-tu to Mary-ga banana-o/-ga
John-NOM apple-ACC/-NOM 2-CL and Mary-NOM banana-ACC/-NOM
 3-bon tabe-rare-ru (koto)
3-CL eat-can-PRES

Lit.'[[John two apples] and [Mary three bananas]] can eat.'
 (John can eat two apples, and Mary three bananas.)

- b. Tabe-rare-ru no-wa John-ga ringo-o/-ga 2-tu da
eat-can-PRES NL-TOP John-NOM apple-ACC/-NOM 2-CL be

Lit. 'It is [John two apples] that can eat.'
 (John can eat two apples.)

The causative constructions also undergo complex verb formation before the derivation branches off to PF:

(49) Causative

- a. John-ga Becky-ni ringo-o 2-tu to Mary-ga Bryn-ni
John-NOM Becky-DAT apple-ACC 2-CL and Mary-NOM Bryn-DAT
 banana-o 3-bon tabe-sase-ta (koto)
banana-ACC 3-CL eat-CAUS-PAST (fact)

Lit.'[[John Becky two apples] and [Mary Bryn three bananas]] made eat.'
 (John made Becky eat two apples, and Mary made Bryn eat three bananas.)

- b. Tabe-sase-ta no-wa John-ga Becky-ni ringo-o 2-tu da
eat-CAUS-PAST NL-TOP John-NOM Becky-DAT apple-ACC 2-CL be

Lit. 'It is [John Becky two apples] that made eat.'
 (John made Becky eat two apples.)

The above discussion constitutes a counterargument to certain analyses of complex predicate constructions. For example, Takezawa (1987) suggests that the potential

construction of the type exemplified in (48) schematically has a structure like (50)a after Reanalysis. Infl then lowers to the complex verb at S-structure in order to assign Nominative Case to the nominative object, as shown in (50)b.

(50) Takezawa's (1987) analysis of the potential construction

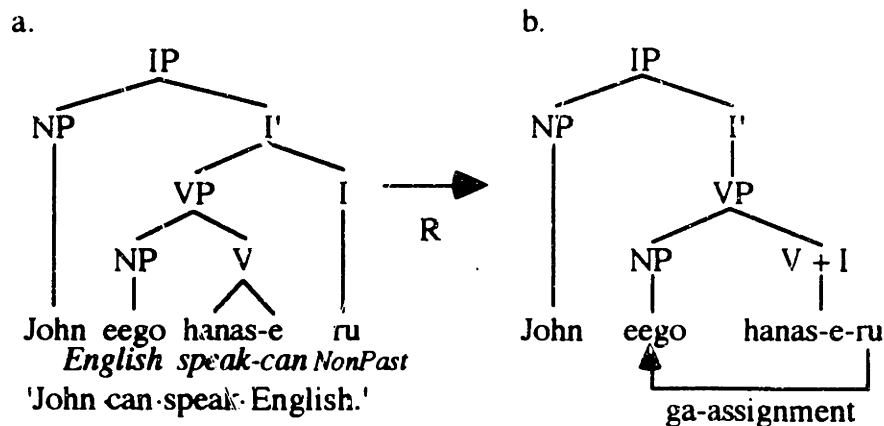

Under this analysis, the complex verb is lower than the subject at the point of SPELL-OUT. If this were the case, the subject and the object should not be able to occur in the same conjunct or in the same focused constituent that excludes the complex verb, contrary to the facts shown in (48).

A similar remark applies to so-called excorporation analyses in which a complex verb is introduced to syntax as a single unit as in (51)a, and is later "decomposed" by excorporation head movement of its constituent (or Affix Raising) as in (51)b.

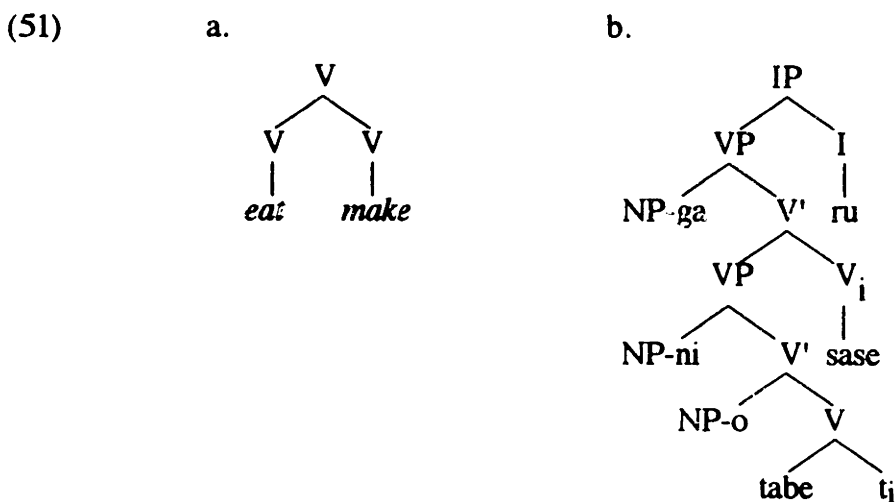

Whether the excorporation takes place between D-structure and S-structure, or between S-structure and LF, the embedded verb remains lower than the matrix subject throughout the derivation. Thus, in this type of analyses, there is no constituent that dominates the matrix subject and the embedded object but not the (combined) verbs. This is in direct conflict with the coordination and cleft facts we have seen above.

In sum, we have shown that complex verbs in Japanese are formed by V-Raising in overt syntax, hence lowering analyses and excorporation analyses of the complex verb constructions cannot be maintained.

3.3. Proper Binding Condition

It has been an issue whether the Proper Binding Condition given in (52) holds at S-structure (cf. Harada 1972; Fiengo 1977; May 1977; Saito 1985; 1989; 1992; Lasnik and Saito 1992; Besten and Webelhuth 1990; Müller 1993; 1994; Collins 1994; Takano 1994; Kitahara 1994, among others).

(52) Proper Binding Condition: Trace must be bound.

(cf. Fiengo 1977; May 1977)

I will argue that, if the proposed overt V-Raising analysis is correct, the PBC does not apply in overt syntax. It is also suggested that the PBC as a specific condition should be eliminated from syntax altogether.

Consider (53)c, which is derived from (53)a by two applications of scrambling. The embedded object is first scrambled to the sentence initial position as shown in (53)b, then the embedded clause containing the trace of the fronted object is preposed across that object.

- (53) a. John-ga [Bill-ga sono mura-ni sundeiru to] omotteiru
John-NOM [Bill-NOM that village-in reside COMP] think
 'John thinks that Bill lives in that village.'
- b. Sono murø-nij John-ga [Bill-ga t_j sundeiru to] omotteiru
that village-in John-NOM [Bill-NOM t_j reside COMP] think
 ↑ _____ (I) _____ ↓

- c. * [Bill-ga t_i sundeiru to]j sono mura-ni John-ga t_j omotteiru
[Bill-NOM t_i reside COMP]j that village-ini John-NOM t_j think
 ↑ _____ (II) _____ ↓

(cf. Saito 1985; 1989)

Saito (1989) argues that, if the PBC applies at S-structure (as well as LF), (53)c is correctly ruled out by this condition, as the preposed clause contains an unbound trace t_i . On the other hand, if the PBC holds only at LF, the ungrammaticality of (53)c remains unexplained. It might appear that (53)c violates the PBC at LF. However, given the common assumption that (long-distance) scrambling can be freely undone in LF (cf. Saito 1985), one possible LF representation of (53)c should be basically the same as that of the grammatical (53)a. Thus, the ungrammaticality of (53)c cannot be attributed to a violation of the PBC at LF, hence it is regarded as one of the central cases motivating S-structure application of the PBC.¹²

Several proposals have been made to eliminate S-structure application of the PBC (cf. Müller 1993; 1994; Takano 1994; Kitahara 1994, to name just a few). Most such proposals are designed, in part, to derive Müller's (1993; 1994) generalization given in (54).

- (54) A reinterpretation of Müller's generalization as a derivational constraint:
 α cannot undergo X-movement resulting in the structure in which α dominates an unbound trace of β , if β has been created by X-movement.

(adapted from Müller 1993; 1994)

Kitahara (1994), for example, proposes a general economy condition on derivation, called *Restrict*, from which (54) is derived.¹³ He argues that, given *Restrict*, the

¹² Collins (1994) argues that all known cases of the PBC violations involve either downward movement or chain interleaving, and that, since both downward movement and chain interleaving are ruled out by a version of the principle of Economy of Derivation, the PBC is redundant. Unfortunately, Collins' ingenious proposal cannot accommodate the examples in (53)c and (64)c, which involve neither downward movement nor chain interleaving.

¹³ Kitahara's (1994) *Restrict* is shown below.

(→continue)

ungrammaticality of (53)c can be accounted for, without recourse to S-structure application of the PBC, in the following manner. The movement (I) in (53) is a long-distance, A-bar, scrambling.¹⁴ The movement (II) is a middle-distance scrambling, which can be either A or A-bar movement. Then, there are two possible derivations of (53)c, as shown in (55).

(i) *Restrict*

Move raises a category α to a position β only if α is the closest category to β among all the categories bearing morphological feature(s) of a category γ , where the domain of γ is the smallest domain containing β .

The Japanese example (53)c and the English example (iia) violate Restrict twice, whereas (iib) violates it only once. The deviancy is milder in (iib) for this reason.

- (ii) a. * [Which picture of t_{ij}] do you wonder who_i Mary bought t_{ij} ?
 b. ?? Who_i do you wonder [which picture of t_{ij}] Mary bought t_{ij} ?

It is not crucial for our text discussion whether or not this particular way of deriving Müller's generalization is correct. Müller's generalization can also be derived from a proper formalization of Chomsky's (Class lectures, Fall 1994) suggestion that movement is induced when a functional head attracts a certain feature, thus traditional Move- α should be replaced by Attract-F.

(iii) *Attract-F: Attract the closest F.*

Cf. also Oka (1993a; 1993b) and Takahashi (1994) for discussions of "shortest move" phenomena in general.

¹⁴ Scrambling in Japanese can be divided into three types with respect to its "distance" or "length": S(hort-distance)-scrambling, M(iddle-distance)-scrambling, L(ong-distance) scrambling (Tada 1993; cf. also Mahajan 1990).

- (i) a. S-scrambling: S DO_i IO t_{ij} V
 b. M-scrambling: XP_i S ... t_{ij} ... V
 c. L-scrambling: XP_i ... [... t_{ij} ... V] ("..." indicates a tensed clause boundary)

It is widely assumed among Japanese linguists that S-scrambling is purely A-movement, and L-scrambling is purely A-bar movement. M-scrambling is considered to be ambiguous between A and A-bar movement (cf. Tada 1993; Miyagawa 1991; Saito 1992; but see Yoshimura 1992).

(55) The two possible derivations of (53)c:

	(I)	(II)	
Derivation I	A- \bar{t} ar	A	* PBC violation at LF
Derivation II	A- \bar{b} ar	A-bar	* violation of (54)

If the movement (II) is A-scrambling, (53)c is ruled out by the PBC at LF, because A-scrambling cannot be undone or "reconstructed". On the other hand, if the movement (II) is A-bar scrambling, (53)c violates Müller's generalization in (54) (hence Kitahara's Restrict) because the A-bar scrambled clause contains a trace created by the same type of movement, i.e. the A-bar scrambling (I).

Given Kitahara's (1994) account of (53)c, it is predicted that the structure created by the derivation in (56) is grammatical.

- (56) a. ... X ... [... Y ...] ...
 b. Y_i ... X. [... t_i ...] ...
 ↑ _____ | A-scrambling
 c. [... t_i ...] $_j$... Y_i ... X ... t_j ...
 ↑ _____ | A-bar scrambling

This is so because (56)c does not violate Müller's generalization, nor does it violate the PBC at LF, as the A-bar scrambling can be undone in LF. This prediction seems to be borne out. Consider (57).

- (57) a. (?) [[Tom-ga Mary-ni ringo-o 2-tu] to [Bob-ga Mary-ni
 [[Tom-NOM Mary-to apple-ACC 2-CL] and [Bob-NOM Mary-to
 banana-o 3-bon]] ageta (koto)
 banana-ACC 3-CL]] gave (fact)
 Lit. '[Tom two apples to Mary] and [Bob three bananas to Mary] gave.'
 (Tom gave two apples to Mary and Bob gave three bananas to Mary.)
 b. Mary- $_{iij}$ [[Tom-ga t_i ringo-o 2-tu] to [Bob-ga t_i
 Mary- $_{toj}$ [[Tom-NOM t_j apple-ACC 2-CL] and [Bob-NOM t_j
 ↑ _____ | "across-the-board" scrambling _____ | (I)
 banana-o 3-bon $_j$] ageta (koto)
 banana-ACC 3-CL]] gave (fact)

- c. [[Tom-ga t_i ringo-o 2-tu] to [Bob-ga t_j
[[Tom-NOM t_i apple-ACC 2-CL] and [Bob-NOM t_j
banana-o 3-bon]]j Mary-ni t_j ageta (koto)
banana-ACC 3-CL]]j Mary-to_i t_j gave (fact)
 ↑ _____ ↓ (II)

The example (57)c is derived from (57)a, by first scrambling the Goal object to the sentence initial position in the "across-the-board" manner as in (57)b, and then fronting the coordinate structure across the preposed Goal object. The two movements are both middle-distance scrambling, hence they can be either A or A-bar movement. There are thus four possible combinations, as shown in (58).

(58)	(I)	(II)	
Case I	A-bar	A-bar	* violation of (54)
Case II	A	A	* violation of (54)
Case III	A-bar	A	* PBC violation in LF
Case IV	A	A-bar	✓

Case I and Case II are ruled out by Müller's generalization (or whatever derives it, such as Kitahara's Restrict). Case III and Case IV do not violate Müller's generalization. In Case III, the coordinate structure is A-scrambled, which cannot be undone or "reconstructed." Therefore, it contains an unbound trace, t_j, at LF, in violation of the PBC. The remaining possibility is Case IV. The grammaticality of (57)c suggests that Case IV is allowed by grammar. In fact, it not only obeys Müller's generalization, but also satisfies the PBC at LF, as the A-bar scrambling of the coordinate structure can be undone in LF. Note that, if the PBC were to apply at S-structure, (57)c should be ruled out. Thus, the grammaticality of (57)c strongly suggests that the PBC as an S-structure requirement does not exist. The following examples point to the same conclusion.

- (59) a. (?) [[Tom-ga Mary-ni ringo-o 2-tu] to [Bob-ga Nancy-ni
 [[Tom-NOM Mary-to apple-ACC 2-CL] and [Bob-NOM Nancy-to
 ringo-o 3-tu]] ageta (koto)
 apple-ACC 3-CL]] gave (fact)
 Lit. '[Tom two apples to Mary] and [Bob three bananas to Mary] gave.'
 (Tom gave two apples to Mary and Bob gave three bananas to Mary.)

- b. Ringo-o_i [[Tom-ga Mary-ni t_i 2-tu] to [Bob-ga Nancy-ni t_i Apple-ACC_i; [Tom-NOM Mary-to t_i 2-CL] and [Bob-NOM Nancy-to t_i (I) ↑ _____ | "across-the-board" scrambling _____ |

3-tu]] ageta (koto)

3-CL]] gave

- c. [[Tom-ga Mary-ni t_i 2-tu] to [Bob-ga Nancy-ni t_i 3-tu]];
[[Tom-NOM Mary-DAT t_i 2-CL] and [Bob-NOM Nancy-DAT t_i 3-CL]];
ringo-o_i t_j ageta (koto)
apple-ACC_i t_j gave

(II) ↑ _____ |

- (60) a. (?) Tom-ga [[Mary-ni ringo-o 2-tu] to [Nancy-ni Tom-NOM [[Mary-to apple-ACC 2-CL] and [Nancy-to ringo-o 3-tu]] ageta (koto)
apple-ACC 3-CL]] gave

'Tom gave two apples to Mary and three apples to Nancy.'

- b. Tom-ga ringo-o_i [[Mary-ni t_i 2-tu] to [Nancy-ni t_i Tom-NOM apple-ACC_i; [[Mary-to t_i 2-CL] and [Nancy-to t_i (I) ↑ "across-the-board" | scrambling _____ |

3-tu]] ageta (koto)

3-CL]] gave

- c. [[Mary-ni t_i 2-tu] to [Nancy-ni t_i 3-tu]] Tom-ga ringo-o_i t_j [[Mary-to t_i 2-CL] and [Nancy-to t_i 3-CL]] Tom-NOM apple-ACC_i t_j (II) ↑ _____ |

agetā (koto)

gave

The example (61)c may be derived from (61)a by two applications of scrambling shown in (61).

- (61) a. ? John-ga [[[Tom-ga Mary-ni ringo-o 2-tu] to [Bob-ga John-NOM [[[Tom-NOM Mary-to apple-ACC 2-CL] and [Bob-NOM Mary-ni banana-o 3-bon]]] ageta to] omotteiru (koto)
Mary-to banana ACC 3-CL]] gave that] believe (fact)
Lit. 'John believes [that [Tom two apples to Mary] and [Bob three bananas to Mary] gave.'

(John believes that Tom gave two apples to Mary and Bob gave three bananas to Mary.)

- b. ? Mary-ni John-ga [[[Tom-ga t_i ringo-o 2-tu] to [Bob-ga t_j Mary-to John-NOM [[[Tom-NOM t_i apple-ACC 2-CL] and [Bob-NOM t_j (I) ↑ _____ | "across-the-board" A-bar scrambling | banana-o 3-bon]] ageta to] omotteiru (koto)
banana-ACC 3-CL]] gave that] believe (fact)
- c. ? [[Tom-ga t_i ringo-o 2-tu] to [Bob-ga t_j banana-o
 [[Tom-NOM t_i apple-ACC 2-CL] and [Bob-NOM t_j banana-ACC
 3-bon]]] Mary-ni John-ga [t_j ageta to] omotteiru (koto)
 3-CL]]] Mary-to John-NOM [t_j gave that] believe (fact)
 ↑ _____ A-bar scrambling _____ | (II)

This derivation, like the ungrammatical (53), contains A-bar scramblings, in violation of Müller's generalization. Thus, the example (61)c should be as unacceptable as (53)c, yet it is only mildly awkward (probably due to parsing difficulties). The sentence is grammatical because it has alternative derivations that obey Müller's generalization (54). This is shown below.

- (62) a. ? John-ga [[[Tom-ga Mary-ni ringo-o 2-tu] to [Bob-ga
 John-NOM [[[Tom-NOM Mary-to apple-ACC 2-CL] and [Bob-NOM
 Mary-ni banana-o 3-bon]] ageta to] omotteiru (koto)
 Mary-to banana-ACC 3-CL]] gave that] believe (fact)
 Lit. 'John believes [that [Tom two apples to Mary] and [Bob three bananas
 to Mary] gave.'
 (John believes that Tom gave two apples to Mary and Bob gave three
 bananas to Mary.)
- b. John-ga [Mary-ni] [[Tom-ga t_i ringo-o 2-tu] to [Bob-ga t_j
 John-NOM [Mary-to] [[Tom-NOM t_i apple-ACC 2-CL] and [Bob-NOM t_j
 (I) ↑ _____ | "across-the-board" A-scrambling _____ |
 banana-o 3-bon]] ageta to] omotteiru (koto)
 banana-ACC 3-CL]] gave that] believe (fact)

- c. (?) Mary-ni John-ga [t_i' [[Tom-ga t_i ringo-o 2-tu] to
Mary-to John-NOM [t_i' [[Tom-NOM t_i apple-ACC 2-CL] and
 (II) ↑ A-bar scrambling |¹⁵
 [Bob-ga t_i banana-o 3-bon]] ageta to] omotteiru (koto)
 [Bob-NOM t_i banana-ACC 3-CL]] gave that believe (fact)
- d. ? [[Tom-ga t_i ringo-o 2-tu] to [Bob-ga t_i banana-o
[[Tom-NOM t_i apple-ACC 2-CL] and [Bob-NOM t_i banana-ACC
 3-bon]]] Mary-ni John-ga [t_i' t_j ageta to] omotteiru (koto)
3-CL]] Mary-to John-NOM [t_i' t_j gave that] believe (fact)
 ↑ A-bar scrambling | (III)
- (63) a. ? John-ga [[[Tom-ga Mary-ni ringo-o 2-tu] to [Bob-ga
 John-NOM [[[Tom-NOM Mary-to apple-ACC 2-CL] and [Bob-NOM
 Mary-ni banana-o 3-bon]]] ageta to] omotteiru (koto)
 Mary-to banana-ACC 3-CL]] gave that believe (fact)
 Lit. 'John believes [that [Tom two apples to Mary] and [Bob three bananas
 to Mary] gave.'
 (John believes that Tom gave two apples to Mary and Bob gave three
 bananas to Mary.)
- b. (?) [[Tom-ga Mary-ni ringo-o 2-tu] to [Bob-ga Mary-ni
[[Tom-NOM Mary-to apple-ACC 2-CL] and [Bob-NOM Mary-to
 banana-o 3-bon]]] John-ga [t_j ageta to] omotteiru (koto)
banana-ACC 3-CL]] John-NOM [t_j gave that] believe (fact)
 ↑ A scrambling | (I)
- c. ? Mary-ni [[Tom-ga t_i ringo-o 2-tu] to [Bob-ga t_i
Mary-to [[Tom-NOM t_i apple-ACC 2-CL] and [Bob-NOM t_i
 (II) ↑ _____ | "across-the-board" A-scrambling |
 banana-o 3-bon]]] John-ga [t_j ageta to] omotteiru (koto)
 banana-ACC 3-CL]] John-NOM [t_j gave that] believe (fact)
- d. ? [[Tom-ga t_i ringo-o 2-tu] to [Bob-ga t_i banana-o
[[Tom-NOM t_i apple-ACC 2-CL] and [Bob-NOM t_i banana-ACC

¹⁵ That a constituent that has undergone A-scrambling may subsequently undergo A-bar scrambling is shown in Tada (1993) (cf. also Mahajan 1995; and Saito 1992). See Abe (1993) for a different view.

3-bon]_j Mary-ni_i t_j' John-ga [t_j ageta to] omotteiru (koto)
3-CL]_j Mary-to_i t_j' John-NOM [t_j gave that] believe (fact)
 ↑ A-bar scrambling (III)

In these derivations, A-traces (t_j) are created in the coordinate structure, which subsequently undergoes A-bar scrambling. These derivations conform to Müller's generalization (54), hence the resultant structure is grammatical.¹⁶

To summarize so far, I have shown that the PBC does not apply in overt syntax. This is a desirable result from the perspective of the minimalist program, in which S-structure does not have independent status as in the GB theory. The question arises as to whether the PBC applies at LF. We have seen that, to account for the ungrammaticality of (53)c, we need to rule out the two derivations listed in (55). Derivation II is excluded by Müller's (1993; 1994) generalization. In Derivation I, there is an unbound A-bar trace at LF, which we ruled out by appealing to the PBC. Thus, we seem to have evidence that A-bar traces must be bound at LF. The following examples demonstrate the same point.¹⁷

- (64) a. John-wa [Bill-ga sono ie-o katta koto]-o sir-anai
John-TOP [Bill-NOM that house-ACC bought fact]-ACC know-not
 'John doesn't know that Bill bought that house.'
- b. ? Sono ie-o_i John-wa [Bill-ga t_j katta koto]-o sir-anai
that house-ACC_i John-TOP [Bill-NOM t_j bought fact]-ACC know-not
 ↑ _____ (I) _____ ↓
- c. * [Bill-ga t_j katta koto]-o_j sono ie-o_i John-wa t_j sir-anai
[Bill-NOM t_j bought fact]-ACC_j that house-ACC_i John-TOP t_j know-not
 ↑ _____ (II) _____ ↓

What we do *not* have is evidence showing that traces left behind by A-movement and head-movement are subject to the PBC at LF. In view of the examples of the following sort, in

¹⁶ (63), like (iib) in Note 12, violates Kitahara's Restrict once (the step in (63)c). Thus, if Restrict is correct, (62) is the only derivation that is fully grammatical of the example in question.

¹⁷ The mild unnaturalness of (64)b may be due to a weak violation of Subjacency. The contrast between (64)b and (64)c is still robust.

which traces of A-moved or head-moved elements appear to be unbound, it seems likely that they are immune to the PBC (but see Huang 1993; and Takano 1995).

- (65) a. Mary-ga ageta_v no-wa [John-ni ringo-o 3-tu t_v] da (= (1)b)
Mary-NOM gave_v NL-TOP [John-to apple-ACC 3-CL t_v] be
 Lit. 'It is [three apples to John] that Mary gave.'
 b. [How (t_i) likely (t_i) to t_i win] is John_i?
 c. What John_i is [is (t_i) likely (t_i) to t_i win]

The PBC then is reduced to the requirement that A-bar traces (variables) must be bound at LF. Since it is a special case of the more general requirement that variables must be bound at LF (which for example rules out a pronoun interpreted as bound variable but not c-commanded by its antecedent at LF), the residue of the PBC need not be stipulated as such in the grammar. If so, we have succeeded in eliminating the PBC from grammar as a specific syntactic condition.

3.4. Multiple Long-distance Scrambling as Remnant Scrambling

In most analyses of Subjacency including Chomsky's (1986b) and Lasnik & Saito's (1992), multiple long-distance movement necessarily violates Subjacency. Thus, it is expected that if more than one constituent is scrambled from within a tensed clause, the sentence will be degraded. This prediction seems to be borne out, as shown in (66).

- (66) a. No Scrambling
 John-ga [Kiyomi-ga Hawai-de Masami-ni purezento-o
John-NOM [Kiyomi-NOM Hawaii-at Masami-DAT present-ACC
 katta to] omotteiru (koto)
bought that] believe (fact)
 'John believes [that Kiyomi bought a present for Masami in Hawaii].'
 b. One L-Scrambling
 (?) Hawai-de₁ John-ga [Kiyomi-ga t₁ Masami-ni purezento-o
Hawai-de₁ John-NOM [Kiyomi-NOM t₁ Masami-DAT present-ACC
 katta to] omotteiru
bought that] believe

c. Two L-Scramblings

?? Masami-ni₂ Hawai-de₁ John-ga [Kiyomi-ga t₁ t₂ purezento-o
Masami-DAT₂ Hawai-de₁ John-NOM [Kiyomi-NOM t₁ t₂ present-ACC
 katta to] omotteiru
bought that] believe

d. Three L-Scramblings

??? Purezento-o₃ Masami-ni₂ Hawai-de₁ John-ga [Kiyomi-ga t₁ t₂
present-ACC₃ Masami-DAT₂ Hawai-de₁ John-NOM [Kiyomi-NOM t₁ t₂
 t₃ katta to] omotteiru
t₃ bought that] believe

(Koizumi 1991)

However, the acceptability of multiple L-scrambling sentences will improve significantly if the conditions in (67) are met.¹⁸

- (67) a. The L-scrambled elements form an intonation phrase.
 b. The L-scrambled elements observe "basic" word order.

(Koizumi 1991)

Thus, the examples in (68) and (69) are acceptable for many speakers, with appropriate intonation.

(68) |Hawai-de Masami-ni purezento-ol John-ga [Kiyomi-ga katta to]
 |Hawaii-at Masami-DAT present-ACC| John-NOM [Kiyomi-NOM bought that]
 omotteiru (koto)
believe

(same as (66))

(Koizumi 1991)

(69) |Bill-ni sono hon-ol Mary-ga [John-ga watasita to] omotteiru (koto)
 |Bill-to that book-ACC| Mary-NOM [John-NOM handed that] think (fact)

¹⁸ While (67)a seems to be a necessary condition for apparent multiple L-scrambling, (67)b is a weaker, violable condition.

Lit. [To Bill that book] Mary thinks that John handed.

(Mary thinks that John handed that book to Bill.)

(adapted from Saito 1985: 183)

To account for the acceptability of these sentences, I have suggested elsewhere (Kozumi 1991) that they involve a scrambling of the embedded VP (or some larger phrase), as shown in (70).

(70) Scrambling of a remnant VP

[VP Hawaii-de Masami-ni present-o t_y]_i J-ga [K-ga t_i katta_v to] omotteiru
[VP Hawaii-at Masami-DAT present-ACC t_y]_i J-NOM [K-NOM t_i bought_v that] believe
 ↑ _____ ↓

At that time, two objections were raised against this analysis (by personal communication). First, if it is the VP (or some larger phrase) that is fronted, it must contain a trace of the verb, and also a trace of the subject under some version of the Internal Subject Hypothesis. Then, as they are not bound at S-structure, why do they not induce a violation of the PBC? The second objection was that there was no known independent evidence that the verb overtly raises out of the VP in Japanese. The first objection presupposes S-structure application of the PBC (note that long-distance scrambling can be undone in LF). As we have just seen, there is now good reason to believe that the PBC does not apply at S-structure (or it does not exist at all). As for the second objection, I have shown, in the first section of this chapter, that verbs in Japanese do raise out of the VP in overt syntax. Thus, the two major obstacles to the remnant scrambling analysis of the examples like (68) and (69) have been removed. In fact, only remnant scrambling can account for the example like (71).

(71) [[John-ni ringo-o 2-tu] to [Bob-ni banana-o 3-bon]]_i (= (22))

[[John-to apple-ACC 2-CL] and [Bob-to banana-ACC 3-CL]]_i

Nancy-ga [Mary-ga t_i ageta to] omotteiru (koto)

Nancy-NOM [Mary-NOM t_i gave that] believe

Lit. '[two apples to John and three bananas to Bob]_i Nancy believes that Mary gave t_i.'

(Nancy believes that Mary gave two apples to John and three bananas to Bob.)

In conclusion, Japanese does have remnant scrambling, as I suggested in my earlier work (Koizumi 1991).

3.5. Are Floating Quantifiers Floating?

There are two hypotheses concerning the constituency of the string "NP-Case NQ" exemplified below.

- (72) a. **Gakusee-ga 2-ri** kita.
students-NOM 2-CL came
'Two students came.'
- b. **Becky-ga ringo-o 3-tu** katta.
Becky-NOM apple-ACC 3-CL bought
'Becky bought three apples.'

Under the "base-generation" hypothesis, on the one hand, NP-Case and NQ are base-generated as separate constituents; under the "single constituency" hypothesis, on the other, they form a single constituent "at base" (see Kamio 1977; Ueda 1986; Miyagawa 1989; Terada 1990; Kitahara 1992; Fujita 1994; Miyamoto 1994, and the references cited there). Thus, Miyagawa (1989) suggests that both the NQ in (72)b and its host NP are directly dominated by VP, as shown in (73)a; whereas Kitahara (1992) maintains that they comprise an object DP, as in (73)b.

- (73) a. [VP [NP-Case] [NQ] V]
b. [VP [DP NP-Case NQ] V]

Both Miyagawa (1989) and Kitahara (1992) assume that, when NQ and its host NP are separated as in (74), the NP has moved from its original position.

- (74) **Ringo-oi** Becky-ga *t_i* **3-tu** katta.
apple-ACC_i Becky-NOM t_i 3-CL bought
'Becky bought three apples.'

The central evidence for the single constituency analysis has to do with coordination and clefting. Kamio (1977) observed that "NP-Case NQ" can be coordinated or clefted, as shown below.

- (75) a. [[Gakusee-ga 2-ri] to [sensee-ga 3-nin]] kita
 [[students-NOM 2-CL] and [teacher-NOM 3-CL]] came
 'Two students and three teachers came.'
- b. Becky-ga [[ringo-o 3-tu] to [banana-o 7-hon]]
 Becky-NOM [[apple-ACC 3-CL] and [banana-ACC 7-CL]]
 katta. (koto)
 bought
 'Becky bought three apples and seven bananas.'
- (76) a. Kita no-wa [Gakusee-ga 2-ri] da
 came NL-TOP [students-NOM 2-CL] be
 'It is two students that came.'
- b. Becky-ga katta no-wa [ringo-o 3-tu] da
 Becky-NOM bought NL-TOP [apple-ACC 3-CL] be
 'It is three apples that Becky bought.'

These two constituency tests suggest that NQ and its host NP form a constituent. From this, Kamio (1977) concluded that the base-generation hypothesis must be rejected in favor of the single constituency hypothesis.

This was a fair conclusion in the late seventies, when Japanese clause structure was assumed, by many researchers, to be "flat", and the possibility of overt V to C movement was not even dreamt of. However, now that we know verbs in Japanese overtly raise to a position higher than the subject, Kamio's conclusion is not warranted anymore. For example, (75)b may be a VP coordination, as shown in (77), with which the base-generation analysis is compatible.

- (77) Becky-ga [VP [VP ringo-o 3-tu t_v] to [VP banana-o 7-hon t_v]]
 Becky-NOM [VP [VP apple-ACC 3-CL t_v] and [VP banana-ACC 7-CL t_v]]
 kattav
 bought_v
 'Becky bought three apples and seven bananas.'

Similarly, the focused constituent in (76)a can be a remnant IP:

- (78) Kita no-wa [IP Gakusee-ga 2-ri tv] da
came NL-TOP [IP students-NOM 2-CL tv] be
 'It is two students that came.'

Thus, while the NP coordination and NP cleft analyses are possibilities, they are not the only analyses compatible with the data in (75) and (76). Specifically, the conjuncts and the focus constituent in question may be a remnant VP or IP. Thus, to the extent that this is correct, the base-generation hypothesis of the floating quantifier construction can be maintained, and the single constituency hypothesis has lost its strongest (and only) pieces of evidence.

As a support of the remnant coordination and clefting analysis, consider the following sentences.¹⁹

- (79) a. [[Gakusee-ga kinoo 2-ri] to [sensee-ga kyoo 3-nin]]
[[students-NOM yesterday 2-CL] and [teacher-NOM today 3-CL]]
 kita. (koto)
came
 'Two students came yesterday, and three teachers came today.'
- b. John-ga katta no-wa [ringo-o kinoo 3-tu] da
John-NOM bought NL-TOP [apple-ACC yesterday 3-CL] be

The focus constituent in (79)b contains an adverb "yesterday", which modifies the event of buying rather than the object NP "apples". Since event modifiers such as time adverbials do not normally occur within non-event denoting nominal phrases, the grammaticality of the sentence suggests that the focus constituent is not an NP (or DP or QP or whatever), rather it is an event denoting category such as VP. For the same reason, the conjuncts in (79)a, containing a time adverb, cannot be NPs. They are most likely IPs (or AGRsPs). The following sentences with secondary predicates point to the same conclusion.²⁰

¹⁹ I owe (79)a to Toshifusa Oka (personal communication).

²⁰ The bold faced elements in (80) are secondary predicates. They are not NP-internal modifiers. For the syntactic distribution of secondary predicates in Japanese, see Koizumi (1994b).

- (80) a [[Gakusee-ga **hadakade** 2-ri] to [sensee-ga **hadaside**
 [[*students-NOM naked* 2-CL] and [*teacher-NOM barefooted*
 3-nin]] hasitta (koto)
 3-CL]] *run*
 'Two students run naked, and three teachers run barefoot.'
- b. John-ga tabeta no-wa [katuo-o **namade** 2-kire] da
John-NOM ate NL-TOP [bonito-ACC raw 2-CL] be
 Lit. 'It is two pieces of bonito raw that John ate.'
 (John ate two pieces of bonito raw.)

Cases like (81) may be derived by two applications of scrambling in addition to head movements. This is schematically shown in (82).

- (81) [[*tyuugokuzin-ga* 2-ri] to [*nihonzin-ga* 3-nin]] ronbun-o happyoosita.
 [[*Chinese-NOM* 2-CL] and [*Japanese-NOM* 3-CL]] *paper-ACC presented*
 'Two Chinese and three Japanese presented their papers.'
- (82) a. [[*Chinese* two papers t_V] and [*Japanese* three papers t_V]] presented_V
 "across-the-board" | overt V-Raising | _____ ↑
- b. papers_i [[*Chinese* two t_i t_V] and [*Japanese* three t_i t_V]] presented_V
 ↑ "across-the-board" | scrambling | _____
- c. [[*Chinese* two t_i t_V] and [*Japanese* three t_i t_V]] papers_i t_j presented_V
 ↑ scrambling | _____

Since, under this analysis, both conjuncts in (82)c contain a trace of the scrambled object, it is expected that NQs associated with the traces may occur in the conjuncts. This prediction is in fact borne out.²¹

²¹ The slight unnaturalness of (83) is due to the fact that both the subject and the object are associated with numeral quantifiers, which usually causes minor awkwardness. If the NQs associated with the subjects are removed, the sentence becomes quite natural:

- (i) [[*tyuugokuzin-ga* 4-hon] to [*nihonzin-ga* 6-pon]] ronbun-o
 [[*Chinese-NOM* 4-CL] and [*Japanese-NOM* 6-CL]] *paper-ACC*
 happyoosita. (koto)
presented
 Lit. 'Chinese four and Japanese six presented papers.'
 'Chinese presented four papers, and Japanese presented six papers.'

(→continue)

(83) ? [[tyuugokuzin-ga 2-ri 4-hon] to [nihonzin-ga 3-nin 6-pon]] ronbun-o
 [[Chinese-NOM 2-CL 4-CL] and [Japanese-NOM 3-CL 6-CL]] paper-ACC
 happyoosita. (koto)
presented

Lit. 'Chinese two four and Japanese three six presented papers.'

'Two Chinese presented four papers, and three Japanese presented six papers.'

Again, this is totally unexpected if what is coordinated or clefted is an NP as in Kamio's (1977) analysis.

To summarize, the two central cases motivating the single constituency hypothesis of the NQ construction turned out to be non-evidence. They can be readily explained under the base-generation hypothesis if Japanese is an overt V-Raising language as I have argued. Note, however, that I am *not* arguing *against* the single constituency hypothesis. All I did, in this subsection is to show that if there is evidence for the single constituency hypothesis, we have not seen it.

3.6. Is Japanese SVO?

Kayne (1994) suggests that all human languages are SVO in their underlying structures. This is in direct conflict with the standard assumption that Japanese is a head final language in the most strict sense, which I have been assuming throughout the entire thesis. Kayne's proposal is attractive and important because, if it turns out to be correct, the range of possible syntactic representations will be significantly narrowed, which in turn contributes to attaining a highly restrictive theory of syntax. For this reason, I will consider, in this final part of the thesis, whether or not the empirical results we have obtained of Japanese can be made compatible with his proposal.

Central to Kayne's (1994) proposal is the Linear Correspondence Axiom (LCA), according to which the linear ordering of the terminal nodes of a given phrase marker is a direct reflex of asymmetric c-command relations among the non-terminal nodes in that phrase marker:

If an example like (81) shows, as claimed in Kamio (1977), that the NQ associated with the subject is a part of the subject NP (or CP), the sentence in (i) should "show" that the NQ associated with the object is a part of the subject constituent, a conclusion no one would accept.

- (84) Linear Correspondence Axiom:
 $d(A)$ is a linear ordering of T .
 (Kayne 1994)

For a given phrase maker P , T is the set of terminals. A is the maximal set of ordered pairs of nonterminals $\langle X_j, Y_j \rangle$ such that for each j , X_j asymmetrically c -commands Y_j . d is the non-terminal-to-terminal dominance relations: For a given non-terminal X , $d(X)$ is the set of terminals that X dominates, and for a given ordered pair of non-terminals $\langle X, Y \rangle$, $d\langle X, Y \rangle$ is the set of ordered pairs $\{ \langle a, b \rangle \mid a \text{ is a member of } d(X) \text{ and } b \text{ is a member of } d(Y) \}$.

Given the LCA, and if we take the "linear ordering" as temporal precedence relations, it follows that the number of specifiers and the number of complements are each at most one per head, and that a head precedes its complement and follows its specifier, as schematically shown in (85).

- (85) [HP Specifier [H Complement]]

This entails that there is no head final language in the ordinary sense, and the SOV order of so-called head final languages such as Japanese cannot be the base order. Kayne suggests deriving the SOV order from the underlying SVO order by fronting O across V . In languages like German and Dutch where the finite V overtly raises to AGRs, the landing sites of S and O must be to the left of AGRs (Kayne 1994: 36). If nothing more happens, we obtain an SOV clause with the Complementizer preceding S , as in (86).

- (86) [CP C [IP S_i O_j V (t_i) (t_v) t_j]]

If the IP in this structure raises to the Spec of C , we get (87).

- (87) [CP [IP S_i O_j V (t_i) (t_v) t_j]_k [C t_k]]

Here, V and C are string-adjacent, but they do not form a constituent. This, according to Kayne, may be the structure of agglutinative languages such as Japanese.

As we have seen in the preceding sections, in Japanese the subject and the object form a constituent that excludes the verbal complex at the point of SPELL-OUT. I have concluded from this that Japanese is an overt V-to-I-to-C language, as schematized in (88).

(88) [CP [IP ... S ... O ...] V-I-C]

In this structure, IP is the constituent that dominates the subject and the object but excludes the verb and the complementizer. In the structures in (86) and (87), in contrast, there is no such constituent. Thus, they cannot be the correct structure of Japanese.

This does not mean, however, that Japanese cannot be a head initial language. If V raises to C, and if IP raises to the Spec of C, the resultant structure is SOV, with IP dominating the subject and the object but excluding the verb and the complementizer, even if Japanese is head initial. This is illustrated in (89).

(89) [CP [IP ... S ... O ...]_i [C' V-I-C t_i]]

Thus, if it is a head initial language as Kayne's LCA entails, Japanese still must have overt V-to-C Raising, as I have argued based on the assumption that it is a head final language. And if Japanese is an overt V-to-C language, the IP-internal structure of Japanese can be identical to what I have been arguing for except for the head-complement ordering, which does not yield a phonetic difference given the overt V-to-C.

4. Conclusion

To summarize, I have shown that verbs in Japanese raise out of the VP in overt syntax. This result lends credence to analyses that crucially assume overt V-Raising. I have also discussed six related topics, and reached the following conclusions: i) Restructuring is an overt syntactic process in Japanese, as in some Romance languages. ii) the complex predicate formation takes place before SPELL-OUT. iii) the Proper Binding Condition does not exist as a specific syntactic condition, as we would expect, given the spirit of the minimalist program. iv) contrary to the widely held view, remnant scrambling is possible in Japanese. v) the standard "evidence" for the constituency of *NP-Case+NQ* turns out to be non-evidence. vi) if Kayne's (1994) LCA is correct at all, Japanese must have overt Raising of V to C and of IP to the Spec of C.

Appendices to Chapter Seven

A. Numeral Quantifiers and the Conjunctive Particle

The conjunctive particle *to* "and" in Japanese, like many other particles in this language, is a phonological clitic. It cliticizes to the element immediately preceding it, as shown in (90).

(90) X-*to*

The X here must be a nominal-like element. Thus, *to* cannot occur to the immediate right of an adjective or a case marker, as shown in (92).

(91) *X-*to*, unless X is a nominal-like category

- (92) a. [N ringo]-**to** mikan-o (tabeta)
apple-and orange-ACC (ate)
'(someone ate) apples and oranges'
- b. * ringo-[case marker o]-**to** mikan-o (tabeta)
apple ACC-and orange-ACC (ate)
- c. * [A akai]-**to** aoi ringo-o (tabeta)
red-and blue apple-ACC (ate)
'(someone ate) red and green apples.'
- d. akai [N ringo]-**to** aoi ringo-o (tabeta)
red apple-and blue apple-ACC (ate)
'(someone ate) red apples and green apples'

Numeral quantifiers count as "nominal-like" element for the purpose of the morpho-phonological filter (91). Thus, unlike (92)b, where *to* "and" is cliticized to the accusative case marker, (93) is grammatical.

(93) ringo-o [NQ 3-tu]-**to** mikan-o (2-tu) (tabeta)
apple-ACC 3-CL-and orange-ACC (2-CL) (ate)
'(someone ate) three apples and (two) oranges'

The copula *da* "be" is subject to a similar (but somewhat weaker) morpho-phonological constraint. Thus, when we construct examples with a coordinate structure (or a clefting),

we must make sure that they do not violate the condition in (91). It is for this reason that most of the examples in this chapter contain numeral quantifiers.

Japanese has another "conjunctive particle", i.e. *sosite* "and". Unlike *to*, *sosite* is not a clitic, hence it is not subject to the condition in (91). Thus, other things being equal, *sosite* would better serve for our experiments. For example, I argued in § 1.2. that (94) suggests that the verb overtly raises as in (95).

- (94) Mary-ga [[John-ni ringo-o 2-tu] to [Bob-ni banana-o 3-bon]]
Mary-NOM [[John-to apple-ACC 2-CL] and [Bob-to banana-ACC 3-CL]]
 ageta (koto)
 gave (the fact)
 '(the fact that) Mary gave two apples to John and three bananas to Bob.'

- (95) Schematic structure of (94)
 Subject [[VP IO DO t_v] and [VP IO DO t_v]] V-Tense
 |—————| ↑

If we use *sosite*, instead of *to*, the numeral quantifiers can be dropped, thereby making the example simpler.

- (96) Mary-ga John-ni ringo-o (2-tu), **sosite** Bob-ni banana-o (3-bon),
Mary-NOM John-to apple-ACC (2-CL) and Bob-to banana-ACC (3-CL)
 ageta (koto)
 gave (the fact)

Other things are not equal, however. What is crucial for our purposes is that the process shown in (95) is syntactic movement. Examples with *to* satisfy this requirement. Thus, as we saw in §1, the following example with *to* is ungrammatical because the embedded verbs cannot raise to matrix positions across the tensed clause boundary, a familiar situation found in other languages as well.

- (97) * [[Mary-ga John-ga ringo-o 2-tu] to [Nancy-ga Bob-ga
 [[Mary-NOM John-NOM apple-ACC 2-CL] and [Nancy-NOM Bob-NOM
 banana-o 3-bon]]; katta to omotteiru
banana-ACC 3-CL]] bought that believe

Lit. '[[Mary John two apples] and [Nancy Bob three bananas]] believes that bought.'

(Mary believes that John bought two apples, and Nancy believes that Bob bought three bananas.)

However, if we replace *to* with *sosite*, the example becomes acceptable:

- (98) Mary-ga John-ga ringo-o 2-tu, **sosite** Nancy-ga Bob-ga
Mary-NOM John-NOM apple-ACC 2-CL and Nancy-NOM Bob-NOM
banana-o 3-bon katta to omotteiru
banana-ACC 3-CL bought that believe

Lit. 'Mary John two apples, and Nancy Bob three bananas, believes that bought.'

(Mary believes that John bought two apples, and Nancy believes that Bob bought three bananas.)

If the matrix subjects are marked with the topic marker *wa*, the sentence becomes even better:

- (99) Mary-wa John-ga ringo-o 2-tu, **sosite** Nancy-wa Bob-ga
Mary-TOP John-NOM apple-ACC 2-CL and Nancy-TOP Bob-NOM
banana-o 3-bon katta to omotteiru
banana-ACC 3-CL bought that believe

Lit. 'Mary John two apples, and Nancy Bob three bananas, believes that bought.'

(Mary believes that John bought two apples, and Nancy believes that Bob bought three bananas.)

These cases suggest that examples with *sosite* cannot be used as a test for verb raising. The following sentence also demonstrates that *sosite* should not be used as a constituency test.

- (100) Mary-wa Stanford-no ~~igakubu-ni~~ ~~hairi~~, **sosite**
Mary-TOP Stanford-GEN ~~medical school-to enter~~, and
John-wa Harvard-no, igakubu-ni ~~haitta~~
John-TOP Harvard-GEN medical school-to entered

Lit. 'Mary ~~entered~~ Stanford's ~~medical school~~, and John entered Harvard's medical school.'

In (100), the materials placed in strike-out are optional. Since they are not a syntactic constituent, and since it is generally impossible to syntactically extract "noun + postposition", stranding a genitive modifier of that noun, whatever process responsible for this optionality is not sensitive to syntactic constituency, and it cannot be a syntactic movement.²² This shows that the examples with *sosite* such as (96) need not be derived by syntactic movement, hence they cannot be used to detect syntactic head movement.

B. On the Uncleftability of the Lower VP in English

In his seminal paper (Larson 1983), Larson suggests that the dative construction illustrated in (101)a has the VP-structure in (101)b.

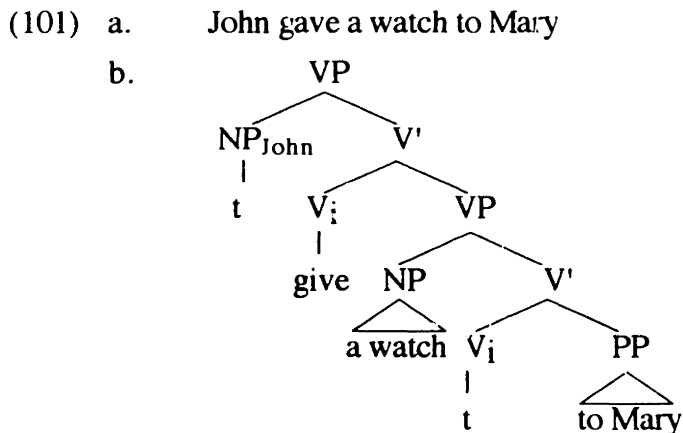

Larson argues that given this analysis, examples like (102) are understood straightforwardly as coordination of the lower VPs.

(102) John gave a watch to Mary and a book to Sue.

This analysis is basically the same as our analysis of Japanese examples like (103) proposed in § 1.

²² Probably the examples in (98) to (100) involve PF deletions operating on strings of words and morphemes.

(103) Mary-ga [[John-ni ringo-o 2-tu] to [Bob-ni banana-o 3-bon]]
Mary-NOM [[John-to apple-ACC 2-CL] and [Bob-to banana-ACC 3-CL]]
 ageta (koto)
gave
 'Mary gave two apples to John, and three bananas to Bob.'

(104) Schematic structure of (103)
 Subject [[VP IO DO t_v] and [VP IO DO t_v]] V-Tense
 |_____ |↑

As a further support of the overt verb raising out of the VP, I presented the following cleft sentence, in which the remnant lower VP is in the focus position.

(105) Mary-ga age-ta no-wa [John-ni ringo-o 3-tu] da
Mary-NOM give-PAST NL-TOP [John-to apple-ACC 3-CL] be
 Lit. 'It is [three apples to John] that Mary gave.'

Other things being equal, we would expect that the lower VP in (101) can be clefted. This prediction fails, as shown in (106).

(106) *It is a watch to Mary that John gave.

This is because in English verb phrases in general cannot be clefted. Thus, as shown in (107), even the higher VP cannot be clefted, though it may be a conjunct.

(107) a. * It is give a watch to Mary that John did.
 b. Mary promised that she will give \$100 to WGBH and donate \$50 to Boston Symphony Orchestra.

A difference arises in the pseudo-cleft construction between the upper VP and the lower VP. As shown in (108), the upper VP may be pseudo-clefted but not the lower VP.

(108) a. What John did was give a watch to Mary.
 b. * What John gave was a watch to Mary.

Daniel Fox (personal communication) suggested to me that it may be that only semantically saturated categories can be the focus of the (pseudo-)cleft construction. The upper VP is a Complete Functional Complex in the sense of Chomsky (1986a), hence it is semantically saturated. The lower VP, in contrast, is only a part of a CFC, thus it is semantically unsaturated. This may be responsible for the contrast shown in (108).²³

C. Traces Not Created by Movement

The focus constituent of the cleft construction such as (109) contains a trace of the verb, and a trace of the subject as well under some analyses.

- (109) *Mary_i-ga age_v-ta no-wa [(t_j) John-ni ringo-o 3-tu t_v] da (=1)b*
Mary-NOM give-Past NL-TOP [(t_j) John-to apple-ACC 3-CL t_v] be
 Lit. 'It is [three apples to John] that Mary gave.'

Similarly, the following English sentences seem to have traces in the focus constituent.

- (110) a. What John_i did was [t_j send a note to Becky]
 b. What Mary_i is [(t_j) is (t_j) likely (t_j) to t_j win] (Howard Lasnik p.c.)

The traces in focused constituents raise three mutually related questions: i) How are they "connected" to their antecedents in terms of their interpretations? and ii) How are they bound? iii) How are they generated? I suggested in § 3.3 that traces created by A-movement need not be bound. Thus, our answer to ii) is that they need not be bound. The other two issues, i.e. i) and iii) do not seem to have definite answers at this moment.

The first question is parallel to the one arising in "binding" cases such as (111), in which the reflexive pronoun is not c-commanded by its antecedent.

- (111) What Nancy_i bought was [a picture of herself_i]

This is different from the regular reconstruction examples such as (112), which might be handled by a copy theory of movement along the lines suggested in Chomsky (1993b).

²³ If this account of the ungrammaticality of (108)b is correct, then what is clefted in (105) must be the upper VP (or some larger phrase) rather than the lower VP.

(112) [Which picture of herself]_i]j did Nancy_i buy t_j

As for the question of how traces in focused constituents are created, one possibility is to derive (110)a, for example, from a structure like (113) by moving the focused constituent to the focus position, to revive and update the analysis by Higgins (1973).

(113) What John_i did [t_j send a note to Becky] was
|—————↑

This analysis also answers the question i). A potential problem with this analysis is that the putative focus movement will be a lowering operation, which is not allowed under the current assumptions. Another problem is how to generate the wh-phrase in the sentence initial position.

Another conceivable analysis of the pseudo-cleft construction in question is that there is a PRO instead of a trace, as shown in (114) (cf. Lasnik and Saito 1992: 140).

(114) What_i John_j did t_i was [PRO_j send a note to Becky]

This is plausible on the ground that Controlled PRO is possible in the pseudo-clefted constituent, as shown in (115).

(115) What_i John_j promised t_i was [PRO_j to win the race] (Howard Lasnik, p.c.)

Unfortunately, the PRO analysis cannot be extended to the Japanese cases shown above which contain traces of a verb, which cannot possibly be PRO.

A third possibility, suggested by Howard Lasnik (personal communication), is to assume that an item listed in Numeration just once may be used twice. Thus, the structure of (110)a is actually (116).

(116) What_i John_j did t_i was [John_j send a note to Becky]

In this case, *John*, which is listed in Numeration only once, has been used twice, once when it is merged with *send a note to Becky*, and once when it is merged with *did was*

The two copies of the same item are interpreted as members of a single chain, and only one of them gets pronounced. This suggestion leads to abandonment of the hypothesis that traces are created only by movement, and adaptation of an interpretive theory of traces. Once we open up this possibility, there are numerous conceivable approaches to the three issues raised at the outset of this appendix. We must leave a careful study of them for future research.

REFERENCES

- Abe, Jun. 1993. *Binding Conditions and Scrambling Without A/A' Distinction*. Doctoral dissertation, University of Connecticut, Storrs.
- Adams, Marianne. 1984-85. Multiple interrogation in Italian. *The Linguistic Review* 4: 1-27.
- Andrews, Avery D. 1983. A note on the constituent structure of adverbials and auxiliaries. *Linguistic Inquiry* 13: 313-317.
- Authier, J.-Marc. 1991. V-Governed expletives, Case Theory, and the Projection Principle. *Linguistics Inquiry* 22: 721-740.
- Authier, J.-Marc. 1992. Iterated CPs and embedded topicalization. *Linguistic Inquiry* 23: 329-336.
- Baker, Mark C. 1988. *Incorporation: A Theory of Grammatical Function Change*. Chicago: University of Chicago Press.
- Baltin, Mark. 1982. A landing site theory of movement rules. *Linguistic Inquiry* 13: 1-38.
- Barss, Andy. 1986. *Chains and Anaphoric Dependence*. Doctoral dissertation, MIT, Cambridge, MA.
- Besten, Hans den and Gert Webelhuth. 1990. Stranding. In *Scrambling and Barriers*, eds. Günther Grewendorf and Wolfgang Sternefeld. Amsterdam: Benjamins. 77-92.
- Bobaljik, Jonathan. 1992. Ergativity, economy and the extended projection principle. Ms. MIT.
- Bobaljik, Jonathan. 1994. What Does Adjacency Do? In *MIT Working Papers in Linguistics 22: The Morphology-Syntax Connection*, eds. Heidi Harley and Colin Phillips. Cambridge, MA: MIT Working Papers in Linguistics. 1-31.
- Bobaljik, Jonathan. 1995. *Morphosyntax: Interface Issues*. Doctoral dissertation, MIT, Cambridge, MA.
- Bobaljik, Jonathan and Andrew Carnie. 1994. A minimalist approach to some problems of Irish word order. To appear. In *Celtic and Beyond*, eds. R. Borsley and I. Roberts. Cambridge: Cambridge University Press.
- Bobaljik, Jonathan and Colin Phillips, eds. 1993. *MIT Working Papers in Linguistics 18: Papers on Case & Agreement I*. Cambridge, MA: MIT Working Papers in Linguistics.
- Boskovic, Zeljko. 1993a. ECP, Spec-head agreement, and multiple wh-movement in overt syntax. Ms. University of Connecticut

- Boskovic, Zeljko. 1993b. On certain violations of the superiority condition, Agro. and economy of derivation. Ms. University of Connecticut.
- Bowers, John. 1976. On surface structure grammatical relations and the structure-preserving hypothesis. *Linguistic Analysis* 2: 225-242.
- Bowers, John. 1993. The syntax of predication. *Linguistic Inquiry* 24: 591-656.
- Branigan, Philip. 1992. *Subjects and Complementizers*. Doctoral dissertation, MIT, Cambridge, MA.
- Burton, Strang and Jane Grimshaw. 1992. Coordination and VP-internal subjects. *Linguistic Inquiry* 23: 305-313.
- Burzio, Luigi. 1986. *Italian Syntax*. Studies in Natural Language and Linguistic Theory Dordrecht: D. Reidel Publishing Company.
- Cheng, Lisa Lai-Shen. 1991. *On the Typology of Wh-questions*. Doctoral dissertation, MIT, Cambridge, MA.
- Chomsky, Noam. 1973. Conditions on transformations. In *A Festschrift for Morris Halle*, eds. S. Anderson and P. Kiparsky. New York: Holt, Rinehart and Winston.
- Chomsky, Noam. 1977. On wh-movement. In *Formal Syntax*, eds. P. Culicover, T. Wasow and A. Akmajian. New York: Academic Press.
- Chomsky, Noam. 1980a. On binding. *Linguistic Inquiry* 11: 1-46.
- Chomsky, Noam, ed. 1981. *Lectures on Government and Binding*. Dordrecht: Foris Publications.
- Chomsky, Noam. 1982. *Some Concepts and Consequences of the Theory of Government and Binding*. Linguistic Inquiry Monographs Cambridge, MA: MIT Press.
- Chomsky, Noam. 1986a. *Knowledge of Language: Its Nature, Origin, and Use*. New York: Praeger.
- Chomsky, Noam. 1986b. *Barriers*. Linguistic Inquiry Monographs 13. Cambridge, MA: MIT Press.
- Chomsky, Noam. 1991. Some notes on economy of derivation and representation. In *Principles and Parameters in Comparative Grammar*, ed. Robert Freidin. Cambridge, MA: MIT Press. 417-454.
- Chomsky, Noam. 1993a. *Language and Thought*. Wakefield, Rhode Island: Moyer Bell.
- Chomsky, Noam. 1993b. A minimalist program for linguistic theory. In *The View from Building 20*, eds. Kenneth Hale and Samuel Jay Keyser. Cambridge, MA: MIT Press. 1-52.
- Chomsky, Noam. 1994. *Bare Phrase Structure*. MIT Occasional Papers in Linguistics 5. Cambridge, MA: MIT Working Papers in Linguistics.

- Chomsky, Noam. 1995. *The Minimalist Program*. Cambridge, MA: MIT Press.
- Chomsky, Noam and Howard Lasnik. 1993. The Theory of Principles and Parameters. In *Syntax: An International Handbook of Contemporary Research*, eds. Joachim Jacobs, Arnim von Stechow, Wolfgang Sternefeld and Theo Vennemann. Berlin: Walter de Gruyter. 506-569.
- Cinque, Guglielmo. 1990. *Types of A'-Dependencies*. Linguistic Inquiry Monographs 17. Cambridge, MA: MIT Press.
- Collins, Chris. 1994. Economy of derivation and the generalized proper binding condition. *Linguistic Inquiry* 25: 45-61.
- Collins, Chris and Höskuldur Thráinsson. 1993. Object shift in double object constructions and the theory of Case. In *Papers on Case & Agreement II*, ed. Colin Phillips. Cambridge, MA: MIT Working Papers in Linguistics. 131-174.
- Comorovski, Ileana. 1986. Multiple wh movement in Romanian. *Linguistic Inquiry* 17: 171-177.
- Culicover, Peter. 1991. Polarity, inversion, and focus in English. In *Proceedings of the Eastern States Conference on Linguistics '91*. 46-68.
- deHaan, Germen and Fred Weerman. 1985. Finiteness and verb fronting in Frisian. In *Verb Second Phenomena in Germanic Languages*, eds. H. Haider and M. Prinzhorn. Dordrecht: Foris. 77-110.
- Delahunty, G. 1983. But sentential subjects exist. *Linguistic Analysis* 12: 379-398.
- Déprez, Viviane M. 1989. *On the Typology of Syntactic Positions and the Nature of Chains*. Doctoral dissertation, MIT, Cambridge, MA.
- Diesing, Molly. 1990. Verb movement and the subject position in Yiddish. *Natural Language and Linguistic Theory* 8: 41-79.
- Emonds, Joseph. 1976. *A Transformational Approach to English Syntax*. New York: Academic Press.
- Emonds, Joseph. 1978. The Verbal Complex V'-V in French. *Linguistics Inquiry* 9: 151-175.
- Emonds, Joseph. 1985. *A Unified Theory of Syntactic Categories*. Dordrecht: Foris.
- Fiengo, Robert. 1977. On trace theory. *Linguistic Inquiry* 8: 35-61.
- Fox, Danny. 1994. Quantifier Scopepe in VP Ellipsis. Ms. MIT.
- Fujita, Koji. 1993. Object movement and binding at LF. *Linguistic Inquiry* 24: 381-388.
- Fujita, Koji. 1994a. Middle, ergative and passive in English: A minimalist perspective. In *MIT Working Papers in Linguistics 22: The Morphology-Syntax Connection*, eds.

- Heidi Harley and Colin Phillips. Cambridge, MA: MIT Working Papers in Linguistics. 71-90.
- Fujita, Koji. 1994b. Double objects, causatives, and the derivational economy. Ms. Osaka University and MIT. (To appear in *Linguistic Inquiry*.)
- Fujita, Naoya. 1994. *On the Nature of Modification: A Study of Floating Quantifiers and Related Constructions*. Doctoral dissertation, University of Rochester, Rochester, NY.
- Fukuhara, Masao. 1993. Case-checking in Japanese. Ms. University of Connecticut.
- Fukui, Naoki. 1986. *A Theory of Category Projection and Its Applications*. Doctoral dissertation, MIT, Cambridge, MA.
- Fukui, Naoki. 1993. A note on the uniformity of form-chain. *The Linguistic Review*
- Fukui, Naoki and Margaret Speas. 1986. Specifiers and projection. In *MIT Working Papers in Linguistics 8: Papers in Theoretical Linguistics*, eds. Naoki Fukui, Tova R. Rapoport and Elizabeth Sagey. Cambridge, MA: MIT Working Papers in Linguistics.
- Greenberg, Gerald R. 1984. Left Dislocation, Topicalization, and Interjections. *Natural Language and Linguistic Theory* 2: 283-287.
- Grimshaw, Jane. 1991. *Argument Structure*. Linguistic Inquiry Monographs 18. Cambridge, MA: MIT Press.
- Haig, John H. 1980. Some observations on quantifier floating in Japanese. *Linguistics* 18: 1065-1083.
- Hale, Kenneth and Samuel Jay Keyser. 1991. *Lexicon Project Working Paper: On the Syntax of Argument Structure*. Cambridge, MA: Center for Cognitive Science, MIT.
- Hale, Kenneth and Samuel Jay Keyser. 1993. On argument structure and the lexical expression of syntactic relations. In *The View from Building 20: Essays in Linguistics in Honor of Sylvain Bromberger*, eds. Kenneth Hale and Samuel Jay Keyser. Cambridge, MA: MIT Press. 53-109.
- Harada, Kazuko. 1972. Constraints on WH-Q binding. *Descriptive and Applied Linguistics* 5: 180-206.
- Harada, S.-I. 1973. Counter equi NP deletion. In *Annual Bulletin*. Research Institute of Logopedics and Phoniatrics, University of Tokyo. 113-147.
- Harley, Heidi. 1994. The Case of the Icelandic Experiencer. Ms. MIT.
- Harley, Heidi. 1995. The Minimalist Japanese Causative. Ms. MIT.
- Higgins, Roger. 1973. *The Pseudo-cleft Construction in English*. Doctoral dissertation, MIT, Cambridge, MA.

- Hoekstra, Teun. 1984. *Transitivity: Grammatical Relations in Government-Binding Theory*. Dordrecht: Foris Publications.
- Hoji, Hajime. 1987. Two types of cleft in Japanese, Paper presented at University of Southern California. Ms. University of Massachusetts, Amherst.
- Hoji, Hajime. 1994. Null object construction and sloppy identity in Japanese. Ms. University of Southern California.
- Holmberg, Anders. 1986. *Word Order and Syntactic Features in the Scandinavian Languages and English*. Doctoral dissertation, University of Stockholm, Stockholm.
- Hooper, Joan B. and Sandra A. Thompson. 1973. On the applicability of root transformations. *Linguistic Inquiry* 4: 465-497.
- Hoshi, Hiroto. 1994. *Passive, Causative, and Light Verbs: A Study of Theta Role Assignment*. Doctoral dissertation, University of Connecticut, Storrs.
- Huang, James. 1982. *Logical Relations in Chinese and the Theory of Grammar*. Doctoral dissertation, MIT, Cambridge, MA.
- Huang, James. 1987a. Comments on Hasegawa's paper. In *Proceedings of the Japanese Syntax Workshop*, eds. Wako Tawa and Mineharu Nakayama. New London: Connecticut College.
- Huang, James. 1987b. Verb-second in German and some AUX phenomena in Chinese. In *Chinese-Western Encounter: Festschrift for Franz Giet, SVD on his 85th Birthday*, ed. A. Bramkamp. Taipei: Fu Jen University.
- Huang, James. 1993. Reconstruction and the structure of VP: Some theoretical consequences. *Linguistic Inquiry* 24: 103-138.
- Hung, Henrietta J. 1988. The structure of derived nouns and verbs in Malagasy: A syntactic account. Ms. McGill University.
- Iatridou, Sabine. 1990. About Agr(P). *Linguistic Inquiry* 21: 551-577.
- Iatridou, Sabine and Anthony Kroch. 1993. The licensing of CP-recursion and its relevance to the Germanic verb-second phenomena. Ms. University of Pennsylvania.
- Iwakura, Kunihiro. 1978. On root transformations and the structure-preserving hypothesis. *Linguistic Analysis* 4: 321-364.
- Izvorski, Roumyana. 1993. On wh-movement and focus-movement in Bulgarian. Paper presented at CONSOLE 2, University of Tuebingen, Dec. 1993.
- Jackendoff, Ray. 1971. Gapping and Related Rules. *Linguistic Inquiry* 2: 21-36.

- Jackendoff, Ray S. 1972. *Semantic Interpretation in Generative Grammar*. Current Studies in Linguistics 2. Cambridge, MA: MIT Press.
- Jacobsen, W.M. 1992. *The Transitive Structure of Events in Japanese*. Studies in Japanese Linguistics 1. Tokyo: Kurosio Publishers.
- Johnson, Kyle. 1991. Object positions. *Natural Language and Linguistic Theory* 9: 577-636.
- Johnson, Kyle. 1992. On the typology of the V^AAdverb^{NP} word order. Ms. University of Wisconsin-Madison.
- Johnson, Kyle. 1994. Bridging the gap. Ms. University of Massachusetts, Amherst.
- Jonas, Dianne and Jonathan Bobaljik. 1993. Specs for subjects: The role of TP in Icelandic. In *Papers on Case & Agreement I*, eds. Jonathan D. Bobaljik and Colin Phillips. Cambridge, MA: MIT Working Papers in Linguistics. 59-98.
- Kageyama, Taro. 1982. Word formation in Japanese. *Lingua* 57: 215-258.
- Kageyama, Taro. 1989. The place of morphology in the grammar. *Yearbook of Morphology* 2: 73-94.
- Kageyama, Taro. 1993. *Bunpo to Gokeisei [Grammar and Word Formation]*. Kasukabe: Hituzi Syobo.
- Kamio, Akio. 1977. Suuryooshi-no shintakusu [Syntax of numeral quantifiers]. *Gengo* 6: 83-91.
- Kayne, Richard. 1984. *Connectedness and Binary Branching*. Studies in Generative Grammar 16. Dordrecht: Foris Publications.
- Kayne, Richard. 1985a. Principles of particle constructions. In *Grammatical Representation*, ed. Jacqueline Guéron et al. Dordrecht: Foris Publication.
- Kayne, Richard. 1985b. L'accord du participe passé en Français et en Italien. *Modueles Linguistiques* 7: 73-89.
- Kayne, Richard. 1989. Facets of past participle agreement in Romance. In *Dialect Variation in the Theory of Grammar*, ed. P Beninca. Dordrecht: Foris Publication.
- Kayne, Richard. 1994. *The antisymmetry of syntax*. Linguistic Inquiry Monograph 25. Cambridge, MA: MIT Press.
- Keyser, Samuel J. and Thomas Roeper. 1984. On the middle and ergative constructions in English. *Linguistic Inquiry* 15: 381-416.
- Kitagawa, Yoshihisa. 1986. *Subjects in Japanese and English*. Doctoral dissertation, University of Massachusetts, Amherst, MA.
- Kitahara, Hisatsugu. 1992. Checking theory and scope interpretation without quantifier raising. In *Harvard Working Papers in Linguistics 1*, eds. Susumu Kuno and

- Höskuldur Thráinsson. Cambridge, MA: Department of Linguistics, Harvard University. 51-71.
- Kitahara, Hisatsugu. 1992. Numeral classifier phrases inside DP and the specificity effect. In *Japanese/Korean Linguistics 3*, ed. Soonja Choi. Stanford: Center for the Study of Language and Information, Stanford University. 171-186.
- Kitahara, Hisatsugu. 1994. Restricting ambiguous rule-application: A unified analysis of movement. In *MIT Working Papers in Linguistics 24: Formal Approaches to Japanese Linguistics 1*, eds. Masatoshi Koizumi and Hiroyuki Ura. Cambridge, MA: MIT Working Papers in Linguistics. 179-210.
- Kitahara, Hisatsugu. 1994. *Target α : A Unified Theory of Movement and Structure-Building*. Doctoral dissertation, Harvard University, Cambridge, MA.
- Koizumi, Masatoshi. 1990. Secondary depictive predicates in Japanese. In *Proceedings of the First Meeting of the Formal Linguistics Society of Midamerica*, eds. Dennis Meyer, Satoshi Tomioka and Leyla Zidani-Eroglu. Madison: University of Wisconsin -- Madison. 145-160.
- Koizumi, Masatoshi. 1991. Modal phrase and types of movements, Paper presented at Japanese/Korean Linguistics 2, at UC Santa Barbara, September 1991. Ms. MIT.
- Koizumi, Masatoshi. 1993a. On the position of object AGR. Ms. MIT.
- Koizumi, Masatoshi. 1993b. A split VP hypothesis. Ms. MIT.
- Koizumi, Masatoshi. 1993c. Object agreement phrases and the split VP hypothesis. In *Papers on Case and Agreement 1*, eds. Jonathan Boškajik and Colin Phillips. Cambridge, MA: MIT Working Papers in Linguistics. 99-148.
- Koizumi, Masatoshi. 1994a. Nominative objects: The role of TP in Japanese. In *MIT Working Papers in Linguistics 24: Formal Approaches to Japanese Linguistics 1*, eds. Masatoshi Koizumi and Hiroyuki Ura. Cambridge, MA: MIT Working Papers in Linguistics.
- Koizumi, Masatoshi. 1994b. Secondary predicates. *Journal of East Asian Linguistics 3*: 25-79.
- Koopman, Hilda and Dominique Sportiche. 1991. The positions of subjects. *Lingua 85*: 211-258.
- Kratzer, Angelika. 1994. On external arguments. In *University of Massachusetts Occasional Papers 17: Functional Projections*, eds. Elena E. Benedicto and Jeffrey T. Runner. Amherst: Graduate Linguistic Student Association. 103-130.
- Kroch, Anthony. 1989. Amount quantification, referentiality, and long wh-movement. Ms. University of Pennsylvania.
- Kuno, Susumu. 1973. *The Structure of the Japanese Language*. Current Studies in Linguistics Series 3. Cambridge, MA: MIT Press.

- Kuroda, S.-Y. 1965. *Generative Grammatical Studies in the Japanese Language*. Doctoral dissertation, MIT, .
- Kuroda, S.-Y. 1978. Case marking, canonical sentence patterns, and counter equi in Japanese. In *Problems in Japanese Syntax and Semantics*, eds. J. Hinds and I. Howards. Tokyo: Kaitakusha.
- Kuroda, S.-Y. 1980. Bunkoozoo-no hikaku. In *Nitieigo Hikaku-Kooza 2: Bunpoo*, ed. T. Kunihiro. Tokyo: Taishukan.
- Kuroda, S.-Y. 1983. What can Japanese say about government and binding. In *WCCFL 2*, ed. M. Barlow.
- Kuroda, S.-Y. 1988. Whether we agree or not: A comparative syntax of English and Japanese. *Linguisticae Investigationes* 12: 1-47.
- Kuwabara, Kazuki. 1992. *The Syntax of A'-Adjunction and Conditions on Chain-Formation*. Doctoral dissertation, Dokkyo University, Soka.
- Laka, Itziar. 1990. *Negation in Syntax: On the Nature of Functional Categories and Projections*. Doctoral dissertation, MIT, Cambridge, MA.
- Larson, Richard. 1988. On the double object construction. *Linguistic Inquiry* 19: 335-392.
- Larson, Richard. 1990. Double object revisited: Reply to Jackendoff. *Linguistic Inquiry* 22: 589-632.
- Lasnik, Howard. 1993. *Lectures on Minimalist Syntax*. Occasional Papers 1. University of Connecticut Working Papers in Linguistics.
- Lasnik, Howard and Mamoru Saito. 1991. On the subject of infinitives. In *CLS 27*.
- Lasnik, Howard and Mamoru Saito. 1992. *Move- α* . Cambridge, MA: MIT Press.
- Levine, Robert. 1984. Against "reanalysis transformation". *Linguistic Analysis* 14: 3-30.
- Lobeck, Anne. 1990. Functional heads and proper governors. In *NELS 20*. 348-362.
- Mahajan, Anoop Kumar. 1990. *The A/A-bar Distinction and Movement Theory*. Doctoral dissertation, MIT, Cambridge, MA.
- Mahajan, Anoop Kumar. 1990. Clitic doubling, object agreement and specificity. In *NELS 21*, ed. Tim Sherer. Amherst, MA: Graduate Student Linguistic Association, Department of Linguistics, University of Massachusetts, Amherst. 263-277.
- Maling, Joan. 1976. Notes on quantifier-postposing. *Linguistic Inquiry* 7: 708-18.
- Maling, Joan. 1978. An asymmetry with respect to wh-islands. *Linguistic Inquiry* 9: 75-89.
- Maling, Joan and Annie Zaenen. 1978. The nonuniversality of a surface filter. *Linguistic Inquiry* 9: 475-497.

- Marantz, Alec. 1993. Implications of asymmetries in double object construction. In *Theoretical Aspects of Bantu Grammar 1*, ed. Sam Mchombo. Stanford: CSLI. 113-150.
- Marantz, Alec. 1995. The Minimalist Program. In *Government and Binding Theory and the Minimalist Program.*, ed. Gert Webelhuth. Oxford: Blackwell Publishers.
- Martin, Roger. 1992. On the distribution and Case features of PRO. Ms. University of Connecticut.
- May, Robert. 1977. *The Grammar of Quantification*. Doctoral dissertation, MIT, Cambridge, MA.
- May, Robert. 1985. *Logical Form: Its Structure and Derivation*. Linguistic Inquiry Monographs 12. Cambridge, MA: MIT Press.
- McCawley, James. 1982. Parentheticals and discontinuous constituent structure. *Linguistic Inquiry* 13: 91-106.
- McCawley, James. 1987. Some additional evidence for discontinuity. In *Syntax and Semantics 20: Discontinuous Constituency*, eds. Geoffrey J. Huck and Almerindo E. Ojeda. New York: Academic Press. 185-200.
- McNally, Louise. 1992. VP coordination and the VP-internal subject hypothesis. *Linguistic Inquiry* 23: 336-341.
- Miyagawa, Shigeru. 1986. Restructuring in Japanese. In *Issues in Japanese Linguistics*, eds. Takashi Imai and Mamoru Saito. Dordrecht: Foris Publications. 273-300.
- Miyagawa, Shigeru. 1989. *Structure and Case Marking in Japanese*. Syntax and Semantics 22. New York: Academic Press.
- Miyagawa, Shigeru. 1991. Case realization and scrambling. Ms. Ohio State University.
- Miyagawa, Shigeru. 1993. Case-checking and Minimal Link Condition. In *Papers on Case and Agreement II*, ed. Colin Phillips. Cambridge, MA: MIT Working Papers in Linguistics. 213-254.
- Miyagawa, Shigeru. 1994. Nonconfigurationality within a configurational structure. Ms. MIT.
- Miyagawa, Shigeru. 1995a. Against VP-adjunction scrambling, Paper presented at the 1995 LSA Annual Meeting. Ms. MIT.
- Miyagawa, Shigeru. 1995b. Against Optional Scrambling. Ms. MIT.
- Miyamoto, Yoichi. 1994. *Secondary Predicates and Tense*. Doctoral dissertation, University of Connecticut, Storrs.
- Moltmann, Friederike. 1992. *Coordination and Comparatives*. Doctoral dissertation, MIT, Cambridge, MA.

- Müller, Gereon. 1993. *On Deriving Movement Types*. Doctoral dissertation, University of Tübingen, Tübingen.
- Müller, Gereon. 1994. A constraint on remnant movement. Ms. University of Tübingen.
- Müller, Gereon and Wolfgang Sternefeld. 1993. Improper movement and unambiguous binding. *Linguistic Inquiry* 24: 461-507.
- Murasugi, Keiko. 1991. *Noun Phrases in Japanese and English: A Study in Syntax, Learnability and Acquisition*. Doctoral dissertation, University of Connecticut, Storrs.
- Nakamura, Masaru. 1994. Topicalization, Neg-Preposing, and Locative Preposing. In *Current Topics in English and Japanese*, ed. Masaru Nakamura. Tokyo: Hituzi Syobo.
- Nakayama, Mineharu and Masatoshi Koizumi. 1991. Remarks on Japanese subjects. *Lingua* 85: 303-319.
- Nakayama, Mineharu and Wako Tawa. 1988. Implicit arguments: Evidence from passive and potentials in Japanese. In *Proceedings of Japanese Syntax Workshop: Issues on Empty Categories*, eds. Wako Tawa and Mineharu Nakayama. New London, Connecticut.
- Nemoto, Naoko. 1993. *Chains and Case Positions: A Study from Scrambling in Japanese*. Doctoral dissertation, University of Connecticut, Storrs.
- Nishigauchi, Taisuke. 1993. Long distance passive. In *Japanese Syntax in Comparative Grammar*, ed. Nobuko Hasegawa. Tokyo: Kuroshio Shuppan. 79-114.
- Noji, Miyuki. 1993. Wadaika to soseisyogo [Topicalization and feature checking]. *The Rising Generation* 139-6.
- Oka, Toshifusa. 1993a. *Minimalism in Syntactic Derivation*. Doctoral dissertation, MIT, Cambridge, MA.
- Oka, Toshifusa. 1993b. Shallowness. In *Papers on Case & Agreement II*, ed. Colin Phillips. Cambridge, MA: MIT Working Papers in Linguistics. 255-320.
- Okada, Hisami. 1989. *Analysis of Two Types of Potential Constructions in Japanese*. M.A. thesis, The Ohio State University, Columbus, Ohio.
- Otani, Kazuyo and John Whitman. 1991. V-Raising and VP-Ellipsis. *Linguistic Inquiry* 22: 345-358.
- Pesetsky, David. 1982. *Paths and Categories*. Doctoral dissertation, MIT, Cambridge, MA.
- Pesetsky, David. 1989. Language-particular process and the earliness principle. Ms. MIT.

- Pesetsky, David. 1994. *Zero Syntax*. Current Studies in Linguistics 27. Cambridge, MA: MIT Press.
- Phillips, Colin, ed. 1993. *MIT Working Papers in Linguistics 19: Papers on Case & Agreement II*. Cambridge, MA: MIT Working Papers in Linguistics.
- Pollock, Jean-Yves. 1989. Verb movement, UG and the structure of IP. *Linguistic Inquiry* 20: 365-424.
- Postal, Paul. 1974. *On Raising*. Cambridge, MA: MIT Press.
- Postal, Paul M. 1969. Anaphoric Islands. In *Chicago Linguistic Society*. 205-239.
- Reinhart, Tanya. 1982. A second COMP position. In *Theory of Markedness in Generative Grammar*, eds. A. Belletti, L. Brandi and L. Rizzi. Pisa: Scuola Normale Superiore di Pisa.
- Rizzi, Luigi. 1982. *Issues in Italian Syntax*. Studies in Generative Grammar 11. Dordrecht: Foris Publications.
- Rizzi, Luigi. 1986. On chain formation. In *Syntax and Semantics 19: The Syntax of Pronominal Clitics*, ed. Hagit Borer. New York: Academic Press.
- Rizzi, Luigi. 1990. *Relativized Minimality*. Linguistic Inquiry Monograph 16. Cambridge, MA: MIT Press.
- Rochemont, Michael. 1989. Topic islands and the subjacency parameter. *Canadian Journal of Linguistics* 34: 145-170.
- Ross, John Robert. 1967. *Constraints on Variables in Syntax*. Doctoral dissertation, MIT, Cambridge, MA.
- Ross, John Robert 1970. Gapping and the order of constituents. In *Progress in Linguistics*, eds. Manfred Bierwisch and Karl E. Heidolph. The Hague: Mouton.
- Rudin, Catherine. 1988a. Multiple questions in South Slavic, West Slavic, and Romanian. *Slavic and East European Journal* 32: 1-24.
- Rudin, Catherine. 1988b. On multiple questions and multiple wh fronting. *Natural Language and Linguistic Theory* 6: 445-501.
- Sadakane, Kumi and Masatoshi Koizumi. 1995. On the Nature of "Dative" Particle *ni* in Japanese. *Linguistics* 33: 5-33.
- Sag, Ivan. 1976. *A Logical Theory of VP Deletion*. Doctoral dissertation, MIT, Cambridge, MA.
- Saito, Mamoru. 1985. *Some Asymmetries in Japanese and Their Theoretical Implications*. Doctoral dissertation, MIT, Cambridge, MA.

- Saito, Mamoru. 1989. Scrambling as semantically vacuous A'-movement. In *Alternative Conception of Phrase Structure*, eds. Mark R. Baltin and Anthony S. Kroch. Chicago: University of Chicago Press.
- Saito, Mamoru. 1992. Long distance scrambling in Japanese. *Journal of East Asian Linguistics* 1: 69-118.
- Saito, Mamoru and Keiko Murasugi. 1990. N'-deletion in Japanese. In *UConn Working Papers in Linguistics 3*. Storrs: Department of Linguistics, University of Connecticut.
- Santorini, Beatrice. 1989. *The Generalization of the Verb-Second Constraint in the History of Yiddish*. Doctoral dissertation, University of Pennsylvania, .
- Santorini, Beatrice. 1992. Variation and change in Yiddish subordinate clause word order.
- Shibatani, Masayoshi. 1978. *Nihongo no Bunseki [Analysis of Japanese]*. Tokyo: Taishukan Shoten.
- Snyder, William. 1992. Chain-formation and crossover. Ms. MIT.
- Snyder, William and Pierre Pica. 1994. Weak crossover, scope, and agreement in a minimalist framework. *WCCFL* 13.
- Speas, Margaret J. 1990. *Phrase Structure in Natural Languages*. Dordrecht: Kluwer.
- Speas, Peggy. 1991. Functional heads and inflectional morphemes. Ms. University of Massachusetts, Amherst. (Paper presented at GLOW 1991, Leiden).
- Sportiche, Dominique. 1988. A theory of floating quantifiers and its corollaries for constituent structure. *Linguistic Inquiry* 19: 425-449.
- Sportiche, Dominique. 1990. Movement, Agreement and Case. Ms. UCLA.
- Stowell, Timothy Angus. 1981. *Origins of Phrase Structure*. Doctoral dissertation, MIT, Cambridge, MA.
- Sugioka, Yoko. 1984. *Interaction of Derivational Morphology and Syntax in Japanese and English*. Doctoral dissertation, The University of Chicago, Chicago.
- Szabolcsi, Anna and Frans Zwarts. 1992-1993. Weak islands and an algebraic semantics for scope taking. *Natural Language Semantics* 2.
- Tada, Hiroaki. 1992. Nominative objects in Japanese. *Journal of Japanese Linguistics* 14: 91-108.
- Tada, Hiroaki. 1993. *A/A-bar Partition in Derivation*. Doctoral dissertation, MIT, Cambridge, MA.
- Takahashi, Daiko. 1993. On antecedent-contained deletion. Ms. University of Connecticut.

- Takahashi, Daiko. 1994. *Minimality of Movement*. Doctoral dissertation, University of Connecticut, Storrs.
- Takano, Yuji. 1994. Scrambling, relativized minimality, and economy of derivation. In *Proceedings of WCCFL 13*.
- Takano, Yuji. 1995. Predicate fronting and internal subject. *Linguistic Inquiry* 26.
- Takezawa, Koichi. 1987. *A Configurational Approach to Case-Marking in Japanese*. Doctoral dissertation, University of Washington.
- Terada, Michiko. 1990. *Incorporation and Argument Structure in Japanese*. Doctoral dissertation, University of Massachusetts, Amherst, .
- Tersis-Surugue, Nicole. 1981. *Économie D'un Système: Unités et Relations Syntaxiques en Zarma*. Selafr-Paris: Center National de la Recherche Scientifique et l'Agence de Coopération Culturelle et Technique.
- Thráinsson, Höskuldur. 1979. *On Complementation in Icelandic*. Doctoral dissertation, Harvard University, Cambridge, MA.
- Thráinsson, Höskuldur. 1985. V1, V2, V3 in Icelandic. In *Verb Second Phenomena in Germanic Languages*, eds. H. Haider and M. Prinzhorn. Dordrecht: Foris. 169-194.
- Toyoshima, Takashi. 1991. *A-bar dependencies, clause structure, and the system of subordination*. Gengo Kenkyu 10. Kyoto University. 79-167.
- Travis, Lisa. 1984. *Parameters and Effects of Word Order Variation*. Doctoral dissertation, MIT, Cambridge, MA.
- Travis, Lisa. 1988. The syntax of adverbs. In *McGill Working Papers in Linguistics: Proceedings of the IVth Workshop on Comparative Germanic Syntax*, . Montreal: McGill University.
- Travis, Lisa. 1992a. Derived objects, inner aspect, and the structure of VP, (Presented at NELS XXII, University of Delaware). Ms. McGill University.
- Travis, Lisa. 1992b. Negation within the VP. Ms. McGill University.
- Tsai, Wei-Tien. 1994. *On Economizing the Theory of A-bar Dependencies*. Doctoral dissertation, MIT, Cambridge, MA.
- Ueda, Masanobu. 1986. On quantifier float in Japanese. In *University of Massachusetts Occasional Papers in Linguistics 11: Oriental Linguistics*, eds. Nobuko Hasegawa and Yoshihisa Kitagawa. Amherst: Graduate Student Linguistic Association. 263-309.
- Ura, Hiroyuki. 1993. On feature-checking for *wh*-traces. In *Papers on Case and Agreement I*, eds. Jonathan Bobaljik and Colin Phillips. Cambridge, MA: MIT Working Papers in Linguistics. 215-242.

- Ura, Hiroyuki. 1994a. *Varieties of Raising and the Feature-Based Bare Phrase Structure Theory*. MIT Occasional Papers in Linguistics 7. Cambridge, MA: MIT Working Papers in Linguistics.
- Ura, Hiroyuki. 1994b. A parametric approach to the typological variety of the double object construction. Ms. MIT.
- Vikner, Sten. 1991. *Verb Movement and the Licensing of NP-Positions in the Germanic Languages*. Doctoral dissertation, University of Geneva, Geneva.
- Watanabe, Akira. 1993. *AGR-Based Case Theory and Its Interaction with the A-bar System*. Doctoral dissertation, MIT, Cambridge, MA.
- Wexler, Kenneth and Peter Culicover. 1980. *Formal Principles of Language Acquisition*. Cambridge, MA: MIT Press.
- Whitman, John. 1991. String vacuous V to COMP, (Presented at GLOW, March 26, 1991). Ms. Cornell University.
- Williams, Edwin. 1977a. Discourse and logical form. *Linguistic Inquiry* 8: 101-139.
- Williams, Edwin. 1977b. Across-the-board application of rules. *Linguistic Inquiry* 8: 419-423.
- Williams, Edwin. 1978. Across-the-board rule application. *Linguistic Inquiry* 9: 31-43.
- Williams, Edwin. 1981. Argument structure and morphology. *The Linguistic Review* 1: 81-114.
- Yoshimura, Noriko. 1992. *Scrambling and Anaphora in Japanese*. Doctoral dissertation, University of Southern California, Los Angeles.
- Yoshimura, Noriko. 1994a. 'Ga' to 'No' no Mondai [Issues of 'Ga' and 'No']. *Gengo Kenkyu* 105: 170-171.
- Yoshimura, Noriko. 1994b. 'Ga' no Mondai [Issues of 'Ga']. In *Henyooosuru Gengo Bunka Kenkyuu*. Shizuoka: University of Shizuoka. 13-28.
- Zaenen, Annie. 1985. *Extraction Rules in Icelandic*. Doctoral dissertation, Harvard University, Cambridge, MA.
- Zagona, Karen. 1988. *Verb Phrase Syntax: A Parametric Study of English and Spanish*. Dordrecht: Kluwer Academic Publishers.
- Zubizarreta, Maria Luisa. 1982. *On the Relationship of the Lexicon and Syntax*. Doctoral dissertation, MIT, Cambridge, MA.