

THE UNIVERSITY OF YAOUNDE I

UNIVERSITE DE YAOUNDE I

Faculty of Arts, Letters and Social Sciences
Faculté des Arts, Lettres et Sciences Humaines

**Department of Linguistics and African
Languages**

*Département de Linguistique et Langues
Africaines*



ASPECTS OF CLEFTING IN LAMNSO'

*A dissertation submitted in partial fulfilment of the requirements for the award
of the Post-graduate Diploma (Maîtrise) in Linguistics*

by

BONAVENTURE MBIYDZENYUY SALA

B A English / French (Yaounde)

Supervised by

EDMOND BILOA

Ph. D. (USC)

Assistant Professor, University of Yaounde I

Yaounde, September 1999

DEDICATION

To Maxeline WANYU

ACKNOWLEDGEMENTS

I must thank my supervisor, Dr Edmond BILOA, for igniting the love for syntax in me, for generously allowing me to use his library and for sacrificing time out of his busy schedule for this study. I equally thank the rest of my lecturers in the Department of Linguistics and African Languages, University of Yaounde I, for their constant attention both in class and in the course of this study. Thanks are also due to the library of SIL, Cameroon, for providing some of the documentation that has guided this work. The following friends merit special mention here for encouraging me after I discussed sections of this work with them : Christopher BERNSAH, Francis VERNYUY, Eric AWAH LONGLA, Linus AZONGMBI, Roland NGANG, Frida KONG and Walters SONG. I also thank Celestine TATA of the Geography Department, University of Yaounde I for providing the maps used in the study. The enviable typing and typesetting is the work of Pierre PEDJUI of MOKAF in Bonamoussadi. Obviously, none of the people mentioned above could be held responsible for any deficiency in the final version of this study for which I assume full responsibility.

B. M. SALA

Yaounde, 1999.

ABSTRACT

This work set out to probe into some aspects of clefting in Lamnso'. Data was collected through a comparative analysis of some Lamnso' and English sentences. Though there are some similarities in cleft constructions in Lamnso' and English, the focus of the work was on dissimilarities. Clefting in Lamnso' involves two processes, namely V-preposing and the occurrence of the copula. V-preposing, accompanied by heads such as TNS and NEG, is used to focus subject NPs. AGR disappears after V-preposing, the case grid of the preposed verb is modified and a kind of 'makeshift' accusative case is assigned to [Spec, AGRP]. The moved verb and the accompanying heads land in the F of FP. The occurrence of the copula is used to focus post-verbal constituents such as object NPs, PPs and embedded IPs and CPs. The constituents remain in situ and the copula is generated in front of them. The copula could also be generated in front of relativized V-complements.

LIST OF ABBREVIATIONS

ACCUS.	Accusative case
AGRP	Agreement Phrase
CAUS.	Causative
CL	Class
COMP	Complementizer Position (sentence initial position)
CP	Complementizer Phrase
Det.	Determiner
ECM	Exceptional Case Marking
ECP	Empty Category Principle
EPP	Extended Projection Principle
FOC	Focus
FP	Focus Phrase
FUT	Future Tense
HMC	Head Movement Constraint
INFL	Nomination Case
INSTR.	Instrumental Case
IP	Inflectional Phrase
NOM.	Nominative Case
NP	Noun Phrase
PP	Prepositional Phrase
QM	Question Marker
RESUMP. Pron.	Resumptive Pronoun
SM	Subject Marker
Spec	Specifier
TNS	Tense
VP	Verb Phrase

TABLE OF CONTENTS

DEDICATION.....	<i>i</i>
ACKNOWLEDGEMENTS.....	<i>ii</i>
ABSTRACT.....	<i>iii</i>
LIST OF ABBREVIATIONS.....	<i>iv</i>
TABLE OF CONTENTS.....	<i>v</i>
TABLE OF FIGURES.....	<i>viii</i>
Chapter One : GENERAL INTRODUCTION.....	1
1.1 BACKGROUND TO THE TOPIC.....	1
1.1.1 OBJECTIVES OF THE STUDY.....	2
1.1.2 SCOPE OF THE STUDY.....	3
1.1.3 RELEVANCE OF THE STUDY.....	3
1.2 METHODOLOGY.....	3
1.3 SOME THEORETICAL ASSUMPTIONS.....	4
1.3.1 GOVERNMENT THEORY.....	4
1.3.2 THETA THEORY.....	5
1.3.3 CASE THEORY.....	6
1.3.4 FOCUS PHRASE.....	7
1.4 PLAN OF WORK.....	8
Chapter Two : PRESENTATION OF THE LANGUAGE.....	9
2.1 PRELIMINARIES.....	9
2.1.1 GEOGRAPHICAL SITUATION OF NSO'.....	9
2.1.2 THE LINGUISTIC CLASSIFICATION OF LAMNSO'.....	12
2.2 PHONOLOGY OF LAMNSO'.....	14
2.2.1 VOWEL SYSTEM.....	14
2.2.2 CONSONANT SYSTEM.....	15

2.3 VERBAL MORPHOLOGY	16
2.3.1 SOME VERBAL TONEMES AND MORPHEMES	17
2.3.1.1 The Present Progressive Tense.....	17
2.3.1.2 The Present Tense	17
2.3.1.3 The Past Tense	18
2.3.1.4 The Future Tense.....	18
2.3.1.5 The Present Perfect Tense.....	18
2.3.1.6 The Future Progressive.....	19
2.3.2 SOME VERBAL EXTENSIONS	19
2.4 THE NOUN CLASS SYSTEM IN LAMNSO'	20
2.5 WORD - ORDER OF LAMNSO'	21
2.5.1 THE SUBJECT NP.....	22
2.5.2 THE VERB PHRASE	23
2.5.2.1 Constituents Left of the VP	23
2.5.2.2 Constituents to the Right of VP	24
2.5.3 OBJECT NPS.....	25
2.5.4 THE PP.....	26
2.6 SENTENCE TYPES	27
2.6.1 DECLARATIVE SENTENCES.....	27
2.6.2 INTERROGATIVE SENTENCES	28
2.6.2.1 Yes / No Questions.....	28
2.6.2.2 WH - Questions.....	28
2.6.3 EMBEDDED SENTENCES.....	29
2.7 SUMMARY	30
Chapter Three : V- PREPOSING AND COPULA INSERTION	31
INTRODUCTION	31
3.1 V-PREPOSING	32
3.1.1 THE USE OF V-PREPOSING	32
3.1.2 PREPOSABLE VERBS	34
3.1.3 ACCOMPANYING CONSTITUENTS	35
3.1.4 THE EFFECT OF V-PREPOSING ON OTHER CONSTITUENTS.....	40

3.1.4.1 The Subject NP	41
3.1.4.2 The AGRP	42
3.1.4.3. The V-Complements	44
3.2 THE OCCURRENCE OF THE COPULA.....	44
3.2.1 USES OF THE OCCURRENCE OF THE COPULA	44
3.2.2 THE EXPLETIVE- <i>a</i>	45
3.2.3 THE OCCURRENCE OF THE COPULA AND OBJECT NPS.....	46
3.2.4 THE OCCURRENCE OF THE COPULA AND PPS.....	48
3.2.5 THE OCCURRENCE OF THE COPULA AND ADJUNCTS.....	49
3.2.6 THE OCCURRENCE OF THE COPULA AND CLAUSES.....	50
3.2.7 <i>a</i> -DELETION IN SENTENCE-INITIAL POSITION	52
3.4 SUMMARY	54
Chapter Four : V-PREPOSING AND SENTENCE STRUCTURE.....	56
INTRODUCTION	56
4.1 THE LANDING SITE OF PREPOSED VERBS	56
4.1.1 SOME PECULIARITIES OF V-MOVEMENT IN LAMNSO'	62
4.2.2 THE LANDING SITE FOR CONSTITUENTS ACCOMPANYING THE PREPOSED VERB.....	66
4.2 V-TRACES AND PROPER GOVERNMENT	69
4.3 THE ASSIGNMENT OF ACCUSATIVE CASE TO [SPEC,AGRP].....	72
4.3.1 THE DISAPPEARANCE OF AGR.....	73
4.3.2 SUBJECT NP AND ACCUSATIVE CASE	74
4.4 V-PREPOSING AND SUBJACENCY	78
4.5 SUMMARY	79
Chapter Five : GENERAL CONCLUSION	81
5.1 SUMMARY OF FINDINGS	81
5.2 V-PREPOSING, THE OCCURRENCE OF THE COPULA AND UNIVERSAL GRAMMAR.....	82
5.3 PARAMETRIC VARIATIONS.....	83
5.4 PROSPECTS FOR FURTHER STUDY	83
BIBLIOGRAPHICAL REFERENCES.....	85

TABLE OF FIGURES

Figure I : <i>Administrative Map of Cameroon</i>	10
Figure II : <i>Map of Bui Division</i>	11
Figure III : <i>Genealogical Tree of Lamnso'</i>	13
Figure IV : <i>Lamnso' vowels</i>	14
Figure V : <i>Lamnso' consonants</i>	15
Figure VI : <i>Noun class classification in Lamnso'</i>	20
Figure VII : <i>Lamnso' personal pronouns</i>	25

GENERAL INTRODUCTION

This chapter introduces the work by talking about the background of the problem, the objectives of the work, its relevance and its scope. It also states the methodology used in data collection and reviews some theories that have been postulated by linguists such as Koopman (1984), Chomsky (1986), Rizzi (1990), Haegeman (1994) and Biloa (1995) to explain the data from other African languages.

1.1 BACKGROUND TO THE TOPIC

Generally, clefting consists in putting the constituents of a sentence into focus. It is used by speakers of natural languages to show the elements on which emphasis is laid in a sentence. It, therefore, supplements other phonological processes such as intonation and word stress. In fact, almost all sentence constituents can be given focus prominence. These include NPs, PPs, VPs and even verbs [in what has been referred to as focus-V-movement as seen in Vata in Koopman (1984) and in Tuki in Biloa (1995)]. In English, cleft constructions involve the structure in (1) below :

(1) It be XP IP

where XP is any constituent fronted out of the IP.

It has been said by Riemsdijk and Williams (1986 : 102) that the cleft construction involves WH-movement because there is a trace in the IP and the movement respects subadjacency.

In Lamnso', clefting has a different formula from (1) above. The formula is stated in (2) below:

(2) Formula for clefting in Lamnso'

V XP

Where XP is any maximal projection, be it an NP, a PP, an IP or a CP.

This formula shows that, for an element to be clefted, a verb has to be placed in front of it. This verb could be the result of V-movement or of the generation of a copula in front of the constituent. Hence, instead of the element moving to some higher IP as shown in (1) above, it is the verb that is moved or inserted in front of the constituent

which is focused and remains in its base position. The verb itself cannot be clefted, that is, predicate clefting is impossible. However, there are many interesting issues that arise from the foregoing that we list here in the form of questions :

- (i)- When the verb moves where does it land? ✓
- (ii)- What happens to its functions in the sentence such as theta-role assignment and case assignment? ✓
- (iii)- With what does it move?
- (iv)- Why does the movement of the verb engender structural changes like the loss of nominative case assigned to the subject NP ? ✓
- (v)- What additional transformations occur when the copula is inserted in front of a constituent ?
- (vi)- How can the empty subject position at sentence-initial position be interpreted?
- (vii)- When the clefting of a V-constituent occurs in sentence-initial position (with a slight shift in meaning) does the copula move with it or is it inserted anew after the relativisation of the constituent has occurred ?
- (viii)- How can these issues be analysed?
- (ix)- What theories and principles of Universal Grammar apply to them and what parametric variations specific to Lamnso' are exhibited?

1.1.1 OBJECTIVES OF THE STUDY

This study aims at analysing and explaining the issues listed above. Accordingly, the work shows that clefting in Lamnso' involves verb movement and the occurrence of the copula and that the moved verb lands in a head position of a phrasal constituent between CP and AGRP and occurs simultaneously with other processes such as WH-fronting and relativisation. The work also aims at analysing other accompanying transformations that occur with and after clefting in Lamnso'. Finally, the work aims at highlighting the aspects of the cleft construction that are attributable to Universal Grammar and those that are parameterised in the language.

1.1.2 SCOPE OF THE STUDY

The focus of this study is the cleft construction in Lamnso' and the various transformations that are triggered by it. Hence, other WH-movement processes such as relativisation and WH-fronting are given little attention. Though, occasionally, reference is made to other processes in Lamnso' to buttress up certain arguments, that should not be interpreted as a broadening of the scope of the work since such areas have not been subjected to research work. Stress is only laid on those aspects of cleft construction that are novel concepts.

1.1.3 RELEVANCE OF THE STUDY

studies in Lamnso'

This study will be a great contribution to Lamnso' studies in the domain of syntax. It should be noticed that very little work has been carried out in the domain. At a broader level, this study will, therefore, ignite and facilitate other studies in the syntax of Lamnso' as well as help researchers who may want to carry out a broader research work than this in other Bantu languages. Since the focus of the work is on novel concepts not found in other Indo-European languages like English, the study highlights some parameters that, if found to apply to other Bantu languages, may lead to a wider understanding of the syntax of Bantu languages. The work shows the difficulties of applying some English-derived theories into African languages, especially at a time when interest seems to be shifting from Indo-European languages to African languages.

1.2 METHODOLOGY

This study is carried out under the guidance of the Theory of Principles and Parameters postulated by Chomsky (1981, 1986, 1991) [see also Haegeman (1994)]. Data was collected through the use of interviews administered to five informants. In analysing the sentences, a comparative analysis of English and Lamnso' sentences was made. The purpose was to find out the areas of disparity. This is in accordance with Chomsky (1965: 6) who says, "it is quite proper for a grammar to discuss only exceptions and the irregularities in any detail". It was from these irregularities that the research problem was arrived at.

1.3 SOME THEORETICAL ASSUMPTIONS

After the foregoing discussion, it is useful to review some theoretical assumptions posited by linguists to be analytical tools of natural languages. This is because they will be used in the analysis of the data from Lamnso'.

1.3.1 GOVERNMENT THEORY

This theory defines the basic structural relationship that underlies constituents or grammatical categories in a sentence. It is stated as follows :

(3) Government

A governs B iff (if and only if)

- (i) A is a governor;
- (ii) A m-commands B;
- (iii) No barrier intervenes between A and B;
- (iv) Minimality is respected.

Where governors are (i) heads,
(ii) co-indexed XPs.

(Haegeman, 1994: 404)

(3i) refers to governors as heads. Heads are X^0 projections of an X-bar system that combine with their complements to form X' and with specifiers to form X'' , the maximal projection. Heads are Ns, Vs, Ps, Cs or Is. (3ii) refers to m-command postulated in Chomsky (1986: 8) and quoted in Haegeman (1994: 152). It is stated as follows:

- (4) A m-commands B iff A does not dominate B and every X that dominates A also dominates B.

In (4), X is a maximal projection and not just any kind of node. So, any XP can be an m-commanding domain for its constituents. Hence, an IP can m-command [spec, IP] and the VP.

maximal projections are barriers.

In (3iii), barriers are maximal projections. IP, referred to in this work as AGRP, is said in the literature to be transparent to outside government. Generally, a node A cannot govern into a maximal projection. Such a node can only govern the whole XP but not constituents or projections contained in it.

The minimality condition on government states that

- (5) A governs B if there is no node Z such that
- (i)- Z is a potential governor for B;
 - (ii)- Z m-commands B;
 - (iii)- Z does not m-command A.

(Rizzi, 1990: 6).

This condition prevents multiple governors where more than one governor compete to govern one X. In such a case, the closest governor wins.

Theta-government is head government and is the result of theta marking. Antecedent government is government by co-indexation and is the result of either movement or interpretation. There is also the requirement that traces must be properly governed. This is known as the empty category principle (ECP) which states as follows :

- (6) Empty category principle

Traces must be properly governed.

A properly governs B iff A theta-governs B or A antecedent governs B.

(Chomsky, 1986: 17).

1.3.2 THETA THEORY

This is part of the knowledge of every native speaker and constitutes part of the knowledge of the lexicon of any language. It defines the relationship between predicates and their NP-arguments generated in a sentence. Theta theory is the component of the grammar that oversees the assignment of theta-roles to arguments. It only specifies the number of NPs and their type. There is also the theta criterion stated in Haegeman (1994: 46) which states as follows :

- (7) Theta criterion

(i)- Each argument is assigned one and only one theta-role;

(ii)- Each theta-role is assigned to one and only one argument.

This means that a one to one relationship obtains between the theta-role assigned by a predicate and the NP that receives it. Theta-roles are assigned at D-structure and under government.

1.3.3 CASE THEORY

This is the component of the grammar that accounts for the formal properties of overt NPs. Theta-roles determine the argument structure of a predicate and not the kind of NP that can fit in the various categories. This is the domain of case marking. Bach (1973: 100) defines case as "a system whereby the functional relation of a nominal element to a verb is indicated by a marker called a case marker which may be either an affix or a separate word associated with the nominal element". Case is assigned at S-structure and all lexical NPs must be assigned a kind of case in what has been called the case filter.

(8) Case filter

Every overt NP must be assigned abstract case

(Haegeman, 1994: 156).

This means that a sentence will be ungrammatical if there is an NP in it, which is not case-marked or is assigned the wrong case. A distinction is made between morphological case and abstract case. Morphological case assignment is when a particular case is identified by a morpheme such as '-m' in English which shows accusative case as in 'hi-m' and in 'who-m'. Abstract case is an element of Universal Grammar and has no overt morpheme that shows that case has been assigned.

A case assigner can assign only one kind of case to an NP at a time, that is, the same case cannot be assigned to two separate NPs. A single NP cannot receive two case assignments. Radford (1981: 354) sums this constraint up in what he calls the case conflict filter.

(9) Case conflict filter

No NP can carry more than one case marking.

The minimality condition applies to case marking. Hence, every maximal projection, with the exception of a tenseless IP, that is, any XP, is a governing domain and therefore a barrier for outside case marking. A head cannot case-mark an element in a maximal projection. However, some languages license the so-called exceptional case marking (ECM), according to which some heads govern into XPs and case-mark an element in them. This is always when such an NP did not have

case for want of a case assigner (as it is the case with tenseless IPs) so as to respect (9) above. This is the case with the English verb *believe* in (10) below :

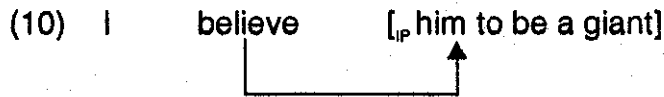

1.3.4 FOCUS PHRASE

This is postulated in Biloa (1995 : 51-89) to account for the data from Tuki. He argues that there is a phrasal constituent between CP and IP called F(ocus) P(hrase) which hosts fronted WH-elements even when the C of CP is filled by a lexical complementizer as seen in (11) below:

- (11) a. [_{CP}...ee [_{FP}ane odzu [_{AGFP}Puta a --dingam]]]
 that who FOC Puta SM love
 "...that who does Puta love ?"
 (Biloa, 1995 : 71).

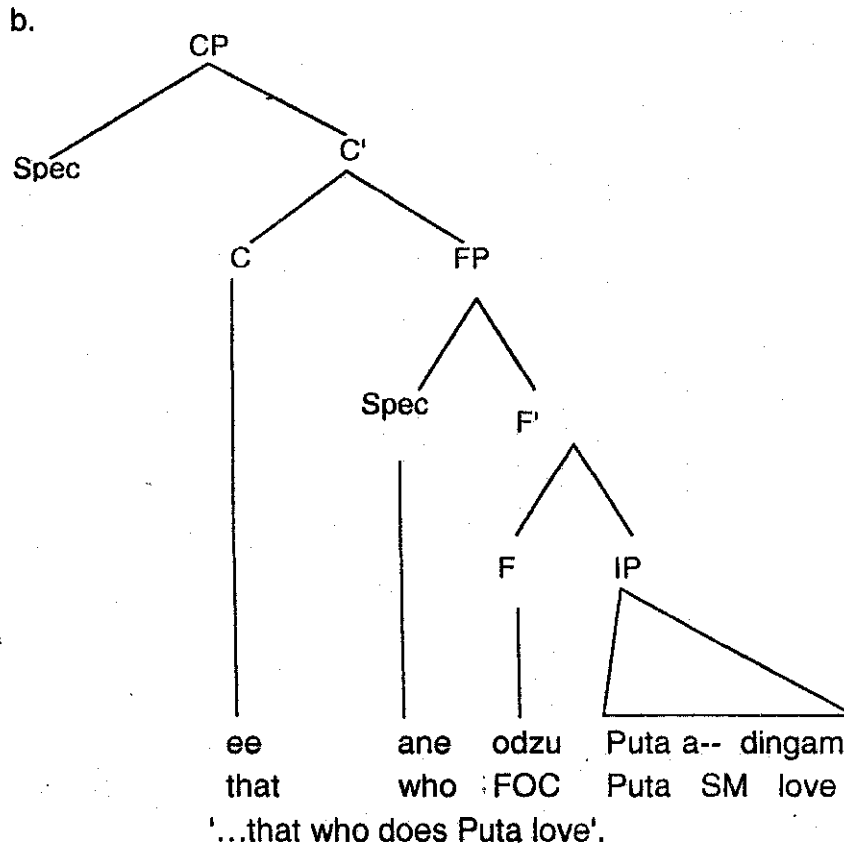

Biloa (ibid, P. 74) argues that, in spite of the morphological resemblance in FOCUS word between WH-fronting and relativisation, relative operators of fronted NPs land in spec of CP. He further argues that the so-called relative operators in

traditional grammar are Focus words in Tuki which agree in noun class with the fronted element. The Focus word is the head of FP and assigns the feature Focus to [spec, FP] under government and adjacency.

1.4 PLAN OF WORK

This work is divided into five chapters. Chapter One is the general introduction in which we introduce the work, set its objectives, state its relevance and determine its scope. In it, we also review some theories developed by linguists which will be used in the description of the data from Lamnso'. Chapter Two is the presentation of the language. In it, we make a sketch of certain processes in Lamnso' that have direct relevance to the present study. These include : the linguistic classification of Lamnso', the phonology of Lamnso', its noun class system, verbal morphology, word order and types of sentences. In Chapter Three, we introduce the data from Lamnso' and in it, we describe the processes involved in cleft constructions such as V-preposing and the occurrence of the copula. We also highlight some issues engendered by those processes. Chapter Four handles the discussion of these issues and their relation to sentence structure and to some theories postulated by linguists. Chapter Five, the general conclusion, makes a summary of the findings and shows those that are attributable to Universal Grammar and those that are parametrized.

CHAPTER TWO

PRESENTATION OF THE LANGUAGE

2.1 PRELIMINARIES

This chapter presents Lamnso' geographically and shows its linguistic classification. It also looks at some grammatical aspects of Lamnso' that are going to have a bearing on the discussion of clefting in the language. It, therefore, does not go into some details that may not have a direct effect on clefting in the language.

2.1.1 GEOGRAPHICAL SITUATION OF NSO'

Lamnso' is the language spoken by the Nso' people in the Bui division in the North West province of Cameroon. The Bui division is made up of five subdivisions out of which Lamnso' is spoken in three, namely Kumbo, Jakiri and Mbven subdivisions. According to Chem-Langhëë and Fanso (1997 : 43), the Nso' Kingdom covers an area of about 2,300 square kilometres and has a population of about 250,000 people. Below, in figure 1, is an administrative map of Cameroon which situates the Bui division within the vast territory of Cameroon. It is seen in it that the North West province is divided into divisions.

Figure 2 is the map of the Bui division showing its five subdivisions and the three in which Lamnso' is spoken as the sole, if not, the major language of communication. It also indicates the neighbouring languages to Lamnso'. According to the map, Lamnso' is bounded to the North by the Limbum language in Donga Mantum division; to the North East by Mbe and Tikari, spoken in the Nwa subdivision in Donga Mantum division; to the East, South East and South by Shupamem, the language of the Bamoun people spoken mainly in the Noun division of the Western province; to the South West by Wushi and Papiakum spoken in Ngoketunjia division; and to the North West by Kuo (Oku) and Noone respectively, spoken in the Oku and Noni subdivisions of Bui division.

Figure 1 : *Administrative map of Cameroon.*

Source : National Institute of Cartography, Yaounde

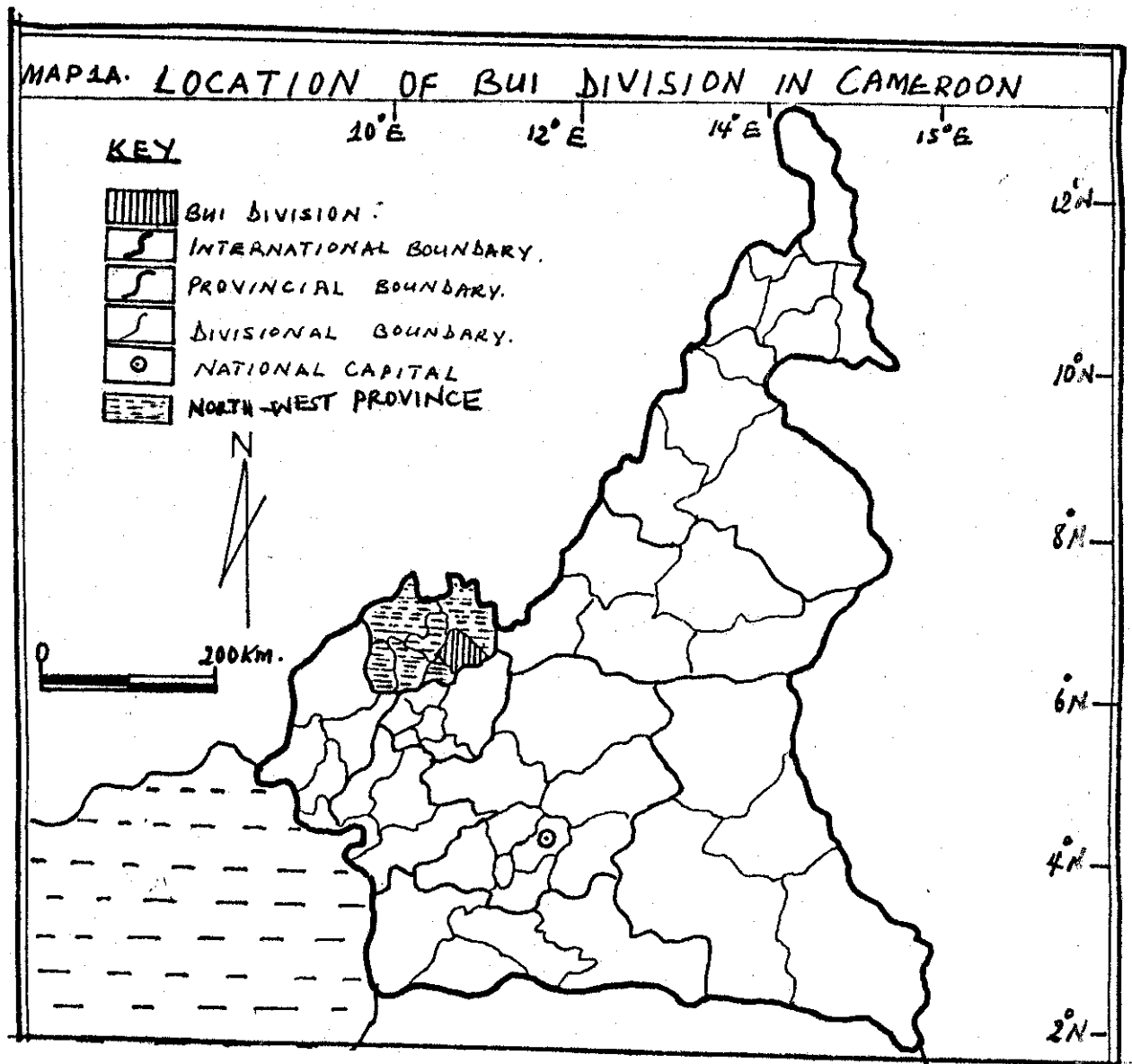
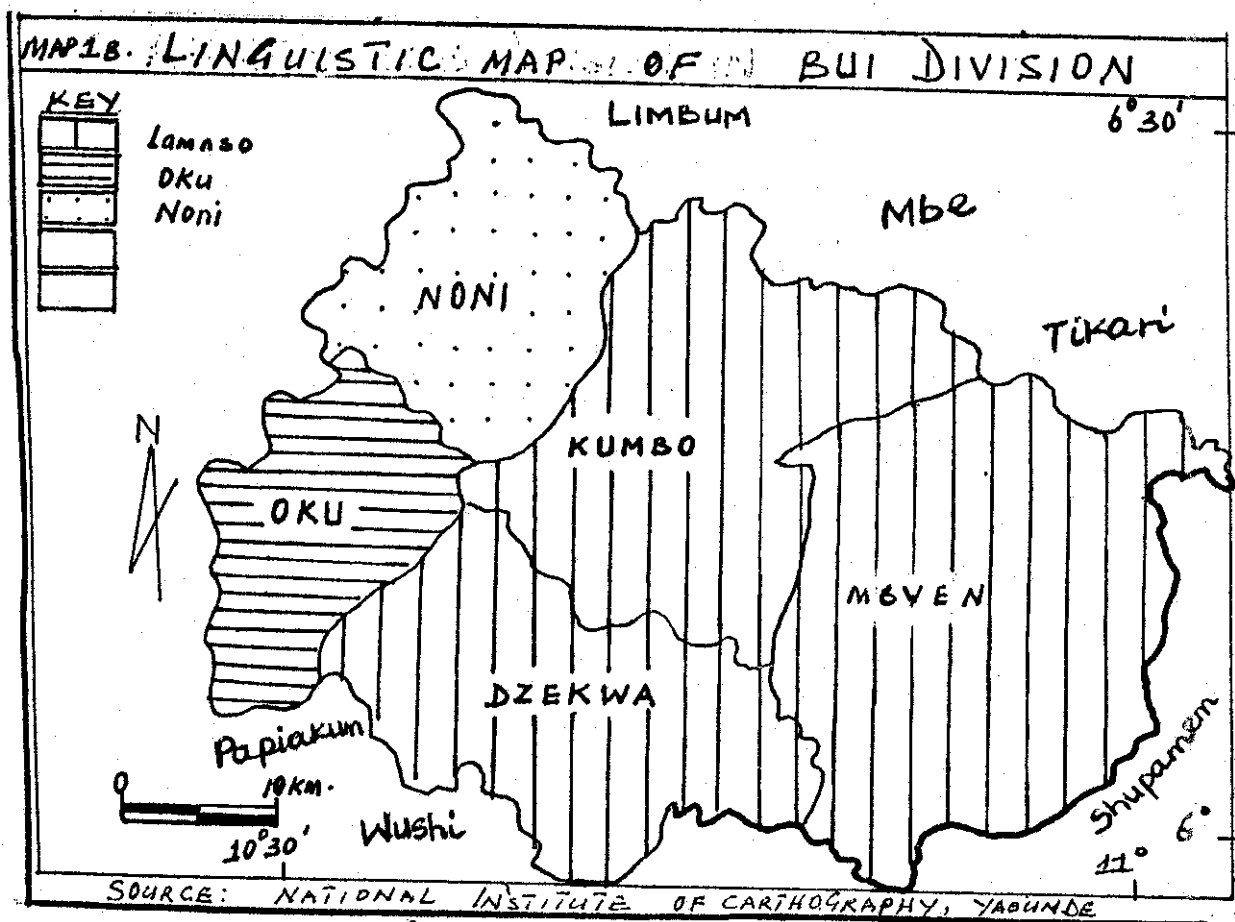

Figure II : Map of Bui Division.

Source : National Institute of Cartography, Yaounde



2.1.2 THE LINGUISTIC CLASSIFICATION OF LAMNSO'

The linguistic classification of Lamnso' ^{adopted for this study} is based on the classification of African languages by Greenberg (1996). He classified African languages from top to bottom into: phyla, sub-phyla, families, sub-families, branches, sub-branches, groups and specific languages. His classification was based on a comparative study of vocabularies that grouped African languages into affinity groups.

Although Greenberg (1996) did not mention Lamnso' in his classification, Lamnso' has been classified following his approach. The classification of Lamnso' in this work follows from the results of the preliminary inventory of the Linguistic Atlas of Cameroon (ALCAM) - a national programme involved in research on national languages. This programme, born in the University of Yaounde in 1971, set out to make an inventory and classification of all Cameroonian languages and to do research on them. In 1993, the programme identified 248 languages in Cameroon.

Lamnso is numbered 850 in ALCAM (1983) and can be traced from the Niger Kordofan phylum, to the Niger Congo sub-phylum, to the Benue Congo family, to the Bantoid subfamily, to the Western Grassfield Bantu sub branch to the East Ring group and finally to Lamnso' itself. Lamnso', according to Grebe (1984) has no dialectal variation. Figure 3 below captures the genealogical tree of Lamnso'.

Figure III : *The genealogical tree of Lamnso' based on Greenberg's classification of African languages.*

Source : Adapted from ALCAM (1983) (pp. 352, 360 and 362).

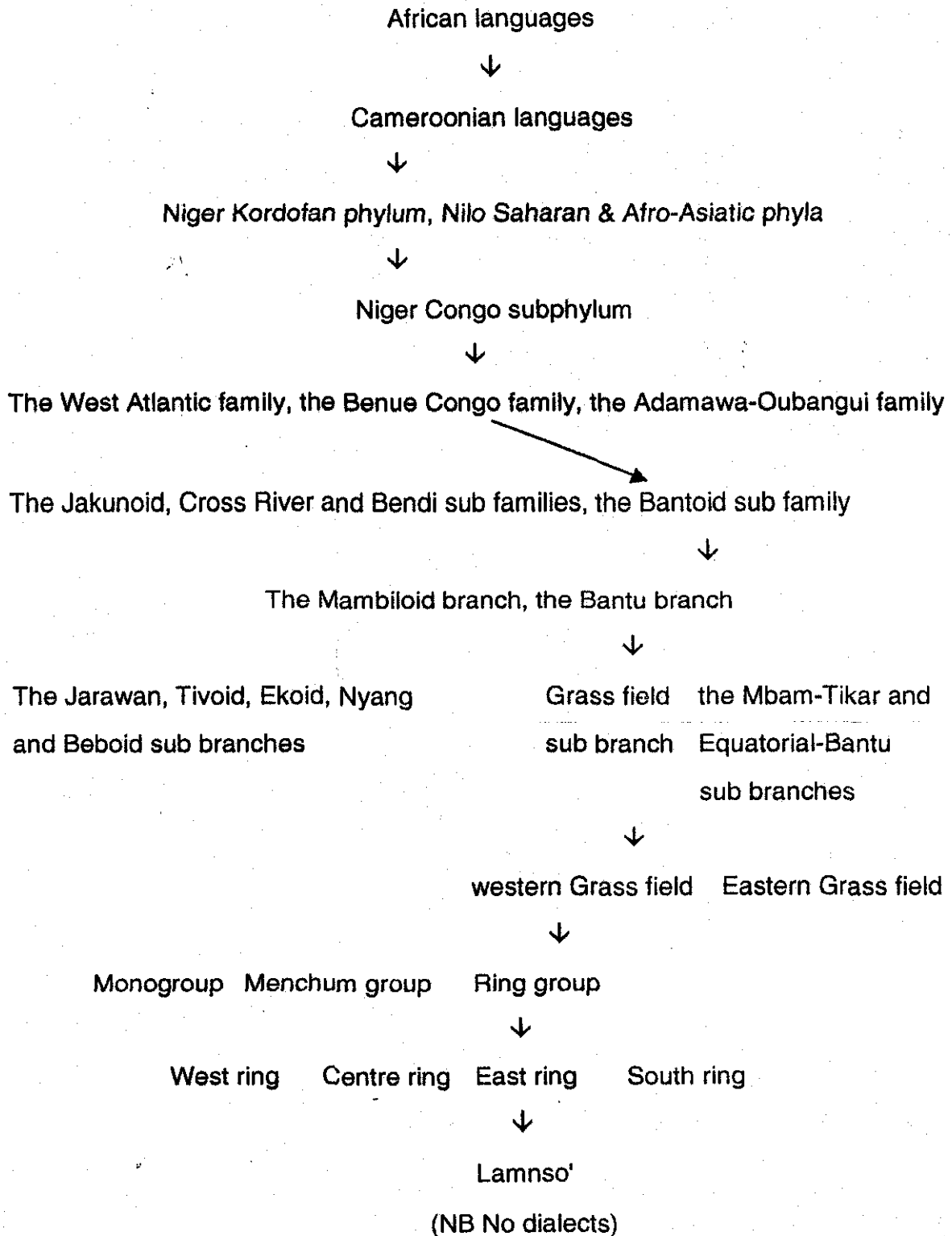

2.2 PHONOLOGY OF LAMNSO'

Some of the earliest research works on Lamso' are attributed to Grebe (1976, 1984). These works are essentially phonological works. Grebe (1976) discusses the phonological hierarchy of Lamso', ranking in descending order from the phonological utterance (made up of phonological words) to the phonological word (made up of syllables) to the syllables made up of phonemes. Grebe (1984) discusses noun tone rules. He shows how tones emanate from the nucleus syllables and spread to peripheral ones.

2.2.1 VOWEL SYSTEM

According to Grebe (1976) and (1984), Lamso' has six vowels as seen in figure 4.

Figure IV : *Lamso' vowels* (taken from Grebe, 1984 : 24).

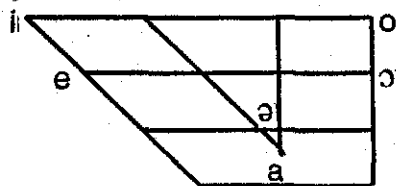

The distribution of these vowels depends on the syllable structure of the language. Grebe (1976 : 10 - 24) says that the Lamso' word is basically monosyllabic. The nucleus syllable (the main syllable) may then take peripheral syllables to the left and to the right. The V - segment of the nucleus syllable can take any other vowel as seen below :

- | | | | |
|-----|----|-------|------------------------|
| (1) | a. | shəm | "to refuse" |
| | b. | shām | "to chew" |
| | c. | shim | "to make little marks" |
| | d. | nshòm | "stripes" |
| | e. | kíŋ | "pot" |
| | f. | rəm | "smell" (verb) |

The vowels in the "onset peripheral syllables are restricted to /i/ and /e/ as seen below :

- | | | | |
|-----|----|---------|----------------|
| (2) | a. | kì-shàm | "frog" |
| | b. | kì-rəm | "smell" (noun) |
| | c. | vì-shàm | "frogs" |

Specifically you need to other syllables are affixes

This not being the forum to discuss the writing system of Lamnso', and given its readability and convenience, the system is adopted and will be used through out this work.

The distribution of consonants in Lamnso' also depends, according to Grebe (1976) on the syllable-structure of the language. "Nucleus syllables" with a CVC structure will have the onset segment filled by any consonant in the language. The coda segment will be restricted to the following consonants : /m, v, n, r, y, ŋ, ʔ/

Class II syllables, that is, the onset peripheral syllables of the word with the CVC structure like in "Kìmfèr" will have the onset segment "C" filled by /m, v, sh, k/ and the coda segment filled by /m, n ŋ/ as in (6) below :

- (6) a. kìn-tén "not well balanced"
 b. vīŋ-góm "plantains"
 c. kìm-fèr "story"

The final peripheral syllable with a CVC structure will have its onset segment filled by /m, v, t, s, n, r, y, k, ŋ, ʔ/ and the coda segment filled by /m, n, r, y/ as seen in (7) below :

- (7) a. nà-nìn "to get (oneself) up"
 b. bé-'ém "break"
 c. bīŋ-kìr "turn round"
 d. tìn-rí "cut into pieces"

2.3 VERBAL MORPHOLOGY

Tense is indissociable from the tone system in Lamnso' because most of the tenses are marked by a modification of the tone on the verb. This could be explained by the fact that certain tenses have their grammatical morphemes or auxiliaries erased and the tone remains floating and consequently affects the tone on the verb. Lamnso' has three tones : high (´), mid (-) and low (˘). These tones can combine to form contours such as low-high (v) and high-low (^). The basic tones of the language are shown in the following infinitival forms :

- (8) a. fô lim "to work"
 b. fô yī "to eat"
 c. fô bé' "to break"

3 questions

"F0" is the infinitive marker. It will be seen below that the various tenses are marked by the modification of the tones on the verbs.

2.3.1 SOME VERBAL TONEMES AND MORPHEMES

2.3.1.1 The Present Progressive Tense

There is a high floating tone that forms contours with the tones on the verbs. High-L Low becomes low-high, high remains high and mid becomes mid-high as seen below:

- (9) a. Chin lim sum
 H L H
 Chin work farm
 "Chin is working on the farm"
- b. Chin lim sum
 H L H
 Chin work farm
 "Chin is working on the farm"
- c. Chin lim sum
 H L H
 Chin work farm
 "Chin is working on the farm"
- d. Chin bé' kici
 break stick
 "Chin is breaking a stick"

On previous page you say tens morphemes are erased (you should say deleted/dropped and the tones of these deleted morphemes affect tones on verbs. Is the tense morpheme to the right what do you consider to be the underlying position of the tense morpheme to the right or left of verb? what does illustrate? see sentence immediate above.

2
 What does (d) illustrate?

5
 Explain
 as if in conjugate phrases

It is also necessary to note that tenses in Lamnso' take only one conjugated form because there is no subject verb agreement as seen in (10) below :

- (10) a. m lim sum
 I work farm
 "I am working on the farm"
- b. à lim sum
 you work farm
 "you are working on the farm"
- c. wù lim sum
 He work farm
 "he is working on the farm"
- d. vèr lim sum
 we work farm
 "we are working on the farm"
- e. vèn lim sum
 you work farm
 "you are working on the farm"
- f. áwúní lim sum
 they work farm
 "they are working on the farm"

2.3.1.2 The Present Tense

This is marked by the habitual morpheme "yí" plus the tone of the verb in the present progressive form.

- (11) Chin yíŋ lím súm
 Chin habitual marker work farm
 "Chin works on the farm"

2.3.1.3 The Past Tense

This is marked by a morpheme with a high tone. This morpheme can either be the lengthening of the final vowel of the subject (if the subject ends in a vowel) or the addition of /i/ on the subject (if it ends in a consonant). In both cases, the morpheme carries a high tone. It is the case that this high tone spreads to the verb and the original tone of the verb delinks, especially if we compare (12) below with (9) above :

- (12) a. Chin-í lím súm
 Chin PT work farm
 "Chin worked on the farm"
- b. píŋà-á lím súm
 Peter PT work farm
 "Peter worked on the farm"
- c. Chin - i lim sum
 | | |
 H L H
- d. Chin - i lim sum
 | | |
 H L H
- e. Chin - i lim sum
 | | |
 H L H
- f. Chin - i lim sum
 | | |
 H L H
- g. Chin - í lím súm

(12 c) - (g) above show the derivation of (12 a).

2.3.1.4 The Future Tense

It is marked by the future marker "yíŋ" plus the verb in its infinitive form.

- (13) Chin yíŋ lím súm
 Chin FUT work farm
 "Chin will work on the farm"

2.3.1.5 The Present Perfect Tense

It is marked by the downstepping of the infinitive tone on the verb to a low tone. The low tone cannot go further down.

- (14) a. Chin lim súm
Chin work farm
"Chin has worked on the farm"
- b. Chin yi kibán
Chin eat fufu
"Chin has eaten fufu"

2.3.1.6 The Future Progressive

In addition to the future tense in 2.3.1.4 above, this tense is marked by the insertion of an additional morpheme "á" after "yíí" as seen below :

- (15) a. Chin yíí á lim súm
Chin FUT work farm
"Chin will be working on the farm"
- b. Chin yíí á yi kibán
Chin FUT eat fufu
"Chin will be eating fufu"

2.3.2 SOME VERBAL EXTENSIONS

P.C. It has already been seen that "final peripheral syllables" play a grammatical role in Lamnso' by marking aspect. Grebe (1984 : 40) provides the following verb structure :

- (16) root stem
suffix 1 suffix 2
C V (V) (C) + (C) V (c) # V (c)
-kir
-nin
-ti
-ri
-si
-sin
-tir
-im
-ir
-iy

Accordingly, a verb like *mày* "to finish" will have the following forms :

- (17) a. *mày* "finish" (intransitive)
b. *mày-kìr* "finish" (distributive)
c. *mày-kìr-ì* "finish" (perfective)

	-láj	"pot"	à-láj	"pots"
	-wíy	"woman"	vì-kíy	"women"
	-lúmìn	"man"	vì-lúm	"men"
b.	class 3		class 10	
	-táv	"hut"	táv-sí	"huts"
c.	CL 5		CL 10	
	-tén	"palm tree"	tén-sí	"palm trees"
d.	CL 9		CL 10	
	-lāv	"house"	lāv-si	"houses"
	vīn	"breast"	vīn-si	"breasts"
e.	CL 7		CL 8	
	-kitú	"head"	vitú	"heads"
f.	CL 19		CL 6 (a)	
	-shishúr	"pepper"	mìshúr	"peppers"

The notion of overt and covert noun class affixes is crucial in the syntax of Lamnso'. This concerns, particularly, the subject marker position. Only overtly noun-class-marked nouns take a subject marker. In other words, covertly noun-class-marked nouns do not take subject markers. The node in a sentence is, therefore, realised as \emptyset as seen below :

- (21) a. kimbàj kì yí kìbán
whiteman SM eat fufu
"The whiteman is eating fufu"
- b. Chin \emptyset yí kìbán
Chin SM eat fufu
"Chin is eating fufu"

2.5 WORD - ORDER OF LAMNSO'

Consider the following sentences :

- (22) a. Chin wíy ì
Chin come
"Chin is coming"
- b. Chin yí kìbán
Chin eat fufu
"Chin is eating fufu"
- c. Chin fó kìbán í Bih
Chin give fufu to Bih
"Chin is giving fufu to Bih"

poor introduction.
On next page you say
when a copulative suffix is
added, the arguments
of the verb
are no explicit
explanation?

- d. Chin fó Bih kìbán
Chin give Bih fufu
"Chin is giving Bih fufu"
- e. Chin bâ
Chin mad
"Chin is mad"
- f. Chin bá-ár won
Chin mad-CAUS children
"Chin made the children to be mad"

(22) shows that Lamnso' is an S V O language and that, in (22a) one place predicates exist. (22b) shows that two place predicates also exist. (22c) and (22d) show that three place predicates are also in the language. (22) shows that, when the form of a verb is modified by a causative suffix, the argument structure is altered. These rules will be formalized as shown below :

- (23) S → NP VP
NP → N
VP → {V (NP) (NP)
(PP)}
PP → P NP

It is also necessary to look at phrasal constituents more closely.

2.5.1 THE SUBJECT NP

Consider the following sentences :

- (24) a. Chin Ø yí kìbán
Chin SM eat fufu
"Chin is eating fufu"
- b. kimbàŋ kí yí kìbán
whiteman SM eat fufu
"The whiteman is eating fufu"
- c. kimbàŋ kiy kí yí kìbán
whiteman that SM eat fufu
"That whiteman is eating fufu"
- d. vimbàŋ vibàà ví yí kìbán
white man two SM eat fufu
"Two whitemen are eating fufu"
- e. [_{NP}kimbàŋ, kè [_Pkíí wiyín fén]]kí yí kìbán
white man that he come here SM eat fufu
"The whiteman, who [_Pcame here] is eating fufu"

You are explaining the mechanism in the resumptive pronoun. With your (read sentence) (acknowledged). Why does the noun need for government 23. It's normal that normally government the subject position? With the same resumptive pronoun. (24c) and (24d) show that [NP → N det.]. (24e) shows that resumptive pronouns exist in the language. It may be the case that the lexical complementiser, *ké* in (24e) prevents the moved NP from properly governing (through antecedent government) its trace. (24a) and (24b) show that there is a phrasal head between the subject NP and the VP, and that its overt realisation depends on whether the noun class has an overt noun class marker. This element is the head of Agreement Phrase since it comes as the result of agreement with the noun class of the subject NP. *what is a phrasal head?*

2.5.2 THE VERB PHRASE

2.5.2.1 Constituents Left of the VP

Immediately to the left of the verb is the tense morpheme (if it exists) which cannot be separated from the verb by another constituent as seen in (25) below :

- (25) a. Chin yí lim súm
 Chin FUT work farm
 "Chin will work on the farm"
- b. *Chin yí yò' lim súm
 Chin FUT NEG work farm
 "Chin will not work on the farm"

The ungrammaticality of (25b) is explained by the fact that a constituent separates the tense morpheme from its verb. This could be construed as the violation of the adjacency requirement between the verb and its tense morpheme. Such a requirement will state as follows :

(26) A tense morpheme must be adjacent to the left of the verb.

This requirement is crucial for this study for it will be shown in the next chapter that verb movement is accompanied by INFL.

Another leftward constituent to the VP is the negative marker (NEG) which precedes the tense morpheme as shown below :

- (27) Chin yò' yí lim súm
 Chin NEG FUT work farm
 "Chin will not work on the farm"

One other constituent that comes to the left of the VP is "sà" (whether). It is necessary to note that "whether" in Lamnso' is realised through the following formula:

- (28) [_{IP}... [_{CP} dzi [_{IP}... sà... [_{VP} V...]]] á]

(28) shows that it is the combination of "dzi" (that) and "sà" in the embedded clause that is equivalent to the English "whether". (29) below shows that, between "yò" (not) and "sà", it does not matter which one comes first.

- (29) a. ... dzi Chin yò' sà kónj Bih á
 that Chin NEG whether love Bih Qm
 "whether Chin does not love Bih"
- b. ... dzi Chin sà yò' kónj Bih á
 that Chin whether not love Bih Qm
 "whether Chin does not love Bih"

2.5.2.2 Constituents to the Right of VP

As seen above and repeated here for convenience' sake as (30), the VP has the following structural description :

- (30) VP → {V (NP) (NP)
 (PP)}

Other rightward VP- constituents are non - V - complements such as adjuncts of time, of place and of manner as seen below :

- (31) a. Chin fó kibán í Bìy lán
 Chin give fufu to Bih today
 "Chin is giving fufu to Bih today"
- b. Chin fó kibán í Bìy í ntó
 Chin give fufu to Bih at palace
 "Chin is giving fufu to Bih at the palace"
- c. Chin fó kibán í Bìy lán í ntó
 "Chin is giving fufu to Bih today at the palace"
- d. Chin yí kibán cércér
 Chin eat fufu fast fast
 "Chin is eating fufu very fast"

Other adverbs such as "kìn" and "tàmbo" which mean "perhaps" and "maybe" come at sentence initial position as seen in (32).

- (32) a. kìn Chin wíyí
 perhaps Chin come
 "perhaps Chin is coming"
- b. tàmbo Chin wíyí
 perhaps Chin come
 "perhaps Chin is coming"

2.5.3 OBJECT NPs

One peculiar thing about object NPs in Lamnso' is that the language has not got object pronouns for NPs with the feature [+ accusative, - animate] as seen below :

- (33) a. Chin yí kibán
Chin eat fufu
"Chin is eating fufu"
- b. Chin yí ø(pro)
Chin eat
"Chin is eating it"
- c. Chin kōŋ Bih
Chin love Bih
"Chin loves Bih"
- d. Chin kōŋ wùn
Chin love her
"Chin loves her"

The empty space in (33b) is recovered by context.

Figure 7 below shows personal pronouns in the language and their nominative and objective forms.

Figure VII : Lamnso' personal pronouns.

Nominative		Objective	
m	I	mó	me
à	you	wò	you
wù	he / she	wùn	him / her
kí, shí, yí, sí etc	it	ø	it
vèr	we	vèr	us
vèn	you	vèn	you
áwúní	they	áwúní	them

Unlike subject NPs, object NPs do not have resumptive pronouns copied into spaces vacated by them as seen in (34) below :

- (34) a. Chin kōŋ Bih

- Chin love Bih
 "Chin loves Bih"
- b. Biy wó Chin kōŋi____
 Bih that Chin love
 "Bih that Chin loves"

2.5.4 THE PP

The main prepositions in Lamnso' are / which means either "to", "at", "in" or "on" and fó which means "from". Prepositions can assign dative, genitive, locative and instrumental case as seen below :

- (35) a. Chin fó kibán í Bih
 Chin give fufu to Bih
 "Chin is giving fufu to Bih" (dative case)
- b. kibán ké Chin
 fufu of Chin
 "Chin's fufu" (genitive case)
- c. Chin dū í shì kúr
 Chin go to school
 "Chin is going to school" (locative case)
- d. Chin wiy fó shì kúr
 Chin come from school
 "Chin is coming from school" (locative case)
- e. Chin yí kibán í shìbún shí
 Chin eat fufu at spoon INSTR. Marker
 "Chin is eating fufu with a spoon" (instrumental case)

In (35e), it is the combination of the preposition / and the noun class agreement after the noun that shows that the noun is being assigned instrumental case. Unlike in English, Lamnso' prepositions do not assign agentive case. Hence, "by - phrases" do not exist in the language. This may partially explain why NP-movement processes such as passivisation are impossible in the language. It will be shown in the next chapter that one of the uses of clefting in Lamnso' is to replace passivisation (a kind of paraphrasing).

When NPs are extracted from PPs, resumptive pronouns come in to fill the traces as seen below :

- (36) a. *Bih wó Chin fó kibán í
 Bih that Chin give fufu to
 "Bih whom Chin is giving fufu to"

Where are the resumptive pronouns?

I do not see these illustrations in the first 2 examples. There is the next phrase you say

is 36 meant to illustrate? What does this mean? I don't understand.

- b. Bih í wō Chin fó kibán
 Bih to that Chin give fufu
 "Bih of whom Chin is giving fufu"
- c. Bih wó Chin fó kibán (shó)
 Chin that Chin give fufu Resumptive Pronoun
 "Bih to whom Chin is giving fufu"
- d. shé Chin yí kibán shó
 spoon that Chin eat fufu Resumptive Pronoun
 "The spoon with which Chin is eating fufu"
- e. shikúr shé Chin wíy fó fó
 school that Chin come from Resumptive Pronoun
 "The school from which Chin is coming" 30

The ungrammaticality of (36a) and (36b) show that both preposition stranding and pied-piping are impossible processes in the language. (36e), which is a transformation of (35d), clearly shows an example of a resumptive pronoun. As it will be seen below, *sh-ò* is made up of two morphemes. "sh_" which replaces "í" and "ò" the resumptive pronoun proper.

- (37) a. làv yé Chin dzé í bàm o
 house that chin sit at behind resumptive pronoun
 "The house behind which Chin is sitting"
- b. bàm làv wō Chin dzé sho
 back house that Chin sit Resumptive Pronoun
 "The back of the house where Chin is sitting"

It is, therefore, clear that the deletion of "í" is recoverable through "sh". Hence, it is "ó" that is the resumptive pronoun.

2.6 SENTENCE TYPES

2.6.1 DECLARATIVE SENTENCES

It has been seen in 2.5 that Lamnso' is an SVO language and that the structure of its kernel sentences will read like (37).

- (37) a. S → NP AGRP
 b. AGRP → AGR VP
 c. NP → N (S)
 (Det)
 d. VP → V (NP) (NP)
 (PP)
 e. PP → P NP

2.6.2 INTERROGATIVE SENTENCES

2.6.2.1 Yes / No Questions

This question type is formed by adding a question marker "à" at the end of a declarative sentence. It should be noted that "à" here has a low tone and is different from the "á" of (28) and (29) which is that of an indirect question and has a high tone.

- (39) a. Chin kónj Bih à
Chin love Bih QM
"Does Chin love Bih?"
- b. Chin yí kibán à
Chin eat fufu QM
"Is Chin eating fufu?"

2.6.2.2 WH - Questions

Lamnso' has got about six WH-question words that are used as shown below :

- (40) a. ká (things) "what"
b. lá (persons) "who"
c. fě (place) "where"
d. lé (manner) "how"
e. ghànká (time) "when" (what time)
f. kíní, víní, síní, etc "which" (depending on the noun class of the noun in question).

These question words can remain ^{*in situ*} at base, that is, be echo questions as seen below :

- (41) a. Chin kónj lá
Chin love who
"Chin loves who?"
- b. Chin yí ká
Chin eat what
"Chin is eating what?"

Unlike in English, when question words move to COMP, another transformation inserts a copula "dzè" before them without which the sentence is ungrammatical as seen below :

- (42) a. *lá wó Chin kônj
Who that Chin love
"who does Chin love?"

- b. dze lá wó Chin kôŋi
 is who that Chin loves
 "who does Chin love?"

It should also be noted that, unlike in English, when a WH - phrase lands in [spec,CP], the complementiser "that" fills the head position, C.

2.6.3 EMBEDDED SENTENCES

In Lamso', only tensed IPs can be embedded, that is, verbs do not take infinitival clauses as complements, save for the case of Equi - NP - Deletion. The embedded clauses are that (dzi)-clauses and take two forms : declarative (with only "dzi") and interrogative (with "dzi" and "sà" following the formula in (28))

- (43) a. Chin tâ' fô lîm sùm
 Chin want to work farm
 "Chin wants to work on the farm"
- b. *Chin tâ' Bîy (fô) lîm sùm
 Chin want Bih to work farm
 "Chin wants Bih to work on the farm"
- c. Chin tâ' dzi Bîy lîm sùm
 Chin want that Bih work farm
 "Chin wants that Bih should work on the farm"
- d. Chin dzér dzi Bih sà lîm sùm á
 Chin ask that Bih whether work farm QM
 "Chin is asking whether Bih is working on the farm"

(43a) shows that an infinitival clause can be the complement of a verb iff its subject is equal to that of the verb in the matrix clause. This is buttressed by the ungrammaticality of (43b). (43c) shows that, otherwise (when the subjects of two clauses are different), only that-complements are permitted. (43d) is the case of an embedded clause that is interrogative. Embedding in Lamso' can be formalized as follows :

- (44) an IP with the feature [-tense] cannot be embedded nor take a subject NP unless such an NP is a null element (PRO) controlled by or co-indexed with another NP in [spec, IP] of its matrix clause.

2.7 SUMMARY

In this chapter, we have seen that, at the level of auto segmental phonology, when a segment disappears in Lamnso', its tone affects the tone of neighbouring words. This notion has helped us in the analyses of verbal morphology in the language. We have seen that, apart from few cases where morphemes actually exist, tense in the language is marked by ^{tones.} tonal modifications, we have also seen that the notion of covert and overt noun class markers is important in the language because the AGRP depends on it for its overt realisation. We have also established some rules of the base component in Lamnso' and have concluded that Lamnso' is an SVO language as well as have examined constituents to the left and right of the verb and their ordering. We have also looked at some T-rules in the language under which we discovered that resumptive pronouns exist in Lamnso' when elements are extracted from certain categories such as subject NPs and PPs; that preposition stranding and piedpiping are, therefore, impossible in the language; and that object pronouns for inanimate direct objects do not exist. We have also seen how, from declarative sentences, questioning and embedding are achieved. The next chapter looks at the way clefting is achieved in Lamnso' and the novel concepts that are needed to talk about it and how they could be analysed.

CHAPTER THREE

V- PREPOSING AND COPULA INSERTION

INTRODUCTION

The aim of this chapter is to provide an observationally adequate analysis of the Lamnso' data in relation to clefting. Its focus is to bring out those processes and novel concepts that are involved in clefting in the language. It, therefore, examines what happens to subject NPs, to object NPs, to PPs, to AGRPs and to adjuncts when they are given focus prominence in the language. It is divided into two sections. Section one deals with V-preposing, its uses, preposable verbs and the effect of verb movement on other constituents that surround the verb. Section two looks at copula-insertion and its uses. It also examines the expletive *-a* that occurs at base and its deletion in sentence initial position.

Riemsdijk and Williams (1986 : 102) provide the following formula in (1a) for clefting in English that will yield the sentence in (1b) :

- (1) a. It be NP S'
 b. It is John, that I like e,

Explain
 IS John wh
 T.P.O.

(1b) shows that to put a constituent in focus position involves *move - wh*. This chapter shows that cleft constructions in Lamnso' have some similarities to as well as some parametric variations with English and some Bantu languages of the Grassfield region as captured in (2) below :

- (2) a. Similarities :
- (i) it may involve move alpha and
 - (ii) for a constituent to be put in focus, it needs that a verb comes before it.
- b. Parametric variations concern the following domains :
- (i) the origin of the verb that precedes the focus constituent,
 - (ii) Where the verb moves to,
 - (iii) The structure of the clause after v-movement, and
 - (iv) The structural requirement that deletes the expletive in sentence initial position.

3.1 V-PREPOSING

3.1.1 THE USE OF V-PREPOSING

Movement of the verb to sentence initial position in many languages such as vata (Koopman, 1984) and Tuki (Biloa, 1995) has been linked to predicate clefting in which the verb is given focus. In Lamnso', V-movement does not place the verb in focus position but gives the elements it precedes focus prominence [see (7b) below]. Another use of V-preposing in Lamnso' consists in paraphrasing passive constructions in a language where passivisation is virtually absent. The language has not got passive verbs as in English or passive morphemes as in some African languages. We have also seen in Chapter Two that by-phrases do not exist in Lamnso' since a preposition cannot assign agentive case. The nearest translation of or substitute for an English passive construction is the cleft construction as demonstrated below in (4) with the sentence in (3):

- (3) Mary is loved (by John)
- (4) a. John kôŋ a dze Mary
John love it is Mary
'It is Mary that John loves'
- b. dzè Mary wo John kôŋj
is Mary that John love
'It is the Mary that John loves'

What is a passive verb?
You are
intransitive
Agentive case structure
of English or
Lamnso'?

If the normal order of agentive is adjusted to give it terminal weight (Quirk and Greenbaum, 1979 : 411) as in the English sentences below :

- (5) a. Who makes these chairs ?
b. They are made by JOHN.

then in Lamnso', this is done either by preposing the verb or by inserting the copula (see section 3.3 below) in front of the relevant element.

As it will be seen later on, V-preposing typically concerns subject NPs. The verb of the sentence is preposed to the left of the subject NP following the formula in (6) :

- (6) NP ___ AGRP ___ V ___ NP → V ___ NP ___ NP

(7) and (8) below provide examples that fit in the frame in (6). The focused word is indicated by capital letters.

(7) a. kimbáŋ kí ø kôŋ Bih
whiteman SM TNS love Bih
'The whiteman loves Bih'

b. kôŋ KIMBAN Bih
↑

love whiteman Bih
'It is the whiteman who loves Bih'

(8) a. Chin ø ø kôŋ Bih
Chin AGR TNS love Bih
'Chin loves Bih'

b. Kôŋ CHIN Bih
↑

love Chin Bih
'It is Chin that loves Bih'

In the (b)-examples in (7) and (6), the verb has been put in front of the subject NP to give it focus prominence, as seen from the fact that the NPs are written in capital letters. Another proof is that, if (8b) had to be turned into a question by replacing *KIMBAN* 'whiteman' by a question word *lá* 'who' and if one word were needed to answer such a question, it will be *kimbáŋ* as seen in (9) below :

(9) a. kôŋ lá ___ Bih
love who Bih
'who loves Bih'
or 'it is who that loves Bih'

b. kimbáŋ
'The whiteman'

V-preposing may be explained by the fact that a verb is within reach (it will be shown in 3.2 below that when a verb is not within reach, other processes apply) and the verb moves from its base position to sentence initial position, a position which is out of its governing domain. This is meant to satisfy a requirement in the language whereby a verb must come before a constituent in order to put that constituent in focus. This requirement is captured, in the meantime, by the following formula for cleft construction in Lamnso':

(10) V [AGRP NP ___ (NP)]
↑

(10) shows that V-preposing is basically a local transformation because the moved verb must be adjacent to the subject NP it puts into focus. Hence, a preposed verb cannot go very far, that is a verb in a subordinate clause cannot put an NP in subject position in the main clause in focus nor can *kôŋ* focus semantically *kimbán* in (11b) as shown below :

- (11) a. [AGRP Peter ta' [CP dzi [AGRP kimbán ki kôŋ Bih]]]
 Peter want that whiteman SM love Bih
 'Peter wants that the whiteman should love Bih'
- b. *Kôŋ [AGRP Peter ta' [CP dzi [AGRP kimbán] Bih]]
 love Peter want that whiteman Bih
-

3.1.2 PREPOSABLE VERBS

There is no restriction on verbs that may be preposed in Lamnso'. Hence, all verbs are preposable in the language as seen below :

(12) i) The copula

- a. Chin dze kimbán
 Chin is white man
 'Chin is a white man'
- b. dze Chin ___ kimbán
 is Chin white man
 'It is Chin that is a white man'

ii) One - argument verbs

- a. Chin wíyi
 Chin come
 'Chin is coming'
- b. Wíy Chin ___
 Come Chin
 'It is Chin that is coming'

iii) Two - argument verbs

- a. Chin yi kibán
 Chin eat fufu
 'Chin is eating fufu'
- b. yi Chin ___ kibán
 eat Chin fufu
 "It is Chin that is eating fufu"

Always highlight the focused constituent.

- iv) Three - argument verbs
- a. Chin fó Bih kibán
 Chin give Bih fufu
 'Chin is giving Bih fufu'
- b. fó Chin ___ Bih kibán
 give Chin Bih fufu
 'It is Chin who is giving Bih fufu'

3.1.3 ACCOMPANYING CONSTITUENTS

V- preposing is head - movement, that is, the head of VP moves and leaves behind all the constituents that it precedes, that is, complements to the right of the verb. We can, therefore, conclude that all rightward constituents (NPs and adjuncts) of the VP (the maximal projection of V) are not involved in the movement.

- (13) a. Chin [_{VP} fó kibán (Bih lān)_{VP}
 Chin give fufu to Bih today
 'Chin is giving fufu to Bih today'
- b. * [_{VP} fó kibán i Bih lān] Chin [_{VP} _____]
 give fufu to Bih today Chin
 '*Giving the fufu to Bih today is Chin'

The ungrammaticality of (13b) shows that the verb cannot move with its components or other constituents that come after it. Hence, VP-fronting is impossible in Lamnso'.

One interesting thing about V-preposing in Lamnso' is that the verb moves with all sentence constituents (maximal projections) to its left except the NP as seen below (it will be seen later on that INFL is exploded in Lamnso' such that AGR and TNS are heads of distinct phrases) :

- (14) a. Chin ø yíí fó Bih kibán lān
 Chin SM FUT give Bih fufu today
 'Chin will give Bih fufu today'
- b. yíí fó Chin _____ Bih kibán lān
 FUT give Chin Bih fufu today
 'It is Chin that will give Bih fufu today'
- c. * fó Chin ø yíí _____ Bih kibán lān
 give Chin SM FUT Bih fufu today

- (15) a. kimbán kí yíí fó kibán í Bih
 white man SM FUT give fufu to Bih
 'The white man will give fufu to Bih'.
- b. yíí fó kimbán ____ kibán í Bih
 FUT give white man fufu to Bih
 'It is the white man that will give fufu to Bih'.

In (14b) above, *yíí fó* 'will give' has moved to sentence-initial position. This shows that the TP moves obligatorily with the verb as seen in the ungrammaticality of (14c) where TNS is left behind. Notice that in (15b), the subject marker or AGR does not move with the verb and tense. Rather, it disappears (in chapter 4, we explain why it disappears). TP should contain VP (VNP)

The negative phrase also accompanies the moved verb. Consider the sentences in (16) below :

- (16) a. kimbán kí yo' yíí fó kibán í Bih
 white man AGR NEG FUT give fufu to Bih
 'The white man will not give fufu to Bih'.
- b. yo' yíí fó kimbán ____ kibán í Bih
 NEG FUT give white man fufu to Bih
 'It is not the white man that will give fufu to Bih'.

It is, therefore, clear, from (16a) above that in Lamnso', there are a NEGP and a TP between the subject NP and the VP as shown in the phrase marker in (17) below : 79

(17)

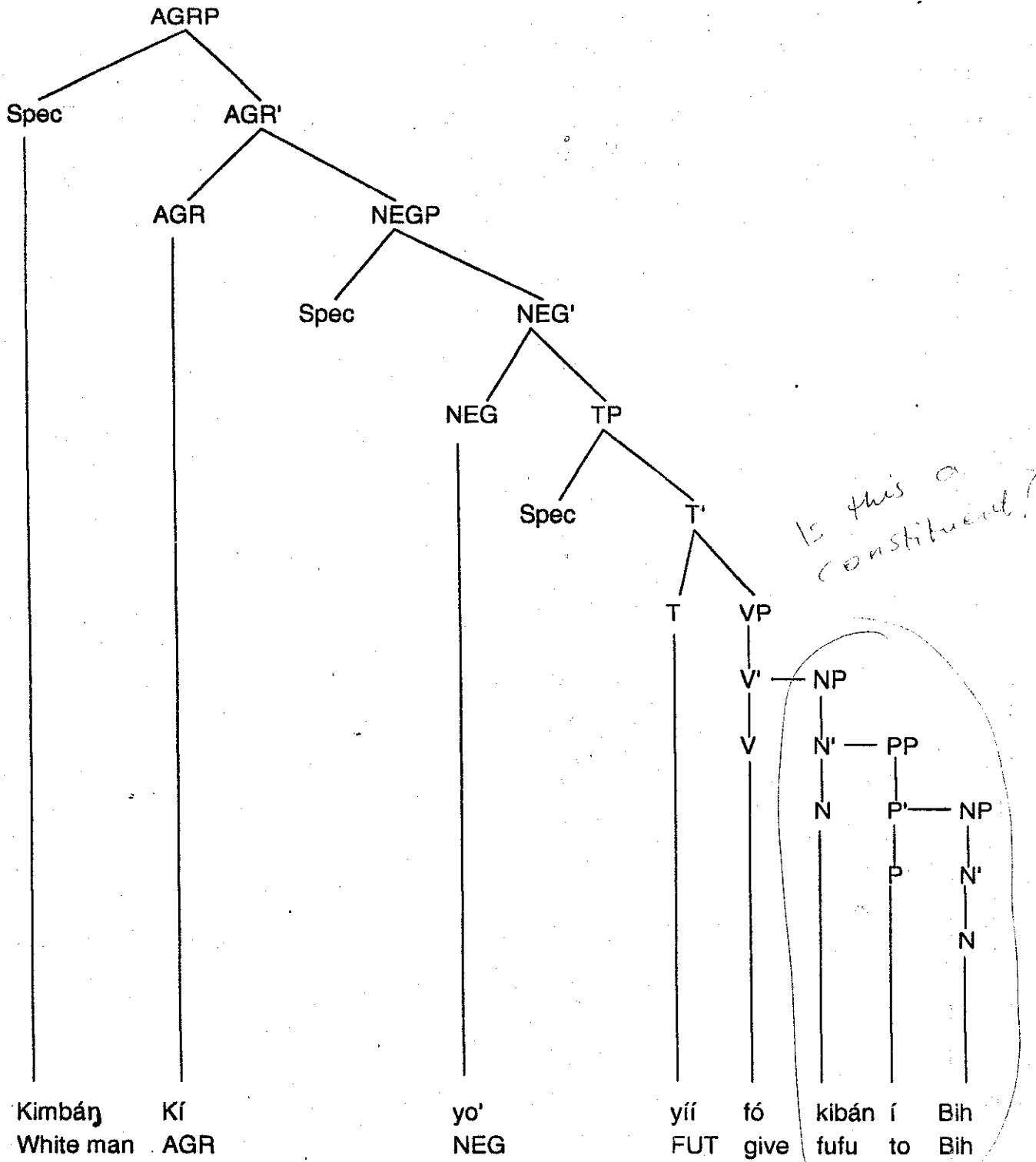

'The white man will not give fufu to Bih'.

The above representation is in accordance with the principle of the exploded INFL node as proposed by Pollock (1989) and Haegeman (1994). The generation of

yíí under the T-node provides the tense of the verb. Equally, the generation of *yo'* under the NEG-node renders the sentence a negative one.

Another element that moves with the verb is *sa*, the whether-particle. Consider the sentences in (18) below :

- (18) a. m dzer dzí Chin sa yo' yíí fó Bih kibán á
 I ask that Chin whether NEG FUT give Bih fufu QM
 'I am asking whether Chin will not give Bih fufu'.
- b. m dzer dzí Chin yo' sa yíí fó Bih kibán á
 I ask that Chin NEG whether FUT give Bih fufu QM
 'I am asking whether Chin will not give Bih fufu'.
- c. m dzer [_{CP}dzí [sa yo' yíí fo] Chin ___ Bih kibán á]

 I ask that whether NEG FUT give Chin Bih fufu QM
 'I am asking whether it is not Chin that will give Bih fufu'.

In (18a), *sa*, the whether-particle, comes before *yo'* the negation marker. But in (18b), *sa* comes after *yo'* without any change in meaning. This shows that it does not matter whether *sa* comes before or after *yo'* in a sentence. (18c) shows that *sa* equally moves with the verb. Note that *sa* can occur without the negation marker as seen in (19) below :

- (19) m dzer dzi Chin sa yíí koŋ Bih á
 I ask that Chin whether FUT love Bih QM
 'I am asking whether Chin will love Bih'.

The questions arising from (18) above are : what is the status of *sa* and where is it generated in a sentence. Is *sa* a head? First consider the formula for embedding an indirect interrogative sentence that captures (18a) and (18b).

- (20) Formula for embedding indirect interrogative clauses

[_{AGRFP} ... [_{CP}dzi ... sa ... á]]

The formula in (20) shows that, as seen in (18a) and (18b), it is the combination of *dzí* 'that', *sa*, the whether-particle, and *á*, the question marker that yields the so-called 'whether' in English. This means that *sa* is syntactically bound to the lexical complementizer *dzí* 'that'. It is, therefore, an obligatory particle generated in the embedded clause of indirect interrogative clauses when verbs like *dzer*, 'ask'

and *gha* 'wonder' subcategorize for it. *Sa* is, consequently, not a head. Given its changing position as seen in (18a) and (18b), we may not prescribe a permanent position for it.

If *sa* is not a head as argued above, where then is it generated in the sentence? We postulate that *sa* is generated either in [spec, NEGP] or in [spec, TP] whenever the verb subcategorizes for it and *dzí* 'that' appears in COMP following the formula in (20) above. This looks suspicious since Spec-positions are positions for phrasal categories. But if we apply Biloa's (1995 : 129) specifier identity condition, the appearance of *sa* in Spec-position will be licensed.

(21) Specifier Identity Condition

Specifiers of functional maximal projections are unspecified with respect to the identity of the element they must host.

This is further buttressed by the fact that no other element in Lamnso' can co-appear in this position and *whether* in English also appears in [spec, CP]. (22) is the phrase marker of (19) above :

(22).

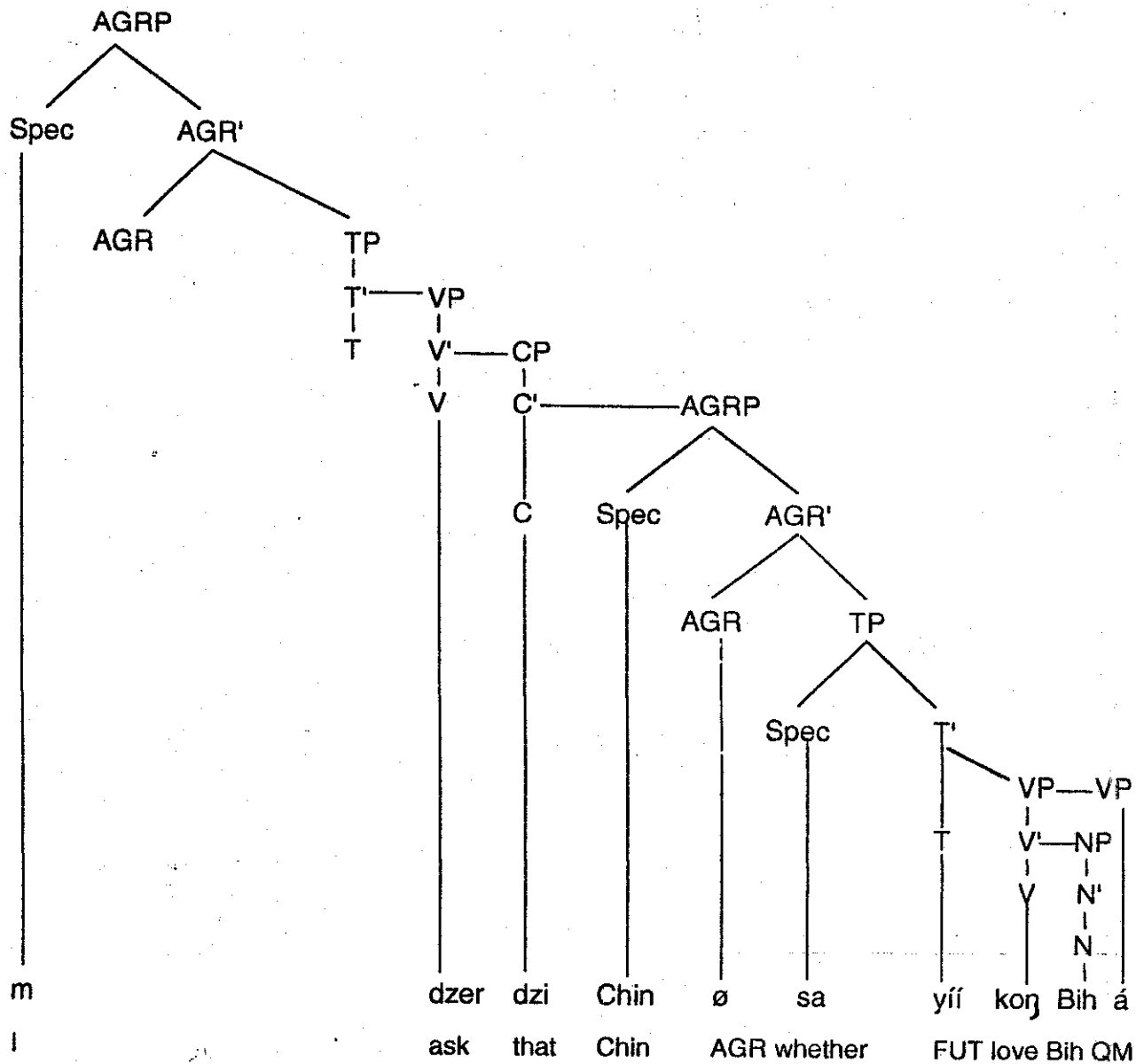

'I am asking whether Chin will love Bih?'

The above analyses show that the verb moves with the following constituents that appear before it, that is, to its left : TNS and NEG (which may carry *sa*, the whether-particle, in one of the spec positions).

3.1.4 THE EFFECT OF V-PREPOSING ON OTHER CONSTITUENTS

It has been shown above that the verb moves with some phrasal constituents to its left. Given that this kind of movement displaces other constituents like tense that equally have a grammatical role to play in the sentence, V - preposing is bound

- c. fɔ́ mó__Bih kibán
 give me Bih fufu
 'It is I who have given Bih fufu'

*Explain the me to
 why understand sub? or
 does the marker disappear?*

In (24a), *mó* 'me' is assigned morphological accusative case. In (24b), *m* 'I' is assigned nominative case because it is in subject position. But in (24c), as the result of verb movement to sentence-initial position, accusative case is assigned to [spec, AGRP]. It is possible to link the disappearance of AGR to the assignment of this kind of case. Given that case is assigned at S-structure, the disappearance of AGR makes the assignment of nominative case impossible since deleted elements have not been known to leave traces. The consequence is that the subject NP is loose and if some governor does not assign it case, it will be ruled out by the case filter. One is tempted to believe that the verb *fó* 'give' assigns accusative case to the NP found on its right. But another question arises from the above assumption: does *fó* 'give' assign accusative case to its right because it is a two-place predicate verb? If so, why does another one-place predicate verb like *wiy* 'come' also behave in the same manner as seen in (25) below :

- (25) a. m wíyí
 I come
 'I am coming'
 b. wíy mó
 come me
 'It is I who am coming'

Another question arising from the above discussion is: if *fó* 'give' in (24c) assigns accusative case because it is a two-place predicate verb, then how many constituents would be assigned the same case, given that *mó* 'me' and *Bih* will be assigned the same case? These questions will be answered in section 4.3 where we make a comparative analysis of this Lamnsó structure with that of English.

3.1.4.2 THE AGRP

As the result of V-preposing, the agreement particle in the sentence disappears. Before we turn to this, first consider the sentences below :

- (26) a. kimbán kí yí yí : kibán
 whiteman AGR Fut eat fufu
 'The whiteman will eat fufu'

- b Chin \emptyset yíí yí kibán
 Chin AGR Fut eat fufu
 'Chin will eat fufu'

In (26b), AGR is realised as zero and in (26a) it is realised as *kí* according to the noun class of the subject NP. *Chin* has no overt AGR because it has no overt noun class marker. So, for AGR to be overtly realised in Lamnsó, it needs that the noun class be overtly marked too. We can, therefore, assume that the zero realisation of AGR in (26b) is some sort of vacuous agreement. Note that, unlike in some Grassfield Bantu languages, personal pronouns in Lamnsó do not take agreement because of the above requirement. It is also realised that some symbiotic relation obtains between AGR and tense, which are separate nodes in the language, AGR only occurs when tense is present but in the absence of tense, AGR may not occur. When there is tense, AGR is obligatory. This means that (27) below is impossible:

- (27) a [+ AGR - tense]
 b [- AGR +tense]

But rather, 28 is right :

- (28) a [+ AGR + tense]
 b [- AGR - tense]

Explains why does AGR disappear?

If AGR is interpreted as showing that a particular NP is the subject of a particular verb, then its disappearance is accounted for by the fact that the verb has been displaced and there is nothing to agree with. This assumption is buttressed by the fact that the directionality of agreement is to the right of the NP and not to the left, such that the verb can move with any other constituent and not AGR. Another question is when does agreement occur in the language? At D-structure or at S-structure? (26a) shows that the AGR node is generated in the base complement. What ever the case, (29) below shows that the AGRP takes TP as its complement according to the X-bar format and that they respect some kind of precedence, especially when the subject NP is the target of WH-movement.

- (29) [_{AGRP} kimbáj] [_{CP} ke [_{AGRP} kí wiyin]]kí yí kibán
 whiteman that he come AGR eat fufu
 'The whiteman that has come eats fufu'

(30a) is a simple sentence. In (30b), *Bih*, the ^{subject} subject of *kôŋ* 'love', has been put to focus. Two transformations have occurred: *dze* 'is' has been inserted and a 'it' has assumed its subject position. Accordingly, the copula will be base-generated in front of any constituent to give it focus prominence.

We showed in section 2.6.2.2 that clefting is an integral part of WH-movement in Lamnsó, that is, a question word cannot be fronted to sentence initial position without a copula preceding it. Consider the sentences in (31) below :

- (31) a Chin \emptyset \emptyset kôŋ lá
 Chin SM TNS love who
 'Chin loves who?'
- b. *lá Chin \emptyset \emptyset kôŋi
 who Chin SM TNS love
 'who does Chin love'
- c. *lá wō Chin \emptyset \emptyset kôŋi
 who that Chin SM TNS love
 'who does Chin love'
- d. dze lá wō Chin \emptyset \emptyset kôŋi
 is who that Chin SM TNS love
 'It is who that Chin loves'

(31b) is a word for word translation from English and is ungrammatical because *lá* 'who' has been moved to sentence initial position and has no copula preceding it and no operator linking it to the rest of the sentence as it will be done to an overt NP like *Bih*. In (31c), *lá* 'who' has an operator but lacks a copula in front of it, so the sentence is ungrammatical. (31d) is grammatical because it has an operator and is preceded by a copula. This phenomenon whereby clefting is used for WH-movement is a common feature with most Grassfield Bantu languages and stresses the importance of clefting to those languages. But the case of Lamnsó is peculiar in that the subject position of the inserted copula is left empty at sentence-initial position.

3.2.2 THE EXPLETIVE-a

Following the extended projection principle (EPP), sentences must have subjects regardless of their argument structure :

(32) Extended Projection Principle

$$S \rightarrow NP _ AUX _ VP$$

The rule in (32) requires that INFL, whose complement is the VP, must have its [Spec, IP] position occupied by a subject NP, irrespective of whether it is assigned a theta role or not. In English, dummy subjects such as *it* and *there* are said to appear in [spec, IP] to satisfy this condition. Similarly, in Lamnso', after the generation of the copula in front of a base constituent, an expletive *a* is also generated in [spec, IP] of the copula to play the role of a slot holder of that position. This is illustrated below :

- (33) a. *Chin \emptyset \emptyset kôŋ [_{IP} \emptyset dze Bih]
 Chin SM TNS love is Bih
 'it is Bih that Chin loves'
- b. Chin \emptyset \emptyset kôŋ [_{IP} a dze Bih]
 Chin SM TNS love it is Bih
 'it is Bih that Chin loves'

The ungrammaticality of (33a) shows that, in Lamnso', the generation of the expletive *a* in front of a clefted constituent which is at base is obligatory.

3.2.3 THE OCCURRENCE OF THE COPULA AND OBJECT NPs

As it has been stated above, all post - verbal constituents appeal to copula-insertion in order to gain focus prominence as seen in the case of object NPs in (34) below :

- (34) a. Chin \emptyset \emptyset kôŋ Bih
 Chin SM TNS love Bih
 'Chin loves Bih'
- b. Chin \emptyset \emptyset kôŋ a dze Bih
 Chin SM TNS love it is Bih
 'It is Bih that Chin loves'

It is also possible to have *Bih* in (34a) above clefted at sentence initial position. Consider (35) below :

- (35) a. Bih wō Chin \emptyset \emptyset kôŋi[_{NP}----]
 Bih that Chin SM TNS love
 'Bih that Chin loves'

- b. [ø dze Bih] wō Chin ø ø kōŋ[_{NP}-----]
 is Bih that Chin SM TNS love
 'It is the Bih that Chin loves'

In (35a), *Bih* has been moved to sentence initial position. In (35b), a copula is inserted in front of it to give it focus prominence. Bear in mind that clefting the object NP *Bih* at base or after it has been moved is not just a free choice if we notice the slight shift in meaning between (34b) and (35b) above. *Bih* becomes *the Bih*, a particular *Bih* that the speaker and the listener know to be loved by *Chin*.

It is necessary to note, at this level, that copula insertion can alternatively be used for the clefting of subject NPs though with a lot of restriction as seen below :

- (36) a. Chin ø ø kōŋ Bih
 Chin SM TNS love Bih
 'Chin loves Bih'
- b. *ø dze Chin ø ø kōŋ Bih
 is Chin SM TNS love Bih
 *'is Chin loves Bih'
- c. *a dze Chin ø ø kōŋ Bih
 it is Chin SM TNS love Bih
 *'It is Chin loves Bih'
- d. ø dze Chin wō wu ø ø kōŋ Bih
 is Chin who RESUMP. Pron SM TNS love Bih
 *'It is the Chin who loves Bih'

(30b) and (30c) are ungrammatical because the copula has been inserted in the same way as it would be done with object NPs (see 34b). The ungrammaticality shows that something needs to occur before such an insertion occurs. (36d) shows that *Chin* has to be first of all relativised before the copula is inserted and that since it is at the beginning of the sentence, the expletive is realised as zero.

We said in section 3.1. that verb movement is used for clefting subject NPs as seen in (37) below :

- (37) a. Chin ø ø kōŋ Bih
 Chin SM TNS love Bih
 'Chin loves Bih'

- b. ø kôŋ Chin — Bih
 TNS love Chin Bih
 'It is Chin who loves Bih'

when we compare (37b) with (36d), we realise that there is a slight shift in meaning; that of something definite, *the Chin*. The above discussion shows that copula insertion in front of a subject NP is not purposeless or just a free choice. We can, therefore, conclude that, in Lamnso', the clefting of constituents after they have undergone WH - movement is to give them a definite meaning.

3.2.4 THE OCCURRENCE OF THE COPULA AND PPS

In Lamnso' as in English, a PP can be clefted. According to Riemsdijk and Williams (1986 : 102), if a PP appears in the focus position (the position following *it* *be* generated at base after WH - movement) then *that* must appear in COMP as seen from the fact that (38a) below is ungrammatical :

- (38) a. *It was to John to whom I spoke.
 b. It was to John that I spoke.

In Lamnso', a similar process occurs though with some slight variations as seen below :

- (39) a. Chin fó kibán í lá
 Chin give fufu to who
 'Chin is giving fufu to whom'
- b. Chin fó kibán a dzě lá
 Chin give fufu it is who
 'It is to whom that Chin is giving fufu'
- c. dzě Bih wō Chin fó kibán
 is Bih whom Chin give fufu
 'It is to Bih that Chin is giving fufu'
- d. dze Bih wō Chin fó kibán sh-ō
 is Bih whom Chin give fufu RESUMP. Pron.
 'It is the Bih to whom Chin is giving fufu'

In (39b), the insertion of the copula deletes the preposition. It is also observable that the low tone on *dze* is modified into a low - high contour tone. In (39c), the contour tone on *dzě* in sentence-initial position equally comes from the deletion of /'to' whose high tone links up to the low tone of *dze* to yield *dzě*. The original low tone on *dze* in

(39d) and the resumptive pronoun of the moved NP position at the end of sentence show that only the PP - NP has been extracted and clefted.

3.2.5 THE OCCURRENCE OF THE COPULA AND ADJUNCTS

As it is the case in English, adjuncts in Lamnso' can also be clefted. Consider the following sentences :

- (40) a. Chin wíy í ghanká
Chin come at what time
'Chin is coming when'
- b. Chin wíy a dzě ghanká
Chin come it is what time
'It is when that Chin is coming'
- (41) a. Chin wíy lán
Chin come today
'Chin is coming today'
- b. Chin wíy a dze lán
Chin come it is today
'It is today that Chin is coming'
- (42) a. Chin dū í ntó
Chin go to palace
'Chin is going to the palace'
- b. Chin dū a dzě ntó
Chin go it is palace
'It is to the palace that Chin is going'

In the (b)-examples in (40) and (41) above, the same process as seen with prepositions occurs; the preposition *í* to/at disappears and the tone is borne by *dze*, the copula. Notice that the examples show only adjuncts of place and time. This is because adjuncts of manner cannot be clefted in Lamnso' as seen in the ungrammaticality of (43b) below :

- (43) a. Chin ø - ø yí kibán cércér
Chin SM TNS eat fufu fast fast
'Chin is eating fufu very fast'
- b. *Chin ø ø yí kibán a dze cércér
Chin SM TNS eat fufu it is fast fast
'*It is very fast that Chin is eating fufu'

From the fact that the English translation of (43b) is also ungrammatical , we could suppose that it is a universal issue that manner-adjuncts cannot be clefted.

It is also worthy noting that cleftable adjuncts (adjuncts of time and place) can be moved to clause initial position. Consider the sentences below :

- (44) a. Chin dũ a dzě ntó
 Chin go it is palace
 'It is to the palace that Chin is going'
- b. dzě ntó wó Chin dũ sh-o
 is palace that Chin go RESUMP. Prom
 'It is the palace where Chin is going'
- c. dze ntó wó Chin dũ
 is palace that Chin go
 'It is the palace that Chin is going'

In (44a), *Ntó* 'palace' is clefted at its base position. In (44b), it is clefted at its new position where it has been moved. From the translation, the focus is on *the palace*. But in (44c), the focus is on the whole PP to judge from the disappearance of the resumptive pronoun and from the contour tone on *dze*.

3.2.6 THE OCCURRENCE OF THE COPULA AND CLAUSES

In section 2.6, we discussed a rule assumed to govern embedding in Lamnso'. We saw that only tensed clauses, that is, that-complements can be embedded. We cited a unique case of Equi-NP-deletion where an infinitival clause could be embedded if the subject of its verb (PRO) is equal to or controlled by that of the verb in the matrix clause as seen below :

- (45) a. Chin, ø ø tâ' [PRO, fô du]
 Chin SM TNS want to go
 'Chin wants to go'
- b. *Chin ø ø tâ' Bih, [PRO, fô du]
 Chin SM TNS want Bih to go
 'Chin wants Bih to go'
- c. Chin ø ø tâ' dzí Bih ø ø dũ
 Chin SM TNS want that Bih SM TNS go
 'Chin wants that Bih should go'

In Lamnso', clause clefting is possible, that is, embedded infinitival clauses and that-complements can be given focal prominence at their base positions through copula-insertion. As it will be seen from the translations, such constructions read in English as pseudo-cleft constructions. Consider (46) below :

- (46) a. Chin, \emptyset \emptyset tâ' [a dze PRO, fô du]
 Chin SM TNS want it is to go
 'what Chin wants is to go'
- b. Chin \emptyset \emptyset tâ' [a dze dzí Bih \emptyset \emptyset dû
 Chin SM TNS want it is that Bih SM TNS go
 'what Chin wants is that Bih should go'
 or 'what Chin wants is for Bih to go'

In (46a) and (46b), the embedded IP has been put to focus through the use of copula insertion. It is worthy noting that, unlike with other phrasal constituents, as seen above, an IP cannot be moved to sentence-initial position. This may be because every element that is moved to COMP in the language (NPs and WH-phrases alike) must have a relative operator or focus word enabling them to be strung to the rest of the sentence and since the selection of such relative operators is restricted by spec-head agreement (see 47 below) governed by the noun class system in the language and given that IPs do not have noun classes, an IP moved to sentence-initial position will be loose and not strung to the rest of the sentence. The above facts are illustrated below :

- (47) a. Bih wō Chin \emptyset \emptyset kôŋi
 Bih that Chin SM TNS love
 'The Bih that Chin loves'
- b. dze lá wō Chin \emptyset \emptyset kôŋi
 is who that Chin SM TNS love
 'It is who that Chin loves'
- c. kimbán ké Chin \emptyset \emptyset kôŋi
 white man that Chin SM TNS love
 'The white man that Chin loves'
- d. vimbán vé Chin \emptyset \emptyset kôŋi
 white men that Chin SM TNS love
 'The white men that Chin loves'
- e. *_[IP] \emptyset dze fô du] ----- Chin tâ' [_{IP} -----]
 is to go Chin want
 'It is going that Chin wants'

Though not representing all the noun classes in the language, (47a) to (47d) show that relative operators (underlined in the examples) in Lamnso' depend on the nouns they follow for their forms through the process of agreement. (47e) is ungrammatical

because an IP has been moved and IPs are not specified for noun class in the language.

The sentences below illustrate other pseudo-cleft structures in the language. From the distribution of *fô du* 'to go', it will be seen that the assumptions on the restriction on IP-movement above are founded.

- (48) a. Chin_i ø ø tâ' [PRO_i fô du]
 Chin SM TNS want to go
 'Chin wants to go'
- b. [_{IP}ke Chin tâ'] kí dze fô du
 what Chin want SM is to go
 'What Chin wants is to go'
- c. [_{IP}PRO_i fô du] dze ké Chin_i tâ'
 to go is what Chin want
 'Going is what Chin wants'
 or 'It is going that Chin wants'

(49c) is grammatical because the bracketed IP is a nominal clause playing the traditional role of subject. It is, therefore, clear that IPs can only remain at base and that no movement transformation can apply to them. Nevertheless, they can stand in for NPs at various positions as shown in (48a) and (48c) above

3.2.7 a-DELETION IN SENTENCE-INITIAL POSITION

we have said in the foregoing discussion that two transformations occur when a post-verbal constituent is clefted :a copula is inserted and an expletive *a* 'it' assumes its subject position. This happens when clefting applies to a constituent at its base position. But it is observable from (50) below that when the copula is inserted at sentence-initial position, the *a* deletes or is rather not generated obligatorily.

- (50) a. Chin ø ø kôŋ Bih
 Chin SM TNS love Bih
 'Chin loves Bih'
- b. Chin ø ø kôŋ a dze Bih
 Chin SM TNS love it is Bih
 'It is Bih that Chin loves'

- c. \emptyset dze Bih wo Chin \emptyset \emptyset kôŋi
 is Bih that Chin SM TNS love
 'It is the Bih that Chin loves'
- d. * a dze Bih Chin \emptyset \emptyset kôŋi
 It is Bih Chin SM TNS love
 'It is the Bih that Chin loves'

(50d) is ungrammatical because the subject position of *dze* 'is' filled. (50c) is grammatical because the position is empty. If we assume that every verb has at least a subject position, then we must account for the empty subject position in (50c). we postulate that the position is occupied by the invisible null element, 'small pro'. Hence, (50c) will read as (51) :

(51) 'pro dze Bih wo Chin \emptyset \emptyset kôŋi

The question that arises from the above assumption is how pro in (51) is recovered and licensed. Lamnso' is not a pro-drop language in the sense that its verbal inflection as can be seen in (52) below is not rich enough to license pro :

(52) *fô du* 'to go' future tense

- a. m yíí - du
 I FUT go
 'I will go'
- b. a yíí - du
 You FUT go
 'You will go'
- c. wu yíí - du
 He FUT go
 'He will go'
- d. ver yíí - du
 We FUT go
 'We will go'
- e. ven yíí - du
 You FUT go
 'You will go'
- f. áwúni yíí - du
 They FUT go
 'They will go'

Though the verbs are conjugated in one form, *yíí - du*, throughout the various persons, we need to account for such an empty category in the language. The

answer could be that *pro* does not need to be recoverable in this context because of the fact that *a* is an empty word, a slot holder that does not serve any interpretative function in the sentence. This explanation is not new if we take examples from other languages. Expletive pronouns in Italian are realised as *pro* (Haegeman, 1991 : 414). The absence of subject-verb agreement in a language does not block *pro* because, similarly, Chinese is a *pro*-drop language with no subject-verb agreement (Haegeman, 1991 : 418).

3.4 SUMMARY

This chapter has been principally concerned with the presentation of the Lamnso' data relating to clefting. It has been shown that two processes are involved in clefting in Lamnso' : verb movement and copula-insertion . Both processes can be subsumed into a requirement that a verb must come before a constituent in order to give it focus prominence.

As concerns subject NPs, we have shown that they are clefted typically through verb movement though copula insertion could apply with a lot of restrictions. It has been demonstrated that there is no restriction as to the kind of verb that can move and that when the verb moves, it has an effect on other constituents in the sentence. On the one hand, it moves with the heads of phrasal categories to its left such as NEG, TNS and *sa*, the whether-particle. On the other hand, a subject NP loses its nominative case as the result of verb movement and is assigned accusative case in its stead. We have also noted that AGR disappears in this process. As far as post-verbal constituents (including embedded phrases) in a sentence are concerned, it has been shown that copula insertion is the only process involved in clefting. We have indicated that the copula could be inserted at the base position of the constituents or after the constituent has been relativised. We have distinguished between both kinds of copula-insertion. At the semantic level, we have shown that, when the copula is inserted at sentence-initial position, there is a slight shift in meaning; that of definiteness. At the structural level, it has been observed that when the copula is inserted at base, it takes an expletive *a* 'it' and that when it is inserted at clause-initial position, there is no *a*. This has led us to posit that the subject position without the expletive *a* could be replaced by *pro*. It has also been shown that both

clefting processes are very useful in Lamnso' in that they serve as paraphrases for passive constructions and help in the movement of WH-phrases.

The next chapter takes a closer look at the data presented in this chapter by relating them to existing theories in Universal Grammar so as to highlight parametric variations.

V-PREPOSING AND SENTENCE STRUCTURE

INTRODUCTION

The aim of this Chapter is to attempt a descriptively adequate analysis of the phenomenon seen in Chapter Three of this study. The focus is, therefore, on how the data from Lamnso' could be analysed. Section one deals with the problem of the landing site for preposed verbs by relating it to other WH-movement processes in the language. Section two looks at the behaviour of V-traces in relation to some principles such as the empty category principle (ECP). Section three examines the assignment of accusative case to [spec, AGRP] after V-movement. In section four, we argue that V-preposing respects Subjacency.

4.1 THE LANDING SITE OF PREPOSED VERBS

way To have a clearer argument about the landing site of preposed verbs, it is first of all necessary to determine where WH-phrases and relative operators raise to in Lamnso'. It is demonstrated below that the data from Lamnso' displays some similarities with the data from Tuki discussed in Biloa (1995). Consider the following sentences from Tuki :

- (1) a. ane odzu Puta a - nu banam
 who FOC Puta SM F1 marry
 'who will Puta wed ?'
- b. ate aye Puta a - ma namba
 what FOC Puta SM P2 cook
 'what did Puta cook?'
- (2) a. Dima odzu Puta a - nu banam
 Dima FOC Puta SM F1 marry
 'It is Dima that Puta will wed'
- b. adzakasa aye Puta a - na namba
 donkey FOC Puta SM P2 cook
 'It is the donkey that Puta cooked'

Biloa (1995) argues that in (1), it is the WH-word that is fronted and in (2) it is an 'ordinary' NP that is fronted. But that in the (a)-examples, the same focus word is used and in the (b)-examples in (1) and (2), the same focus word is also used. He also says that FOC represents the focus word which agrees in noun class with the focused elements. (3) and (4) below show the data from Lamnso' with sentences similar to (1) and (2) :

- (3) a. dze lá wō Puta ø yí - marir
is who FOC Puta SM FUT marry
'who will Puta wed?'
- b. dze ká ke Puta ø yí - náà
is what FOC Puta SM FUT cook
'what will Puta cook?'
- (4) a. dze Dima wō Puta ø yí - marir
is Dima FOC Puta SM FUT marry
'It is Dima that Puta will wed?'
- b. dze kimbe'bih ke Puta ø yí - náà
is donkey FOC Puta SM FUT cook
'It is the donkey that Puta will cook?'

(3) and (4) above show that the data from Lamnso' has some similarities with the data from Tuki in that both WH-phrases and NPs need a focus word when fronted as seen in the appearance of *wō* in the (a)-examples and of *ke* in the (b)-examples. It should also be noted that FOC equally comes from noun class agreement in the Lamnso' examples. The only slight difference is the appearance, in the Lamnso data, of *dze*, the copula, in front of fronted elements. Biloa (1995 : 66,(46)) shows that the copula is optional as evidenced below :

- (5) [(i - mu) XP CP IP]

Following the rule in (5), it is possible that the data in (1a) and (2a) would be as (6a) and (6b) respectively.

- (6) a. (i - mu) ane odzu Puta a - nu banam
It is who FOC Puta SM F1 marry.
'It is who that Puta will wed?'
- b. (i - mu) Dima odzu Puta a - nu banam
It is Dima FOC Puta SM F1 marry
'It is Dima that Puta will wed?'

If we compare (6) with (3) and (4), we will conclude that the copula is obligatory in Lamnso' but optional in Tuki. Biloa (ibid, P. 66) concludes that in both WH-questions and cleft constructions, the same presuppositional structure is shared. About where the fronted elements land, Biloa (ibid, P. 51) postulates that there is a phrasal constituent between CP and IP called Focus Phrase (FP) and that "relative operators raise to [spec, CP] while question operators raise to [spec, FP]". Having discussed the similarities between Tuki and Lamnso', let us represent the (a)-examples in (1) and (3) on a tree diagram. All unnecessary details are left out.

(7) a. ane odzu Puta a - nu - banam

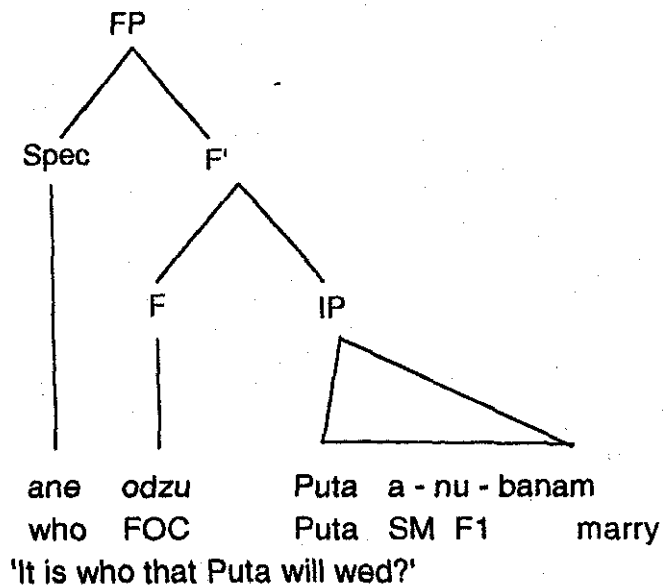

b. pro ø ø dze lá wō Puta ø yíi-marir

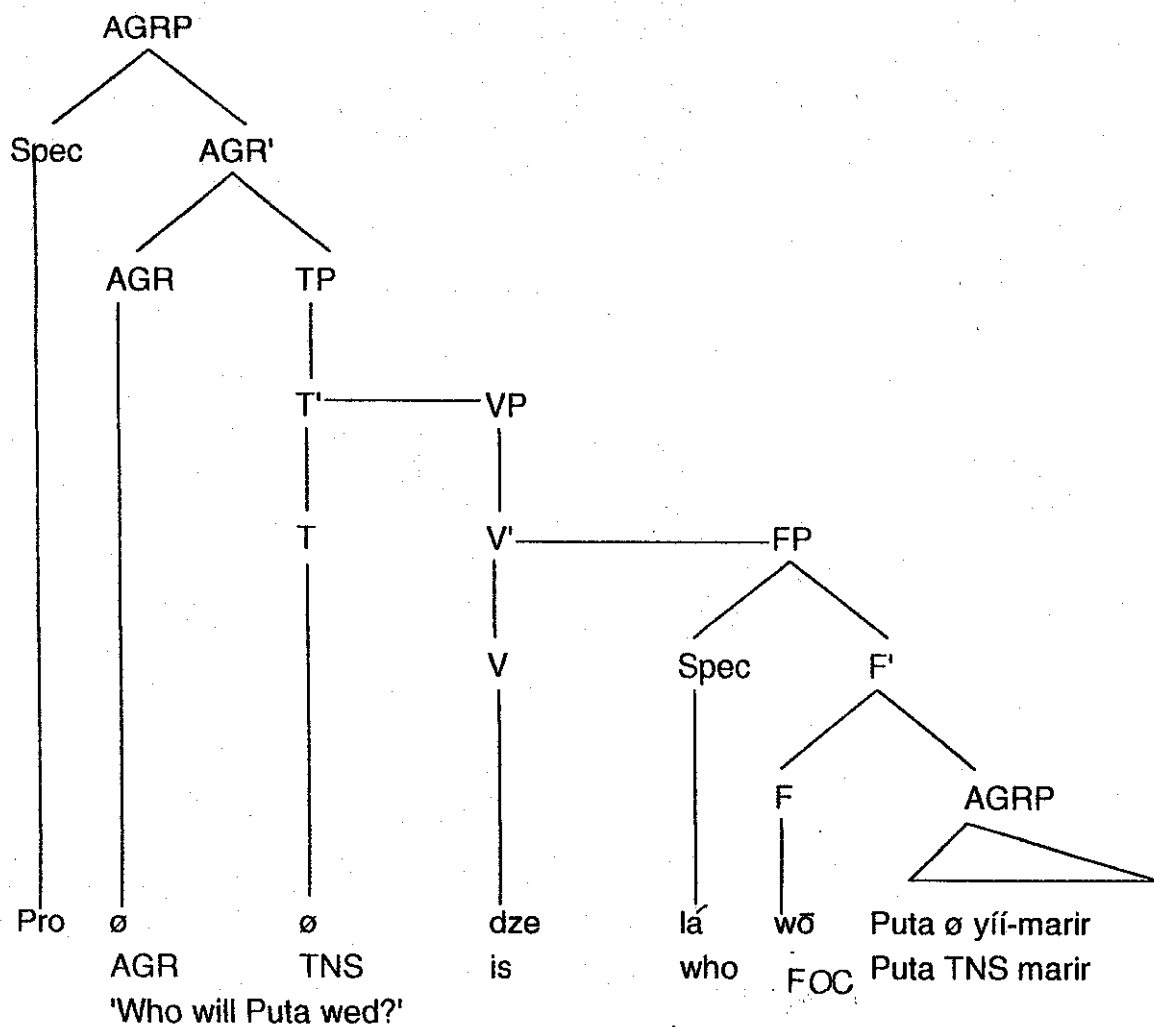

In (7b), the specifier position of the AGRP is occupied by small pro. AGRP takes a TP-complement, TP takes a VP-complement and VP takes an FP-complement. (8) below shows that the whole of (7b) can be embedded. In such a case, it is introduced by the lexical complementizer dzi 'that'.

- (8) a. wu ø suy [_{CP} dzi pro ø ø dze lá wō Puta ø ø konji]
 He TNS say that AGR TNS is who FOC Puta AGR TNS love
 'He is saying that it is who that Puta loves'

A question?
or statement?

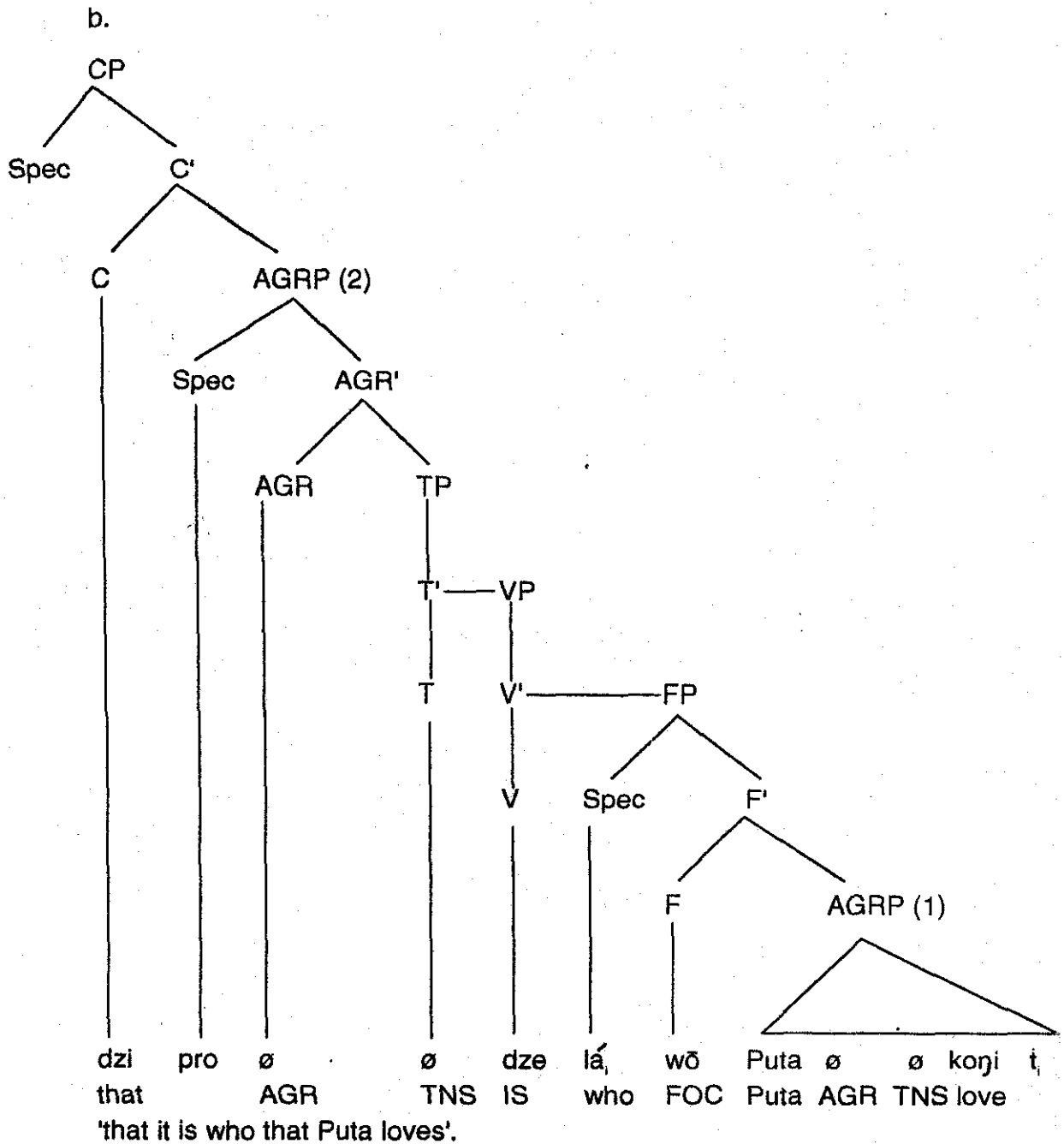

(8b) shows that, unlike in Tuki, the complement of *dzi*, the lexical complementizer, is an AGRP (AGRP(2)) and not an FP. On the strength of (8) above, we can propose that in Lamnso', unlike in Tuki, we should not postulate an FP as the landing site for focused WH-elements of AGRP(1) but rather a CP because of the following reasons:

- (i) CP and FP in (8b) take AGRP(2) and AGRP(1) as complements, so it will be logical to postulate a CP where there is FP.

- (ii) No complementizer can come between FP in (8b) and AGRP(1) as seen from the ungrammaticality of (9) below.

- (9) *dze [_{FP} lá [_F wō [_{CP} dzi Puta Konji]]]
is who FOC that Puta love

The ungrammaticality of (9) results from the fact that *wō* is supposed to occupy the C-position and, as a result, *dzi* 'that' whose traditional position is the C-position cannot be generated concurrently in the same position. Hence, (8b) will alternatively be represented as (10) below :

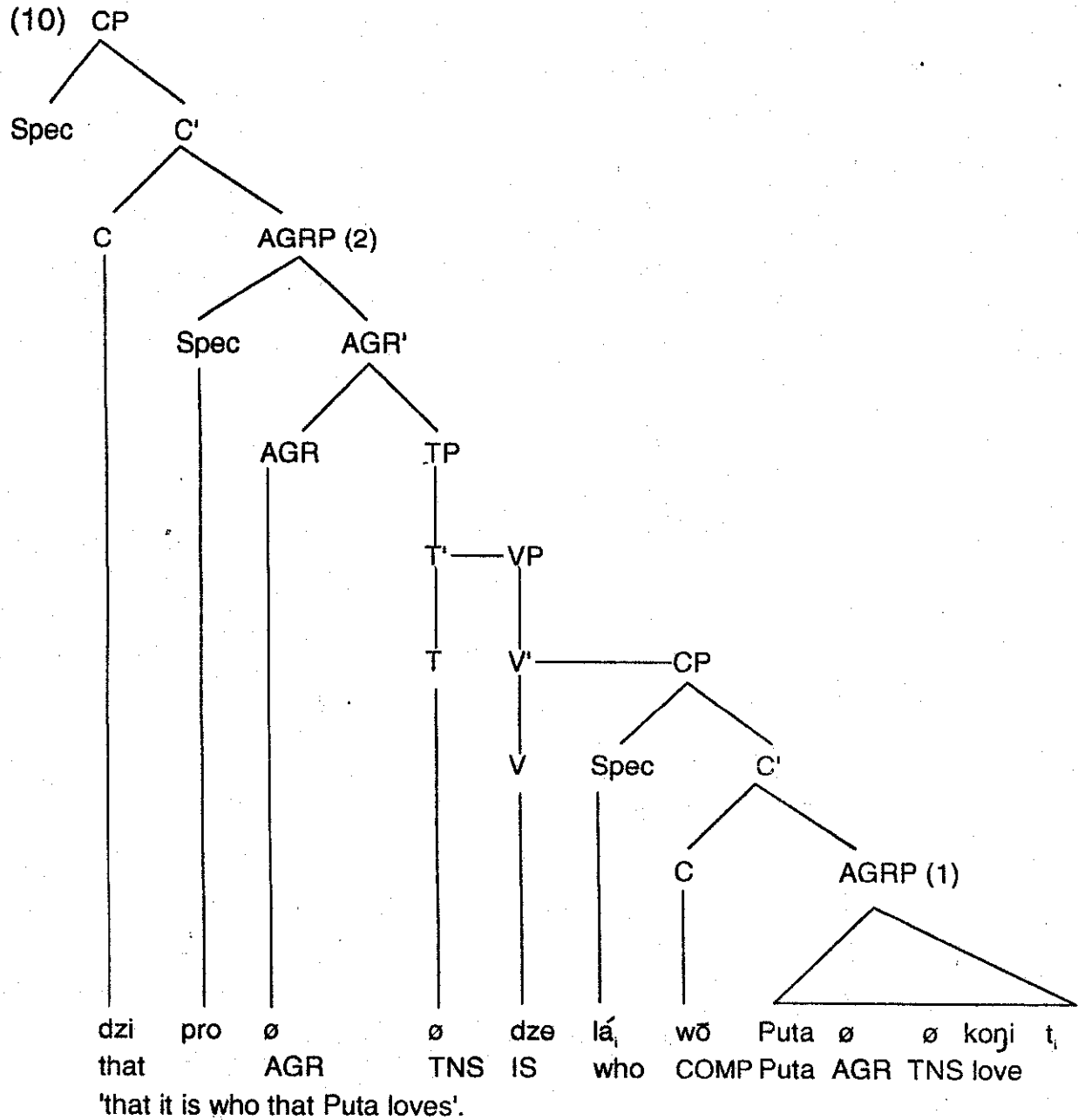

In (10) above, the WH-word *lá* 'who' occupies its traditional position of [spec, CP] and the focus word *wō* is generated under C in conformity with what has been called spec-head agreement.

4.1.1 SOME PECULIARITIES OF V-MOVEMENT IN LAMNSO'

We demonstrated in section 3.1 that V-movement in Lamnso' is accompanied by all verb related constituents to the left of the verb such as TNS and NEG as seen below :

- (11) a. *kimbán* *ki* [_{NEGP} *yo'* [_{TP} *yíí* - *yī* *kibán*]]
 white man AGR NEG TNS m eat fufu
 'The white man will not eat fufu'
- b. [*yo'* *yíí* - *yī*]_i *kimbán* *X_i* *kibán*
 NEG TNS eat white man fufu
 'It is not the white man that will eat fufu'

In (11a), *yo'* 'not' and *yíí* 'will' are generated at their base positions. In (11b), because of verb movement, they have also moved to sentence-initial position. The question is to know where the preposed verb lands and where the accompanying heads of phrases land. It should be borne in mind that V-movement is not focus-V-movement. It is used to put the NP that follows the preposed verb into focus. It is perhaps logical to consider the preposed verb as the focus word because, if it comes in front of an NP to give that NP focus prominence, then it assigns the function of focus to that NP. This focus word will be the head of the focus phrase (FP). Consider (12) below :

- (12) a. *Chin* *kōŋ* *Bih*
 Chin love Bih
 'Chin loves Bih'
- b. *kōŋ*_i *Chin* *t_i* *Bih*
 love Chin Bih
 'It is Chin that loves Bih'

In (12b), *Chin* is given focus prominence because the verb *kōŋ* 'love' has been moved to sentence-initial position. (13) is the tree diagram representation of (12b) :

(13)

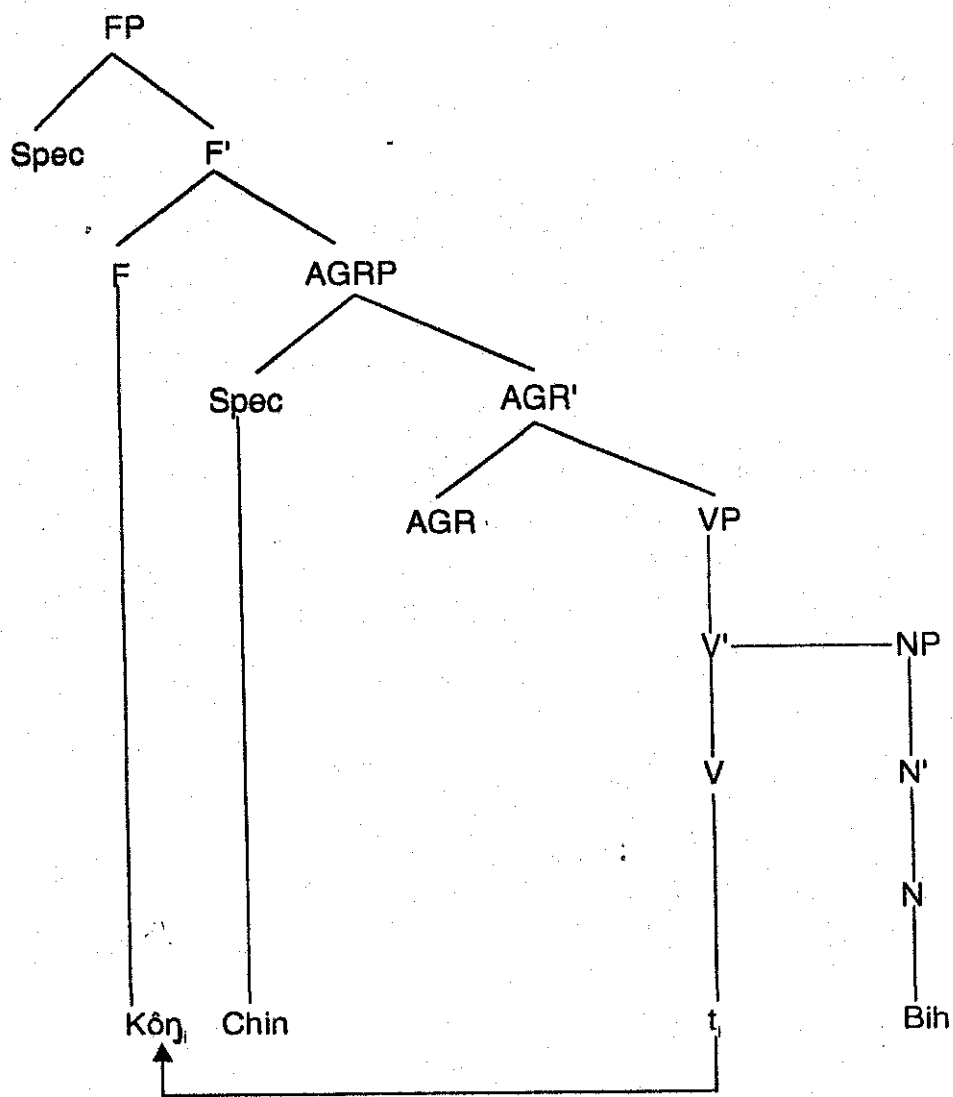

love Chin
'It is Chin that loves Bih'.

Bih

How can the phenomenon in (13) be integrated into the foregoing discussion? We have argued that fronted WH-elements are hosted by CP. We have shown in (10) above that in a sentence like (14) below, *wõ* is generated under the C-node.

- (14) *dze* [_{CP} *lá* *wõ* Chin *konj*]
 is who COMP Chin love
 'Who does Chin love?'

It is necessary to note at this level that, in Lamnso', V-movement can take place in an embedded clause as seen below :

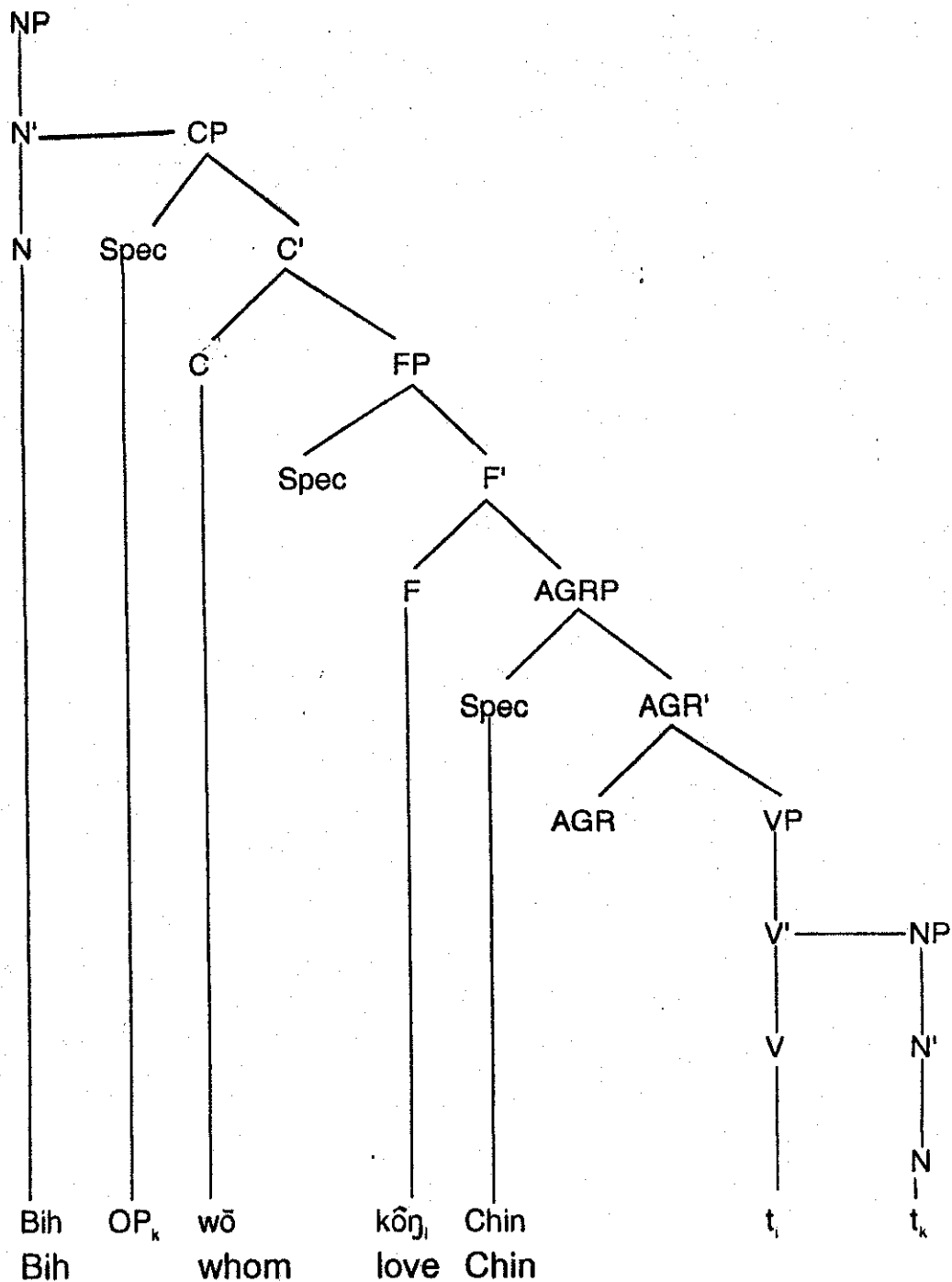

* (The) Bih whom it is Chin that loves'

Another important fact to note is that V-preposing can occur simultaneously in the matrix and in the embedded clauses. Consider (18) below :

- (18) a. m suy dzi Chin kōŋ Bih
 I say that Chin love Bih
 'I am saying that Chin loves Bih'

- b. *suy*_i *mō* *t*_i *dzi* *Chin* *kōŋ* *Bih*
 say me that Chin love Bih
 'It is I who am saying that Chin loves Bih'
- c. *suy*_i *mō* *t*_i [_{CP} *dzi* *kōŋ*_k *Chin* *t*_k *Bih*
 say me that love Chin Bih
 'It is I who am saying that it should be Chin who loves Bih'

In (18b), the verb *suy* 'say' of the matrix clause has been preposed to sentence-initial position. In (18c), the verb *kōŋ* 'love' of the embedded clause has also been preposed to the position below CP. On the strength of the above arguments, we conclude that V-preposing in Lamnso' is substitution for a phrasal category between CP and AGRP which we call FP. It is also a head-to-head movement because the verb has moved from a head position to another head position. This is in respect of the structure preserving principle which states that structures established at D-structure must be preserved at S-structure.

4.2.2 THE LANDING SITE FOR CONSTITUENTS ACCOMPANYING THE PREPOSED VERB.

The next question we need to ask is to know where the other phrasal heads that move with the verb land. Let us first of all take a look at the tense phrase (TP). Consider (19) below :

- (19) a. *kinbáŋ* *ki* *yíí - kōŋ* *Bih*
 white man AGR FUT love Bih
 'The white man will love Bih'
- b. *yíí_k - kōŋ_i* *kinbáŋ* *t_k* *t_i* *Bih*
 ↑ ↑ ↑ ↑
 FUT love white man Bih
 'it is the white man that will love Bih'.

The first comment about (19b) above is that the verb and its tense affix are strongly bound together and are, as a result, inseparable. This shows that verb affixes are strong in Lamnso' and must be overtly attached to their verbs, that is, they cannot be stranded. According to Travis' (1984) head movement constraint (HMC) quoted in Radford (1997 : 225), a head can only move from one head position in a phrase to the other head position of another phrase. Head movement is, therefore, a local movement in that constituents move to the next highest phrase in the tree. (19b)

shows that, the verb cannot move over tense; so it first adjoins to tense and both heads raise to sentence-initial position. If we consider the above analyses, we will need to create a separate node as the landing site of tense when the verb lands in the F of FP. To avoid this complexity, we may consider Lasnik's (1981) morphological principle quoted in Koopman (1984: 149):

(20) Morphological Principle

A morphologically realised affix must be realised as a syntactic dependent at S-structure.

This implies that at S-structure, we do not need to create a separate node for the tense morpheme because tense, as stated above, is morphologically bound to the verb and will occupy one head position, the F of FP. (21) is the tree diagram representation of (19b) :

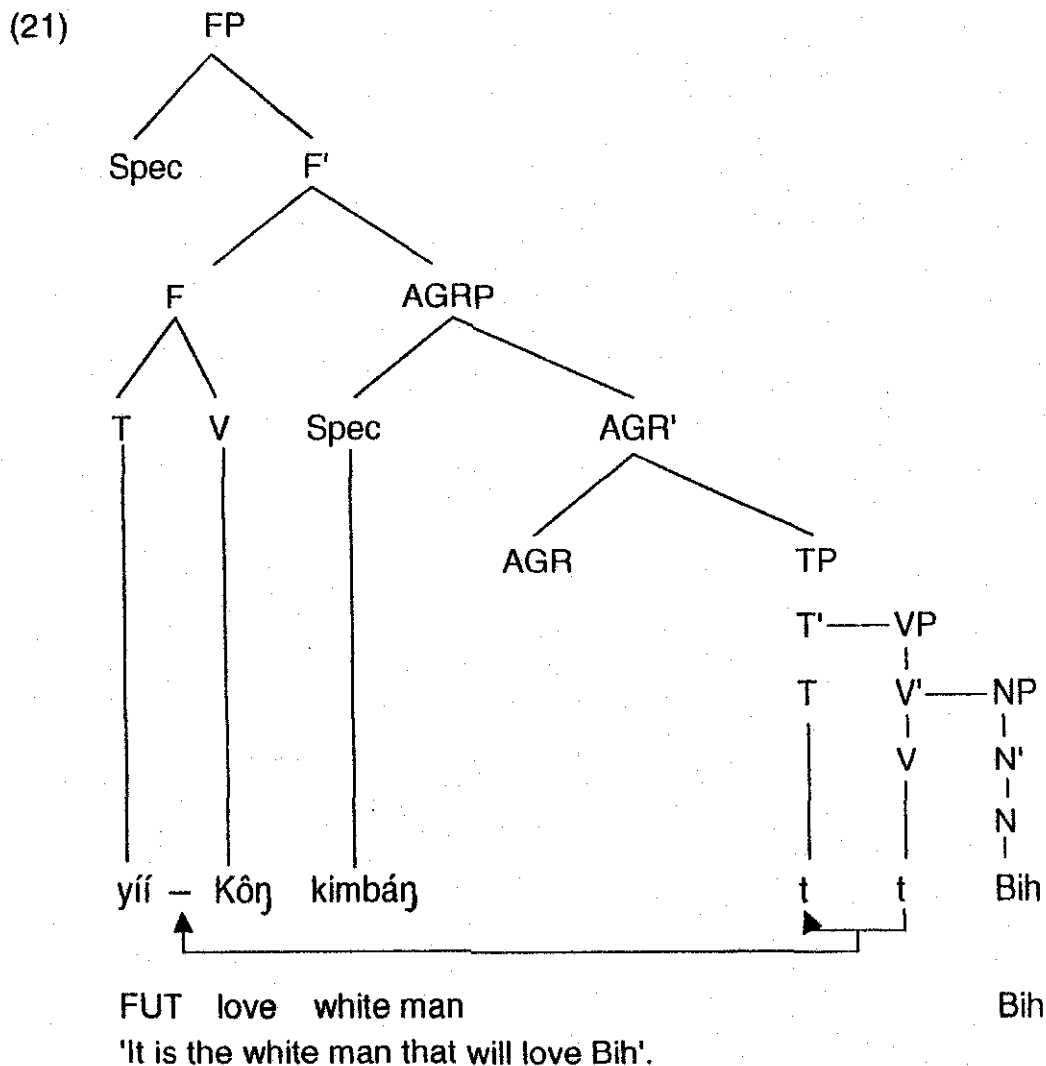

(23)

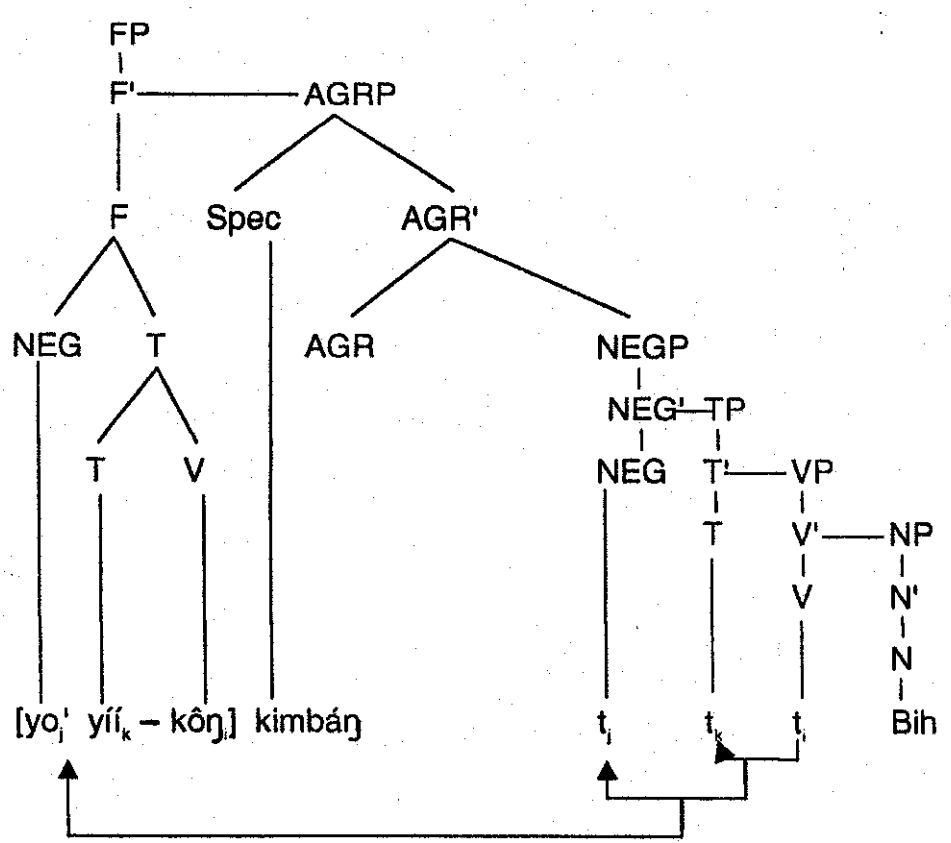

(23) above is a successive cycle movement. The verb first adjoins to tense. Both heads then adjoin to NEG before the whole load is being carried to the F-node in sentence-initial position. All the various stages or cycles of movement are local and, therefore, respect the economic principle that favours shorter movements. Since the links are minimal, they also respect Travis' (1984) head movement constraint.

4.2 V-TRACES AND PROPER GOVERNMENT

In the literature, the movement of elements to a derived position leaves traces at the base position. In Lamnso', it is possible to posit a verbal trace after V-preposing. Consider (24) below :

- (24) a. Chin kôn Bih
Chin love Bih
'Chin loves Bih'
- b. kôn Chin ___ Bih
love Chin Bih
'It is Chin who loves Bih'.

the proper government of the V-trace is done through antecedent government with the verb in FP with which it is coindexed.

One other interesting thing about V-traces in Lamnso' that does not occur in koopman's (1984) Vata-analyses (where the verb and WH-phrases move to the same place and, therefore, are in complementary distribution) is that it can govern NP-internal-argument traces. This means that after the verb has been preposed to the FP, its internal argument can still be moved to COMP or vice versa. Consider (27) below :

- (27) a. Chin kôŋ Bih
 Chin love Bih
 'Chin loves Bih'
- b. kôŋ_i Chin X_i Bih
 love Chin Bih
 'It is Chin who loves Bih'.
- c. Bih_k wǝ kôŋ_i Chin X_i X_k
 Bih whom love Chin

'The Bih whom it is Chin who loves'

(28) is the phrase marker of (27c):

(28)

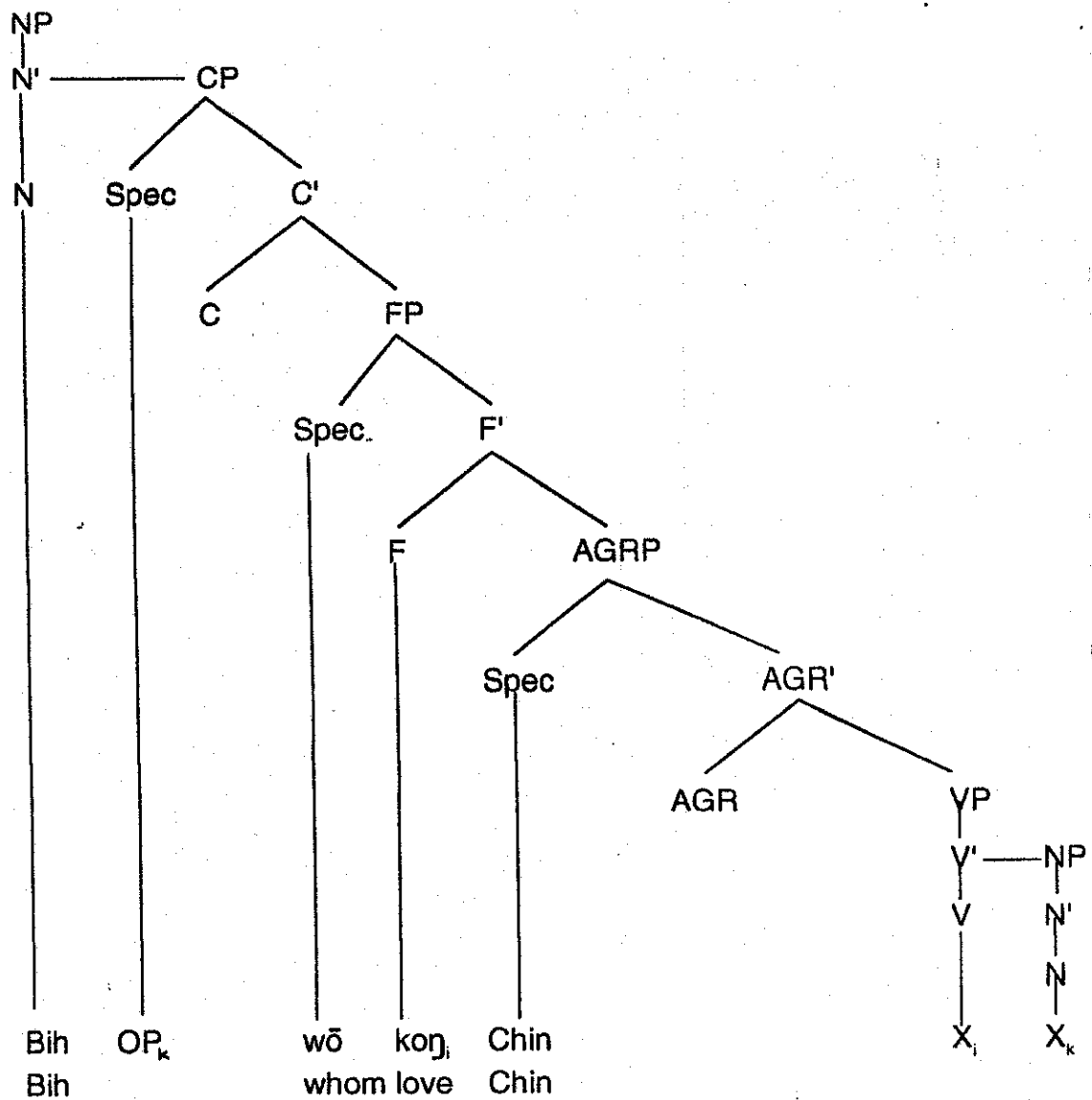

* 'The Bih whom it is Chin that loves'.

In (27a), the verb and its internal argument are generated in the base component. In (27b), verb movement applies and the verb is moved to the sentence-initial position. In (27c), another movement transformation applies moving the NP *Bih* to another position higher than the preposed verb position. Hence, it is the trace of the moved verb that is governing the trace of the moved NP.

4.3 THE ASSIGNMENT OF ACCUSATIVE CASE TO [SPEC, AGRP]

In the foregoing discussion, we have shown that the V-trace is active in that it has all the features of the moved verb. We have also argued, in Chapter Three, that

in Lamnso', some symbiotic relationship obtains between AGR and TNS. We said that AGR cannot occur without TNS and that when there is TNS, AGR appears automatically in respect of strict adjacency. We have, equally, shown that the verb moves with all the elements of the exploded INFL, with the exception of AGR. In this section, we will look at why AGR does not move and instead disappears after V-preposing. We will also look at the situation of the subject NP stranded by the disappearance of its case assigner. We provide evidence to show that a kind of "makeshift accusative case" is assigned to the loose NP.

4.3.1 THE DISAPPEARANCE OF AGR

Consider (28) :

- (28) a. Kimbáŋ (ki yí_kôŋ Bih
 white man AGR TNS love Bih
 'The whiteman will love Bih'
- b.* yí_kôŋ Kimbáŋ ki__Bih
 TNS love whiteman AGR Bih
 'It is the whiteman who will love Bih'
- c. yí_kôŋ Kimbáŋ__Bih
 TNS love whiteman Bih
 'It is the whiteman who will love Bih'

In (28b), TNS and the verb have been moved but the sentence is ungrammatical because *ki* in the AGR-node is still present. Inversely, in (28c), the sentence is grammatical because AGR has disappeared. Three questions can be asked following this phenomenon:

- (i) Why does AGR not move as other elements of the exploded INFL such as NEG and TNS?
- (ii) Why does it disappear instead?
- (iii) What are the consequences of its disappearance on [spec,AGR]?

The answer to the first question could be that there is a strict constraint on the directionality of agreement in Lamnso', so that, even at S-structure, spec-head agreement may only be to the right. Agreement will, therefore, not move as in the English sentence below:

- (29) a. John has a car
 b. Has John ___ a car?

In English, AGR and TNS constitute one bundle called INFL. They do not belong to different nodes as it is the case in Lamnso'.

Certain arguments could be advanced to account for the disappearance of AGR. If AGR is deleted because TNS has moved, then there is some strict adjacency requirement that obtains between the two elements. This is borne out because, in the language, no element may intervene between AGR and tense. The AGRP takes a TP-complement. The question is why the T-trace unlike the V-trace discussed above, fails to form a chain with the antecedent so as to satisfy the adjacency requirement? The extracted TNS cannot form a chain with its trace because we said that, at S-structure, following the morphological principle stated in (20) above and given the strong features of the verbal affix in Lamnso', the verb and tense become syntactically dependent. The trace is, therefore, not active enough to form a chain. Coindexation is impossible and as a result AGR disappears.

4.3.2 SUBJECT NP AND ACCUSATIVE CASE

NOT clear!

One very interesting phenomenon that results from V-preposing is that the subject NP is assigned accusative case. In Lamnso', nominative case is assigned by AGR which maintains a strict symbiotic and adjacent relationship with TNS. This could be stated formally as (30) below :

(30) NP is nominative in Lamnso' iff AGR and TNS are adjacent.

The generation and / or presence of AGR is, therefore, very crucial for subject NPs in Lamnso'. The condition for its generation is the presence of TNS, that is, in finite clauses. If we agree with Koopman (1984:142) that V-movement occurs prior to S-structure, that is, before the case component of grammar is activated at S-structure; if we consider the argument above that AGR disappears when the verb moves with TNS, then the subject NP assigned a theta role of agent at D-structure will be caseless at S-structure. Such caseless NPs are always ruled out in sentence structure by the case filter which stipulates that all NPs must be assigned structural case. The subject NP-position becomes invisible because, though it is theta marked by the verbal trace of the moved verb, it is not assigned case. The next thing is that other potential case assigners will now compete to assigned case to this NP so as to satisfy the case filter. Consider (31a) and its tree diagram representation in (31b):

(31) a. yí_kôŋ Kimbáŋ__Bih

b.

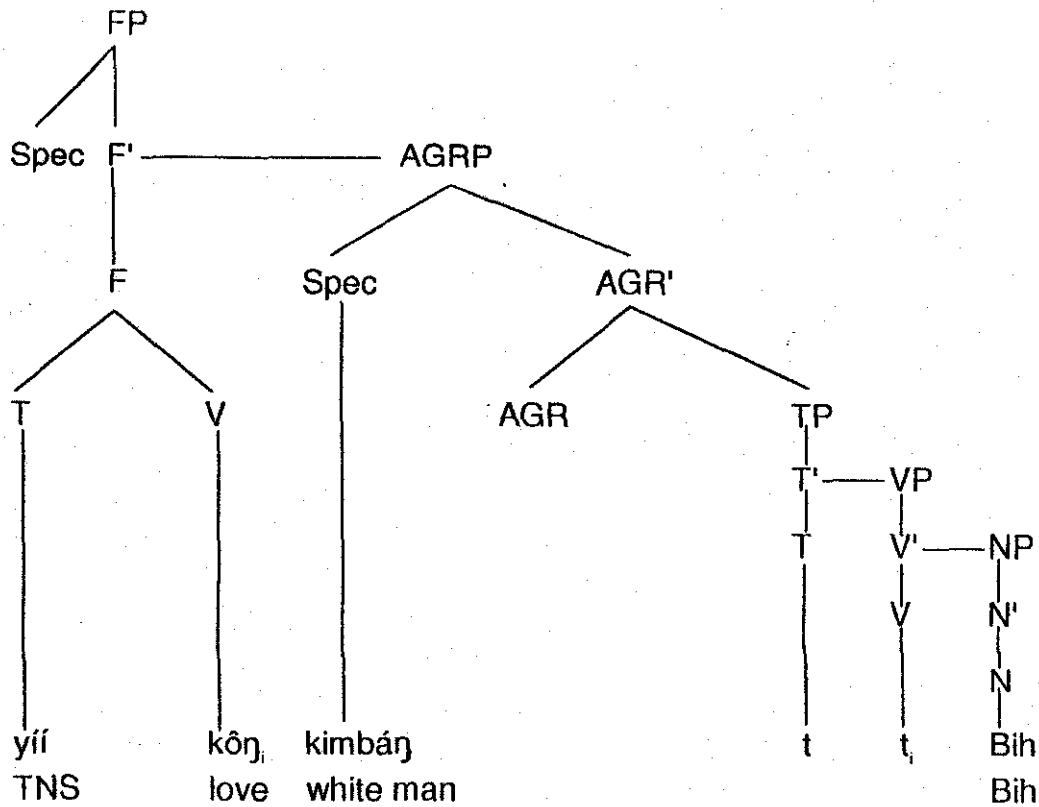

'It is the white man who will love Bih'.

(31b) shows that the nearest potential case assigner that can assign case to the NP in [spec,AGRP] is the verb in the F of FP. This satisfies the minimality condition on government since AGRP is not a barrier for outside government or since its governing domain has been weakened by the deletion of AGR, its head. But, what kind of case is assigned to the subject NP by the verb? Consider (32) below where morphological case is assigned to the subject position :

(32) a. m ∅ yíí_kôŋ Bih
 I AGR TNS love Bih
 'I will love Bih'

b. yíí_kôŋ,
TNS love me Bih
 mō t,
 me Bih
 'It is I who will love Bih'

(33) Chin kôŋ mō
 Chin love me
 Chin loves me

In (32b), the subject NP is assigned accusative case as it is verifiable from the morphological properties of *mō* 'me' (shown in (33)) as opposed to nominative *m* 'I'. The assignment of accusative case is logical because verbs can only assign

accusative to the right to their internal arguments. The above phenomenon raises a number of questions :

- (i) The V-trace is assigning case by forming a chain with the antecedent verb. The verb still assigns case to another NP in [spec,AGRP]. Then, to how many NPs can a single verb assign the same case :
- (ii) What status (argument structure) does a verb need to be able to assign such a case ?

A verb naturally assigns case to its internal arguments. But, in (32b) above, structural case is being assigned by the verb to an external argument. It is clear that the kind of case assigned to the subject NP is independent of theta role assignment which occurs at D-structure. Consider (34) below :

- (34) a. wu dû
 he go
 'He is going'.
 b. dû wūn ---
 go him
 'It is he that is going'.

The verb in (34a) is a one-predicate verb, that is, it has no internal argument. Yet, in (34b), it assigns accusative case to the subject NP when it is preposed. This shows that *kôj* 'love' in (32b) does not assign accusative case because it is originally a two-predicate verb and can assign that kind of case to the right. This is further buttressed up by (35) and (36) below where a verb assigns locative case (no preposition appears between the verb and the adjunct of place) in Lamnso' :

- (35) a. m dû way
 I go market
 'I am going to the market'.
 b. dû mō - way
 go me market
 'It is I who am going to the market'.
(36) a. Chin wîy way
 Chin come market
 b. wîy Chin - way
 come Chin market
 'It is chin who has come to the market'.

If this kind of accusative case were assigned depending on the argument structure of the verb, one would naturally expect that, in (34b), locative case be assigned to *m* 'I' and not accusative case. We, therefore, conclude that this kind of case assignment is independent of the argument structure of the verb that assigns it. It could be the case that the theta and/or case grid of the verb changes with its position, that is, depending on configuration. Hence, when the verb is moved to sentence-initial position, it has an additional argument added to its original grid.

In the literature on case assignment, it is said that a case assigner cannot assign the same case to two NPs or assign two kinds of case to the same NP. If the case assigned to the subject NP above is independent on the condition for case assignment (except government) then, it is some special kind of case assignment.

One interesting phenomenon in Lamnso' that has to be related to the present discussion is the fact that the language has not got pronouns with the features [+ pronominal, - animate, + accusative]. This means that in the language, personal pronouns that are inanimate cannot be generated in object position. Consider (37) below :

- (37) a. Chin fó kibán í mō
 Chin give fufu to me
 'Chin is giving fufu to me'.
 b. Chin fó pro í mō
 Chin give to me
 'Chin is giving it to me'.
- (38) a. Chin fó wan í mō
 Chin give child to me
 'Chin is giving the child to me'.
 b. Chin fó wun í mō
 Chin give him to me
 'Chin is giving him to me'.

In (37b), the object position is left empty because it has to be an objective pronoun. In (38b), the very position is filled by *wun* 'him' because *child* is animate. In the literature, such gaps, recoverable here by context, are filled by small *pro*. The question one could ask is how the case assignment discussed above is carried out for subject pronouns, that is, how can a subject pronoun with the feature [- animate] be assigned that kind of case given that no accusative pronouns exist in the language with that feature. Consider (39) below :

- (39) a. kicí ki bû
tree AGR fall
'The tree is falling'.
- b. ki bû
it fall
'It is falling'.
- c. * bû kí__
fall it
'It is it that is falling'.
- d. bû ki - wun
fall it him
'It is it that is falling'

(39c) is ungrammatical because the pronoun *kí* 'it', a subject pronoun with nominative case, has not been assigned accusative case. (39d) is grammatical because a pronoun with the feature [+animate] (*-wun* 'him') has been added to the original [-animate] pronoun, thereby 'animalizing' it. That is, it gives it animate qualities. This process of 'animalisation' of an inanimate pronoun (where *ki* becomes *kiwun*) is used to fill a gap in the language; the lack of inanimate objective pronouns.

4.4 V-PREPOSING AND SUBJACENCY

Does the verb that is preposed respect subjacency? consider (40) below :

- (40) a. [_{AGRP} kimbánj ki [_{VP} kôŋ Bih]]
white man AGR love Bih
'The whiteman loves Bih'.
- b. [_{CP} [_{VP} kôŋ]_i [_{AGRP} kimbánj [_{VP} t_i Bih]]]
love whiteman Bih
'It is the whiteman who loves Bih'.

In (40b), the verb *kôŋ* has moved from its base position in the sentence to FP at sentence-initial position. By so doing, it crosses only one AGRP and does not go over CP. Verb movement, therefore, respects Subjacency because the preposed verb is subjacent to its trace. (41) throws more light on this.

- (41) a. m ta' dzi Chin kôŋ Bih
I want that chin love Bih
'I want that Chin should love Bih'.

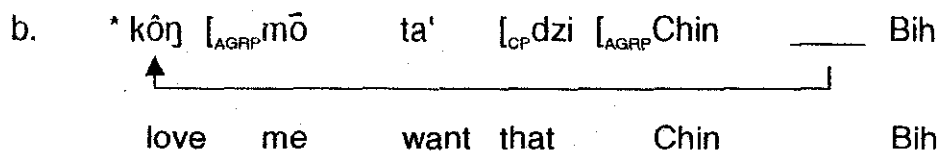

In (41b), the verb crosses two boundaries. Though there is the so-called bridge verb, the sentence is not grammatical. Not only is Subjacency violated but also the functional aspect of V-movement is violated, given that verb movement is to put the NP it precedes into focus. We, therefore, conclude that verb movement for clefting in Lamnso' cannot cross two AGRPs or a CP. Hence, it is strictly a local transformation since the verb cannot go very far.

4.5 SUMMARY

This chapter has explored sentence structure in relation to clefting in Lamnso' by linking it to some existing theoretical assumptions formulated in other natural languages. About the landing site of preposed verbs, we have argued that since the verb comes before a subject NP in order to put it in to focus and therefore assigns or discharges the function, FOCUS, to the NP, the pre posed verb could be consider to play the role of a focus word. Hence, the verb lands in the F of FP. We have also argued that the CP, unlike in Tuki, plays its traditional function in Lamnso'; that of hosting fronted WH-elements and relative operators and that this is why V-movement and WH-movement can co-occur because they have different landing sites. As concerns the elements that accompany the preposed verb, it has been shown that since tense is strongly bound to the verb and cannot be stranded, both elements move together and land in one place forming a split segment-category. Another accompanying head, NEG, cannot also be stranded by verb and tense and cannot also move alone. We have concluded that the verb adjoins to tense and both heads adjoin to NEG and then all of them move to sentence-initial position.

It has also been seen that the V-trace is active because the preposed verb in the derived position forms a chain with the trace it leaves at the base position. The trace, therefore, assigns case and even head-governs other traces such as the trace of relativised object NPs. It has also been demonstrated that the only I-property that does not move with the verb is AGR which is deleted instead. We have demonstrated that the disappearance of AGR is due to the fact that TNS has moved and that the consequence on the subject NP is the lack of a nominative case assigner at S-

structure. Hence, a kind of 'makeshift' accusative case is assigned to the subject NP just to let it satisfy the case filter. It has also been demonstrated that the assignment of this kind of case is independent on the argument structure of the preposed verb and could be due to the modification of the case grid of the verb depending on configuration. Finally, we have concluded that V-preposing respects Subjacency because it cannot cross two AGRPs or move over a CP. The transformation is local for the verb cannot go very far even when there is the so-called bridge verb.

GENERAL CONCLUSION

5.1 SUMMARY OF FINDINGS

Clefting in Lamnso' involves two processes : the movement of the verb to sentence-initial position and the occurrence of the copula in the sentence. About the movement of the verb, it has been established that the verb moves to a head position called the F of FP where it plays the role of a focus word. Hence, it assigns the function of focus to the subject NP it precedes. There are no restrictions for the kind of verb that can be preposed. Transitive, intransitive, distransitive and causative verbs can be preposed to the F-position of FP. The verb does not move alone. It moves along with other heads of the exploded INFL that precede it to the left such as NEG and TNS. The movement of the V-head respects Travis' head movement constraint and Chomsky's economy principle because the verb first adjoins to the T of TP; then both heads adjoin to another head position, NEG, before the whole load is moved to sentence-initial position. Under the F-node, they form what has been called the split-segment. The only element of the exploded INFL that does not accompany the preposed verb is AGR. It disappears and because of this disappearance, a kind of 'makeshift' accusative case is assigned to [spec, AGRP] by the moved verb whose case grid changes with the change in configuration.

There is also an active V-trace in the base position vacated by the moved verb. It has been demonstrated that the V-trace is properly governed by forming a chain with the antecedent verb. The active V-trace can also head govern the trace of relativised V-complements. This is because V-movement and relativisation can occur simultaneously or successively to the same kernel sentence. The relative operator lands in the spec of CP and the moved verb lands in FP. It is also possible to have the verbs of both matrix and embedded clauses preposed simultaneously albeit to different positions. In such a case, the lexical complementizer introducing the embedded clause is generated under the C-node of CP and the moved verb lands in the F-node of FP. There is, therefore, no conflict between the landing sites of the two moved elements at sentence-initial position. It has also been shown that V-movement

respects Subjacency because it is essentially a local transformation that cannot go very far. Two AGRPs cannot be crossed because the functional status of V-movement, which is to put the subject NP into focus, will be violated.

As for the occurrence of the copula, it has been noted that, this is typically used for focusing at their base positions V-complements such as object NPs, embedded IPs, that-complements and PPs. Subject NPs can also be focused using the copula with a lot of restrictions since relativisation must first take place. The copula can also appear in sentence-initial position in order to focus relativised V-complements with the exception of IPs, PPs, and CPs which cannot be moved to sentence-initial position. Semantically, this leads to a slight shift in meaning. The moved indefinite noun becomes a definite noun. Another difference between the occurrence of the copula at base and at sentence-initial position is that the copula at base takes an expletive *a 'it'*. On the contrary, the copula at sentence-initial position takes no expletive. Though there is no overt expletive, there is *pro*. The fact that the sentence-initial copula has an empty subject position and the fact that the verb moves in front of the subject NP has led us to conclude that the formula for clefting in Lamnso' at sentence-initial position is

V XP

Where XP is any phrasal constituent (fronted or in situ) that is focused.

5.2 V-PREPOSING, THE OCCURRENCE OF THE COPULA AND UNIVERSAL GRAMMAR

Clefting is an element of Universal Grammar. It is used by speakers of natural languages to show the constituents of a sentence on which emphasis is laid. This is the case with the speaker of Lamnso'. Like in English, clefting in Lamnso' involves move alpha. What ever is moved (the verb in Lamnso' and the noun in English) respects Subjacency. The vacated base position also contains a trace that is co-indexed with the antecedent. The clefting of certain constituents in Lamnso' also requires the generation of *a dze* or *pro dze* in front of the constituent in question which is similar to the English 'it is'.

5.3 PARAMETRIC VARIATIONS

Compared with English, Lamnso' seems to have some processes for clefting that are peculiar. The focusing of an element does not necessarily require that the element be moved. The focused element remains in situ. Then the verb moves (for cases of subject NPs) and the copula is generated in front of the clefted element (for the case of post-verbal-phrasal categories). For this reason, post-verbally embedded phrases such as the IP and the CP which cannot be clefted in English (except for certain pseudo-cleft constructions) are cleftable in Lamnso'. A copula is simply generated between them and the verb in the matrix clause. Also peculiar to Lamnso' is the fact that the subject position of the copula generated at sentence-initial position is empty. The assignment of accusative case to [spec, AGRP] is equally interesting. This results from the change of the case grid of the preposed verb that results from the change of configuration.

Another language specific phenomenon in Lamnso' is the fact that a trace can govern another trace. This means that two movement transformations can apply successively with the same clause. Hence, after the verb has been preposed, its complement can still be relativized. Such operations are ruled out in English by the doubly filled COMP (DFC) filter but are licensed in Lamnso' because, given the co-existence of a COMP position and another phrasal category (which we called FP), there is no conflict of landing site.

5.4 PROSPECTS FOR FURTHER STUDY

It has been demonstrated in this study that a kind of 'makeshift' accusative case is assigned to [spec, AGRP] after the verb has been preposed and AGR has disappeared. Case has been hypothesized to be assigned at S-structure but this kind of case is assigned after the verb has assigned its 'natural' case to its internal arguments. It will, therefore, be useful to determine in future research work at what syntactic level this case is assigned. This study could be extended to other Bantu languages such as Bafut where a similar phenomenon occurs to bring out similarities and dissimilarities.

It will also be a useful effort to probe into the relationship between clefting and WH-movement as observed in Lamnso' and some Grassfield Bantu languages. The question will be to explain why clefting is used to move WH-phrases.

BIBLIOGRAPHICAL REFERENCES

- Alexandre, P.** (1972). *An Introduction to Languages and Language in Africa*. Translated by Leary, F. A. London : HEB.
- Bach, E.** (1973). *Syntactic Theory*. Cambridge : CUP.
- Bilola, E.** (1995). *Functional Categories and the Syntax of Focus in Tuki*. München; Lincom Europa.
- Chem-Langhèè, B. and V. G. Fanso** (1997). "Social Categories, Local Politics and Uses of Oral Tradition in Nso Cameroon". Colloque International, Université de Provence, Publications de l'Université de Provence.
- Chomsky, N.** (1965). *Aspects of the Theory of Syntax*. Cambridge, MASS : MIT Press.
- _____ (1977). *Essays on Form and Interpretation*. New York : Elsevier.
- _____ (1981). "Principles and Parameters in Syntactic Theory". In Hornstein, N. and D. Lightfoot (1981) (eds). *Explanation in linguistics*. PP. 123-146.
- _____ (1986). *Barriers*. Cambridge, Mass : MIT Press.
- Daly, J.; L. Lyman and M. Rhodes** (1981). *A course in Basic Grammatical Analysis*. University of North Dakota : SIL Cameroon.
- Haegeman, L.** (1984). *Introduction to Government and Binding Theory*. Oxford : Blackwell Publishers.
- Koopman, H.** (1984). *The Syntax of Verbs. From Verb Movement Rules in the Kru Languages to Universal Grammar*. Dordrecht : Foris Publication.
- Lyons, J.** (1987). *An Introduction to Theoretical Linguistics*. Cambridge : CUP.
- Peck, C.** (1995). *How to analyse a Language*. Dallas : SIL.
- Pollock, J. Y.** (1989) 'Verb Movement, UG and the Structure of IP' *Linguistic Inquiry*, 20, 365 - 424
- Quirk, R. and S. Greenbaum** (1987). *A University Grammar of English*. Hongkong : Longman. (67)
- Radford, A.** (1981). *Transformational Syntax : A Guide to Chomsky's Extended Standard Theory*. Cambridge : CUP.
- _____ (1997). *Syntactic Theory and the Structure of English : A Minimalist Approach*. Cambridge : CUP.

Check
Trans

Riemsdijk, H. V. and E. Williams (1986). *Introduction to the Theory of Grammar*.

Cambridge, Mass : MIT Press.

Rizzi, L. (1990). *Relativized Minimality*. Cambridge, Mass : MIT Press.

UNPUBLISHED WORKS

Grebe, K. (1976). "The Phonology of Lamnso". SIL Cameroon.

_____ (1984). "The Domain of Noun Tone Rules in Lamnso". Unpublished M. A. Thesis, University of Calgary.