

INFORMATION STRUCTURE IN ACADIAN FRENCH

by

Emma Pavey
Bachelor of Arts, University of Sussex, 1995

A Thesis

Submitted to the Graduate Faculty

of the

University of North Dakota

in partial fulfillment of the requirements

for the degree of

Master of Arts

Grand Forks, North Dakota

August

2001

Copyright 2001 Emma Pavey

TABLE OF CONTENTS

LIST OF FIGURES	iv
LIST OF TABLES	iv
ACKNOWLEDGEMENTS	v
ABSTRACT	vi
SECTION	
I INTRODUCTION	1
II REVIEW OF STUDIES OF DETACHMENT STRUCTURES IN FRENCH.....	3
III INTRODUCTION TO THE DATA	6
3.1 Detached Noun Phrases	6
3.2 Detached Prepositional Phrases and Verb Phrases	6
IV ROLE AND REFERENCE GRAMMAR ANALYSIS	9
4.1 Outline of Role and Reference Grammar – the Layered Structure of the Clause	9
4.2 Information Structure	11
V FRENCH	15
5.1 Cleft Structures	15
5.1.1 Presentational ya Cleft	15
5.1.2 Identificational c’est Cleft	16
5.2 Left Detachment Structures	18
5.2.1 Use of ce as Anaphor	19
5.2.1.1 Ça c’est Construction	26
5.2.1.2 NP c’est que Construction.....	27
5.2.2 ‘No Anaphor’ LD Structures	30
5.2.2.1 Subtypes of LD Sentences with No Anaphor.....	32
5.2.3 ‘Case Study’: First and Third Person Plural Pronouns	34
5.3 Right Detachment Structures	39
5.3.1 RDs are Syntactically Allied to the Main Clause	39
5.3.2 RD Constituents Cannot be ‘Unlinked’	39
5.3.3 Syntactic Structure of RD Sentences	40
5.3.4 Position of RDP in Sentence – Interaction of Syntax and Information Structure	41
5.3.5 Intrasentential Pronominal Coreference	46
5.3.6 Other Discourse Factors – Comparison with LD	47
5.4 Left Detachment and Right Detachment in the Same Sentence	49
VI CONCLUSION	51
REFERENCES	53

LIST OF FIGURES

Figure		Page
1	Formal Representation of the Layered Structure of the Clause (LSC).....	9
2	Japanese Example Demonstrating Layered Structure of the Clause.....	10
3	Abstract LSC Including Extra-Core Slots and Detached Positions	10
4	LSC for English Sentence with Adjectival Predicate	11
5	LSC for Sentence 1:3:192 from St Pierre Data	11
6	The Cognitive States of Referents in Discourse.	12
7	Coding of Referents in Terms of Possible Functions	13
8	Formal Representation of Focus Structure (in Sentence 2:4:7).....	14
9	LSC for Sentence 4.3c.....	16
10	LSC for Sentence 4.4b	18
11	LSC for Sentence 1.1b	19
12	Focus Domain for Sentence 4.5a.....	22
13	LSC for Sentence 5.9e.....	24
14	LSC for Sentence 5.13b	29
15	LSC for Sentence 4.20c.....	34
16	RD Syntactic Structure, Proposed by Lambrecht (2001:25)	41
17	LSC for Sentence 1:3:82	41
18	LSC for Sentence 5.37a.....	44
19	LSC for Sentence 5.37c.....	45

LIST OF TABLES

Table		Page
1	Left Detached NPs in the Data	7
2	Right Detached NPs in the Data.....	8
3	Information Statuses of Lexical LD Referents with Subject Anaphors.....	24

ACKNOWLEDGEMENTS

I would firstly like to thank my thesis supervisor, Dr. Dan Everett, for his excellent help and encouragement with this thesis. Thanks are also due to the other members of my committee, Dr. Albert Bickford and Dr. Jim Meyer, for their valuable input. I am also most grateful to my friends in St. Pierre-Jolys, Manitoba, for their welcome and their willingness to assist me; particular thanks go to Raymond and Nicole Lavergne and Ariane Mulaire – merci beaucoup.

ABSTRACT

This paper examines aspects of information structure in Acadian French, focusing on the use of detached (also referred to as ‘moved’ or ‘dislocated’) syntactic structures in the spoken language. The data is from interviews with Acadian French speakers and is analyzed using Role and Reference Grammar as a theoretical framework. One section of this paper also reviews existing literature on the subject. This study is innovative empirically in that it studies a Canadian variety of French which has not been significantly discussed previously in the literature on information structure nor within the RRG model. The detached clauses are subdivided into different types and their use is described and analyzed. This paper not only helps us understand the means of encoding information structure in the grammar of Acadian French speakers of Canada; it also serves as a basis for comparison and historical development in information structure as other researchers compare the results and analysis obtained in my study with those of studies on other varieties of French.

SECTION I

INTRODUCTION

This paper examines an aspect of information structure in Acadian French of Manitoba, namely the use of detached (also referred to as ‘moved’ or ‘detached’) syntactic structures in the spoken language. Dislocation is defined as “a sentence structure in which a referential constituent which could function as an argument or adjunct within a predicate-argument structure occurs instead outside the boundaries of the clause containing the predicate, either to its left ...or to its right” (Lambrecht 2001:1). The following examples from the data illustrate this phenomenon:

- 1.1 a. Moi¹, j’suis de St Pierre. (1:2:71).
*Me, I am from St Pierre.*²
- b. Le printemps, il était venu tard. (1:3:196).
The spring, it came late.
- c. OK, i’est important, lui. (1:3:82).
OK, he’s important, him.

The data to be cited is from interviews with Acadian French speakers and will be analyzed using Role and Reference Grammar (RRG) as a theoretical framework. Following a review of existing literature on the subject, an overview of the data will be given. There is then a brief outline of Role and Reference Grammar, followed by a description of three of the syntactic structures in French which have a pragmatic function. This will set the context for a closer examination of the last of these: detachment constructions. Various types of detachment constructions will emerge and be analyzed in terms of Role and Reference Grammar theory.

This study is innovative empirically in that it studies a Canadian variety of French which, at this point, has not been significantly discussed in the literature on information structure nor within the RRG model. This study not only helps us understand the means of encoding information structure in the grammar of the Acadian French speakers of Canada, it also serves as a basis for comparison and historical development in information structure as other researchers compare the results and analysis obtained in this study with those of studies on other varieties of French.

This paper also elaborates on previous studies of French in terms of theoretical description. Specifically, the interconnection between pragmatics and syntax as they collaborate to convey information structure is examined in detail as it occurs in detachment constructions. Firstly the increasing use of the coreferring impersonal third person pronominal form **ce** in preference to the personal **il/elle** is discussed and connected to the frequent accompaniment of **ce** with the copula verb **être** – similarities are observed between the pragmatic use of this **c’est** following a left detachment structure (LD), and the so-called **c’est** cleft itself. Other observations are then made concerning other types of detachment construction containing **ce** and the copula **être**. This leads to a discussion of the cases of detached sentences with no syntactic anaphorical element in the

¹ The detached element is indicated with underlining.

² All translations retain the detached structure where it exists in the French, even when a little unnatural in English, to convey the French meaning. They also take some liberties with the conventions of written French, to convey the impression of the spoken form.

main clause and to comparison with the use of first person plural pronominal forms. Finally, attention turns to characteristics of right detachment structures.

SECTION II

REVIEW OF STUDIES OF DETACHMENT STRUCTURES IN FRENCH

As a background to the discussion of detachment constructions in terms of Role and Reference Grammar, it is helpful to examine previous studies of the topic and their theoretical approaches. Detachment (or dislocation) constructions, particularly to the left of the clause, are generally treated in the literature as topicalization structures whereby the detached element is established as the topic of the sentence. Beyond that agreement, studies of dislocation in general and as seen in French in particular, generally fall into two categories. In the first category are those which use transformational grammatical theory to account for these constructions from a syntactic perspective. As the name ‘dislocated’ suggests, most of these studies interpret this phenomenon as having been ‘moved’ from an original, underlying sentence. However, some suggest there to be two types of dislocated clause in French: one of these types is base-generated (‘hanging topic’) and the other is generated by movement of an element, predominantly the subject, and predominantly to the left of the clause (Hirschbühler 1975; Cinque 1977; Larsson 1979). Disagreement amongst followers of this approach tends to be over whether the evidence supports one or two types of dislocation structure in French.

Ross (1967) proposes the rule of Left Dislocation (given in 2.1 below) to account for detached structures.

2.1 Left Dislocation (Ross 1967:233-34, cited in Barnes 1985:5)

$$\begin{array}{ccccccc} X & - & NP & - & Y & \Rightarrow & 2\#[1 [2] 3] \\ 1 & & 2 & & 3 & & +PRO \end{array}$$

However, Hirschbühler (1975) subsequently shows that certain sentences in French cannot be derived by Ross’s rule of Left Dislocation; 2.2 (from Barnes 1985:5) gives examples of such detached sentences.

2.2 a. Paul, Pierre vient de se battre avec cet idiot.

Paul, Peter has just fought with the idiot.

b. Un espion, on reconnaît cela à son chapeau.

A spy, we recognize him by his hat.

The problem is in accounting, firstly, for different types of constituents as detached elements and, secondly, for different types of constituents as anaphor in the main clause. While the rule seems to account for left detached prepositional phrases, Hirschbühler proposes that left detached NPs with NP or PP anaphor in the main clause be generated as deep structures (Barnes 1985:6). Cinque (1977) expands on this theory by arguing for the two constructions as separate entities. However, as Barnes (1985:7) points out, Cinque’s description of the two types leaves ambiguous the placement of left detached sentences which do not exhibit all the required characteristics for membership in one of the two types. Larsson (1979) seeks to summarize the difference by the following explanation: “any lefthand [LD] element for which the corresponding righthand [RD] construction is grammatical [should] be considered to be derived, or at least derivable, by transformation, while any...without...[should] be considered basic” (Barnes 1985:7).

Given the difficulties apparent in a syntactic justification for positing two types of left detached structure, other studies approach the issue from a pragmatic or intonational perspective,

suggesting the base-generated ‘hanging topic’ to be more contrastive, introducing a new topic, and to be phonologically marked with a pause and pitch rise (as outlined by Barnes 1985:8). This description of a pause, however, contrasts with other studies (such as Barnes 1985) which comment that, in modern spoken French, a pause is rarely, if ever, evident.

Betsy Barnes herself, in her 1985 study of the pragmatics of left detachment in spoken French, questions the justification for the division of detachment constructions in French into two types, arguing that such a categorization is without “empirical validity” (Barnes 1985:20). Rather than approaching her analysis from a transformational syntactic ‘movement’ perspective, Barnes looks at the information structure of the sentence and the context of preceding discourse to explain the occurrence of detachment constructions. In calling the function of LDs ‘comparative’, Barnes, in essence, observes the pragmatic generalization that LDs carry out a special kind of topic shift where the new topic is still somewhat related to the previous topic (1985:22).

In a later study which once again seeks to understand the link between pragmatics and syntactic form, Pierre Cadiot (1992) examines dislocation in French in terms of features; he seeks to discover the connection between these syntactic forms “specifically associated with topichood” (1991:57) and pragmatic constraints. He begins with a precise descriptive typology of six LD constructions using the [+/- CASE], [+/- PAUSE] and [+/- FUNCT] features. His study differs from some others as he includes ‘topicalization’ as an LD type ([-CASE], [+PAUSE], [-FUNCT]), though other studies (*e.g.* Lambrecht 2001) take pains to differentiate topicalization constructions from detached/dislocated constructions.

Other studies of dislocation which examine the construction from a pragmatic or discourse-oriented angle look at its use by speakers in communication contexts. This functional approach also emphasizes the role and influence of information structure, utilizing terms such as topic and focus in effectively describing and explaining dislocated sentences. The most prolific exponent of this type of analysis is Knud Lambrecht. His work on spoken French examines information structure and the syntactic constructions that interact with it. Lambrecht argues that the left detached construction is a second basic type of syntactic construction in French, along with SVO word order; this is argued in terms of attributes of LD sentences (Lambrecht 1980, 1981), by association with other pragmatically-influenced constructions (the presentational **ya** cleft and identificational **c’est** cleft; Lambrecht 1984, 1986) and also by comparison with the standard SVO word order (Lambrecht 1987). Lambrecht claims that, rather than looking solely at the status of clitics in French to determine the basic word order and how may be shifting, one should look at the subject/topic dimension; he argues that “N[ew] S[tandard] F[rench] is a simultaneously topic-prominent and subject-prominent language” (Lambrecht 1981:52) where the former refers to (left) detached sentences and the latter to the ‘traditional’ SVO constructions. The difference between these (in formal terms) is that “the former mark verb agreement [by way of clitic pronominal forms ‘attached’ to the verb] and the latter do not” (Lambrecht 1981:52). In contrast to the transformational approaches, which “analyz[e detached] sentences...as marked structures that ‘dislocate’ the ‘normal’ word order” (Lambrecht 1980:345), Lambrecht argues consistently that “it is simpler and intuitively more satisfying to consider [2.3a] an example of

one basic sentence type and to interpret [2.3b] and [2.3c] as two aspects of another, derivationally independent, basic pattern” (1980:345). The examples in 2.3 illustrate his point³.

- 2.3 a. Tu-manges les pommes.
 ‘*You eat the apples.*’
- b. Tu-les-manges.
 ‘*You eat them.*’
- c. Les pommes tu-les-manges.
 ‘*You eat the apples.*’ (Lambrecht 1980:344).

While most of the studies highlighted above have been concerned with the French of France, there have not been many studies undertaken of detachment structures in Canadian French. There are some studies which look at sociolinguistic aspects of French use in Canada (*e.g.* Deshaies 1981, Fox 1991) and some other structural aspects of Québécois French have also been examined (*e.g.* Auger 1995). Elizabeth Cowper’s short 1979 paper is one example of a study which does focus on dislocation in Canadian French. It uses a transformational theoretical approach and looks particularly at issues of pronominalization and coreference in right dislocated structures, but Cowper is hesitant in her conclusion. This study aims to fill a gap in the coverage of the literature surveyed here, in terms of its theoretical approach and also in terms of the type of French studied. The following section begins with an introduction to the data that forms the basis for the paper.

³ These examples retain Lambrecht’s transcription style, inserting hyphens between verbs and their accompanying pronominal elements.

SECTION III

INTRODUCTION TO THE DATA

The focus of this study is the French spoken in the town of St Pierre-Jolys, in Manitoba, Canada. St Pierre, as it is known, is located fifty-six kilometers south of Winnipeg. Its population of about 925 people consists largely of commuters (to Winnipeg) and farmers, as well as some local business people. The town, and a few others in the surrounding area, are largely monolingual French-speaking. While everyone has a generally good level of English, French is spoken in stores, in homes, on social occasions and in the French immersion school located in the center of the village. Many of the villagers' ancestors were Acadian French, from Québec. They were forcibly exiled from Québec by the English in 1755 and families were deliberately divided and sent to a variety of areas, including Louisiana (there known as 'Cajun') and the east coast of the (now) United States. When this period of enforced exile ended, many families sought to return to Canada and resettle. Some took the opportunity to head further west and a number eventually settled in Manitoba. Even then, they had to fight to preserve their cultural heritage. At the beginning of the twentieth century, the English-speaking government of Manitoba banned the teaching of French in Manitoba's public schools; the villagers I spoke to described how they were forced to teach French in secret, to be somewhat ashamed of their language. As a result, the inhabitants of St Pierre are now very proud of their ethnolinguistic heritage and there are several cultural events during the year that reflect this. They have learned from their history not to take their language rights for granted; as a result, French has a strongly predominant position in the village. However, it is also true that the speech of the children of St Pierre often contains a few English words; these are mostly interjections, but occasionally are also content words for which they forget the French word or prefer the English word, e.g. *C'est l'fun* (1:1:34).

I visited St Pierre in April of 2001 and recorded approximately an hour and a half of different types of speech, ranging from individual narratives to informal conversation in a group. Different types of people, in terms of age, gender, and social status, are represented in the data, although all the contributors are from St Pierre itself and consider French their first language (mother tongue). The following subsections give an overview of the data gathered.

3.1 Detached Noun Phrases

Twenty right detached phrases and eighty-one left detached phrases were found in the data. The vast majority of these involved detached noun phrases (NPs). The detached NP constructions can be subdivided, using a table adapted from Barnes 1985, by type of detached NP and the function of the anaphoric expression in the main clause. Tables 1 and 2 show the occurrence of left detached and right detached phrases respectively, in the St Pierre data.

3.2 Detached Prepositional Phrases and Verb Phrases

In addition to the detached noun phrases, a few detached phrases of other types are present in the data. One left detached verb phrase (3.1a) and one right detached verb phrase (3.1b) were found, as well as one left detached prepositional phrase (3.1c).

Table 1: Left Detached NPs in the Data

Anaphoric expression (grammatical function)	Detached NP type					
	Pronominal		Lexical NP		Combined	
	#	% of Pro	#	% of NP	#	% of total
Subject, total	32	80.0	32	78.0	64	79.0
+ personal	17	42.5	22	53.7	39	48.1
1sg	7	17.5			7	8.6
other	10	25.0	22	53.7	32	39.5
- personal	15	37.5	10	24.4	25	30.9
D.O.			5	12.2	5	6.2
I.O.						
Oblique						
No anaphor, total	8	20.0	4	9.8	12	14.8
moi...	5	12.5			5	6.2
nous-autres...	1	2.5			1	1.2
eux-autres...	1	2.5			1	1.2
ça...	1	2.5			1	1.2
Total	40 (49.4%)		41 (50.6%)		81	

- 3.1 a. Ça fait que j', j'en, je le transforme ici au lieu parce qu'en fait venir de Québec, ça prends trop de temps, t'sais là. (2.2.12-13).
That means that I, I, I convert it here on the spot because to get some sent from Québec, that takes too much time, you know.
- b. Moi, j'aime ça, vivre à St Pierre, p'ce que...euh c'est pas, euh, si gros, ça fait q'tu, tu peux faire plus de choses... (1.1.6).
Me, I like that, to live in St Pierre because...uh, it's not, uh, so big, what I mean is that you, you can do many things...

Table 2: Right Detached NPs in the Data

Anaphoric expression (grammatical function)	Detached NP type					
	Pronominal		Lexical NP		Combined	
	#	% of Pro	#	% of NP	#	% of total
Subject, total	11	91.7	8	100.0	19	95.0
+ personal	8	66.7	3	37.5	11	55.0
1sg	4	33.3			4	20.0
other	4	33.3	3	37.5	7	35.0
- personal	3	25.0	5	62.5	8	40.0
D.O.						
I.O.						
Oblique						
No anaphor, total	1	8.3			1	5.0
moi...	1	8.3				
nous-autres...						
ça...						
Total	12 (60%)		8 (40%)		20	

c. Oui, je viens de St Pierre, mais ça ici c'est juste un village pour nous, pis là en ville, c'est Winnipeg. (1:1:14).

Yes, I come from St Pierre, but this here is only a village for us, but there 'in town', it's Winnipeg.

SECTION IV

ROLE AND REFERENCE GRAMMAR ANALYSIS

4.1 Outline of Role and Reference Grammar – the Layered Structure of the Clause

In addition to an overview of the data, an outline of Role and Reference Grammar is needed before the analysis can be presented. Role and Reference Grammar is a single-level theory (*i.e.* no ‘underlying’ level) which sets out the universal layered structure of clauses (LSC) as containing a core with an optional periphery. In the core are the required nucleus, which is the predicate, and optional arguments of that predicate. The periphery, which can be in any linear position relative to the nucleus and arguments, contains elements which are not arguments of the predicate (*e.g.* location PP or ADV) (Van Valin & LaPolla 1997:26, 30). This is illustrated below in Figure 1:

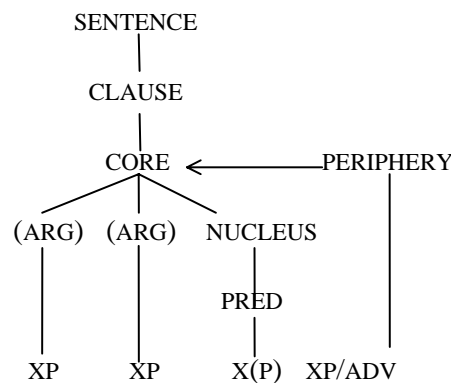

Figure 1: Formal Representation of the Layered Structure of the Clause (LSC). (Van Valin & LaPolla 1997:31)

The example of a sentence of Japanese, using this type of analysis, in Figure 2, clearly illustrates the lack of a set linear order for the universal constituents in the layered structure of the clause (LSC) – this ability to allow lines to cross will be significant for the analysis of detached phrases in French.

In addition to these universal elements, Role and Reference Grammar also allows for four non-universal components whose linear order is relevant. Left and right dislocated phrases are termed ‘detached’ to avoid the implication of movement and are assigned to left detached position (LDP) and right detached position (RDP) respectively, outside the main clause.

The post-core and pre-core slots are inside of the clause but outside of the core and may contain such items as WH-words. Figure 3 shows all these components and their linear relation to the core (periphery omitted).

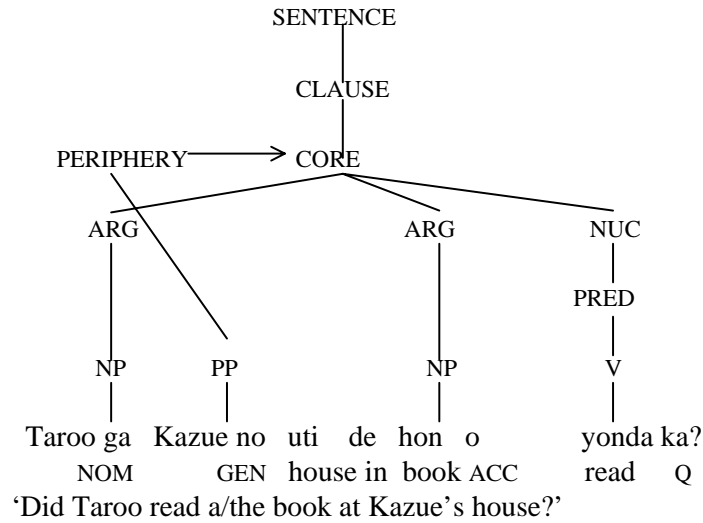

Figure 2: Japanese Example Demonstrating Layered Structure of the Clause (Van Valin & LaPolla 1997:32)

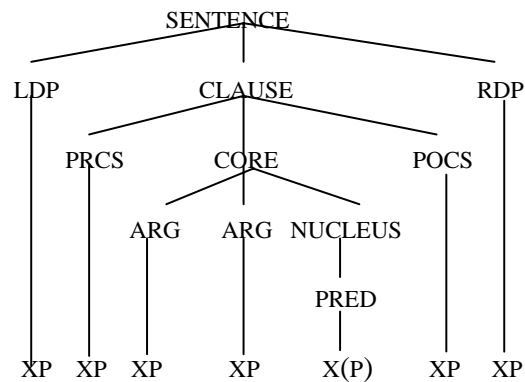

Figure 3: Abstract LSC Including Extra-Core Slots and Detached Positions (Van Valin & LaPolla 1997:38)

Another aspect of Role and Reference Grammar theory which is important for the analysis in this paper is that not all the elements in the sentence are part of the syntactic LSC structure. Elements in the sentence that represent operators modifying the clause and its parts in terms of tense, aspect, modality and so on, are not represented in the syntactic part of the LSC structure. Significant for this study is that this can include non-predicative verbs. Thus, the syntactic structure for a sentence where the predicate is an adjective, for example, would be diagrammed as follows:

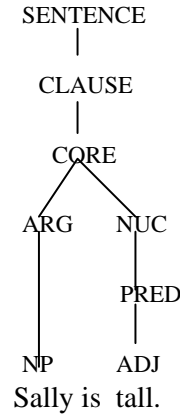

Figure 4: LSC for English Sentence with Adjectival Predicate (Operator Projection Omitted) (Van Valin & LaPolla 1997:51)

Applying these types of structures to detachment constructions in French is quite straightforward. Figure 5 illustrates the layered structure of a detached sentence from the St Pierre data. This example has both a left detached element and a right detached element (which, in this case, corefer with different arguments of the predicate).

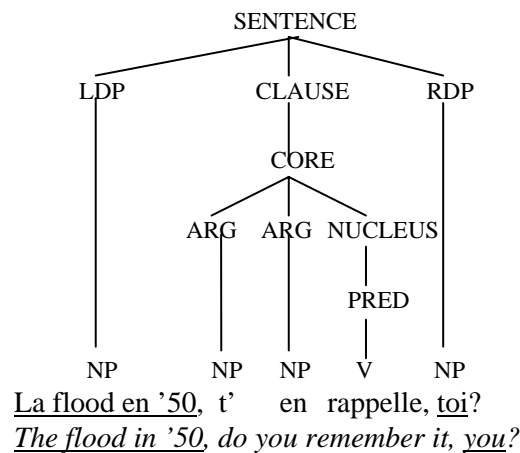

Figure 5: LSC for Sentence 1:3:192 from St Pierre Data

What is significant, especially in the analysis of detachment constructions in French, is that there is an important difference between the universal and non-universal elements in the sentence: while there is semantic motivation for the universal aspects, “non-universal aspects (the detached phrases, the extra-core slots) are not semantically motivated; rather, they seem to be pragmatically motivated (or at least are associated with constructions that have strong pragmatic conditions on their occurrence” (Van Valin & LaPolla 39-40). These pragmatic conditions are part of the information structure of the sentence.

4.2 Information Structure

The interpretation of information structure in Role and Reference Grammar owes a great deal to the recent work of Knud Lambrecht. It seeks to elaborate on the pragmatic relation between

presuppositions and referents and, to this end, divides referents into different types (following Lambrecht) according to their position in the hearer’s consciousness. It is assumed that speakers use their awareness of the hearer’s consciousness to the best of their ability in deciding which form to use. The types are as follows:

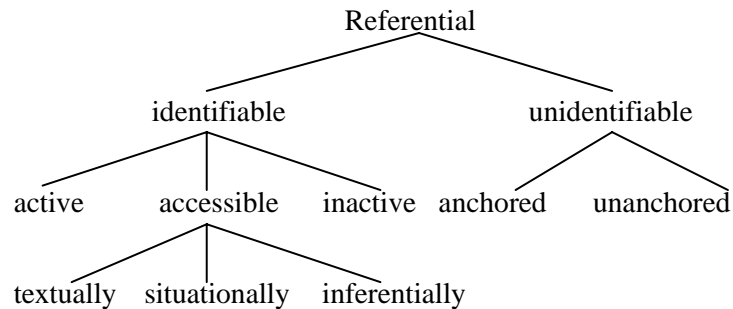

Figure 6: The Cognitive States of Referents in Discourse (Van Valin & LaPolla 1997:201)

As mentioned briefly above, what is informatively significant in each sentence is not the referent(s) in isolation, but the effect of a combination of ‘old’ and ‘new’: the context of the old assumptions (the presupposition) and the addition of new information related in some way to those assumptions (Van Valin & LaPolla 1997:201-2). The ‘topic’ is the referent in the presupposition that “has the [pragmatic] function of naming the referent that the assertion is about” (203).

The status of an element as topic also depends, as the definition above implies, on the role it plays in the sentence. Gundel (1988) uses this approach to define ‘topic’: “An entity, E, is the topic of a sentence, S, iff in using S the speaker intends to increase the addressee’s knowledge about, request information about, or otherwise get the addressee to act with respect to E” (cited in Lambrecht 2001:25). In both these definitions, (and others, e.g. Barnes 1985, Reinhart 1982), the activation status of a topic is connected to, or implied by, its purpose in the sentence, rather than being a part of the definition itself.

However, since the hearer must have an awareness of the referent of the topic before something new can be said about it, a hierarchy does exist which places the cognitive states of a referent alongside their acceptability as a topic: an active referent is most likely to be acceptable as a topic, since it can safely be assumed by the speaker to be available to the mind of the hearer. On the other hand, an unidentifiable, unanchored referent will be less likely to be accepted, and perhaps unsuccessful if used as a topic in a presupposition (Lambrecht’s Topic Accessibility Scale, cited in Van Valin & LaPolla 1997:204). In fact, in referring to overtly topic-marked elements in a sentence, Lambrecht states, “the referent of the topic expression must be identifiable for the speaker. One cannot assess a predication relative to a given topic unless one knows what the topic entity is” (Lambrecht 2001:25). This excludes referents from the ‘unidentifiable’ side of the tree in Figure 6 above. Lambrecht gives the following example from Japanese as evidence:

- 4.1 **Neko wa** kingyo o ijitte.
 cat top goldfish obj play.with
 ‘The/*A cat is playing with the/a goldfish.’ (Lambrecht 2001:26).

In other words, unidentifiable referents may be ordinarily acceptable as topics in a sentence. However, if a topic-marking element or construction is used, such as the **wa** item in the Japanese example in 4.1, or a detachment construction, unidentifiable referents are excluded.

This hierarchy of topic accessibility corresponds to a scale of coding of those referents which ranges from an indefinite NP to zero coding.

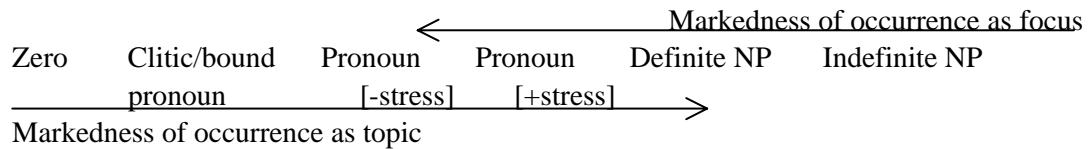

**Figure 7: Coding of Referents in Terms of Possible Functions
(Van Valin & LaPolla 1997:205)**

Zero coding is the least marked way of coding a topic, whereas using an indefinite NP would be the most marked method of coding a topic. The situation is reversed for the focus, the asserted part of the sentence.

At the discourse level, “that thing which a segment of discourse larger than the sentence is about” (Barnes 1985:28) is the discourse topic, as compared with the sentence topic which is discussed above. With regard to detached constructions, Lambrecht writes that a LD or RD referent must “have a degree of salience or topicality in the present discourse” (2001:26). This would seem to correspond to what others call discourse topic.

In Role and Reference Grammar, the cognitive state of the referent (as accessible, unidentifiable, etc.) is determined by the discourse and is encoded at the sentence level. However, the recognition described above, of two types of topic, (topic of the sentence (sentence topic) and topic of the discourse (discourse topic)), which is useful in accounting for LD/RD structures, is not made explicitly in Role and Reference Grammar.

Moving from topic to focus, the asserted part of the sentence, there are three types of focus structure in Role and Reference Grammar: predicate focus, sentence focus and narrow focus. Van Valin & LaPolla (1997) give examples from French.

4.2 Predicate focus:

Q: What happened to your car?

A: a. My car/It broke DOWN.
b. (Ma voiture) elle est en PANNE.

Sentence focus:

Q: What happened?

A: a. My CAR broke down.
b. J’ai ma VOITURE qui est en PANNE.

Narrow focus:

Q: I heard your motorcycle broke down.

- A: a. My CAR broke down
 b. C'est ma VOITURE qui est en panne. (1997:206-8)

Sentence focus is confusingly described in Van Valin & LaPolla 1997 as referring both to “the entire sentence” (1997:206) and to “the entire clause” (1997:207), a distinction which will be vital for the discussion of information structure in detached constructions. However, it is understood that the clause is the intended maximum scope of sentence-focus. This is deduced from the statement that “the potential focus domain [the syntactic domain in which the focus element(s) may occur] must fall within the scope of the illocutionary force operator” (Van Valin & LaPolla 1997:214). The illocutionary force operator, which determines whether the sentence is a question, a command, an assertion or an expression of a wish, operates at the clause level (Van Valin & LaPolla 1997:41). Therefore, the maximum scope of the potential focus domain in any sentence must be the clause, excluding detached elements.

Different languages have differing levels of flexibility in syntactic structure and also in focus structure and the interaction between these necessitates various strategies designed to meet the pragmatic needs of speakers; these strategies may involve intonation shifts or syntactic constructions. The consequent constraints in each language create varying potential focus domains for each sentence where the focus could be allowed to occur and, in each sentence, actual focus domains where the focus, in that instance, exists (Van Valin and LaPolla 1997:212). Focus domains for French are diagrammed as in Figure 8 (using an example sentence from the St Pierre French data):

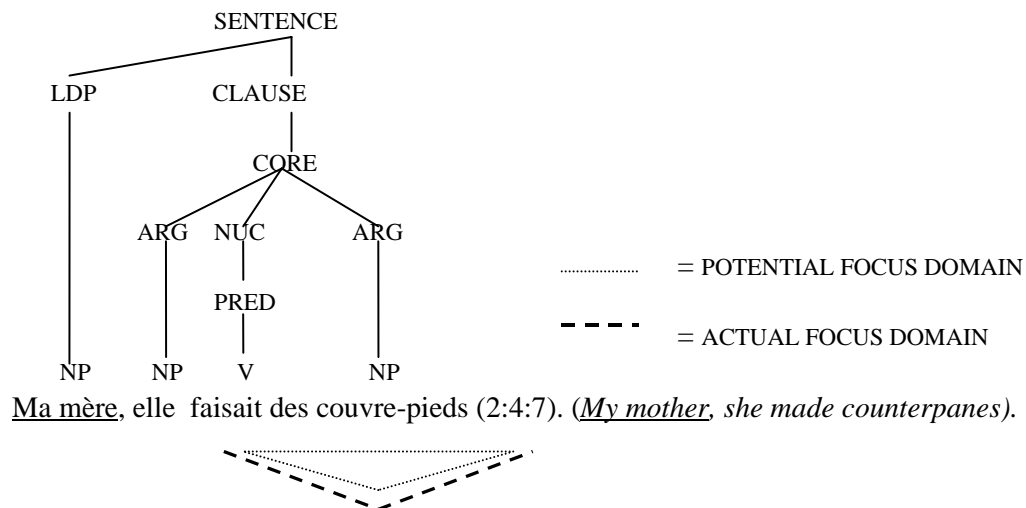

Figure 8: Formal Representation of Focus Structure (in Sentence 2:4:7)

French, the subject of the current study, is a language with a relatively restricted potential focus domain. Some aspects of French information structure interacting with syntax are the topic of the following section.

SECTION V

FRENCH

In French, as in several other languages, there is a rigid focus structure which puts a constraint against preverbal subjects being the focus of a sentence (Van Valin 1999:8) and also exhibits a consequent strong tendency towards clause-final focus (Lambrecht 1984:241). Unlike in English, where a shift in intonation can signal a shift in focus, syntactic means must be used in French to allow for different types of focus structure and to enable various elements in the sentence to be the focus. However, French also has a rigid syntax based around an SVO word order so extra constituents are added to the main clause to accommodate the pragmatic meaning. French uses various syntactic means to convey these differences in information structure, in order to avoid having focal elements in pre-verbal position. Two of these are cleft constructions; a third is the topic-comment left detachment (or comment-topic right detachment). This paper will later show that the use of the cleft constructions, particularly the so-called identificational **c'est** cleft, overlaps with the use of detachment constructions to create complex pragmatic and syntactic interactions.

5.1 Cleft Structures

5.1.1 Presentational **ya** Cleft.

The first of the cleft constructions is the so-called **ya** (**il y a**, 'there is'), or 'presentational' cleft. An alternate form is **j'ai** ('I have'). Examples of these from the St Pierre data are given below in 5.1 (with the relevant construction in bold):

- 5.1 a. Un peu comme quand **i'y a** des p'tits gamins q'marchent tout partout pis qui touchent tout t'sais (1:3:135).
*A bit like when **there are** little youngsters that walk on everything then touch everything, y'know.*
- b. Mais comme même i'a fallu qu'on sort tout qu'est-ce qu'on avait dans le sous-sol pis tout le monter en haut, mais **'y'en a** qui ça faisait vraiment pitié (2:3:44-6).
*But all the same it was necessary for us to take out everything we had in the basement then bring it all up high, but **there are some** that we were made to really pity.*
- c. i'ont resté pris sur, euh, au-dessous d'chaque pont.....ça bouchait le, le, la rivière complètement. Et pis **'y a** un qui a, **'y a** un qui a, qui a bouchait la rivière comme au 59 ici, (2:2:25-6).
*They stayed stuck on, uh, under every bridge.....that completely blocked the river. And then **there's (was)** one that, **there's** one that, that blocked the river like at (route) 59 here,*
- d. et pis **'y avait** M. Bourgeois qu'avait une voiture. (1:3:80-1).
*and then **there was** Mr Bourgeois who had a car.*

This construction is used when "the referent of the non-expressed canonical subject stands in a topic relation with the proposition but is new" (1984:245). In other words, as outlined above, this structure is used to express sentence focus. The 'non-expressed' subject is made the grammatical

object of the existential verb **avoir** ('to have', though **il y a** is usually translated with the English existential 'there is') and this phrase is followed by **qui** ('who/that') and the propositional clause. Lambrecht interprets this type of construction as a "syntactic amalgam, in which one and the same NP plays simultaneously the role of object and of subject" (Lambrecht 1984:246). In addition, the clause following the **qu'** is "necessarily asserted" (Lambrecht 1986:117). The syntactic structure of sentences containing this pragmatically functional cleft is "biclausal...used for the expression of a single piece of propositional information" (Lambrecht 1986:117). The following example in Figure 9 illustrates that in Role and Reference Grammar terms it is a two-core clause.

The sentence in Figure 9 below is a core juncture sentence – each core has its own nucleus and there is a core argument which is semantically an argument of the second nucleus as well as being a predicate of the first. It is a coordinate construction since there are no core operators which are obligatorily shared between the cores; in other words the modality and negation values for each core may differ. This follows since the **ya** cleft merely presents the referent of the NP in the discourse (Lambrecht 1986:118). The predicate of the first core is the NP – as in English, the non-verbal predicate requires "the copula *be* or some kind of copular verb to be used" (Van Valin & LaPolla 1997:25) which is not part of the syntactic structure, but an operator not diagrammed in the LSC.

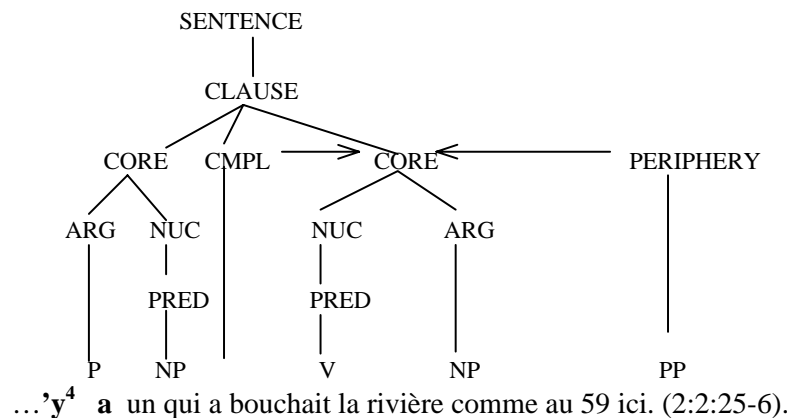

Figure 9: LSC for Sentence 4.3c

The verb **avoir** seems to be generally in the present tense even when this is different from the rest of the sentence, as in 5.1c. Elsewhere it is in the same tense, as in 5.1d. This is similar to the 'frozen' verb situation in the **c'est** cleft which will be discussed in the following section, and consequently suggests a similar interpretation.

5.1.2. Identificational **c'est** Cleft

The second kind of cleft used in French for pragmatic purposes is sometimes called the "identificational" cleft (Lambrecht 1984:248). The impersonal **c/ce** is coupled with the copula and the would-be subject is its object. This type of construction occurs if "the referent of the canonical subject would have a focus relation to the proposition and if the information conveyed by the proposition is itself not new but recoverable ('presupposed')" (Lambrecht 1984:248), that

⁴ **y** is interpreted for these purposes as a prepositional clitic containing argument information.

is, to create narrow focus on the would-be subject. 5.2 contains some examples of this construction from the data (again in bold):

- 5.2 a. Non, c'est, c'est, **c'est** qui a fait tout à manger, René, pour la fin de semaine? **C'est** Réal Curé qui a fait tout. (2:3:9).
*No, it's, it's, **it's** who (that) made all the food, René, for the weekend? **It's** Réal Curé who made everything.*
- b. Oui, j'ai passé toute ma vie ici; je me suis née ici, et puis je vie encore ici, dans la même maison que je suis née dedans. **C'était** mon mari qui est demenagé. (2:3:12-3).
*Yes, I've lived here my whole life; I was born here, and I still live here, in the same house that I was born in. **It was** my husband who moved.*
- c. ...la rivière a commencé à couler, la glâce a pas vraiment defaite. **C'était** des gros morceaux d'glâce qui sont, comme, qui ont commencé à couler sur la rivière. (2:2:23-4).
*...the river began to flow, the ice hadn't properly broken up. **It was (there were)** huge chunks of ice that were, like, that began to flow down the river.*
- d. Oui, mais **c'était** des élèves qui étaient, qui passaient plus de temps sur les murs que assis sur les chaises. (1:3:113).
*Yes, but, **it was (there were)** students who were, who spent more time on the walls than seated in their chairs.*
- e. On mets ça au goût. **C'est** une personne aime ça plus salé que d'autres. (1:2:24-5).
*We put this to the taste. **It's** one person likes it more salted than others.*
- f. Ben, c'est qu'les hôtels, dans ce temps là, ils avaient du bon sens, **c'est** seulement les hommes qui peu'y aller; alors i'étaient à l'abri. (1:3:186-7).
*Well, it's that the hotels, at that time, they had good sense, **it's** only men who could go there, so they were 'in the shade'.*

In the question within 5.2a, the relative **qui** (which might otherwise precede **a fait**) has been omitted by the speaker to avoid the awkward doubling with the **WH-qui** ('who'). (The question clause is addressed to a second listener).

Furthermore, the tense of the verb in the clefted constituent does not necessarily match the tense of the verb in the proposition, as in 5.2a and f, although it does in the other examples (see also in 5.1c for the presentational cleft construction). Also, the **ce/c'** does not necessarily agree in number with the object of the verb when it is used in this construction (see 5.2c, d). In 5.2e, no verb of any kind is called for in translation into English – the **c'est** seems to carry no semantic meaning, rather it is carrying out a pragmatic focus-marking function.

These observations match those of Lambrecht who notes that the verb form in these constructions is “more or less frozen” (1984:249) as third person singular present **est**. The St Pierre data suggests the tense is not quite completely frozen; the question of the number of the verb is difficult to answer where the verb is in the past imperfect as third person singular and

plural are then homophonous, but it seems likely that it is singular since this is the trend for the verb in the present tense, and it then agrees with the *c/ce*.

Lambrech further states that the head noun in a *c'est* cleft cannot be referentially non-specific (1984:249). However, as with the *ya* cleft, there seems to be an exception: 5.2e would seem to violate this since its referent ('a person') is non-specific. A loose translation of the sentence might be 'some people like it more salty than others'. 5.2f might also violate the constraint against non-specific referents in the *c'est* cleft. The referent of *quelquechose* is a topic that R is proposing be talked about.; however, at the point of the utterance, while it may be specific to him, he has not said what it is. This broader use of the *c'est* cleft could then be another feature particular to this Canadian French language variety.

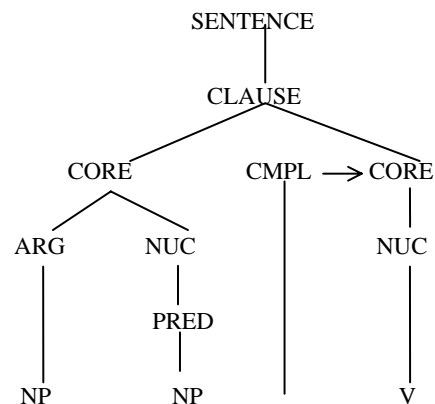

C' était mon mari qui est demenagé.

Figure 10: LSC for Sentence 4.4b

The structure of the *c'est* cleft clause bears a syntactic resemblance to the *ya* cleft in that it is also a coordinate core juncture structure, the predicate NP in the first core also being an argument of the predicate in the second core.

5.2 Left Detachment Structures

The third type of construction used in French to overcome rigid syntax and rigid focus structure and typically invoked to achieve predicate focus is detachment constructions. While the description of the presentational *ya* cleft and the identificational *c'est* cleft served as essential background, detachment constructions are the main focus of this paper. This section will focus largely on various characteristics of different types of left detachments; as can be seen above, these are much more common in the St Pierre data than right detachment constructions and much of the existing literature also focuses on left detachments. Right detachment constructions will be discussed later in section 5.3.

In left detached (LD) constructions, an element appears to the left of the main clause. This element may or may not corefer with an anaphorical element in the main clause. The example below, repeated from 1.1b, illustrates the LSC for this type of structure.

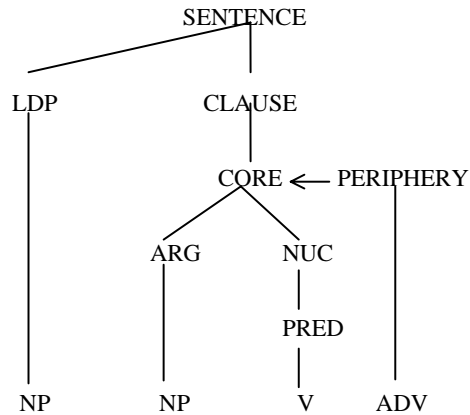

Le printemps, il était venu tard. (1:3:196). (*The spring, it came late.*)

Figure 11: LSC for Sentence 1.1b

5.2.1 Use of *ce* as Anaphor.

The first aspect of left detachment to be discussed proceeds directly from the previous section concerning the identificational *c'est* cleft. The use of *c'est* ('it is') and the *c'est* cleft described above is significant in reference to a feature of LD observed in the St Pierre data. There are several cases where the impersonal third person pronoun *ce* is used as an anaphor in the main clause to corefer with a detached phrase where the personal third person pronouns *il/elle* might be expected. In French, the third person pronominal forms *il* (masculine) and *elle* (feminine) are used not only when the referent is male or female (respectively), but also generally used with masculine or feminine gender nouns (and where English 'it' would be used); for example,

- 5.3 Il est bon mais il n'est pas tout à fait assez bon. (1:2:29).
It [the butter] is good but it's not quite good enough.

Several of the speakers in the St Pierre data use *ce* rather than *il/elle* to corefer with detached lexical NPs *not* denoting people, but one speaker, an older man, repeatedly uses the impersonal *ce* in preference to *il/elle*, even when referring to his own mother (5.4b):

- 5.4 a. Guy, c'est le meilleur goûteur à beurre. (1:2:24).
Guy, he is the best butter taster.
- b. Ma mère, c'est...Mme Ovila Desharnais. (1:2:67).
My mother, she's...Mrs Ovila Desharnais.
- c. Alors des anglais, c'est des ennemis! (1:2:83-4).
So the English, they're the enemies!
- d. ...des français, des francophones, c'est têtus, ça un peu. (1:2:99).
...the French, French-speakers, they're stubborn, just a bit.

5.5 (below) gives examples from the data of the use of personal third person pronominal forms *il/elle*. As with the impersonal *ce*, the personal pronominal forms are used both with referents denoting people (e.g. 5.5c) and referents not denoting people (5.5a, b). It would appear, therefore, that the human/non-human distinction is not helpful in understanding the use of *ce* versus *il/elle*.

- 5.5 a. et pis, euh, après cela les mentries, j’pense, ils sortaient enfin; que’q’ chose d’même. (1:3:146).
and then, uh, after that the lies, I think, they come out eventually; something like that.
- b. Le printemps, il était venu tard. (1:3:196).
The spring, it came late.
- c. Ces gens cela, il’ ont assuré la survie du français au Manitoba (1:2:108-9).
These people, they assured the survival of French in Manitoba.

Lambrecht (1981) also shows that the development of the use of coreferring **ça/ce** over the personal **il/elle** is not a straightforward issue of human vs. non-human reference. He argues that a generic/specific distinction, while not accounting for all examples, is relevant. The example he uses to illustrate this is repeated in 5.6:

- 5.6 a. Les légumes c-est où?
 b. Les légumes i-sont où?
Where are the vegetables? (Lambrecht 1981:43).

While both these sentences mean the same thing, Lambrecht argues that they carry different pragmatic connotations illustrative of a systematic contrast. From his own intuitions, he interprets 5.6a with a more generic reference; it would be used in a supermarket to locate the vegetable section. 5.6b, on the other hand, would be used by someone who gets home from the supermarket and is trying to locate the vegetables s/he bought (Lambrecht 1981:43). However, this account does not seem to fit the St Pierre data in 5.4: the detached NPs in 5.4a and b have a specific referent, where no generic reading is possible, and where a personal pronoun might be expected. This suggests there could be another factor involved in the choice of **ce** over **il/elle**.

This other factor, which could be more significant than both the human/non-human and the specific/generic distinction, is the use of **être**. In the sentences in 5.4, the **ce** always occurs with the copula verb. In the sentences in 5.5, on the other hand, **il/elle** occurs with other verbs.

This patterning of **ce** with **être** and **il/elle** with other verbs is also found by Barnes (1985). To account for this, Barnes suggests that “the use of left detachment is quasi-obligatory with lexical subjects of être whenever ce/c’ is an appropriate anaphor” and that the form **NP c’est** is thus becoming grammaticalized (Barnes 1985:49). Her findings cause her to dispute Lambrecht’s observation that in spoken French, non-detached lexical subject NPs “occur in their vast majority in *intransitive* clauses, in particular in clauses containing the verb *être* ‘to be’” (1984:26). However, the St Pierre data would seem to support at least the latter part of Lambrecht’s observation:

- 5.7 a. H: Pis...on fait de meilleur argent là quand ils ont des bulles d’air au tour là.
 G: La bulle d’air est grosse. (1:2:54-55).

*H: Then...we make better money when they have air bubbles around there.
 G: The air bubble is big/rich [pun].*

- b. Et pis M. Bourgeois, il (nou)s a conduit, et M. Bourgeois est taquineur. (1:3:87-8).
And then Mr Bourgeois, he drove us, and Mr Bourgeois is a tease.
- c. Pour faire le sirop, euh, on le...le sirop bouillit à 105°, le point d'ébullition est 105°. (2:2:2-3).
To make syrup, uh, we...the syrup boils at 105°, the boiling point is 105°.
- d. La tarte au sucre est pas fait ici uh? C'est fait à St Pierre mais c'est fait à la boulangerie// (2:3:2).
The sugar tart is not made here, eh? It's made in St Pierre but it's made at the baker's.

In fact, judging from comparison with the sentences in 5.4, **ce/c'** would seem to be an appropriate anaphor for the detached lexical NPs in the sentences in 5.5 (compare 5.7b and 5.4a) and yet these sentences are not detached. This suggests that there may be yet another factor influencing the choice between a left detached construction (with coreferring **ce**) and a sentence with SVO word order.

It is significant to note, in discussing this question, that in 5.4, all the sentences carry focus on the predicative NP/AP following the **c'est** and that this focused element expresses an attribute of the referent of the detached constituent. This coincides with the general use of LD as creating predicate focus, the difference being that sentences where the predicate is not the verb appear to contain an anaphorical **ce** and sentences where the predicate is a verb tend to take **il/elle** as the coreferring element. This contrast is clear when comparing 5.4b (repeated below) to a very similar sentence with the same referent (relative to the speaker) but containing a different verb. In this case (5.4e), the personal pronoun is used:

- 5.4 b. Ma mère, c'est..Mme Ovila Desharnais. (1:2:67).
My mother, she's..Mrs Ovila Desharnais.
- e. Ma mère, elle faisait des couvre-pieds (2:4:7).
My mother, she made counterpanes.

If this is the case, then what needs to be accounted for is why a speaker would choose a detached sentence such as 5.4b over a 'basic' SVO sentence (5.4b') where the postverbal predicative element already receives focus:

- 5.4 b'. Ma mère est Mme Desharnais.
My mother is Mrs Desharnais.

One reason why a sentence such 5.4b' would be unlikely to occur is given by Lambrecht (1984). Lambrecht argues that the SVO sentence type with full lexical NPs is not the basic pattern in French. He examines several corpuses of data where he finds that "the number of canonical SVO sentences containing both a lexical subject NP and an object NP approximates zero" (Lambrecht 1984:239). In his more recent study of spoken French, Ashby (1999) confirms that "la phrase avec un verbe transitif et deux arguments de forme lexicale,...est peu fréquente dans la langue parlée" (Ashby 1999:481). The sentences in 5.7 show that SVO sentences with lexical arguments do sometimes occur. It is significant that in those examples the subject NPs are highly

topical, having been mentioned in the sentence before, thus perhaps lessening the need for the topicalizing LD construction.

In addition to this, it will be remembered that **c'est** is part of the so-called **c'est** cleft which is the syntactic means French uses to achieve pragmatic narrow focus on a constituent (as outlined above in section 5.1.2). In sentences with non-verb predicates (such as in 5.4) the distinction between predicate and narrow focus is lost – there is narrow focus on the predicative NP/AP. This is illustrated in Figure 12 below:

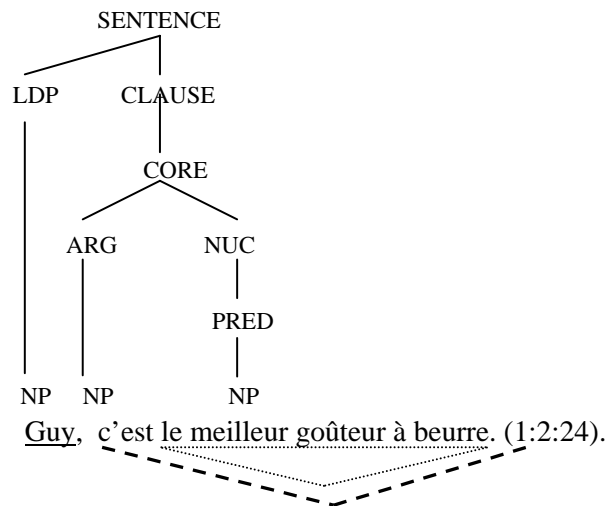

Figure 12: Focus Domain for Sentence 4.5a

This narrow focus could therefore be another reason for the predominance of **ce** as the anaphorical element in such sentences containing a detached lexical NP, **être** as the verb, and a predicative NP/AP. It would appear that the use of **c'est** in these LD constructions helps create an almost superimposed narrow focus on the element that follows it (as in the **c'est** cleft). Barnes calls **c'est** “a sort of ‘all-purpose’ pragmatic connector” (1985:56) and certainly pragmatic connector would seem to suitably describe the use of **c'est** in this type of construction the data.

This explanation might also explain why agreement in person (on **ce**) and in tense (on **est**) between the **c'est** and the surrounding sentential context is, at most, optional. The role of **c'est** seems to be at least partly that of the **c'est** cleft, as a pragmatic connector conferring narrow focus on the following element. This pragmatic role of **c'est** as a unit may be superimposed on the syntactic role of **ce** as an anaphorical element, coreferring with the detached constituent. As was seen in section 5.1.2, the **c'est** can carry little semantic meaning, but has a clear pragmatic function.

To look at the issue from a slightly different angle, this interpretation suggests that it is not so much that **ce** is expanding the kind of referents it can corefer to (whether in terms of human/non-human or specific/general), but instead possible that sentences such as those in 4.5 actually have no anaphor and the **c'est** is a focus-marking element. This correlates with Lambrecht who argues that “from a strictly grammatical point of view, all TOP [LD] phrases are unlinked” (Lambrecht 2001:24).

This would suggest the possible interpretation that left detached lexical NPs with **être** in the main clause do not have coreferring pronominal elements in quite the same sense as other LD structures. Instead, **c'** is inserted to help create narrow focus on the non-verb predicate in the main clause. This is reflected in the way such sentences pattern with sentences which clearly have no syntactic anaphor, and where the narrow focus marking behavior of **c'est** is evident. The data contains examples of such sentences:

- 5.8 a. On était mieux, eux-autres, eux-autres, c'était pire. (1:3:56).
We were better-off, those-others, those-others, it was worse.
- b. //Parce que 'y avait des maisons dans...dans la plus belle partie de St Jean, juste sur le côté d'la rivière, c'était une inondation toute les deux ans garantie. (1:3:127-8).
Because there were houses in...in the prettiest part of St Jean, just on the banks of the river, it was one flood every two years guaranteed.

In the literature on detached constructions, sentences such as those in 5.8 are generally separated from those with 'visible' anaphoric elements, and attempts then are made to account for the occurrences of impersonal **ce** and personal **il/elle** pronominal forms. In fact, there seems to be more cause to group together sentences where the pronominal element is **ce**, and to see that, whether this element appears to corefer with the detached constituent or not, its role in helping determine the focus structure of the sentence is the same. (More will be said about left detached sentences with no anaphor in the following section.)

One sentence from the St Pierre data is particularly interesting in the light of the discussion above:

- 5.9 depuis 10 ans je demeure à Winnipeg mais quand j'ai parti j'ai pas tout emmené, mais **c'est mon cœur**, i'est ici. (1:3:73-4).
*10 years ago I moved (move?) to Winnipeg but when I left I didn't take everything, but **it's my heart**, it's here.*

In this example, **mon cœur** receives narrow focus within the detached constituent by the use of **c'est** and it is simultaneously topicalized by being left detached.

The coreferring pronoun is the personal pronominal element **il**, not **ce**. It may be that **être** may occur with the personal pronouns when followed by a locative prepositional phrase. It may also be that the use of **i(I)** in the main clause helps highlight the focusing function of **c'est**, placing **mon cœur** in greater focus than **ici**.

In section 4.2 above, the sentence repeated below in 5.10 is given by Van Valin and LaPolla (1997) as an example of a detached sentence that creates predicate focus (*i.e.* it could be a response to the question, 'What happened to your car?'):

- 5.10 (Ma voiture) elle est en PANNE.
(My car) it broke down. (1997:206).

Following the discussion above, the somewhat artificial feel of this sentence (if the NP in parentheses is included) can be explained. The verb in the main clause is **être** which, as I have shown, is disinclined to occur with a detached lexical NP, a non-verb predicate in the main

clause, and anaphoric personal pronominal forms. A more likely utterance would be the following:

5.10' (Ma voiture), c'est en panne.

Here the predicative AP in narrow focus is preceded by **c'est**, following the pattern described above.

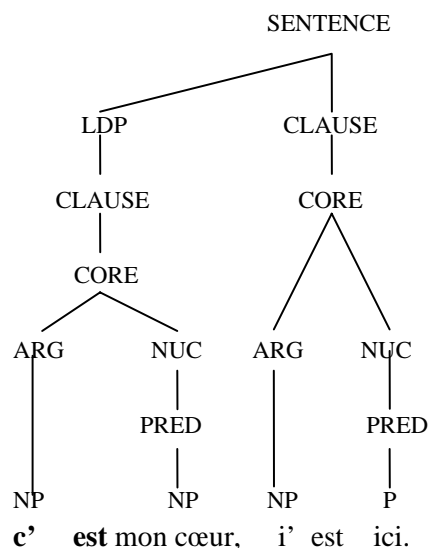

Figure 13: LSC for Sentence 5.9e

In another study of the use of impersonal and personal third person anaphorical elements in left detached sentences, Barnes (1985) suggests that the information status of the referent of the detached element could play a part. Her findings are reproduced below in Table 3 (indicated by B) to the right of the statistics for the St Pierre data.

Table 3: Information Statuses of Lexical LD Referents with Subject Anaphors (Barnes data: Barnes 1985:63)

	Evoked		New		Total	
NP ce/ça...	8 (80%)	B 143 (78%)	2 (20%)	B 41 (22%)	10 (31%)	B 184 (69%)
NP il(s)/elle(s)...	11 (50%)	B 34 (39%)	11 (50%)	B 48 (61%)	22 (69%)	B 82 (31%)
Total	19 (59%)	B 177 (66%)	13 (41%)	B 89 (34%)	32	B 266

Barnes's terms, taken from Prince (1981) but altered for her purposes, are used in the table below for easier comparison. 'Evoked' is meant to include "referents previously mentioned [in the same discourse segment] in the discourse and referents which are part of the situational context" (Barnes 1985:62). In Role and Reference Grammar terms, referring back to Figure 6,

this refers to identifiable referents which may be either active, or textually or situationally accessible.

By ‘New’ is meant “new to the discourse but identifiable by the listener [New-Unused or Inferable]...not evoked” (1985:62). In Role and Reference Grammar terms, ‘new’ would thus refer to identifiable referents which are inferentially accessible or inactive. LDs are not used with unidentifiable (or ‘Brand-New’) referents; there is always a “high degree of [semantic or referential] cohesion” (Barnes 1985:80) between the LD referent and the discursive context that follows an LD – this is a general pragmatic constraint on the use of LDs.

While Barnes’s corpus of data is much larger there are striking similarities and also dissimilarities between the two sets of statistics. The percentages of evoked and new referents that are used with **ce/ça** and with **il(s)/elle(s)** are quite similar between the two sets of data, especially for the impersonal pronoun, suggesting the selection processes to be similar for the St Pierre speakers. The fact that 41% of the lexical NP LDs in the St Pierre data involve ‘new’ referents supports, even more than her own data, Barnes’s conclusion that “LDs with referents which are new to the discourse...are by no means a marginal phenomenon” (1985:75). The predominance (St-P 59%, B 66%) of ‘evoked’ referents, on the other hand, would be expected, given the topic hierarchy mentioned in section 4.2: ‘evoked’ (active/textually or situationally accessible) referents would be less marked for selection as topics than ‘new’ referents.

Regarding the percentages of ‘evoked’ and ‘new’ referents used with a coreferring **ce/ça**, it can be seen that ‘evoked’ referents are more common (80%, as against 20% with ‘new’ referents for the St Pierre data). This observation interacts with the discussion above: it is possible that when the referent of the detached constituent is ‘evoked’ there is less need of a *personal* pronominal anaphoric form (**il/elle**) to assist the hearer in identifying the referent. In other words, the data suggest that the use of **ce** as the anaphoric pronominal in a left detached sentence with a lexical NP and, significantly, the pragmatic use of **ce** as part of the **c’est** construction denoting narrow focus, is more likely to be acceptable when the referent is already ‘evoked’ and easier for the listener to access.

Looked at more closely, all but two of the ‘new’ referents in the St Pierre data could be interpreted as ‘inferable’ rather than ‘inactive’, the exceptions being one case with a proper noun (referring to someone not present) and another with the referent **tout l’monde** (‘everyone’). The majority of the inferable referents (eight out of eleven) are inferred from the presence of a first person possessive pronoun before the noun, to which the referent of the noun can be connected. An ‘inactive’ referent is “in the hearer’s long-term memory, yet not in his short-term memory (*i.e.* not in either the focus or periphery of consciousness)” (Van Valin & LaPolla 1997:200). If this is taken to refer to the same type of referent as ‘New-Unused’ (new to the discourse but identifiable to the hearer) then this majority of inferable referents differs somewhat from Barnes’s corpus where “LD-referents of the New-Unused [inactive] type are not uncommon” (1985:62).

Those NP LDs where the referent is not accessible by means of an inferred relationship with the referent of the possessive pronoun could be classed as ‘inactive’ – their referents have not been placed “in the focus or periphery of consciousness” (Van Valin & LaPolla 1997:200) by the preceding discourse. However, their referents are still accessible, rather than unidentifiable, due to a type of linking. For example:

- 5.11 a. [19-20 (discourse topic)] à quatre-vingt dix-sept, durant l'inondation du centenaire là, au Manitoba, on avait, c'était durant notr' cabane à sucre quand que ça a frappé à St Pierre,.....[23] et pis la rivière, elle a, euh, ben, la neige a fondu de très très vite, (2:2:19, 23).

[19-20] In 1997, during the flood of the century, in Manitoba, we had, it was during our 'cabane à sucre' when that hit St Pierre,.....[23] and then the river, it, uh, well, the snow melted very very fast,

- b. Mes histoires, ils commençaient après le, le...deux tières [de la bouteille] et pis, euh, après cela les mentries, j'pense, ils sortaient enfin; que'q'chose d'même. (1:3:145-6).

My stories, they start after the, the...two thirds [of a bottle] and then, uh, after that the lies, I think, they come out eventually; something like that.

In 5.11a the linking is of the “referential linking” type proposed by Reinhart where the “referent in the second sentence belongs to the ‘frame of reference’ established in the first” (Reinhart 1982:19). Barnes (1985:69) usefully extends this linking to refer to relatedness to the preceding discourse, rather than the immediately preceding sentence, as does Larsson; “le thème indiqué par le membre disloqué à gauche fait partie d’un répertoire de thèmes qui ont une certaine actualité dans la situation de la parole” (Larsson 1979:12). This accounts for 5.11a, where the relevance of the referent of **la rivière** is dependent on the established discourse topic of the flood and also somewhat dependent on a knowledge of the geographical situation of St Pierre and its river.

5.11b is an example of a more semantic type of linking between the underlined LD clause and the preceding clause, again as proposed by Reinhart and expanded by Barnes (1985). The NP **les mentries** (‘the lies’) is new and unpredictable, but there seem to be semantic and possibly also syntactic clues to assist the listener in accessing the referent of the second LD NP. The repeat of the LD structure helps the listener connect the second NP with the first (**mes histoires** (‘my stories’)) and the two clauses are also “linked by an overt, or easily recoverable semantic connector” (Reinhart 1982:20), in this case **après cela** (‘after that’) and possibly also **enfin** (‘eventually’).

Looking back at Table 3, the totals in the two sets of data are very different. Roughly two thirds of Barnes’s LD lexical NP constructions have an impersonal **ce/ça** anaphor and only about a third have personal pronominal anaphors. This is the opposite of the case for the St Pierre data where 69% of the detached lexical NPs have **il(s)/elle(s)** as anaphorical pronominal elements in the following clause. Clearly, the impersonal **ce/ça** is not as all-pervasive in the St Pierre corpus as it is in Barnes’s data. This is significant because Barnes takes the overwhelming frequency of **ce/ça** in her corpus of data to be another strong sign that the form **NP c’est** is becoming grammaticalized. The St Pierre data does not provide such a strong defense for this assertion, at least in terms of that language variety.

5.2.1.1 Ça c’est Construction

The copula verb **être** is also involved in another LD construction common in the data, **ça c’est** (‘that it is’). Barnes observes that “ça c-... represents a deictic subject pronoun, while c-... represents a merely anaphoric subject (before *est/était*)” and notes that this deictic use carries a

hint of the same contrastive/emphatic sense as other LD constructions (1985:44). The deictic nature of **ça c'est** and its reference to something “evoked”, that is, “which is salient in either the situational or the preceding linguistic context” (Barnes 1985:63, 46) is clearly illustrated by the St Pierre data in 5.12a and b.

- 5.12 a. **ça c'est** une grand photo prise en 1916. (1:2:96).
That (it)'s a big photo taken in 1916.
- b. Mais pas cette eau – **ça c'est** jeté. (1:2:11).
But not this water – that (it)'s thrown away.
- c. On vit...on était élevé avec un certain honte de c'qu'on est, t'sais – on est moins parce qu'on, i' faut se cacher pour être. C'est, c'est profond, **ça**. (1:2:107-8).
We live...we were raised with a kind of shame about what we were, you know – we are lesser because we, we must hide to exist. It's, it's deep, that.
- d. G: C'est parce qu'il est bien lavé, t'vois? Si i'avait pas été lavé, **ça c'est**//
 H: //c'est **ça**, **la** gros différence. (1:2:39-40).
 G: It's because it's well washed, you see? If it hadn't been washed, that it's//
 H: It's that, the main difference.

The RD equivalent constructions **c'est...**, **ça** and **c'est ça [RD]** illustrated in 5.12c and d do not have the same deictic implications, just as RD constructions do not have the same comparative/contrastive connotations (see section 5.3). The RD constructions in 5.12 pick out an already established aspect of the topic under discussion for continued focus – the referent need not be situationally salient though will most likely be linguistically available, since this is the pragmatic condition for the use of an RD construction. 5.12d shows both **ça c'est** (after which the speaker was interrupted) and **c'est ça**. There is only one example in the St Pierre data of an RD construction containing RD **ça** referring to a situationally evoked referent (and it does not involve **c'est** in the main clause), while there are seven such examples for LD constructions (including 5.12a and b).

This deictic use of LD **ça c'est** contrasts somewhat with a general observation in the literature that, with lexical NPs, RD rather than LD is usually used in deictic contexts, for referents that are situationally accessible or salient: “objects in the immediate nonlinguistic context are more often introduced into the discourse by means of a right detachment construction than by a lefthand one.” (Barnes 1985:64; Lambrecht 2001:27). In the St Pierre data the ratio between LD and RD used with this type of referent is 50:50 but there is only one example of each.

5.2.1.2 NP c'est que Construction

Another type of LD construction involving the copula is the left detachment type **NP, c'est que** (‘NP, it's that’). Barnes (1988) shows that **NP, c'est que [clause]** is a particular kind of left detachment in French whose discursive function is to “enhance the coherence of the discourse...[as it] serves as a link between the preceding and the following discourse...and...indicates...what [the] connection [of the proposition(s) to follow] is to the preceding discourse” (Barnes 1988:37). Barnes argues that the use of these constructions gives the following proposition “greater communicative value” by adding to the coherence in this way and notes that they differ from LD proper in their inability to be mirrored by equivalent RD syntactic

constructions (1988:41). In her corpus of 10 hours, Barnes found 39 utterances of this type: only 7 involved a detached **ce qu-** relative, while the rest contain an LD lexical NP or other expression.

In the St Pierre data there is one example of the first type (5.13a) and one of the second type (5.13b). Figure 14 shows an example LSC for this type of structure, in this case for 5.13b.

- 5.13 a. essentiellement, ce qu'ils disaient, c'est q'les mères étaient tellement stressées pendant l'inondation qu'les enfants qui sont nés à cette période-là, i'étaient.....énormement agités...(1:3;107-8).

And they described how, basically, what they said, it's that the mothers were so stressed during the flood that the children that were born during that time, they were.....greatly disturbed.

- b. Mais j'pense qu'l'problème, c'est qu'les gens savent parler, i'savent pas écouter. (1:3:45).

But I think that the problem, it's that people know how to talk, they don't know how to listen.

Sentence 5.13b' below shows 5.13b as a non-detached construction.

- 5.13 b.' Mais j'pense qu'l'problème est qu'les gens savent parler, i'savent pas écouter.

But I think that the problem is that people know how to talk, they don't know how to listen.

Comparison between 5.13b and 5.13b' reflects Barnes's observations — while **l'problème** is not a discourse topic, unlike most LD elements, the use of the detached construction highlights the connection between the preceding discourse and the (focused) proposition to follow; in this case, summarizing the problem in different terms and emphasizing that it is indeed a problem. In a sense, while not offering a new discourse topic, this pragmatic/discursive role bears a resemblance to that of most LD constructions in offering a comparative, new angle on the topic at hand. As with the cleft constructions, the tense of the copula seems to be in the present even where the main verb is not. And, as with the **c'est** cleft construction, the predicative clause **qu'les gens savent parler** is placed in focus.

There could also be another constraint working against the likelihood of 5.13b' occurring in spoken French, namely the tendency to avoid transitive sentences with two lexical NPs which was outlined above.

As Barnes points out (1988:35), the similar undetached construction **c'est que S** can be used autonomously – these examples from the St Pierre data in 5.14 suggest an implied, detached **la situation** ('the situation') or similar:

- 5.14 a. ...quand tu travailles t'a beaucoup moins de temps libre, c'est que, j'ai commencé en faire et pis le première an je n'en pour n'en faire un, (2:4:2-3).
...when you work you don't have much free time, it's that, I began to do it and then the first year I only made one,

- b. Ben, c'est qu'les hôtels, dans ce temps là, ils avaient du bon sens, (1:3:186).
Well, it's that hotels, at that time, they had good sense.

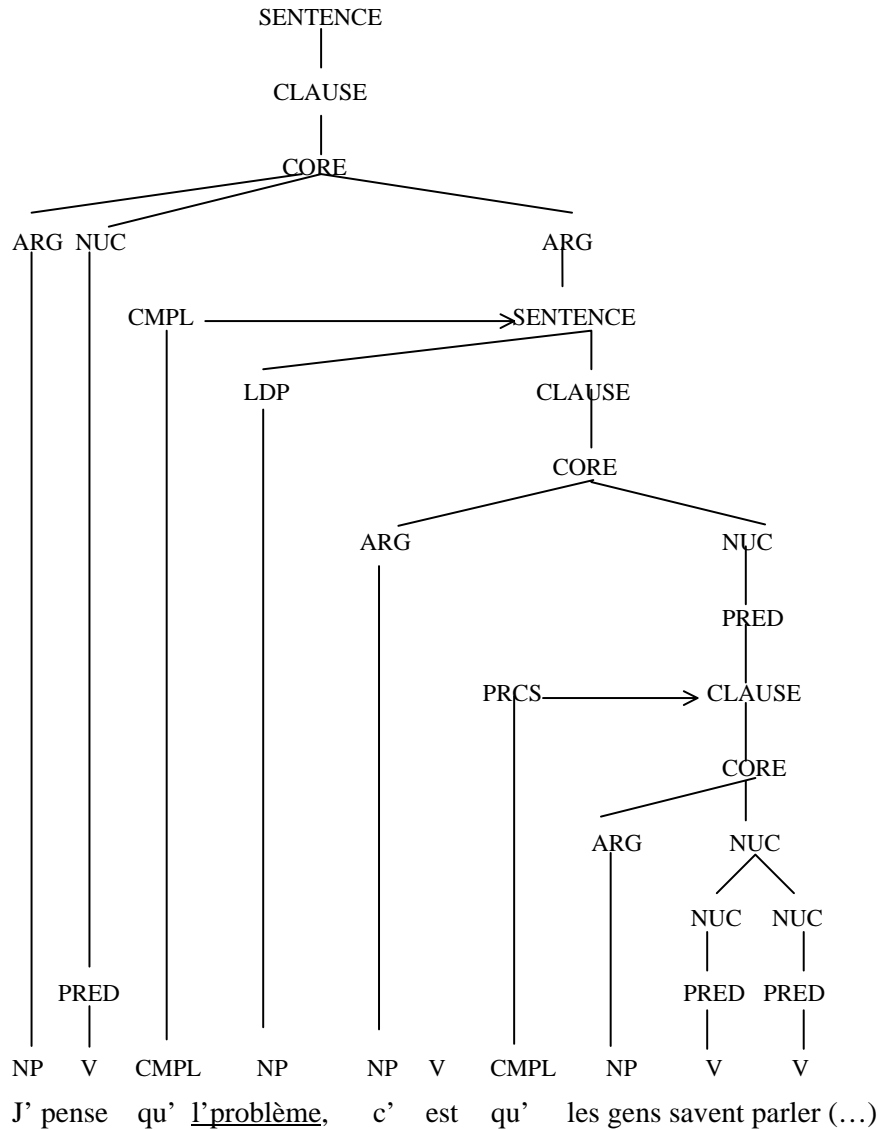

Figure 14: LSC for Sentence 5.13b

The phrase **ça fait que** is also quite frequently used, particularly by younger people, in St Pierre. It usually appears in a somewhat condensed form and, as the examples in 5.15 illustrate, carries a meaning along the lines of ‘what this means is/what I mean is’ (5.15a) but is often just used as an expression meaning something like ‘so there it is’ (5.15b).

- 5.15 a. *Moi, j’aime ça, vivre à St Pierre, p’ce que...uh c’est pas, euh, si gros, ça fait qu’tu, tu peux faire plus de choses... (1:1:16).*

Me, I like that, to live in St Pierre because...uh, it’s not, uh, so big, what I mean is that you, you can do many things...

- b. *‘Ya un forum de legos en bas, pis Loïc aime les legos – ça fait qu’là. (1:1:54).
There’s a forum(?) of lego down there, and Loïc likes lego – so there it is.*

This form seems, in this variety of French, to approach the function of a “marker of conversational structure” (Barnes 1988:42) along the lines of **ben** (‘well’) and **voilà** (‘there it is’) and the highly frequent **pis** (‘(and) then’). These markers “ensur[e] the ongoing smooth development of the discourse” (Barnes 1988:42-3).

5.2.2 ‘No Anaphor’ LD Structures

Another type of LD construction occurs with no clear anaphor in the following clause. There are at least 12 examples of such sentences in the St Pierre data. This is 15% of the total LD constructions found, a percentage which is a little higher than the 10% found by Barnes (1985) which she already notes as “a bit higher than one would expect, given Larsson’s (1979) description of such cases as ‘exceptional’” (1985:15). Also, 75% of these are with detached pronouns, again a little higher than Barnes’s 57% (1985:98). However, some of the cases in the St Pierre data do have anaphors in the form of possessives (5.16a) and/or anaphors in a subsequent clause, rather than in the clause immediately following the detached element (5.16b,c); these anaphoric elements are indicated by double underlining.

- 5.16 a. Des anglais...elle connaît pas le...nous-autres, i’ fallu se battre pour sauver notre langue au Canada, (1:2:81).
The English...she doesn’t know...us-others, it was necessary to fight to save our language in Canada,
- b. Moi, ça dépend avec qu’est-ce que je veux faire, ça. (1:1:65).
Me, that depends on what it is I want to do, that.
- c. Moi, ça, c’est à deux semaines avant, avant la dâte et mon père, il disait à ma mère, “on va aller tout d’suite à l’hôpital...” (1:3:86-7).
Me, that, it’s two weeks before, before the date and my father, he said to my mother, “we’re going to go to the hospital immediately...”

If such cases as these are excluded, that leaves eight cases with no anaphor (10% of the total left detachments), 50% of which contain LD pronouns. These cases include the following (5.17a contains two examples).

- 5.17 a. Quoi qu’à St Jean, Grand Fourches, les gens étaient pas habitués des inondations tellement, celle de ’97, c’était effrayant pour les autres. St Jean Baptiste, c’est une mode de vie//. (1:3:123-5).
However (it was) at St Jean, Grand Forks, people weren’t accustomed to such floods; the one in ’97, it was frightening for the others. St Jean-Baptiste, it’s a way of life//.
- b. R: Mes histoires, ils commencent après le, le...deux tières...
 F: Moi, ça ne va pas mal plus long mais... (1:3:146-7).
*R: My stories, they begin after the, the...two thirds...
 F: Me, it doesn’t take that long but...*

As is noted by Barnes (1985) in her discussion of LDs with no anaphor in the main clause, some of the left detached elements do not seem to correspond to the sentence topic according to the definition given by Reinhart (1982): “an expression will be understood as representing the topic if the assertion is understood as intending to expand our knowledge of this topic” (Reinhart

1982:6). Barnes points out that this non-sentence-topical characteristic can also be a feature of detached sentences which do have anaphor; there are several potential candidates from the St Pierre data, both LD and RD, to illustrate this. 5.18a and b are examples of the somewhat ‘distant’ anaphor described above; in the case of 5.18b there is a tenuous semantic link between moi and la d ate, meaning ‘the date of my birth’, the speaker’s birth being the sentence topic.

- 5.18 a. Des anglais...elle conna t pas le...nous-autres, i’ fallu se battre pour sauver notre langue au Canada,... (1:2:81).
The English...she doesn’t know...us-others, it was necessary to fight to save our language in Canada,...
- b. Moi,  a, c’est   deux semaines avant, avant la d ate et mon p re, il disait   ma m re, “on va aller tout d’suite   l’h pital...” (1:3:86-7).
Me, that, it’s two weeks before, before the date and my father, he said to my mother, “we’re going to go to the hospital immediately...”
- c. Moi, j’ tais l    l’ cole et toi [N] aussi, tu connais  a. (1:2:104). (‘ a’ = the need to hide French books when the English-speaking school inspector came).
Me, I was there at school and you [N] too, you know about that.
- d. La flood en ’50, t’en rappelles, toi? T’ tais jeune. (1:3:192).
The flood in ’50, do you remember it, you? You were young.

In 5.18d, the left detached NP takes precedence as sentence topic over the RD pronoun. The right detached phrase in the sentence is an invitation to the addressee to participate in discussing his experience of the flood in 1950 (which the others in the conversation are too young to remember); the (left detached) ‘flood in 1950’ is the sentence topic. Barnes (1985) suggests that these types of LD sentences correspond to Chafe’s definition of “Chinese-style topics” (1976:50), following the type of topic-comment structure found in Mandarin. This type of topic “sets a spatial, temporal, or individual framework within which the main predication holds” (Chafe 1976:50).

However, the main clauses in the examples in 5.17, while not containing anaphorical elements, in each case do in fact seem to intend to expand the hearer’s knowledge about the left detached element. There seems to be an additional link between the pragmatic role of the sentence topic in these sentences and the role of the detached element in its work in relation to the predicate. In all the cases in 5.18, detached pronouns, while not determining the sentence topic as such, seek to narrow the sentence topic to its relation to the referent(s) of the pronoun, as described above for 5.18d. They work in combination to “limit the applicability of the main predication to a certain restricted domain” (Chafe 1976:50).

Thus, the situation here is similar to the account of the use of the impersonal pronominal ce described above, where pragmatics was seen to supersede issues of anaphorical agreement. The distinction between detached sentences with visible anaphor and those without, in this case by Barnes (1985), seems to cut across her own generalization, which has been extended here, regarding the pragmatic relation between the detached element and the main clause.

5.2.2.1 Subtypes of LD Sentences with No Anaphor

While such general observations of pragmatic behavior can be made that apply to detached sentences both with and without anaphor, it is also useful to examine the properties of detached sentences with no anaphor as a group. Using her corpus of data, Barnes (1985) divides ‘no-anaphor’ LDs into two groups, both of which can be illustrated by the St Pierre data. In the first type, the detached element, usually an NP, “is interpreted adverbially, giving the appearance of a PP from which the preposition has been deleted” (1985:100-1). Here is a case of such a no-anaphor LD construction from the St Pierre data:

- 5.19 Quoi qu’à St Jean, Grand Fourches, les gens étaient pas habitués des inondations tellement, celle de ’97, c’était effrayant pour les autres. St Jean Baptiste, c’est une mode de vie//. (1:3:123-5).
However (it was) at St Jean, Grand Forks, people weren’t accustomed to such floods; the one in ’97, it was frightening for the others. St Jean-Baptiste, it’s a way of life//.

According to Barnes this type of construction is due to the nature of unplanned speech where “pragmatic linking takes the place of formal integration” (1985:101). In other words, the speaker appears not to ‘think before he speaks’ – relying on pragmatic factors such as the context of the sentence to assist the hearer rather than on formal means.

The second type of no-anaphor LD suggested by Barnes (1985) is subdivided: the *first sub-type* concerns singling the out one case of a general group of possibilities. One possible example of this from the St Pierre data occurs where the topic of discussion is the flooding in St Jean-Baptiste (a neighboring town) and the speaker picks out a particular section of town. (Notice that the new (but accessible) topic des maisons is introduced by the ‘ya’ cleft, and une inondation... is brought into focus with the use of c’).

- 5.20 //Parce que ’y avait des maisons dans...dans la plus belle partie de St Jean, juste sur le côté d’la rivière, **c’était** une inondation toute les deux ans garantie,...(1:3:127-8).
*Because **there were** houses in...in the prettiest part of St Jean, just on the bank of the river, **it was** a flood every two years guaranteed,...*

The *second sub-type* is the most common no-anaphor LD type in the St Pierre data (50%), occurring mostly with the first person singular pronoun in the LD position and a c in the main clause, and this again matches Barnes’s observations. This “alternative referent function” (Barnes 1985:101), as the name suggests, switches the topic referent to which the proposition applies. This ties in with the comparative function of LDs outlined above, in the sense that the new referent is presented as a comparison with the previous one. Here are relevant examples from the St Pierre data:

- 5.21 a. E: ...Est-ce que vous pensez que vous allez habiter ici, au village?
L: Moi, ça dép...moi, ça dépend, comme, si que, si que je me fais, comme, transferer autre chose, ben, comme...
M: Moi, ça dépend avec qu’est-ce que je veux faire, ça. (1:1:62-5).

- E: ...Do you think you'll live here, in the village?
 L: Me, that dep...me, that depends, like, if (it happens) that, if that I, like, get transferred to something else, well, like...
 M: Me, that depends on what it is I want to do, that.
- b. R: Mes histoires, ils commencent après le, le...deux tières...
 F: Moi, ça ne va pas mal plus long mais... (1:3:146-7).
 R: My stories, they begin after the, the...two thirds...
 F: Me, it doesn't take that long but...
- c. E: Et quand vous étiez élevée, c'était l'français seulement dans la maison?
 B: Moi, quand j'étais jeune, on parlait seulement en français. Moi, quand j'ai élevé mes enfants, (on) parlait seulement en français.
 E: And when you were brought up, it was French only in the house?
 B: Me, when I was young, we only spoke in French. Me, when I raised my children, we only spoke in French..

The relation between the left detached personal pronoun moi and the following clause has subtle variations but in general is very loose from a formal point of view, while remaining pragmatically informative and interactionally fundamental, in terms of 'taking the floor' in the conversation.

As far as their syntactic structure is concerned, for the most part these examples have a straightforward syntactic structure consisting of LDP+clause. 5.21c is interesting, however, as it appears to have an LDP+clause unit which itself functions as the LDP for the following clause. Figure 15 illustrates this structure.

This alternative referent function description is also applicable to other pronouns in the no-anaphor LD examples in the St Pierre data, given in 5.22 below. In 5.22a, the speaker switches addressees for the intervening elle connaît pas le, switching back for the LD phrase, having established that hearer A does not yet know what he then begins to tell her. (The pronominal forms nous-autres and eux-autres will be examined further in section 5.2.3.

- 5.22 a. Des anglais...elle connaît pas le...nous-autres, i' fallu se battre pour sauver notre langue au Canada,... (1:2:81).
The English...she doesn't know...us-others, it was necessary to fight to save our language in Canada,...
- b. On était mieux, eux-autres, eux-autres, c'était pire. (1:3:56).
We were better-off, those others, those others, it was worse.

Returning to the case of first person singular pronominal moi, one example from the text (5.23) seems to differ from the usual pattern shown above. It appears to fall instead into the first sub-type of no-anaphor LD, in picking out a referent amongst possibilities, rather than introducing a contrasting referent.

- 5.2.3 Moi, ça, c'est à deux semaines avant, avant la date et mon père, il disait à ma mère, "on va aller tout d'suite à l'hôpital..." (1:3:86-7).
Me, that, it's two weeks before, before the date and my father, he said to my mother, "we're going to go to the hospital immediately..."

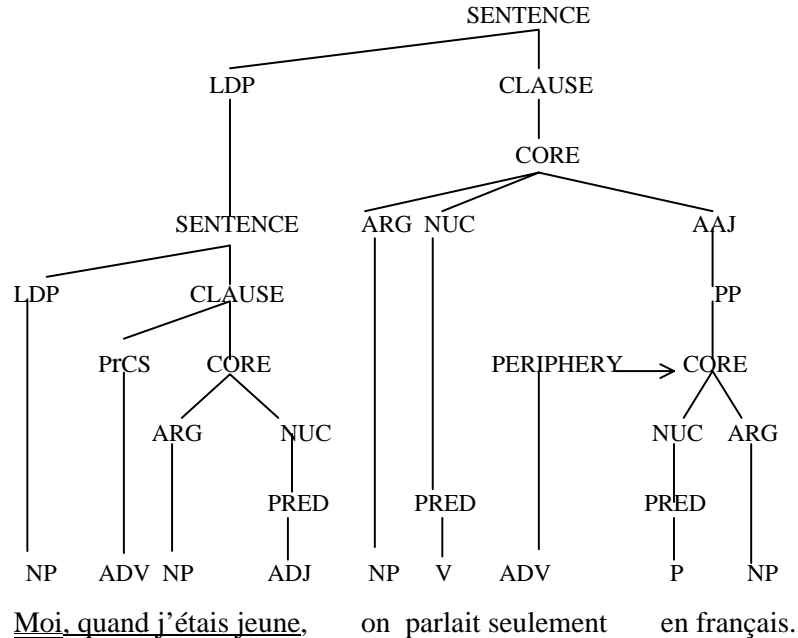

Figure 15: LSC for Sentence 4.20c

In fact, the speaker and her story were already the discourse topic before a little digression and interruption and so this use of LD seems to be more interactionally-motivated than pragmatically motivated; in other words, the **moi** serves to take control of the conversation, more than to introduce a new, contrasting referent. In common with English (Kim 1995) and Italian (Duranti & Ochs 1979), the speaker, by using this type of LD construction, “re-initiates a story after some intervening talk” (Kim 1995:277) and also “block[s] or...reduce[s] the access of others participating in the social interaction” (Duranti & Ochs 1979:405). In other words, the speaker seeks “the *establishment of some sort of communicative agreement* between the speech participants...” (Lambrecht 1981:63). This example also illustrates how indirect, in formal terms, the link can be between the pronoun and the subsequent clause in a no-anaphor LD.

5.2.3 ‘Case study’: First and Third Person Plural Pronouns

The previous sections have focused firstly on the anaphorical element in the main clause of a detached sentence; the second focus was on the pragmatic relationship between the detached constituent and the main clause, and also highlighted different types of detached sentences with no anaphor syntactically present. This section continues to examine pragmatic uses of detachment and focuses on the use of detached first person and third person pronouns, as evidenced in the St Pierre data. The use of the pronominal forms **nous-autres** and **eux-autres** (‘us/we-others’ and ‘them-others’) by these speakers correlates with the pragmatic and syntactic nature of LD and RD in an interesting way.

It has been well documented in the literature that the preference for the first person plural pronoun in spoken French is no longer **nous** but **on**, which has become the “regular, stylistically unmarked first person plural form” (Lambrecht 1981:41). In the St Pierre data, **nous** alone (*i.e.* with the **-ons** verb form) was not used at all. (Neither was the second person plural/formal pronoun **vous** used, except by the interviewer.) One possible reason for this omission is to

simplify verb paradigms which, with the use of **on** (and decreasing use of the second person plural/polite **vous**) become largely monosyllabic and frequently homophonous:

5.24	Je mange	[ʒəmãʒ]	I eat
	Tu manges (vous mangez)	[tumãʒ] ([vumãʒe])	You (sg./familiar) eat (you (pl./formal) eat)
	Il(/Elle) mange	[ilmãʒ]	He(/she) eats
	On mange (nous mangons)	[õmãʒ] ([numãʒõ])	We eat (we eat)
	Ils mangent	[ilmãʒ]	They eat

However, the situation is a little more complex: **on** tends to be used for general first person plural, in addition to its slightly more formal use for indefinite third person (e.g. 5.25d). Perhaps because of the latter possible interpretation of **on**, the form **nous, on** is often used for exclusive first person plural. In the St Pierre data, the referent(s) of **on** tend to be a more inclusive/nonspecific first person plural but this inclusivity does not usually extend to the hearer/interviewer (see 5.25a). It is possible for **on** to carry an exclusive sense (e.g. 5.25b, c) although, at least in 5.25b, the context of answering a question about the subject's family would assist in strongly favoring an exclusive reading for **on**, suggesting the context was enough to imply exclusive first person plural, without the need to add **nous**.

- 5.25 a. Ben, souvent on va faire venir le beurre du Québec; cette année on a tout, on a fait venir, euh, beaucoup de beurre qu'on a toute vendu au festival de voyageurs. (2:2:11-12).
Well, we often get the butter sent from Québec; this year we got it all, we got sent, uh, lots of butter that we sold out of at the 'festival de voyageurs'.
- b. Ma famille? Oui, ben, j'ai juste un frère, Raymond, on est tous les deux ici. Et on travaille ensemble, ça fait trente ans. (2:3:17-18).
My family? Yes, well, I only have one brother, Raymond, we're both here. And we work together, it's been 30 years.
- c. On a toujours fait nos voyages avec nos enfants. (2:3:33-34).
We've always done our travels with our children.
- d. ...c'est juste que, quand on est venu sur la terre, vraiment-là, ..., on a une bouche et deux oreilles, en fait qu', vraiment, i' faudrait écouter deux fois plus qu'on parle. (1:3:47-49).
...it's just that, when we arrive on earth, truly..., we have one mouth and two ears, which means that, truly, we should listen twice as much as we speak.

The **nous, on** form in French is used for exclusive first person plural, serving either to exclude the hearer or to include the hearer but exclude others; the **nous** seems to clarify the referents of **on**. **On**, by itself, cannot be detached – it has no tonic form; the tonic/ accusative form for its first person plural use is **nous**:

- 5.26 a. Nous, on va souvent au parc.
Us, we often go the park.
- b. *On, on va souvent au parc.

- c. Oui, je viens de St Pierre, mais ça ici c'est juste un village pour nous, pis là en ville c'est Winnipeg. (1:1:14).
Yes, I come from St Pierre, but this here is only a village for us, but there 'in town', it's Winnipeg.

In St Pierre, a third type of pronoun is frequently used for exclusive first person plural, namely **nous-autres** ('us/we-others'). This **nous-autres** form is used alone, or replacing **nous** in the **nous, on** pattern: **nous-autres, on**. Its use seems to convey an even greater, contrastive emphasis of exclusivity than **nous, on**, usually denoting referents belonging to the speaker's family or village (or ethnolinguistic group), and always excluding the interviewer. In other words, the shorter form **nous, on** can be exclusive in the traditional grammatical sense (*i.e.* to include others but exclude the hearer) or in a looser sense to include the hearer but exclude others. However, the range of possible referents for the form **nous-autres** is more restricted – it always excludes the hearer and it restricts the possible 'others' that are included. These 'others' tend to be the speaker's family or close community but not other groups of people. In the case of 5.27c and d below, the 'other(s)' are situationally present (but the pronoun still excludes the hearer, and others also present who are not from the same community).

This semantic connotation combines with the contrastive use of detachment constructions described above, and results in a dual method, semantic and syntactic, of marking contrastive exclusivity, as well as ensuring that the pragmatic topic is maintained. The following are examples from the St Pierre data:

- 5.27 a. Ben, nous-autres, on n'a pas été à...comme, j'ai des amis qui ont été affectés par l'inondation mais nous-autres, personnellement, non. (2:3:41-2).
Well, 'we-others', we weren't...like, I have friends who were affected by the flood but 'us-others', personally, no.
- b. ...une classe, 'y avait une trentaine d'élèves en classe pis nous-autres, on avait vingt-, vingt-cinq élèves à peu près. (2:4:19).
...one class, there were around 30 students in the class then 'we-others', we had about 20,25 students.
- c. M: Il faut qu'e' va chaque semaine.
 L: Comme, chaque jeudi, quasiment. Mais nous-autres, on va juste les fins de semaines ou pendant les vacances. (1:1:41-42).
M: It is necessary for her to go every week.
L: Like, every Thursday, more or less. But 'we-others', we only go at the weekend or during the holidays.

- d. G: ...on faisait ça seulement le lendemain p'ce que le lendemain //⁵et pis j'
 H: //Nous, on n'a pas le temps, nous-autres.
 G: Nous-autres, non: ça se vend aussi vite qu'on le fait. (1:2:42-44).
 G: ...we would only do that two days later, because two days later // and then I
 H: //Us, we don't have the time, us-others.
 G: Us others, no: it's sold as quickly as we make it.

The same observations as were made concerning **nous-autres** can be made about the use of the corresponding third person pronominal form **eux-autres** ('we/us-others') in the data; the contrastive function is evident (see 5.28 below). The detached **eux-autres** also seems to corefer with an element in subject position (or is a topic without anaphor) – for other positions, **les autres** or **des autres** are generally used (e.g. 5.28c and d).

- 5.28 a. On était mieux, eux-autres, eux-autres, c'était pire. (1:3:56).
We were better-off, those others, those others, it was worse.
- b. L: On utilise des différents mots comme...euh...des fois...euh...on est moins avancé dedans le français.
 E: Moins?
 L: Moins...Et pis, aussi, comme, eux-autres, i'...euh, comme, c'est comme à l'origine de...de français ou q'chose. (1:1:5-7).
L: We use different words like...uh...sometimes...uh...we are less advanced in French.
E: Less?
L: Less...And then, also, like, those others, they...uh, like, it's like at the origin of...of French or something.
- c. Quoi qu'à St Jean, Grand Fourches, les gens étaient pas habitués des inondations tellement; celle de '97, c'était effrayant pour les autres. St Jean-Baptiste, c'est une mode de vie//. (1:3:123-5).
Whatever (it was like) at St Jean, Grand Forks, people weren't accustomed to such floods; the one in '97, it was frightening for the others. St Jean-Baptiste, it's a way of life//.
- d. ...j'ai des amis ici là qui sont ici aujourd'hui là, on a peur de l'eau qui monte encore aujourd'hui là: ça rappelle des méchants souvenirs pour des autres. (2:3:46-7).
...I even have friends here who are here today, we're scared of the water that's rising again today: that brings back bad memories for the others.

These pronominal form **nous-autres** and **eux-autres** are used in addition to the other first person plural pronominal forms in French. I have not come across this pronominal form with such frequency in other varieties of French and I believe it can be, to some degree, attributed to the sociolinguistic and historical linguistic setting of the community of St Pierre, as outlined in this paper in section 3 above. It is plausible that the isolation and fight for cultural and linguistic

⁵ '// ' indicates that the speaker was interrupted; the same symbol in the following line indicates where the interrupter begins to speak.

continuity experienced to this day by the St Pierre community could influence their language in this way, not only in terms of an unconscious drift from standard French. It is also possible, given that the corresponding ‘them’ form **eux-autres** also exists in this language variety, that a conscious emphasis of the ‘us-them’ perception evident in many aspects of St Pierre culture and history is also present in their language variety.

On a pragmatic level, since the function of LD is to introduce a new (related) topic and the function of RD to ensure maintenance of a topic, it follows that the contrastive **nous-autres** would be found in LD position since it introduces a new, albeit related, topic. Note that in 5.27d (second line), left detached **nous, on** and right detached **nous-autres** are both used in the same sentence. Here, the shift of topic has already been achieved with the LD **nous, on** creating the possibility for **nous-autres** to occur in RD position to maintain this shift. In fact, this is the only example in the data of the **nous, on** form; it is possible the speaker felt it necessary to reinforce an exclusive meaning of **nous, on** with a right detached **nous-autres**. This might, then, also possibly be analyzed as a case of ‘repair’, which is often the motivation for RD structures in English (as described, for example, by Geluykens 1989). In the type of case illustrated by 5.27d, the pronoun in the main clause is clarified, not by a lexical NP, but by a pronoun with more specific referential possibilities.

The non-detached first person plural pronominal forms **nous** and **nous-autres** are found in one case each in non-subject, non-detached positions. This is too small a number to allow any conclusions to be made about the conditions for the use of each in this context; however, here are the two cases:

5.29 a. On faisait comme tout le monde faisaient alentours de nous-autres. C’est tout comme ça aussi. (2:4:16-17).

We did like everyone did around us-others. It’s all like that, too.

b. Oui, je viens de St Pierre, mais ça ici c’est juste un village pour nous, pis là en ville c’est Winnipeg. (1:1:14).

Yes, I come from St Pierre, but this here is only a village for us, but there ‘in town’, it’s Winnipeg.

The semantic distribution of the pronouns described in this section seems to be almost complementary in terms of the kinds of referents they can refer to and the syntactic contexts in which they can appear. It has also been shown that this is at least partly due to the placement of some of these pronouns in detached positions, where the characteristics of LD (such as to introduce a contrastive/comparative new topic) assist in creating these nuances of interpretation. Thus, in the case of **nous, on**, the **nous** seems to clarify the referents of **on**; the **nous** in left detached position does not merely corefer with the **on** but also helps determine the referents of **on**. This patterns with the description of ‘no-anaphor’ sentences with detached pronouns above, where it was observed that detached pronouns, while not determining the sentence topic as such, seek to narrow the sentence topic to its relation to the referent(s) of the pronoun. Here, the detached pronoun **nous** narrows the field of possible referents of the pronoun in the main clause that the proposition is about. As with detached pronouns with no anaphor, it “limit[s] the applicability of the main predication to a certain restricted domain” (Chafe 1976:50).

In this section (5.2), three characteristics of left detachment structures in French have been examined: in 5.2.1 the use of anaphoric **ce** was examined; in 5.2.2, ‘no anaphor’ LD structures

were discussed; finally, in 5.2.3, the case of first and third person plural pronouns and their interaction with left detachment was tackled. There is an interesting correlation between the three main aspects of left detachment in St Pierre French examined above. In each case, pragmatics plays a role in determining the syntactic shape of the sentence, seeming to override syntactic/semantic considerations in order to establish the focus structure of the sentence. Thus, for example, the use of **ce** as a pronominal element in the main clause of a detached sentence has been examined: the appearance of **ce** in such an environment would appear to be more connected to the expression of narrow (predicate) focus on the constituent that follows the **ce**, than to its relationship to the detached element (with which it may or may not corefer). In the case of the first person pronominal forms, the semantic meaning of the different forms interacts with the pragmatic connotations of left and right detachment to create numerous possibilities for the expression of first person plural referents.

It has thus been shown that interesting generalizations can be made at the pragmatic level which crosscut syntactic categories such as the presence or absence of an anaphoric element in the main clause and which may also interact with semantic meaning, as with pronoun referents.

5.3 Right Detachment Structures

The previous section focused mainly on left detachment, and this emphasis is reflected in much of the literature. However, right detached structures exhibit interesting characteristics and patterns of use, particularly when contrasted with left detached sentences, as this section will demonstrate.

5.3.1 RDs Syntactically Allied to the Main Clause

In general syntactic terms, a right detached constituent is generally viewed to be more syntactically allied to the main clause than a left detached element. Lambrecht shows that the presence or absence of case marking is one feature that distinguishes right detached constructions from left detached (Lambrecht 1981:78; 2001:22). This is considered evidence that the right detached element is more syntactically tied to the main clause, and it follows from the linear nature of the sentence. The syntactic role of the right detached element is already known when it is uttered, since it corefers with a cataphoric pronoun in the preceding clause whose syntactic role is given there (Lambrecht 1981:79). At the pragmatic level, just as the RD element is case-marked because the syntactic role is already determined at its moment of utterance, so the pragmatic role is also already predetermined.

This obviously contrasts with left detached constructions, where the detached element is uttered before the anaphoric pronoun. The role of the left detached element, and of its coreferring anaphor in the main clause, may not even have been decided at the time the LD is uttered. The following is the example of case-marking in RD constructions given by Lambrecht:

- 5.30 a. I-faut y-aller quand i-fait chaud, à la plage.
You have to go there when it's hot, to the beach. (1981:78, *except translation*).

This case-marking distinction is not visible in the St Pierre data since the RD elements all corefer with a subject role, which is unmarked for case in French.

5.3.2 RD Constituents Cannot be 'Unlinked'

Another feature of the closer ties between the right detached constituent and the main clause is the fact that the RD cannot be unlinked (Lambrecht 2001:23), that is, it cannot have no

coreferring cataphoric pronominal in the main clause. This contrasts with the no-anaphor LD cases described in the previous section. In actual fact, in some cases there may seem to be no cataphoric pronominal but this is simply because in fast speech, the pronoun is lost in the apparent haste to utter the focus of the sentence – this is particularly the case in somewhat idiomatic expressions such as **Je ne sais pas, moi**, e.g.:

- 5.31 ...c'est que q'chose que d'la tradition qui s'en va, qui s'en va, qui se faillir, 's'pas, moi. (1:3:8-9).
...it's something traditional that's disappearing, that's disappearing, that's failing, 'dunno', me.

However, other cases are not as explicable: the following extract from the St Pierre data in 5.32 contains an example of such an utterance:

- 5.32 Comme, pis, chaque business, chaque business, moi! – entreprise, i'font un, i'font un float, ah 'shoot'. (1:1:26-7).
Like, then, every business[Eng], every business[Eng], me! – business[Fr], they make a, they make a float[Eng], ah shoot!

The discourse topic at the time of this utterance is the annual 'frog folies' festival and the events that take place, specifically during the parade. The speaker slips into using the English word and recognizes her code-switching (she then slips again at the end of the utterance, hence the **ah shoot**). The **moi** carries the sense 'what am I saying?!/Just listen to me!' and carries the unaccented status characteristic of RD elements, thus is not the focus of the phrase. The phrase **chaque business, moi** is a backgrounded 'aside' before the speaker continues with her description. It is also not an interjection, since it does not "express a speaker's subjective judgment about a state of affairs" (Lambrecht 1996:337). There seems to be no reason not to interpret the **moi** in 5.32a as a particular type of parenthetical RD without cataphor.

5.3.3 Syntactic Structure of RD sentences

Thus, "unlike topics, which are discourse-bound, antitopics [RD] are clause-dependent phenomena, even though they always occur *after* the normal clause boundary" (Lambrecht 1981:80). The properties of RD structures outlined above have caused problems for transformational analyses: if the RD constituents are interpreted as outside the structure of the clause it is impossible for elements to appear after them in a sentence, as in 5.33, since that violates Ross's Right Roof Constraint (Cowper 1979:75).

- 5.33 Je l'ai vu, Pierre, chez ma cousine hier soir.
I him saw, Pierre, at my cousin's yesterday evening. (Cowper 1979:75).

Lambrecht (2001) suggests the following type of structure to account for RD:

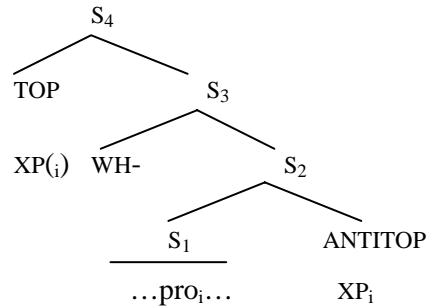
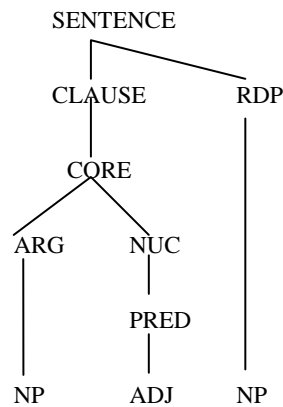

Figure 16: RD Syntactic Structure, proposed by Lambrecht (2001:25)

However, as has been noted, there are pragmatic explanations for the differences between LD and RD – if it is clear that left detached position (LDP) is not a mirror image of right detached position (RDP) in terms of its behavior and formal links with the main clause, then it may not be necessary to posit a separate level of attachment. This is particularly so since elements in LD and RD positions share many characteristics and the ways in which they differ would not appear to be without exception. Since these are pragmatically-motivated constituents, it is significant that LDP and RDP are both always outside the potential focus domain; this could be difficult to explain if they are placed ‘lower’ in a syntactic tree than WH- elements, for example, which can be in the potential focus domain.



i' est important, lui. (1:3:82). (He is important, him.)

Figure 17: LSC for Sentence 1:3:82

For reasons such as these, Role and Reference Grammar assigns right detached elements to an RDP position which syntactically mirrors the LDP position, to the right of the main clause. This is illustrated in Figure 17.

5.3.4 Position of RDP in Sentence – Interaction of Syntax and Information Structure

Another characteristic of so-called ‘anti-topic’ RD constructions outlined by Lambrecht (1981) that can be illustrated by the St Pierre data is that they do not necessarily fall at the end of a sentence, unlike LD topic constructions which must occur at the beginning (1981:82). For example see 5.33 above and 5.34 below:

- 5.34 Pis qu'on vit dans une mer d'anglophones, alors pour conserver notr' français, tout au cours des années, on a dû vraiment, nos grandparents, nos parents, et même nous-autres, travailler pour conserver notre langue.
(1:2:81-3)

Since we live(d) in a sea of English-speakers, so to conserve our French, all through the years, we really had to, our grandparents, our parents, and even us-others, work to conserve our language.

The sentence in 5.34, from the St Pierre data, is also illustrative of the maximum number of RD elements usually found, according to Lambrecht, namely three (1981:83).

Lambrecht further notes that while RD constituents need not necessarily occur at the end of the sentence, they must immediately follow the clause containing the cataphoric pronominal (2001:21); in other words, they “cannot be attached to the end of a higher clause” (Lambrecht 1981:82). The examples in French constructed by Lambrecht (1981) to illustrate this are repeated in 5.35:

- 5.35 a. Les films qui le-passionnent, Pierre, is-ont tous été interdits.
The films which excite-him, Pierre, they-have all been banned.
- b. *Les films qui le-passionnent is-ont tous été interdits, Pierre. (Lambrecht 1981:82).

The usefulness of these examples depends on the interpretation of the coreferring pronominal in the main clause. If, in 5.35b, the first NP **Les films qui le-passionnent** is interpreted as an left detached phrase, with **is-ont tous été interdits** as the main clause, one would not expect the right detached NP **Pierre** to be able to corefer with the other (left) detached element. If, as the punctuation suggests, we are intended to read it as only a right detached sentence (and the anaphor **is-** as a grammaticalized agreement marker), then the constraint applies. In fact, the examples are almost identical to data in Kayne (1975), where the troublesome pronoun **is** is omitted and the constraint is seen more clearly:

- 5.35 b' *Les films qui le passionnent tant ont tous été interdits, celui-là. (Kayne 1975:126).

This constraint on the RDP appearing immediately following the clause containing the cataphoric element is also borne out by all the RDs in the St Pierre data.

As already noted, LD and RD constituents are outside the potential focus domain in French. Lambrecht claims that the fact that LD and RD constituents are outside the potential focus domain causes a linear constraint on LD and RD constructions to appear before and after the focus of a sentence, respectively, as his example demonstrates:

- 5.36 a. Elle_i ne m'a pas rendu mon ARGENT, [Nicole]_i.⁶
She didn't give me my money back, Nicole.
- b. *Elle_i ne m'a pas rendu, [Nicole]_i, mon ARGENT. (Lambrecht 2001:19).

There is one instance in the data where this constraint might appear to be violated. It seems somewhat similar in structure to Lambrecht's example of an impossible sentence in terms of

⁶ See footnote 3; small capitals denote the 'focus accent'.

focus structure, yet is attested in the St Pierre data and repeated in 5.37a (using Lambrecht's notation). Other data (including from Lambrecht), examples of which are given in 5.37b and c, would also seem to disregard his constraint on pre-focal RD (although for these examples, the intonation is not known).

- 5.37 a. ...on; a dû vraiment, [nos grands-parents, nos parents, et même nous-autres]_i,
 TRAVAILLER pour CONSERVER notre langue. (1:2:82-3).
...all through the years we really had to, our grandparents, our parents, and even us-others, work to conserve our language.
- b. Les films qui le-passionnent, Pierre, is-ont tous été interdits.
The films which excite-him, Pierre, they-have all been banned. (Lambrecht 1981:82).
- c. L'idée qu'on doit l'écouter, ce maudit bloke, me fatigue à mort.
The idea that we have to listen to him, this damn Anglo, tires me to death.
 (Cowper 1979:75).

The right detached NPs in these examples are not merely parenthetical to the sentence; they are directly related to its meaning. They contribute to the understanding of the sentence by identifying the referent(s) of the cataphoric pronominal in the main clause. As further confirmation, this is one function that right detached phrases share with left detached elements – that is, the detached element, whether to the left or right, narrows the field of possible referents of the pronoun in the main clause that the proposition is about. It “limit[s] the applicability of the main predication to a certain restricted domain” (Chafe 1976:50).

With this established, it is possible to consider these sentences as exceptions to Lambrecht's constraint against pre-focal RDPs. In the sentences in 5.37, the RD is positioned before the actual (predicate) focus domain, not in the middle of it, as in 5.36b. A modification of the constraint to allow the RDP to precede the actual focus domain would still maintain the focal domain as an uninterrupted entity within the sentence, while accounting for the examples above. This would need to apply in order to account for these cases of predicate focus in 5.37, and this is most likely to be the type of focus concerned, since a main pragmatic motivation for RD (and LD) is to express predicate focus, by topicalizing the other argument in the sentence. Figure 18 illustrates this for 5.37a (some words abbreviated for reasons of space – see above for full sentence and translation):

It would appear that, in this case, the RD follows the core which contains the cataphoric pronominal element, rather than necessarily following the whole clause as described above. However, for 5.37a this conclusion would create the questionable, if not ungrammatical, 5.37a':

- 5.37 a'. ?*On a dû vraiment travailler, nos grands-parents, nos parents, et même nous-autres, pour conserver notre langue.

The evidence of sentences such as 5.38a-c creates the possibility that there is a superseding pragmatic constraint preventing non-focal elements from occurring post-verbally (or, rather, avoiding a post-verbal focal interpretation for the RD); it will be remembered that French exhibits a general constraint that limits the potential focus domain to the verb and postverbal elements.

The topical RD is thus required to occur before the verb **travailler**. (In the LSC, the two cores connect with a higher core node since the modal core operator **dû** shared by the two cores makes this a cosubordinate sentence).

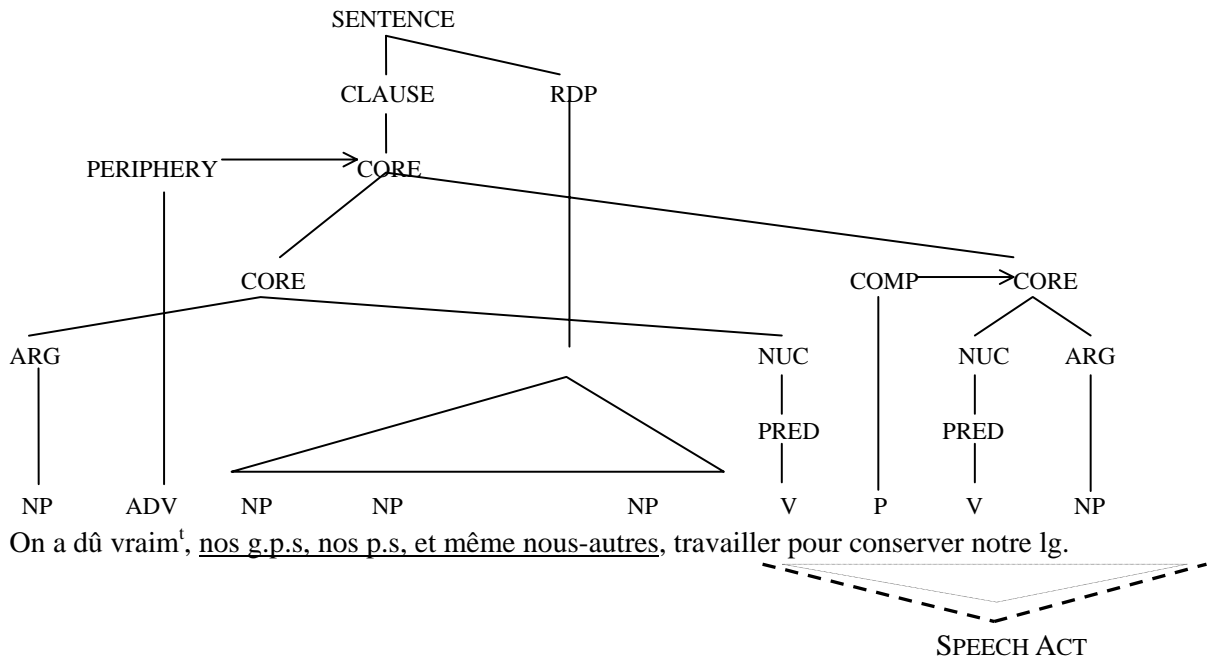

Figure 18: LSC for Sentence 5.37a

It can therefore be seen that the RDP's appearance in the middle of this sentence is a reflection of formal constraints interacting with pragmatic factors and, as with left detachment, the pragmatic rule appears to have the final say in accounting for the order and function of the elements in the sentence. This adaptation to the constraint also accounts for 5.37c, which is also from Canadian French (offered by Cowper (1979) – see above for translation).

Most of the examples in the literature give examples such as this, with relative or complement clauses to show how the right detached element must occur immediately after the clause containing the cataphoric element. They also serve to illustrate that right detached phrases may precede the focus domain. By not containing a subordinate clause, the example in 5.37a is a somewhat of a novelty.

In contrast to right detachment constructions, such a constraint requiring left detached phrases to immediately precede the clause (or core) containing the coreferring anaphor does not exist. In fact LD, as a topic-marking device in French, is sometimes specifically used as a strategy for maintaining the identity of the topic following a long phrase between the subject and the verb (5.38a, b), or following 'heavy' NPs (5.38c), as is noted by Cadiot (1992):

- 5.38 a. *Pierre, si tu continues comme ça, va te tuer!
 b. Pierre, si tu continues comme ça, il va te tuer!
Pierre_i, if you carry on like that, he_i will kill you!

- c. Les seuls changements perceptibles, et qui sont le nœud même de la pièce, (ce/??Ø) sont les masques qui se succèdent.
The only visible scene-changes, and which are the very intrigue of the play, (these/Ø) are the masks/ facial expressions which follow each other. (Cadiot 1992:75, except translations).

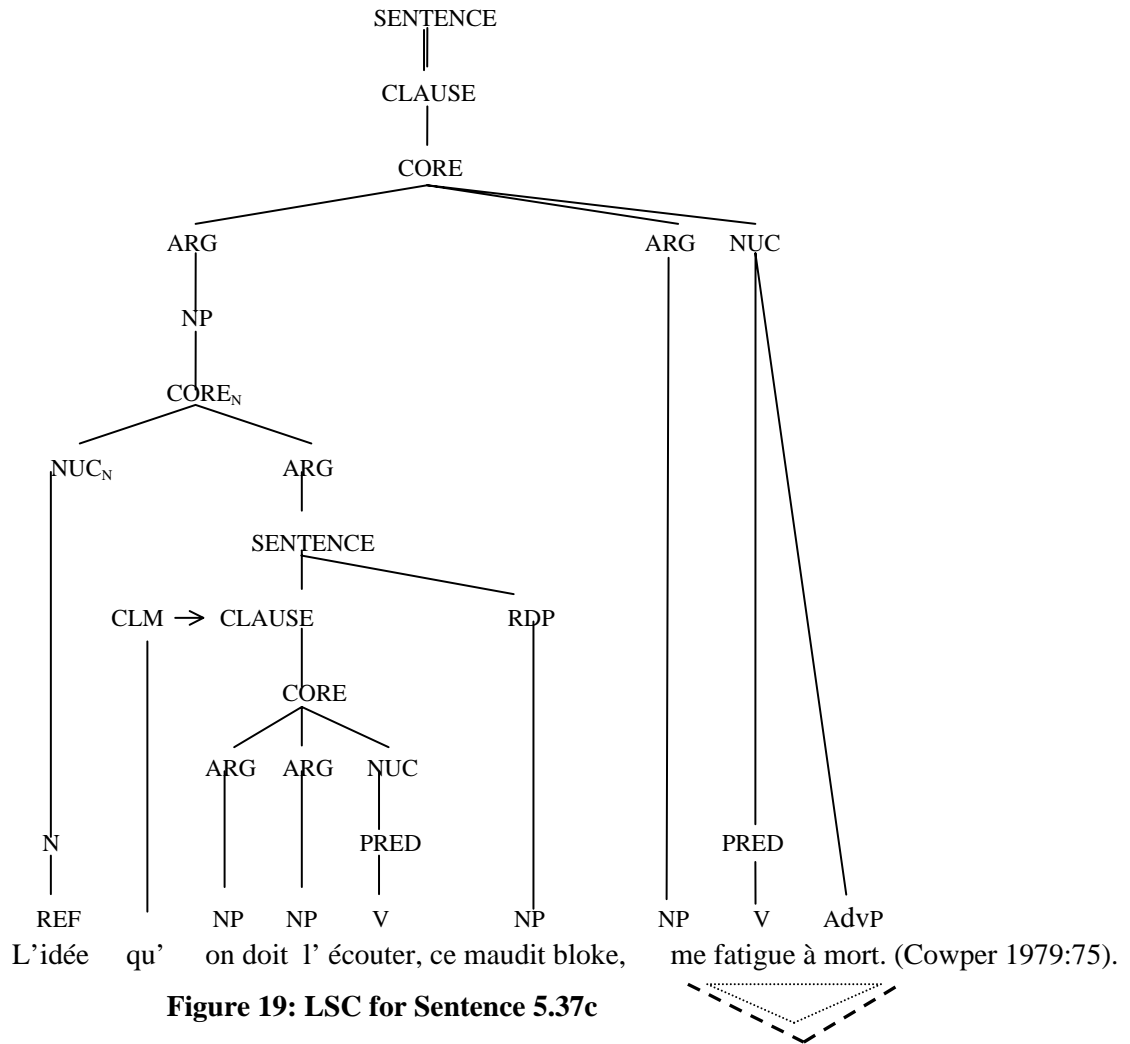

Figure 19: LSC for Sentence 5.37c

This function is also illustrated by the data from St Pierre:

- 5.39 a. Ce qu'ils disaient, c'est qu'les mères étaient tellement stressées pendant l'inondation qu'les enfants qui sont nés à cette période-là, i'étaient...euh...énorm, énormément agités... (1:3:107-8).
What they said, was that the mothers were so stressed during the flood that the children that were born during this particular period, they were...uh...great, greatly disturbed...
- b. L'hôpital la plus proche pour ma grand-mère, c'était à Manchester... (2:3:23).
The nearest hospital for my grandmother, it was in Manchester.

5.3.5 Intrasentential Pronominal Coreference

Another issue concerning right detached sentences that is explored in the literature is intrasentential pronominal coreference. Transformational accounts of detached phrases have encountered problems when accounting for intrasentential pronominalization, particularly when a lexical NP follows its coreferring pronoun, as in right detached sentences. Cowper (1979) tries to apply Jackendoff's (1972) rule of coreference for English to Canadian French: this rule creates coreference between an NP and a pronoun "unless the pronoun precedes and commands the NP" (cited in Cowper 1979:74). In a transformational framework, Barnes cannot resort to a $S \rightarrow S$ NP-type structure (which violates X-bar convention) to account for RD, nor to positing an extra-clausal position for the 'dislocated' element, for reasons given above (section 2). She hesitantly suggests a new phrase category called 'reprise' which is in between the two and has its own rule of coreference (Cowper 1979).

The reasoning behind positing a clause-external assignment for RDPs has been accounted for above. Thus, in Role and Reference Grammar, while RDPs have been shown to be more 'clause-dependent', left and right detached phrases are outside the clause, and so a more concise principle of intrasentential pronominal coreference is made possible. This is given in 5.40:

- 5.40 Principle governing intrasentential pronominalization
Coreference is possible between a lexical NP and a pronoun within the same sentence if and only if
- a. the lexical NP is outside of the actual focus domain, and
 - b. if the pronoun is in a syntactic argument position and precedes the lexical NP, there is a clause boundary between the pronoun and the lexical NP. (Van Valin & LaPolla 1997:227).

Detached constituents are always outside of the focus domain by virtue of their position outside the clause, as explained in section 4.2. In addition, where a right detached lexical NP follows its cataphoric pronoun in a sentence, there is a clause boundary between the former and latter, again due to the extra-clausal position of the RD. This is illustrated by Figure 17 above, where **i** and **lui** corefer to the same referent.

Lambrecht (2001) argues that coreference for LD constructions is pragmatically determined, rather than syntactic or semantic. Thus, there is the possibility of a dual interpretation of a sentence such as 5.41⁷, one with coreference (5.41a), one with no anaphor (5.41b), where 5.41b is given the slightly awkward context "My parents don't care about the Italians in general, but the Romans, they are crazy, they absolutely love them" (Lambrecht 2001:24).

- 5.41 a. [The Romans]_i, they_i are crazy.
b. [The Romans]_i, they_j are crazy. (Lambrecht 2001:24).

This leads Lambrecht to conclude what has already been illustrated in section 5.2.1, "from a strictly grammatical point of view, all TOP [LD] phrases are unlinked" (Lambrecht 2001:24).

⁷ As per the source, square brackets denote the detached constituent.

5.3.6 Other Discourse Factors – Comparison with LD

There are other factors also affecting the use of RD structures in French that are discourse-related. Lambrecht argues that the choice of an LD or RD construction for a sentence is influenced by the “iconic ordering principle...while the order topic-comment signals announcement or establishment of a new topic relation between a referent and a predication, the order comment-topic signals continuation or maintenance of an already established relation” (Lambrecht 2001:27). The following examples from the St Pierre data illustrate this distinction: in 5.42a the RD contains a repeat of the subject pronoun, thus serving to maintain/re-establish it as a topic (**la flood** is also part of the topic, but it is the other speaker’s experience of the flood, specifically, that is requested). In 5.42b the conversation had drifted from the original question and the RD serves to return to the original topic (rather than introduce a new topic):

5.42 a. La flood en ’50, t’en rappelles, toi? (1:3:192). (Follows pause in conversation).

The flood in ’50, (do) you remember it, you?

b. E: Et ici, en ville, il y a grandes choses à faire?

M: En ville ou à St Pierre?...quel...Tu parles d’ici ou en ville?

E: Tu viens pas de St Pierre?

M: Oui, je viens de St Pierre, mais ça ici c’est juste un village pour nous, pis là ‘en ville’ c’est Winnipeg.

E: OK, dans le village.

L: Moi, j’aime ça, vivre à St Pierre, p’ce que...euh c’est pas, euh, si gros, ça fait qu’tu, tu peux faire plus de choses comme, des f... comme on a la cabane à sucre pis on a aussi le, les folies grenouilles. (1:1:11-17).

E: And here, in town, is there much to do?

M: In town or in St Pierre?...which...Are you talking about here or in town?

E: You’re not from St Pierre?

M: Yes, I come from St Pierre, but this here is only a village for us, but there ‘in town’, it’s Winnipeg.

E: OK, in the village.

L: Me, I like that, to live in St Pierre because...uh, it’s not, uh, so big, what I mean is that you, you can do many things like, the...like we have the ‘cabane à sucre’ and then we also have the, the ‘frog folies’.

However, there is at least one example from the text where the referent of RD element is a ‘new-but-related’ topic, circumstances which would usually inspire a left detached structure. In 5.44 below, the general topic is ‘things to see and do in Montréal’ and the most recent topic is the Olympic stadium. However, the referent of the RD element (the view from the top of the stadium) could not be expected by the speaker to be ‘given’, in the sense of being something “the speaker assumes to be in the consciousness of the addressee at the time of the utterance” (Chafe 1976:30). In that way, it offers a new, albeit accessible, topic rather than the usual maintenance of the current topic associated with the RD structure.

5.43 M: ...Et pis c’est...’y a des, ’y a des affaires là-bas que tu trouves juste là-bas pis pas ici.

L: Comme le stade olympique.

M: Ouais ça on a été voir. Ça c’est fantastique, la vue d’en haut. (1:1:49-51).

M: ...And it's...there are, there are things there that you only find there, and not here.

L: Like the Olympic stadium.

M: Yeah, we went to see that. That, it's fantastic, the view from up there.

It could be argued that this is a case of 'repair' or 'afterthought' if there were a pause between the main clause and the detached element. However, this is not the case.

What is also less than evident from the data is Lambrecht's (1981) statement (concerning New Standard French) that "antitopics can never have a contrastive and even less an emphatic function" (1981:86). He bases this argument on the impossibility of intonationally stressing a right detached element, just as an anaphoric pronoun cannot be stressed in a sentence. While strong intonational contrast may not be possible, a comparative function in the sense of Barnes (1985, referring to LD) is evident in the St Pierre data. The exclusive, and thereby somewhat contrastive nature of **nous-autres** has already been discussed and is used in two sentences in the data in RD position (repeated in 5.44a and b with relevant context). In these examples, there is a clear attempt on the part of the speaker to at least compare the referents with individuals or groups previously mentioned in the discourse. 5.44a seems to be of a more strongly contrastive nature than 5.44b.

- 5.44 a. G: Et puis, quand on était plus jeune, on avait un petit...moule, fait comme un livre de beurre, qu'on mettait dedans, et pis le len...on faisait ça seulement le lendemain p'ce que le lendemain // et pis j'

H: //Nous, on n'a pas le temps, nous-autres.(1:2:41-3)

G: So, when we were younger, we had a little...mold, (it) made like a pound of butter, that we put inside, and then two day...we would only do that two days later, because two days later // and then I

H: Us, we don't have the time, us-others.

- b. Des anglais...elle connaît pas le...nous-autres, i' fallu se battre pour sauver notre langue au Canada, euh; pis qu'on vit dans une mer d'anglophones alors pour conserver notr' français, tout au cours des années on a dû vraiment, nos grandparents, nos parents, et même nous-autres, travailler pour conserver notre langue. Alors des anglais, c'est des ennemis! (1:2:81-4).

The English...she doesn't know the...us-others, it was necessary to fight to save our language in Canada, uh; since we live in a sea of English-speakers so to conserve our French, all through the years we really had to, our grandparents, our parents, and even us-others, work to conserve our language. And so the English, they're the enemies!

5.44b also serves as an example of a RD construction containing an adverb (**même** 'even') which Lambrecht states cannot occur in NSF, for reasons which are not fully explained (1981:92).

In addition to these cases, there are three examples in the St Pierre data of RD **moi** where the use of the pronoun in the detached construction serves in part to distinguish the referent (the speaker) from others situationally present and/or previously mentioned; these are given in 5.45. The first two involve the almost idiomatic expression **je ne sais pas, moi** ('I wouldn't know') often considerably condensed in fast speech, as in 5.45a:

- 5.45 a. Peut-être qu'on dira(?) là en un autre couple d'années, c'est que q'chose que d'la tradition qui s'en va, qui s'en va, qui se faillir, 's'pas, moi.(1:3:8-9).
Maybe we'll say in another couple of years, it's something traditional that's disappearing, that's disappearing, that's failing, 'dunno', me.
- b. F: Oui, c'est ça. J'ai plus rien à dire.
R: Tu n'as plus rien à dire –c'est fini. 'Y a tout ben un certain âge peut-être qui arrive qu'y a un gars qu'il n'y a plus rien à dire; j'en ne sais pas, moi.
N: On n'est pas là.(1:3:18-21).
F: Yes, that's it. I have nothing more to say.
R: You have nothing more to say – it's finished. Well, maybe there's a certain age you get to when a guy has nothing more to say; I don't know about that, me.
N: [Addressing R] We're not there.
- c. Ma mère, elle faisait des couvre-pieds seulement qu'elle faisait pas les patrons comme, comme j'fais, moi. (2:4:7-8).
My mother, she only made foot-covers, she didn't make patterns like, like I make, me.

In 5.45a, the speaker seems to be suggesting that while he doesn't really know for sure what he's talking about, others may well know. In 5.45b, with the immediate discourse context included, the speaker's sarcastic 'I wouldn't know' (about running out of things to say when he is old) is clear, as he humorously contrasts himself with his friend F, thereby implying F would know about such things. It is also incidentally interesting that, in 5.45b, N uses the vaguer first person plural pronoun **on** although the referents are clearly herself and R, excluding F. In 5.45c, the clearest contrastive use of RD is found, where the speaker compares her craft with her mother's.

5.4 Left Detachment and Right Detachment in the Same Sentence

This overview of the differences and similarities between left and right detachments can be illustrated by examining sentences in which both constructions occur simultaneously. Some examples, from the St Pierre data, of left detachment and right detachment within the same sentence follow in 5.46. In the first case (5.46a), the subject is right detached and the object is left detached; in 5.46b that situation is reversed. In the other two cases, it is the same (subject) element that corefers with both the left and the right detached phrase:

- 5.46 a. Moi, j'aime ça, vivre à St Pierre... (1:1:16).
Me, I like that, to live in St Pierre...
- b. La flood en '50, t'en rappelles, toi? (1:3:192).
The flood in '50, do you remember it, you?
- c. Ça c'est fantastique, la vue d'en haut. (1:1:51).
That, it's fantastic, the vue from up high.
- d. Nous, on n'a pas le temps, nous-autres. (1:2:43).
Us, we don't have the time, us-others.

In 5.46a and b, the detached elements to the right and the left refer to different entities. In 5.46a, the fact of living in St Pierre, which is the right detached element in the sentence, is the sentence topic. However, in 5.46b, the left detached element, the flood in 1950, is the sentence topic. In each case, the pronoun indicates that the sentence concerns the sentence topic as it relates to the referent of that pronoun – whether left or right detached, the pronoun narrows the scope of the sentence topic, as has been repeatedly shown above.

It has been demonstrated in this section that the basic, topicalizing role of both left and right detached elements is similar. However, it is significant that right detached phrases reflect interesting interactions between pragmatic and syntactic constraints which differ from those which concern left detached phrases. It has been shown how RD elements are more syntactically tied to the main clause than LD constituents: the syntactic and pragmatic role of the RD referent has been determined before it is uttered. This stands in contrast to LD structures where such roles may not have been determined at the time of their utterance. In addition, while RD elements must follow the clause containing their cataphoric pronominal element, this need not mean they must fall at the end of the sentence (unlike LD, which must occur at the beginning). Finally, it was shown that the pragmatic role of RD tends to be to maintain a given topic, rather than to present a contrastive or comparative topic, which is the general role of LD structures. However, there are exceptions to this trend in the data.

These differences between the characteristics and behavior of LD and RD structures need to be specified since they do not follow from the syntactic representations of the layered structure of the clause in Role and Reference Grammar – the LSC structures for left detached position and right detached positions are mirror images.

SECTION VI

CONCLUSION

This paper has provided a different approach to the study of detachment constructions in French which has begun to illuminate new correlations between information structure and syntactic structure. Rather than looking at the changing nature of the coreferencing relationship between the referent of the left detached constituent and the pronominal element in the main clause, a main focus has been on the participation of the pronominal in the *c'est* phrase and the conditions under which this form appears to carry out the pragmatic function of conveying narrow focus on the (predicative) element that follows.

With the nature, and even existence, of coreference between the LD element and the pronominal in question, so-called 'no-anaphor' LDs were examined and there were shown to be similarities in pragmatic function between types of LD with and without anaphor in the main clause. These similarities were seen, in some cases, to override considerations of grammatical agreement.

Similarities between no-anaphor LDs and LDs with anaphor were illustrated with a study of the use of first person plural (and also third person plural) pronouns, which exhibit interesting behavior in the St Pierre variety of French. In addition, rarely-mentioned right detached structures were examined in terms of the interaction between syntax and information structure.

In all of these cases it was found that approaching the analysis from a pragmatic rather than semantic standpoint yielded an easier account of the facts. In each case, pragmatics has a large part to play in determining the syntactic form of the sentence. Barnes (1985) states in her conclusion, "rather than looking at certain semantic properties of LD-expressions as evidence of a constraint on the LD construction, it may in some cases be more appropriate to view those properties as a consequence of the syntactic and pragmatic status of LD-expressions" (Barnes 1985:94). This study has shown that it is not only the pragmatic status of the LD (or RD) expressions that need to be studied but also the pragmatic function of other parts of the sentence and the way these two interact.

Role and Reference Grammar theory has proved to be helpful in accounting for this interaction. Firstly, the breakdown of the core of the sentence into the nucleus and its arguments allows clauses, as well as verbs and NPs, to be labelled as the predicate of the nucleus. Secondly, the distinction employed in Role and Reference Grammar between different types of focus has been useful in describing the pragmatic functions of different detachment and cleft structures in French: potential and actual focus domains can be plainly illustrated on the syntactic tree structures. Thirdly, the treatment of detached structures as they appear, in left detached position or right detached position, rather than as the 'moved' surface manifestation of a different underlying sentence, permits a simpler analysis and tree structure. For French in particular, it seems intuitively logical to treat these detached structures in this way as the detached constructions have been shown clearly to have different pragmatic functions from each other and from sentences with a traditional SVO word order.

As well being innovative in using Role and Reference Grammar and in terms of its approach to detachment structures, this paper has also contributed to the study of detachment structures by examining their occurrence in a dialect of Manitoban French. Lambrecht observed that "[t]he

main characteristics of NSF...do not seem to be limited to a particular social class” (Lambrecht 1981:13). Barnes (1985) also notes that to claim that LD is current in spoken French requires that it be present in “the speech of speakers of varying socio-economic standing. Confirmation of this prediction requires careful comparison of corpora such as this one and others where the variety of French is further removed from the standard language” (Barnes 1985:114). While the corpus of data for this study is relatively small, and further study should be carried out, it is an initial contribution aimed at broadening the spectrum of varieties of French considered in academic studies.

There has been much discussion in the literature over whether the basic word order of French is diachronically shifting. Lambrecht (1980, 1981, for example) argues that modern standard French has more than one basic word order – SVO and the detached constructions. Other studies seek to reanalyze the coreferential pronominal elements in the main clause of a detached sentence as agreement markers on the verb, and emerge with quite divergent predictions ranging from suggesting a basic VSO word order (*e.g.* Harris 1978, and the more hesitant Matthews 1988), to a less radical topic-prominent proposition (*e.g.* Ashby 1982). Still others present a strident defense of the SVO word order (*e.g.* Bichakjian 1988). Van Valin goes as far as to suggest that “French seems to be heading toward...[a] prohibition against preverbal focal elements” (Van Valin 1999:8). While a contribution to this debate is beyond the scope of this paper, it is hoped that the data included will be useful in further assessment of any trends that may be occurring in oral French, wherever it is spoken.

REFERENCES

- Ashby, William, J. 1982. The drift of French syntax. *Lingua* 57:29-46.
- Ashby, William J. 1999. Au sujet de quoi? La fonction du sujet grammatical, du complément d'objet direct, et de la construction présentative en français parlé. *The French Review* 72:3.481-493.
- Auger, Julie. 1995. A Morphological Analysis of Québec Colloquial French Pronominal Clitics. *Chicago Linguistic Society* 31:2 Parasession on Clitics.32-49.
- Barnes, Betsy K. 1985. *The Pragmatics of Left detachment in Spoken Standard French.* Amsterdam and Philadelphia: John Benjamins.
- Barnes, Betsy K. 1988. Pragmatic Exploitation of NP c'est que S in Conversational Discourse. *Chicago Linguistic Society* 24.32-46.
- Bichakjian, Bernard H. 1988. The current evolution of French word order: claims and caution. *Georgetown University Round Table* 1988:37-52.
- Cadiot, Pierre. 1992. Matching syntax and pragmatics: a typology of topic and topic-related constructions in spoken French. *Journal of Linguistics* 30.57-88.
- Chafe, Wallace L. 1976. Givenness, contrastiveness, definiteness, subjects and topics. *Subject and Topic*, ed. by Charles Li, 25-55. London: Academic Press.
- Chomsky, Noam. 1965. *Aspects of the theory of syntax.* Cambridge, Mass.: M.I.T. Press.
- Cinque, Guglielmo. 1977. The movement nature of left dislocation. *Linguistic Inquiry* 8:1.397-411.
- Cowper, Elizabeth A. 1979. Right-dislocation in Franco-Canadian. *Chicago Linguistic Society* 5.70-78.
- Deshaies, Denise. 1981. *Le français parlé dans la ville de Québec – une étude sociolinguistique.* Québec: Centre international de recherche sur le bilinguisme.
- Duranti, Alessandro & Elinor Ochs. 1979. Left-Dislocation in Italian Conversation. *Syntax and Semantics 12: Discourse and Syntax*, ed. by T. Givón, 377-416. New York: Academic Press.
- Fox, Cynthia A. 1991. A discriminant analysis of Yes-No questions in Quebec French. *Word* 42:3.277-293.
- Geluykens, Ronald. 1989. Referent-tracking and Cooperation in Conversation: Evidence from Repair. *Chicago Linguistic Society* 25:2 Parasession on Language in Context.65-76.
- Harris, Martin. 1978. *The evolution of French syntax: a comparative approach.* London: Longman.
- Hirschbühler, Paul. 1975. On the source of lefthand NPs in French. *Linguistic Inquiry* 6:1.155-165.
- Kayne, Richard S. 1975. *French Syntax.* Cambridge, Mass.: M.I.T. Press.
- Kim, Kyu-hyun. 1995. WH-clefts and left-dislocation in English conversation. *Word Order in Discourse. Typological Studies in Language*, ed. by Patricia Downing & Michael Noonan, 276-296. Amsterdam & Philadelphia: John Benjamin.
- Lambrecht, Knud. 1980. Topic, French style: Remarks about a basic sentence type of modern non-standard French. *Berkeley Linguistic Society* 6.337-360.
- Lambrecht, Knud. 1981. *Topic, Antitopic and Verb Agreement in Non-standard French.* Amsterdam and Philadelphia: John Benjamins.

- Lambrecht, Knud. 1984. A pragmatic constraint on lexical subjects in spoken French. *Chicago Linguistic Society* 20.239-256.
- Lambrecht, Knud. 1986. Pragmatically motivated syntax: Presentational cleft constructions in spoken French. *Chicago Linguistic Society* 22:2 Parasession on pragmatics and grammatical theory.115-126.
- Lambrecht, Knud. 1987. On the status of SVO sentences in French discourse. *Coherence and Grounding in Discourse. Typological Studies in Language* 11, ed. by R. Tomlin, 217-261. Amsterdam and Philadelphia: John Benjamin.
- Lambrecht, Knud. 1996. On the formal and functional relationship between topics and vocatives. Evidence from French. *Conceptual Structure, Discourse and Language*, ed. by Adele Golberg, 267-288. Stanford: CSLI.
- Lambrecht, Knud. 2001. Dislocation. *Language Typology and Language Universals. Vol. 2, Article #80.* (Series Handbücher zur Sprach- und Kommunikationswissenschaft.) ed. by Martin Haspelmath, Ekkehart König, Wulf Österreicher & Wolfgang Raible. Berlin, New York: Walter de Gruyter.
- Larsson, Eva. 1979. La Dislocation en Français: Étude de syntaxe générative. *Études Romanes de Lund* 28.
- Matthews, Stephen J. 1988. French in flux: typological shift and sociolinguistic variation. *Georgetown University Round Table* 1988:188-203.
- Reinhart, Tanya. 1982. *Pragmatics and linguistics: an analysis of sentence topics.* Bloomington: Indiana University Linguistics Club.
- Van Valin, Robert D. 1999. A Typology of the Interaction of Focus Structure and Syntax. *Typology and the Theory of Language: From Description to Explanation*, ed. by E. Raxilina & J. Testelec. Moscow.
- Van Valin, Robert D. and Randy J. LaPolla. 1997. *Syntax: Structure, meaning and function.* Cambridge: Cambridge University Press.