

## INFORMATION TO USERS

This was produced from a copy of a document sent to us for microfilming. While the most advanced technological means to photograph and reproduce this document have been used, the quality is heavily dependent upon the quality of the material submitted.

The following explanation of techniques is provided to help you understand markings or notations which may appear on this reproduction.

1. The sign or "target" for pages apparently lacking from the document photographed is "Missing Page(s)". If it was possible to obtain the missing page(s) or section, they are spliced into the film along with adjacent pages. This may have necessitated cutting through an image and duplicating adjacent pages to assure you of complete continuity.
2. When an image on the film is obliterated with a round black mark it is an indication that the film inspector noticed either blurred copy because of movement during exposure, or duplicate copy. Unless we meant to delete copyrighted materials that should not have been filmed, you will find a good image of the page in the adjacent frame. If copyrighted materials were deleted you will find a target note listing the pages in the adjacent frame.
3. When a map, drawing or chart, etc., is part of the material being photographed the photographer has followed a definite method in "sectioning" the material. It is customary to begin filming at the upper left hand corner of a large sheet and to continue from left to right in equal sections with small overlaps. If necessary, sectioning is continued again—beginning below the first row and continuing on until complete.
4. For any illustrations that cannot be reproduced satisfactorily by xerography, photographic prints can be purchased at additional cost and tipped into your xerographic copy. Requests can be made to our Dissertations Customer Services Department.
5. Some pages in any document may have indistinct print. In all cases we have filmed the best available copy.

University  
Microfilms  
International

300 N. ZEEB RD., ANN ARBOR, MI 48106

8127707

STUCKY, SUSAN U.

WORD ORDER VARIATION IN MAKUA: A PHRASE STRUCTURE  
GRAMMAR ANALYSIS

*University of Illinois at Urbana-Champaign*

PH.D. 1981

University  
Microfilms  
International 300 N. Zeeb Road, Ann Arbor, MI 48106

Copyright 1981

by

Stucky, Susan U.

All Rights Reserved

WORD ORDER VARIATION IN MAKUA:  
A PHRASE STRUCTURE GRAMMAR ANALYSIS

BY

SUSAN U. STUCKY

B.A., Bethel College, 1971  
M.A., University of Kansas, 1976

THESIS

Submitted in partial fulfillment of the requirements  
for the degree of Doctor of Philosophy in Linguistics  
in the Graduate College of the  
University of Illinois at Urbana-Champaign, 1981

Urbana, Illinois

UNIVERSITY OF ILLINOIS AT URBANA-CHAMPAIGN

THE GRADUATE COLLEGE

April 22, 1981

WE HEREBY RECOMMEND THAT THE THESIS BY

SUSAN U. STUCKY

ENTITLED WORD ORDER VARIATION IN MAKUA: A PHRASE STRUCTURE

GRAMMAR ANALYSIS

BE ACCEPTED IN PARTIAL FULFILLMENT OF THE REQUIREMENTS FOR

THE DEGREE OF DOCTOR OF PHILOSOPHY

Charles W. Kisseberth

Director of Thesis Research

Therese Quinn

Head of Department

Committee on Final Examination†

Charles W. Kisseberth

Chairman

Elisabeth

Peter Joly

Michael Gertowicz

† Required for doctor's degree but not for master's.

WORD ORDER VARIATION IN MAKUA:  
A PHRASE STRUCTURE GRAMMAR ANALYSIS

Susan U. Stucky, Ph.D.  
Department of Linguistics  
University of Illinois at Urbana-Champaign, 1981

The purposes of this dissertation are two-fold. The first is to examine one aspect of the syntax of a largely undescribed Bantu language, Makua. The aspect under consideration is the syntactic property loosely (and perhaps ill-advisedly) termed free word order. The second purpose is to provide a formal treatment of this part of Makua syntax. The analysis is cast within that version of phrase structure grammar as developed by Gerald Gazdar at the University of Sussex. This version of phrase structure grammar embodies two trends in linguistic theory: 1) a movement away from transformations and towards base-generation and 2) the incorporation of a compositional semantics of the sort advocated by Montague and others.

It is argued that even though Makua exhibits a certain degree of order freedom, it is inappropriate to analyze this order as free at the word level or free at the constituent level. Rather, certain constituents and words enjoy freedom while others do not. The analysis proposed consists of a set of rules with specific properties which depend, in part, on the existence of certain constituents, e.g. the presence of a verb phrase in some orders but not in others. Other rules are motivated by constraints on the distribution of such constituents as sentential complements and infinitive complements (but not infinitives themselves). Additional supporting evidence for the separate rules comes from the formalization of verb agreement and from the analysis of the syntax of relative clauses. It is concluded that this multi-rule approach renders both scrambling rules or linear concatenation rules not only

superfluous for an analysis of Makua syntax, but inadequate as well.

It is of no small importance to syntactic theory that a general account of order can be given in a grammar consisting entirely of phrase structure rules, because such grammars were thought (by early advocates of transformational grammars) to be not only inelegant, but inadequate on descriptive grounds. In addition, the kind of analysis provided for Makua is suggestive of a general approach to order freedom, which, unlike other formal proposals for such languages, requires the addition of no fundamentally different rule type (e.g. scrambling transformations (Ross (1967)) or linear concatenation rules (Hale (1979) and Lapointe (1980))). Because linguistic theories tend to be ephemeral in nature, the most lasting contribution may well be the presentation of data from a heretofore unstudied language. It is hoped that the thesis presents a significantly large body of data to aid in our general understanding of human language.

To My Parents  
for both love  
and encouragement

## ACKNOWLEDGEMENTS

With a deep sense of gratitude, I take this opportunity to extend my thanks to those who supported this endeavor. My greatest debt is to John Wembeh Rashid who provided the Makua data for this thesis. His unfailing patience and his tremendous insight into his language made the data gathering a very satisfying experience. Special thanks are also due to two members of my committee: first, to Chuck Kisseberth who provided not only the research funds for the project but the analysis of tone and morphology in Makua, along with countless hours of discussion of the syntactic analysis, and secondly, to Jerry Morgan for his (always) stimulating discussions, in particular for those discussions related to word order and Phrase Structure Grammar. It is safe to say, I think, that without these three individuals, this thesis would never have been written.

Thanks are also due to Gerald Gazdar and Geoffrey Pullum who made comments on an earlier version of this thesis, to Ivan Sag for his help in formulating the agreement analysis, and to the other members of my committee, Eyamba Bokamba, Peter Cole, and Michael Kenstowicz, all of whom contributed in the way of discussion and comments.

Finally, I would like to thank my colleagues and friends at the University of Illinois and at the University of Massachusetts for their encouragement and stimulating conversations. A special note of thanks to Martha Wright, who typed beautifully a very messy draft and to Peter Sells, who aided in proofreading.



## TABLE OF CONTENTS

	Page
ABSTRACT. . . . .	iii
DEDICATION . . . . .	.v
ACKNOWLEDGEMENTS. . . . .	vi
TABLE OF CONTENTS . . . . .	vii
TABLE OF ABBREVIATIONS . . . . .	xi
CHAPTER I: INTRODUCTION. . . . .	.1
CHAPTER II: BASIC MAKUA. . . . .	.9
1. Introduction . . . . .	.9
2. Nouns. . . . .	.9
3. Verbs. . . . .	14
3.1 Neg <sub>1</sub> . . . . .	15
3.2 SA. . . . .	16
3.3 T/A . . . . .	17
3.4 OA. . . . .	17
3.5 Neg <sub>2</sub> . . . . .	18
3.6 Extensions. . . . .	18
4. Tone . . . . .	19
5. Tense, aspect, tone, and Makua syntax. . . . .	23
Notes. . . . .	26
CHAPTER III: THE NOTION "BASIC WORD ORDER" AND ITS DEFINITION WITHIN A PHRASE STRUCTURE GRAMMAR . . . . .	28
1. Introduction . . . . .	28
2. Basic formalism of the phrase structure grammar. . . . .	29
2.1 The phrase structure grammar. . . . .	30
3. Defining a basic syntactic order within the present framework. . . . .	36

3.1	Metarules . . . . .	38
3.2	Metarules and basic order . . . . .	41
3.3	Derived categories and derived rules. . . . .	42
4.	Six common criteria used to establish a basic order. . . . .	48
4.1	Introduction. . . . .	48
4.2	Word order and clause types . . . . .	50
4.3	Marked versus unmarked order. . . . .	57
4.4	Ambiguity and preferred readings. . . . .	63
4.5	Frequency . . . . .	68
4.6	Typological criteria. . . . .	68
4.7	Comparative evidence. . . . .	78
5.	Summary. . . . .	79
	Notes. . . . .	82
CHAPTER IV: A FRAGMENT OF THE SYNTAX OF MAKUA MAIN AND COMPLEMENT CLAUSE TYPES. . . . .		85
1.	Introduction . . . . .	85
2.	Empirical predictions made by the use of derived rules and metarules. . . . .	88
2.1	Unbounded dependencies - derived rules versus metarules. . . . .	88
2.2	Resumptive pronouns, traces, etc. . . . .	93
2.3	Summary . . . . .	94
3.	The analysis of word order in Makua. . . . .	94
3.1	The basic rules . . . . .	95
3.2	Unbounded dependencies. . . . .	112
3.3	Metarules . . . . .	121
4.	Conclusions. . . . .	136
5.	Implications . . . . .	138

Notes. . . . .	.145
CHAPTER V: VERB AGREEMENT. . . . .	.149
1. Introduction . . . . .	.149
2. The facts and the feature schemata . . . . .	.150
2.1 The facts . . . . .	.150
2.2 The analysis - Verb agreement and the basic rules . . . . .	.156
3. Metarules and verb agreement . . . . .	.161
4. Derived rules, linking rules, and agreement schemata . . . . .	.170
5. Conclusions and implications . . . . .	.178
Notes. . . . .	.180
CHAPTER VI: RELATIVE CLAUSES . . . . .	.181
1. Introduction . . . . .	.181
2. Relative clause facts. . . . .	.182
3. The distribution of demonstratives in NPs and in relative clauses. . . . .	.187
4. Verb agreement in relative clauses . . . . .	.191
5. Verb agreement suffix in relative clauses. . . . .	.197
6. Conclusion . . . . .	.201
Notes. . . . .	.203
CHAPTER VII: CONCLUSION. . . . .	.207
1. Introduction . . . . .	.207
2. Free word order languages. . . . .	.207
3. Basic syntactic order. . . . .	.210
4. Makua and the framework. . . . .	.211
5. End. . . . .	.212
Appendix A. . . . .	.213

Appendix B . . . . . 217  
Vita . . . . . 222  
References . . . . . 225

## TABLE OF ABBREVIATIONS

1. ag. - agreement morpheme (e.g. adjectival agreement)
2. app. - applied (verbal) extension
3. caus. - causative (verbal) extension
4. dem - demonstrative affix
5. HFC - Head Feature Convention
6. neg<sub>1</sub> - negative morpheme (sentential)
7. neg<sub>2</sub> - negative morpheme (lexical)
8. pass. - passive (verbal) extension
9. PSG - Phrase Structure Grammar
10. oa - object agreement prefix
11. sa - subject agreement prefix
12. t or t/a - tense, aspect, mood affixes
13. TG - Transformational Grammar

## CHAPTER I

## INTRODUCTION

This thesis is an examination of the syntax of a largely undescribed Bantu language, Makua.<sup>1</sup> Such a study is motivated not just by the intrinsic value that derives from an in-depth exploration of any (but especially a little known) language, but also by a syntactic property that Makua exhibits that is of considerable general interest. This language has a high degree of word order freedom, but, unlike many other languages with this property, the nouns display no case marking.

The principle aim of this thesis is to provide a fragment of the grammar for Makua consisting of a precisely defined syntax (and to a much lesser extent, a semantics) for what is intended to be a significantly large body of data. The framework in which this fragment is defined is one which embodies, formally, two trends in linguistic theory: 1) a move towards a base-generated syntax and away from transformations, and 2) attempts to define a semantics directly on the syntax of natural language in such a way that the meaning of the whole is a function of the meaning of its parts. The particulars of the framework have been developed by Gerald Gazdar (e.g. to appear a, b) and in joint work by Gazdar, Ewan Klein, Geoffrey Pullum, and Ivan Sag.<sup>2</sup>

The thesis is intended to serve a number of purposes. One is to provide an analysis of Makua word order. I show that word order in Makua is not entirely free, being subject to certain syntactic constraints, so that it is possible to separate out syntactic rules with specific effects. Thus, I will claim that word order in Makua is not "scrambled", but definable by

a set of rules. This multi-rule approach is in opposition to proposals for free order languages in other theoretical paradigms (e.g. Ross's (1967) scrambling transformation for Latin, Hale's (1979) treatment of W\* languages and Lapointe's (1980) Unspecified Category rules). In the analysis proposed in this thesis, Makua is claimed not to differ in any fundamental way from a fixed order language.

A second purpose of the thesis is to investigate the formal devices of the framework in question. One question that arises with respect to any novel formal model is how well (or badly) that formalism stands up in the analysis of radically different language types. The evaluation of the formalism addresses two separate but related issues. First, there is the question regarding the adequacy of any base-generated syntax for the analysis of natural language. The syntactic rules in the present framework are all phrase structure rules. There are no transformations. Because generative grammars employing only phrase structure rules have standardly been argued to be not only inelegant and incapable of capturing linguistic generalizations but empirically inadequate for the description of natural language as well, it is an interesting enterprise to see whether the present framework can provide even an observationally adequate (in the sense of Chomsky (1965)) characterization of Makua. The second point of evaluation revolves around the formalism specific to this version of phrase structure grammar, that is, whether or not the formalism allows for an adequate characterization of Makua syntax and, more particularly, whether any of the formal devices seem to provide an explanation for the facts.<sup>3</sup>

The analysis shows that not only does the framework allow for observational adequacy but it provides for elegant and general statements as well. In addition, certain formal devices are shown to be capable of explaining

some unruly facts about Makua morphology. Thus, the analysis stands as an implicit argument in favor of the approach adopted. I would like to stress, however, that this thesis does not stand as an explicit argument against any competing account, transformational or otherwise.

The two sorts of evaluation mentioned above are the major theoretical concerns which motivate the thesis. Since theories have a way of becoming rapidly outdated, a more lasting contribution may well be the presentation of data on an uninvestigated language and one which has the interesting property of considerable word order freedom. I hope that the theoretical commentary does not detract from the presentation of the data but, rather, that it enhances the discussion. Such formal precision forces one, at the very least, to ask questions about the language one might otherwise neglect. In the best case, an analysis of explanatory value may emerge. These advantages, when weighed against the possible inadequacies of any theory have prompted me to adopt this less descriptive approach.

Before summarizing the outline of the thesis, several introductory remarks about the language and mode of research are in order. The Makua language is spoken by over two million people, approximately 200,000 of these residing in Tanzania and the vast majority dwelling in Mozambique. There is no systematic analysis of Makua dialectology available, and in any case the situation is likely a quite complicated one due to the fact that the Makua appear to have migrated into Tanzania in small groups which derived from various dialect groups in Mozambique. In any case, the present thesis is based exclusively on data from a dialect that identifies itself by the term *Imit<sup>h</sup>upi*, which is spoken in Masasi district in southern Tanzania.



There is very little modern linguistic work on Makua available; the principle works in recent years have been written in Portuguese and deal with the dialects in Mozambique. Although these works have been unavailable to me, they appear to be general introductions to the language and are unlikely to include a detailed analysis of the syntax. The older literature on Makua derives from the work of missionaries in the early part of this century and primarily concerns the morphology (as is true of most traditional works on Bantu languages). Thus the present study represents to my knowledge the first modern treatment of Makua syntax.

The investigation of this particular dialect of Makua is part of a body of research conducted by students and faculty of the University of Illinois on Bantu languages over the past ten years. More recently, research initiated by Professor Charles W. Kisseberth has spawned particular interest in a number of Tanzanian languages. To date, we have investigated two dialects of Makua: Ikorovere and Imit<sup>h</sup>upi (Ikorovere is spoken in Tunduru district, which neighbors Masasi, where Imit<sup>h</sup>upi is spoken). The work on Imit<sup>h</sup>upi is based on data provided by John Wembah Rashid, a graduate student in Anthropology at the University of Illinois, during some thousand contact hours over a two year period. The data on morphology, phonology and tone were collected in conjunction with Professors Kisseberth and Chin Chuan Cheng. The syntactic investigation I conducted myself. Hopefully, as the research continues, it will be possible to verify these data with more native speakers in Tanzania. As it stands, the data here cannot be generalized beyond Imit<sup>h</sup>upi (although Ikorovere appears not to differ in any major way syntactically). As such, this analysis is just the first step in providing what we hope will be a full-fledged grammar and dictionary

of the two Tanzanian dialects.

In broad outline, the thesis is organized as follows. Chapter II provides a description (in non-technical terms) of that Makua structure needed in order to follow the ensuing discussion. Full tables of morphology are presented in Appendix A for interested Bantuists. In the third chapter I present a discussion of the general notion of basic word order in connection with a definition of basic syntactic word order as defined in the framework under discussion. It is shown how a single basic word order could be defined within the framework being explored and what sorts of evidence would count in choosing one order over another. The relationship of this definition of syntactic basic order to other related notions of basic word order (e.g. marked vs. unmarked, typological) is taken up. It is argued that these ancilliary definitions of basic word order are not necessarily motivated by the same sorts of evidence that count for establishing a basic syntactic order. Rather, it seems that the linguist's intuition that there is a single basic order is based on a variety of factors which may impinge on the syntax but which need not be, strictly speaking, syntactic.

The following three chapters constitute the analysis of the grammar fragment of Makua. Chapter IV provides the analysis of word order proper. Various rules are proposed, motivated in part by their application to separate categories and in part by their properties with respect to bounded versus unbounded dependencies (a distinction made explicit in the formalism). The fifth chapter extends the analysis of word order to include verb agreement. In addition to accounting for the facts, the specific formulation provides support for various classes of rules and for specific claims about

constituent structure, notably the existence of a syntactic VP in some orders but not in others. The sixth chapter on relative clauses is a venture into a single construction. As such it allows for a detailed description of one of the more complex constructions in the language. At the same time, the analysis of relative clauses supports (to a certain extent) the analysis of word order and makes use of some of the finer points of the framework. A concluding chapter summarizes the findings and states the implications of this work for more general linguistic considerations.

## NOTES

<sup>1</sup>This research was made possible by grants from the University of Illinois Research Board, a University of Illinois Dissertation Grant (1978) and University of Illinois Graduate Fellowships (1978-80).

<sup>2</sup>The relevant references are: Gazdar (to appear a, to appear b) Gazdar, Pullum, and Sag (1980), Maling and Zaenen (to appear), Gazdar and Sag (to appear).

<sup>3</sup>In order to be fair to the present framework, I would like to point out several motivations which prompted Gazdar to explore this approach. The reader is referred to Gazdar (to appear b) in particular, for more thorough discussion. The lack of treatment of the issues he addresses is not meant to imply that they are not important. They are. Rather, a full treatment is beyond the scope of the thesis. Here then, is a brief summary of the motivation for such an enterprise.

Much of the work within the transformational paradigm has been toward the constraining of the transformational component. The constraints on the transformational component range from Ross's (1967) seminal work in which he proposed constraints on a certain class of rules to Chomsky's limitation of the transformational component to a single transformation (1979)). The present framework is part of a more radical approach, the exploration of a theory which espouses no transformations at all. Although, at first glance, this latter approach might appear to be throwing out the baby with the bath water, it remains to be seen whether this is so.

The reasons one might investigate this latter more radical approach in general, and this specific framework in particular, are the following. First, this framework (but not current transformational models) has well-understood mathematical properties. The grammar is a context-free phrase structure grammar. Another of the motivations for the exploration of this particular version of phrase structure grammar is that Gazdar makes use of formal devices not previously explored in syntactic theory. These devices, however, are completely within the mathematical confines explicated above. The first such device is the use of a set of derived categories and a rule schema which together account for unbounded dependencies. The second is the use of inductive rule schemata which allow for generalizations to be stated over sets of rules. Each of these formal devices is explicated in detail where needed. What is of importance here is that part of the motivation for this approach is that unless the full power of such phrase structure grammars is explored, any arguments that such grammars are inadequate for natural language do not go through.

A third motivation underlying this particular formal approach is a growing interest in defining a semantic interpretation directly on the syntax of a natural language. Rather than relying on a semantic interpretation of

the output of a syntactic component, the semantics are interpreted on the syntax directly. For each syntactic rule there is a corresponding semantic rule. This approach falls under the rubric of Bach's rule-by-rule hypothesis (1976).

Taken together, the precise mathematical properties of the system, the addition of unexplored formal devices, and the addition of a rigorous semantics make this enterprise a plausible one, whether or not ultimately a correct approach to the grammars of natural languages.

## CHAPTER II

## BASIC MAKUA

## 1. Introduction

This chapter has two purposes. One is to provide a descriptive account of the basic Makua morphology which will be helpful to the reader in subsequent discussion.<sup>1</sup> The second is to provide new data for Bantuists, since little is known about the Makua dialects and virtually nothing is known about Imit<sup>h</sup>upi itself. To this end, Appendix A provides more complete data in the form of tables for Imit<sup>h</sup>upi morphology than is provided in the text of this chapter.

The chapter is organized as follows. Section 2 introduces mainly the structure of Makua nouns and, to a lesser extent, the structure of noun phrases. The third section includes a discussion of the Imit<sup>h</sup>upi verb. Verbal morphology is quite complex, embracing not only inflectional morphology (including subject and object agreement affixes and tense and aspect affixes) but derivational morphology as well (including morphemes marking verbs as causative, passive, applied, etc.). In Section 4, I discuss the tonal structure in broad outline. Section 5 presents data concerning an interaction between tense and aspect and the syntax of Imit<sup>h</sup>upi. While this interaction is crucial in giving a complete picture of the syntax of this language, it is one area of the grammar which does not figure into the larger analysis proposed. That is why it is included here.

## 2. Nouns

It is probably as important to state what Makua nouns do not have in the

way of morphology as it is to describe what they do have. Nouns in Makua (and in Bantu in general) are not case-marked, a fact which is perhaps surprising given the degree of word order freedom in the language. There are no articles as such, although the demonstratives have not only a function marking distance from the speaker and hearer but also a function related to the definiteness with respect to discourse. That is, depending on the position of a noun in the sentence, a demonstrative can be used as just that, or it can signal to the audience that that noun has been mentioned before. (See Section 3.6 in Chapter III for a discussion of demonstratives with respect to word order and Sections 2 and 3 of Chapter VI for a presentation of noun phrase syntax).

What is of importance for the analysis to follow is a basic understanding of the noun classes since they trigger agreement of various sorts, notably subject and object agreement. Makua nouns, like nouns in all other Bantu languages and many other Niger-Congo languages as well, are divided into noun classes. A noun class is a set of nouns which (a) share a characteristic prefix and (b) govern the appearance of particular agreement morphemes on items such as verbs, adjectives, demonstratives, etc. These noun classes have, in traditional grammatical treatments, been given numbers according to their counterparts in Proto-Bantu reconstructions. I will follow that tradition here. Of the twenty-three noun classes reconstructed so far, Imit<sup>h</sup>upi has fifteen.<sup>2</sup> It is not uncommon for Bantu languages to have reduced the number of distinct noun classes, either as a result of phonological mergers or morphological reanalysis. Perhaps it is worth noting that the most surprising gap in the noun class system is the absence of Classes 7 and 8 which (to my knowledge) are hardly ever lacking, at least in

eastern Bantu; there is evidence that the absence of this pairing is due to a falling together of Classes 7 and 8 with Classes 9 and 10.

Some of these prefixes function as pairs, one marking the singular and one the plural, so that a noun with prefix ni- (Class 5) always has as its corresponding plural the same stem with the prefix ma- (Class 6). Examples of this pairing are in (1). See Section 4 of this chapter for discussion of tone orthographical conventions used in this thesis.

- |    |    |           |                   |
|----|----|-----------|-------------------|
| 1. | a. | ni-váká   | 'spear'           |
|    |    | ma-váká   | 'spears'          |
|    | b. | ni-kíráci | '(a kind of) yam' |
|    |    | ma-kíráci | 'yams'            |

One noun class (2a) has no overt prefix in the singular but does have one (a- Class 2) in the plural. Thus one finds pairs of the following sort:

- |    |    |                 |                          |
|----|----|-----------------|--------------------------|
| 2. | a. | hénéne          | 'frog'                   |
|    |    | á-hénéne        | 'frogs'                  |
|    | b. | nańlúkunakoma   | '(a kind of) thorn tree' |
|    |    | á-nańlúkunakoma | 'thorn trees'            |

Another pair of prefixes is not really distinct (Classes 9 and 10), since both exhibit the prefix i-, but they do govern different agreements. Thus, the following nouns have demonstrative suffixes which differ in agreement according to whether the noun is singular or plural.

- |    |    |              |                            |
|----|----|--------------|----------------------------|
| 3. | a. | ikáláva      | 'canoe, canoes'            |
|    | b. | ikálávélá    | 'this canoe' (ikalava+ila) |
|    | c. | ikáláva-cílá | 'these canoes'             |

Still other prefixes do not fall into singular-plural pairs, notably the locative prefixes, mu- 'in', va- 'on', and u- 'at' (Classes 15-17). Additional features distinguish these locative prefixes from the others.



In Imit<sup>h</sup>upi, locative nouns generally have, in addition to a regular noun class prefix, a suffix -ni (a feature which is particularly common in eastern Bantu languages). More often than not, locative prefixes behave as pre-prefixes, prefixed to a noun which already has a noun class prefix. These pre-prefixes do, however, trigger the full range of possible agreements so that they share syntactic properties with the other noun class prefixes.<sup>3</sup> In (4) below is the noun for 'desk' ndawaati (a class 5 noun in which the prefix ni- has undergone the loss of a vowel according to regular phonological processes in the language).

- |       |                 |               |
|-------|-----------------|---------------|
| 4. a. | ndawaáati       | 'desk'        |
| b.    | mu-ndáwaáati-ni | 'in the desk' |
| c.    | va-ndáwaáati-ni | 'on the desk' |
| d.    | u-ndáwaáati-ni  | 'at the desk' |

A question often posed is whether the noun class of a noun can be predicted on semantic grounds, i.e. whether the noun class prefixes need to be entered in the lexicon along with their nouns or whether some rule can account for the prefix. The answer is a qualified no. Synchronically, one can find in Makua (as in many Bantu languages) a sort of generalization; most human and animate nouns fall into Classes 1a, 1 and 2, but not all. In addition non-animate nouns are found in these classes as well. It is even less profitable to look for semantic generalizations in the other classes, although there are regular word formation processes involving some of the prefixes (e.g. the locatives, the infinitive prefix, and the augmentatives and diminutives). Outside of these regular formation processes, however, Makua nouns will have to be entered in the lexicon with prefixes intact. Additional evidence to support this position comes from the behavior of tone

which needs to be lexically marked. See the examples and attendant discussion in (16) in this chapter showing how the prefixes are treated as part of the lexical items.

In addition to the interaction of noun classes and agreement, a second relevant issue with respect to the data discussed in the body of the thesis is the order of words in the noun phrase. The most important fact is that the order of a noun and its modifiers is fixed. Adjectives, genitives, and relative clauses all follow their head nouns. These modifiers cannot be separated from their nouns (there seems to be nothing like Relative Clause Extraposition as in English where a heavy relative clause is separated from its head noun and is found at the end of the clause). Furthermore, noun phrases cannot be extracted out of (i.e. they are islands) by topicalization or relativization. Demonstratives have a somewhat complicated distribution and are discussed in Chapter VI where the syntax of noun phrases is taken up in some detail. The examples in (5) and (6) are illustrative of the internal order of noun phrases as well as the agreement that the head noun governs. (The prefix appearing on the name Sepété is one of three prefixes, hín, ché and á, used as honorifics).

5. a. ni-váká ni-kíná  
pref-spear ag-other  
'another spear'
- b. nné-ni-váká ni-kíná-nné  
'those (over by you) other spears'
- c. nné- ni- váká n-a Hín- Sepété - nné  
dem-pref-spear ag-gen Sepete - dem  
'that spear of Sepete'
- d. ni - váká naa - hán - íle Hín- Sepété - nné ...  
pref-spear ag/t/a-forge-t/a Sepete - dem  
'the spear that Sepete forged...'

6. a. i - hípá i-kíná  
 pref-hoe ag-other  
 'another hoe'
- b. ílé - hípá ikín-élé  
 dem-hoe other/dem  
 'that (over by you) other spear'
- c. ílé - hípá y- a Hín - Sepétélé  
 dem hoe ag-gen Sepete/dem  
 'that hoe of Sepete'
- d. ihípá y- aa - hán - íle Hín - Sepétélé...  
 hoe ag-t/a-forge - t/a Sepete/dem  
 'the hoe that Sepete forged...'

Thus, two facts about Imit<sup>h</sup>upi nouns are relevant for the analysis to be presented. One is that the nouns are marked by prefixes and govern agreement. (An analysis of verb agreement is taken up in Chapter V). The second is the internal structure of the noun phrase itself. The word order of a noun phrase is fixed, and no morpheme belonging to this constituent can appear elsewhere in the sentence. The syntax of the noun phrase is also relevant to the analysis of relative clauses and is taken up in Chapter VI.

### 3. Verbs

As is the case with most, if not all Bantu languages, Imit<sup>h</sup>upi has a complicated verb morphology. In (7) below is a frame showing the order in which various morphemes appear. The parentheses indicate optional morphemes. Each of the kinds of morphemes is then taken up and discussed separately.

7. (neg<sub>1</sub>) - sa - t - oa - (neg<sub>2</sub>) - stem - (extensions) - t

neg<sub>1</sub> - sentential negator (k<sup>h</sup>a-)  
 sa - subject agreement prefix  
 t - tense, aspect, and mood affixes  
 oa - object agreement (including the reflexive -i-)  
 neg<sub>2</sub> - verbal negation (-hi-)  
 extensions - (one or more of the following)

causative	<u>-ih-</u>	
applied	<u>-el-</u>	(~ <u>-er-</u> )
passive	<u>-iy-</u>	
stative	<u>-e-</u>	
iterative	<u>-es-</u>	
reciprocal	<u>-an-</u>	

Vowel coalescence can occur between all of these morphemes. When this happens, the two morphemes and their glosses are not separated by a hyphen in the transcription used here. Rather, a slash is used (i.e. sa/t instead of sa-t).

3.1 Neg<sub>1</sub>

The negative marker k<sup>h</sup>a- (which may alternatively show up as just a- in the first person singular) is prefixed to the verb. It generally indicates sentential negation, although it can interact with focus tone and word order to yield a reading more like that of constituent negation. Compare the examples in (8) below. In (8a) the subject NP is preceding the verb and the reading is straightforward sentential negation. In (8b) the tone is altered on the subject NP and it follows the verb. The reading in the second case is one of constituent negation, i.e. the verb itself is not negated. This morpheme, k<sup>h</sup>a- can be prefixed to verbs marked by only a restricted subset of t morphemes. See Section 5 of this chapter where this fact is discussed in more detail.

8. a. báásikely - úlé k<sup>h''</sup>áá - wulúw - íle  
 bicycle -dem neg<sub>1</sub>/sa/t -fall- t  
 'the bicycle didn't fall'
- b. k<sup>h''</sup>áá - wulúw - íle baasikely - úlé  
 'It isn't that bicycle that fell (something else did)'

While the interaction of this sort of negation with word order (in particular its interaction with quantified nouns) is of crucial importance for a full-fledged treatment of the syntax and semantics of Makua, I have not incorporated this into the analysis.

### 3.2 SA.

With just two exceptions (one is in relative clauses as discussed in Chapter VI and the other is in topicalized sentences as discussed in Chapter V) the SA prefix is in agreement with the noun class of the subject of the clause. Subject agreement is obligatory (although there are a couple of instances in which there is no overt morpheme, i.e. Class 1 and 1a nouns and third person uninitiated sg.) so that even if no overt NP shows up some agreement marker does. When the overt NP is missing these prefixes take on an essentially anaphoric function, although they can be used to make reference to an indefinite subject as well. Compare the examples in (9) below. (9a) has an overt subject NP (third person sg. initiated) while (9b) does not. (9b) has two readings, which are separated out by context. One is anaphoric, the second is indefinite.

9. a. Hín - Sepété a - nóó - rwa - a  
 Sepete sa- t leave - t  
 'Sepete is going to leave'
- b. A - nóó - rwa - a  
 1. 'he left'  
 2. 'someone left'

Nearly all of the examples which appear in the analysis are, however, with

overt NPs because their appearance is crucial in establishing the word order.

### 3.3 T/A

See Appendix A for a partial list of T/A morphology and Section 5 of this chapter for some discussion of the interaction of T/A morphemes with the syntax of *Imit<sup>h</sup>upi*.

### 3.4 OA.

Like subject agreement, object agreement occurs both when the object noun is overt and when it is not. Unlike some Bantu languages, in which the object prefix cannot cooccur with an overt noun (e.g. Shona), and others in which agreement is syntactically optional (e.g. Swahili where agreement is more likely to occur with human nouns) object agreement in *Imit<sup>h</sup>upi* is obligatory when an object noun occurs. There is, however, an important gap in the morphology. There are no object agreement morphemes for classes other than 1a, 1, 2 and the personal pronouns. This gap creates some complicated agreement patterns with respect to the objects of bi-transitive verbs. These facts are taken up in Chapter V. For the time being, it will suffice to illustrate the nature of agreement with simple transitive verbs. In (10a) below the object of the verb is overt and it is of Class 1a, which triggers the appearance of the prefix -mu- (which shows up as just a nasal consonant preceding most consonants). In (10b) no overt object appears and the sentence has two readings: one anaphoric, the other indefinite, parallel to the subject agreement example in (8b) above. (10c) shows a verb with a Class 5 noun. In this case there is simply no agreement form available. No morphological trace of it is present.

10. a. Hín - Sepété áhó - n̄ - th<sup>h</sup>úm-a báásikeli  
 Sepete sa/t -oa - buy -t bicycle  
 'Sepete bought a bicycle'
- b. Hín - Sepété áhó - n̄ - th<sup>h</sup>úm - a  
 Sepete sa/t -oa - buy - t  
 1) 'Sepete bought it'  
 2) 'Sepete bought something'
- c. Hín - Sepété áhó - th<sup>h</sup>úm - á niváká  
 Sepete sa/t - buy - t spear  
 'Sepete bought a spear'

### 3.5 Neg<sub>2</sub>

The negative prefix -hi- is a verbal negator. No tense and aspect restrictions of the sort associated with Neg<sub>1</sub> are in effect. It may co-occur with Neg<sub>1</sub> as the following examples show.

11. a. Hín - Sepété áhó - hí - píc - a  
 Sepete sa/t -neg<sub>2</sub>- delay-t  
 'Sepete did not delay'
- b. Hín - Sepété k<sup>h</sup>áá - hi - píc - íle  
 Sepete neg<sub>1</sub>/sa/t-neg<sub>2</sub>-delay-t  
 'Sepete didn't delay'

### 3.6 Extensions

Of the extensions given in the list in (7) above, only two, the causative and the applied, figure into the analysis. These two suffixes are important in the syntax because they have the semantic effect of increasing the valence of the verb by one, so that intransitive verbs have an additional noun argument and transitive verbs become bitransitive, having an additional noun argument as well. Because these extensions are discussed in Chapter IV, they are not discussed here.

## 4. Tone

The purpose of this section is to outline in broad terms how tone in Imit<sup>h</sup>upi works so that the transcription (which is not phonetic) is not misleading. Imit<sup>h</sup>upi tone can be analyzed in terms of two tones, Hi and Lo. In the orthography used in the thesis, Hi tones are marked by an acute accent; Lo tone is left unmarked.

The most striking property of Imit<sup>h</sup>upi tone is that Hi tones come in pairs. The second of a pair of Hi tones, under two circumstances is not heard, however. First, if the second of a pair of Hi tones is utterance final it is pronounced phonetically low. Thus, the word for 'hoe' in (12) below is pronounced in isolation as in (10a), but it is transcribed as in (12b). That the second of the pair is present (in some sense) is evidenced by the addition of the demonstrative suffix. The second Hi tone then emerges (although the second of the pair of Hi tones on the demonstrative is pronounced low). Thus, the pronunciation of 'this hoe' is as in (12c) but written as in (12d).

- |        |            |               |
|--------|------------|---------------|
| 12. a. | ihípa      | 'hoes'        |
| b.     | ihípá      | 'hoes'        |
| c.     | ihípá-cíla | 'these hoese' |
| d.     | ihípá-cílá | 'these hoese' |

The second of a pair of Hi tones may also be phonetically realized as a long fall just in case the pair of Hi tones occurs on a long penultimate syllable in utterance final position. Apparently, long vowels constitute two mora which count as two tone-bearing units. Thus, a Hi tone on the first mora of a long vowel has its paired Hi on the second mora, which is then lowered in utterance final position. For example, the word for 'incense' will be heard



in isolation as (13a) but written as (13b). Again, if a suffix is added to the noun, the second Hi tone emerges as part of the level Hi tone. (13c) represents the broad phonetic transcription, (13d) the orthography.

13. a. ru<sup>h</sup>báani 'incense'  
 b. ru<sup>h</sup>bááni 'incense'  
 c. ru<sup>h</sup>bááníla 'this incense'  
 d. ru<sup>h</sup>báánílá 'this incense'

If the first of the pair of Hi tones is utterance final, however, it is pronounced as a Hi tone as indicated by the example in (14) below. It should be noted however, that the appearance of a final Hi tone is extremely rare. In fact, this construction is the only one I am aware of to date, in which this occurs.

14. báásikeli k<sup>h</sup>a - wuluw - ilé  
 bicycle neg<sub>1</sub>/sa-fall - t  
 '(the) bicycle hasn't fallen down'

The transcription in the thesis does not reflect either the utterance final lowering or the long fall.

The utterance final lowering, I originally thought, might be of use in the analysis of word order since it seemed plausible that lowering might occur between constituent boundaries in some orders but not in others, i.e. I thought it might be a clue to distinguishing basic from non-basic orders, since it could have been the case that the correct characterization was constituent final rather than utterance final lowering. This lowering turned out not to be relevant.<sup>4</sup> I did discover, however, that such lowering did take place, apparently obligatorily, at the end of a relative clause, and on the last word before a complement clause when the complementizer is not present. Thus,

utterance final lowering is not quite an accurate term.

In addition to these phenomena, two other phonetic details are missing in the transcription here. One is that the first Hi tone of an utterance will in certain (though not all) contexts be heard as either low or mid. Thus compare the examples in (15a-d). In the first example, (15a), the first Hi tone of a pair in a word is often heard as low or mid. But the word is transcribed as in (15b) which does not reflect these phonetic details. When the first of a pair of the Hi tones follows a Hi tone immediately, however, it is regularly heard as a Hi tone. Thus, the example in (15c) is pronounced as indicated and transcribed as (15d). The other missing phonetic detail is that the second Hi tone of a pair will be heard with a slight fall on the penultimate syllable. Thus for the word for 'rabbit' in (15e-f) the phonetics are as in (15e) but the transcription will be as in (15f).

- |        |                            |                     |
|--------|----------------------------|---------------------|
| 15. a. | á'léto                     | 'strangers'         |
| b.     | á'léto                     | 'strangers'         |
| c.     | á'hóth <sup>h</sup> ú'míha | 'he sold something' |
| d.     | á'hóth <sup>h</sup> ú'míha | 'he sold something' |
| e.     | húkúla                     | 'rabbit'            |
| f.     | húkúla                     | 'rabbit'            |

As mentioned above, the transcription used here includes vowel coalescence. However, the analysis of tone (see Cheng and Kisseberth (1979) and (1980) for details) works best if tone is assigned and tone rules apply. When vowels coalesce, the ruling principle is that Hi tones are preserved. The example in (16a) below represents the underlying form of the verb, that in (16b) my transcription.

16. a. a - ho - á - épét<sup>h</sup>á  
 sa- t - oa - thresh-t  
 'he has threshed it/something'
- b. a - héépét<sup>h</sup>-á  
 sa-t-oa-thresh-t  
 'same'

It turns out that tone must be lexically marked on Imit<sup>h</sup>upi nouns (although it can apparently be predicted in large part on the basis of noun class in the closely related dialect of Ikorovere) so that two nouns of the same class may have different tone patterns. This is exemplified by the examples in (17). Both are Class 3 nouns (again the prefix mu- is reduced to a nasal consonant which assimilates in place of articulation to the following consonant).

17. a. n̄ - kácu                    'cashew nut tree'  
 b. n - huk<sup>h</sup>ó                    'bag'

Imit<sup>h</sup>upi verbs, unlike the nouns, have entirely predictable tone patterns. There is no need to mark lexical contrasts on the verb stems themselves. Instead, the t morphemes themselves have a Hi or a Lo tone and have associated with them further tone assignment rules whereby a Hi tone pair is assigned to tone bearing elements in the verb root. The past tense morpheme -aho-, (but not -ho-, the present perfect form), for example, has a pair of Hi tones itself and has associated with it a pattern whereby a Hi tone pair falls on the first and second tone bearing elements of the verb root. Object prefixes count as part of the root for purposes of tone assignment. In addition, for this particular past tense morpheme, a pair of Hi tones appears on the penultimate and ultimate tone bearing elements. (A tone bearing element is either a vowel or a nasal; all nasals which are themselves

morphemes bear tone, but we have been unable to predict which other stem-internal nasals bear tone). In (18) below is a verb with the past tense morpheme -aho-. (18a) does not have an object prefix, while (18b) does, showing that the root includes this object prefix for purposes of tone assignment.<sup>5</sup>

18. a. áhó - wúlúw - íh - á  
 sa/t- fall -caus - t  
 'someone/he caused it/something to fall'
- b. áhó - ñ - wúlúw - íh - á  
 sa/t-*oa* - fall- caus - t  
 'someone/he caused someone/something/it/him to fall'

Other combinations of t morphemes induce other tone patterns, but they are entirely predictable and regular in terms of how these patterns are associated with a given verb stem.

Tone then does not really enter into the discussion of word order in any crucial way. It is included here in the interest of completeness.

##### 5. Tense, aspect, tone, and Makua syntax

The phenomena to be discussed in this section go beyond morphology, strictly speaking, into that murky realm of interaction between the meaning of the tense and aspect morphemes themselves, the syntax, tone, and even pragmatics. The consequences of this interaction for word order are easily described, but I am providing no analysis which accounts for these facts. The solution rests ultimately, I think, on the semantics of the tense and aspect morphemes themselves. A formal treatment of this part of the grammar of Imit<sup>h</sup>upi would go well beyond the scope of the thesis.

Here are the facts. The tense and aspect morphology in Imit<sup>h</sup>upi is split into two sets. One set (Set A) appears on relative clause verbs, verbs in

constituent questions, verbs with the sentential negator  $k^h a-$ , and on the main verb of cleft constructions.<sup>6</sup> In addition, when these morphemes occur in declarative sentences, some constituent (an adverb, NP, adjective, or infinitive phrase) is in focus. (See Stucky(1979a) for a descriptive account of the nature of this focus). This focused constituent must be postverbal, generally immediately following the verb. In addition, if this focused constituent is a noun, its basic tone pattern may be altered in such a way that the first pair of Hi tones is not pronounced. (See Stucky(1979b) for an analysis of these facts.) The upshot of this is that verb final affirmative, declarative main and subordinate clauses are disallowed when Set A morphemes are employed. One finds the following sorts of judgments.

19. a.  $\acute{m}m\acute{r}aw\acute{o}l\acute{e}$  aa - han-  $\acute{i}l\acute{e}$  nivaka  
 boy/dem sa/t-forge- t spear  
 'It's a spear (not a hoe or something else) that the boy forged'
- b.  $niv\acute{a}k\acute{a}$  -  $\acute{r}n\acute{e}$  aa - han -  $\acute{i}l\acute{e}$   $m\acute{m}r\acute{a}w\acute{o}l\acute{e}$   
 'It's the boy (not the girl or something else) that forged the spear'
- c. \* $niv\acute{a}k\acute{a}r\acute{n}\acute{e}$   $\acute{m}m\acute{r}aw\acute{o}l\acute{e}$  aa-han- $\acute{i}l\acute{e}$

The restriction on word order to the effect that the verb cannot be final is not found in any of the other constructions in which the tense and aspect morphemes participate (relative clauses, sentential negation, etc.).

The fact that (19c) is incomplete is, I suspect, not entirely a syntactic fact, but one which is due, rather, to some interaction between focus post-verbal position and the meaning of the T/A morphemes themselves. Since that is my suspicion, nothing in the analysis of word order (which is essentially syntactic) to be presented accounts for the restriction on order in examples like that in (19c).

Just as the T/A morphemes in Set A appear only in constructions listed

above, Set B cannot occur in those constructions at all. Rather, they show up in declarative sentences without the sort of contrastive focus noted in (19) above and in Yes/No questions (and echo questions). Thus, (19c) with another set of T/A morphemes is not incomplete as evidenced by the example in (20).

20. niváká - ríné ímírāw -ólé aa - han - ílé  
 spear - dem boy -dem sa/t-forge-t  
 'the/that spear, (as expected) the boy forged'

The interaction of focus with tense and aspect is not particularly unique to Makua. Other Bantu languages have special morphology which appears in certain tense and aspect combinations just where Makua has restrictions on word order. Makua, however, lacks such extra morphology. The details differ slightly from language to language, but this phenomena is attested in Zulu, Kinyarwanda, and ChiBemba (See Givon (1975) for details). Watters (1979) has noted a similar sort of interaction between tense, aspect, and focus in a Grassfield's Bantu language, Aghem. Hyman (personal communication) has also described this phenomenon for other Grassfield's Bantu languages. While this interaction is thus not particularly surprising, it has as yet, not succumbed to any formal treatment as far as I know.

This concludes the introduction to basic Makua. Much more could and should be said about the morphology of this language but it is hoped that the little presented here will be helpful and not too confusing.

## NOTES

<sup>1</sup>The morphology of Imith<sup>h</sup>upi differs in some ways from that of the other Makua dialects, so that the facts presented here are not necessarily those of the other dialects.

<sup>2</sup>The noun classes found in Makua are as follows:

Class 1	mu-	(alternating with a nasal consonant which assimilates to a following consonant preceding consonant initial stems)
"	1a ø-	
"	2 a-	
"	3 mu-	(alternating with a nasal consonant)
"	4 mi-	
"	5 ni-	(alternating with a nasal consonant)
"	6 ma-	
"	9 i-	
"	10 i-	
"	11 u-	
	or 14 u-	
"	15 u-	(infinitive prefix)
"	16 mu-	(alternating with a nasal consonant)
"	17 va-	
"	18 u-	
"	23 si-	(diminutive pl.)

<sup>3</sup>The fact that locative prefixes are similar to noun class prefixes in that they may govern agreement, but different by virtue of the fact that they are pre-prefixes, is often reflected in the syntax of Bantu languages. These locative nouns typically pose problems for analyses within the Relational Grammar framework, since they sometimes behave like direct objects and sometimes not. See Trithart (1979) and references there for discussions of various Bantu languages with respect to object relations.

<sup>4</sup>Vowel coalescence, which takes place not only within the word but across word boundaries in Imith<sup>h</sup>upi, behaves in a fashion analogous to tone lowering. Vowels coalesce across all word boundaries regardless of order, except at the end of relative clauses and before a missing complementizer. Kimatumbi, a related Tanzanian Bantu language with word order freedom comparable to that of Imith<sup>h</sup>upi, apparently does use the lack of vowel coalescence to distinguish basic from non-basic orders (Odden (personal communication)).

<sup>5</sup>Imith<sup>h</sup>upi differs from Ikorovere with respect to tone assignment for this T/A morpheme. Where Imith<sup>h</sup>upi has a pair of Hi tones assigned to the first and second tone bearing elements and to the penultimate and ultimate,

Ikorovere assigns a pair to the first and third and to the second and fourth. The details for Ikorovere and Imit<sup>n</sup>upi tone are found in Cheng and Kisseberth (1979, 1980, 1981).

<sup>6</sup>Set B includes the following combinations of T/A morphemes.

- a. -ile (present perfect perfective)
- b. -aa-...-ile (past progressive perfective)
- c. -no- (present progressive)



## CHAPTER III

THE NOTION "BASIC WORD ORDER" AND ITS DEFINITION WITHIN A PHRASE  
STRUCTURE GRAMMAR

## 1. Introduction

There is a common assumption among linguists which claims that if a language displays more than a single order of its major constituents, then one order must be more basic than the others. This assumption, for example, underlies all of the typological universals posited by Greenberg (1972). The same assumption motivated Chomsky (1965:126) to argue against phrase structure rules which define only hierarchical relations as opposed to phrase structure rules which define both hierarchical and linear relations. While this assumption is not entirely uncontroversial (Hale (1979) argues against defining a basic order for Walbiri, an Australian language), I do not wish to question its validity. Rather, I would like to raise two issues regarding the definition of basic order with respect to the version of phrase structure grammar (PSG) entertained in this thesis.

First, is it possible to give a formal definition of basic order within the PSG assumed in the thesis? This question arises not only because the phrase structure rules impose a left to right order, but because separate rules will be required for each order. On the face of it, a simple list of rules hardly allows for any general statement of a basic order. However, it is shown that the rules in this particular version of PSG are not of equal status in the grammar, so that it is, in principle, possible to pick out one order defined by a subset of rules in the grammar as basic. I will refer to this basic order, which is defined by a formally distinguishable

subset of the rules of the grammar, as a syntactic basic order.

The second question to be addressed in this chapter has two parts. Given that it is possible to define a syntactic basic order, then what kind of evidence is relevant in the choosing of one order over another, and, with respect to that evidence, what can we learn about Makua?

In this chapter, six arguments typically used by linguists to establish a basic order for a given language are presented and discussed with respect to the syntactic definition of basic order to be given. In many cases, the putative arguments turn out to be based on assumptions that are unclear. Even when these assumptions are made more perspicuous, the results of the argument are not at all clear when applied to Makua. That is, it is difficult to decide which, if any, of the Makua orders is more basic. Despite the inconclusiveness of the arguments, I think it has been a worthwhile endeavor to sort them out.

The layout of the chapter, then, is as follows. The second section contains a presentation of the basic formal devices to be employed. In the third section, I discuss how alternative orders may be accounted for and give a definition of basic syntactic order within the grammar. Section 4 contains a discussion of potential arguments for choosing a basic order, and these arguments are applied to Makua. The fifth section consists of a summary.

## 2. Basic formalism of the phrase structure grammar.

In order to discuss the notion of a syntactic basic order to be defined in Section 3 of this chapter, it will be necessary to lay out in some detail the formalism employed along with some of the assumptions underlying this formalism. One caveat is in order. This presentation is not meant to be a

complete introduction to the framework. In particular, the mathematical underpinnings of the system are not laid out in great detail. For that, the reader is referred to Gazdar (to appear b) for explication of such issues. Rather, what I hope to present here is a description of the formal apparatus, thus providing a working knowledge of the formalism so that the analysis can be followed not only by those presently working within this particular framework or within similar frameworks, but by those completely unfamiliar with the particulars of this system.

## 2.1 The phrase structure grammar

A rule in this grammar takes the general form in (1) below. It is an ordered triple consisting of a rule number, followed by a phrase structure rule (PS rule), followed by a semantic translation of that rule.

1. <rule number, PS rule, semantic translation>

I think it will be somewhat clearer if I begin with the second member of the rule, the PS rule itself, and then return to a discussion of the rule number and the semantic translation. The word 'rule' is used ambiguously throughout much of the thesis. It is used to refer to the second and third members of the rule together or each separately. Hopefully this will not be confusing for the reader.

The phrase structure grammar which gives rise to the PS rules consists of the usual four items.

First, there is a finite set of terminal symbols ( $V_T$ ) consisting of the lexical items of the language (and, as we will see in Section 3.3, a trace (t) or the empty string (e)). I am assuming, along with Gazdar (to appear b) and others, that lexical forms containing both derivational and inflectional

morphology are given by the lexicon directly rather than derived by some syntactic rule. For example, the Makua derived verb uth<sup>h</sup>umela 'to buy for' which is related to the non-derived verb uth<sup>h</sup>uma 'to buy' will be entered into the syntax directly. Similarly, inflectional features such as verb agreement and tense and aspect morphology are assumed to be lexically intact at the time of lexical insertion.

Secondly, the grammar includes a finite set of nonterminal symbols ( $V_N$ ). Gazdar (to appear b and elsewhere) has assumed these nonterminal symbols to be complex symbols (rather than to be the monadic node labels of early phrase structure grammars in the transformational paradigm). Furthermore, he has assumed a phrasal/lexical distinction along the lines of  $\bar{X}$  syntax (Chomsky (1970) and Jackendoff (1977)). Unlike Jackendoff, I have assumed a two-bar  $\bar{X}$  system rather than a three-bar system. Thus one part of the complex symbol will indicate the phrase level (i.e.  $\bar{\bar{X}}$  and  $\bar{X}$ ) or lexical level (X) of the category. For typographical ease and for reasons of familiarity, I will use the more traditional notation XP (i.e. NP for  $\bar{\bar{N}}$ , Nom for  $\bar{N}$  etc.). In addition to the specification of phrasal lexical level, the complex symbols include a feature bundle which encodes subcategorization facts and morphosyntactic or morphological information. Using a familiar notation for these features, then, there will be such complex symbols as

$$\left[ \begin{array}{l} +N \\ -V \\ +sg \\ +Cl. 9 \end{array} \right]$$
, which designate a lexical category Noun which is singular and

of Class 9.

The third item is the PS rules themselves. These phrase structure rules are to be understood as node admissibility conditions rather than as rewrite

rules (as in more traditional transformational treatments). This difference in interpretation was first discussed by McCawley (1968).<sup>1</sup> Gazdar has used a notation like that in (2a) below rather than the notation of (2b). A rule like that in (2a) will admit a node S when it immediately and exhaustively dominates NP and VP (in that order). That is, it will admit a partial tree like that in (2c).

2. a.  $[_S \text{ NP VP}]$

b.  $S \rightarrow \text{NP VP}$

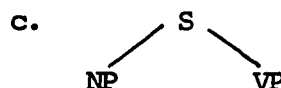

Further (distinct) node admissibility conditions will be needed to admit the NP and VP nodes. If we take the rule in (2a) as one for English, then we will need the rules in (3) below, which admit verb phrase nodes when they dominate a V or a V and a NP.

3. a.  $[_{VP} \text{ V }]$

b.  $[_{VP} \text{ V NP}]$

Putting the rules in (3) together with the rules in (2a), we get partial trees like those in (4a) and (4b). I have filled in some lexical items for the sake of clarity.

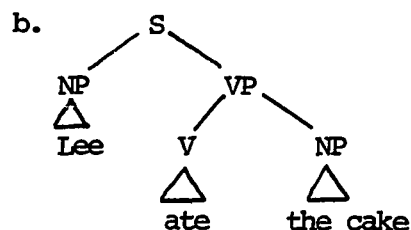
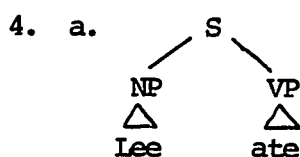

Interpreting phrase structure rules as node admissibility conditions rather than as rewrite rules has important consequences for the class of languages that grammars using such rules can analyze. Peters and Ritchie

(1969, 1973) proved that grammars employing context-sensitive rules under the node admissibility interpretation but not under the rewrite interpretation analyze only context-free languages. Note that this result is important if one is interested in constraining not only the class of grammars but also the class of languages analyzed by the grammar.

The fourth item in the PS grammar is the distinguished symbol  $S$  on which well-formedness is defined. A well-formed sentence is one which is analyzed by the grammar in the following way; the tree is rooted in  $S$ , every node in the tree is admitted by a rule in the grammar, and every leaf is itself a member of the set of terminal categories. More formally, a tree  $T$  is well-formed with respect to a grammar  $G$  if and only if every node in  $T$  is admitted by some phrase structure rule in  $G$  and every leaf of the tree is a terminal symbol of  $G$ . A string  $S$  is well-formed with respect to grammar  $G$  if and only if there is some well-formed tree  $T$  with respect to  $G$  such that  $S$  is identical to that proper analysis of  $T$  which passes through all the leaves of  $T$ . One consequence of the interpretation of the PS rules as node admissibility conditions in conjunction with the definition of well-formed sentence is that there is no derivation, and it follows that it makes no sense to order the rules.

Having defined in broad terms just how the second member of a rule is to be understood, I now return to the first and third members respectively. The first member of the rule is a rule number. It should be evident from the immediately preceding discussion that this number does not imply an order of rules. Rather, the rule numbers are the device by which subcategorization facts are accounted for. Part of the specification of items in the lexicon will be a list of rule numbers accounting for subcategorization. Suppose,

by way of example, that the rules in (3) above are assigned the rule numbers as in (5) below.

5. a. <2, [<sub>VP</sub> V ] ... >  
 b. <3, [<sub>VP</sub> V NP]...>

I will not go into the details of the lexicon here, but the rule numbers in the lexicon together with the rules in the grammar will insure that only intransitive verbs are eventually admitted by rule 2 and transitive verbs by rule 3. Transitive verbs such as eat, which have intransitive counterparts, will be related to these counterparts by a redundancy rule in the lexicon.

The third member of a rule is a semantic translation. The assumption here is that each syntactic rule in the grammar has associated with it a semantic rule, giving the meaning of the constituent created by the syntactic rule as a function of the parts of that syntactic rule. The semantics is at once compositional (in the sense that the meaning of the whole is made up of the meaning of the parts) and conforms to Bach's (1976) rule-by-rule hypothesis (because there is a semantic rule paired with each syntactic rule). Nothing in the form of the syntactic rules forces this choice with respect to semantics. It is an independent choice made by Gazdar but made in the spirit of what has generally come to be known as Montague semantics.

A word about the notational conventions is in order. Gazdar has assumed that the semantics takes the form of an intensional logic (which then receives a model theoretic interpretation). I will ignore issues related to intensionality for the purposes of this thesis and use a prime convention to simply mean 'translation of'. Thus, the semantic notation I am employing is an extremely crude one, but I hope that it will serve to indicate how the syntax

works in tandem with the semantics. By way of example, suppose that the rules in (2a) and (2b) above are completed as in (6).

6. a.  $\langle 1, [{}_S \text{ NP VP}], \text{VP}' (\text{NP}') \rangle$

b.  $\langle 3, [{}_{\text{VP}} \text{ V NP}], \text{V}' (\text{NP}') \rangle$

(6a) says that a VP meaning ( $\text{VP}'$ ) combines with a NP meaning ( $\text{NP}'$ ) to yield a sentence meaning. Rule (6b) says that a NP meaning ( $\text{NP}'$ ) combines with a V meaning ( $\text{V}'$ ) to form a VP meaning ( $\text{VP}'$ ), while meanings themselves are made up of the meanings of their parts.<sup>2</sup> The notation used here provides the rule schemata for constructing translations in intensional logic.

What is important to understand about the semantic translations for purposes of this thesis is that I have assumed that it is the semantics in tandem with the syntax which encodes predicate-argument structure (or grammatical relations). In particular, it is the order in which NP meanings are combined with VP meanings which define grammatical relations such as subject of and object of. The last NP to be combined in the meaning is the subject. The first NP combined in is the direct object. Thus, in the examples in (6) above, the object NP combines with the verb to give a VP meaning and the VP combines with the subject NP last to give a sentence meaning. This obviates the need for an extra level of grammatical relations (i.e. as in Relational Grammar (Postal and Perlmutter (1974)) or as in Bresnan's functional level (c.f. Kaplan and Bresnan (to appear))). Rather, this definition of grammatical relations is more in line with that of Dowty (to appear). He defines grammatical relations in a Montague Grammar framework in a way analogous to the present definition although his is far more explicit.

In the examples in (6) above, there is a syntactic verb phrase as well



as a semantic one. But in the discussion in Chapter IV to follow, there are instances of structures in which there is no syntactic VP (notably VSO orders). In these instances, a semantic VP is retained. (See Gazdar and Sag (to appear) for discussion of such semantic or "phantom" verb phrases in the present framework).

Constituent structure rules, then, are unordered statements. They account for subcategorization facts in a straightforward fashion. The PS rule (i.e. the second member of the complete rule) together with the definition of a well-formed sentence define the set of well-formed sentences of a language. Each sentence is assigned to a labelled tree consisting of the non-terminal symbols and the terminal symbols. Taking this basic rule type, I now turn to the analysis of alternative orders and, in particular, the definition of basic order.

### 3. Defining a basic syntactic order within the present framework

There are two points to be made with respect to phrase structure grammars and word order. One is that linguists have known since the outset of modern TG that a phrase structure grammar might be made to be observationally adequate with respect to order because it is theoretically possible to simply list every possible syntactic order. Thus, imagine a language which has only three nonterminal categories S, A, and B. Then one could write phrase structure rules (under a rewrite interpretation) like those in (7) below.

7.  $S \rightarrow A B$   
 $S \rightarrow B A$   
 $S \rightarrow A S B$   
 $S \rightarrow S A B$   
 $S \rightarrow A B S$   
 $S \rightarrow B A S$   
 $S \rightarrow B S A$   
 $S \rightarrow S B A$

Here is a grammar that generates not only every possible permutation of the categories but one that will generate an infinite set of sentences as well. One could write analogous rules under the node admissibility interpretation as in (8) below that would have the same output as those in (7).

- 8. a. [<sub>S</sub> A B]
- b. [<sub>S</sub> B A]
- c. [<sub>S</sub>A S B]

Aside from the likelihood that such grammars will turn out to be empirically inadequate (indeed, every introductory syntax textbook gives at least one example to argue that this is so),<sup>3</sup> there is another sort of argument that can be levelled against such an approach. With respect to word order variation, at least, the argument is that a grammar like that in (7) fails to capture the generalization that a string AB is a sentence and that at the same string but in a different order is also a sentence. The PS grammar in (7) and its analogue in the present framework claims that there is no syntactic relationship between the sentences AB and BA. This lack of generalization is magnified when more complicated grammars are developed. Within TG there is a way of stating that a S consisting of AB in that order is related to a S consisting of BA. By introducing transformations, one allows the possibility of stating rules that might apply to A in both positions by introducing a single PS rewrite rule which rewrites S as AB ( $S \rightarrow AB$ ) then moving the category A by a transformation ordered later. In this way the strings AB and BA are related in a way that they are not in a phrase structure grammar. While the transformational account does permit that sort of generalization, it requires the addition of an additional rule type of greater

power. One might legitimately ask, then, what the present framework can do about this lack of generalization.

It turns out that there are devices which, while they result in an alarming (to some) proliferation of rules, do allow generalizations of the sort available within TG but without introducing any rule type which differs in mathematical properties from the basic rules just discussed. Hence, it is possible to keep within the class of context-free languages but capture notions of sentence relatedness. Each of these devices is discussed below and their relationship to the grammar as a whole is explicated.

### 3.1 Metarules

The first kind of device to be discussed is a kind of rule schemata, dubbed "metarule" within the present framework, that allows one to make the existence of one rule dependent on the existence of another rule. Thus, a metarule allows one (potentially) to capture the notion of a basic order of constituents because one order can be taken as basic while other orders are enumerated by the output of the rule schema.

Metarules, as employed in this grammar, are inductive definitions for the set of rules in the grammar. Accordingly, Gazdar states that there will be statements of the following form: "if  $r$  is a rule of format  $R$ , then  $F(r)$  is also a rule, where  $F(r)$  is some function of  $r$ " (Gazdar (to appear b): 40).<sup>4</sup> Note that what such a rule schema does is state generalizations over the grammar. Metarules do not produce rules themselves, they simply state generalizations over already existing rules.

By way of example, let's see how this device might be used in a treatment of word order variation. Suppose that one discovers that a subject NP can appear either sentence initial or sentence final (a fact which appears to be true of Makua). Assume, for the sake of the argument that subject NPs

are to be those NPs immediately dominated by S, while object NPs are immediately dominated by VP.

9.  $\langle 1, [{}_S \text{ NP VP}] \dots \rangle$

And then, one can write the rule in (9) which simply claims that S nodes are also admitted when the order is the reverse, VP followed by NP.

10.  $\langle 2, [{}_S \text{ VP NP}] \dots \rangle$

One can state the generalization over (9) and (10) by means of a metarule of the form in (11a). (11a), in fact, will state a generalization over any other rules one might have in the grammar, such as that in (11b), and relate it to the rule in (11c). The variable X in the metarule stands for any other categories present in the rules generalized over by the metarule.<sup>5</sup>

11. a.  $\langle n, [{}_S \text{ NP X}] \dots \rangle \implies \langle n, [{}_S \text{ X NP}] \dots \rangle$

b.  $\langle 16, [{}_S \text{ NP VP Adv}] \dots \rangle$

c.  $\langle 35, [{}_S \text{ VP Adv NP}] \dots \rangle$

Metarules as employed in this thesis are therefore rule-collapsing conventions. Thus, for the example just discussed in (11a) the number of rules in the grammar will be the same even if no metarule is written. The difference lies in the kinds of generalizations that can be made by employing metarules. Below I list four ways in which metarules make syntactic generalizations possible.

(1) The rules generalized over by the output of the metarule are dependent on the input rules. On intuitive grounds, this means that one rule would not exist without the other. If one treats agentless passives, for example, by metarule as in (12) below, then one is claiming that passive verb

phrases exist only because there are verb phrases with NPs in them. If, on the other hand, one simply writes an additional rule (and that will surely not be enough) then there is no sense in which the passive VP is related to the active VP and there is no explanation as to why verb phrases without NPs (i.e. intransitive verbs) do not have a passive form.

$$12. \quad \langle n, \begin{matrix} [_{VP} & V & NP & X] \\ [-pass] \end{matrix} \dots \rangle \implies \langle n, \begin{matrix} [_{VP} & V & X] \\ [+pass] \end{matrix} \dots \rangle$$

(This is not meant to be a full treatment of the passive, of course).

(2) The metarule approach allows one to relate classes of structures that would otherwise not be related. Return for a moment to the passive metarule in (12) above. The metarule as formulated there will apply to any rule admitting a VP node provided that there is at least a V and a NP in that rule (in that order). Thus, if the grammar contains the rules in (14) below, the metarule predicts the existence of the rules in (15).

14. a.	$\begin{matrix} [_{VP} & V & NP] \\ [-pass] \end{matrix}$	15. a.	$\begin{matrix} [_{VP} & V] \\ [+pass] \end{matrix}$
b.	$\begin{matrix} [_{VP} & V & NP & NP] \\ [-pass] \end{matrix}$	b.	$\begin{matrix} [_{VP} & V & NP] \\ [+pass] \end{matrix}$
c.	$\begin{matrix} [_{VP} & V & NP & PP] \\ [-pass] \end{matrix}$	c.	$\begin{matrix} [_{VP} & V & PP] \\ [+pass] \end{matrix}$
d.	$\begin{matrix} [_{VP} & V & NP & NP & PP] \\ [-pass] \end{matrix}$	d.	$\begin{matrix} [_{VP} & V & NP & PP] \\ [+pass] \end{matrix}$

There is nothing to prevent one from simply incorporating the rules in (15) directly into the grammar without the metarule. If this approach is taken, then passive is no longer claimed to be a unified phenomenon since there is no necessary relation between the rules in (14) and those in (15). This

is just the sort of inelegance referred to in the discussion of PS grammars as standardly employed in TG. If one is willing to add the device of rule schemata to the grammar, then one of the potential objections to PS grammars is eliminated.

(3) A metarule carries over any syntactic features from the input rules unless the features are explicitly changed. Writing two rules without such a metarule linking them does not make such a consequence automatic. Thus, the passive metarule in (12) does change features explicitly (but only one). All others will automatically be carried over. The metarule proposed in (11) changes no features at all and all features are carried over automatically.

(4) Unless changed specifically by the metarule (e.g. as in the hypothetical passive rule in (12) above), but not in the metarule in (11a), all subcategorization facts will remain unchanged. No such prediction is made when one simply writes two or more rules without a metarule.

There are, then, at least four possible sorts of generalizations that can be captured by using metarules: 1) rules generalized over by the output are dependent on the input, 2) unified syntactic statements about the relatedness of structures, 3) sameness of syntactic features across sets of rules, and 4) subcategorization across subsets of rules.

### 3.2 Metarules and basic syntactic order

Since the structures predicted by the output of a metarule are dependent on the input, it is possible to think of them as more basic in a syntactic sense. To make this into a formal definition one could divide the grammar into sets of rules, those which count as inputs to a metarule and those which count as the output. However, it may be that no such formal distinc-

tion is needed, if it can be shown that the status of output rules in a grammar is necessarily different from that of the input rules, for instance, by giving a definition of a well-formed metarule which distinguishes input from output rules. Those which form the input subset then constitute the "basic order". Without metarules it will be impossible to have a syntactic statement about basic word order in a PSG. This is because if there are two syntactic rules  $[_S NP VP]$ ,  $[_S VP NP]$  in the grammar without a metarule stating generalizations over them, nothing distinguishes one as being more basic than another. These formal properties of metarules will form part of the definition for basic order in this framework. It remains to be seen whether this division results in a perspicuous analysis of Makua.

There is another subset of rules to be explored which have consequences for word order in the analysis to come. This formalism, to be introduced in the next subsection, was not set up primarily to account for order differences, (neither were the metarules), but it has consequences for order nevertheless.

### 3.3 Derived categories and derived rules

The second kind of device which allows for the specification of linear order (and which is dependent on the basic set of rules) is one which Gazdar introduces to handle unbounded dependencies. Unbounded dependencies is a cover term for those cases in which some constituent belonging semantically to a particular clause can be found indefinitely far away from the clause in which it belongs. Typical cases of unbounded dependencies involve topicalization and relativization in English. In (16a) below, the noun phrase 'this book' belongs semantically to the sentence embedded under the verb 'say'. That embedded sentence has some sort of gap in it. In (16b) the same noun phrase is found two clauses up.

16. a. This book, he said Lee enjoyed.  
 b. This book, I think he said he enjoyed.

It is generally assumed that the upper bound is only a matter of discourse, i.e. that it is less likely for a gapped constituent to appear many clauses away from the one to which it belongs semantically. In a transformational grammar the intuition that there is a gap in the embedded sentences like those in (16a) and (16b) is captured by a transformation which moves that NP out of its original position in the embedded sentence to the front of the sentence. In the present phrase structure grammar, of course, it is impossible to move anything. The approach here is to generate a gap and link it to the "displaced" NP. The treatment of unbounded dependencies within a PS grammar of the sort employed by orthodox TG was a challenge to that sort of unenriched PS grammar.<sup>6</sup> The approach developed by Gazdar however, allows the unbounded dependencies to be stated in a fairly elegant way. Here is how it works.

First of all there are the gaps. Gazdar provides a definition which creates new categories from the set of non-terminal symbols to encode the gaps. There will be such new categories as S/NP (read S slash NP) which will function as a sentence with a NP gap in it. These categories are derived categories and they are gotten by appeal to the definition in (17).

$$17. D(V_N) = \{ \alpha/\beta : \alpha, \beta \in \{V_N\} \}$$

This definition says that for every non-terminal category in the grammar there are new categories of the slashed sort. Suppose that a grammar had only the two nonterminal symbols, S and NP. The definition in (17) generates all of the following categories: S/NP, S/S, NP/S and NP/NP. Language specificity can be built in by limiting which categories  $\alpha$  and  $\beta$  can be.



Gazdar then proceeds to define a set of derived rules which employ these derived categories. The following definition defines a set of rules which admit a derived category just as the corresponding basic rule would have done for the basic category with the difference that for each rule exactly one of the dominated categories is linked to the same gapped category as the dominating category is. This will become clearer (I hope) upon investigation of the definition and subsequent discussion. Here is the definition with some accompanying commentary by Gazdar (to appear a:10).

18. Let  $G$  be the set of basic rules (i.e. the set of rules that a grammar not handling unbounded dependencies would require).

For any syntactic category  $\beta$ , there will be some subset of the set of the nonterminal symbols  $V_N$  each of which can dominate according to the rules in  $G$ . Let us call this set  $V_\beta$  ( $V_\beta \in V_N$ ). Now, for any category  $\beta$  ( $\beta \in V_N$ ) we can define a (finite) set of derived rules  $D(\beta, G)$  as follows:<sup>6</sup>

$$(9.2) \quad D(\beta, G) \{ [{}_{\alpha/\beta} \sigma_1 \dots \sigma_i / \beta \dots \sigma_n] : [{}_{\alpha} \sigma_1 \dots \sigma_i \dots \sigma_n] \\ \in G \ \& \ 1 \leq i \leq n \ \& \ \sigma_i \in V_\beta \}$$

Suppose that the set of basic rules is that in (19). The rule schema in (18) creates a set of derived rules like those in (20).

19. a.  $\langle 1, [{}_S \text{ NP VP}] \dots \rangle$   
 b.  $\langle 2, [{}_{VP} \text{ V NP}] \dots \rangle$
20. a.  $\langle 1, [{}_{S/VP} \text{ NP VP/VP}] \dots \rangle$   
 b.  $\langle 1, [{}_{S/NP} \text{ NP/NP VP}] \dots \rangle$   
 c.  $\langle 2, [{}_{VP/V} \text{ V/V NP}] \dots \rangle$   
 d.  $\langle 2, [{}_{VP/NP} \text{ V NP/NP}] \dots \rangle$

e.  $\langle 1, [_{S/V} \text{ NP VP/V}] \dots \rangle$

f.  $\langle 1, [_{S/NP} \text{ NP VP/NP}] \dots \rangle$

Note that the rule numbers stay the same for the derived rules. This insures that all facts related to verb government and subcategorization will remain the same for the derived rule as for the non-derived counterpart. In addition, no features change either. The rules in (20d) and (20f) will analyze a partial tree like that in (21) below which demonstrates how the "gap" or "hole" is passed down the tree. In movement terms, the NP/NP marks the extraction site and the slashed categories code in the extraction or movement path.

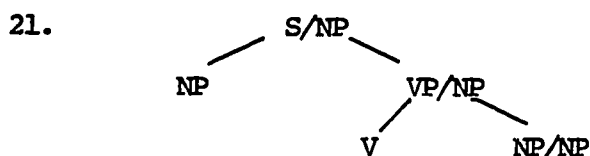

As it stands, a partial tree like that in (21) above will not fit the definition of a well-formed sentence in this PSG since it is neither rooted in S nor does it terminate in terminal symbols. So first, we need something for NP/NP to terminate in. As Gazdar suggests, this category might be realized either as a trace, (t), the empty string (e), or as a resumptive pronoun (pro) depending on the language. This could be accomplished by choosing one or more of the rules in (22) below.

22. a.  $[_{NP/NP} \text{ e}]$

b.  $[_{NP/NP} \text{ t}]$

c.  $[_{NP/NP} \text{ pro}]$

This takes care of the elimination of the derived categories.

Derived categories can be introduced by special rules of the sort in (23a) below. This rule taken together with the rules in (23b) below could,

for example, capture topicalization in English for the sentence in (16a) above.

23. a. [<sub>S</sub> NP S/NP]  
 b. [<sub>S/NP</sub> NP VP/NP]                    [NP/NP t ]  
     [<sub>VP/NP</sub> V  $\bar{S}$ /NP]  
     [ $\bar{S}$ /NP COMP S/NP]  
     [<sub>VP/NP</sub> V NP/NP]

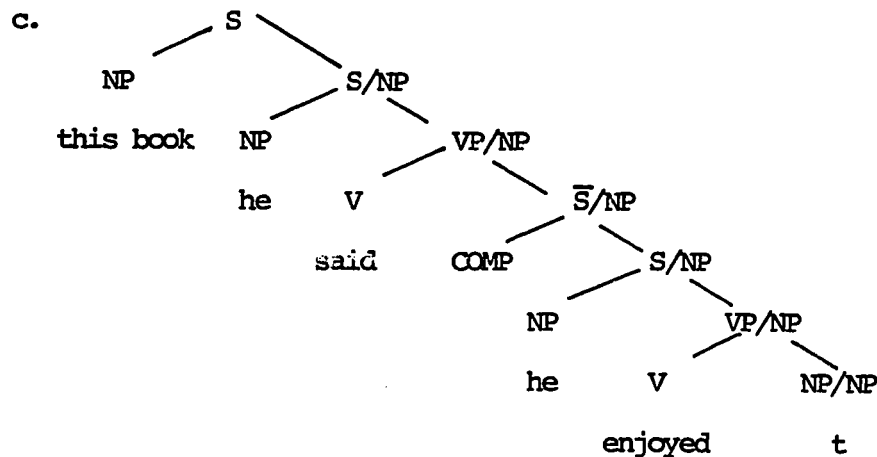

The rules eliminating the derived categories and those introducing derived categories (e.g. (22) and (23a) above) are called linking rules because they link derived categories to the S node on the one hand and to terminal symbols on the other. The use of these linking rules together with the derived rules and derived categories are the mechanisms by which unbounded dependencies are treated within this PSG.<sup>7</sup>

Before defining the basic order with respect to metarules and these derived rules, I would like to point out one further difference between the two devices. The kinds of generalizations over rule sets made by the in-

ductive metarules as opposed to the generalizations made by the derived rule schema in (18) are slightly different. Metarules can change syntactic features (e.g. as in the passive rule proposed in (12) above). Rules generalized over by the derived rule schema by definition cannot. In addition, since the rule numbers of rules generalized over by the input rules are necessarily different from the output rules, it is to be expected that sometimes the items dominated by a particular node will be different for the input rules and the output rules (e.g. passive versus active verbs). Derived rules cannot differ from their associated non-derived counterparts because the rule numbers are necessarily the same. I will detail further differences between the metarules and derived rules in Chapter 4.

In addition to capturing facts about unbounded dependencies, derived rules together with linking rules can allow for different linear orders to arise. The effect of the topicalization linking rule is to admit a S with a NP in front of another S/NP. Because the total interaction of the derived rules with the linking rules depends on the existence of the basic rules ( $R_G$ ) it is possible to specify orders induced by the use of derived categories (the linking rules in conjunction with the derived rules) as distinct from those enumerated by the basic rules.

There is now at least the possibility of defining a basic syntactic order within this framework: that order induced by rules which 1) contain no derived categories and 2) are not enumerated by the output of a metarule. The motivation for choosing the basic order would be in part supported by evidence that some syntactic statements rely on the distinction between unbounded dependencies while some do not, and evidence regarding the choice of input vs. output of metarules.

It is important to point out that there are at least four reasons why this definition of basic order might not be valid for the present version of PSG. First, as Gazdar (personal communication) pointed out to me, the notion of a basic order is obscured by an analysis of VSO order which maps PS rules into S rules by metarule. Because the VP rule is the input rule, it claims that VO order is basic. This sort of analysis has been proposed for Breton by Gazdar and Sag (to appear). Such an analysis of VSO order also figures into Makua syntax. This point will be elaborated in Chapter 4. Secondly, freedom of constituent order may be defined by a rule collapsing convention that completely vitiates the definition of basic order provided in this chapter. This point will be taken up in Chapter 4 as well. Thirdly, there is little evidence that anything in the analysis of Makua syntax presented in Chapters 4-6 of this thesis depends on one order as basic rather than another. The consequences of this finding are discussed in Chapter 7. Finally, traditional linguistic arguments for establishing a basic order have rested on other criteria than purely syntactic ones, for example, typological factors. In the next section of this chapter, six of these criteria are taken up and compared to the syntactic definition of basic order just given.

#### 4. Six common criteria used to establish a basic order

##### 4.1 Introduction

In the preceding section it was shown how, within the framework being explored in this thesis, it would be theoretically possible to pick out just one syntactic order and call it basic. The term basic order (or its analogue, canonical order) is used by linguists to pick out other distinctions than the syntactic one just outlined. It is used, for example, for the unmarked or

neutral order. In other contexts it is used for that order in languages in which only one order can be used in situations of potential ambiguity. In still other contexts, the term basic order may be used for that order which best fits typological correlations of the sort first noted by Greenberg. The working assumption seems to be that the unmarked order ought to be the same as the typological order which ought to be the same as the one used in ambiguous contexts, and that all of these ought to be the same as the syntactic one.

I am not going to challenge the validity of this working assumption, although it may occur to some after the discussion to follow that this assumption ought to be challenged. Rather, I would like to explore the assumptions that would have to be made in order to claim that the basic syntactic order is the same one determined by six criteria, the three just mentioned and, in addition, to criteria related to frequency, comparative evidence, and the order appearing in a restricted syntactic class of contexts. Then, each of these criteria are applied to the Makua data in order to establish what the results are (if any) for the choice of a basic syntactic order for Makua.

Although the discussion of a syntactic basic order is couched within the terms of the phrase structure grammar being investigated in this thesis, the remarks made will generalize to most other syntactic definitions of a basic order. In particular, most of the observations with respect to the assumptions to be discussed will hold for a transformational model in which the basic order is that defined by the phrase structure rules (i.e. the underlying order) as opposed to any orders derived by transformation.

#### 4.2 Word order and clause types

Of the six criteria commonly used to establish a basic word order, the first one has the most obvious relevance to the definition of a syntactic word order per se. It is sometimes the case that word order variation in a particular language is permitted only in a syntactically definable subset of clause types. An example of this state of affairs is Aghem, a Grassfields Bantu language spoken in the Cameroons, as described by Watters (1979). In Aghem, word order is relatively free in main clauses, while there is the same fixed order in relative clauses, subordinate clauses, constituent questions and imperatives. The argument advanced in this case is that that fixed order is the basic one. For this argument to be a valid one with respect to a syntactic basic word order, it should be the case that the choice of this order makes the syntax simpler and more general. It is easy to see how this might be the case in a transformational grammar where one could simply stipulate the putative basic order by means of the phrase structure rules, and then restrict movement rules achieving the word order just to main clauses. This restriction to main clauses follows the distinction set out by Emonds (1976) which defines a root sentence as those sentences which are not dominated by any node other than S. Presumably, the same distinction could be made in the present framework since, to date, relative clauses, constituent questions and subordinate clauses are all dominated by nodes other than S (R, Q and  $\bar{S}$ , respectively) analogous to treatments within the transformational paradigm.

In addition to the distinction between Root Sentences and other clause types, it would be necessary to show that syntactic processes, in fact, are stated more generally on the putative basic order, i.e. that order found in

the restricted clause types.

If it were the case that the distinction between Root Sentences and other clause types were needed only for these statements of order then it would be a complication to make the distinction. However, there is ample evidence that such a division is necessary (see Emonds (1976) for such evidence) so that it could be exploited for cases like Aghem.

Makua syntax offers little in the way of evidence for a basic syntactic order of different clause types. First, word order is quite free in main clauses as illustrated by the following examples in (24) in which all six logical permutations of subject, verb, and object are possible.

24. a. SVO  
 Hín - Sepété áhó- túpúl - a nk<sup>h</sup>áculé  
 Sepete sa/t - cut - t cashew nut tree/dem  
 'Sepete cut down the/that cashew nut tree'
- b. OVS  
 nk<sup>h</sup>áculé áhó - túpúl - a Hín - Sepété  
 'the/that cashew nut tree, Sepete cut (it) down'
- c. SOV  
 Hín - Sepété nk<sup>h</sup>áculé áhó - túpúl - a  
 'Sepete did cut down the cashew nut tree (as we expected him to)'
- d. OSV  
 nk<sup>h</sup>áculé Hín - Sepété áhó - túpúl - a  
 '(about) the/that cashew nut tree, Sepete cut (it) down (as we expected him to)'
- e. VSO  
 áhó - túpúl - a Hín - Sepété nk<sup>h</sup>áculé  
 '(what happened was that) Sepete cut down the/that cashew nut tree'
- f. VOS  
 'áhó - túpúla nk<sup>h</sup>áculé Hín - Sepété  
 '(what happened was that) Sepete cut down the/that cashew nut tree'

The same permutations are possible in embedded sentences as well, as illus-



trated by examples like those in (25).

25. a. SVO  
 áhó - káá - minih - á wiirá Hín - Sepété áhó - tupúl - á  
 sa/t- oa/ convince - t that Sepete sa/t - cut - t  
 nk<sup>h</sup>áculé  
 cashew nut tree/dem  
 'S/he convinced me that Sepete cut down the cashew nut tree'
- b. OVS  
 áhó-káá-minih-á wiirá nk<sup>h</sup>áculé áhó-tupúl-á Hín-Sepété  
 'S/he convinced me that the/that cashew nut tree, Sepete cut  
 (it) down'
- c. SOV  
 áhó-káá-minih-á wiirá Hín-Sepété nk<sup>h</sup>áculé áhó-tupúl-á  
 'S/he convinced me that Sepete did cut down the cashew nut  
 tree (as we expected him to)'
- d. OSV  
 áhó-káá-minih-á wiirá nk<sup>h</sup>áculé áhó-tupúl-a Hín-Sepete  
 'S/he convinced me that (about) the/that cashew nut tree,  
 Sepete cut (it) down (as we expected him to)'
- e. VSO  
 áhó-káá-minih-á wiirá áhó-tupúl-á Hín-Sepété nk<sup>h</sup>áculé  
 'S/he convinced me that (what happened was that) Sepete cut  
 down the/that cashew nut tree'
- f. VOS  
 áhó-káá-minih-á wiirá áhó-tupúl-á nk<sup>h</sup>áculé Hín-Sepété  
 'S/he convinced me that (what happened was that) Sepete cut  
 down the/that cashew nut tree'

Imperatives, likewise, permit word order variation. One form of imperative verb in Makua consists of the subject prefix for 'you' (either the initiated or uninitiated form), followed by the verb stem suffixed by e. As illustrated in (26) below, the object may precede or follow the imperative verb. No clear-cut functional difference is ascertained in these examples.

26. a. Imp. DO  
 ntupúl-é ik<sup>h</sup>uni- ciyó  
 sa/cut-mood firewood-dem  
 'cut the/that firewood'



a few introductory comments are necessary here. Relative clauses are not marked differently from main clauses (although there is the restriction on tense and aspect morphology noted in Chapter II, Section 5). There is no WH-word or complementizer present. Sometimes Bantu languages exhibit a tonal pattern in relative clauses distinct from that in other clause types, but this is not the case in Makua. The "gap" in the relative clause always corresponds to a NP, hence, there is no relativization out of prepositional phrases. In addition, any relativized NP triggers agreement on the relative clause verb. There are other interesting (and important) morphological properties of relative clauses, but I won't discuss these here.

One restriction on order in relative clauses is in the case of subject relativization. The restriction is that nothing can intervene between the head NP and the relative clause verb. Thus, no object NP, no adverb, etc. belonging to the relative clause can precede the relative clause verb. No such restriction holds for other clause types. The order restriction in this sort of relative clause is illustrated by the grammaticality of the example in (28a) and the unacceptability of examples like those in (28b-c) where an object and a VP adverb intervene between the head NP and the relative clause verb, respectively.

28. a. head V O Adv.  
 nt<sup>h</sup>ú colum - ílé milát<sup>h</sup> - úlé ráta ...  
 person sa/t/arbitrate-t disputes-dem well  
 'the person who arbitrated disputes well...'
- b. \*head O V Adv  
 nt<sup>h</sup>ú milat<sup>h</sup>-úlé colum-ílé ráta
- c. \*head Adv V O  
 nt<sup>h</sup>ú ráta colum-ílé milát<sup>h</sup>-úlé

The first question to be answered is whether this restriction should be

a syntactic one, i.e. whether the syntactic analysis of Makua should predict the unacceptability of examples like that in (28b-c). It is impossible to give a definitive answer to this question at this point, but I would like to point out at least two reasons why it might be the case that non-occurrence of examples like those in (28b-c) is not the result of some syntactic interaction. One is that there could be some discourse function associated with relative clauses, on the one hand, and the order XV (X = any category) on the other, such that they conflict with each other. I haven't been able to refine the definition of discourse functions sufficiently to predict this, but given that this kind of interaction is prevalent in the language, such an analysis cannot be ruled out. Another possible explanation is that there is something about processing such structures that makes them unlikely to occur. It could be that the verb is taken to be an indication that a relative clause is coming. There is some slight evidence from the second restriction, to be discussed shortly, which is suggestive of this sort of constraint.

The second question is that if this restriction in subject relatives did arguably turn out to be a syntactic one, would it be indicative of any basic order? On the assumed grounds that restricted orders in clause types are indicative of a basic order, then one might suppose that at least VX is to be preferred over XV.

In the second case, regarding the constraint in order in relative clauses, the offending order is found in examples where a non-subject NP has been relativized. When the head of the relative clause is the second of two NPs in a row, the subject of the relative clause must appear after the verb. Compare the examples in (29).

29. a.  $V_1$  NP head  $V_2$  NP  
 káhó - váh - á ikitáábw - aáká nténgá  
 sa/t- give - t books-poss messenger  
 aa - rum - íly- ááyá Hín - Sepété  
 sa/t-send-t-ag.suff. Sepete  
 'I gave my books to the messenger who Sepete sent'
- b.  $*V_1$  NP head NP  $V_2$   
 káhó-váh-á ikitáábw-aáká nténgá Hín-Sepété aa-rum-íl-ááyá

However, when one of the same NPs is preceding the main clause verb, no such restriction is in effect. This is illustrated in the example in (30) which shows that the subject of a relative clause may either precede or follow the relative clause verb. It is certainly the case that the preferred position of the subject NP is following the verb. (However, this is true of all examples in which a non-subject is relativized).

30. a. NP  $V_1$  head NP  $V_2$   
 ikitáábw-aáká káhó-váh-á nténgá Hín-Sepété aarumíly-ááyá  
 'my books I gave to the messenger who Sepete sent'

One can ask the same two questions with respect to this restriction as one did for the preceding restriction. First, is it the case that this restriction is, strictly speaking, syntactic? And, again, it is hard to tell. Given that there seems to be a simple restriction on the number of NPs allowed in a row when a relative clause boundary intervenes, it seems plausible that the restriction is one which (if it is syntactic) is best analyzed as a filter which would disallow certain sequences. There is, in addition, the option that the discourse functions somehow conflict as well. I do not have an analysis of these facts, but this lack of analysis does not prevent one from asking a further question.

The second question that is to be addressed is that if this restriction

turns out to be characterizable in syntactic terms, then which direction does the evidence point to with respect to the choice of a basic syntactic order? It is suggestive of a VSO or VOS order at least, given that those orders are always permitted in a relative clause. Whether or not the adoption of either VOS or VSO order as basic buys anything in the syntactic analysis remains to be seen. However, it should be kept in mind that these restrictions might not be essentially syntactic. Therefore, these facts don't necessarily provide the sort of evidence from restricted orders in clause types that is required by the argument being investigated here.

In summary, then, it seems as though, in clear cases, the choice of a basic syntactic order might be aided when the language in question has clear cut syntactic divisions of the sort exhibited by Aghem, but that the evidence from Makua is far from revealing.

#### 4.3 Marked vs. unmarked order

The argument that of two orders, one marked, and the other unmarked, it is the unmarked order which is basic, has some intuitive appeal. It is not at all clear, however that it necessarily follows that the unmarked order ought to be syntactically more basic. One could, of course, define unmarked order to be just that order which corresponds to the basic syntactic order. In general, even those linguists who subscribe to that definition have in mind phenomena related to suprasegmental phenomena, such as intonation, and discourse function, neither of which is necessarily related to the present definition of syntactic basic order. Both of these phenomena, indeed the whole marked vs. unmarked distinction, rest on the assumption that it is possible to define for a language some notion of normal pattern. The assumption that there are normal patterns can be challenged on the grounds that such

an assumption obscures governing principles.<sup>8</sup> Nevertheless, the notion is such a common one that it merits discussion. I will take up two sorts of phenomena with respect to Makua, and I hope to show how, even if it is possible to define a difference, certain assumptions have to be made in order for that difference to reflect anything about basic order. Secondly, the evidence from discourse function suggests that it is far from easy to pick out an unmarked order, and that such orders may have more to do with the state of the world than they do with syntax per se.

For the sake of the argument then, I will look at suprasegmental evidence and discourse function to illustrate that the orders are not equivalent for subjects and objects, at least.

I shall not have much to say about the relationship of word order to stress since I have done no thorough examination of that part of the system. There is another intonational pattern, however, that is a little more accessible and that is a matter of pause intonation. In the case of pause, two things happen: one is that the vowel coalescence that appears across word boundaries is suspended and, two, if the final high tone on the item before the pause is a copy, and not a basic high, it is phonetically low (i.e. the utterance final lowering rule comes into play). What is relevant here is a difference between subjects in SVO order and objects in OSV order as illustrated by the examples in (31) below. A subject in initial position has no special properties associated with it. Vowel coalescence may take place across the SV boundary. Tone phenomena are normal. A subject does not need any special morphological marking. But there are some restrictions on objects in this position. They are either generics (and hence definite in one sense), nouns marked by a demonstrative suffix (indicating that the speaker expects

that the hearer has some prior knowledge of the object in question) or, if the object is not marked as indefinite or is not a generic, then the object is set off by a pause.

31. a. SVO  
 mmíráwo áhó-th<sup>h</sup>úma-á ikitáábu  
 'a boy (as expected) bought a book'
- b. OVS  
 ikitáábu, áhó-th<sup>h</sup>úma mmíráwo  
 'a book, a boy bought (one)'

In one sense, the object is more marked in sentence initial position than is a subject because it has these extra requirements. Subjects are generally interpreted as definite, but this is because they are tied to a position in which information is not novel. (I will return to the discourse function of the orders shortly). The point is that objects need that extra marking, i.e. a demonstrative or a pause, while subjects do not. The presence of a pause in OSV sentences, but not in SVO sentences is suggestive of a syntactic analysis that differentiates the two structures and that analysis might be taken to be the difference between a basic and a nonbasic order in the syntactic sense.

A second kind of evidence for a marked vs. an unmarked order is that of discourse function. That is, it is often the case that one order requires a more explicit context in order for it to be acceptable. This order is then taken to be the marked one. This notion rests essentially on the assumption that some situations are more likely to occur than others, a fact that is surely true about the world. Any assumption that makes the unmarked order syntactically basic is in fact building a lot of information about the world into the syntax. It would be nice if this sort of metaphysical claim



turned out to be right, but I don't think it makes a very sound syntactic argument.

In spite of the tenuous link between unmarked order in the discourse function sense and the basic order in the syntactic sense, I would like to take some space to lay out some very simple examples from Makua and show how their orders are in fact related to discourse function. It will, I think, alleviate some people's worries about how a language like Makua actually works.

In the examples in (32) below, I have used a tense that translates as the English simple past. This tense is one of those mentioned in Chapter II that does not have associated with it any notion of contrastive focus. It cannot be used for constituent questions, relative clauses, etc., but it can be used in declarative sentences and embedded sentences. At the risk of sounding impossibly vague I will say that this tense is simply used to indicate that the action took place. Within this tense (and the others that share its syntactic idiosyncracies) it is possible to view the organization of it along the lines of topic-comment. If there is an NP at the beginning of the sentence, then that NP is what is being talked about (i.e. the topic). In a discourse, for example, the first NP will have been discussed prior to this sentence. The rest of the sentence then constitutes a comment. The organization within the comment is, so far as I can tell, based on putting novel information after the verb and expected information before the verb. What this translates into with respect to the notions of subject and object is whether the speaker judges that the hearer is likely to know who bears what relation to the verb. That is, the information is novel not just because it is new in the discourse (although it may be) but because the speaker judges

that the hearer knows the grammatical relation of the NP. This will become clearer as the examples are discussed. Because demonstratives may be used either to refer to an object where the object is present or used to refer to the object that has been mentioned before, their presence makes a great deal of difference in the interpretation given.

The use of a sentence like (32a) goes roughly like this. Sepete is being discussed and the sentence tells what he did. The demonstrative on the object NP is likely to get a first reading that the tree is visible. This correlates with the position of the object NP in that it follows the verb and is likely to be novel information. In the (b) example the cashew nut tree is the topic of the conversation. Either reading of the demonstrative is likely. What is being said about the cashew nut tree is that it was cut down and that Sepete did it. In (c) on the other hand, Sepete is the topic of conversation and the report is that he cut down the tree as expected. The demonstrative in this case is likely to be used when the object is not present in accordance with the report-like status of the sentence. In (d) both the object and the subject precede the verb. The tree is being talked about and what the sentence says is that it was cut down by Sepete as expected. The examples in (e) and (f) seem to be similar in function. Both are simply neutral reports (the consultant's judgment meaning no assumptions necessary) about something that happened. The difference is slight in these last two examples but the example (e) in which the object comes last seems to indicate more surprise on the part of the speaker that he cut down a cashew nut tree. In this case it is pretty clear that the two NPs are both novel information and consequently, the demonstratives are more likely to be interpreted as pointing to a tree that is visible. If there are demonstratives on that noun,

then the likely interpretation is that the tree is there (much in the same way as in the first example).

32. a. SVO  
 Hín - Sepété áhó - túpúl - a nk<sup>h</sup>áculé  
 Sepete sa/t - cut - t cashew nut tree/dem  
 'Sepete cut down the/that cashew nut tree'
- b. OVS  
 nk<sup>h</sup>áculé áhó-túpúl-a Hín-Sepété  
 'the/that cashew nut tree, Sepete cut (it) down'
- c. SOV  
 Hín-Sepété nk<sup>h</sup>áculé áhó-túpúl-a  
 'Sepete did cut down the cashew nut tree (as we expected him to)'
- d. OSV  
 nk<sup>h</sup>áculé Hín-Sepété áhó-túpúl-a  
 '(about) the/that cashew nut tree, Sepete cut (it) down (as we expected him to)'
- e. VSO  
 áhó-túpúl-a Hín-Sepété nk<sup>h</sup>áculé  
 '(what happened was that) Sepete cut down the/that cashew nut tree'
- f. VOS  
 áhó-túpúl-a nk<sup>h</sup>áculé Hín-Sepété  
 '(what happened was that) Sepete cut down the/that cashew nut tree'

To substantiate the suggested analysis, one would, of course, need to do a lot of testing with a lot of speakers. The point is that it is not particularly hard to come up with contextual distinctions separating out the orders and that in some ambiguous cases these discourse functions will help. This is particularly apparent in situations where two NPs (or more) precede the verb. Since they are likely to be expected or old information in this position their grammatical role will not be in question in a real context. This will not be the case with respect to NPs after the verb where, in general, interpretation of the sentence is more rigidly fixed in ambiguous

sentences. NPs following the verb, recall, are new in the sense that their grammatical relation to the verb is not known. Discourse context will provide little aid in disambiguating such structures.

From such limited data it is hard to decide what is a marked and what is an unmarked order. The consultant's judgements are that all of the sentences are pretty good and that the VOS sentence is the most neutral of all (i.e. requiring no prior discourse), but that the SVO sentence is more normal (i.e., more likely to occur). Thus, intuitions are not enough and this seems to be an area of grammar best left to study by native speakers of the language.

One is tempted to say, given the Makua evidence, that the marked vs. the unmarked distinction only holds out of context and it is the contexts themselves that are marked or unmarked in the sense that some situations are less likely to arise. Establishing an unmarked order with respect to discourse function then will still not be sufficient to justify a syntactic order without the metaphysical claim alluded to above. It may turn out that the "best" syntactic analysis is one in which the basic syntactic order is correlated with the unmarked order. To the extent that this is true cross-linguistically the assumption that the two orders are to be the same will be substantiated.

#### 4.4 Ambiguity and preferred readings

Another kind of argument employed in order to establish a basic order is one based on preferred readings in potentially ambiguous structures. Suppose a NP V NP sentence is potentially ambiguous between two readings, SVO and OVS. Then a common assumption made is that the preferred reading (or, in some cases the only reading) is representative of the basic order.

One finds, for example, the following sort of discussion in the literature.

Thus, in a German sentence such as Die Mutter sieht die Tochter, in which the inflections do not suffice to indicate grammatical function, it seems that the interpretation will invariably be that "Die Mutter" is the Subject (unless it has contrastive stress, in which case it may be taken to be the Subject or the Object). The same seems to be true in other languages as diverse as Russian (cf. Peshkovskii, 1956, p. 42) and Mohawk. In the latter, the Verb contains affixes designating Subject and Object, but where the reference is ambiguous, the initial NP is taken to be the Subject, unless under normal intonation (I am indebted to Paul Postal for this information). If this is universal, it suggests the generalization that in any language, stylistic inversion of "major constituents" (in some sense to be defined) is tolerated up to ambiguity — that is, up to the point where a structure is produced that might have been generated independently by the grammatical rules.

(Chomsky 1965: 126-7)

Because Makua does not have case marking, it is more like Mohawk (among the cases discussed in the preceding quote). Just in case the subject and object NPs in Makua (and the indirect object or causee for that matter) are of the same noun class, verb agreement will not serve to disambiguate the grammatical relations of those NPs. If those cases are tested out of context, one finds that there is a preferred reading. However, it is not the case that the order is as rigidly fixed as it is in German. This is because there is so much discourse information relayed by the order of the elements in Makua that it is possible to set up a context in which the less preferred reading becomes the dominant one.

In order to demonstrate how the choice of context influences the readings, I will use a sentence containing only two NPs and a verb, where the NPs are of the same noun class, so that there will always be a potential ambiguity. Here I have to make some comment about how this sort of data was collected and what it may be indicative of. First, the data are for only one speaker. Surely for this evidence to be conclusive, one would have

to do this sort of research much more rigorously and with many more speakers. It is suggestive of this one speaker's strategy in that the examples were repeatedly tested over a two year period and the readings stayed constant.

The sentences in (33) below were tested initially out of context.

The speaker was asked to translate the sentence and in each case, if there were two readings possible, to rank them. Here are the results of a paradigm.

33. a. NP V NP  
 Hín-Sepété áhóón - á Araárima  
 Sepete sa/t/oa/see-t Araarima  
 i. SVO 'Sepete saw Araarima'  
 ii. \*OVS 'Araarima saw Sepete'
- b. NP NP V  
 Hín Sepété Araárima áhóón-á  
 i. SOV 'Sepete saw Araarima'  
 ii. OSV 'Araarima saw Sepete'
- c. V NP NP  
 áhóón-á Hín-Sepété Araárima  
 i. VOS 'Sepete saw Araarima'  
 ii. VSO 'Araarima saw Sepete'

Note that one order NP V NP had only one reading, SVO. The remaining two orders had both readings although in each case one reading was clearly preferred. The second reading can be made dominant for (33b), for example, by simply introducing an appropriate context. If someone asserts that Sepete did not see Araarima then a speaker could reply using (33b) and it would be the second reading which is preferred. Likewise, even the reading OVS for (32a) which is not allowed at all out of context, can be made to arise by the question and answer sequence in (34) below.

34. a. apání óón-íle Hín-Sepété  
 who sa/t/oa/see-t Sepete  
 'who saw Sepete?'
- b. Hín-Sepété óón-íle Araárima  
 'it was Araarima who saw Sepete'

A better answer would be simply to give the name alone, of course, but this fuller answer is also plausible because the focus position for answers to constituent questions is that position immediately following the verb (in addition to the requirement that a specific sort of tense/aspect marker is used).

Other results for ambiguous sentences are obtained when other pragmatic factors are juggled. If the NPs are of the same class, for example, but the selectional restrictions of the verb are such that an inanimate object is preferred then the readings will, in general, be in accordance with the selectional restrictions. Thus, in sentences like those in (35) where for a person to buy a bicycle is more likely than for a bicycle to buy a person, the readings are consistent with the selectional restrictions, and only under pressure will the consultant admit to a second reading.

35. a. NP V NP  
 báásikely - úlé áhó - í - thúm - a Hín-Sepété  
 bicycle - dem sa/t-oa- buy - t Sepete  
 i. ?SVO 'the/that bicycle bought Sepete'  
 ii. OVS 'the/that bicycle Sepete bought'
- b. NP NP V  
 báásikely-úlé Hín-Sepété áhó-í-thúm-a  
 i. ?SOV 'the/that bicycle bought Sepete'  
 ii. OSV 'the/that bicycle, Sepete bought'
- c. V NP NP  
 áhó-í-th<sup>h</sup>uma báásikely - úlé Hín-Sepété  
 i. VOS 'Sepete bought the/that bicycle'  
 ii. ?VSO 'the/that bicycle bought Sepete'

While the above two sources of disambiguating information (discourse context and selectional restrictions) do not exhaust the kinds of information that I think the language consultant used, the point is still clear. The notion of ambiguity is not, in the case of Makua, a simple interaction between

word order and morphology (i.e. lack of agreement differences) but is a complex of many factors. There are probably some real constraints on how the language is used, but only careful investigation of all the relevant factors would reveal those constraints.

One question that arises with respect to an argument from ambiguity is what exactly one is testing when the sentences are used out of context. The assumption seems to be that it is indicative of something essentially syntactic. This assumption ought to be questioned, since it could be the case that such examples are reflective of a simple parsing strategy which may or may not be in accordance with the syntax. If, on the other hand, one maintains the assumption that readings out of context do reflect in some way a basic syntactic order, then the question arises as to whether there is any evidence from the data just discussed which would be indicative of a basic order. So far, the NP V NP structures stand out from the others in that they get only one reading, and it is always SVO. I am reluctant to conclude anything at all about this order for at least two reasons (in addition to the possibility that it could be reflective of an out-of-context parsing strategy). One is that the speaker knows both Swahili and English, which have much more rigidly fixed orders (to all accounts SVO). In addition, the research was conducted in English. To what extent this sort of fact can influence the results is not known, but it seems possible that it could. Furthermore, from what I have been able to ascertain about the discourse function of word order in Makua, it appears that the initial NP is taken to be the topic. If this is the case, and if, as has been often asserted, subjects make better topics, then this explanation alone could account for the likelihood of SVO readings.



There are several points to be made here. First, it is not entirely obvious that readings out of context are, in fact, indicative of the basic syntactic order, since there are other potential explanations for those choices which lie outside sentence syntax proper. Further, even if the assumption that basic syntactic order is to be that order which surfaces in ambiguous situations then the data from Makua are still fairly inconclusive.

#### 4.5 Frequency

Often (particularly in the case of free order languages) the argument is advanced that the more frequent order in texts is the basic one.<sup>9</sup> There are several problems with this argument. First, how frequent is frequent enough? Secondly, if word order reflects discourse functions, and some discourse functions are more likely to occur than others, the frequency of a particular order would be reflective of this other state of affairs. Now if the assumption is to be that the normal state of affairs in the world is to be in a one-to-one correspondence with basic order, then it is possible to use frequency as a kind of criterion. This assumption may be a questionable one. Without such a link, however, text frequency counts are not going to be suggestive of a syntactic basic order.

The text sample we have available for Makua is a small one at this time, and not representative of the kind of variety one would require for such an analysis. For this reason, then, I will not introduce such evidence here.

#### 4.6 Typological criteria

In addition to the sorts of evidence discussed in the preceding four

subsections, a fifth, typological correlations, is often brought to bear on the establishment of a basic order for a particular language. The arguments from typological evidence generally go like this. Greenberg (1972) demonstrated statistically significant generalizations across morphemes and word order across a variety of languages. He then set up a basic order typology (in which the crucial elements are subject, object and verb) for which a number of (largely implicational) universals were proposed. One finds, for example, the following statement.

Universal 4. "With overwhelmingly greater than chance frequency, languages with normal SOV order are postpositional."

(Greenberg: 1972: 334)

It is not uncommon for linguists to use these correlations to aid in choosing a basic order for a given language. The question I want to raise is whether the evidence from typological correlations could be used to pick a syntactic basic order, in particular, under the definition proposed for the framework under investigation in this thesis.

Outside of the fact that there are often not enough typological correlations to decide conclusively among the orders for a given language, there are other issues to be addressed. Note first that these implicational universals rest on the assumption that there is a single basic order (either "normal" or "dominant" in Greenberg's terminology). It would be important to know for each language on what grounds this dominant or basic order was chosen, whether or not it was by sheer inspection of text frequency or by some other combination of the criteria discussed in preceding sections of this chapter. Without consideration of these facts, it is difficult to evaluate what merit using typological correlations would have for the choice

of a basic syntactic order as I have defined it. Even with this problem aside, there is a further assumption that ought to be investigated. Using typological correlations to justify the choice of a particular basic syntactic order rests on the assumption that the order indicated by typological criteria should be the same order as that chosen as the syntactic basic order within a particular theoretical paradigm. I would like to question this assumption on two grounds, one that the correlations noted by Greenberg are not (with one possible exception to be discussed shortly) built into most syntactic theories that I am aware of. Dowty (to appear) is a clear exception to this claim. Secondly, insofar as there are alternative accounts which may lie outside of sentence syntax proper, the above assumption is weakened somewhat.

The first reason why the jump in claiming the same typological and syntactic basic orders might not be merited is that while typological correlations incorporate relative order of subject, verb, object and grammatical categories as prepositions, interrogative particles and auxiliaries, these correlations are rarely built into a syntactic theory. Thus, there is nothing within the present framework, for example, which claims in accordance with Universal 12 that VSO languages put interrogative words or phrases in initial position for interrogative word questions. Without such links, however, it does not follow that a typological basic order is necessarily the same as a syntactic basic order. It is even questionable whether one wants syntactic theory to be formulated in such a rigid fashion, since the correlations are only statistical. One could imagine that a theory might be formulated so that a grammar is more highly valued if the correlations do fall out. The point is that part of the typological argument rests on such assumed

correlations, but that these do not (in most cases) follow from the syntactic theory in question. One possible exception to this last rather general claim is Jackendoff's (1977) development of  $\bar{X}$  syntax. He notes that some of the universals suggest an evaluation measure for PS grammars that count parallelisms of word order over  $X^n$  (e.g. a grammar in which all modifiers either follow or precede their head nouns is simpler than one in which some precede and some follow). But he also suggests that while parallel grammatical relations with differing orders across  $X^n$  seem to generalize (although these correlations are not as strong), present notations do not express this (Jackendoff 1977:85). To the extent that  $\bar{X}$  notation is adopted by the present framework the same comments hold but only for the basic order.

The alternative account for the Greenbergian correlations that I have in mind, are of the sort mentioned by Frazier (1979). Frazier claims that certain structural properties of languages may be explained by the parser model she proposes. For example, she suggests that the correlation between VSO languages and postpositions and SOV languages and prepositions may be tied to the role such adpositions play in parsing (Frazier 1979:129-130). In this way, the typological correlations would have something to do with language processing. Whether this turns out to be an argument against assuming that typological basic order is the same as syntactic basic order, depends on one's theoretical claims about the interactions of syntax and parsing.

The point of this discussion is that it is risky to simply rely on typological correlations in choosing a syntactic basic order because 1) it is unclear what criteria were used to establish basic order in the development of the typological universals themselves, 2) syntactic theory makes few (if

any) claims about such correlations explicit and 3) other factors than strictly syntactic ones may offer an account for the existence of these correlations.

The immediately preceding discussion has been aimed at making clear the assumption underlying a claim that the order indicated by typological correlations of the sort noted first by Greenberg ought to be the same order as a basic syntactic order as defined within a particular syntactic theory. Even though there is some question whether these orders are necessarily the same one in a given language, I will go ahead and discuss some of the relevant universals with respect to Makua. It turns out that the conclusions are relatively indecisive in this regard, since the universals are not numerous enough to actually pick a single order. At the very least, the data discussed below provides some facts about Makua syntax.

The presentation of the universals centers around those which relate to the order of subject, object, and verb as correlated with other grammatical categories. Those universals pertaining to SOV and OSV are examined first, and it is shown that universals associated with these two orders show the fewest correlations to Makua.

First, there is the matter of postpositions vs. prepositions. As Universal 4 states, "With overwhelmingly greater than chance frequency, languages with normal SOV order are postpositional." (Greenberg (1972)). Makua, like many other Bantu languages, has few prepositions. One morpheme which could legitimately be called a preposition is wa 'to'. While historically this morpheme probably consisted of a locative prefix u- and the genitive -a, its synchronic behavior suggests that it is analyzed as a single morpheme. When used as a preposition, wa (as in (36) below) always precedes the noun.

36. Aráárima áhó - rweéh - a ibáruwa wa mwaárimw - aáyá  
 Araarima sa/t- send - t letter to teacher - poss  
 'Araarima sent a letter to his teacher'

Not only does the preposition precede the noun, it cannot be separated from its noun.<sup>10</sup> Hence the word order of prepositional phrases (like that of noun phrases) is fixed. In fact, there appears to be no extraction out of prepositional phrases. Thus, the attempt to relativize out of the prepositional phrase will be unsuccessful, as illustrated by the example in (37) below.

37. \*mwaárimu Aráárima aa - rweéh - íy- aáyá ibáruwa wa ...  
 teacher Araarima sa/t- send - t - ag.suff. letter to  
 'the teacher who Araarima sent a letter to'

Another candidate for prepositional status is the all-purpose morpheme ni- 'by, with'.<sup>11</sup> Like wa, ni- cannot be separated from its noun phrase which always follows. And as in the case of wa- no extraction out of such prepositional phrases is permitted. Compare the examples in (38) and (39).

38. a. ílémátélá yáhó- lím - íy - a ni - Hín-Sepété  
 dem/field/dem sa/t-cult.-pass-t by-Sepete  
 'this field was cultivated by Sepete'
- b. Hín-Sepété a-no-túpúl-a nth<sup>h</sup>ále ni-mwaáló  
 Sepete sa-t- cut - t bamboo with-knife  
 'It's bamboo that Sepete is cutting with a knife'
39. a. \*Hín-Sepété {yaa}- lím -íyé ílémátélá ni  
 {aa} Sepete sa/t -cult.-pass/t dem/field/dem by  
 '(the) Sepete who this field was cultivated by...'
- b. \*mwaáló {waa}- tupúnly - aáyá Hín-Sepété nth<sup>h</sup>ále ni  
 {aa} 'the knife that Sepete cuts bamboo with...'

The fact that Makua has prepositions rather than postpositions renders it inconsistent with most SOV languages.

Another relevant universal with respect to SOV and OSV orders is number 21:

"If some or all adverbs follow the adjective they modify, then the language is one in which the qualifying adjective follows the noun and the verb precedes its nominal object as the dominant order." (Greenberg 1972). Adverbs and qualifying adjectives do follow the adjectives they modify in Makua so that the dominant order in which the object follows the verb is argued for. Compare the examples in (40) below.

40. nipeéra ni-kíth<sup>h</sup>i ci-néné  
 guava ag-unripe very  
 'a very green guava'

Another characteristic of SOV and OSV languages is that such languages almost always have a case system (Universal 41). Here is another characteristic that Makua does not share with SOV and OSV languages.

Makua is, however, consistent with one of the implicational universals of SOV languages. Universal 5 says that "If a language has dominant SOV order and the genitive follows the governing noun, then the adjective likewise." The genitive does indeed follow the governing noun as in (41) and the adjective does likewise (42). Again, the order of these constituents is fixed.

41. a. múní wo mwáálo  
 handle gen. knife  
 'a handle of a knife'
- b. mwííla wo mwálapwa  
 'tail of a dog'
- c. níika no múúra  
 'string (out of hide) of a bow'
42. a. ikááve i-kíná  
 canoe ag-other  
 'another canoe'
- b. maapéera ma-kíth<sup>h</sup>i  
 guavas ag - unripe  
 'green guavas'

- c. kariróoré m-pyá  
 mirror ag-new  
 'a new mirror'

Thus, Makua shares few properties with either SOV or OSV languages and the one for which it does (Universal 5), it is not clear that only SOV languages have the order in which the genitive follows the governing noun.

Most of the rest of the relevant universals have to do with languages in which the dominant order is VSO. First, there is the matter of prepositions. Universal 3 claims that "Languages with dominant VSO order are always prepositional" (Greenberg (1972)). As was illustrated in the examples in (36-39) above, Makua has prepositions. However, the fact that Makua has prepositions and not postpositions does not argue in favor of VSO order but only against SOV order. Another universal relevant to the status of VSO languages is one which claims that languages with a basic VSO order have, as an alternative, SVO. Makua, of course, has both orders along with the other four possibilities.

Yet another universal which does not argue against a VSO order but, on the other hand, does not pick out that order is the one which claims that "in languages with dominant order VSO, an inflected auxiliary always precedes the main verb. In languages with dominant order SOV, an inflected auxiliary always follows the main verb." (Universal 16, Greenberg (1972)). It turns out that there is only one inflected auxiliary that I know of in Makua, and it always precedes the main verb. Compare the examples in (43) below. Again, Makua is inconsistent with SOV but consistent with VSO.

43. a. Hín-Sepété á-rii mu-úrwaani  
 Sepete sa - be in-to leave-in  
 'Sepete is (in the process of) leaving'
- b. \*Hín-Sepété mu-úrwaani á-rii



There are, however, two universals claiming properties consonant with basic VSO order which Makua does not share. Both are related to question formation. First, Universal 10: "Question particles or affixes, specified in position by reference to a particular word in the sentence, almost always follow that word. Such particles do not occur in languages with dominant order VSO." (Greenberg (1972)). In Makua there is in fact such a question particle, the suffix -ni. This suffix can be attached to a noun, or a verb indicating roughly 'which' or 'what'. Examples are given in (44).

44. a. aa - topóñre mwálapwa - ni ilák<sup>h</sup>ú  
 sa/t-chase/t dog -Q chicken  
 'which dog chased chickens?'
- b. aa - topóñre - ni mwálapw - ólé  
 sa/t-chase/t - Q dog -dem  
 'what did the/that dog chase?'

The presence of such a particle is not consistent with other known VSO languages. The second universal relating to VSO order and question formation is Universal 12: "If a language has dominant order VSO in declarative sentences, it always puts interrogative words or phrases first in interrogative word questions; if it has dominant order SOV in declarative sentences, there is never such an invariant rule" (Greenberg (1972)). The placement of question words in Makua is relatively free. Thus, in the examples in (45) below, one finds that the question word for 'who' (which is apani), when questioning a subject can appear in any of the orders in that example but one. I have no explanation for this gap. It is worth noting, however, that an applied object (45g) can precede the verb so the constraint in (45) is not a simple one, whatever its explanation.

45. a. SVO  
 apání aa-han - ílé nná-niváká - nná  
 who sa/t-forged-t dem-spear-dem  
 'who forged this spear'

- b. OVS  
 nná - niváká - nná aa-han-ílé apání  
 'this spear who was it who forged (it)?'
- c. SOV  
 \*apání nná-niváká-nná aa-han-ílé
- d. OSV  
 nná-niváká-nná apání aa-han-ílé  
 'this spear, who forged (it)?'
- e. VSO  
 aa-han-ílé apání nná-niváká-nná  
 'who was it who forged this spear?'
- f. VOS  
 aa-han-ílé nná-niváká-nná apání  
 'who was the one who forged this spear?'

Likewise, there is a question word for 'what' isiáni. In the examples in (46) below, the question word stands for an object and it too enjoys relative freedom. Again, there is a gap in the paradigm; however, I have no explanation for it.

46. a. SVO  
 Araárima aa-th<sup>h</sup>um-ílé isyááni  
 Araarima sa/t-buy - t what  
 'what was it that Araarima bought?'
- b. OVS  
 ?\*isyááni aa-thum-ílé Araárima
- c. SOV  
 Araárima isyááni aa-th<sup>h</sup>um-ílé  
 'What did Araarima buy?'
- d. OSV  
 ?\*isyááni Araárima aa-th<sup>h</sup>um-ílé
- e. VSO  
 aath<sup>h</sup>um-ílé Araárima isyááni  
 'It was Araarima who bought what?' (indicating more surprise than an echo question)
- f. VOS  
 aath<sup>h</sup>um-ílé isyááni Araárima  
 'Araarima was the one who bought what?' (indicating more surprise than an echo question)

These facts argue against VSO as the dominant order since the question words do not have a fixed position.

These are the relevant universals with respect to subjects, objects, verbs and other grammatical categories. As is often the case, the results are inconclusive. Makua is less consistent with SOV and OSV than any of the others. There are a couple of indications that it is inconsistent with VSO languages as well. That leaves SOV and VOS as possible alternatives. I am reluctant to conclude anything from the above discussion about syntactic basic word order because the results are inconsistent and because it is not clear that typology necessary has anything to do with the basic order as defined for the PSG under investigation.

#### 4.7 Comparative evidence

When in doubt about the basic order of a given language, it is tempting to turn to comparative evidence. That is, one checks to see what basic order is predominant for other languages in the family. This is a potentially invalid argument. Suppose that language X exhibits just two orders, SVO and SOV, but that the language exhibits only SOV characteristics, typologically speaking. Suppose, in addition, that all or nearly all languages in the family exhibit SOV typology but little or no SVO order. One might conclude that the language is SOV. Actually the most that can be said is that the language is consistent with SOV typology. It could be the case that the language is in the process of changing to a basic SOV order but that the change is incomplete. In fact, one might find that certain syntactic processes are better generalized to the SVO order. If that were the case then the typological order might turn out to be different from the syntactic basic order. The point is that the comparative evidence may give plausibility to

the choice, but that it, like the typological evidence, is not conclusive. In particular, it gives no real evidence for the choice of a syntactic basic order.

Regardless of the merits of such evidence, there are two relevant points to be made with respect to Makua. First, the status of word order in Bantu languages is unclear in general. As time goes on we have been uncovering more languages with free order properties similar to Makua, HiBena (Hodges, personal communication), Kimatumbi (Kisseberth and Odden, personal communication) as well as the other dialect of Makua, Ikorovere (Kisseberth, personal communication). On the West coast of Africa we find a limited amount of free word order as Watters (1979) has pointed out for Aghem, a Grassfields Bantu language. Other Bantu languages (e.g. Lingala, Swahili, and Tshiluba) have a fairly rigid order and it is SVO. And then there are sporadic cases like Runyoro, which, even though they have SVO order available, have a preferred SOV order in main clauses (Hodges, personal communication).

Aside from the fairly risky character of using such comparative evidence, it may be premature to make blanket statements about word order in Bantu languages.

## 5. Summary

In this chapter I undertook a discussion of the notion of basic word order as it related to the PSG under investigation. The discussion encompassed two rather general questions. First, it was shown how it would potentially be possible to separate out one order by appealing to subsets of rules which are defined by different properties. It was suggested that it would be possible to pick out those orders defined by basic rules (which are those rules not involving derived categories nor those rules enumerated

by the output of metarules). It remains to be seen if this division is a natural one in the syntactic analysis of a given language.

The other general question addressed in this chapter was, if one adopts a basic syntactic order, then what sorts of evidence count in picking out that order? There are of course the theory-internal arguments which will arise in the course of analysis. These will include the distinctions between orders specified by derived rules together with linking rules and those specified by metarules, for example. In addition to this syntactic sort of evidence, six other commonly appealed to criteria were discussed. Each was evaluated with respect to the definition of basic order defined in the present framework, although many of the questions raised could be applied to any syntactic definition of basic order. Then, each of the criteria was investigated with respect to Makua. The first of these, it was pointed out, had the most potential for the definition of a syntactic basic word order since it depended on the distinction between clause types, an essentially syntactic parameter. Nevertheless, Makua provided little evidence in this regard. The other criteria turned out to be even more inconclusive. With respect to marked vs. unmarked order, it was shown that it was difficult to decide between SVO (which was more likely to represent the normal state of affairs in the world, given the discourse function associated with that order), from the VOS order (which represented that most neutral order, the one with fewest presuppositions). Ambiguity, it turned out, did not provide anything conclusive either. This result came about because it is not clear exactly what one is testing out of context: the syntactic basic order, parsing strategies, or some discourse function. The typological correlations were also extremely indeterminate, suggesting only that SVO or VOS were likely candidates. Finally, text frequency counts and comparative evidence were argued against on independent grounds.

In addition to the general indeterminacy of the results, it was pointed out that the use of the above evidence for choosing a basic syntactic order rested on the assumption that the unmarked order ought to be the same as the typological order, which ought to be the same as the syntactic basic order. Insofar as there are other parameters which may not be, strictly speaking, syntactic (e.g. discourse function), then this remains just an assumption. As Geoff Pullum (personal communication) has pointed out, the absence of this assumption leads one to expect to find a language in which the typological order is VSO, for example, the unmarked order is SOV, the syntactic basic order is SVO, etc. Such a situation seems highly unlikely, to say the least. I can only conclude that a lot of work needs to be done in the formal specification of basic order.

It seems reasonable then to go about the business of investigating a basic syntactic order for Makua, and for the most part, I will try to rely on theory-internal evidence as support for the choice. But, one has to start somewhere. In this grammar, in order to provide for well-formed sentences, one has to start with some order. I have chosen SVO.

## NOTES

<sup>1</sup>McCawley (1968) notes that if one utilizes phrase structure rules under the rewrite interpretation, it can be the case that a derivation may not be sufficiently precise to insure that a single tree corresponds to just one derivation. He suggests that this indeterminacy can be obviated if the base component operates directly in terms of trees without an intermediate state of rewrite rules. Accordingly, he proposes that the base consists of node admissibility conditions. For a rule of the sort  $A; BC$ , a node labelled A is admitted if it dominates a node labelled B and a node labelled C. (McCawley 1968:247). Gazdar has adopted a different notation,  $[_A BC]$  rather than  $A; BC$ .

<sup>2</sup>One way in which Gazdar's semantics differs from Montague's (1973) PTQ treatment is that Gazdar takes VPs as denoting functions from NP intensions to truth values, rather than a translation in which the NP is taken to be a function with a VP as its argument. As Gazdar points out, the former treatment is in line with Montague's (1970) earlier treatment, and, in addition, has strong motivation on other grounds (see Gazdar (to appear b: 16) and references there).

<sup>3</sup>See Grinder and Elgin (1973) for example, where it is argued that the process of Particle Movement cannot be formulated within a CF PSG at all and only inelegantly within a CS PSG. Gazdar (to appear b) does provide a motivated and elegant treatment of this process within a CF PSG.

<sup>4</sup>Gazdar (1980:40) points out that such devices have precedents not only in programming languages (see Cleaveland and Uzgalis 1975) but in linguistics as well, e.g. Vergnaud's (1973) "lexical transformations" which were further developed by Roeper and Siegel (1978).

<sup>5</sup>One comment about the use of variables is in order. To quote Gazdar (to appear b: 43-44),

"We require that metarules be finitely specifiable. The only variables permitted in the structural analysis (to borrow the transformational terminology in an obvious manner) are abbreviatory ones, that is variables which range over a finite subset of  $(V_N \cup V_T)$ . Adherence to this requirement ensures that closing the grammar under some set of metarules will not result in an infinite set of rules being produced." Gazdar further points out (in Footnote 27 (to appear b) that Joshi (personal communication) has called to his attention the fact that "allowing a single non-abbreviatory variable in the structural analysis of metarules would open the way to PS grammars with infinite sets of rules, but would not result in any of those grammars inducing non-context free languages. Non-context-free languages can only result when two or more non-abbreviatory variables are permitted." The upshot of all this is that certain formulations of metarules are disallowed if the restriction of generating only context-free languages is adhered to.

<sup>6</sup>While the introduction of categories with gaps and the attendant derived rule schema are new devices within linguistic theory, Joshi and Levi (1980) point out that categories with gaps have been used in parsers (at least Sager (1967)) and they suggest, probably others.

<sup>7</sup>Language specificity can arise at four places in the grammar as defined so far.

- 1) The set of basic rules ( $R_G$ )
- 2) the subset of nonterminal categories ( $V_N$ ), which participate in derived rules
- 3) the nature of the linking rules
- 4) language particular constraints on the set of derived rules

<sup>8</sup>Schmerling (1971), for example, has argued that an assumption or "normal" stress obscures the real generalizations which underlie the use of English stress, which, she argues to be associated with presuppositions of various sorts. The assumption of the existence of a normal pattern could then be maintained only by claiming that some presuppositions are more normal than others.

<sup>9</sup>One claim that is made about the frequency of a particular order, is that a child learning the language will hear a particular order more often, and hence, generalize that order as basic. This would work as an argument only if children in fact use frequency in generalizing structure. One place to look for such evidence would be in the acquisition of free word order languages by children. Unfortunately, there is little evidence on this literature on this topic. One study noted by Bach (1975) showed that Russian children learning the language had a fairly inflexible order and that this order did not always correspond to what is taken to be the dominant order (in a study by Gvozdev cited by Slobin 1966: 133-35). It is difficult to draw any conclusions from this evidence with regard to frequency, since it is not known whether those children were exposed to different frequencies of order. Again, the question would arise, how frequent is frequent enough?

<sup>10</sup>The morpheme wa as used here is not part of a genitive phrase of the form NP ag-gen NP but rather simply wa NP. This morpheme is the only morpheme of the sort I am aware of. In fact, I don't even know if vowel coalescence occurs between wa and the subsequent NP. Conceivably, if it was analyzed synchronically as the locative prefix u - a there would be other forms with the other two locative prefixes va- and mu-. Such forms do not exist. Nor is the meaning of wa mwaarimu 'to the teacher' locative in the sense of 'to the teacher's place' as might be expected if the literal interpretation of uta is taken.

<sup>11</sup>The morpheme ni also appears in suffix position marking a locative noun. This is a feature of Eastern Bantu languages, notably Swahili. However, in this position, it seems unlikely that it should be considered to be a postposition since an additional locative prefix is required to give any prepositional notion of location. What the suffix -ni seems to



be doing here is marking the noun simply as a locative noun, while the locative prefix serves to indicate what kind of location, in, at, or on, is indicated. Thus, it is questionable whether this use of ni should be called postpositional.

## CHAPTER IV

## A FRAGMENT OF THE SYNTAX OF MAKUA MAIN AND COMPLEMENT CLAUSE TYPES

## 1. Introduction

In this chapter, rules accounting for a relatively large subset of Makua main and complement clause types are introduced. The fragment under discussion in this section includes the analysis of word order in clauses consisting of 1) a subject NP and an intransitive verb, 2) a subject NP, an object NP, and a transitive verb, and 3) a subject NP, two object NPs, and a derived bitransitive verb. In addition to the above sentence types, four kinds of complement structures are included in the analysis. Evidence from the syntactic distribution of both verb phrase adverbs and sentence adverbs is brought to bear on the analysis of word order, although the analysis of adverbs is incomplete. A complete list of all the rules introduced in this chapter can be found in Appendix B.

The analysis of word order involves the use of three rule types as defined in Chapter III. First, there are rules establishing a basic syntactic order. Second, derived rules and linking rules accounting both for unbounded dependencies and, to some extent, word order, are motivated. Finally, metarules generalizing over subsets of rules establish the rest of the orders.

The central problem, of course, is deciding which of the above rule types should be used to characterize which orders. The arguments for choosing a particular rule or type of rule follow, in part, the criteria outlined in the previous chapter. There it was argued that the rules establishing

a basic order should be justified primarily by finding those syntactic interactions internal to the language which can be stated more generally in terms of one order rather than another. The results of the analysis for Makua actually turn out not to be decisive in this regard. It is not possible to determine on the basis of the data considered exactly which of the orders is basic (although it is fairly easy to show that some basic order is desirable). The implications of this finding are set out in the final chapter of the thesis.

In addition to choosing a basic syntactic order there is the problem of deciding which syntactic interactions ought to be characterized by the use of linking rules and derived rules and which ought to be characterized by metarules. In the preceding chapter several sorts of generalizations these types of rules can make were outlined. First, it was observed that derived rules necessarily have the same syntactic features as the rules they were derived from. Metarules, on the other hand, automatically carry over any syntactic features from the input to the output unless a feature (or features) is explicitly changed. Thus, the output of a metarule may differ from the input in this regard, while a derived rule may not differ from the rule it is derived from. Both the rules generalized over by the output of a metarule and any derived rules will have the same subcategorization properties as the basic rules they are related to. This result is assured for the metarules because the rule number of the rules generalized over by the input remain the same. The derived rules have this property because the derived rule schema allows no changes in the order or number of constituents in the rules so derived. In addition, derived rules have the same rule number as the rule they are related to, so that all facts regarding verb government are predicted to be the same.

One further difference between derived rules and metarules not explicitly discussed in the preceding chapter is the difference in predictions with respect to unbounded dependencies. The derived rule categories and derived rule schema were set up explicitly to capture unbounded dependencies. It turns out that the use of these formal devices together with linking rules predicts a resulting interaction of rules capturing unbounded dependencies. Metarules, on the other hand, are not equipped to make general statements about unbounded dependencies. Why this is so is discussed in some detail in the second section of this chapter. Taken together, this last difference between metarules and derived rules with the criteria just outlined, form the basis of argumentation on which different rules and different rule types are motivated.

A crucial aspect of this analysis is that it does not rely on any single device such as a scrambling rule (like that in Ross (1967)) or simple concatenation rules of the sort proposed recently by Hale (1979) or Lapointe (1981) (all proposals for free word order languages). A comparison of these three approaches with the analysis proposed here is taken up at the end of the chapter.

This chapter is organized as follows. The second section outlines the different predictions made by the formal devices embodying derived rules and metarules with respect to unbounded dependencies. Section 3 contains the analysis of Makua word order proper. The final section (Section 4) contains a summary of the analysis and the implications of that analysis for the definition of basic order provided within the present framework as well as for the comparison of this analysis to other analyses that have been suggested for free word order languages.

## 2. Empirical predictions made by the use of derived rules and metarules

Before discussing what empirical predictions fall out from the use of derived rules versus metarules, it is perhaps worthwhile to point out the sort of problem raised by a word-order analysis which depends on the distinctions in predictions. Suppose one has the order SVO in a given language and that one chooses to write a basic rule (as in (1) below) which will, in conjunction with other necessary rules, provide for that order.

$$1. \langle n \text{ } [_{\text{S}} \text{ NP VP } ] \dots \rangle$$

Suppose in addition, that there is an alternative order VOS. Among the myriad choices one has for getting this second order are the following two. One can either write a linking rule as in (2a) below which will, together with derived rules, get the order VOS, or one can write a metarule of the sort in (2b) which has the same end results for word order.

$$2. \text{ a. } \langle n, [_{\text{S}} \text{ S/NP NP}] \dots \rangle$$

$$\text{ b. } \langle n, [_{\text{S}} \text{ NP X}] \dots \rangle \implies \langle n, [_{\text{S}} \text{ X NP}] \dots \rangle$$

The first rule (2a), but not the second (2b), will predict that NPs may be found an indefinite number of clauses away from the ones they belong to semantically, i.e. it predicts unbounded dependencies for subject NPs.<sup>1</sup> The discussion in the following subsection will show why this is so. In addition to this prediction, the formal apparatus also makes a subtle difference in predictions about the likelihood of resumptive pronouns or traces. This prediction is discussed in the subsequent subsection (2.2).

### 2.1 Unbounded dependencies - derived rules versus metarules

Even though the formalism was set up initially so that the derived categories and derived rules provided a natural account of unbounded dependencies, while metarules were added to the framework to provide different

sorts of generalizations, it is important to understand why it is that two devices differ with respect to unbounded dependencies in the way that they do. I will discuss each of the two devices separately first.

Strictly speaking, it is not just the use of derived categories and derived rules which accounts for unbounded dependencies. Rather, it is the way in which these devices interact with linking rules which accounts for (and predicts) unbounded dependencies.

Suppose by way of example, that a grammar contains only the basic rules in (3).

3. a.  $\langle 1, [{}_S \text{ NP VP}] \dots \rangle$
- b.  $\langle 2, [{}_{VP} \text{ V NP}] \dots \rangle$

Suppose, in addition, that at least the derived categories  $\alpha/\text{NP}$  are admitted. (where  $\alpha$  is any non-terminal category in the grammar for that particular language). The derived rule schema together with the derived categories and the basic rules in (3) above, will predict all and only the derived rules in (4).

4. a.  $[{}_S/\text{NP} \text{ NP}/\text{NP} \text{ VP}]$
- b.  $[{}_S/\text{NP} \text{ NP} \text{ VP}/\text{NP}]$
- c.  $[{}_{VP}/\text{NP} \text{ V} \text{ NP}/\text{NP}]$

No derived rules like that in (5) below will be admitted because the derived rule schema insures that the category with a gap in it will be paired with a category admitting the same gap in each rule.

5. a.  $[{}_{VP} \text{ V} \text{ NP}/\text{NP}]$
- b.  $[{}_{VP}/\text{NP} \text{ V} \text{ NP}]$

Thus, the partial grammar here will analyze a partial tree like that in

(6a) below. It will not analyze a partial tree like that in (6b) (unless one writes an independent CSR  $[_{VP} V NP/NP]$ , but this will be, by definition, not a derived rule).

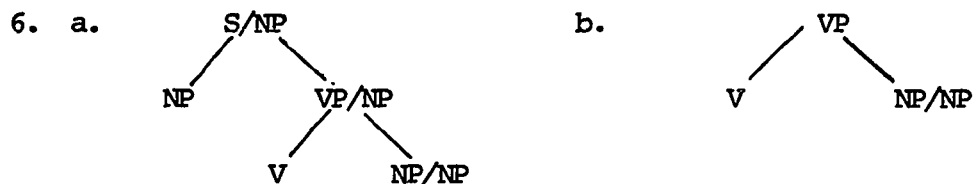

A partial tree like that in (6a) above will never be analyzed as a well-formed sentence because it is rooted in S/NP (and not S, the symbol on which well-formedness is defined) and because it does not terminate in terminal symbols. If, however, a linking rule of the sort in (7a) below, which admits an S node just in case it dominates NP and S/NP is added, then (terminal symbols aside) either of the two trees in (7b) and (7c) will be analyzed.

7. a.  $[_S NP S/NP]$

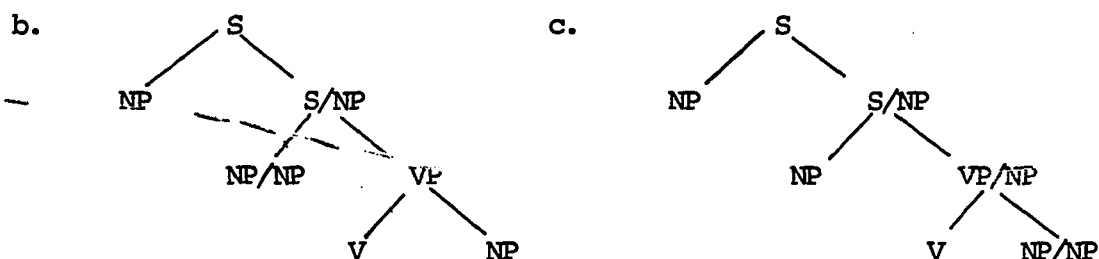

So far, there is nothing in this example grammar which predicts unbounded dependencies, however. But, suppose the rules in (8) are added.

8. a.  $[_S \bar{S} COMP S]$

b.  $[_{VP} V NP \bar{S}]$

The addition of these rules will, together with the derived rules and the basic rules in (3) predict structures like those in (9a) and (9b) below. In (9a) the NP at the head of the sentence is correlated to a gap in the embedded sentence. In (9b) an NP is found at the head of the embedded sen-

tence and it is correlated with a gap in that embedded sentence. There is in the case of (9a) at least, an unbounded dependency.

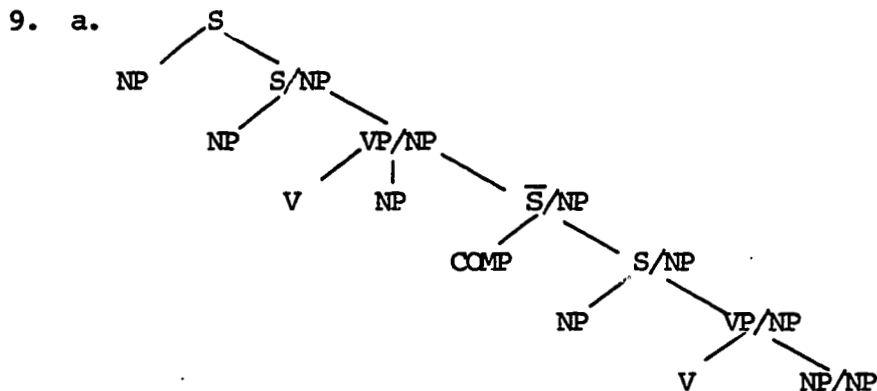

b.

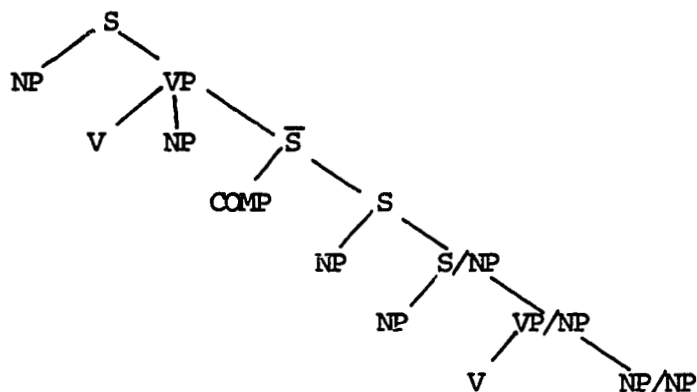

Thus, anytime a derived rule together with a linking rule admitting the same slashed category interact with rules introducing complements, the grammar predicts that unbounded dependencies should occur. To prevent the interaction of unbounded dependencies like that in (9b) will be costly, i.e. require the addition of a constraint.

One can restrict the number and kind of derived categories ( $\alpha/\beta$ ) admitted in a particular grammar by stipulating what  $\alpha$  and  $\beta$  are allowed to be, i.e.  $\alpha \neq \bar{S}$ . In this way, no category  $\bar{S}/NP$  would be allowed. A tree like that in (9a) would then not be analyzed by the grammar. Alternatively, one could place a restriction on which rules the derived schema applies to so that



the rule  $[\bar{S}/NP \text{ COMP } S/NP]$  is not admitted to the grammar, thus ruling out (9b). The choice between these two alternatives is dependent on language specific considerations. Restricting the derived categories will allow extraction of no category out of a sentential complement. Restricting the derived rule schema will allow categories other than NP to be extracted out of sentential complements.

Metarules, on the other hand, are not equipped to make generalizations about unbounded dependencies.<sup>2</sup> An example should show why this is so. Suppose one wishes to account for the relatedness of structures like those in (9a) and (9b) above, by means of a metarule. One might begin with a metarule like that in (10) which states that verb phrases with a verb and an NP are related to sentences with an NP at the beginning of the sentence. This metarule will predict the existence of rules like those in (10b) and (10c).

10. a.  $[\bar{VP} \text{ V } NP_i \text{ X}] \Rightarrow [S \text{ NP}_i \text{ NP V X}]$   
 b.  $[S \text{ NP VP V}]$   
 c.  $[S \text{ NP NP V } \bar{S}]$

The rules in (3), (8b) and (10) in this sample grammar will admit S nodes with the following two structures.

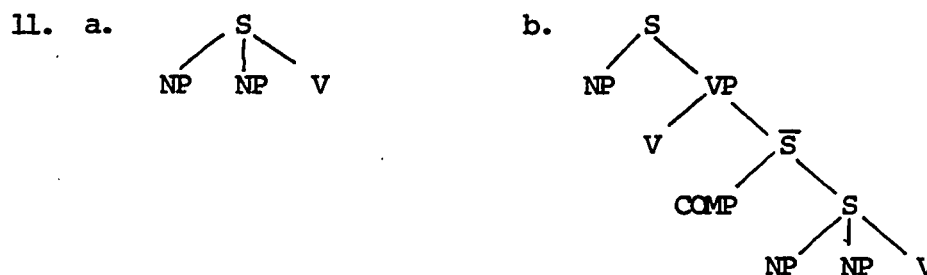

These two structures analyze the same order of constituents as in (7c) and (9b) above, NP NP V and NP V comp NP NP V.

There is no way, however, to provide for structures in which an NP semantically belonging to one clause is found in a higher clause using metarules of the sort just outlined. They account only for clause-bounded phenomena.

The point is that derived rules together with linking rules do provide for a natural account of unbounded dependencies. This difference in predictions between metarules and derived and linking rules has been employed in the analysis of Makua word order for making a choice between possible accounts of the different word orders.

## 2.2 Resumptive pronouns, traces, etc.

Along with the difference in respect to boundedness just described, the choice of a derived rule or a metarule has consequences for certain types of morphology related to the interaction of rules. Because the slashed categories are not themselves terminal symbols, linking rules to allow for their elimination are needed. As pointed out in Section 3.3 of the preceding chapter, these linking rules could terminate in either a resumptive pronoun, a trace or the empty node. Since the framework requires that such rules exist, it is not costly to leave a resumptive pronoun or some trace in a gap. The appearance of such terminal elements as traces or resumptive pronouns is a natural consequence of the formalism (i.e. the slashed categories) itself.

Metarules, on the other hand, have no such natural realization of traces or resumptive pronouns, although it is technically possible to work those in. Take, for example, the rule proposed in (10a) above. This rule could have been formulated as follows.

$$12. \quad [{}_{VP} V NP_i X] \Rightarrow [{}_S NP_i NP V X \text{ pro}]$$

Along with some agreement features for the resumptive pronoun and its related NP, one could achieve the desired effect. The appearance of the resumptive pronoun, however, is not a natural outcome of the formalism in the way it is with the use of the derived categories. In addition, the use of a linking rule which terminates a NP/NP (or any other slashed category) will make predictions about certain classes of rules (e.g. all derived rule interactions) while the leaving of a resumptive pronoun in the output of a metarule will not generalize to any other structures than the ones enumerated by that metarule itself.

### 2.3 Summary

In addition to the differences in kinds of generalizations that the use of derived rules and metarules make, which were noted first in the preceding chapter and summarized in the introduction to this chapter, two additional differences have emerged. Derived rules together with linking rules allow for a general and natural account of unbounded phenomena. Metarules do not allow for any generality of description in such cases. Derived rules together with linking rules naturally leave traces or resumptive pronouns. Metarules do not.

### 3. The analysis of word order in Makua

The organization of this section is as follows. The first subsection lays out rules (minus the semantics, for the most part) which account for the basic order of a subset of Makua declarative clauses. While some motivation is given for the rules, much of that must wait until the analysis progresses. The second subsection includes a discussion of unbounded dependencies. The final subsection introduces the metarules.

### 3.1 The basic rules.

The analysis in this and the two subsequent sections is designed primarily to account for word order variation. Hence, many details are left unspecified. Verb agreement, for example, is not dealt with here but in Chapter V where this analysis is extended. Details of phrase structure such as that of the NP are likewise left unspecified (but see Chapter VI where some treatment of the NP is given in conjunction with relative clauses). An important omission is the treatment of sentences in which no overt subject NP is found, no overt object or both. In these cases (discussed previously in Chapter II, Section 2.3) verb agreement is still obligatory, taking on an essentially anaphoric function. I am undecided about the analysis of the syntax or semantics of such sentences in Makua, so that I will not treat them here. In general, the data in which full NPs appear is more revealing about the word order freedom in any case, so that this omission is probably not crucial. Many of the rules are incomplete in that they lack the semantic translations. Only where the semantics are crucial are they included. These omissions have been made in the interest of simplifying the presentation and it is hoped that they do not obscure any relevant observations.

As a starting point, take an elementary Makua sentence consisting of just a subject and a verb, in that order, sentences such as those in (13) below can be accounted for (in part) by the rules in (14).

13. a. ásuúlúpaály-áále a-ho-rúp-á  
 old man -dem sa/t-sleep-t  
 'the old man is asleep/has (already) slept'
- b. ikárikó i-ho-pwá-á  
 sm. cooking pot sa-t-break-t  
 'a small cooking pot is broken/has broken'

14. a.  $\langle 1, [{}_S \text{ NP VP}], \text{VP}'(\text{NP}') \rangle$   
 b.  $\langle 2, [{}_{\text{VP}} \text{ V }], \text{V}' \rangle$

Verbs in Makua can be transitive as well, in which case an object NP is allowed. Adding the rule in (15) below will account for SVO order in an example like that in (16).

15.  $\langle 3, [{}_{\text{VP}} \text{ V NP}], \text{V}'(\text{NP}') \rangle$   
 16.  $\acute{n}t^h\acute{u}$   $\beta$ -ho-t<sup>h</sup>ékúl - a ikáríko  
 person sa-t-tip over-t sm. cooking pot  
 'some person has tipped over a small cooking pot'

Both of the above rules make use of a verb phrase but no evidence is provided at this point for its existence in Makua. That will emerge as the analysis progresses.

I now turn to a set of more complicated constructions. In Chapter II, mention was made of a set of derivational suffixes, many of which affect the transitivity of the verb in question. Just two of those suffixes are discussed in this analysis, the causative (-ih-), and the applied (-el-~ -er-). The effect of these suffixes is to increase the valency of the verb by one. Thus, a basically intransitive verb when marked by the applied or causative suffix can be accompanied by an additional NP argument. Transitive verbs likewise can have an additional NP, i.e. they become bitransitive. For a verb marked by the causative, the "extra" NP will have as its meaning that of a causee. Examples of a basically intransitive verb and a basically transitive verb with the causative suffix are given in the examples in (17).

17. a. ásuúlúpaály - áálé áhó-n-rúp - ih - á mwaán-ólé  
 old man - dem sa/t-oa-sleep-caus-t child-dem  
 'the old man caused the/that child to sleep'

- b.  $\acute{n}t^h\acute{u}$   $\beta\text{-}\acute{a}h\acute{o}$  -  $\acute{n}\text{-}t^h\acute{e}k\acute{u}l\text{-}i\acute{h}\text{-}\acute{a}$   $mwa\acute{a}n\text{-}\acute{o}l\acute{e}$   $ik\acute{a}r\acute{i}k\acute{o}$   
 person sa-t-oa-break-caus-t child-dem sm. cooking pot  
 'some person caused the/that child to break a cooking pot'

The thematic relation of the "extra" NP admitted by verbs marked with the applied suffix is more complicated. There are at least four possibilities. The extra object can be a locative, an instrument, a recipient, or a beneficiary. As a cover term, I will refer to these NPs as applied objects. Their use is illustrated in the examples in (18) below. The first of each pair includes a derived transitive verb, the second, a derived bitransitive verb.

#### 18. Beneficiary

- a.  $mwa\acute{a}n\text{-}\acute{o}l\acute{e}$   $\acute{a}h\acute{e}e\acute{n}\text{-}\acute{e}l\text{-}a$   $\acute{a}su\acute{u}l\acute{u}pa\acute{a}ly\text{-}\acute{a}\acute{a}l\acute{e}$   
 child-dem sa/t/oa-dance-app-t old man-dem  
 'the/that child danced for the old man'
- b.  $mwa\acute{a}n\text{-}\acute{o}l\acute{e}$   $\beta\text{-}h\acute{o}\text{-}l\acute{i}m\text{-}\acute{e}l\acute{a}$   $\acute{a}su\acute{u}l\acute{u}pa\acute{a}ly\text{-}\acute{a}\acute{a}l\acute{e}$   $im\acute{a}t\acute{a}$   
 child-dem sa-t-cult-app.-t old man-dem grainfield  
 'the/that child has cultivated a grain field for the/that old man'

#### Recipient

- c. (I have no example with a basically intransitive verb.)
- d.  $\acute{a}su\acute{u}l\acute{u}pa\acute{a}ly\text{-}\acute{a}\acute{a}l\acute{e}$   $\acute{a}h\acute{o}\text{-}\acute{n}\text{-}t\acute{a}ng\text{-}\acute{e}l\text{-}\acute{a}$   $mwa\acute{a}n\text{-}\acute{o}l\acute{e}$   
 old man-dem sa/t-oa-tell-app-t child-dem  
 $ind\acute{a}ngw\text{-}aaya$   
 story-poss  
 'the/that old man told his story to the/that child'

#### Locative

- e.  $H\acute{i}n\text{-}Sep\acute{e}t\acute{e}$   $\acute{a}h\acute{o}\text{-}r\acute{u}p\text{-}\acute{e}l\text{-}a$   $mpw\acute{a}r\acute{o}\text{-}ni$   
 Sepete sa/t-sleep-app-t loc-men's meeting place-loc  
 'Sepete slept at the men's meeting place'
- f.  $H\acute{i}n\text{-}Sep\acute{e}t\acute{e}$   $\acute{a}h\acute{e}e\acute{t}\text{-}\acute{e}l\text{-}a$   $m\text{-}mwa\acute{a}p\acute{u}\text{-}ni$   $nr\acute{u}su$   
 Sepete sa/t/pour-app-t loc-pot-loc brew  
 'Sepete poured brew into the pot'

#### Instrumental

- g.  $H\acute{i}n\text{-}Sep\acute{e}t\acute{e}$   $a\text{-}n\acute{o}\acute{o}\text{-}l\acute{u}p\acute{a}t^h\text{-}\acute{e}l\text{-}\acute{a}$   $\acute{a}k\acute{a}p\acute{u}t^h\acute{i}$   
 Sepete sa-t-shoot-app-t guns  
 'Sepete uses guns to shoot'

- h. Hín-Sepété áhó-lúl-él-a ufúngúwo nlák-ólé  
 Sepete sa/t-open-app-t key door-dem  
 'Sepete used a key to open the door'

One fact that has to be accounted for in the syntax of Makua is that each verb phrase containing a derived verb has one more argument than its non-derived counterpart. It is, in principle, possible to have complex derived verbs with more than one derivational suffix, so that the number of arguments that may in fact be unlimited. I will return to this point shortly. At present I do not have enough facts for a full analysis of such structures in Makua. I will, therefore adopt only a version of one that I think is compatible with the facts as I know them in Makua, taking into account what I know about such structures in other Bantu languages.

Several possible accounts of these bitransitive verbs are available within this framework. The first question to be resolved is whether one wants to write a single VP rule admitting a VP node when it immediately dominates two NPs as in (19) below, or whether one wants to write a multitude of rules separating out the applied from the causative as well as the various uses of the applied, e.g. recipient, beneficiary, instrumental and locative as in (20).

19. [<sub>VP</sub> V NP NP]

20. a. < 4, [<sub>VP</sub> V NP NP]... >  
 [+caus]

b. < 5, [<sub>VP</sub> V NP NP]... >  
 [+app]  
 [+ben]

c. < 6, [<sub>VP</sub> V NP NP]... >  
 [+app]  
 [+loc]

- d. < 7, [<sub>VP</sub> V NP NP],... >  
       [+app]  
       [+rec]
- e. < 8, [<sub>VP</sub> V NP NP],... >  
       [+app]  
       [+inst ]

Two sorts of evidence can be brought to bear on the choice between writing a single rule (as in (19)) or a multiplicity of rules as in (20). I will refer to these choices as the single rule approach and the multi-rule approach. The first sort of evidence that would be relevant is semantic. Since each syntactic rule is accompanied by a semantic translation, then, if a distinct translation is wanted for the causee vs. the instrument versus the beneficiary, then the multi-rule approach is to be preferred. Otherwise it will not be possible to pick out separate meanings from the single rule since there is a single semantic translation for all. If such a sophisticated translation is ultimately desirable then the multi-rule approach is to be preferred.<sup>3</sup> My own inclination is that one wants to leave open this possibility, however I will not pursue this any further. The second sort of evidence is essentially syntactic. If one finds, for example, that any of the different uses of the applied or the causative are distinct from each other syntactically, then this evidence would argue for the multi-rule approach since the single rule approach would not allow one usage to be picked out for special treatment. There is in Makua (as in many Bantu languages) evidence of just this sort, distinct syntactic behavior on the part of two uses of the applied verbs.

A sentence with an instrument NP and an applied verb is related to a structure in which the verb is not marked by the applied and the instrument is preceded by the prefix *ni-* 'with'. (Compare the example in (18g) with the



example in (21) below). If this relationship is to be expressed syntactically, then the second of the two approaches is argued for since it will allow just the instrumental use of the applied to be picked out. Thus, at least the rules in (21) below will be needed to introduce these instrument phrases. I have chosen to treat the ni- as a feature on the PP node since its role is largely semantic analogous to case marking (See Gazdar (to appear b) for a similar treatment of to and for phrases in English).

21. a. Hín-Sepété áhó-lúl-á nlák-ólé níufunguwo  
 Sepete sa/t-open-t door-dem with/key  
 'Sepete opened the door with a key'

b. < 9, [PP ni-NP]... >  
 [+inst]

c. < 10, [VP V NP PP ]... >  
 [+inst] [+inst ]

Then the prepositional instrument and the nonprepositional instrument can be related by means of the following metarule. This rule will generalize over all VP rules in which [+inst] PPs appear.

22. < n, [VP V NP<sub>i</sub> PP X ]... >  $\implies$   
 [-app] [+inst ]  
 < n, [VP V NP<sub>i</sub> NP X] ... >  
 [+app]  
 [+inst ]

The beneficiary use of the applied, in contrast, has no parallel structure in which the beneficiary NP appears in a prepositional phrase. By distinguishing the various uses of the applied, i.e. by writing many separate rules, the difference between the instrumentals and beneficiaries can be accounted for. It could of course be argued that such a relationship ought to be semantic rather than syntactic, but this generalization would still

require separate rules. Such differences are not restricted to the applied. Related structures also exist for causatives but I will not go into details here because I have not worked out the full analysis of causatives.

In addition, the behavior of the VP adverbs (to be discussed in section 3.3 of this chapter) and the treatment of agreement (in Chapter Five) argue in favor of this second multi-rule approach.

I will propose then, that there are at least the rules in (20) above. There are some important details left out, however. The features used to distinguish applied from causatives are on the VP node but it is the verb itself which has this marking. Here I will make an appeal to what is termed the Head Feature Convention (see Gazdar (to appear b) for motivation), a formalization which insures that any feature on the phrase also appears on the head of that phrase. This convention is discussed in more detail in Chapter V so I will not present the details at this point. This convention will insure that the verb node itself has the features.

The analysis just proposed for bitransitive verbs is lacking in another respect. As it stands, there are transitive verb phrases without any specification that some of these contain applied or causative verbs, while there are no bitransitive verb phrases which do not have these derived verbs. Should one want to make a syntactic generalization that applied transitive verb phrases are related to intransitive verb phrases and that in the same fashion transitive verb phrases are related to applied bitransitive verb phrases, then the following set of metarules can be added to the grammar.

23. a.  $\langle n, \begin{matrix} [_{VP} & V X] \\ [-caus] \end{matrix}, \dots \rangle \implies \langle n, \begin{matrix} [_{VP} & V NP X] \\ [+caus] \end{matrix}, \dots \rangle$

- b.  $\langle n, [\text{VP } V \text{ X}] \dots \rangle \Rightarrow \langle n, [\text{VP } V \text{ NP } X] \dots \rangle$   
 $[-\text{app}, -\text{ben}] \quad \quad \quad [+ \text{app}, + \text{ben}]$
- c.  $\langle n, [\text{VP } V \text{ X}] \dots \rangle \Rightarrow \langle n, [\text{VP } V \text{ NP } X] \dots \rangle$   
 $[-\text{app}, -\text{rec}] \quad \quad \quad [+ \text{app}, + \text{rec}]$
- d.  $\langle n, [\text{VP } V \text{ X}] \dots \rangle \Rightarrow \langle n, [\text{VP } V \text{ NP } X] \dots \rangle$   
 $[-\text{app}, -\text{loc}] \quad \quad \quad [+ \text{app}, + \text{loc}]$

It could of course be argued that this generalization is not essentially syntactic but is either semantic or lexical in nature. However, the above metarules make some additional claims which seem correct. First, they simplify the analysis of verb agreement to come, and they make correct predictions about VP adverbs, evidence which is presented in section 3.3 of this chapter. It does make a claim about the syntactic relatedness of basically intransitive and transitive verbs to their derived transitive and bitransitive counterparts. One implication of this interaction is that the meta-rule relating prepositional instruments to their non-prepositional instruments is now general enough to relate the prepositional phrases to their non-prepositional counterparts regardless of the transitivity of the verb; the rules as previously stated did not relate basically intransitive verbs to transitive applied instrumental verbs.

Two potential problems arise with the introduction of the metarules in (23). First, the bitransitive verb phrases no longer are part of the basic word order as defined in Chapter III because they are enumerated by the output of a metarule rather than the input. This result could be indicative of a faulty analysis if it is determined that these bitransitive structures ought to be part of the basic order, or it could be that the notion basic order is ill-formulated or else inappropriate in this framework.

Another potential problem is that this analysis does not allow for double

causatives or double applieds. Both such patterns are attested in other Bantu languages, but to date I have not uncovered any such verbs that do not seem to be a frozen form plus a productive use of the applied. Secondly, this approach predicts that if a verb had both an applied suffix and a causative suffix then the verb phrase could contain three NPs, since the metarules adding NPs do not prevent an applied verb from becoming causative. I have very little data on such constructions. Whenever I constructed such examples, Wembah either rejected them outright or provided some other translation. Thus, compare the examples in (24) below. In (24a) there is both an applied suffix and a causative. The consultant's reaction was that it was all right as long as the first NP was not incorporated as the causee but that such a sentence would not be used. Rather (24b) is the more likely construction. If examples like that in (24b) turn out to be productive after all then some variation of the approach not employing metarules might be preferred since the upper bound on NPs is made explicit. Alternatively, the second approach could be expanded to treat verbs carrying [+caus,+app] differently from [+caus,-app] or [-caus,+app], for example.

Regardless of how the whole thing works out in the end, someplace in the grammar of Makua there will have to be rules of the form [<sub>VP</sub> V NP NP] together with the appropriate features, whether there is a metarule or not.

24. a. míí káháá-túpul-ih-ér-á Araárima nkácu  
 I sa/t/oa-cut caus-app-oa Araarima cashew nut tree  
 'I caused s.o. to cut down a cashew nut tree for Araarima'  
 (not: I caused A. to cut down a tree for someone)
- b. míí káháá-rúma waátúpul-él-á Araárima nkácu  
 I sa/t/oa-ask-t to cut-app-a Araarima cashew nut tree  
 'I asked s.o. to cut down a cashew nut tree for A.'

I now turn to verb plus complement constructions in Makua. Only a representative sample is treated, those that I am most familiar with. These constructions are crucial to the analysis of word order because it is here that some constraints on order are found. Each kind of complement will be introduced by representative examples and a rule accounting for those examples. The semantics play a crucial role in the treatment of complementizers so I will try to give an intuitive account whenever possible for readers not familiar with formal semantics.

The first class of constructions to be treated are sentential complements. In Makua, there are three complementizers that I know of, éti, thókó, and wiirá, all of which can be loosely translated as 'that'. Each of these complementizers can introduce only full sentences, although the choice of complementizer does not depend on the syntax of the complement sentence itself. Rather, the choice of complementizer depends on a complicated interaction between the lexical meaning of the verb, the tense and aspect of the matrix verb, as well as the tense and aspect of the embedded verb, and the beliefs of the speaker with respect to the truth of the complement. Éti, for example, signals that the speaker is not committed to the truth of the complement. Wiirá indicates that the speaker is certain of his belief in the truth of the complement, while thókó seems to be somewhere in between. The effect of this sort of interaction is that some verbs, i.e. ucúwéla 'to know' can only have wiirá as a complementizer (presumably because the lexical meaning of 'know' commits the speaker to belief in the truth of the complement). Wiíriha 'to think' can have any of the complementizers signalling varying degrees of assertion of belief. Representative examples are included in the examples in (25).

25. a.  $\begin{matrix} \text{amuna} & \text{aho-cu} & \text{wela} \\ \text{at-w-} & \text{aaya} & \text{aho-rwa-a} \\ \text{wira} & & \end{matrix} \left\{ \begin{matrix} *eti \\ *thoko \end{matrix} \right\} \begin{matrix} \text{wira} \\ \text{wife-poss} \\ \text{sa/t-go-t} \end{matrix}$  my brother sa/t-know that  
 'my brother knew that his wife had gone'

b.  $\begin{matrix} \text{amuna} & \text{aheerh-a} & \text{wira} & \text{at-w-} & \text{aaya} & \text{aho-rwa-a} \\ \text{my brother} & \text{sa/t/think-t} & \text{that} & \text{wife-poss} & \text{sa/t-go-t} & \end{matrix}$  'my brother thought his wife had gone' (implied-and she had)  
 c.  $\begin{matrix} \text{amuna} & \text{aheerh-a} & \text{thoko} & \text{at-w-} & \text{aaya} & \text{aho-rwa-a} \\ \text{my brother} & \text{sa/t-think-t} & \text{that} & \text{wife-poss} & \text{sa/t-go-t} & \end{matrix}$  'my brother thought that his wife had gone' (implied - but she probably hadn't)

d.  $\begin{matrix} \text{amuna} & \text{ahoon-a} & \text{eti} & \text{at-w-} & \text{aaya} & \text{aho-rwa-a} \\ \text{my brother} & \text{sa/t/see-t} & \left\{ \begin{matrix} *wira \\ \text{thoko} \end{matrix} \right\} \begin{matrix} \text{wira} \\ \text{wife-poss} \\ \text{sa/t-go-t} \end{matrix} \end{matrix}$  'my brother thought that his wife had gone' (but she probably hadn't)

As mentioned above, tense and aspect of the matrix verb and the embedded verb are also important, so that with a verb like uthana 'to want' the embedded tensed verb must take the subjunctive. If the matrix verb is in the past tense and the complementizer is wira then the speaker vouches for the evidence supporting his belief. This present tense matrix verb can have only the complementizer 'eti' signalling that the speaker cannot (or possibly will not) vouch for the truth of the complement particularly when that involves a third person. These facts are illustrated by the examples in (26) below.

26. a.  $\begin{matrix} \text{Ararima} & \text{a-no-th} & \text{ahan-a} & \text{eti} & \text{Hin-Nati} & \text{arwee} \\ \text{Ararima} & \text{sa-t-want-t} & \text{that} & \left\{ \begin{matrix} *wira \\ \text{that} \end{matrix} \right\} & \text{Nati} & \text{sa/go/subj} \end{matrix}$  'Ararima wants that Nati leave'  
 b.  $\begin{matrix} \text{Ararima} & \text{aho-thanan-a} & \text{wira} & \text{Hin-Nati} & \text{arwee} \\ \text{Ararima} & \text{sa-t-want-t} & \text{that} & \text{Nati} & \text{sa/go/subj} \end{matrix}$  'Ararima wanted that Nati leave'

In spite of the fact that there are obvious governing factors regarding the choice of complementizer, some of which might turn out to be related to the subcategorization of specific verbs (i.e. ucúwéla, 'to know' and woóná 'to see, think', for example), or related to pragmatics, I am going to gloss over these differences by assuming a single syntactic rule for the purposes of this discussion. The rule in (27a) treats the complementizer as a feature which will henceforth be abbreviated as  $\bar{S}$  (in 27b) according to standard practice.

27. a. [<sub>S</sub> (comp) S]  
           [+comp]
- b. < 11, [ $\bar{S}$  (comp) S] ... >

The parentheses around 'comp' are to insure optionality of the complementizer. It may be omitted so long as lexical semantics and tense/mood are sufficient to determine the strength of the speaker's belief.

Verbs taking sentential complements include ucúwéla 'to know', uth<sup>h</sup>ánáta 'to want', wihánélá 'to expect', 'to hear' and waámíni 'to believe'. Such verbs will then need to have the rule number of (28) below as part of their lexical entry to insure that they occur in such structures. This rule is needed to admit VPs with verbs and sentential complements.

28. < 12, [<sub>VP</sub> V  $\bar{S}$ ] ... >

In addition, some sentential complement taking verbs also take an NP object. Verbs such as uhímérya 'to tell', woóryáníhá 'to persuade', and waámíníhá 'to convince' are verbs which will have included in their lexical entries the rule number for the rule in (29). (It may turn out that waámíníhá 'to convince' would be best analyzed as a causative of waámíni 'to believe' which is a Swahili borrowing but that is not clear yet. If it is, then it

will end up having the rule in (28) by a more indirect route.)

(29) < 13, [<sub>VP</sub> V NP  $\bar{S}$ ] ... >

The rule in (29) will interact with other basic rules to account for examples like those in (30) below.

30. a. Hín-Sepété áhó-n-himéry-á nt<sup>h</sup>ú wiirá ásúúlúpaaly-áále  
 Sepete sa/t-oa-tell-t person that old man-dem  
 áhó-lím-á váá mweécána  
 sa/t-cult-t here last year  
 'Sepete told some person that the old man had cultivated here  
 last year'
- b. Araárima áháá-mwíiréla ámúná wiirá  
 Araarima sa/t/oa-persuade his brother that  
 mwaán-ólé a-hokolyé-é  
 child-dem sa-return-subj  
 'Araarima persuaded his brother that the child should return'
- c. Araárima áháá-mínihá ámúná wiirá  
 Araarima sa/t/oa-convince-t his brother that  
 mwaán-ólé a-hokolyé-é  
 child-dem sa-return-subj  
 'Araarima convinced his brother that the child should return'

Makua also exhibits infinitive complements. Like the sentential complement structures just discussed, there are structures in which the verb is followed by just an infinitive complement and no other NP object and those which have not only an infinitive complement but an object as well. In the first instance, there are verbs such as uthánána 'to want' and ulíká 'to try'. These two verbs can take just an infinitive complement, so that the rule in (31) below will account for this structure. In that rule I have treated the infinitive as a VP, as a verb phrase with a feature on it, which I have abbreviated as  $\bar{VP}$ , in a manner analogous to  $\bar{S}$ . The  $\bar{VP}$  will be admitted by the rule in (31) which will account for the examples like those in (32a) and



(32b).

31. < 14, [<sub>VP</sub> V  $\overline{VP}$ ] ... >
32. a. Araárima áhó-thánán-a u-n-th<sup>h</sup>úma báásikely-úlé  
 Araarima sa/t-want-t inf-oa-buy bicycle-dem  
 'Araarima wanted to buy the/that bicycle'
- b. Araárima áhó-lík-á u-n-thúma báásikely-úlé  
 Araarima sa/t-try-t inf-oa-buy bicycle-dem  
 'Araarima tried to buy that/the bicycle'

In addition to the sorts of structures schematized by the rule in (31) above, then, there are the verbs which take not only infinitive complements but object NPs as well. There will therefore need to be a rule of the sort in (33) below to account (in part) for the examples in (34a) and (34b).

33. < 15, [<sub>VP</sub> V NP  $\overline{VP}$ ] ... >
34. a. Araárima aho-mweéhérér-á mwaán-ólé uhókólyaa  
 Araarima sa/t-oa/expect-t child-dem to return  
 'Araarima has expected (and still does) the child to return'
- b. Araárima aho-moóryáanih-á mwaán-ólé uhókólyaa  
 Araarima sa/t-oa/persuade-t child-dem to return  
 'Araarima has persuaded the child to return'

For the examples just discussed in (34) it is the case that the object is interpreted as the subject of the infinitive (i.e. these are cases of object control). I have no examples of cases analogous to English in which a verb has an object and an infinitive but it is the main subject which is interpreted as the subject of the infinitive. That is, I have no examples like the English 'I promised Lee to go' where the subject is doing the going and not the object. The consultant simply preferred to use the verb uhimérya 'to tell' in such cases. Whether there is no such class of verbs, or whether they would turn up on further investigation is a question that I cannot answer. Should such verbs turn up, their syntactic structure would be the same as that

in (33) above. It would be the semantics which differentiates the translation and so a separate rule would be needed. (See Gazdar (to appear b) for a discussion of how the semantics might work out for such structures).<sup>4</sup>

For verbs which have only infinitive complements and no objects, there is a pattern in which the object of the infinitive not only behaves as the object of the infinitive in that it triggers object agreement in the infinitive as in examples (34) above, but it may also trigger object agreement on the main verb. Examples parallel to such constructions as (34a) and (34b) are given in (35a) and (35b).<sup>5</sup>

35. a. Aráárima áhó-n-thánán-á báásikely-úlé u-n-thúma  
 Araarima sa/t-oa-buy-t bicycle-dem inf-oa-buy  
 'Araarima wanted to buy the/that bicycle'
- b. Aráárima áhó-n-lík báásikely-úlé u-n-thúma  
 Araarima sa/t-oa-try bicycle-dem inf-oa-buy  
 'Araarima tried to buy the/that bicycle'

A possible rule accounting for this construction might be that in (36) which states that a verb may be followed by an NP in turn followed by the infinitive phrase with a hole in it, VP/NP. In this rule I have included a rather crude semantics in order to show that it is the semantics which insures that the NP present is the one semantically treated as the object of the infinitive, i.e. the missing NP.

36. < 16, [<sub>VP</sub> V NP  $\overline{\text{VP/NP}}$ ], >

An analogous pattern exists for verbs taking sentential complements (but not NPs) such as ucúwéla 'to know', wihánela 'to expect', and uthánána 'to want', but not, uhímérya 'to tell', which must have an object NP in addition to the sentential complement. In these cases, an NP from the complement sentence can appear in front of the complementizer. When it does, it

triggers object agreement on the matrix verb (all agreement is intact in the embedded sentence. Compare the examples in (37) below. In (37a) what is semantically the subject of the complement sentence appears in front of the complementizer and not only triggers its own subject agreement in the embedded clause but triggers agreement as the object of the matrix verb. Likewise, in (37b) the object of the complement sentence appears in front of the complementizer and when it does, it triggers object agreement on the main verb.

37. a. Araarima ahaa--thanana amun a wiira a-n-thum-e  
 Araarima sa/t/Oa-want-t his brother that sa-oa-buy-subj.  
 baasikely-ule  
 bicycle-dem  
 'Araarima wanted of his brother that he buy a bicycle'
- b. Araarima aho-n--thanana baasikely-ule wiira amunna a-n-thum-e  
 Araarima sa/t-oa-buy bicycle-dem that (his) brother  
 sa-oa-buy-subj.  
 'Araarima wanted (of) the/that bicycle that his brother buy (it)'
- c. < 17, [<sub>VP</sub> V NP  $\bar{S}$ /NP]... >

Such patterns can be captured by the rule in (37c) which states that a verb followed by a  $\bar{VP}$  can be admitted if it dominates a NP followed by a sentential complement with a NP hole in it. Again, it is the semantics which insure that the NP belongs to the sentence with a hole in it.

I now turn to the rule for adverbs. In Makua, adverbs fall into at least two categories both syntactically and semantically, VP adverbs and S adverbs.<sup>6</sup> I say at least, because there may be a third syntactic pattern, but it is not clear whether the variation is due to the limited data I have or to real syntactic constraints. Therefore, the discussion is limited to adverbs which can be classed into VP adverbs and S adverbs. The following two rules are proposed. The first, introducing VP adverbs, claims that any verb phrase can have an adverb at the end of it. Since the input rule may

have any of the categories permitted in the basic VP rules, the rule in (39a) accounts for the distribution of VP adverbs following NPs or PPs but before  $\overline{VP}$  and  $\overline{S}$ . The notation indicates that any number of adverbs can be admitted (i.e.,  $\alpha$ ,  $\alpha\alpha$ ,  $\alpha\alpha\alpha$ , ...).

39. a.  $\langle n, [_{VP} V \alpha^* \beta^*] \dots \rangle \Rightarrow \langle n, [_{VP} V \alpha^* Adv_{VP}^* \beta^*] \dots \rangle$

where  $\alpha \in \{-V\}$  (i.e. NP and PP)

and  $\beta \in \{+V\}$  (i.e.  $\overline{VP}$  and  $\overline{S}$ )

b. Hín-Sepété áhó-pwés-á ikólé ratáraata  
 Sepete sa/t-break-t coconut carefully  
 'Sepete broke the coconut carefully'

This rule does some work by interacting with other rules to predict an interesting array of facts. One result of this rule is that because adverbs are the result of the output of a metarule, this rule claims that VP adverbs are not part of the basic word order as defined in Chapter III. This seems intuitively wrong, if there is such a thing as basic syntactic order. It suggests that either the definition is amiss or the analysis is wrong.

Sentence adverbs, on the other hand, I propose to introduce by a rule which simply introduces an S node when it dominates an S and a  $Adv_S$ .

40. a.  $\langle 18, [S S Adv_S] \dots \rangle$

b. Hín-Sepété áhó-rwá-á vóhípica  
 Sepete sa/t-go-t immediately  
 'Sepete left immediately'

Thus, VP adverbs are properly within the VP, but sentence adverbs are one level from the S. The utility of the structures for these rules will only become apparent as the analysis progresses, so I will defer discussion of relevant examples until a more appropriate time.

In the following sections, additional orders are given by rules specifying orders induced by unbounded dependencies (section 3.3), and by metarules interacting with the rules presented in this section as well as those in section 3.3.

## 3.2 Unbounded dependencies.

In this subsection I introduce two linking rules which interact with the basic rules so far given and with the derived rules predicted by the derived rule schema, to account for two sorts of unbounded dependencies. Since it will be impossible to show how all the rules interact with all of the other rules, I have chosen one example with four words (which gives twenty-four logical possibilities, all of which occur) to follow through. This example is an applied bitransitive verb with three NP arguments, a subject, an object and an applied object. This first order of the paradigm example is given in (41) below. Whenever possible, an English gloss reflecting the discourse function (rather than its literal translation) is given.

41. SV AO DO  
 Asáapala áhó-n-rúw-él-a mwaán-ólé isímá  
 Asaapala sa/t-oa-cook-app-t child-dem porridge  
 'Asaapala prepared isima for the/that child'

Before progressing to the linking rules, however, two introductory comments are in order. First, one of the ways in which languages may differ in this framework is in the set of derived categories. For Makua, the only derived categories that are needed (so far) are those in (42) below where  $\alpha$  stands for any other non-terminal category in the language. Thus, I am claiming that there are no derived categories  $\alpha/V$ ,  $\alpha/S$ ,  $\alpha/\bar{S}$ , or  $\alpha/Adv$ , for example.<sup>7</sup>

42. a.  $\alpha/NP$  (eg. NP/NP)  
 b.  $\alpha/PP$  (e.g. S/PP)  
 c.  $\alpha/\sqrt{VP}$  (e.g. VP/VP)

These derived categories will, by means of the derived rule schema, interact with the basic rules defined in the previous subsection to predict the rules such as [ $\sqrt{VP}/NP$  V NP/NP] but not [ $\bar{S}/S$  COMP S/S] because there is no such

derived category defined. Rather than list all of the derived rules, they will be assumed to exist and I will go ahead and use them when necessary.

The second comment regards an assumption I am making. Note that as the derived categories were defined, there are no sentences with two gaps in them, i.e. there are no doubly slashed categories of the sort S/NP/NP. There is some apparent evidence from Swedish and Norwegian which suggests that such doubly slashed categories are needed. (See Maling and Zaenen (to appear) and Engdahl (1980)). However, the analysis of Makua makes some interesting predictions if there are no such doubly slashed categories. In addition, the one reasonable place to look for such double gaps (found in other languages) would be in relative clauses. In some languages, it is possible to relativize twice out of a single clause. In Makua this appears not to be possible regardless of the order of the gaps and the NPs they are associated with. Thus, both the examples in (43) below are ungrammatical. Using Fodor's (1978) terminology, the Gap is G, the NP it corresponds to is the filler (F). Intersecting dependencies are those in which Gaps intersect with fillers. Nested are those which do not.

43. a. \*Nested dependency  $F_1 F_2 G_2 G_1$   
 úlá mwaáná ki-no-(ń)-cúwél-á álé-ásúúlúpaále  
 here child sa/t-(o)-know-t that-old man  
 $F_1$   $F_2$   
 $G_2$   $G_2$   
 mwáháá-rúma u-n-lumac-alé  
 sa/t/oa-ask-t inf-oa-talk to-dem  
 'Here is a child (that) I know (that) the old man you asked him  
 to talk to'

- b. \*Intersecting dependency  $F_1 F_2 G_1 G_2$   
 úlá mwaáná ki-no-(ń)-cúwél-á ásúúlúpaále mwáhó-ń-rúma  
 here child sa-t-(oa)-know-t dem-old man sa/t-oa-ask  
 $F_1$   $F_2$   $G_1$   
 waa-lumacalé  
 inf/oa-talk to-dem  
 $G_2$   
 'Here is the child that I know the old man you asked him to talk to'

Taken together, the fact that there are no double gaps in relative clauses and the fact that the analysis makes interesting and correct predictions without doubly slashed categories support the assumption.<sup>8</sup>

I now turn to the linking rules. The first sort of linking rule which accounts for unbounded dependencies and which provides for an additional order for the paradigm example is one which closely resembles topicalization in English. This rule works at the sentence level, so that I will refer to it as S-Topicalization, even though its specification differs slightly from the usual sorts of topicalization. The linking rule is formulated as in (44) below. It will account for sentence initial position of an NP (regardless of its grammatical relation), a PP, and an infinitive phrase ( $\overline{VP}$ ), in sentences like those in (44) below.

44. a. S-Topicalization  
 $18, [S \alpha S/\alpha] \dots$  where  $\alpha \in \{NP, \overline{VP}, PP\}$
- b. Hín-Sepété áhó-thék-á ilúwáni ni-nth<sup>h</sup>ále  
 Sepete sa-t-build-t fence with-bamboo  
 'Sepete built a fence'
- c. S/NP  
 ilúwán-éié Hín-Sepété áhó-thék-á ni-nth<sup>h</sup>ále  
 fence-dem Sepete sa/t-build-t with-bamboo  
 'the fence Sepete built with bamboo'
- d. S/PP  
 ni-nth<sup>h</sup>ále Hín-Sepété áhó-thék-á ilúwáni  
 with bamboo Sepete sa/t-build-t fence  
 'with bamboo Sepete built a fence'
- e. S/ $\overline{VP}$   
 u-n-thúma báásikeli Hín-Sepété áhó-thánán-a  
 inf-oa-buy bicycle Sepete sa/t-want-t  
 'to buy a bicycle Sepete wanted'

The rule in (44) taken together with the sentential complement rule previously motivated, [ $\overline{S}$  (COMP) S], will predict unbounded dependencies. The examples in (45) show that this is the case. NP,  $\overline{VP}$ , and PP may all appear one clause up. A diagram of (45a) is included to show how this works.

45. a. S/NP  
 Araárima aheéwá wiirá ilúwán-élé Hín-Sepété áhó-thék-á  
 Araarima sa/t/hear-t that fence-dem Sepete sa/t/build-t  
 ni-n<sup>h</sup>ále  
 with bamboo  
 'Araarima has heard that the fence Sepete built with bamboo'

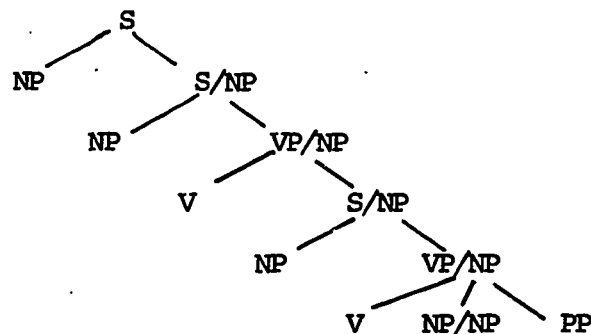

- b. S/PP  
 Araárima aheéwá wiirá ni-n<sup>h</sup>ále Hín-Sepété áhó-thék-á  
 Araarima sa/t/hear-t that with bamboo Sepete sa/t/build-t  
 ilúwáni  
 fence  
 'Araarima has heard that with bamboo Sepete built a fence'
- c. S/ $\sqrt{VP}$   
 Araárima aheéwá wiirá u-n<sup>h</sup>-thúma báásikeli Hín-Sepété  
 Araarima sa/t/hear-t that inf-oa-buy bicycle Sepete  
 áhó-thánán-a  
 sa/t-want-t  
 'Araarima has heard that to buy a bicycle Sepete wanted'

The rules also interact to predict that S-Topicalization should operate in what is generally known in movement analyses as successive cyclic fashion. That is, the topicalized category should be able to appear in front of an intermediate S. While these sentences seem to be controversial in English, they are perfectly good in Makua. Thus in (46a) below, a subject NP from the lower clause is found one clause up. In (46b) it is found two clauses up.

46. a. nt<sup>h</sup>ú áhó-kí-méry-a wiirá ilúwán-élé Araárima aheéw-á  
 person sa/t-oa-tell-t that fence Araarima sa/t/hear-t  
 wiirá Hín-Sepété áhóthéká ni-nt<sup>h</sup>ále  
 that Sepete sa/t-build with-bamboo



46. a. (cont.)  
 'some person told me of the/that fence that Araarima has heard that Sepete built (it) with bamboo'.
- b. ilúwán-élé nt<sup>h</sup>ú áhó-kí-méry-a wiirá Aráárima aheéwá  
 fence-dem person sa/t-oa-tell-t that Araarima sa/t-hear-t
- wiirá Hín-Sepété áhó-thék-á ni-nth<sup>h</sup>ále  
 that Sepete sa/t-build-t with-bamboo  
 'the/that fence some person told me that Araarima had heard of Sepete that (he) built (it) with bamboo'

In addition this rule taken together with the constraint against doubly slashed categories predicts that two NPs cannot be topicalized at once. In example (47a) below, the appearance of two NPs two clauses up (which both belong to the same embedded clause semantically) does not result in a Makua sentence. Any other combination of two of the categories specified in the rule in (44) cannot occur either. The example in (47b), for instance, is ungrammatical because both an NP and a PP from the lower clause appear in front of the higher clause.

47. a. \*mwaánólé Hín-Nnátí Aráárima aheéwá wiirá áhó-n-rúw-éla  
 child Nnati Araarima sa/t/hear/t that sa/t-oa-cook-app  
 isímá  
 porridge
- b. \*ilúwán-élé nínth<sup>h</sup>ály-úlé Aráárima aheéwá Hín-Sepété  
 fence-dem with-bamboo-dem Araarima sa/t-hear-t Sepete  
 áhó-théká  
 sa/t-build  
 'the fence with the bamboo, Araarima heard that Sepete built'  
 (interpretable only as the fence and the bamboo...which is nonsensical)

Among those categories that do not participate in this rule are both  $\bar{S}$  and  $\bar{S}/NP$ , and  $\bar{VP}/NP$ . This is the first restriction on word order so far. Thus, any of these categories does not appear preceding a higher embedding verb (as in (48)). Note that the lack of topicalization of  $\bar{VP}/NP$  and  $\bar{S}/NP$

is immediately ruled out since categories such as  $VP/\overline{VP}/NP$  and  $VP/\overline{S}/NP$  are undefined.

48. a.  $S/\overline{S}$   
 \*wiirá Hín-Sepété áhó-thék-á ilúwáni ni-ńt<sup>h</sup>ále Aráárima  
 that Sepete sa/t-build-t fence with-bamboo Araarima  
 aheéw-á  
 sa/t/hear-t
- b.  $S/(\overline{S}/NP)$   
 \*wiirá Hín-Sepété áhó-thék-á ni-ńt<sup>h</sup>ále Aráárima aheéw-á  
 that Sepete sa/t-build-t with-bamboo Araarima sa/t/hear-t  
 ilúwáni  
 fence
- c.  $S/(\overline{VP}/NP)$   
 \*u-ń-thúma Aráárima aheéw-á wiirá Hín-Sepété  
 inf-oa-buy Araarima sa/t/hear-t that Sepete  
 áhó-ń-thánán-á báásikeli  
 sa/t-oa-want-t bicycle

For the paradigm example in (41) then, the orders in (49) have been accounted for so far. The abbreviations are straightforward, S = subject, V = verb, DO = the semantic direct object, AO = the semantic applied object. Each order is followed by the rule or rules which account for that order. (Some change in the distribution of demonstratives can be noted in the paradigm example.) These reflect the discourse function of various orders and do not interact in sentence grammar as I have developed it here.

49. a. S V AO DO (basic rules and metarules introducing objects)  
 Asáápala áhó-ń-rúw-él-á mwaán-ólé isímá  
 Asaapala sa/t-oa-cook-app-t child-dem porridge  
 'Asaapala prepared porridge for the/that child'
- b. AO S V DO (S-Top)  
 mwaán-ólé Asáápala áhó-ń-rúw-él-á isímá  
 'For the child Asaapala prepared isima'
- c. DO S V AO (S-Top)  
 isím-élé Asáápala áhó-ń-rúw-él-á mwaán-ólé  
 'the/that porridge, Asaapala prepared for the/that child'

The second rule involving unbounded dependencies is one which shares some properties with the S-Topicalization rule just given. The rule applies within the VP, however, to place just one NP, a PP or a  $\overline{VP}$  in front of the verb. I am actually a little unsure whether  $\overline{VP}$  should be included since sentences with the order NP  $\overline{VP}$  V X are generally judged to be poetic. Yet, they seem to be perfectly grammatical. The rule can be formulated as follows.

## 50. VP-Topicalization

$$\langle 19, [{}_{VP} \alpha \text{ VP}/\alpha], \dots \rangle \quad \alpha \in \{NP, PP, \overline{VP}\}$$

Examples of the structures the addition of this linking rule admits are given in (51) below. A diagram for (51a) is included to show just what the structure will be.

51. a. VP/NP  
 Hín-Sepété ilúwán-élé áhó-thék-á ni-nt<sup>h</sup>ále  
 Sepete fence-dem sa/t-build-t with-bamboo  
 '(As expected) Sepete did build the fence and it was with bamboo'

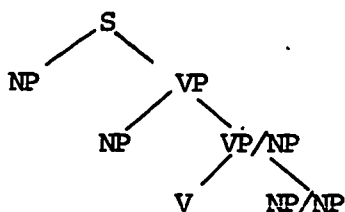

- b. VP/PP  
 Hín-Sepété ni-nt<sup>h</sup>ály-ulé áhó-thék-á ilúwáni  
 Sepete with-bamboo-dem sa/t-build-t fence  
 '(As expected) Sepete did build using the bamboo and it was a fence'
- c. VP/ $\overline{VP}$   
 Hín-Sepété u-n<sup>h</sup>-th<sup>h</sup>uma báásikeli áhó-thánán-a  
 Sepete inf-oa-buy bicycle sa/t-want-t  
 '(As expected) Sepete did want to buy a bicycle'

Importantly, this linking rule will interact with other rules in the grammar to predict that an NP, a PP, and or a  $\overline{VP}$  belonging semantically to an embedded sentence may appear between the subject and verb of the matrix verb

of the sentence. This is because the tree in (52) below will be analyzed by the rules of the grammar. The rule admits the S node. The VP-Topicalization linking rule just written admits the VP node which is in turn linked to derived categories admitted by the derived rules.

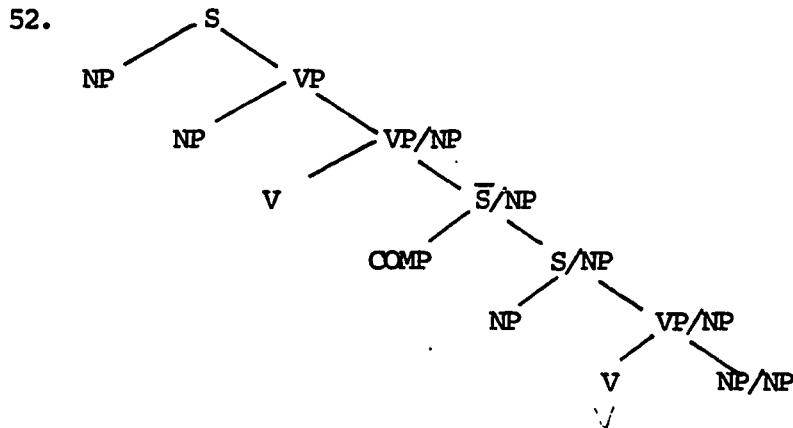

The orders induced by such interactions of rules are perfectly good as the examples in (53) show. In (53a) an object NP belonging semantically to the lower clause is found between the subject and verb of the matrix clause. In (53b) that NP belonging semantically to the lower clause is found two clauses up, in between the subject and verb of that clause. (54) contains parallel examples for subject NPs.

53. a. Hín-Sepété báásikely-úlé aho-ń-cúwél-á wiirá nt<sup>h</sup>ú  
 Sepete bicycle-dem sa/t-oa-know-a that person  
 ho-ń-th<sup>h</sup>yáa  
 sa/t-oa-break  
 'Sepete knows of the bicycle that someone has broken it'
- b. ásuúlpáaly-ále báásikely-úlé néera wiirá Aráarima  
 old man-dem bicycle-dem sa/t/say/t that Araarima  
 aho-ń-cúwél-a wiirá nt<sup>h</sup>ú ho-ń-th<sup>h</sup>yáa  
 sa/t-oa-know-a that person sa/t-oa-break  
 'The old man says of the bicycle that Araarima knows that some person has broken it'

54. a. Hín-Sepété ikitaábw-ilé áhó-káámíníh-a wiirá y-oréér-a  
 Sepete book-dem sa/t-oa-convince-t that sa-good-t  
 u-sómá  
 inf-read  
 'Sepete convinced me of that book that (it) is good to read'
- b. Araárima ikitaábw-ilé néera wiirá Hín-Sepété áhó-  
 Araarima book-dem sa/t/say that Sepete sa/t-  
 káámíníh-a wiirá y-orééra u-sómá  
 oa/believe-t that sa - good inf-read  
 'Araarima says of the book that Sepete convinced me (it) is  
 good to read'

Because there are no doubly slashed categories, however, one expects to find that no more than one of the categories may show up at a time in between the subject and the verb of a higher clause. (Two or more of these categories can be found in between the subject and the verb of the clause to which they belong semantically, but these structures, I will argue, arise from different kinds of rules.) This prediction is borne out as the ungrammaticality of the examples in (55) attests.

55. a. NP/NP  
 \*Hín-Sepété nt<sup>h</sup>-úlé báásikely-úlé áhó-ń-cúwél-á wiirá ho-ń-th<sup>h</sup>yáa
- b. VP/NP/PP  
 \*Araárima ni-nt<sup>h</sup>úlé Hín-Sepété néer-a wiirá áhó-thék-á  
 Araarima with-bamboo Sepete sa/t/say-t that sa/t-build-t  
 ilúwáni  
 fence

With the adoption of the VP-Topicalization rule and the then, two more orders of the paradigm example are accounted for.

56. a. S AO V DO (VP-Top)  
 b. S DO V AO (VP-Top)

A third linking rule involving unbounded dependencies is eventually added to the grammar. However, its motivation will become clearer after discussion of the metarules in the following section. It will be taken up at a more

appropriate time.

### 3.3 Metarules

In this section metarules accounting for the rest of the orders in the paradigm example are given. These interact with the basic rules in (3.1) and the linking rules in (3.2) as well as with each other. Again, it is impossible to give all the possible structures that the interactions of these rules permit, so that I will stick to the paradigm example and present other examples where relevant.

One order which appears to have no subcategorization restrictions and no syntactic features different from the orders predicted by the input of the metarule to follow is one in which the subject NP immediately follows the verb.<sup>9</sup> To capture this relatedness the metarule in (57) is proposed. Note that it is the semantic translation which keeps the grammatical relations straight. The  $\mathcal{F}$  stands for the semantic translation for each of the input rules which will be in this case a VP meaning. That VP meaning is a function to which the NP meaning is applied (yielding a sentence meaning). Thus, the S node admitted will not have a syntactic verb phrase but there will still be one in the semantics.

#### 57. Verb-Initial

$$\langle n, [_{VP} V X], \mathcal{F}' \rangle \implies \langle n, [_{S} V NP X], \mathcal{F}' (NP') \rangle$$

In that this order (essentially VSO) has no syntactic verb phrase but that SVO does, is a claim that must be substantiated. The evidence for this is, however, in the agreement analysis, so that the reader will have to take these structures on faith for the moment. This metarule will predict the existence of rules in the grammar such as in (58). Grammatical

examples corresponding to those orders are found in (59).

58. a. [<sub>S</sub> V NP  $\bar{S}$ ]

b. [<sub>S</sub> V NP  $\overline{VP}$ ]

59. a. [<sub>S</sub> V NP  $\bar{S}$ ]

aho-cúwél-a Hín-Sepété wiirá ikitáábwilé y-orééra  
sa/t-know-t Sepete that book-dem sa-good

u-sómá

inf-read

'(What happened was that) Sepete knows that the/that book is good to read'

b. [<sub>S</sub> V NP  $\overline{VP}$ ]

áho-th<sup>h</sup>ánán-a Hín-Sepété u-ń-th<sup>h</sup>úma báasikeli  
sa/t-want-t Sepete inf-oa-buy bicycle

'(What happened was that) Sepete wanted to buy a bicycle'

If, in contrast to the metarule written above, this order were the result of a verb gap, i.e. the result of a linking rule like [<sub>S</sub> V S/V] one would expect that verbs could be found outside the clause to which they belong semantically because there would be nothing to prevent a structure like that in (60) from being admitted.

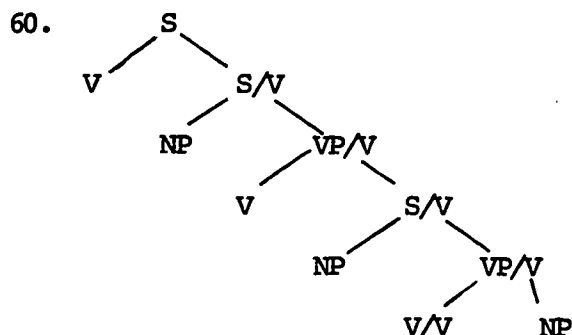

This appears to be an incorrect prediction since verbs are not found outside the clauses they belong to. Thus, the example such as that in (61) where a verb is found outside its own clause is ungrammatical.

61. \*Asáápala ho-thék-á áhó-cúwél-a wiirá mwaánólé ilúwáni  
 Asaapala sa/t-build-t sa/t-know-t that child-dem fence  
 ni-nt<sup>h</sup>ále  
 with-bamboo

In addition to the example in (61), the Verb-Initial rule (V-I) will interact with the linking rules and derived rules. Thus, (among others) there will be a derived rule like that in (62).

62. [<sub>S/NP</sub> V NP NP/NP]

The rule in (62) will then interact with the S-Topicalization rule in such a way as to provide for two additional orders for the paradigm example. These are given in (63a-c). An abbreviated tree diagram for (63a) will show how this is so. (63c) includes the order induced by the Verb-Initial rule alone. This brings the total to eight for the orders of the paradigm example.

63. a. AO V S DO (S-Top and V-I)  
 mwaánólé áhó-ń-rúw-él-á Asáápala isímá  
 '(What happened was that) the/that child, Asaapala prepared porridge (for it)'

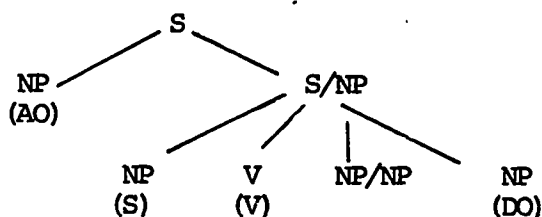

- b. DO V S AO (S-Top and V-I)  
 isím-élé áhó-ń-rúw-él-á Asáápala mwaán-ólé  
 '(about) the/that isima (what happened was that) Asaapala prepared (it) for the child'
- c. V S AO DO (V-I)  
 áhó-ń-rúw-él-á Asáápala mwaán-ólé isímá  
 '(What happened was that) Asaapala prepared isima for the child'

The rule interactions thus far allow for structural ambiguity (e.g.

S V AO DO is structurally, though not semantically ambiguous). This ambiguity



will be reduced in more complicated sentences, but it is a feature of the whole system.

Another common pattern is one in which the subject NP appears at the end of a sentence. Again, there appear to be no subcategorization or syntactic feature restrictions differentiating the input rules from the output rules so that a metarule NP Final is (64) is proposed. This rule claims sentences with an initial NP (the subject) are related to sentences with a final (subject) NP.

64. NP Final

$$\langle n, [{}_S \text{ NP X}] \dots \rangle \implies \langle n, [{}_S \text{ X NP}] \rangle$$

In addition to the additional orders for the paradigm example to be given in (65) below, the addition of the NP Final Rule will predict that subject NPs from the matrix sentence can appear at the end of the embedded clause, i.e. at the end of the whole sentence. That this is correct is illustrated by the example in (65).

65. a. [<sub>S</sub> VP NP]  
 áhó-cúwél-a wiirá mwaánó áhó-thék-á ilúwaní ni-ńt<sup>h</sup>ále  
 sa/t-know-t that child-dem sa/t-build-t fence with-bamboo  
 Araárima 'Araarima knew that a child built a fence  
 Araarima with bamboo'
- b. [<sub>S</sub> VP NP]  
 áháándík-a ibáruwa ratáraata Hín-Sepété  
 sa/t-write-a letter carefully Sepete  
 'A letter was written carefully by Sepete'

It is worth pointing out that neither the Verb - Initial rule nor the NP Final rule will allow an NP from the matrix clause to appear within the embedded clause itself. Such examples are, in fact, ungrammatical as illustrated by the examples in (66) below.

66. a. \*áhó-cúwél-a wiirá Asáápala mwaán-ólé áhó-thék-a ilúwáni  
 sa/t-know-t that Asaapala child-dem sa/t-build-t fence
- b. \*áhó-cúwél-a wiirá mwaán-ólé Asáápala ilúwáni  
 sa/t-know-t that child-dem Asaapala fence

One structure which appears to have a subject NP within the embedded sentence is exemplified in (68) below. This example, I will claim, is subject to an analysis in which the subject NP in question is not in fact within the embedded sentence.

As stated, the metarule in (64), i.e. the NP Final rule, also predicts the existence of a rule of the form [<sub>S</sub> S/NP NP]. This is because one of the linking rules, (S-Topicalization), is of the form [<sub>S</sub> NP S/NP]. If the variable X in the metarule can be anything, then it can be S/NP as well. The addition of the rule [<sub>S</sub> S/NP NP] however, is going to predict that an NP from the embedded clause can appear outside of its own clause to the right. That is, this rule will predict unbounded dependencies to the right. A tree diagram will help show how this would be possible.

67. a. < 20, [<sub>S</sub> S/NP NP] ... >

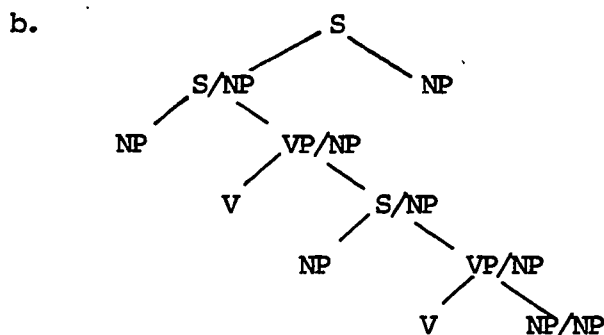

Since this sort of interaction has been of some theoretical interest in the study of English ever since Ross (1967) first proposed that rightward movement was clause bounded, and Chomsky (1977) built this constraint into the Revised Extended Standard Theory, this prediction merits some discussion. I will

say at the outset that the data are not entirely clear, although certain facts can be accounted for if [<sub>S</sub> S/NP NP] is admitted into the grammar. Consider the example in (68) below. In that example, the subject of the matrix verb appears next to last in the sentence while the object of the embedded verb appears in last position.

68. áhó-cúwél-a wiirá mwaán-ólé áhó-thék-á nít<sup>h</sup>ále Araarima<sup>S<sub>1</sub></sup>  
 sa/t-know-t that child-dem sa/t-build-t with-bamboo Araarima  
<sup>O<sub>2</sub></sup>  
 ilúwán-élé  
 fence-dem  
 'What happened was that someone knew that the child had built something with bamboo and Araarima is the one who knew that and it turned out to be the fence that got built'

Now if there is the NP-Final metarule in (64) which takes the subject NP to the end, predicting a sort of rightwards topicalization, [<sub>S</sub> S/NP NP] (which puts the object NP last) then the sentence in (68) above could have as its structure that in (69) below.<sup>10</sup>

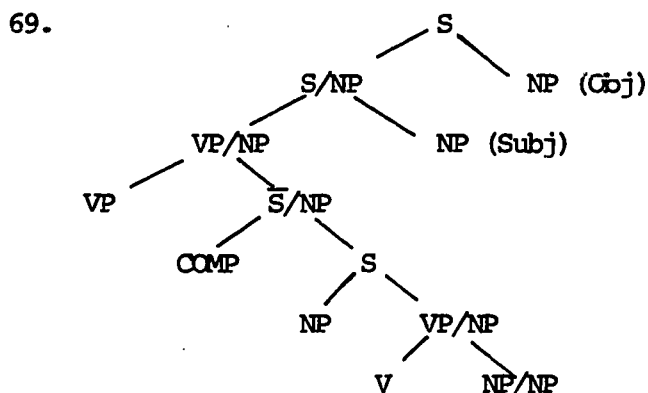

Importantly, both the subject NP and the object NP of the embedded S cannot appear following the subject NP of the matrix verb. Since there can be no doubly slashed categories, and since there are no other rules in this analysis to analyze such an order, the sentence (in 70) is correctly predicted to be ungrammatical.

70. \*áhó-cúwél-a wiirá áhó-thék-á ni-nt<sup>h</sup>ále Araárima  
 sa/t-know-t that sa/t-build-t with-bamboo Araarima <sup>S<sub>1</sub></sup>
- <sup>S<sub>2</sub></sup>  
 mwaán-ólé ilúwán-ólé  
 child-dem fence-dem <sup>2</sup>

In collecting the sentences like that in (68) above, the consultant's reaction at first was that the last NP constituted an afterthought; his judgement was that such constructions might not be a single sentence. After a moment's reflection he remarked that if the final NP was marked with a demonstrative, then his intuition was that such structures constituted a single sentence. Thus, there are clear indications that there is a discourse function associated with structures allowed by [<sub>S</sub> S/NP NP]. This fact is of course not represented here.

Similar patterns can be observed with respect to the placement of NPs and sentential adverbs. Recall that the sentential adverb rule is [<sub>S</sub> S Adv]. If there is no N [<sub>S</sub> S/NP NP] rule, then, at present, there is no way to account for VX Adv<sub>S</sub> NP order. If there is such a rule, then there is a prediction that just one NP can be found beyond a sentence adverb (since two NPs cannot be "extracted"). This is an accurate reflection of the facts since one NP after a sentence adverb is just fine (although it should be marked by a demonstrative) while two NPs are not. Demonstratives don't help this time. Compare the examples in (71).

71. a. áháándík-a ibáruwa vóhípica Hín-Sepété  
 sa/t/write-t letter immediately Sepete  
 'What happened to Sepete is that he wrote the letter immediately'
- b. \*áháándík-a vóhípica Hín-Sepété ibáruw-élé  
 sa/t-write-t immediately Sepete letter-dem

VP adverbs on the other hand, behave differently. Recall the rule introducing VP adverbs, [<sub>VP</sub> V X Adv<sub>VP</sub>]. Two NPs are markedly better following a

VP adverb than following a sentence adverb. Compare the example in (72) below with the example in (71b) above. The example in (72) could be the result of interaction between the NP Final rule and  $[_S \text{ NP S/NP}]$  rule. The final object again must be marked by a demonstrative if it is to be part of the same sentence. The abbreviated tree diagram in (72b) corresponding to the example in (72a) shows that the subject NP is at the end of its clause by the NP Final rule while the object NP is "topicalized out" to the right of the subject NP.

72. a. áháándík-a ratáráata híń-Sepété ibárúw-élé  
 sa/t/write-t carefully Sepete letter-dem  
 'What happened to the letter was that Sepete wrote it carefully'

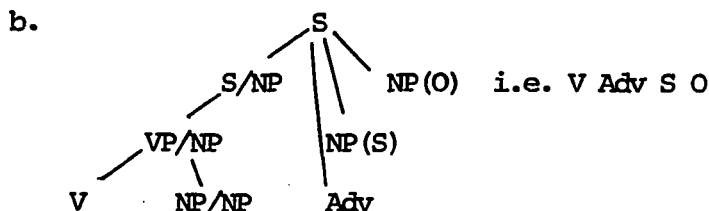

The opposite order,  $V \text{ Adv}_{VP} O S$ , is also attested, but that order cannot yet be analysed by the rules so far. This order will be discussed at a later point.

The evidence from the adverbs and from the complement sentences suggests that the formulation of the NP Final metarule in (64) is not too general, i.e. that there is a rule  $[_S \text{ S/NP NP}]$ . The problem is that the further away NPs get, that is, the further up the tree, the worse the examples get. However, it could be the case that such rightward dependencies are bounded by constraints other than strictly syntactic ones, say, processing. Such a claim has been made for some analyses of English in which unbounded rightward movement is restricted. See Gazdar (to appear b) for a discussion of these facts in the context of this framework .

Thus I propose to leave the NP Final metarule as it is in (64). Its

addition to the grammar will, taken together with other rules discussed thus far, account for the additional orders exemplified for the paradigm example in (73) below. An abbreviated tree diagram is given for (73b) and (73d) to illustrate how these work. In (73b) the subject is found at the end of the clause because it can always be there (i.e. by the NP Final Rule). The applied object is topicalized out to the left. In (73d) on the other hand the subject is at the end of its clause but the direct object has been topicalized out by the NP to the Right rule.

73. a. V AO DO S (NP Fin.)  
 áhó-ń-rúw-é-lá mwaán-ólé isímá Asáápala  
 'What happened was that Asaapala prepared isima for the/that child'
- b. AO V DO S (NP-Fin. and S-Top.)  
 mwaán-ólé áhó-ń-rúw-é-l-á isímá Asáápala  
 '(about) the/that child, what happened was that Asaapala prepared isima (for it)'

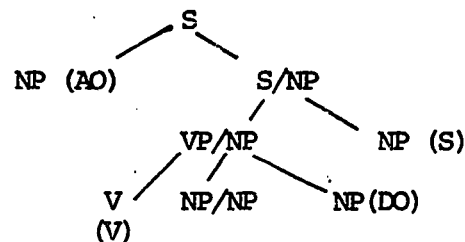

- c. DO V AO S (NP-Fin. and S-Top)  
 isím-élé áhó-ń-rúw-é-l-á mwaán-ólé Asáápala  
 '(about) the/that porridge, Asaapala prepared (it) for the child'
- d. V AO S DO (NP-Fin and Rt. Top.)  
 áhó-ń-rúw-é-l-á mwaán-ólé Asáápala isím-élé  
 'What happened was that Asaapala prepared the isima for the child'

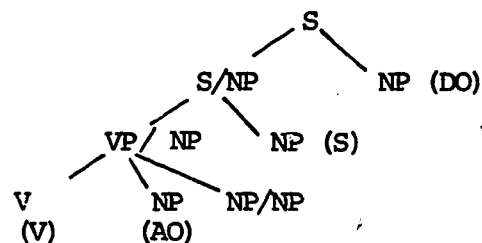

- e. V DO S AO (NP-Fin. and Rt. Top)  
 áhó-ń-rúw-él-á isímá Asáápala mwaán-ólé  
 'What ha-pened was that Asaapala prepared porridge and it was  
 for the/that child'
- f. V S DO AO (V-Prep and [<sub>S</sub> S/NP NP])  
 áhó-ń-rúw-él-á Asáápala isímá mwaán-ólé  
 'What happened was that Asaapala prepared isima and it was  
 for the/that child'
- g. S V DO AO ([<sub>S</sub> S/NP NP])  
 Asáápala áhó-ń-rúw-él-á isímá mwaán-ólé  
 'Asaapala prepared isima for that (the) child'

The remaining metarules are less easily motivated. The evidence that these rules are distinct not only from each other but from the rules discussed so far comes largely from consideration of their interaction with various kinds of complement structures. Thus, it is restrictions on where such complements can go, as distinct from NPs, for example, which allow the processes to be separated out. I would like to stress that I am relying to a considerable extent on the speakers' intuitions here, that is, fine distinctions between odd, poetic, and downright ungrammatical. Whenever appropriate I will include the judgments of the speaker so that the reader is aware of the fluidity of judgements.

The first metarule of this sort is one which insures that some, but not all, categories following the verb in the verb phrase can be found between the subject and the verb. This rule is needed, for example, to account for the order S AO DO V. The facts to be accounted for are that NP, PP,  $\overline{VP}$  and  $Adv_{VP}$  can appear in this position, but that  $\overline{VP}/NP$ ,  $\overline{S}$ , and  $\overline{S}/NP$  cannot. These patterns are exemplified by the grammatical examples in (74) below and the ungrammatical examples in (75).

74. a. [<sub>VP</sub>  $\overline{VP}$  V]  
 Hín-Sepété u-n-thúma báasikeli áhó-thánán-a  
 Sepete inf-oa-buy bicycle sa/t-want-t  
 '(As expected) Sepete wanted to buy a bicycle'
- b. [<sub>VP</sub> Adv<sub>VP</sub> V]  
 Hín-Sepété ratá-ráata áhó-táng-á indángó  
 Sepete well sa/t-read-t story  
 '(As expected), Sepete read well and he read a story'
75. a. [<sub>VP</sub>  $\overline{S}$  V]  
 \*Hín-Sepété wiirá mwaánólé áhó-thék-á ilúwáni áhó-  
 Sepete that child-dem sa/t-build fence sa/t-  
 cúwél-a  
 know-t
- b. [<sub>VP</sub> NP  $\overline{S}$ /NP V]  
 \*Hín-Sepété mwaán-ólé wiirá áhó-théká ilúwáni áhó-cúwél-a  
 Sepete child-dem that sa/t-build fence sa/t-know-t
- c. [<sub>VP</sub> NP  $\overline{VP}$ /NP V]  
 \*Hín-Sepété báasikely-ulé u-n-th<sup>h</sup>úma áhó-n-thánán-á  
 Sepete bicycle - dem inf-oa-buy sa/t-oa-want-t

The metarule proposed in (76) below, which I will term the Variable Order VP rule, is restricted to apply just to the categories which appear before the verb. Obviously, it will allow for a multitude of orders. For instance, one of the outputs is given in (76b) below. (76b) also fits the input structural configuration, so that another rule in 78c is predicted. Essentially, what (76) does is to allow any category (except those stipulated) to appear between the subject and the verb.

#### 76. Variable Order VP

$$[\text{VP } X \text{ V } \alpha \text{ Y}] \implies [\text{VP } X \alpha \text{ V } Y] \quad \text{b. } [\text{VP } \text{NP } \text{V } \text{NP}]$$

$$\alpha \in \{\text{NP}, \overline{\text{VP}}, \text{PP}, \text{Adv}_{\text{VP}}\} \quad \text{c. } [\text{VP } \text{NP } \text{NP } \text{V}]$$

Among the orders accounted for by the metarule in (76) are six more of the paradigm example. Since the rule interactions are getting pretty complicated at this point, some explication is in order. (77a) is now anal-



alyzed by the grammar by virtue of the metarule in (76) which predicts the existence of a rule [<sub>VP</sub> NP NP V]. Recall that it is the semantics which keeps the grammatical relations straight. In (77e) the verb is at the end of the verb phrase via the metarule just proposed. The subject is at the end of the sentence due to the NP Final rule and, finally, the DO is topicalized out to the left. The third paradigm example to be discussed is (77f) in which the verb is again last, due to the last mentioned metarule, and the DO is topicalized according to the specifications of the VP-Topicalization rule.

77. a. S AO DO V (V-O VP)  
 Asáápala mwaán-ólé isím-élé áhó-ń-rúw-éíá  
 '(As expected) Asaapala prepared the isima for the child'

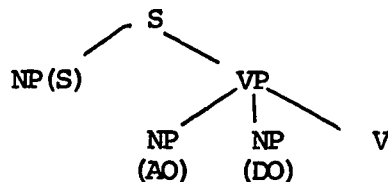

- b. AO S DO V (V-O VP and S-Top)  
 mwaán-ólé Asáápala isím-élé áhó-ń-rúw-él-á  
 'for the child, Asaapala prepared the porridge as expected'
- c. DO S AO V (V-O VP and S-Top)  
 isím-élé Asáápala mwaán-ólé áhó-ń-rúw-él-á  
 'the isima Asaapala prepared for the child (as expected)'
- d. AO DO V S (V-O VP and NP-Fin.)  
 mwaán-ólé isím-élé Asáápala áhó-ń-rúw-él-á  
 'for the child isima was prepared by Asaapala (as expected)'
- e. DO AO V S (V-O VP, NP-Fin, and S-Top.)  
 isím-élé mwaán-ólé áhó-ń-rúw-éíá Asáápala  
 'the/that isima was prepared for the child as expected and it was Asaapala who did it'
- f. S DO AO V (V-O VP and VP-Top).  
 Asáápala isím-élé mwaán-ólé áhó-ń-rúw-él-á  
 'As expected, Asaapala prepared that porridge for the child'

It is as important to characterize which orders are allowed by the

Variable Order VP rule as it is to characterize which orders are not allowed by this rule. In particular, this rule does not allow for both an AO and a DO to follow a sentential complement. As far as I can tell such orders are not good. Again, it was a little hard for the consultant to decide whether these were functionally aberrant in some fashion or just plain ungrammatical. Assuming them to be ungrammatical, then, the prediction made by the metarule is borne out. It is not ungrammatical for one NP to be at the end of the complement sentence, however. I will return to this fact and its implications later. Note that given the rule [<sub>S</sub> S/NP NP], one would expect this order to be grammatical in any case. Compare the examples in (78a) and (78b).

78. a. \*Ki-haá-mínih-él-á wiirá mwaán-ólé arwée nt<sup>h</sup>ú Araárima  
 I-t/oa-convince-app-t that child-dem sa-go/t s.o. Araarima
- b. Ki-haá-mínih-él-á nt<sup>h</sup>ú wiirá mwaán-ólé arwée Araárimalé  
 'I convinced someone that the child should go, on behalf of  
 Araarima'

Of the remaining examples in the paradigm example to be accounted for, there are two which share similar properties with those accounted for by the metarule in (76) above: AO DO S V and DO AO S V. In these examples, categories belonging after the verb are found before both the subject and the verb. Again, the facts are that NP, PP, VP, and Adv<sub>VP</sub> can be found in this position while  $\overline{VP}/NP$ ,  $\overline{S}$ , and  $\overline{S}/NP$  cannot. Their distribution is as in (79) below.

79. a. [<sub>S</sub>  $\overline{VP}$  NP V]  
 u-ń-thúma baásikeli Araárima áhó-thánán-a  
 inf-oa-buy bicycle Araarima sa/t-want-t  
 'to buy a bicycle (is what) Araarima wants'

- b. [<sub>S</sub> Adv<sub>VP</sub> NP NP NP V]  
 ratarataa mwaanole isimele Araarima aho-n-ruw-el-a  
 carefully child-dem porridge-dem Araarima sa/t-oa-prepare-  
 app-t  
 'carefully for the child the porridge Araarima prepared'
- c. \* [<sub>S</sub>  $\bar{S}$  NP V]  
 wiira mwaan-ole aho-thek-a iluwani Araarima aho-cuwel-a  
 that child-dem sa/t-build-t fence Araarima sa/t-oa-know-t
- d. \* [<sub>S</sub> NP  $\bar{S}$ /NP NP V]  
 mwaan-ole wiira aho-thek-a iluwani Araarima aho-n-cuwel-a  
 child-dem that sa/t-build-t fence Araarima sa/t-oa-know-t
- e. \* [<sub>S</sub> NP  $\overline{VP}$ /NP NP V]  
 baasikely-ule aho-n-thuma Araarima aho-n-thanana  
 bicycle sa/t-oa-buy Araarima sa/t-oa-want

By making the output of the metarule in (76) above the input to the metarule in (80) below, we account for the fact that just those categories that precede the verb in the verb phrase can precede both the verb and the subject.<sup>10</sup>

80. Variable Order S-Rule

[<sub>VP</sub> X  $\alpha$  V Y]      [<sub>S</sub> X  $\alpha$  NP V Y]

For the sake of completeness, I include the two crucial paradigm examples.

81. a. AO DO S V  
 mwaan-ole isim-ele Asaapala aho-n-ruw-ela  
 'For that child, (as expected) porridge was prepared by Asaapala'
- b. DO AO S V  
 isim-ele mwaan-ole Asaapala aho-n-ruw-el-a  
 'that porridge, it was prepared for the child by Asaapala (as expected)'

The remaining order from the paradigm example to be accounted for is V DO AO S. When the applied objects were first introduced, that rule placed them next to verbs. I have no real syntactic evidence that this order is the correct choice. It is the case that in ambiguous sentences, the first

postverbal NP is taken to be the applied object out of context, but it is hard to make this fact into a convincing syntactic argument. But it is clear that the order DO AO is needed as well. That this order is not yet accounted for suggests either a revision of the variable order VP rule to allow for this order, or either of the two rules in (82) below are needed.

82. a.  $[_{VP} V NP X] \Rightarrow [_{VP} V X NP]$   
 b.  $[_{VP} VP/NP NP]$

Either of the two rules in (82) above will account for the fact that only one object NP can be found after the sentential complement (as in (78) above) because each affects only one NP. However, the metarule (82a) allows only one AO to appear in this position because it is the one next to the verb in the input rules, while the second will allow for the AO or DO in this position. As far as I know, the facts support the second choice. This choice has the formal advantage in that it may allow the topicalization rules to be collapsed. However, there are some predictions that I am unsure about, i.e. the interaction of these two rules with the third class of adverbs, which I haven't discussed at all. The correct account of this order, is, as far as I am concerned, still open.

Some analysis along the lines just discussed is needed, however, because the order S V DO AO has only been arrived at by the addition of the rule  $[_S S/NP NP]$  to the grammar. That rule, recall, had associated with it some discourse function and it is clear that the S V DO AO order does not have the degree of emphasis other structures of this sort have. Of course, it could be that there is no functional unity to these rules in any case or that the function was attributable to distance rather than structure. Adoption of either (82a) or (82b) above seems justified with some evidence favoring

(82b). Either will account for the order in the last paradigm example in (83) below.

83. V DO AO S  
 áhó-rí-rúw-éla isímá mwaána Asáápala  
 'What happened was that Asaapala was the one who prepared isima  
 for a child'

It is worth pointing out that the introduction of the metarule in (80) above, that rule which related structures with the verb final in the verb phrase and the verb final in the sentence are related in much the same way that the VP-Topicalization rule and the S-Topicalization rule were. That is, essentially the same rules characterize structures at the VP level as at the S level. This is an interesting observation and it suggests that there is further justification for the treatment of S as the maximal projection of VP.

#### 4. Conclusions

The analysis of Makua word order began with a treatment of basic rules, i.e. those orders defined by rules not the output of some metarule nor the result of either the derived rule schema or linking rules. These rules defined a single fixed basic order for Makua, essentially SVO in familiar typological terms. It is appropriate to discuss whether this choice had any particular merit for the analysis of Makua. If one looks beyond just the subject, verb and object, to other categories, then it is possible to argue that this order is to be preferred over OSV, SOV, or OVS. Suppose, for simplicity's sake, that we take O to be any category admitted in a VP, eg. NP,  $\bar{S}$ ,  $\bar{S}/NP$ ,  $\bar{VP}$ , or  $\bar{VP}/NP$ . It would not be possible to state generalizations for Makua is, for example, one picked OSV as the basic order since then, the categories which did not appear in this position (e.g.  $\bar{VP}/NP$ ,  $\bar{S}$ , and  $\bar{S}/NP$ )

would have to be part of rules specifying that they follow the verb. In this way, the verb phrase would not have unified order V O where O, remember, is any sort of category admitted into a VP. Rather, the basic order for verb phrases would be O V in some cases and V O in others. Should one believe that such a statement is not general enough then the order V O is to be preferred. The same argument goes for the SOV and OVS orders since the categories are the same ones involved.

However, there seems to be no argument available for choosing between SVO, VSO, and VOS since there are no comparable restrictions that can be appealed to for these orders. That is, the metarules introducing the subject following the verb (V-Initial) and placing it sentence final (NP Final) were entirely without restrictions of the sort found for the Variable Order VP rules and Variable Order S rules.

It is premature to draw any conclusions from this result about basic order as defined in this framework (i.e. that the notion basic order is either inappropriate or undefined) since it could always be the case that further analysis of more detailed constructions would reveal further arguments for choosing one order over another.

In addition to the above indeterminacy of the analysis with respect to the choice of a basic order, there is a second issue. This issue is raised by my analysis of the derived verbs by metarule which claims, according to the definition of basic order, that bitransitive verb phrases do not form part of the basic order. Again, it is unclear whether this is a criticism of the analysis, or the definition of basic word order, or whether it is any criticism at all, since these verb phrases do have derived verbs in them morphologically speaking and having derived syntactic verb phrases makes intuitive sense.

One conclusion is clear, however, and that is that it is possible to account for a language with as much word order variation as Makua in a fairly general fashion within a phrase structure grammar. This particular grammar made some claims about the interactions of rules and their relative clause boundedness so that it was possible to separate out different syntactic interactions. The choices between rule types and, in particular, the existence of a syntactic verb phrase in some orders but not others, is further substantiated in the analysis on verb agreement in Chapter V and relative Clauses in Chapter VI. Before going on to these analyses, I would like to stop and compare the present analysis with three other proposals that have been proposed for languages with word order freedom.

#### 5. Implications

Languages such as Makua with greater or lesser degrees of word order freedom have been problematic for syntactic theory since the inception of transformational grammar. The existence of these languages, in contrast to English which allows little variation in order, has prompted the addition of various sorts of formal devices to linguistic theory. Three such proposals are taken up here. One is the scrambling rule proposed by Ross (1967) for Latin. The second is Hale's (1979) single category rule motivated by the behavior of such languages as Walbiri. The third such device to be discussed here is Lapointe's (1980) unspecified-category rule. Each of these is taken up briefly below and then compared to the sort of analysis just proposed here.

Ross's Scrambling Rule as formulated for Latin is cast within the Aspects model of transformational grammar.

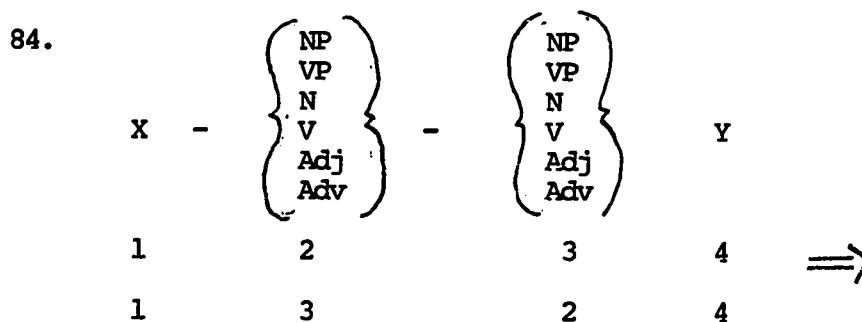

Condition:  $S_i$  dominates 2 if  $S_i$  dominates 3

Such rules, as Ross points out, have some properties which set them apart from the more familiar types of transformations. They can apply an indefinite number of times and, hence, are much more powerful than the familiar transformations. The analysis proposed here does not result in potentially infinite derivations of this sort (although it takes a great deal of pencil and paper to figure that out). A second difference setting scrambling rules apart is that they result in unspecifiable constituent structures. It should be apparent that the present analysis insures completely specified constituent structures. Another possible objection that a scrambling rule for Latin, in particular, is subject to, is that the fact that all subject NPs of a tensed verb must be marked in the nominative case is not accounted for. Within the same tradition, specifically, within the Revised Extended Standard Theory, this objection is overcome since scrambling rules take place after both transformations of the usual sort and logical form, so that the grammatical relations (and, hence, case marking) can be kept straight. In the framework being considered here, however, grammatical relations are defined both syntactically and semantically because of the nature of the rules. Without going into details, it is presumed that this framework would not have difficulty in capturing this fact about Latin syntax because grammatical relations are defined by the semantics for every syntactic rule regardless of order.



It is not clear what sort of scrambling rule within the transformational paradigm could account for the Makua facts without providing a complete analysis within that paradigm. It is worthwhile, however, to investigate briefly the sort of scrambling rule that could be written within the present phrase structure grammar, and, to discuss whether or not such an approach for Makua would work. First of all, a possible scrambling rule within the present framework might be that in (85) below.

$$85. \langle n, [\gamma X \alpha \beta Y] \dots \rangle \Rightarrow \langle n, [\gamma X \beta \alpha Y] \rangle$$

where  $\alpha, \beta, \gamma \in \{V_N \cup V_T\}$

One could, by specifying for each particular language what node  $\gamma$  can be (i.e. whether it is true of S, or S and VP, or S, VP, and NP, for example). Now the rules generalized over by this metarule will "scramble" categories only within their constituents. Further rules would be needed to break up constituents, analogous to the metarule relating VPs to sentences without VPs in Makua. A plausible diachronic scenario then, for ways in which a language with fixed order arrives at free order, is that the change is a gradual one in which the number of constituents allowed to be free becomes greater and greater until the scrambling rule applies to the most general set of categories possible. Rules "destroying" constituent structure such as the V-Initial rule for Makua could likewise become more and more general. Thus totally free order languages are not formally different from fixed order ones in this scenario, they simply have generalized certain related structures to a greater degree.

"Scrambling" within the present phrase structure grammar is not subject to the same criticisms that a scrambling rule within the transformational paradigm is. Depending on the formulation of the rules for the specific language, the use of a PS or scrambling rule will not predict an infinite

set of rules. Because a PS or scrambling rule is defined for each category that it operates on, no unspecified constituent structures will be created.

The next question is whether Makua has any evidence in favor of a rule as general as that in (85) above. First of all, since the NPs are fixed, no such rule could be a generalization about NPs. Secondly, since the total number of categories within the VP (e.g. NP, V,  $\overline{VP}$ ,  $\overline{S}$  etc.) do not appear with total freedom (e.g.  $\overline{S}$ , for example does not precede the verb) this rule would not apply at that level either. Thus, any general "scrambling" rule would be unworkable for Makua. It remains to be seen whether such an approach would say anything interesting about the syntax of Latin, for example, or Walbiri.

Another more recent approach to free word order languages is that proposed by Hale (1979). Hale, when confronted with Walbiri, has proposed that there is a typological dichotomy between languages which can be analyzed in terms of  $\overline{X}$  conventions and those which he calls  $W^*$  languages. The syntax of  $W^*$  languages consists of just a categorial rule of the following sort:

86.  $E \rightarrow W^*$

where E is the category of expressions and W is the category of words. The semantics then has a lot to do. Translation operations operating on the basis of morphological forms of words (which are marked by a feature system of what Hale terms categorial signatures) form semantic constituents. It is not at all clear how this approach would work for Makua (if it would work at all) since Makua nouns are not case marked and there would be no way for the semantics to pick out subjects and objects based on constituents. One could imagine an analysis within Hale's system, which made use of the verb agreement morphology and simply gave two (or three in the case of double object constructions) translations in which the verb agreement was insuffi-

cient to determine which NP was the subject and which NP was the object. It is hard to imagine how such a treatment would account for unbounded dependencies, for example, or the few constraints on order that there are.

Hale's analysis of  $W^*$  languages avoids the three objections to a scrambling rule. Even though the categorial rule would concatenate an infinite number of words, the semantics would presumably constrain the possible combinations of words so that a sentence can have only a finite number of NPs or verbs. In the analysis entertained in this chapter, the fact that a well-formed Makua sentence contains just one verb is a syntactic fact, not just a semantic one. The categorial rule also does not provide for indeterminate constituent structure as the scrambling rule does, because there isn't any constituent structure. Generalizations about case marking will presumably fall out of the semantics, and not the syntax. However, it is clearly preferable on methodological grounds to try to provide an analysis which does not claim that languages are of two fundamentally different types.

Lapointe's (1980) treatment of free word order comes closer to Hale's categorial rule than to Ross's scrambling rule. Briefly, Lapointe proposes that S-expansion rules can be of two sorts, the fixed-category type, where categories are generated in a fixed order by familiar sorts of phrase structure rules in the  $\bar{X}$  convention, and unspecified-category rules, which take either form in (87) below.<sup>11</sup>

87. a.  $S \rightarrow X^*$   
 b.  $S \rightarrow (X^i)^*$

The first rule will concatenate any category at the lexical level in any order. The second rule can limit the categories which can be concatenated. Lapointe suggests that languages might differ with respect to which kinds of S-expansion rules they have. Some languages might have only fixed-category

rules (e.g. English). Others might have both (e.g. Latin) and still others only unspecified-category rules. While Walbiri, which has only a few constraints on order might be thought to fall into this category, Lapointe suggests that even it might have some fixed category S-expansion rules. Thus, Lapointe does not envision a rigid typological dichotomy as Hale does, but rather, as he points out, a graded system.

Another difference that Lapointe indicates is that Hale's  $W^*$  languages do not have an unmarked (i.e. basic order) while any languages having any fixed-category rules do. The justification for including an unmarked order is largely speculative, based on observations about the utility of a basic order for language acquisition and parsing. In the framework being explored for Makua, the distinction between a basic and a non-basic order is not entirely clear cut as it turns out. A discussion of this point is deferred until the last chapter.

Like Hale's analysis, Lapointe's proposal avoids some of the criticisms that can be levelled against a scrambling rule within a transformational paradigm. Although the unspecified category rule will concatenate endless numbers of categories, only certain combinations will get a semantic translation. Constituent structure will not be unspecified, although if an unspecified category rule is used, little constituent structure is present. Finally, since Lapointe's analysis is specifically designed to treat case marking, the Latin generalizations are captured.

Without going into a full analysis of Makua within Lapointe's framework, it is not possible to give any detailed comparison. Nevertheless, it is possible to point out some gross differences between the three approaches outlined above and the analysis presented here. All three of the alternatives just mentioned have one feature in common. That is, each of the analyses adds

a formal device which, in the end, claims that the languages using such devices are different from those that don't in some fundamental way. The analysis proposed here is completely within the formal domain of the framework being investigated. Makua differs (possibly) from other languages like English only in the number of rules (not the kind of rules) and even that is not clear. A second crucial difference is that both Hale and Lapointe make use of a great deal of semantic filtering, that is, strings of categories are generated by the syntax as grammatical and then ruled out by the semantics (i.e. they fail to receive a translation). With the possible exception of the interaction of the tense and aspect with the syntax alluded to in Chapter II, no such semantic filtering is done in this system. While it is always possible that languages could differ along the lines put forth in the alternatives just discussed, it is just as possible that they don't. Makua, at least, doesn't seem to be necessarily different in kind from English within the framework being explored here. Only a thorough analysis of languages like Walbiri within the present framework would provide evidence whether free order languages are the same or different typologically from fixed order languages.

## NOTES

<sup>1</sup>The rules in (2a) and (2b) make additional different predictions regarding possible orders. (2a) but not (2b) will predict the order SVXO because objects could also appear on the right. This order is illustrated in the abbreviated tree below.

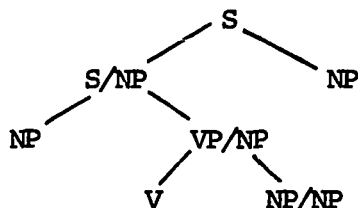

The metarule in (2b), on the other hand, does not affect the order of object NPs.

<sup>2</sup>As Gazdar (personal communication) has pointed out, there is a straightforward sense in which the derived rule schema is a metarule.

<sup>3</sup>The requirement of distinct semantic translations also rules out a rule schema analysis collapsing syntactic features to a single rule of the sort utilized by Gazdar, Pullum, and Sag (1980) in their analysis of the English auxiliary system.

<sup>4</sup>There is another analysis of infinitive complements (suggested to me by Gazdar (personal communication)) which deserves attention. The present analysis claims that infinitive phrases are special instances of verb phrases. Infinitives, in turn, are treated as special kinds of verbs. Thus one would expect that they exhibit verb-like behavior. This claim is borne out by the fact that they can be modified by adverbs. Object agreement is likewise a feature of verbs. The lack of subject agreement could be viewed as just part of the special nature of infinitive phrases. In addition to such verb-like properties, they also exhibit noun-like properties. First, the infinitive prefix *u-* is traditionally treated as one of the noun-class prefixes. Secondly, infinitive phrases may function as the subject or object of a verb. Thus, there is both morphological and syntactic evidence that infinitives are both nominal and verbal.

These facts are suggestive of an analysis in which infinitive phrases are nominalized. A rule of the sort in (a) below will claim that infinitive phrases can be either instances of verb phrases or noun phrases (due to the inherent optionality captured by metarules).

$$(a) \quad \begin{array}{l} [_{VP} \quad V \ X] \\ [+inf] \end{array} \implies [_{NP} \quad V \ X]$$

All features on the infinitive input will be predicted to carry over to the output, e.g. the [+inf] feature. What I have not resolved to my satisfaction is the  $\bar{X}$  level of the nominalized infinitive, whether it should be NP ( $\bar{N}$ ) or Nom ( $\bar{N}$ ). I simply do not have the evidence to decide. According to the

analysis of noun phrases to be discussed in Chapter VI, one would expect that if they are Nom rather than NP, then they could be modified by demonstratives. Cross-categorial generalizations expressed by  $\bar{X}$  would lead one to expect that if they are instances of VP( $\bar{V}$ ) at some level of analysis then they are Nom ( $\bar{N}$ ). However, this need not be the case. In spite of the lack of evidence, however, the nominalization analysis of infinitive phrases makes some very interesting predictions with regard to word order in Makua. That is, when the infinitive phrases have nominal characteristics they have distributional characteristics of NPs. When they have verbal characteristics, their distribution is different. I will continue to explore this analysis in footnotes at relevant points in the text.

<sup>5</sup>The constructions in which the object of the infinitive triggers agreement both on the infinitive and the main verb are not unattested in other Bantu languages. Kisseberth (personal communication) has found similar sorts of constructions in Chinwini and Kiamu. However, he has pointed out that in these languages, which have a much more rigidly fixed order than Makua, the object need not be next to the verb in order to trigger object agreement. Thus, it may be inappropriate even for Makua to claim that the gapped NP is next to the verb. It certainly may be next to the verb in Makua but because of the order variations there is nothing yet to suggest anything about this order.

Note in addition that there is a precedent for the rule in (36) in English, the AP rule one would need for tough-movement cases.

<sup>6</sup>Makua, like many other Bantu languages, does not have a great many adverbs. So far I have not uncovered any that are not related morphologically either to adjectives or to infinitives. Thus, the adverb yakaani-yakaani 'slowly' is related to the adjective yakaani 'slow'. The word rata can be used as an adverb meaning 'well' or an adjective meaning 'good'. In this case, only the order will distinguish which is meant. Since adjectives always follow their nouns (no order change is allowed), rata following a noun is taken to be an adjective if possible, an adverb otherwise. Its reduplicated form ratarata 'carefully' has only an adverbial usage. How productive this reduplication process is is not known. A clearly productive way of making adverbs is the prefixing of va- to the infinitive form. Thus, vohipica 'shortly, before long' is related to uhipica 'to not delay'. A second fairly productive form is prefixing woo to the verb stem (this could be analyzed as u + a + infinitive (which has itself an u- prefix) according to vowel coalescence rules in the language but I am undecided about that). Thus wohulumaca 'quietly, without talking' is related to the verb uhulumaca 'to not talk'. In my sample, all adverbs of the reduplicated sort behave as VP adverbs and all adverbs of the latter two sorts behave as sentence adverbs but it is not known if this is a valid generalization or not.

<sup>7</sup>Note that VP/ $\bar{VP}$  would be a violation of the A over A constraint if that were to be imposed. Certainly noun phrases are inviolable. One cannot, for example, relativize out of a noun phrase containing a relative clause. If,

however, infinitive phrases can also be instances of NP, then the extraction of infinitive phrases could be subsumed under VP/NP. That this is probably correct will be substantiated at later points.

This analysis also raises the question whether PP should likewise be analyzed as an instance of NP. I think that this is not unintuitive but I lack crucial evidence.

<sup>8</sup>Since constituent questions in many languages seem to have syntactic gaps, it is reasonable to ask how such constructions behave in Makua. While my analysis is not complete, it seems probable that constituent questions do not involve gaps. This is because constituent question words are always right in the syntactic position assigned to that constituent being questioned by the basic rules while they are not always right in other places. When they appear elsewhere, they seem to follow the rules applicable to the questioned constituent. Thus, the question words for NPs 'who' apani and 'what' isiensi are positioned like the NPs they substitute for. In addition to the examples given in (45) in Chapter III which showed the behavior of constituent questions in matrix clauses, the example below shows that a question word can remain in an embedded clause (such a question is not, apparently, an echo question). Likewise, the question word for the subject of the embedded clause can precede the matrix sentence parallel to the position of a non-question word NP (along the lines of the S-Topicalization rule to be discussed shortly). So it seems plausible that question words for NP are just a special kind of NP that should receive a unique semantic translation.

(a) Araárima weéríh-a wiirá apání aarweélé  
Araarima sa/t/think-t that who sa/t/go/t  
'Who was it that Araarima thinks left?'

(b) Apání Araárima weériha wiirá aarweélé  
'Who does Araarima think left?'

Their syntax, on the other hand, involves no syntactic gap. The upshot of this is that such structures are not available for testing the appearance of doubly-slashed categories.

<sup>9</sup>Note that the rule [ $\bar{S}$  S/NP NP] rule is not parallel to the S-Topicalization rule in that it does not apply to the categories PP and  $\bar{VP}$ . According to the tests developed in this section, this appears to be correct. Neither  $\bar{VP}$  nor PP are very good in examples parallel to the grammatical (59) and (61a) (62) with NPs. Compare the examples below. In (1a) a  $\bar{VP}$  appears "extracted" out of an embedded clause. In (1b) a PP appears in the same position. The example in (2a and b) show that a  $\bar{VP}$  and PP, respectively, appear following an NP which itself follows a sentential adverb. All are not very good, which indicates that the restriction to NPs is correct. This poses a problem for the analysis of  $\bar{VP}$  as NP. However, I did not test subject infinitives. It remains to be seen if this could be worked out.



<sup>10</sup>It is at this point that the virtues of a nominalization analysis of infinitive phrases (and possibly prepositional phrases) becomes particularly attractive. It could be that the correct characterization of  $\alpha$  in the variable order metarules is simply NP, rather than NP,  $\overline{VP}$ , PP. Then, some different analysis would have to be given for adverbs. Just for the sake of argument, suppose that  $\beta$  is NP in the above rules. That eliminates  $\overline{S}$  from consideration altogether. The metarules will predict that infinitive phrases can appear preverbally only when they are instances of NP, i.e. when they are nominalized. That leaves the distribution of  $\overline{VP}/NP$  to be accounted for. Note however that  $\overline{VP}/NP$  could not be an instance of nominalization (hence, not an NP, if extraction out of noun phrases is generally constrained in the language. For  $\overline{VP}/NP$  to be nominalized would involve a rule  $[\text{NP}/\text{NP} \quad \text{Nom} \quad \text{NP}/\text{NP}]$  violating established principles. If NP/NP is  $[\text{+inf}]$   $[\text{+inf}]$

never an instance of NP it would not fit  $\alpha$  in the metarules and never appear preverbally.

The distribution of categories would then be accounted for. In addition, the somewhat ad hoc character of the variable order metarules is considerably reduced.

Makua would then be an instance of a language that allowed freedom of NP and Adverbs but nothing else.

<sup>11</sup>Subsequent to the wording of his thesis Lapointe revised his analysis of free order rules (Lapointe to appear). For discussion of this revised proposal with respect to Makua see Stucky (1980). The very general comments made with respect to Lapointe's proposal in this thesis still obtain.

## CHAPTER V

## VERB AGREEMENT

## 1. Introduction

In this chapter, the analysis proposed for word order in Makua (in the previous chapter) is extended to include verb agreement. The analysis of verb agreement in this chapter relies on the matching of rule features marking noun classes on NPs to syntactically defined agreement features on verbs, which are correlated with the noun class indicated by the agreement morphemes themselves. In addition to the syntactic features, I make use of the Head Feature Convention as defined by Gazdar (to appear b) which allows agreement to be stated more generally than would otherwise be possible. It is, crucially, the use of the rule features together with the Head Feature Convention which captures the generalizations about verb agreement in Makua, although the analysis of verb agreement requires the addition of no new formal apparatus since both rule features and the Head Feature Convention are devices which are already part of the framework.

The analysis of verb agreement developed in this chapter accounts for obligatory subject agreement for all classes of verbs, and agreement of the applied object and causee of the bitransitive verbs discussed in Chapter IV. In addition, the extension of the formalism predicts the restricted verb agreement with the direct object NP of bitransitive verbs in such a way as to sharply differentiate between orders induced by the basic rules and metarules from those based on the derived rules and linking rules, providing additional support for the formulation of the specific rules in Chapter IV.

The chapter is set out as follows. Section 2 includes a discussion of the facts to be accounted for, along with the formulation of the rule features for agreement which are tied to the set of basic rules discussed in Chapter IV. The third section of this chapter shows how these verb agreement features interact with the metarules. Section 4 treats verb agreement for derived rules and linking rules. In the final section (Section 5) the implications of this treatment for both the analysis presented and the more general question of a basic syntactic word order are discussed.

## 2. The facts and the rule feature schema

### 2.1 The facts

The facts to be accounted for include subject and object agreement with overt subject and object NPs in the constructions presented in Chapter IV. As in previous discussion, sentences without overt subjects and object NPs are not treated.

A Makua verb will exhibit a subject agreement prefix corresponding to the noun class of the subject NP or, in the case of personal pronouns, a prefix corresponding to person (e.g. first person singular or plural, second person singular or plural initiated, second person singular or plural uninitiated, third person singular or plural initiated, and third person singular or plural uninitiated). While this phenomenon could be observed in all the examples thus far, I will point out once again exactly what to look for morphologically. In the examples in (1-3) below, the tense/aspect morpheme following the subject agreement prefix is consonant initial so that subject agreement can be observed in its underlying form. The subject noun is nivaka 'spear', a class 5 noun. In this case the subject agreement prefix is ni- as well.

1. ni-váká ni-ho-ńth<sup>h</sup>yá-a  
 pref-spear sa-t/a-break-t/a  
 '(the) spear is broken'

In (2) below the subject noun is ihípá 'hoe/hoes' which could be either a Class 9 or a Class 10 noun in isolation. The subject agreement form here is ci- however, indicating that ihípá is to be taken in the plural.

2. i-hipá ci-ho-ńth<sup>h</sup>yá-a  
 pref-hoe sa-t/a-break-t/a  
 '(the) hoes are broken'

In (3) the subject NP is of Class 1a and there is no overt subject agreement marker present.

3. ∅-báásikeli ∅-ho-ńth<sup>h</sup>yá-a  
 pref-bicycle sa-t/a-break-t/a  
 '(the) bicycle is broken'

The morphological non-identity of the noun class prefix and corresponding subject agreement prefix in examples like that in (2) precludes any analysis which rests on a simple morphological copying process. Something also needs to be said about the lack of the subject agreement prefix for Class 1a nouns (the lack of morphemes is true of third person singular personal pronouns as well). As far as I can tell, it makes no difference to the analysis whether a ∅ morpheme with no phonological shape is assumed or whether the verb has no agreement morpheme at all as long as the verb is marked with its syntactic agreement feature (it could be the case that a formal treatment of the morphology, which I have not attempted here, would choose between the two approaches). In any event, there is no phonological or tonological process (that I am aware of) which is sensitive to the appearance of some abstract morpheme.

While it is generally true that a verb can agree with what is semantically

the subject NP in any sentence regardless of word order, there are two instances in which what is a non-subject NP semantically may, optionally, trigger subject agreement. These two very interesting cases are taken up separately, one in Section 3 of this chapter and the other in Chapter VI. The analysis of verb agreement here insures only that the noun class of the semantic subject NP triggers verb agreement.

Objects, like subjects, also trigger verb agreement, but the facts in this case are much more complicated. I will begin first by discussing object agreement of transitive verbs (including causative and applied forms of basically intransitive verbs). Then I will take up the bitransitive verbs.

Object agreement prefixes, as noted in Chapter II, show up between the tense and aspect prefixes and the verb stem. Recall that for purposes of tone assignment in *Imit<sup>h</sup>upi*, object prefixes behave as part of the root. Like the subject prefixes, the object prefixes cannot be identical copies of the noun class prefix since, for example, the object agreement morpheme for Class 1a nouns (that have no prefix themselves) is mu- (which alternates with a nasal consonant before consonant-initial stems). There are object prefix morphemes only for personal pronouns and Class 1, 1a and 2 nouns. There are no object agreement morphemes for all the other classes. Again, the question arises as to whether there should be a  $\emptyset$  morpheme in the instances where no overt morpheme appears. As in the case of the missing subject prefixes, there is (as far as I know) no phonological or tonological rule sensitive to the positions in which gaps in morphology occur, so that a  $\emptyset$  morpheme would not be necessary at least. So long as verbs have some rule agreement feature, the analysis proposed here will work.

Leaving aside cases in which no overt object NP appears (see the examples in (9) and (10) in Chapter II for some discussion of the anaphoric and indefi-

nite referential functions of the object prefix), the facts are that overt object NP or personal pronoun will trigger obligatory object agreement when the verb is transitive. This is true not only of basically transitive verbs but derived transitive verbs (i.e. the causative and the applied) as well. The examples in (4) below show how this works. The sentences in these examples would be ungrammatical without object agreement (just as they would be ungrammatical without subject agreement). Significantly, any of the six possible permutations of the three words in each sentence will also require object agreement.

4. a. Araárima a-ho-n<sup>h</sup>-th<sup>h</sup>úm-a báásikeli  
 Araarima sa-t-oa-buy-t/a bicycle  
 'Araarima has bought a bicycle (1a)'
- b. Araárima a-haa<sup>h</sup>-th<sup>h</sup>úm-a á-báásikeli  
 Araarima sa-t/a/oa-buy-t/a bicycles  
 'Araarima has bought bicycles'

One generalization to be captured, then, is that a single NP object of a transitive verb (regardless of whether it is a basically transitive verb or a derived transitive verb) will trigger agreement.

Agreement facts for the bitransitive verbs are more complicated. Consider first the causee of a derived bitransitive verb and the applied object of a derived bitransitive verb when that applied object is a recipient, a beneficiary, or a locative (but not, crucially, when it is an instrumental). When an object of that group is of an agreeing class (i.e. a personal pronoun, or a noun of Classes 1a, 1, or 2) then verb agreement is with that object regardless of word order. Thus, in the following example, the subject NP is the pronoun mii 'I', the applied object is a beneficiary of Class 2 and the direct object is of Class 1. In this case there is an object agreement form for both the objects (e.g. mu- for Class 1a and -a- for Class 2). When the agreement prefix is that for Class 1a, only the reading in which the Class 1 noun is the applied object

is allowed, regardless of order. When the agreement is with the Class 2 noun, on the other hand, the reading is reversed, again, regardless of order (that Class 2 noun is taken to be the applied object). Compare the examples in (5a) and (5b) below.

5. a. mii ki-ho-n-th<sup>h</sup>um-el-a amirawo baasikeli  
 I sa-t/a-oa-buy-app-t/a boys bicycle  
 'I have bought the boys for the bicycle'  
 (obviously an unlikely situation)
- b. mii ki-haa-th<sup>h</sup>um-el-a baasikeli amirawo  
 I sa-t/a-oa-buy-app-t/a bicycle boys  
 'I have bought the bicycle for the boys'

These facts also hold for recipient applied objects, locative applied objects and causees. The really tricky cases are ones in which one of the objects is of an agreeing class but the other is not.

One might expect, on the basis of the evidence in (5), that overt agreement with one of the NP objects would insure that the reading is always one in which the object agreed with is the beneficiary, since it is the case in examples like (5) that it is the applied object which triggers agreement (and not the direct object). This is not the case. In the examples in (6) below, there is only one object NP which has an agreement morpheme (unlike the examples in (5) in which both NPs had an agreement morphemes associated with them). In the examples in (6), the noun baasikeli 'bicycle' is of Class 1a and has associated with it the object prefix form mu- (which surfaces in this example as a nasal consonant). Ntenga 'messenger', on the other hand, is a Class 3 noun and it has no overt agreement prefix correlated with it. It turns out that in a subset of the orders, the reading with object agreement can be that of the direct object and not the applied object. Compare the examples in (6). In (6a) there is agreement with the Class 1a noun, baasikeli 'bicycle' and the reading is the less likely one in which the messenger was bought for the bicycle. In (6b), the word order is different but the

agreement facts are the same, and, importantly, the reading changes.

6. a. míi ki-ho-ń-th<sup>h</sup>úm-él-á nténgá báásikely-ule  
 I sa-t/a-oa-buy-app-t/a messenger bicycle-dem  
 'I bought a messenger for the bicycle'  
 (and not I bought a bicycle for the messenger)
- b. báásikely-úlé míi ki-ho-ń-thúm-él-á ntenga  
 'The bicycle I bought for the messenger'

Thus, under certain conditions, either an applied object or a direct object can trigger object agreement. The facts about this second agreement strategy are taken up in Section 4 of this chapter in conjunction with the analysis of agreement for derived and linking rules.

The facts with respect to object agreement for instrumentals are different. In this case, either the instrument or the direct object can trigger agreement in the order S V Inst. DO (unlike the agreement facts for the beneficiary applied in the examples in (6)). The tendency is for agreement to be with the direct object rather than the instrument (i.e. applied object), although, in principle, a sentence like that in (7) is ambiguous because the two objects are of the same noun class.

7. míi káhó-móópoh-ér-á havará mwaána  
 I sa/t/a-oa/threaten-app-t/a leopard child  
 1) I used a leopard to frighten a child  
 2) I used a child to frighten a leopard

There is then, some slight indication that word order has an effect on agreement strategies. Rather than present all the details regarding this interaction of order and agreement at this point, I will take them up in the course of the analysis where they will be easier to remember. The analysis, then, will have to account for subject agreement in all clause types, object agreement with transitive verbs, and object agreement of various types with bitransitive verbs.



## 2.2 The analysis - Verb agreement and the basic rules

In this section the analysis proposed for word order in Chapter IV is enriched by the use of two formal devices in order to account for verb agreement. These two devices, already employed in the analysis for phenomena other than agreement, are the Head Feature Convention and rule features.

First, I am assuming a finite set of features on nouns which, for their mnemonic value, are the numbers traditionally associated with the noun classes, eg. [1a] for Class 1a nouns, [5] for Class 5 nouns. Such features are associated with the lexical entry for nouns (although I am not making precise how this is to take place formally here). Thus, pre-terminal symbols will include such features.

In addition, a new type of syntactic feature for verbs will be employed. The formulation of this version of the feature I owe to Ivan Sag. This new feature will be a singleton set whose only member is an ordered pair. The first member of the ordered pair will represent an agreement feature from the same set of numbers used for the noun classes and it signals subject agreement. The second member of the ordered pair is also a noun class feature from the same set, but it corresponds to the object agreement prefix. Like the nouns, verbs have associated with them these syntactic features. There will be, then, features of the following sort: [ $\langle 1, 1 \rangle$ ] (where subject agreement is Class 1 and object agreement is Class 1), [ $\langle 1, 2 \rangle$ ] and [ $\langle 2, 2 \rangle$ ], etc. However, as pointed out above, no attempt to formulate how exactly these features come to be on the verbs is attempted in this analysis. I am assuming the assignment of features takes place in the word formation rules in the lexicon.

In addition to the syntactic features just presented, I will make use of the Head Feature Convention which insures that the features on a phrase

level node are the same as those on the head of that phrase. Its utility will become apparent when the agreement schemata are proposed. Here is the formal definition of the Head Feature Convention (henceforth HFC).

8. "HFC: In a rule of the form  $D \rightarrow \dots\delta\dots$  where  $\delta$  is the head of  $D$ ,  $\delta$  carries all the features associated with  $D$ ."

(Gazdar: to appear b:7)

I now define "head of" informally so that (for purposes of this thesis) VP is the head of S, V is the head of VP, Nom is the head of NP, and N is the head of Nom. (See Gazdar to appear b:7 for a formal definition of "head of".)

The HFC insures that features are percolated down the tree. That is, features would need only be specified on S, for example; they would subsequently be passed down to the VP and to the V by convention. But, in spite of the fact that VP is defined as the head of S, the present analysis, for the most part, does not make use of this relationship. Rather, agreement features are specified on the VP. I have chosen this approach for two reasons. One is that the analysis works out better this way for the interaction of the metarules. This evidence will become clearer as the analysis progresses. The second reason is that if, instead of defining agreement at the VP level, agreement is defined at the S level, then it becomes cumbersome to account for the differences in agreement for intransitive, transitive and bitransitive verb phrases. The difficulty arises because, in Makua, agreement facts are different for each of the types of verb phrase. These differences seem properly attributable to the verb phrase rather than the sentence, and it is straightforward to pick out intransitive VPs from transitive VPs, for example, according to the subcategorization facts associated with those verbs in each of the rule types. It will be easier to discuss the particular consequences after some part of the analysis is presented, so that I will come back to

this point shortly.

Taking the features of the sort defined above for nouns and verb agreement, these are incorporated into two of the basic rules as in (9) below. These revised rules taken together with the HFC will insure that the features postulated for the NP and the VP will be percolated onto their respective heads, Nom and V.

9. a. 4, [  $\begin{matrix} S & NP & VP \\ & [\alpha] & [<\alpha, \beta>] \end{matrix} \ ] \dots$  where  $\alpha, \beta \in \{1, 1a, 2, 3, \text{persons}; 1st, 2nd, \text{etc.}\}$
- b. 3, [  $\begin{matrix} VP & V & NP \\ & [<\alpha, \beta>] & [\beta] \end{matrix} \ ] \dots$  where  $\alpha, \beta \in \{1, 1a, 2 \dots\}$

As Gazdar (to appear b) points out, this approach eliminates the need for copying rules which involve hunting for the subject and the verb and then copying the features. Instead, the features are already there, and the rule features simply insure that these features match. It is worthwhile noting that the incorporation of the features directly into the rules will make agreement obligatory (because a sentence will be well-formed only if there is agreement and only if the features match) in just the way required.

The agreement schema in (9) together with the HFC will analyze a partial tree like that in (10a) below because the features match. They will not analyze a partial tree like that in (10b), because the features in that tree do not correlate in the manner required by the agreement schema. Circled features indicate the non-matching features.

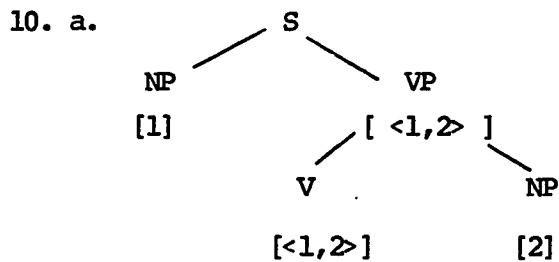

10. b.

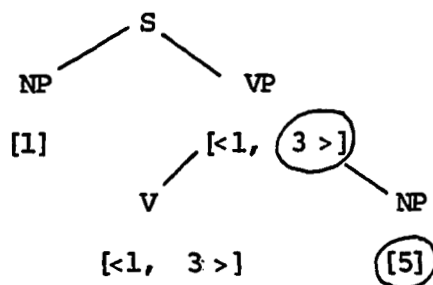

Note that the rule in (9) claims that all verbs, even intransitive verbs have object agreement. At first glance, this might seem to be the wrong claim. Recall, however, that at least some intransitive verbs (e.g. wóóná 'to see') are subcategorized for the rule in (11) below, so that verbs which seem to be basically semantically intransitive do in fact show up with object agreement.

11. [<sub>VP</sub> V NP  $\bar{S}/NP$ ]

For those intransitive verbs that do not exhibit object agreement, I will assume that  $\beta$  in rule (9) above ranges over  $\emptyset$  (the null element) as well. The two patterns in (12) below illustrate how an intransitive verb works. If there is no object for the verb to agree with, the verb phrase node has the feature  $\emptyset$  in it (as in 12a)). In the second case (12b), there is an object NP, and it triggers agreement due to the matching requirement.

12. a.

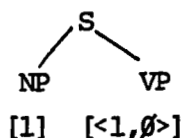

b.

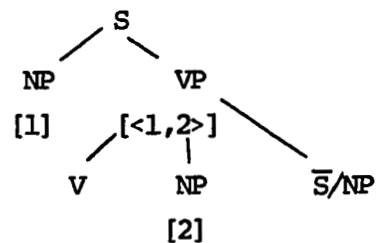

For some of the basic rules, the following extensions are proposed. Most rules are accompanied by an example.

13. a.  $[_S \text{ NP VP }]$   
 $[\alpha] [\langle \alpha, \beta \rangle]$
- b. Aráárima a-ho-ń-túpúl-á serúliya  
 Araarima sa-t/a-oa-cut-a bamboo  
 'Araarima has cut split bamboo'
14. a.  $[_{VP} \text{ V NP}]$   
 $[\langle \alpha, \beta \rangle] [\beta]$
15. a.  $[_{VP} \text{ V }]$   
 $[\langle \alpha, \beta \rangle]$
16. a.  $[_{\overline{VP}} \text{ V }]$   
 $[\langle \alpha, \beta \rangle]$
17. a.  $[_{\overline{VP}} \text{ V NP }]$   
 $[\langle \alpha, \beta \rangle] [\beta]$
- b. Aráárima a-ho-lik-á u-ń-réhelela báásikeli  
 Araarima sa-t/a-try-a. inf-oa-repair bicycle  
 'Araarima has tried to repair a bicycle'
18. a.  $[_{\overline{VP}} \text{ V } \gamma \overline{VP}/\gamma ]$  where  $\gamma \in \{\text{NP}\}$   
 $[\langle \alpha, \beta \rangle] [\beta]$
- b. Aráárima a-ho-ń-líka báásikeli u-ń-réhelela  
 Araarima sa-t/a-oa-try-t/a bicycle inf-oa-repair  
 'Araarima has tried a bicycle to repair'
19. a.  $[_{VP} \text{ V } \overline{S}]$   
 $[\langle \alpha, \beta \rangle]$
- b. Aráárima a-no-th<sup>h</sup>ánán-a wiírá áfúúndí a-ń-réhelel-é  
 Araarima sa-t/a-want-t/a that experts sa-oa-repair-subj  
 báásikely-úlé  
 bicycle  
 'Araarima wants that experts repair the/that bicycle'
20. a.  $[_{VP} \text{ V } \gamma \overline{S}/\gamma ]$   
 $[\langle \alpha, \beta \rangle] [\beta]$   
 where  $\gamma \in \{\text{NP}\}$

20. b. Aráárima a-no-n-thánan-a báásikely-úlé wiirá áfúúndi  
 Araarima sa-t/a-oa-want-t/a bicycle-dem that experts  
 a-n-rehelel-é  
 repair-subj  
 'Araarima wants that bicycle that experts repair (it)'

### 3.0 Metarules and verb agreement

To begin with, the rule schemata for verb agreement will interact with metarules in a straightforward fashion. Since verb agreement has been specified for the basic rules which form the input to the metarules, any syntactic feature, including verb agreement, will automatically be carried over to the output unless specified otherwise. An example will show how this works. Suppose we take the NP Final rule proposed in Chapter IV repeated here as (21).

#### 21. NP Final

$$\langle n, [{}_S \text{ NP X}] \dots \rangle \implies \langle n, [{}_S \text{ X NP}] \dots \rangle$$

One of the inputs to that rule will be  $[{}_S \text{ NP VP}]$ . And without further changes, the output will be predicted to be  $[{}_S \text{ VP NP}]$ , with verb agreement intact, in accordance with the agreement facts. In general, this result (i.e. that verb agreement remains intact) will obtain whenever the category admitted by the input is the same as the category admitted by the output. However, when the category admitted by an input rule is not the same as that admitted by its corresponding output rule, and in particular, if some category is present in the output which is not present in the input, then agreement will be insufficient. Take for example the Verb-Initial rule, repeated here as (22).

## 22. Verb-Initial

$$\langle n, [_{VP} V X] \dots \rangle \implies \langle n, [_{S} V NP X] \dots \rangle$$

One of the input rules to the Verb-Initial rule will be  $[_{VP} \quad V \quad NP]$   
 $[<\alpha, \beta>] \quad [\beta]$

By the Head Feature Convention, the V in that rule will have its features, as will the N. However, the output rule has an "extra NP", the subject, which has no agreement feature. When the agreement feature is added to the "extra NP", one also needs to insure that the verb agrees with the subject. Thus, agreement features will have to be added to the verb as well. If agreement features are not added to the verb, then the possibility arises that the verb will not agree with the subject (or anything else in the sentence, for that matter). This is because one of the input rules will be  $[_{VP} \quad V \quad NP]$   
 $[<\alpha, \beta>] \quad [\beta]$

while the output could be  $[_{VP} \quad V \quad NP \quad NP]$ . This is an undesirable consequence altogether. Thus, the Verb - Initial rule needs to be revised as follows.

## 23. (Revised) Verb-Initial rule

$$\langle n, [_{VP} \quad V \quad X] \dots \rangle \implies \langle n, [_{S} \quad V \quad NP \quad X] \rangle$$

$$[\alpha]$$

Note that this sort of problem could not be alleviated by postulating agreement features at the S level since it would still be necessary to specify either features for the S (taking V to be the head of S), or for the V.

Now either this is a loss of generalization, since agreement must be specified again, or else there should be evidence that this extra specification does some work. In the case of this Verb-Initial structure, there is evidence which suggests separating out just this order for special treatment.

This is because the order OVSX (where X includes a VP adverb, for example) showing that it is indeed the Verb-Initial rule together with S-Topicalization that has created this order, the object NP can, under very limited conditions, trigger both subject agreement and object agreement, while the subject triggers no agreement at all. The conditions under which this happens are related to tense and aspect, as well as to the state of the world being talked about in the sentence. Here are the conditions. When the order is OVSX (as stipulated above) and when the tense and aspect markers are of Set A (as outlined in Chapter II) and when the object NP is in the same state after the action of the verb has been completed, then the subject does not have to trigger subject agreement but the object can. (This alternative agreement pattern may be obligatory but I am not sure.) Thus, compare the examples in (24) below. Eating manioc (in 24a) differs from planting manioc (in 24b) in that the manioc exists in a different state after the completion of the action of the verb. Understanding (25) requires a context. If Hin-Sepete has had the job of stitching up the book then the different agreement patterns have distinct uses. The one in which the object triggers subject agreement (25a), means that the book didn't get stitched (i.e. it remained in the same state). The one with real subject agreement, (25b), implies that it did get stitched (i.e. it changed states).

24. a. nnangwa-nne  $\begin{cases} *aa \\ naa \end{cases}$  -l-il-é \*amiráwo léélo  
           manioc -dem sa/ta-plant-t/a boys today  
           'that manioc was planted by boys today' (not the girls)
- b. nnángwá-ńné  $\begin{cases} aa \\ *naa \end{cases}$  -lil-yé amiráwo léélo  
           'that manioc was eaten by the boys today' (not the girls)



25.  $\left. \begin{matrix} \{a\} \\ \{i\} \end{matrix} \right\} - \text{malih-iré } \acute{a}m\acute{u}n\acute{n}\acute{a}$   
 book-dem      sa-finish-t/a      brother  
 1) (sub. ag. with  $\acute{a}m\acute{u}n\acute{n}\acute{a}$ )  
     'the book my brother has finished with' (i.e. finished stitching it)  
 2) (sub. ag. with ikitaábu)  
     'the book my brother has finished with it' (he's given up stitching it and has given it to someone else to finish)

Admittedly, the conditions under which the object can trigger this "funny" agreement are not entirely syntactic, since there is an interaction of tense/aspect morphology and the state of the world. The usurpation of subject agreement by a topicalized object is attested in other languages. Keach (1980) treats a similar, albeit much more general phenomenon, for a dialect of Swahili. But it is important for the analysis of Makua that it is this order and this order alone, one in which there is no syntactic verb phrase, in which the agreement patterns are different. Ultimately, this order will have to be singled out for special treatment. Thus, the separate specification is not as arbitrary as it first appears. I will not attempt to specify this alternative agreement pattern here, in part because it involves interactions with other rules and in part because this sort of semantic and pragmatic interaction is just the one alluded to at the end of the second chapter which is simply beyond the scope of the thesis. I bring forward the evidence just to suggest that the apparent loss of generalization in the agreement schemata for metarules is not as bad as it first appears.

There is a second metarule which has the same potential problems. This is the Variable Order S rule here repeated and modified as (26).

$$26. \langle n, [_{VP} \quad X \quad V \quad Y], \dots \rangle \Rightarrow \langle n, [_{S} \quad X \quad \begin{matrix} NP \\ [\alpha] \end{matrix} \quad V \quad Y], \dots \rangle$$

Again, the agreement for the subject will have to be fully specified, but in

this case I have no evidence to bring forward in support of this.

Finally, there are the additional cases, analogous to the instances just discussed, in which the output of a metarule contains an element not present in the input. These involve the metarules relating non-applied or non-causative verbs to their derived counterparts. Part of the motivation for separate rules, rather than a single rule, [<sub>VP</sub> V NP NP], was semantic, i.e. it was suggested that a sophisticated semantics would want to distinguish an instrument, say, from a causee. At that point it was also suggested that there were syntactic differences which supported the multi-rule approach, namely, that agreement facts for the beneficiary and instrumental applied objects differed. I will now demonstrate how these rules interact with agreement features.

As presently formulated the agreement schemata as defined for the basic rules will interact with the metarules introducing the derived verbs to predict the wrong results. Consider one of these metarules in (27) below.

$$27. \langle n, [\substack{\text{VP} \\ [-\text{app}] \\ [-\text{ben}]} \quad V \quad X], \dots \rangle \implies \langle n, [\substack{\text{VP} \\ [+app] \\ [+ben]} \quad V \quad NP \quad X], \dots \rangle$$

Now one of the input rules will be that in (28a) below and its corresponding output is claimed to be (28b). That output rule has no provision for agreement of the object.

$$28. \quad \begin{array}{ll} \text{a. } [\substack{\text{VP} \\ [<\alpha, \beta>] \\ [-\text{app}] \\ [-\text{ben}]} \quad V] & \text{b. } [\substack{\text{VP} \\ [<\alpha, \beta>] \\ [+app] \\ [+ben]} \quad V \quad NP] \end{array}$$

A similar problem holds for the bitransitive verb phrases, where the one of the input rules will be as in (29a) and the output will be (29b).

The output rule does have agreement specified both for the VP (and the V by the HFC) and an NP but it is the wrong NP, the direct object.

29. a.  $[_{VP} \quad V \quad NP ]$                       b.  $[_{VP} \quad V \quad NP \quad NP ]$   
            $[\langle \alpha, \beta \rangle]$                                        $[\langle \alpha, \beta \rangle]$   
            $[-app]$      $[-app]$   
            $[-ben]$      $[-ben]$

The incorrect predictions of the metarule introducing derived VPs can be eradicated by amending the rule as in (30) below, which insures that the output has agreement with the derived "extra" NP and that the VP has two agreement features.

30. (Revised) Derived VP Metarule

- $$n, [_{VP} \quad V \quad X ] \dots \implies n, [_{VP} \quad V \quad NP \quad X ]$$
- $[\langle \alpha, \beta \rangle]$      $[\langle \alpha, \gamma \rangle]$   
 $[-app]$      $[-app]$   
 $[-ben]$      $[-ben]$

The correct interactions are now insured. First, the basically intransitive VPs will have the required agreement features on the derived VP. The input rule  $[_{VP} \quad V ]$ , for example, will now have  $[_{VP} \quad V \quad NP ]$  as its corresponding output insuring agreement of the "extra object". A basically transitive VP, will, according to the amended metarule have as an input rule

- $$[_{VP} \quad V \quad NP ] \text{ which is now correctly the related rule } [_{VP} \quad V \quad NP \quad NP ]$$
- $[\langle \alpha, \beta \rangle]$                                        $[\langle \alpha, \gamma \rangle]$                        $[\gamma]$                        $[\beta]$

in which it is the extra "NP" which triggers object agreement in accordance with the facts. Recall from the introductory discussion in Section 2.1. in this chapter, that it is the applied object and not the DO which gets agreement (in this order S V AO DO). The rules introducing the causative, the applied beneficiary and recipient will have to be revised in this fashion. But since the instrumental applied behaves differently, something else will

have to be done. Thus, the amended rules will account for the examples in (31) below in which it is the "extra" NP which gets agreement.

31. a. Aráárima á-hó-ń - hókolyeéh-á mwaán-ólé  
 Araarima sa-t -oa-return/caus-t child-dem  
 'Araarima caused the child to return'
- b. Aráárima á-hó-ń - hál-él-á mwaánólé  
 Araarima sa-t -o -wait-app-t child-dem  
 'Araarima has waited for the child'
- c. Aráárima á-háá-háandik-ih-á mwaárimw-aáyá ibáruwa  
 Araarima sa-t -oa write-caus-t teacher-poss letter  
 'Araarima made his teacher write a letter'
- d. Aráárima á-háá-rwéeh-él-á mwaárimw-aáyá ibáruwa  
 Araarima sa-t -o - send -app-t teacher-poss letter  
 'Araarima wrote a letter to/for his teacher'

The instrumental applied, on the other hand, behaves differently from the cases just discussed. First, there appears to be a related prepositional construction for these cases, as in (32a-b). (32d) shows, in addition, that when the direct object is of an agreeing class (i.e. when there is an agreement prefix available, then the object triggers agreement) and if the instrument is not of an agreeing class then agreement with the direct object is strongly preferred (as opposed to having no agreement at all). On the other hand, as (32c) illustrates, there are two readings, suggesting that either the direct object or the instrument can trigger agreement.

32. a. PP-Inst.  
 mí káhó-móopopih-á mwaána ni-hávára  
 I sa/t-oa/threaten-a child with-leopard  
 'I threatened a child with a leopard'
- b. mí káhó-móopopih-á havára ni-mwáana  
 I sa/t-oa/threaten-t leopard with-child  
 'I threatened a leopard with a child'

- c. míi káhó-móópópih-ér-á mwaáná haváraé  
 I sa/t-oa/threaten-app-t child leopard  
 1) 'I used a leopard to threaten a child'  
 2) 'I used a child to threaten a leopard'
- d. míi káhó-(móó)-popih-ér-á mwaáná nivála  
 I sa/t-oa/threaten-app-t child mouse  
 1) 'I used a mouse to threaten a child'  
 2) 'I used a child to threaten a mouse'

This interaction can be accounted for if the metarule relating the prepositional instruments and the applied is amended to include agreement as follows.

33. a. 
$$\begin{array}{c} [_{VP} \quad V \quad X \quad PP \quad ] \\ \quad \quad \quad [+inst:] \end{array} \Rightarrow \begin{array}{c} [_{VP} \quad V \quad NP \quad X] \\ \quad \quad \quad [\beta] \end{array}$$
- $$\begin{array}{c} [-app] \\ [-inst] \end{array} \quad \begin{array}{c} [+app] \\ [+inst] \end{array}$$

Now it will be the case that the agreement is with the instrument and the

direct object, since one of the input rules will be 
$$[_{VP} \quad V \quad NP \quad PP \quad ]$$
  

$$[\langle \alpha, \beta \rangle] \quad [\beta]$$

to which the corresponding output will be 
$$[_{VP} \quad V \quad NP \quad NP \quad PP]$$
 corresponding  

$$[\langle \alpha, \beta \rangle] \quad [\beta] \quad [\beta]$$

to the facts in example (32b). However, the formulation in (33a) is still not sufficient, for it does not allow the instrument NP to trigger agreement when it is not the same noun class as the direct object NP. In fact it requires that the Object and the instrument be of the same class (because both NPs end up with  $[\beta]$  features). This is because a potential input rule is 
$$[_{VP} \quad V \quad NP \quad ]$$
  

$$[\langle \alpha, \beta \rangle] \quad [\beta]$$

but an output 
$$[_{VP} \quad V \quad NP \quad NP \quad ]$$
 is always ill-formed. Such examples are  

$$[\langle \alpha, \beta \rangle] \quad [\gamma] \quad [\beta]$$

clearly good (as (34a) below illustrates), where the direct object is of class different from the instrumental NP. There is nothing to do but amend this rule once more to account for the optionality.

34. a. Araárima áhó-túpúl-a mwaáló inámá  
 Araarima sa/t-cut-t knife(Cl.3) meat (Cl.9)  
 'Araarima used a knife to cut meat'

34. b. <n, [<sub>VP</sub> V X PP ]> <n, [<sub>VP</sub> V NP X]...>  
           [<α,β>]           [+instr]           [+app]           [+instr]  
           [-app]                                   [+inst]  
           [-instr]

What can be said for this analysis is that it is possible to capture this optionality only because the applied instrumental rule is separated out from the other rules.<sup>1</sup>

Taken together, this agreement analysis thus far doesn't appear to be altogether unified. It was necessary to specify agreement in a number of cases. In one set of cases, it was derivative of the formalism itself. Whenever the metarule did not have the same node admitted in its output as in the input, then agreement had to be respecified. However, there was some evidence internal to Makua (i.e. the Verb-Initial rule) which suggested that this approach might not be unmotivated. In a second set of cases, the interaction of the agreement schema and the metarules made the wrong prediction (i.e. in the case of the derived verbs) so that it was necessary to build agreement into the metarule. Again, it is not entirely clear that this approach is wrong, since it could be utilized to separate out the instrumental applies, for instance, from the other applies.

In addition to the evidence from Makua in favor of such a non-unified approach to agreement, there is, among other Bantu languages, at least, evidence that such special differences in agreement patterns is typical. For instance, in Tshiluba, a Bantu language of Zaire, there is verb agreement not only with direct objects in the derived bitransitive verbs, but with the applied objects and causees as well. There is even a third object agreement position in that language for locatives. The interaction of agreement in this case I discovered is extremely complicated and, if a syntactic account were to be given of the sort here, then all the separate rules would be useful.

In fact, the differences in behavior of the various semantic classes of objects of the applied verbs is not uncommon either (e.g. Chinwini, Kisseberth and Abasheikh (1977)). What I am suggesting then, is agreement phenomena are to some extent variable among even the Bantu languages and the freedom of this approach makes it possible to make precise details of agreement from language to language. It remains to be seen whether this approach will work in general and whether the missing claim, that is, that a verb must have agreement is a valid criticism. The question does arise, of course, if one did discover a language with completely regular agreement whether this sort of approach could make any generalizations to that effect. First, it should be noted that the way in which I formulated agreement is not the only possibility available.<sup>2</sup> Secondly, each language would have to be examined on its own merits in order to see what the analysis for that language ought to be. Thus, any conclusion about the framework is not well justified at this point. Certainly I do not wish to imply that it is this framework which forces a non-unified analysis. Fully explicit accounts of verb agreement (down to all the idiosyncratic details) are rarely given in any paradigm.

#### 4. Derived rules, linking rules, and agreement schemata

There are several questions to be addressed in defining agreement schemata for the derived rules and the linking rules. One revolves around the interaction of the agreement schemata (as defined for the basic rules) and the derived rule schema itself. The second question is raised by the fact that linking rules and derived rules are separate rules and, hence, require separate statements for agreement. In addition, what appears to be a lack of generalization turns out to be just the point in the grammar at which Makua morphology behaves differently, so that the apparent lack of generalization again

works in favor of the analysis for Makua. I will begin by taking up each of these formal issues separately, showing why they are potentially problematic and then, show how those problems can be resolved.

The derived rule schema, recall, relates basic rules and derived rules in such a way as to keep syntactic features intact. Since agreement has been defined in terms of syntactic features on the basic rules, these features too will automatically be carried over. Thus, for the Basic rule in (35a) below, there will be the following derived rule in (35b).

35. a. 
$$\left[ \begin{array}{cc} S & VP \\ \alpha & \langle \alpha, \beta \rangle \end{array} \right]$$
- b. 
$$\left[ \begin{array}{ccc} S/NP & NP & VP/NP \\ \gamma & \alpha & \langle \alpha, \beta \rangle \end{array} \right]$$

However, no agreement features in (35b) above have been specified for the gapped category itself. Note that the derived rule schema insures that both categories that are gapped, i.e. NP in the rule in (35b) above will necessarily have the same feature. Before explaining how this is to be resolved, I will develop one other point. Linking rules, which are not derived via the derived rule schema also insure that the features on the gaps are identical, e.g. as in the S-Topicalization rule in (36).

36. a. 
$$\left[ \begin{array}{cc} S & S/\alpha \\ \gamma & \gamma \end{array} \right] \quad \alpha \in \{ \overline{VP}, NP, PP \}$$

By virtue of the fact that the rules (36) links up to are rules derived via the derived rule schema, they will, together with the linking rules, insure that the same feature is passed down the tree. A simplified tree diagram will show how this is so.



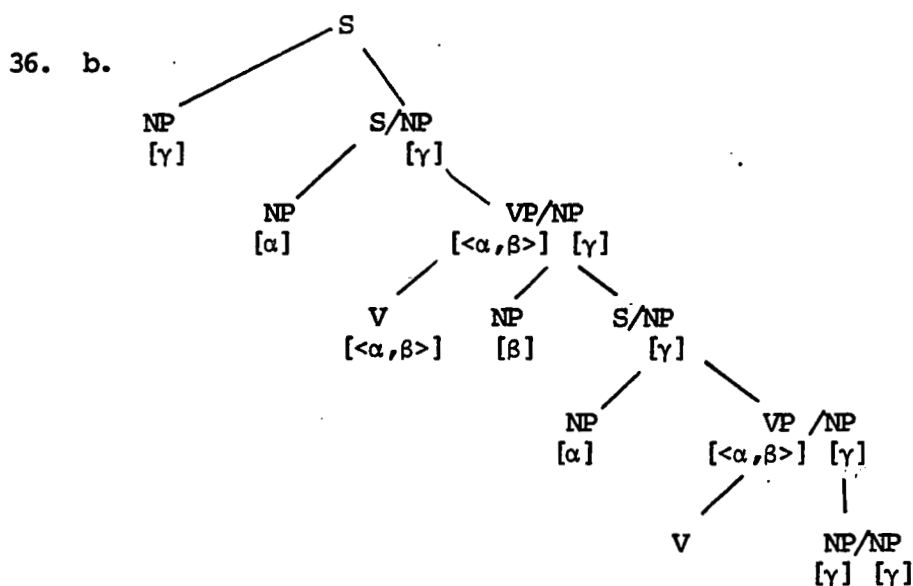

The analysis thus far makes two predictions. First, it predicts that an embedding verb will not agree with an NP gap which is "passed up through it". That this prediction is correct is exemplified by the example in (37) below in which an embedding verb is in agreement with its own object not with the topicalized object.

37. báásikely-úlé Araárima a-no---cúwél-a wiirá. mwaánólé  
 bicycle-dem Araarima sa-t/a-know -t/a that child-dem
- ∅-ho -{<sup>n̄</sup>}- rwéhél-á  
 (\*∅)  
 sa-t/a-oo-repair-t/a  
 'the/that bicycle, Araarima knows that the child has repaired'

The second prediction made thus far is that the embedded verb also does not agree with the gapped NP (as in the example in (37) above). This prediction is false. The bottom clause in which the gap shows up must agree with the noun that has been "extracted". The bottom clauses are distinguished from any other clause formally, so that it is possible to stipulate agreement. The following metarule will insure that the bottom clause has the correct agreement for object gaps.

$$38. \begin{array}{c} [_{VP/NP} X \quad NP/NP \quad Y] \\ [Y] \quad [Y] \end{array} \Rightarrow \begin{array}{c} [_{VP/NP} X \quad NP/NP \quad Y] \\ [\beta] \quad [\beta] \end{array}$$

The metarule insures the correct agreement for object gaps not only for S-Topicalization but for VP-Topicalization.

An additional rule is needed for subject gaps. This is given in (39). It will account for the agreement of a subject gap in the clause from which it is missing. The fact that this agreement needs to be stipulated twice suggests that there might be subject-object asymmetries. There is at least one in Makua, the "funny agreement" noted in the previous section on agreement and metarules. It is unclear to me whether this supports the distinction in the two rules above without having fully formalized that part of the analysis. Nevertheless, the rule in (39) will account for subject gap agreement facts in (39b) below.

$$39. \text{ a. } \begin{array}{c} [_{S/NP} \quad NP/NP \quad VP \quad X] \\ [Y] \end{array} \Rightarrow \begin{array}{c} [_{S/NP} \quad NP/NP \quad VP \quad X] \\ [\alpha] \quad [\alpha] \quad [\alpha] \end{array}$$

- b. mwaánólé Araárima {a-neeriha } wiirá ø-ho-n'-rwéhél-á  
 child/dem Araarima {\*a-no-mweeriha} that sa-t/a-oa-repair-t/a  
 báásikeli  
 bicycle  
 'that child Araarima thinks that has repaired a bicycle'

This analysis also interacts with another rule in the grammar to make another, more subtle prediction. Recall, the complement structures captured by the rule  $[_{VP} \quad V \quad Y \quad \bar{S}/Y]$ . In this case we would expect that there  $[\langle \alpha, \beta \rangle] \quad [\beta]$  would be two patterns, i.e. one in which the matrix verb has agreement, corresponding to the rule just mentioned and another, without agreement on the matrix verb, and which corresponds to the rule  $[_{VP} \quad V \quad \bar{S}]$ , together with  $[\langle \alpha, \beta \rangle]$

Topicalization. In (40a) which corresponds to the tree in (41a), an NP has been topicalized directly out of the embedded sentence. There is no object agreement on the matrix verb. In (40b) corresponding to (41b) the topicalized NP has as its gap postverbal position following the matrix verb and agreement is triggered.

40. a. báásikely-úlé Araárima a-no-cúwél-a wiirá mwaán-ólé  
 bicycle-dem Araarima sa-t-know-t that child-dem  
 Ø-ho-ń-rwéhél-á  
 sa-t-oa-repair-t  
 'that bicycle, Araarima knows that the/that child repairs (it)'
- b. báásikely-úlé Araárima a-no-ń-cúwél-a wiirá mwaán-ólé  
 Ø-ho-ń-rwéhél-á  
 'that bicycle Araarima knows of it that the/that child repaired (it)'

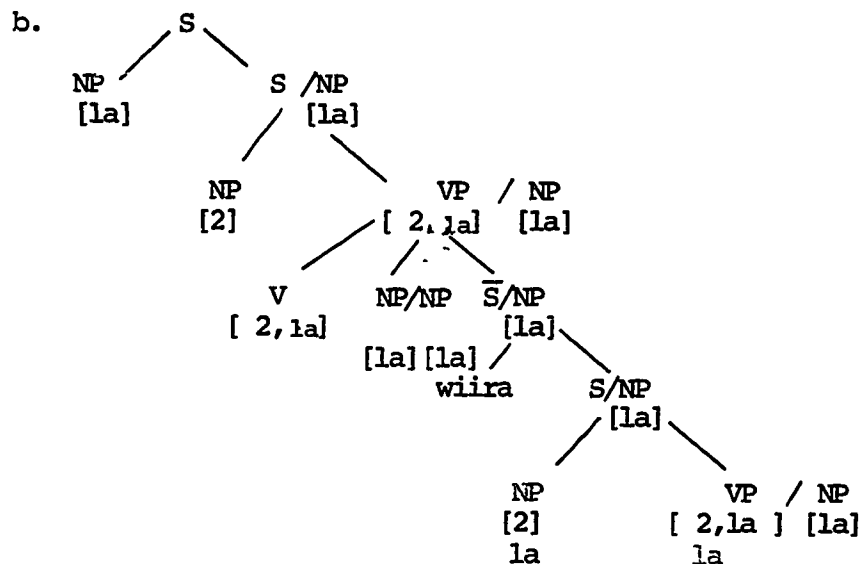
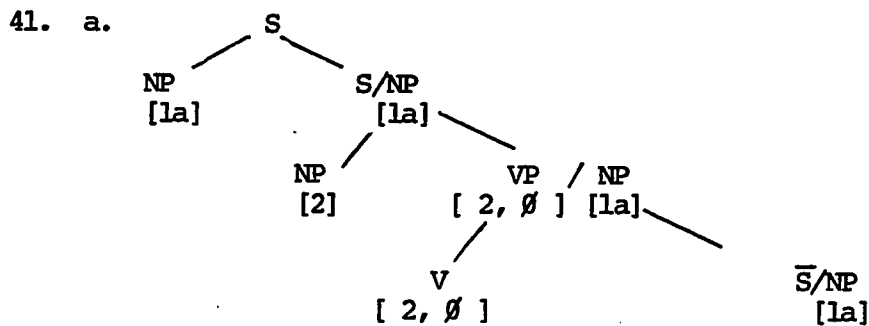

This analysis also makes yet another interesting prediction. It claims that any NP "gap" triggers agreement. This means that even direct objects of bitransitive verbs which do not trigger agreement according to the basic agreement schema should get agreement in the structures involving linking rules. In the clear cases this prediction is borne out. Take a case in which the applied object is of a noun class which does not have an object agreement prefix but the direct object is. In (42) below, no object prefix shows up if the Class 3 noun (nténgá 'messenger') is interpreted as the applied object. If agreement with the Class 1a noun (báásikeli 'bicycle') is put in, then the sentence must be taken to mean that the noun is the applied object as in (42a). However, when the direct object is topicalized by either the VP-Topicalization rule as in (42b) or by the S-Topicalization rule as in (42c) (these being the only way to get these word orders in this analysis) we find that the direct object indeed triggers agreement.

42. a. míi ki-ho-n̄-th<sup>h'</sup>um-él-á nténgá báásikely-úlé  
 I sa-t/a-oa-buy-app-t/a messenger bicycle-dem  
 'I have bought a messenger for the/that bicycle' - unlikely situation
- b. VP-Topicalization  
 míi báásikely-úlé ki-ho  $\left. \begin{matrix} -(\acute{n})- \\ (*\emptyset) \end{matrix} \right\}$  th<sup>h'</sup>um-él-á nténgá  
 I bicycle sa-t/a-oa-buy-app-t/a messenger  
 'I have bought the bicycle, (as expected), for a messenger'
- c. S-Topicalization  
 báásikely-úlé ki-ho  $\left. \begin{matrix} -(\acute{n})- \\ (*\emptyset) \end{matrix} \right\}$  th<sup>h'</sup>um-él-á nténgá  
 bicycle-dem I sa-t/a-oa-buy-app-t/a messenger  
 'the/that bicycle I have bought for a messenger'

Thus, for these examples, the prediction that any gapped NP regardless of its grammatical relation will trigger verb agreement is borne out. In addition, there is the same supporting evidence from another word order which has two possible analyses in the word order analysis, one which involves a linking

rule and one which does not. As predicted, this double analysis should predict that there would be two possibilities, one with agreement and one without. This is in fact the case, as illustrated by the example in (43) below. The order is S DO AO V. It could either be analyzed by the VP-Topicalization rule together with the Variable Order VP rule (in which case we expect agreement) or by the Variable VP order rule together with the VP Object Final rule (in which case no agreement is expected). The optionality in this case supports the claim that gapped NPs trigger obligatory agreement.

43. mii baasikely-ule ntengole Ki-ho-(n)-th<sup>h</sup>um-el-a  
 I bicycle-dem mess/dem sa-t/a-(oa)-buy-app-t/a  
 'I (as expected) bought the bicycle for the messenger'

Accordingly, the rule [<sub>S</sub> S/NP NP] ought to induce agreement as well. That is, in a sentence with this order: V AO S DO where the DO can only get in this position by means of the NP to the Right rule, one expects agreement with the DO. In this case, the facts are hard to interpret. First, there doesn't seem to be any reading V AO S DO at all, as in example (43). Instead, Agreement is taken to be indicative of the AO. Leaving out agreement doesn't help at all: the sentence, the consultant claims, wouldn't be used that way, but if he had to interpret it it would have the reading V DO S AO, where nothing triggers agreement. Here is a plausible scenario for the fact that the above sentence has only one reading. First, it could be that this sole interpretation reflects a parsing strategy. What could be going on is that the verb is followed by an NP that is not in agreement with the verb (in fact cannot be) but the verb has agreement indicating in at least one analysis that that NP must be the DO since DO's don't trigger agreement. Then, the final

NP shows up and it is interpreted as the AO. Now, is there any reason to think that a parsing strategy might be involved in this instance? If there is anything to the discourse function as I understand it, then the answer is yes. First, postverbal position is where new information (new in the sense that the hearer is not expected to know the role of the participants) so that even context will not help in deciphering the role of NPs following the verb. Thus, it is plausible at least that in this case there is something going on besides pure syntax. The fact that some interpretation is now allowed in postverbal position but in preverbal position there is context to help out, points to a difference between these examples and the ones discussed previously (42), where all the NPs preceded the verb.

The analysis also predicts that when both the AO and the DO, for example, are of different noun classes but both noun classes have object agreement, then the Topicalized DO should trigger agreement, at least optionally, since the revised derived rule schema and linking rules claim that this is so. Well, such optionality does not exist in my sample. What happens is that in an example like that in (44), the Topicalized NP is always taken to be the AO.

44. mpírólé míí ki-ho-ń-th<sup>h</sup>úm-a nigurudúúmu  
 (Cl.1a)-tire/dem I sa-ĕ/a-oa-buy-t/a rim(Cl.5)  
 'For the tire, I bought a rim' not 'The tire, I bought for a rim'

Forcing the second reading is not possible even with the contexts I have been able to come up with. Invoking a parsing strategy in this case is a little harder to motivate since the examples involve pre-verbal NPs. However, I am not sure what the status of topicalized NPs with respect to discourse function is. It is worth pointing out that the lack of a second reading could have explanations other than strictly syntactic ones and the fact that these sentences are syntactically complicated (more so than the ones created by the

basic rules) suggests that it is difficult to draw any firm conclusions.

Still, in some cases the direct object agreement does show up as predicted and these puzzling facts are accounted for.

## 5. Conclusions and Implications

In this section I would like to discuss the support that this analysis of verb agreement gives for the rules in Chapter IV, the implications for agreement in general, and the implications with respect to syntactic basic order as defined in this framework.

First of all, the agreement facts support the distinction between orders defined by linking rules and derived rules on the one hand and basic rules and metarules on the other. This is because of the necessity for formulating the agreement features separately for the bottom clauses which predicted some otherwise puzzling facts about the agreement of direct objects in double object constructions. In addition, some meager support from "funny agreement" for the absence of the verb phrase in just one order (...VS...) emerged.

The particular kind of analysis given here, one which involved syntactic features directly in the rules themselves, necessitated the spelling out of agreement for various kinds of rules. To a certain extent, this option seemed of value since it was possible to capture some of the idiosyncratic facts about agreement in Makua. It should be pointed out that this analysis is perhaps not the only way to do agreement in this framework although I have not come up with anything that will allow for agreement to not correlate with grammatical relations in the cases where it does not in Makua.

With respect to the issue of basic order, the most that can be said is that there seems to be some value in specifying agreement for some order only once since it can interact with the metarules and derived rule schema

in a straightforward way for a large subset of the cases. If the orders had been all specified by basic rules, then agreement would have been less general, since agreement would have to have been stated for each order separately. But this is a matter of degree, and it is hard to tell whether it is of great enough degree to be significant. As far as I can tell, nothing in the verb agreement analysis chooses between picking as basic VSO and deriving SVO by metarule since the end result would be the same. For that matter, it doesn't choose between VOS and VSO since they have to be stated separately in any case. Thus, this part of the grammar does nothing more for picking out a single basic order than the analysis of word order itself.



## NOTES

<sup>1</sup>The derived verb phrases again suggest that placing the agreement features on the S node would have to require that somehow bitransitive structures be differentiated at that level so that applied objects get agreement when they have to and the optionality of the instrumental constructions is accounted for. While the present analysis which places the agreement at the VP level seems a bit disunified it is the case in Makua that agreement is not altogether unified. And, as I point out, other Bantu languages have this variability as well.

<sup>2</sup>In English, for example, where agreement does not differ for transitive and intransitive verb phrases, an analysis which places agreement features at the S-level may very well provide a more general account. In addition, I have not explored the ramifications of looking for universals with respect to the metarules or the linking rules although this would be a reasonable place to look. Rather, I have done what was necessary for Makua and it remains to be seen how other languages turn out.

## CHAPTER VI

## 1. Introduction

In this chapter I develop an analysis of the syntax of Makua relative clauses.<sup>1</sup> This analysis provides support for the general analysis proposed thus far in two ways. First, it supports how agreement patterns in relative clauses make use of the separate agreement statements in that analysis. In particular, the bottom clause phenomena facts are correctly predicted for the relativization. Secondly, additional evidence is also given for the presence of a syntactic verb phrase in some orders (e.g. SVO) but not in others (e.g. VSO and VOS).

In addition to the above issues, it is hoped that the discussion will provide a more detailed look at part of the syntax of Makua. Because of certain morphological behavior, in particular, the distribution of demonstrative suffixes (typical of NPs but not sentences), it is necessary to treat the structure of NPs as well. Such morphology is often taken to be indicative of nominalized relative clauses, i.e. sentences related to NPs. Such an analysis for relative clauses in Makua is argued against for two reasons. One is that treating a relative clause as an NP makes the wrong predictions with respect to the distribution of the demonstratives. Secondly, it is shown how the nominal morphology that appears at the end of Makua relative clauses can be predicted if the [<sub>NP</sub> Nom S/NP] rule is adopted for the relative clauses together with the NP rules needed independently in the language.

The structure of this chapter is as follows. In Section 1, the facts to be accounted for are laid out. In Section 2, I introduce a partial analysis of NPs in Makua and show how their structure together with the structure of the relative clauses accounts for the distribution of demonstratives at the end of relative clauses. In Section 3, the analysis of verb agreement in relative clauses is taken up. The fourth section contains a discussion of a special agreement suffix which shows up on relative clause verbs. The final section summarizes the findings and states the implications for both the analysis and the framework under investigation.

## 2. Relative clause facts

Since the facts to be accounted for are somewhat detailed, it will be helpful to lay out certain of these before the analysis is introduced. Relevant general observations include the following. First, there are no morphemes between the head noun and a relative clause. That is, there is no word analyzeable as a WH-word or complementizer.<sup>2</sup> In the examples in (1) below, a subject is relativized. Note that the head and its relative clause may precede or follow the verb. The head noun comes first immediately followed by the relative clause verb, fully tensed although its t/a morphemes can be drawn only from the Set A as outlined in Chapter II, with all verb agreement intact.

1. a. *náfúnzi aaríh-íle ikitááb-(úlé) u-ho-rwáá*  
       student sa/t/a/lose-t/a book -(dem) sa-t/a-go-t/a  
       'the student who lost a book has (already) left'
- b. *u-ho-wáá náfúnzi aaríh-íle ikitááb-(úlé)*  
       sa-t/a-go-t/a student sa/t/a/lose-t/a book-(dem)  
       'the/that student who lost a book has (already) left'

Secondly, the head noun always precedes the relative clause. In addition, no

categories other than noun modifiers (i.e. adjectives and possessives) may intervene between the head and its relative clause. Thus in (2a) below, the head noun is modified by an adjective (the only order for a noun and an adjective in any case) and the sentence is grammatical. The intervention of an adverb, while not ungrammatical altogether, signals a different construction, a noun followed by a parenthetical relative clause with a pronominal head. This difference is reflected in the translation of (2b).

2. a. Hín-Sepété áhó-nmwyá-a báásikeli nkíná nno-t<sup>h</sup>úná  
 Sepete sa/t/a-oo/take-t/a bicycle other sa/t/a-want  
 uth<sup>h</sup>úná nnáfúnzy-úlé  
 to buy student-dem  
 'Sepete took the other bicycle that a student wants to buy'
- b. Hín-Sepété áhó-nmwyá-a báásikeli nkín-úlé ncáná  
 Sepete sa/t/a-oo/take-t/a bicycle other-dem yesterday  
 úlé-nno-t<sup>h</sup>úná uth<sup>h</sup>úná nnáfúnzi  
 dem sa/t/a-want to buy student  
 'Sepete took the other bicycle yesterday, that one which a student wants to buy'

In fact, the two examples in (2) behave quite differently with respect to the distribution of demonstratives, justifying a separate analysis. Since the behavior of demonstratives in relative clauses is parallel to that of NPs, I will postpone a full discussion of this evidence until the analysis itself is taken up. Briefly, however, for relative clauses like those in (2a), a demonstrative suffix in agreement with the head noun can optionally be found attached to the last word of the relative clause regardless of the category of that item (as in (2a) above). If there is such a demonstrative suffix, then an optional demonstrative prefix can be attached to the head noun as in (3). Like the suffix, the prefix agrees with the head noun of the relative clause.

3. Hín-Sepété áhó-nmwyá-a (úlé)-báásikeli nkíná nno-t.<sup>h</sup>úná  
 Sepete sa/t/a-oa/lose-t/a (dem)-bicycle other sa/t/a-want  
 uth<sup>h</sup>úná nnáfúnzy-úlé  
 to buy student-dem  
 'Sepete took that bicycle which a student wants to buy'

The demonstrative prefixes and suffixes are identical down to their idiosyncratic phonological properties with respect to vowel coalescence. Any other pattern of demonstratives (i.e. both prefix and suffix on the head noun, for example) is either ungrammatical or indicative of the kind of structure of (2b), a parenthetical relative clause with a pronominal head. These facts are discussed in more detail in Section 3.

Word order in relative clauses is obviously a relevant issue, but since some of the facts were discussed in Section 4.2 of Chapter III, I will not repeat the examples here. Basically, there is a tendency for the verb to come first in a relative clause. Thus, the preferred order for any relative clause is that in which the NPs, regardless of their grammatical relation, follow the verb. It is not clear that this tendency should be made into a syntactic constraint since, as I point out in Chapter III, it could be that the presence of the verb first facilitates understanding, or that there is some functional correlate to the orders which, in conjunction with the function of relative clauses, turns out to favor a verb first order. The analysis proposed here puts no constraints on order in relative clauses.

Another relevant fact is that only NPs can be relativized. And, parallel to the topicalization cases, no NP can be relativized out of a prepositional phrase. Thus, the following sort of interaction is prohibited.

4. \*mwaálo aa-tupúñle Hín-Sepété inámá ni ...  
 knife sa/t/a-cut/t/a Sepete meat with  
 'the knife with which Sepete cut meat...'

The fact that there are no PP/NP categories in Makua would be treated at the point in the grammar in which the slashed categories are first defined.

However, since prepositional phrases can be topicalized, relativization of the PPs will have to be blocked. This will be achieved by the linking rule for relative clauses which will specify that only NPs can be relativized (i.e. [ Nom S/ ]  $\in$  {NP}). Thus, neither of these constraints will actually cost anything in the grammar. Note however, that the PPs behave as islands for all "extractions" and this is formally represented differently from the fact that PPs cannot be relativized themselves.

The facts just discussed hold true of relative clauses regardless of whether a subject or an object NP is relativized. However, there are two facts which distinguish subject relativization from non-subject relativization when an NP is relativized out of a simple sentence. The facts discussed immediately below do not hold for relativization out of embedded sentences. They only hold for the top-most clause along the "extraction path." These latter facts are taken up in the course of the analysis. One difference is the behavior of verb agreement on relative clause verbs. The second is the appearance of a special agreement suffix on relative clause verbs.

The agreement facts are these. When non-subject NPs are relativized out of a simple sentence, subject agreement on the relative clause verb may be either with the subject of the relative clause or with the head noun. This option is illustrated by the example in (5). The morphology of the head agreement is identical to what it would be if it were the subject. Given a choice, the consultant prefers head agreement rather than the subject agreement regardless of the order of the words in the relative clause, but subject agreement is not at all ungrammatical.

5. riváká  $\begin{cases} \text{naa} \\ \text{aa} \end{cases}$  -han-ílé Hín-Sepéte-(nné)  
 spear sa/t/a- forge-t/a Sepete - (dem)  
 'the spear that Sepete forged...'

In addition, even when the subject does not trigger agreement, and the relativized object does, that relativized object still triggers object agreement. Note in (6) below that the verb agreement is obligatory just as it was for topicalized NPs in the verb agreement analysis in the preceding chapter.

6. báásikeli aa-  $\begin{cases} \text{n} \\ * \emptyset \end{cases}$  -th<sup>h</sup>uménle Aráárima nt<sup>h</sup>éng-ólé  
 bicycle sa/t/a -oa-buy/app/t/a Araarima messenger  
 'the bicycle that Araarima bought for a messenger...'

The second difference attributable to non-subject relativization is the appearance of a suffix on the relative clause verb in agreement with the subject of the relative clause. This suffix is optional in one order, i.e. when the subject immediately follows the verb. This is that order in which there is no syntactic verb phrase (as dictated by the Verb Initial metarule). Note that this is the second time that agreement is different for this order; the first was those examples of "funny" agreement in which the direct object triggered subject agreement under certain semantic and pragmatic conditions in Chapter V. This agreement shows up elsewhere as part of the possessive morpheme suffixed to nouns and to infinitives in nominalizations. Its relationship to the other forms is taken up in Section 4 of this chapter. In (7a) below, however, are examples showing the optionality of this suffix in the VS order within the relative clause. The examples in (7b-c) illustrate the obligatoriness of this suffix in other orders.

7. a. nrááko waa-reély-(ááwé) mmiráwo rát-ólé...  
 trap sa/t/a-set/t/a-(ag suff) boy well-dem  
 'the trap that the boy set well...(as opposed to those someone else set badly)

7. b. nrááko mmíráwo waa-reély- $\left\{ \begin{array}{l} \text{ááwé} \\ * \emptyset \end{array} \right\}$  rátólé  
 'the trap that the boy set well... (as opposed to those he didn't set)
- c. nrááko waa-reély- $\left\{ \begin{array}{l} \text{ááwé} \\ * \emptyset \end{array} \right\}$  ratá mmíráw-ólé...  
 'the trap that the boy set well (as opposed to those he set badly)....'

This then is an overview of some central facts of Makua relative clauses. Other facts will emerge in the course of the analysis.

### 3. The distribution of demonstratives in NPs and relative clauses

I take up the discussion of the demonstratives by first showing how demonstratives interact with the categories of the noun phrase. I will argue that the distribution of demonstratives in relative clauses is directly related to the behavior of the NPs. I will assume a three bar NP, using the familiar symbols, NP for  $\bar{\bar{N}}$ , Nom for  $\bar{\bar{N}}$ ,  $\bar{N}$  for  $\bar{N}$ , and N for N.

The demonstrative affixes are made up of an agreement prefix and a stem. (A full table of demonstrative forms can be found in Appendix A.) Makua, like many other Bantu languages, signals a three way deictic distinction; near the speaker, near the listener (but not the speaker) and far from both. The demonstratives will be translated as 'this', 'that', and 'that over there'. Their distribution is as follows. A demonstrative suffix may appear optionally on a noun as in (8a). When there is a suffix, the prefix may also appear as in (8b). When just a prefix appears, (as in (8c)), however, the structure in question is no longer an NP of any sort but a copular construction. There is no overt present tense copula although there are overt forms for the other tenses .

8. a. niváká - (íné)  
 spear - (dem)  
 '(the/that) spear'
- b. (íné)-niváká-íné  
 (dem)-spear -dem  
 'that (the) spear'



8. \*c. *ńné-niváká*  
 dem-spear  
 \*that spear (that one is a spear - ok)

Thus, the correct forms for nouns with demonstratives in NPs can be said to be that in (9).

9. a. (dem) - noun - dem  
 \*b. dem - noun

Now when an adjective modifying the noun appears, the adjective always immediately follows the noun, and the demonstrative suffix shows up not on the noun but on the adjective. Parallel to the examples in (8), one finds in (10a) a demonstrative suffix on the adjective and in (10b) a prefix on the head noun and a suffix on the adjective. In (10c), just a prefix demonstrative again results in a copular construction as (8c) did.

10. a. *niváká ni-kíná-(ńné)*  
 spear ag-other - dem  
 '(the/that) other spear'
- b. *(ńné)-niváká ni-kíná-ńné*  
 (dem)-spear ag-other-dem  
 '(that)/the other spear'
- \*c. *ńné-niváká ni-kíná*  
 dem-spear ag-other  
 \*the/that other spear'  
 ('that one is another spear' - ok)

It is a bit tedious to go through the sixteen logical possibilities for demonstrative marking for the noun and adjective so I will simply summarize the results. Only the patterns in (9) result in an NP. Any other combination is either a copular construction or else ungrammatical. Thus (dem)-N A-dem is the NP pattern to be accounted for. All other possibilities need to be ruled out.

More complicated NPs involve genitives. Again, the word order is fixed. The head noun comes first, followed by the genitive marker consisting of an

agreement prefix (in agreement with the head noun) and the stem -*o*, which is in turn followed by another noun. An example without demonstratives is in (11).

11. *ikitáábu yo mwaana*  
 book gen child  
 'a child's book'

Demonstrative patterns are as in (12). The demonstrative suffix is in agreement with the head noun and is found suffixed not to the head but to the end of the genitive phrase as in (a) and (b). The prefix appears in front of the head noun and the demonstrative suffix must be present as well. This is illustrated by the examples in (12).

12. a. *ikitáábu yo mwáán-(ílé)*  
 book gen  
 '(the/that) child's book'
- b. *(ílé)-kitáábu yo mwáán-ílé*  
 (dem) book gen child-dem  
 '(that)/the child's book'
- \*c. *ílé kitáábu yo mwáána*  
 dem- book gen child  
 \*that/the child's book'  
 ('that one is a child's book' - ok)

The following rules account for the distribution of the demonstratives (agreement details aside).

13. a. [<sub>NP</sub> Nom (Dem)]
- b. [<sub>NP</sub> (Dem)Nom . Dem]
- c. [<sub>Nom</sub> N (Gen)]
- d. [<sub>N</sub> N (A)] [<sub>Nom</sub> N (AP)]
- e. [<sub>Gen</sub> Gen N]

The rule in (13a) insures that demonstrative suffixes are always optional (which they are). The rule in (13b) insures that the demonstrative prefix

shows up only if there are suffixes. (13a and b) together with (13c and d) get demonstratives on noun phrases consisting of a noun and an adjective and of a noun and genitive in just the way we want, i.e. (dem)-N- A-dem, (dem)-N - gen-N-dem. These rules enumerate no other patterns, giving the desired result.

I now turn to the relative clause demonstrative patterns. Recall from the example in (3) that there was an optional pattern in which a demonstrative in agreement with the head noun is suffixed to the last word of the relative clause. Just in case the suffix appears, the prefix also may show up, this time prefixed to the head noun. Suppose we adopt the rule in (14) as that for relative clauses tentatively.

14. [<sub>α</sub> Nom S/α ] where α ∈ {NP}

This rule says that a NP can consist of a Nom followed by a sentence with a hole in it.<sup>3</sup> This will in fact be the rule adopted for RC's in Makua but the rest of the motivation is yet to come. This rule will interact with the NP rules in (13) however, to give just the right results for the demonstratives.<sup>4</sup> That is, relative clauses of the pattern in (1) and (3), (6), (7) above, are predicted to be acceptable but any other patterns, i.e. dem N-dem RC, N-dem RC, dem-N RC, N-dem RC-dem, etc., are ruled out.

Now the first two of these patterns predicted to be ungrammatical are not, strictly speaking, ungrammatical. They are, however, relative clauses of the parenthetical sort. How these relative clauses without overt heads should be treated rests, in part, on how sentences without overt subject nouns themselves are to be analyzed.

So far, the analysis of relative clauses accounts for the following facts:

1. The obligatory order of the head noun followed by the relative clause. This holds because there is no rule reordering within the NP.

2. The distribution of the demonstratives. Note that this analysis does not require that relative clauses be syntactically nominalized (i.e. sentences related to NPs) in order to get the correct distribution of the demonstratives. That distribution falls out from the relative clause rule together with the NP rules in (13).

3. Nothing other than an NP may be relativized. This is accounted for by the fact that the linking rule introducing relative clauses specifies only NPs.

In the next section, the analysis just proposed is extended to treat verb agreement in relative clauses.

#### 4. Verb Agreement in Relative Clauses

Verb agreement in *Makua* relative clauses differs from that in main clauses in one important way. As mentioned in the second section of this chapter, where the relative clause facts were laid out, the subject agreement position on the relative clause verb (SA) may be filled with a prefix which agrees either with the subject of the relative clause or with the head noun. The term subject agreement position is retained, although these examples show that not only subjects trigger agreement in this position. Thus, either agreement is acceptable for the relative clauses in (15). In (15a) a direct object has been relativized and the agreement is with the object in object position and either the subject or the object in the subject position. In (15b) is an instance in which an applied object has been relativized. Like the direct object the indirect object governs agreement in the object agreement position and either it or the subject of the relative clause verb

governs agreement in the subject position. As far as I am aware, this pattern holds for relativization of all non-subject NPs regardless of their grammatical relation .

15. a. ák<sup>h</sup>áramú {ki} {haa} lúpat-aáka  
           {a} {ho}  
           lions sa-t/a/oa-hunt- ag suff.  
           'the lions which I have hunted...'
- b. nt<sup>h</sup>ú {aa} {mwāndik-ily-aáyá ásuúlúpáálé ibáruwa  
           {wa} {∅}  
           person sa/t -oa/write-t/a-ag suff old man letter  
           'the person for whom the old man wrote a letter...'

In a subject relative, at least in relativization of a subject out of a simplex sentence, it is impossible to tell whether the subject can trigger agreement as well as the head since it is the case that the agreement is the same. Compare the example in (16) below with the examples in (15) above.

16. ák<sup>h</sup>áramú {a} -no-rúpá ...  
           {a}  
           lions sa-t/a-sleep-dem  
           'lions which are sleeping...'

Relativization out of embedded clauses will be taken up as the analysis progresses.

The first thing to be noted about the agreement analysis for relative clauses is that all of the extensions made for the analysis of agreement in the cases of S-Topicalization and VP-Topicalization will be applicable in relative clauses as well, because the relative clause rule likewise involves both a linking rule and derived rules. The relative clause rule in (17) below will insure that the Nom will have the same noun class feature as  $\alpha$  due to the HFC. The rule also insures that  $\alpha$  and its corresponding gap also have the same feature. Recall that only NPs are relativized in Makua.

17.  $[_{\alpha}$  Nom S/ $\alpha$ ]  $\alpha \in \{NP\}$

This rule together with the bottom clause agreement metarules in the previous chapter will predict that the bottom clause NP gap triggers agreement necessarily. The agreement facts for relativization should, therefore, parallel the agreement facts for topicalization in Makua. That this is true is exemplified by the examples in (18) and (19). First, relativization triggers obligatory verb agreement so that even relativized direct objects in bi-transitive clauses trigger agreement as in the example in (18a).

18. a. báásikeli aa- $\begin{cases} n \\ * \beta \end{cases}$ -th<sup>h</sup>uménle Araárima nt<sup>h</sup>éng-ólé  
 bicycle sa/t/a -oa-buy/app/t/a Araarima messenger  
 'the bicycle that Araarima bought for a messenger!...'

b.

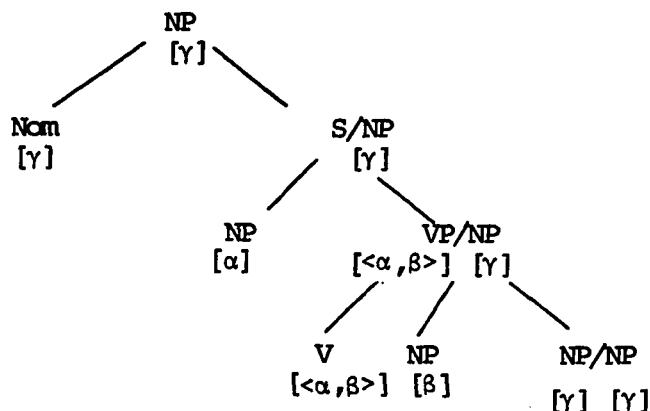

In addition, verb agreement with the relativized NP occurs necessarily in the bottom clause but not in the intermediate clauses. Thus, an embedding verb is not expected to show agreement with the relativized item, unless it happens to be of that class of verbs which subcategorizes for an NP that belongs semantically to a VP complement or an S complement. Then we expect that agreement on an intermediate clause verb would be optional. When

agreement is present, it is due to relativization out of an intermediate clause: non-agreement is attributable to relativization out of the bottom-most clause. This optionality is illustrated by the examples in (19a) and (19b).

19. a. báasikeli ki-n-eerih-ilé wiirá Hín-Sepété a-ho-n-thúm-a  
 bicycle I-*oa*-think-t that Sepete sa-t-*oa*-buy-a  
 'the bicycle which I think (of it) that Sepete has bought...'

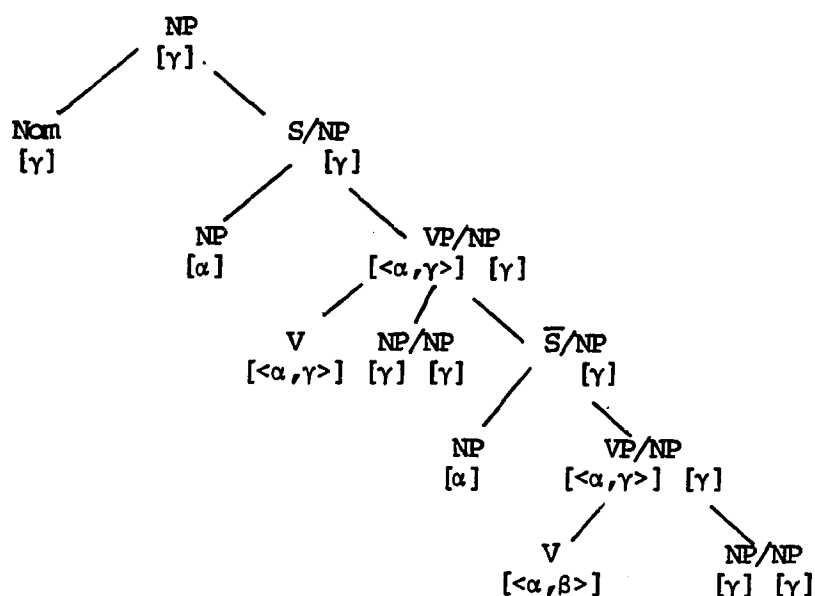

- b. báasikeli ki-neerih-ilé wiirá Hín-Sepété a-ho-n-thúm-a...  
 bicycle I-t/think-t that Sepete sa-t-*oa*-buy-t  
 'the bicycle that I think that Sepete has bought...'

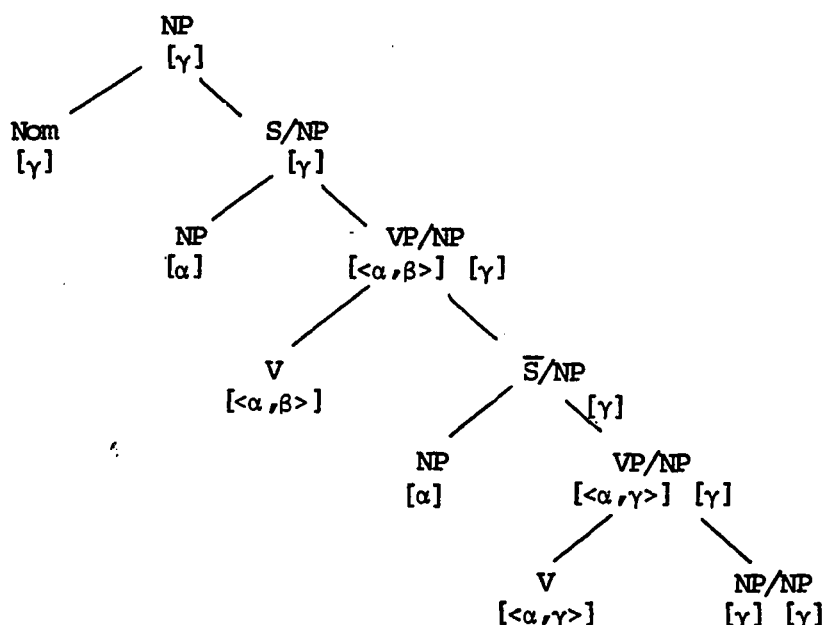

I now turn to the specification of the alternative agreement pattern for relative clauses in Makua. In this pattern, the subject agreement slot on the verb is not filled with the agreement form for the subject of the relative clause. Rather, that slot is filled with agreement with the relativized noun. Non-subject agreement is, strictly speaking, optional, although it appears to be the preferred agreement strategy for the consultant. To begin with, I will add a feature [+R] to the relative clause rule in (20).

20.  $\left[ \begin{array}{l} \text{Nom } S/\alpha \\ \alpha \\ [+R] \end{array} \right]$  where  $\alpha \in \{\text{NP}\}$

This feature is not simply an ad hoc device to capture the agreement facts. It is also used to capture facts about the distribution of the agreement suffix to be discussed in the next subsection. For the moment, however, I will discuss how it interacts with the alternative verb agreement pattern just discussed. To express the optionality of this alternative agreement pattern, the following metarule is adopted.



$$21. \begin{array}{l} [\delta/\theta \ X \ V \ Y] \\ [+R] \\ [<\alpha, \beta>] \end{array} \implies \begin{array}{l} [\delta/\theta \ X \ V \ Y] \\ [<\gamma, \beta>] [\gamma] \end{array}$$

where  $\delta$  is any +V category and  $\theta \in \{NP\}$

This metarule says that any [+R] [+V] category with the agreement pattern [< $\alpha, \beta$ >] can also have the agreement pattern [< $\gamma, \beta$ >] where the subject verb agreement slot is in agreement with the gapped category. The [+V] stipulation is necessary in order to allow alternative agreement in orders in which for those orders in which S is the maximal projection of V (e.g. VSO) and in which VP is the maximal projection of V (e.g. SVO and VOS). Because the HFC will allow this feature only to percolate one clause down, this restricts alternative agreement to the top clause in accordance with Makua facts. The alternative agreement pattern does not show up on the embedded verb. Thus, contrast the grammaticality of (22) below, in which the alternative agreement shows up on the top verb with the ungrammaticality of the alternative agreement pattern in the lower clause.<sup>5</sup>

$$22. \begin{array}{l} \acute{u}l\acute{e} \text{ p}^h\text{i}k\text{i}t\acute{a}a\text{b}u \quad \left\{ \begin{array}{l} \text{eerily-a\acute{a}k\acute{a}} \\ \text{yeerily-a\acute{a}k\acute{a}} \end{array} \right\} \quad \text{wiir\acute{a}} \left\{ \begin{array}{l} \text{a-ho-th\acute{u}m-\acute{a}} \\ \text{* ya-ho-th\acute{u}m-\acute{a}} \end{array} \right\} \\ \text{sa/t/a-say-agg suf that sa-t/a-buy-t/a} \end{array}$$

H\acute{i}n-Sep\acute{e}t\acute{e}

Sepete

'There is a book I say that Sepete bought'

The alternative agreement pattern is not the only top-clause phenomenon in Makua. In Chapter II, I noted that there are two sets of tense and aspect morphemes in Makua, and that one set has restricted syntactic distribution, for example, only one set appears in relative clauses. Importantly, this restriction holds only of the top clause. That is, the tense and aspect morphemes are not restricted in distribution in the embedded clause from

which a noun has been relativized. I have not attempted a formal analysis of these facts in this thesis, but it is important to note that both of these top clause phenomena affect the verb, since it is the use of [+R] together with the HFC which accounts for the agreement facts. It is an interesting empirical question whether all top clause phenomena affect only the verb in all languages. If so, then something like a [+R] feature and the HFC would be well motivated formally. In the next section, I turn to yet another top clause phenomenon, one which also affects the verb and which capitalizes on the [+R] feature introduced in this section.

#### 5. Verb Agreement Suffix in Relative Clauses

In this section I discuss the distribution of a suffix which appears on relative clause verbs. This section begins with a descriptive account and ends with the proposed analysis.

The special agreement suffix happens to be morphologically identical to the agreement suffix part of a possessive marker which appears suffixed to nouns in constructions like that in (23) below. In (23a) is a possessed noun which may appear with or without an overt possessor NP. The possessive suffix is made up of a class agreement morpheme which agrees in class and or person with the possessed noun (in (23a) with a Class 5 noun) and a person agreement suffix signalling agreement with the possessor (in (23a) with a third person sg. initiated noun, /-aya/). In (23b) is a construction which looks suspiciously like a nominalization.<sup>6</sup> In this type of construction the suffix appears on the infinitive form of the verb. The prefix part is in agreement with the infinitive class (/ -u/) which in this case glides to [w-] by regular glide formation rules in the language and the suffix part of the morpheme signals agreement with the subject of the nominalization.

23. a. niváká-náyá (Hín-Sepété)  
'(Sepete's) his spear'
- b. Hín-Sepété wuúlúma-wáyá milátú urikárika  
Sepete to arbitrate-suff disputes be/unpredictable  
'Sepete's arbitrating of disputes is unreliable'

The person agreement suffix (henceforth the agreement suffix) appearing on the relative clause verbs, on the other hand, is missing the first part; only the last agreement part shows up. Its distribution is as follows. First of all, this suffix shows up on a relative clause verb when a non-subject NP is relativized out of a simplex sentence. It agrees with the subject of the relative clause. Such suffixes are obligatory unless the subject immediately follows the verb. Thus, such a suffix is obligatory in examples like those in (24b) and (24c) but optional in (24a) (where the subject immediately follows the verb).

24. a. nraáko waa-reéiy-(ááwé) mmíráwo rát-óié...  
trap sa/t/a-set/t/a-(ag suff) boy well-dem  
'the trap that the boy set well...(as opposed to those someone else set badly)'
- b. nraáko mmíráwo waa-reéiy- $\left\{ \begin{array}{l} \text{ááwé} \\ * \emptyset \end{array} \right\}$  rátólé  
'the trap that the boy set well...(as opposed to those he didn't set)
- c. nraáko waa-reéiy- $\left\{ \begin{array}{l} \text{ááwé} \\ * \emptyset \end{array} \right\}$  rátá mmíráw-ólé...  
'the trap that the boy set well (as opposed to those he set badly)....'

Note that there is no overt agreement in the suffix with anything other than the subject (unlike the cases in (23b) above). The form in the example here is due to normal phonological processes in the language whereby the final /-e/ of the verb glides to [-y] with concomitant lengthening of the initial /-a/ of the agreement suffix /-aya/.

However, it is not the case that the appearance of this suffix is just tied to the relativization of non-subjects. If any NP, subject or not, is relativized out of an embedded sentence then the same facts hold for the matrix verb but not the embedded verb. Thus in the examples in (25) below, no suffix can show up on the embedded verb. Instead, the suffix shows up on the matrix verb optionally if the subject of the matrix subject is immediately following the verb.

25. a. Ki-ho-móón-a báásikeli eerihíly - $\left\{ \begin{array}{l} \text{ááyá} \\ \emptyset \end{array} \right\}$  Araárima  
 sa-t/a-oa/see-t/a bicycle sa/t/a/think/ta-ag suff Araarima  
 wiirá  $\emptyset$ -ho-ń-thúm(\*aaya) mwaán-ólé  
 sa-t/a-oa-buy\*ag suff child-dem  
 'I saw the bicycle (that) Araarima said that the child has bought'
- b. Ki-ho-móón-a báásikeli Araárima eerihíly- $\left\{ \begin{array}{l} \text{ááyá} \\ * \emptyset \end{array} \right\}$   
 sa-t/a-see-t/a bicycle Araarima sa/t/a/think/ta-\*ag suff  
 wiirá  $\emptyset$ -ho-ń-thúm\*(aaya) mwaán-ólé  
 that sa-t/a-oa-buy-\*ag suff child-dem  
 'I saw the bicycle that Araarima said that the child has bought'

The absence of any class agreement morpheme like those found in (25a) and (25b) above suggests two possible analyses of this suffix. One would claim that the suffix is indeed the whole possessive suffix but there just happens to be no overt morpheme for agreement with a tensed verb. Under this analysis one would expect to find some link between relative clauses and possessed nouns and the apparent nominalizations. A second analysis would treat the agreement suffix as just that, a morpheme suffixed directly to the relative clause verb. There is one difference between the distribution of the suffix in relative clauses and nominalizations, at least, which is that of the optionality. This suffix is never optional in the apparent nominaliza-

tions while it is in the relative clauses. Thus, nothing will be lost by trying an analysis which accounts for the agreement suffix in the relative clauses separately from the other cases at first, looking for generalizations to the other cases later.

By way of review, then, here are the facts to be accounted for. An agreement suffix shows up on a verb when a non-subject has been relativized out of that clause. The agreement suffix is in agreement with the subject of that verb. Just in case there is no syntactic VP in the order of the relative clause, then the presence of this agreement suffix is optional.

The first part of an analysis of the distribution and agreement of the suffix is a metarule which picks out the agreement feature for subject NPs in any order in the sentence for [-R] clauses and relates them to [+R] clauses. It passes that subject agreement feature onto an agreement suffix triggered by the [+R] feature. Even though the agreement feature on the [+V] items can be altered by the alternative agreement metarule in the preceding section, this will not affect the agreement of the ag. suffix because the metarule introducing alternative agreement will not affect any other features than those stipulated by the rule and nothing was said about the ag. suffix.<sup>7</sup>

$$26. \quad [S \quad X \left\{ \begin{array}{c} NP \\ VP \end{array} \right\} Y \left\{ \begin{array}{c} NP \\ VP \end{array} \right\} Z] \Rightarrow [S \quad X \left\{ \begin{array}{c} NP \\ VP \end{array} \right\} Y \left\{ \begin{array}{c} NP \\ VP \end{array} \right\} Z]$$

$$\begin{array}{c} [-R] \\ [+R] \\ [+ag \text{ suff}] \\ [\alpha] \end{array}$$

An additional rule stating what a V with the [+R] [+ag. suff.] consists of is needed in the grammar.

$$27. \quad [V \quad V \quad -ag \text{ suff} ]$$

$$\begin{array}{c} [+R] \\ [+ ag \text{ suff}] \\ [\alpha] \end{array}$$

Because the [+ag. suff.] feature is tied to the [+R] feature, the effects of this interaction of rules will be to insure that only the top-most clause of the relativization path is affected. Thus, the facts in examples like (25) above are accounted for.

Note that the above formulation (by stipulating the presence of VP) does not allow for the presence of the ag. suffix in the clauses that do not contain a syntactic verb phrase (eg. VSX). To allow for the optionality of the suffix in such structures, the following metarule is introduced. Thus rules forming the input will not have this feature [+ag. suffix], but the rules enumerated by the output will, accounting for the optionality in the relevant orders.<sup>8</sup>

$$28. \begin{array}{c} [S/\alpha \\ +R \\ +ag.suff.] \end{array} X V Y \Rightarrow \begin{array}{c} [S/\alpha \\ +R \\ -ag.suff] \end{array} X V Y$$

where  $\alpha \in \{NP\}$

## 5. Conclusion

In this concluding section, I will summarize the findings in this chapter and discuss the implications of this analysis of relative clauses for the general analysis of Makua.

The second section of this chapter was devoted, in part, to a detailed discussion of the Makua noun phrase. It was shown that the relative clause was attributable to the structure of relative clauses, [<sub>NP</sub> Nom S/NP], rather than to some nominalization analysis of relative clauses. It was argued that the structure of the relative clause together with the regular NP rules in the language predicted the distribution of demonstratives in agreement with the head noun on the end of the relative clause.

The analysis of the verb agreement in relative clauses (in the third section) provided support for the general agreement analysis in Chapter V by showing that agreement for relativization and topicalization were exactly parallel. In particular, it was shown that relativization triggers obligatory agreement in the clause containing the gap site, having the consequence that a direct object, which normally does not trigger agreement necessarily triggers object agreement when it is relativized. The use of the HFC in conjunction with a [+R] feature introduced for relative clauses made the correct claims about top-clause phenomena, those phenomena that affect only the top-most clause along the "extraction path". This [+R] feature was also used to account for the distribution of a special agreement suffix in relative clauses. Again, the fact that it was tied to the HFC made the correct predictions with respect to the distribution of the agreement suffix in top-clauses. Finally, it was shown how the lack of a syntactic verb phrase in one order (e.g. VSO) but not in others (SVO or VOS) could be capitalized on in order to account for some otherwise idiosyncratic distributional facts, thus lending support to the structures stipulated by the word order analysis in Chapter IV.

## NOTES

<sup>1</sup>This chapter is a completely revised and expanded version of the analysis in a paper, "The syntax of Makua relative clauses" which I presented at the Eleventh Annual African Linguistics Conference, held at Boston University in April, 1980.

<sup>2</sup>In addition, unlike some other Bantu languages (e.g. Tshiluba), Makua relative clauses have no special tone marking setting them off from verbs in other clause types. The only tone differences I am aware of are two: 1) apparent obligatory phrase final lowering at the end of the relative clause and 2) the lack of focus tone within the relative clause itself.

<sup>3</sup>There is one possibly important way in which this treatment of relative clauses differs from that which Gazdar has developed for English. The reader is referred to Gazdar (to appear a) for details. In broad outline, he treats the structures of relative clauses for subject relativization differently from that of relativization of other NPs. Subject relatives consist of a head NP followed by a tensed VP, while object relatives consist of a head NP followed by a S/NP. The way in which he arrives at this difference is by imposing a Generalized Left Branch Condition which bars any category from being "extracted" off a left branch. Imposing this constraint for Makua will not, of course, result in the blocking of subject gaps because of the different word orders. Thus the rule [<sub>S/NP</sub> V NP/NP NP] would be well formed in spite of the Left Branch Condition. In addition, the facts which fall out of this analysis for English (i.e. the differences in the deletion of Wh-words, for example) do not hold for Makua since there are no Wh-words. For those two reasons, then, subject and object relativization proceed in the same manner in this analysis. (But see the discussion in the fourth section of this chapter where the distinction between subject and object relativization is crucial.)

<sup>4</sup>In addition, nominalization (i.e. turning the S/NP into a giant NP) would also make the wrong predictions about verb morphology since the nominalizations, (both the apparent nominalizations discussed in the chapter and the gerundive nominalizations discussed in the Footnote (7) above have infinitives, while the relative clause verbs are fully tensed (in spite of the fact that their tense and aspect is restricted to a particular set).

<sup>5</sup>If relative clauses in Makua had an R-node, then it would be cumbersome to treat agreement in relative clauses. This is because the relative clause rule would be that in (1a-1b) below.

1. a. [<sub>NP</sub> Nom R]
- b. [<sub>R</sub> S/NP]

To define agreement would require both of the feature specifications as in



(2a-b) below. First, an agreement feature would be required for the R-node. Then that feature would have to be passed to the S-"hole".

2. a.  $\begin{bmatrix} \text{NP} & \text{Nom} & \text{R} \\ [\alpha] & & [\alpha] \end{bmatrix}$   
 b.  $\begin{bmatrix} \text{R} & \text{S/NP} \\ [\alpha] & [\alpha] \end{bmatrix}$

This is necessary in order to avoid a partial tree of the sort in (3) which would eventually result in an ungrammatical sentence.

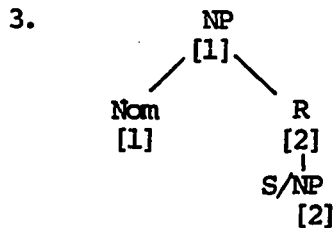

In this way the relationship between the noun class of the head noun and its "hole" is less direct, almost arbitrary.

<sup>6</sup>There are other constructions which are more clearly nominalizations, which could be termed gerundive nominalizations. The following discussion compares the apparent nominalizations and the gerundive nominalizations just for the sake of completeness. No account of these constructions is attempted.

I have consistently used the term "apparent" since these constructions differ from other NPs in important ways. First, the internal order of such structures is not fixed, as illustrated in (1) below.

1. a. uth<sup>h</sup>úma-wáyá ihípá Hín-Sepété vání k<sup>h</sup>anaásíma  
 to buy-suff hoe Sepete now neg/sa  
 tho yaángú  
 'Given Sepete's buying a hoe, now he won't borrow mine again'
- b. uth<sup>h</sup>úma-wáyá Hín-Sepété ihípá...  
 'Given Sepete's buying of a hoe...'
- c. Hín-Sepété uth<sup>h</sup>úma-wáyá ihípá...  
 'Given Sepete's buying of a hoe...'
- d. ihíp-élé uth<sup>h</sup>úma-wáyá Hín-Sepété...  
 'Given Sepete's buying of a hoe...'
- e. ?Hín-Sepété ihip(ele) uth<sup>h</sup>uma-wayá
- f. ihípélé Hín-Sepété uth<sup>h</sup>úma-wáyá...  
 'Given Sepete's buying of the hoe (as expected) ...'

The order within the gerundive nominalizations, like that of the NPs, is fixed. Thus, the order of the gerundive nominalizations must be that in (2) below. No other permutation is grammatical.

2. uth<sup>h</sup>ú má ihípá wa Hin-Sepété waári woóthákiha  
 to buy hoe gen Sepete sa/be inf.  
 'Sepete's buying of a hoe was unintended'

Second, neither gerundive nominalizations (nor NPs) allow gaps. Thus the sentence in (3a) in which a NP has been relativized out of a gerundive is ungrammatical. However, either relativization or topicalization out of the apparent nominalizations is allowed.

3. a. \*ihípá Keerih-ááká waári uth<sup>h</sup>ú má wa Hin-Sepété  
 hoe sa/t/a-think-suff be to buy gen Sepete  
 'the hoe that I thought was of Sepete's buying...'
- b. \*ihípélé uth<sup>h</sup>ú má wa Hin-Sepété waári woóthákiha  
 hoe/dem to buy gen Sepete sa/ag inf  
 'the hoe, Sepete's buying of was unintended'
- c. Hín-Sepété keerih-ááká uth<sup>h</sup>ú má wáyá ihípá...  
 Sepete sa/t/a/think-ag.suff to buy-ag.suff hoe  
 'Sepete who I think's buying of a hoe...'
- d. Hín-Sepete ki-ho-cúwél-a uth<sup>h</sup>ú má wáyá ihípá  
 Sepete sa-t/a-know-t/a to buy-ag.suff hoe  
 waári woóthákiha  
 sa/be to be unintended  
 'Sepete I know his buying of a hoe was unintended'

Thus, the apparent nominalizations are beginning not to look like nominalizations at all.

In addition, the gerundive nominalizations always trigger infinitive agreement in subject agreement position on the verb, but not the apparent nominalizations. Compare the examples in (4) below. (Note tone change on ag. suffix, however).

4. a. uth<sup>h</sup>ú má wáyá ihípá Hín-Sepété wánó k<sup>h</sup>a-naásima  
 to buy-ag.suff. hoe Sepete now neg s/a-t/a/oa/borrow  
 tho yaángú  
 '(Given) Sepete's buying of a hoe, he won't have to borrow  
 mine (again)'
- b. uth<sup>h</sup>ú má wáyá ihípá Hín-Sepété waacokólénle malóvé  
 to buy-ag.suff hoe Sepete sa/t/a/result/app/t/a/ disputes  
 oncúry-álé  
 the day before  
 'Sepete's buying of a hoe was the result of the disputes of  
 the day before yesterday'

Both constructions appear to be equally productive, that is, either a gerundive or the apparent nominalization can be found for most verbs. The differences lie in their syntax. Treating the apparent nominalizations as nominalizations (i.e. dominated by NP) will then make three wrong predictions; the word order would be fixed (which it is not), they should trigger infinitive agreement (which they do not), and there should be no gaps (but there can be).

<sup>7</sup>If one began with a less general rule, say  $[S/NP \quad NP \quad \alpha \quad V / NP]$   
 $[ \alpha ] \quad [ag \quad suff]$   
 $[ \alpha ]$

for example, then the possibility of word order freedom is lost since this rule does not count as input to either the Verb-Initial rule or the NP-Final rule. Hence no rule  $[S/NP \quad V / NP \quad NP]$  would be predicted.  
 $[+ag \quad suff]$

But these are clearly orders which are needed for relative clauses in Makua.

<sup>8</sup>Because of the non-appearance of certain orders in relative clauses due to the verb first tendency it is impossible to determine exactly if the other order which has no VP, (i.e. the one which captures AO DO V S) has the same property.

## CHAPTER VII

## CONCLUSION

## 1. Introduction

In this last chapter, I would like to pull together the findings from the previous chapters in order to discuss the implications for three issues raised by the analysis of Makua in conjunction with the present framework. The first issue to be discussed is that revolving around general questions regarding the syntax of free word order languages. The second concerns the relationship of the notion syntactic basic word order to the analysis proper, on the one hand, and the framework on the other. Finally, certain formal devices of the framework are evaluated with respect to their explanatory value with respect to Makua.

## 2. Free word order languages

The phenomenon of free word order (or free constituent order) has been of interest in syntactic theory since its inception. The seemingly large difference between the syntax of English, say, whose word order is relatively fixed, in contrast to Walbiri, whose word order is remarkably free, have not been pulled together. The recalcitrance of free word order languages to succumb to analysis within standard paradigms has prompted many to inquire if there are fundamentally different kinds of languages. This question has been phrased by Chomsky (1979) within the context of a discussion concerning just this issue.

"...Are there actually two types of languages, quite different?  
Or is there a super-system, of which the two types are species?  
These are crucial questions, which are far from being clearly  
understood."  
(Chomsky 1979:194)

While the present analysis of Makua does not contribute a clear yes or no answer to this question of whether there are fundamentally different kinds of languages, several comments are in order. First of all, Makua is different from both English and Walbiri in the degree of order freedom permitted. On the one hand, Makua does not have a fixed order with respect to subjects, objects, and verbs as English does (and Walbiri doesn't), but on the other hand, the categories of the noun phrase are fixed, unlike Walbiri (or Latin). In addition, certain complement types ( $\bar{S}$ ,  $\bar{S}/NP$  and  $\bar{VP}/NP$ ) always follow the verb, again, unlike Walbiri. Thus, Makua seems to be about midway between the relatively fixed order of English and the very free order of Walbiri. This relativity is suggestive of a continuum rather than a clear-cut distinction. This suggestion is particularly difficult to evaluate without a specific proposal about the parameters along which languages could differ with respect to degree of word or constituent order freedom. Within the present framework, at least, the differences between English and Makua are not formal ones, rather, they differ (perhaps) only in number of rules rather than in rule types, (and even this is not clear). It was suggested at the end of Chapter IV that the effect of "scrambling" in the present framework could be arrived at if there were additional generalizations over classes of rules and, further, that this provided a plausible diachronic scenario for language change. It remains to be seen whether Latin or Walbiri, for example, would be amenable to analyses within the framework being explored here.

Within those formal approaches which do claim a distinction between fixed and free word order languages, whether this distinction is claimed to be a dichotomy (along the lines of Hale (1979) or a graded continuum (Lapointe (1980)) it is difficult to ascertain where Makua fits. Within Hale's dichotomy, which divides languages into those with a syntax of the  $\bar{X}$  sort and those he

terms  $W^*$  languages, it should be pointed out that insofar as the present framework incorporates  $\bar{X}$  syntax, Makua works out pretty well as an  $\bar{X}$  language. It is less clear that Makua would fall into the  $W^*$  type. This last claim is based on two observations. One (mentioned in Chapter IV) is that the semantics in Hale's system would have to be made sensitive to verb agreement since there is no case marking for the categorial signatures to be sensitive to. This modification would, presumably, not be impossible to overcome. However, the facts about verb agreement for simple sentences (in Chapter V) and relative clauses (in Chapter VI) indicate that this will not always be a reliable way in which to insure that subject NPs are subjects and object NPs are objects, because grammatical relations are not always in a one-to-one correspondence with verb agreement.

Secondly, treating Makua as a  $W^*$  language would miss stating the fact that there are syntactic constraints on order in Makua. Thus, the fact that the framework employed here does rely on  $\bar{X}$  syntax and in no way poses any problems, whereas the description of Makua as a  $W^*$  language does pose major problems, it seems likely that Makua would not be like Walbiri, i.e. not a  $W^*$  language.

Lapointe (1980) does not make a dichotomy but, rather, suggests that some languages might have one or both of his sorts of rules: specified and unspecified category rules. The question for Makua then would be which of the orders (if any) is of the unspecified sort, and which are to be characterized by specified category rules. Following Lapointe strictly would force one to choose a single order as basic, if any orders are to be derived by a specified category rule. Other orders would then (presumably) be derived by unspecified category rules. However, it would be difficult to treat both OV and VO, for example, as possible verb phrases syntactically, because one or the other would

have to be derived by an unspecified category rule and hence, that one would not have a syntactic verb phrase. The evidence from the unbounded dependency facts (i.e. VP-Topicalization) suggests that both VO and OV can have syntactic verb phrases. Choosing to characterize Makua by means of entirely unspecified category rules, on the other hand, would result in a serious loss of syntactic generalizations. It is premature to draw any hard and fast conclusions without exploring these alternatives in great detail. Yet, it is important, I think, to note that the treatment of Makua within the framework employed required no new formal devices.

### 3. Basic syntactic order

Chapter III was devoted to a discussion distinguishing the notion of a syntactic basic order from other uses of the term basic order (e.g. typological, marked vs. unmarked). A definition of basic order within this phrase structure grammar was then provided, that order defined by rules not derived by the slashed category schema, the linking rules, or the output of metarules. In this way the basic order is not stated at the level of the rules themselves but at some meta-level. Furthermore, this distinction is not entirely intuitive, since rules enumerated by non-basic rules have equal weight in the grammar. It was suggested that the only way to find out the merits of the definition were to try out an analysis and see what the results were.

As a starting point, SVO was picked as a basic syntactic order. In the end, there was precious little evidence to support this claim. First, it was shown in the chapter presenting the word order analysis, that there was some generalization that verbs preceded their complements rather than the other way around. However, this evidence does not pick between SVO, VSO or VOS.

Still, the word order analysis and the subsequent verb agreement analysis suggested that some basic order was desirable, since certain generalizations could be captured by means of metarules.

This indeterminacy with respect to the choice of a basic order suggests three explanations. First, it could be that the definition of basic order is irrelevant for phrase structure grammars. Secondly, it could be that a syntactic definition of basic order is irrelevant for natural language. In this case, one would look elsewhere in the grammar for a definition of basic order. Thirdly, it could well be that I just haven't found that part of the grammar which would force a choice.

#### 4. Makua and the framework

Two related issues will be discussed with reference to the analysis and the specifics of the framework.

First, it has been shown (not just in this thesis but in all the work thus far) that given the addition of the derived categories and derived rule schema together with metarules, two kinds of generalizations can be made in a phrase structure grammar often argued not to be possible. Unbounded dependencies can be captured in a general fashion with the derived rule schema. Generalizations about the relatedness of word orders not involving slashed categories were stated by metarules. It was shown how this latter device together with some basic assumptions of  $\bar{X}$  syntax (i.e. generalizations over S and VP) led to a simple and elegant statement of order in Makua. Thus, it is not the case that phrase structure grammars are totally incapable of capturing linguistic generalizations (in spite of the increased proliferation of rules over a traditional TG treatment).

The second point with reference to the formalism is more specific to



Makua. The formal distinctions between the derived rules and metarules with respect to predictions about unbounded dependencies and morphology (as discussed in Section 1 of Chapter IV) proved to be enlightening with respect to the syntax of Makua word order. It was possible to separate out distinct syntactic phenomena, those involving unbounded dependencies and those operating within the clause. These separate processes were further reflected in the analysis of agreement where that distinction was capitalized on, in order to account for agreement of direct objects in double object constructions.

Finally, the use of the HFC made possible an account of certain morphology, alternative agreement patterns in relative clauses and the ag. suffix in these same constructions. In this way the formal distinctions were exploited, suggesting the validity of such devices, or, at least, their analogues.

#### 5. End

Much work remains to be done on Makua. Little is known about anaphoric processes or the interaction of such relevant semantic phenomena as quantifier scope and word order. Even though the semantics has been slighted, the syntactic analysis stands, I hope, as a plausible account of a language with a considerable degree of order freedom, governed by recognizable and familiar syntactic principles.

## APPENDIX A

This appendix contains (1) a chart providing the noun class prefixes in the Imit<sup>h</sup>upi dialect of Makua (which are listed by numbers corresponding to noun class prefixes reconstructed for Proto Bantu (Cole (1971)) along with agreement morphemes for subject, object, adjectives and demonstratives and (2) two lists of tense/aspect morphemes, one for those which require contrastive focus and one for those which do not.

I. Imit<sup>h</sup>upi noun class prefixes and agreement forms. A ? indicates that I do not have the relevant data.

Noun class	prefix	sa	oa	adj. ag.	dem. ag.
1. sg.	mu-	∅	mu-	mu-	-ula-, -ule-, -uyo-
1a. sg.	∅	∅	mu or a-	mu-	-ula-, -ule-, -uyo-
2. pl.	a-	a-	a-	a-	-ala-, -ale-, -ayo-
3. sg.	mu-	mu-	∅	mu-	-ula-, -ule-, -uyo-
4. pl.	mi-	i-	∅	ci-	-ala-, -ale-, -ayo-
5. sg.	ni-	ni-	∅	ni-	-nna-, -nne-, -nno-
6. pl.	ma-	ma-	∅	ma-	-ala-, -ale-, -ayo-
9. sg.	i-	i-	∅	i-	-ila-, -ile-, -iyo-
10. pl.	i-	ci-	∅	ci-	-cii-*, -cile-, -ciyo-
14. sg/pl/nt.	u-	u-	∅	u-	-ula-, -ule-, -uyo-
15. infinitive	u-	u-	∅	?	?
16. locative	u-	u-	∅	u-	?
17. locative	va-	va-	∅	va-	-vala-, -vale-, -vayo-
18. locative	mu-	mu-	∅	mu-	?

\*cii surfaces as -ci in suffix position

Personal pronouns	sa	oa
1st person sg.	ki-	ki-
2nd person sg. (child uninitiated)	u-	u-
2nd person sg. (adult initiated)	mu-	u- ni
3rd person sg. (uninitiated)	∅-	-mu-
3rd person sg. (initiated)	a-	-a-
1st person pl.	ni-	ni-
2nd person pl. (uninitiated)	u-	u-
2nd person pl. (initiated)	mu	u-
3rd person pl. (uninitiated)	∅-	∅-
3rd person pl. (initiated)	a-	a-

II. Any of the combinations of tense aspect morphemes in set A below may be used in sentences with contrastive focus, sentential negation (i.e. with the verbal prefix (k<sup>h</sup>a-) or in relative clauses, cleft-like constructions, and constituent questions (but not in echo questions). Those combinations in set B cannot be used in the above mentioned constructions (although they appear in declarative sentences without contrastive focus, in echo questions and with verbs containing the stem negator hi-). Thus the sets of tense and aspect morphemes in a and b are in complementary distribution with respect to the syntactic constructions they may appear in. Each form is accompanied by a label (although these are tentatively assigned). The lists are, in addition, possibly incomplete.

- A. 1. Present tense: sa-no-oa-VS-a  
 2. Present habitual: sa-no-oa-VS-ak-a  
 3. Present iterative: sa-no-oa-VS-es-a  
 4. Present iterative habitual: sa-no-oa-VS-es-ak-a  
 5. Present perfect perfective: sa-oa-VS-ile  
 6. Past perfective: sa-aa-oa-VS-ile  
 7. Past perfective iterative: sa-aa-oa-VS-es-ile  
 8. Future (non-volitional): sa-no-tun-a - infinitive (-tun- = 'want')
- B. 1. Present continuous: sa-aa-no-VS-a  
 2. Present continuous habitual: sa-aa-no-VS-ak-a  
 3. Present continuous iterative: sa-aa-no-VS-es-a  
 4. Present continuous iterative habitual: sa-aa-no-VS-es-ak-a  
 5. Present perfect: sa-ho-oa-VS-a  
 6. Present perfect habitual: sa-ho-oa-VS-ak-a  
 7. Present perfect iterative: sa-hc-oa-VS-es-a  
 8. Present perfect iterative habitual: sa-ho-oa-VS-es-ak-a  
 9. Past: sa-aho-VS-a  
 10. Past habitual: sa-aho-oa-VS-ak-a  
 11. Past iterative: sa-aho-oa-VS-es-a  
 12. Past iterative habitual: sa-aho-oa-VS-es-ak-a  
 13. Past continuous: sa-aa-hoo-VS-ak-a  
 14. Any subjunctive: final suffix -e  
 15. Any conditional: final suffix -eke  
 16. Future: sa-noo-VS-a  
 17. Future habitual: sa-noo-VS-ak-a

18. Future iterative: sa-noo-~~VS~~-es-a
19. Future iterative habitual: sa-noo-~~es~~-ak-a
20. Going-to-Future: sa-noo-wa aa-~~VS~~-a

## APPENDIX B

## I. Basic Rules:

1.  $\langle 1, [S \begin{array}{cc} NP & VP \\ [\alpha] & [\langle \alpha, \beta \rangle] \end{array}], VP' (NP') \rangle$
2.  $\langle 2, [VP \begin{array}{c} V \\ [\langle \alpha, \beta \rangle] \end{array}], V' \rangle$
3.  $\langle 3, [VP \begin{array}{cc} V & NP \\ [\langle \alpha, \beta \rangle] & [\beta] \end{array}], V' (NP') \rangle$
4.  $\langle 4, [VP \begin{array}{c} V \ NP \ NP \\ [+caus] \end{array}], \dots \rangle$
5.  $\langle 5, [VP \begin{array}{c} V \ NP \ NP \\ [+app] \\ [+ben] \end{array}], \dots \rangle$
6.  $\langle 6, [VP \begin{array}{c} V \ NP \ NP \\ [+app] \\ [+loc] \end{array}], \dots \rangle$
7.  $\langle 7, [VP \begin{array}{c} V \ NP \ NP \\ [+app] \\ [+rec] \end{array}], \dots \rangle$
8.  $\langle 8, [VP \begin{array}{c} V \ NP \ NP \\ [+app] \\ [+inst] \end{array}], \dots \rangle$
9.  $\langle 9, [pp \begin{array}{c} ni-NP \\ [+inst] \end{array}], \dots \rangle$
10.  $\langle 10, [VP \begin{array}{ccc} V & NP & PP \\ [+inst] & [\beta] & [+inst] \\ [\langle \alpha, \beta \rangle] & & \end{array}], \dots \rangle$
11.  $\langle 11, [S \begin{array}{c} (comp) \ S \\ [+comp] \end{array}], \dots \rangle$  where  $comp \in \{wiira, eti, thoko\}$   
( $\bar{S}$  is an abbreviation for  $S$ .)  
[+comp]
12.  $\langle 12, [VP \begin{array}{c} V \ \bar{S} \\ [\langle \alpha, \beta \rangle] \end{array}], \dots \rangle$

13.  $\langle 13, \begin{bmatrix} \text{VP} & \text{V} & \text{NP} & \bar{S} \\ & & & [\beta] \\ & & < \alpha, \beta > & \end{bmatrix} \dots \rangle$
14.  $\langle 14, \begin{bmatrix} \text{VP} & \text{V} & \overline{\text{VP}} \\ & & < \alpha, \beta > \end{bmatrix} \dots \rangle$  ( $\overline{\text{VP}}$  is an abbreviation for  
 $\begin{bmatrix} \text{V} \\ \dots \\ +\text{inf} \end{bmatrix}$ )
15.  $\langle 15, \begin{bmatrix} \text{VP} & \text{V} & \text{NP} & \overline{\text{VP}} \\ & & & [\beta] \\ & & < \alpha, \beta > & \end{bmatrix} \dots \rangle$
16.  $\langle 16, \begin{bmatrix} \text{VP} & \text{V} & \text{NP} & \overline{\text{VP}}/\text{NP} \\ & & & \end{bmatrix} \dots \rangle$  or
- $\langle 16, \begin{bmatrix} \text{VP} & \text{V} & \gamma & \overline{\text{VP}}/\gamma \\ & & & [\beta] \\ & & < \alpha, \beta > & \end{bmatrix} \dots \rangle$  where  $\gamma \in \{\text{NP}\}$
17.  $\langle 17, \begin{bmatrix} \text{VP} & \text{V} & \text{NP} & \bar{S}/\text{NP} \\ & & & \end{bmatrix} \dots \rangle$  or
- $\langle 17, \begin{bmatrix} \text{VP} & \text{V} & \gamma & \bar{S}/\gamma \\ & & & [\beta] \\ & & < \alpha, \beta > & \end{bmatrix} \dots \rangle$  where  $\gamma \in \text{NP}$
18.  $\langle 18, \begin{bmatrix} \text{S} & \text{S} & \text{Adv}_\text{S} \\ & & \end{bmatrix} \dots \rangle$
19. Relative Clause rule:
- $\begin{bmatrix} \text{NP} & \text{Nom} & \text{S}/\text{NP} \\ & & [+R] & [\alpha] \\ & & & \end{bmatrix}$
20. NP rules:
- $\begin{bmatrix} \text{NP} & \text{Nom} & (\text{Dem}) \end{bmatrix}$
  - $\begin{bmatrix} \text{NP} & (\text{Dem}) & \text{Nom} & \text{Dem} \end{bmatrix}$
  - $\begin{bmatrix} \text{Nom} & \text{N} & (\text{Gen}) \end{bmatrix}$
  - $\begin{bmatrix} \text{Nom} & \text{N} & (\text{AP}) \end{bmatrix}$
  - $\begin{bmatrix} \text{Gen} & \text{Gen} & \text{N} \end{bmatrix}$
21. Agreement Suffix:
- $\begin{bmatrix} \text{V} & \text{V} & \text{-ag. suff} \\ & & [+R] \\ & & +\text{ag suff} \\ & & [\alpha] \end{bmatrix}$

## II. Linking Rules

## 1. S-Topicalization:

$$\langle 18, \begin{bmatrix} S & \alpha & S/\alpha \\ & [\gamma] & [\gamma] \end{bmatrix} \dots \rangle \quad \text{where } \alpha \in \{NP, \overline{VP}, PP\}$$

## 2. VP-Topicalization:

$$\langle 19, \begin{bmatrix} VP & \alpha & VP/\alpha \\ & [\gamma] & [\gamma] \end{bmatrix} \dots \rangle \quad \text{where } \alpha \in \{NP, PP, \overline{VP}\}$$

## III. Metarules

## 1. Derived verb phrase rules:

$$\text{a. } \langle n, \begin{bmatrix} VP & V & X \\ [-\text{caus}] \\ [<\alpha, \beta>] \end{bmatrix} \dots \rangle \quad \langle n, \begin{bmatrix} VP & V & NP & X \\ [+caus] & [\gamma] \\ [<\alpha, \beta>] \end{bmatrix} \dots \rangle$$

$$\text{b. } \langle n, \begin{bmatrix} VP & V & X \\ [-\text{app}] \\ [-\text{ben}] \\ [<\alpha, \beta>] \end{bmatrix} \dots \rangle \quad \langle n, \begin{bmatrix} VP & V & NP & X \\ [+app] & [\gamma] \\ [+loc] \\ [<\alpha, \beta>] \end{bmatrix} \dots \rangle$$

$$\text{c. } \langle n, \begin{bmatrix} VP & V & X \\ [-\text{app}] \\ [-\text{rec}] \\ [<\alpha, \beta>] \end{bmatrix} \dots \rangle \quad \langle n, \begin{bmatrix} VP & V & NP & X \\ [+app] & [\gamma] \\ [+loc] \\ [<\alpha, \beta>] \end{bmatrix} \dots \rangle$$

$$\text{d. } \langle n, \begin{bmatrix} VP & V & X \\ [-\text{app}] \\ [-\text{loc}] \\ [<\alpha, \beta>] \end{bmatrix} \dots \rangle \quad \langle n, \begin{bmatrix} VP & V & NP & X \\ [+app] & [\gamma] \\ [+loc] \\ [<\alpha, \beta>] \end{bmatrix} \dots \rangle$$

## 2. VP Adverb Metarule.

$$\langle n, \begin{bmatrix} VP & V & X \\ & & \end{bmatrix} \dots \rangle \quad \langle n, \begin{bmatrix} VP & V & X & Adv_{VP} \\ & & & \end{bmatrix} \dots \rangle$$

## 3. Verb-Initial:

$$\langle n, \begin{bmatrix} VP & V & X \\ [<\alpha, \beta>] \end{bmatrix}, \quad ' > \quad \langle n, \begin{bmatrix} S & V & NP & X \\ [<\alpha, \beta>] & [\alpha] \end{bmatrix}, \quad '(NP') >$$



## 4. NP-Final (S)

$$\langle n, [{}_S \text{ NP X}] \dots \rangle \quad \langle n, [{}_S \text{ X NP}] \dots \rangle$$

## 5. Variable Order VP:

$$\langle n, [{}_{VP} \text{ X V } \alpha \text{ Y}] \dots \rangle \quad \langle n, [{}_{VP} \text{ X } \alpha \text{ V Y}] \rangle$$

where  $\alpha \in \{\text{NP}, \overline{\text{VP}}, \text{PP}, \text{Adv}_{VP}\}$

## 6. Variable Order S:

$$\langle n, [{}_{VP} \text{ X } \alpha \text{ V Y}] \dots \rangle \quad \langle n, [{}_S \text{ X } \alpha \text{ NP V Y}] \dots \rangle$$

$[\beta]$

## 7. NP Final Rule (VP)

$$\langle n, [{}_{VP} \text{ V NP X}] \dots \rangle \quad \langle n, [{}_{VP} \text{ V X NP}] \dots \rangle$$

$$\langle ?, [{}_{VP} \text{ VP/NP NP}] \rangle$$

## 8. Instrumental Agreement Metarule:

$$\langle n, [{}_{VP} \text{ V X PP}] \dots \rangle \quad \langle n, [{}_{VP} \text{ V NP X}] \dots \rangle$$

$[\langle \alpha, \beta \rangle]$        $[\text{+inst}]$        $[\langle \alpha, \{\beta, \gamma\} \rangle]$        $[\gamma]$

$[\text{-app}]$        $[\text{-app}]$

$[\text{+inst}]$        $[\text{+app}]$        $[\text{+inst}]$

## 9. Derived Rule-Object Agreement:

$$[{}_{VP/NP} \text{ X NP / NP Y}] \quad [{}_{VP/NP} \text{ X NP/NP Y}]$$

$[\gamma]$        $[\gamma]$   $[\gamma]$        $[\gamma]$        $[\beta]$   $[\beta]$

## 10. Derived Rule - Subject Agreement:

$$[{}_S \text{ NP / NP VP X}] \quad [{}_S \text{ NP / NP VP X}]$$

$[\gamma]$        $[\gamma]$   $[\gamma]$        $[\alpha]$        $[\alpha]$   $[\alpha]$

## 11. Ag. Suffix Agreement:

$$[{}_S \text{ X } \{ \text{NP} \} \text{ Y } \{ \text{NP} \} \text{ Z}] \quad [{}_S \text{ X } \{ \text{NP} \} \text{ Y } \{ \text{NP} \} \text{ Z}]$$

$[\text{-R}]$        $[\text{+R}]$

$[\alpha]$        $[\alpha]$        $[\alpha]$        $[\alpha]$

$[\alpha]$        $[\alpha]$

## 12. Optional Agreement Pattern (Relative clauses):

$[\delta/\theta$ $[+R]$ $[\langle \alpha, \beta \rangle]$	$X \ V \ Y]$	$[\delta/\theta$ $[\langle \gamma, \beta \rangle]$ $[\gamma]$	$X \ V \ Y]$
---	--------------	---	--------------

## 13. Optional Ag. Suffix Rule:

$[S/\alpha$ $[+R]$ $[+ag.suff.]$	$X \ V \ Y]$	$[S/\alpha$ $[+R]$ $[-ag. suff.]$	$X \ V \ Y]$
--	--------------	---	--------------

where  $\alpha \in \{NP\}$

## VITA

NAME: Susan U. Stucky

## PERSONAL DATA:

Birthplace: Portland, Oregon  
 Birthdate: May 22, 1949  
 Citizenship: U.S.

## EDUCATION:

1980-81, University of Massachusetts, Amherst, MA, Postdoctoral fellowship in the Cognitive Science Program

1976-1980, University of Illinois, Urbana, IL, Ph.D., Linguistics  
 Degree to be conferred, May, 1981  
 Dissertation defended and passed, August, 1980

1974-76, University of Kansas, Lawrence, KS, M.A., Linguistics

1971-72, Institute de formation de cadres pour le developpement,  
 Section: Langues modernes - classes de francais, Brussels, Belgium

1967-71, Bethel College, North Newton, KS, B.A., English

1970, India, one semester independent study, under the auspices of  
 Bethel College

1964-65, 66-67, Newton High School, Newton, KS

1965-66, Woodstock School, Mussoorie, U.P., India

## TEACHING EXPERIENCE

1979 (Fall Semester), ESL, Program, University of Illinois

1978-79, Intensive English Institute, University of Illinois

1974-76, Applied English Center, University of Kansas

1972-74, Ecole Secondaire Unie de Katubue, Kananga, Republic of Zaire,  
 With the Teachers Abroad Program under the Mennonite Central  
 Committee

## FELLOWSHIPS:

1980-81, Postdoctoral Fellowship, Cognitive Science Program, University  
 of Massachusetts

## FELLOWSHIPS (cont.)

1978-80, University of Illinois Graduate Fellowships, Department of Linguistics, University of Illinois

1976-78, NDFL, Title VI Fellowships, African Studies Center, University of Illinois

## GRANTS:

1978-79, Graduate College Dissertation Research Grant, University of Illinois

1977-78, Research Grant, African Studies Center, University of Illinois

## PUBLICATIONS

1980 (to appear) Free word order languages, free constituent order languages, and the gray area in between. Proceedings of the North East Linguistics Society Meetings.

1979. with Kathryn Speed Hodges. On the inadequacy of a grammatical relation referring passive rule in Bantu. Studies in the Linguistic Sciences 9:2.

1979. The interaction of tone and focus in Makua. Journal of African Languages and Linguistics. 1:2, 189-198.

1979. Focus of contrast aspects in Makua: Syntactic and semantic evidence. Proceedings of the Fifth Annual Meeting of the Berkeley Linguistics Society. 362-72.

1978. How a noun class system may be lost: Evidence from Kituba. Studies in the Linguistic Sciences. 8:1, 216-233.

1978. Locative phrases and alternative concord in Tshiluba. Studies in African Linguistics. 9.1, 107-119.

1976. Locatives as objects in Tshiluba. Studies in the Linguistic Sciences. 6:2, 174-202.

## PRESENTATIONS (not including departmental colloquia):

1981. Word order freedom and the status of the verb phrase in Makua. Twelfth Annual African Linguistics Conference, Stanford University.

1980. Free word order languages, free constituent order languages, and the gray area in between. Eleventh Annual Meeting of the North East Linguistic Society (NELS XI), Cornell University.

1980. Word order in Makua: (Part of) a phrase structure grammar analysis. Workshop on Niger-Congo syntax. Harvard University.

## PRESENTATIONS (cont.)

1980. The syntax of relative clauses in Makua. Eleventh Annual African Linguistics Conference, Boston University.
1979. Tone and syntax in Makua: The case of focus. Tenth Annual African Linguistics Conference, University of Illinois.
1979. Focus of contrast aspects in Makua: Syntactic and semantic evidence. The Fifth Annual Meeting of the Berkeley Linguistics Society (BLS 5), University of California, Berkeley.
1978. With Kathryn Speed Hodges. On a non-grammatical relation referring passive rule in Bantu. Summer Meeting of the Linguistic Society of America. University of Illinois.
1978. A Problem in Shona morphology. Ninth African Linguistics Conference, Michigan State University.
1977. Transitivity and the interpretation of locative NP's in Tshiluba. Eighth Annual African Linguistics Conference, UCLA.
1976. Reduction of the noun class system in Kituba (Lingua Franca Kikongo), Seventh Annual African Linguistics Conference, University of Florida.

## ACADEMIC ACTIVITIES:

- Member, Student Advisory Panel, Department of Linguistics, University of Illinois, 1976-77
- Member, Colloquy Committee, Department of Linguistics, University of Kansas, 1975-6.
- Member, Curriculum Committee, Applied English Center, University of Kansas, 1974-76.
- Member, Linguistic Society of America

## REFERENCES

- Alt, M. and M. Rubinfeld. (1967) Advances in Computers, vol. 8, Academic Press, New York.
- Bach, Emmon (1975) Order in Base Structure, in Charles N. Li (ed.) Word Order and Word Order Change, Austin Texas, University of Texas Press.
- Bach, Emmon (1976) An Extension of Classical Transformational Grammar, mimeo, Amherst.
- Burke, Victoria and James Pustejovsky (to appear) NELS XI. Proceedings of the Eleventh Annual Meeting of the North Eastern Linguistic Society, University of Massachusetts, Amherst, Massachusetts.
- Bresnan, Joan W. (to appear) The Mental Representation of Grammatical Relations. Cambridge, Massachusetts, The MIT Press.
- Chao, Wynn and Deirdre Wheeler, eds. (to appear) University of Massachusetts Occasional Papers in Linguistics, Volume XI. Amherst, Massachusetts.
- Cheng, Chin C. and Charles W. Kisseberth (1979) Ikorovere (Makua) Tonology (Part I). Studies in the Linguistic Sciences 9:1, 31-63.
- Cheng, Chin C. and Charles W. Kisseberth (1980) Ikorovere (Makua) Tonology (Part 2). Studies in the Linguistic Sciences 10:1, 15-44.
- Cheng, Chin C. and Charles W. Kisseberth (to appear) Ikorovere (Makua) Tonology (Part 3). Studies in the Linguistic Sciences 11:1.
- Chomsky, Noam (1965) Aspects of the Theory of Syntax, Cambridge, Massachusetts, The MIT Press.
- Chomsky, Noam (1970) Remarks on Nominalization, in R. Jacobs and P. Rosenbaum (eds.) (1976).
- Chomsky, Noam (1979) Language and Responsibility. New York, Pantheon Books.
- Chomsky, Noam (1980) On Binding, Linguistic Inquiry 11:1, 1-46.
- Cleaveland, J. and R. Uzgalis (1975) Grammars for Programming Languages: What Every Programmer Should Know About Grammar, New York, American Elsevier.

- Cole, Desmond T. (1971) 'The History of African Linguistics to 1945' in T. A. Sebeok (ed.) (1971).
- Cole, Peter and Jerrold M. Sadock (1977) Syntax and Semantics 8, Grammatical Relations, New York, Academic Press.
- Dowty, David R. (to appear) Grammatical Relations and Montague Grammar, in Jacobson and Pullum (eds.)
- Engdahl, Elisabet (1980) The Syntax and Semantics of Questions in Swedish, unpublished doctoral thesis, University of Massachusetts, Amherst.
- Emonds, Joseph (1976) A Transformational Approach to English Syntax, New York, Academic Press.
- Fodor, Janet D. (1978) Parsing Strategies and Constraints on Transformations, Linguistic Inquiry 9:3, 427-473.
- Frazier, Lyn (1979) On Comprehending Sentences: Syntactic Parsing Strategies, doctoral dissertation, University of Connecticut, reproduced by the Indiana University Linguistics Club, Bloomington, Indiana.
- Gazdar, Gerald J.M. (to appear a) Unbounded Dependencies and Coordinate Structure, Linguistic Inquiry.
- Gazdar, Gerald J.M. (to appear b) Phrase Structure Grammar, in Jacobson, P. and G. Pullum (eds.)
- Gazdar, Gerald J.M. and Ivan A. Sag (to appear) Passive and Reflexives in Phrase Structure Grammar, in J. Groenendijk, T. Janssen and M. Stokhof (eds.)
- Gazdar, Gerald J.M.; Geoffrey K. Pullum, and Ivan A. Sag (MS) A Phrase Structure Grammar of the English Auxiliary System.
- Givon, Talmy (1975) Focus and the scope of assertion: some Bantu evidence, Studies in African Linguistics 6:2, 185-206.
- Greenberg, Joseph (1972) Some Universals of Grammar with respect to the Order of Meaningful Elements, in Allan R. Keiler (ed.)
- Grinder, J.T. and S.H. Elhin (1973) Guide to Transformational Grammar: History, History, Theory, Practice, New York, Holt, Rinehart and Winston.
- Groenendijk, J. T. Janssen, and M. Stokhof (eds.) (to appear) Formal Methods in the Study of Language, Amsterdam, Mathematical Centre Tracts.
- Hale, Kenneth (1979) On the Position of Walbiri in a Typology of the Base, unpublished ms, MIT, Cambridge, Massachusetts.
- Jackendoff, Ray S. (1977) X-Bar Syntax: A Study in Phrase Structure, Linguistic Inquiry Monograph 2, Cambridge, Massachusetts, The MIT Press.

- Jacobs, R. and R. Rosenbaum (eds.) (1976) Readings in Transformational Grammar, Waltham, Massachusetts, Ginn.
- Jacobson, P. and G.K. Pullum (eds.) (to appear) The Nature of Syntactic Representation, D. Reidel Publishing Company, Dordrecht: Holland/Boston: U.S.A./London: England.
- Joshi, Aravind K. and Leon S. Levy (1980) Phrase Structure Trees Bear More Fruit than You Would Have Thought, Proceedings of the 18th Annual Meeting of the Association for Computational Linguistics and the Parasession on Topics in Interactive Discourse.
- Kaplan, Ronald M. and Joan W. Bresnan (to appear) Lexical-Functional Grammar: A Formal System for Grammatical Representation, in Joan W. Bresnan (ed.)
- Keiler, Allan R. (ed.) (1972) A Reader in Historical and Comparative Linguistics, New York, Holt, Rinehart, and Winston, Inc.
- Kisseberth, Charles W. and Mohammed I. Abasheikh (1977) The Object Relationship in Chi-Mwi:ni, a Bantu Language, in Cole, Peter and Jerrold Sadock (eds.)
- Keach, Camillia N. B. (1980) The Syntax and Interpretation of the Relative Clause in Swahili, unpublished doctoral dissertation, University of Massachusetts, Amherst.
- Li, Charles N. (ed.) (1975) Word Order and Word Order Change, Austin, Texas, University of Texas Press.
- Lapointe, Steven G. (1980) A Theory of Grammatical Agreement, unpublished doctoral dissertation, University of Massachusetts, Amherst, Massachusetts.
- Lapointe, Steven G. (to appear) Free Order Phrase Structure Rules, to appear in University of Massachusetts Occasional Papers in Linguistics, Volume VII, Amherst, Massachusetts.
- Maling, J. and A. Zaenen (to appear) A Base-Generated Account of Scandinavian Extraction Phenomena, in G.K. Pullum and P. Jacobson (eds.)
- McCawley, James D. (1968) Concerning the Base Component of a Transformational Grammar, Foundations of Language 4, 243-269.
- Montague, Richard (1970) Universal Grammar, in R. Thomason (ed.)
- Montague, Richard (1973) The Proper Treatment of Quantification in Ordinary English, in R. Thomason (ed.)
- Peters, Stanley and R. W. Ritchie (1969) Context-sensitive Immediate Constituent Analysis: Context-free Languages Revisited, in ACM Symposium on Theory of Computing, New York, ACM-1-8.



- Peters, Stanley and R. W. Ritchie (1973) On the Generative Power of Transformational Grammars; Information Sciences 6, 49-83.
- Pullum, Geoffrey K. (1977) Word Order Universals and Grammatical Relations, in Peter Cole and Jerrold M. Sadock (eds.)
- Roeper, T. and M.E.A. Siegel (1978) A Lexical Transformation for Verbal Compounds, Compounds; Linguistic Inquiry 9:2, 199-260.
- Ross, John R. (1967) Constraints on Variables in Syntax, unpublished doctoral dissertation, MIT, Cambridge, Massachusetts.
- Sager, N. (1967) Syntactic Analysis of Natural Languages, in M. Alt and M. Rubinoff (eds.).
- Schmerling, Susan F. (1971) 'Presupposition and the Notion of Normal Stress,' in Papers from the Seventh Regional Meeting of the Chicago Linguistics Society.
- Sebeok, T. A. (1971) Current Trends in Linguistics, The Hague, Mouton.
- Slobin, Dan I. (1966) The Acquisition of Russian as a Native Language, in F. Smith and G. Miller (eds.).
- Smith, F. and G. A. Miller (eds.) (1966) The Genesis of Language, Cambridge, Massachusetts, The MIT Press.
- Stucky, Susan U. (1979a) Focus of Contrast Aspects in Makua: Syntactic and Semantic Evidence, Proceedings of the Fifth Annual Meeting of the Berkeley Linguistics Society, 362-372.
- Stucky, Susan U. (1979b) The Interaction of Tone and Focus in Makua, Journal of African Languages and Linguistics 1:2, 189-98.
- Stucky, Susan U. (to appear) Free Word Order Languages, Free Constituent Order Languages and The Gray Area in Between, in V. Burke and J. Pustejovsky (ed.)
- Thomason, Richmond H. (ed.) (1974) Formal Philosophy: Selected Writings of Richard Montague, New York and London, Yale University Press.
- Trithart, Lee (1979) Topicality: An Alternative to the Relational View of Bantu Passive, Studies in African Linguistics 10:1, 1-30.
- Vergnaud, Jean-Roger (1973) Formal Properties of Lexical Derivations, Quarterly Progress Report of the Research Laboratory in Electronics No. 108, 280-87, MIT, Cambridge, Massachusetts.
- Watters, John R. (1979) Focus in Aghem: A Study of its Formal Correlates and Typology, unpublished masters thesis, UCLA, Los Angeles, California.