

## Binocular brightness combinations: Additive and nonadditive aspects\*

Ch. M. M. de WEERT and W. J. M. LEVELT

University of Nijmegen, Erasmusaan 16, Nijmegen, The Netherlands

A conjoint measurement procedure is used for the measurement of binocular brightness as a function of left and right luminance inputs. For nonzero stimulation, the data confirm earlier findings: the system can be described as additive with a scale exponent of 1. If zero stimulation is included, however, no additive solution can be found (due to Fechner's paradox). This fact, combined with various critical remarks in the literature with respect to the existence of a real luminance-averaging system, has led us to propose a model which takes account of Fechner's paradox, and incorporates "realistic" exponents without requiring a multistage processing mechanism where different levels are characterized by different sensory scales. The proposed model makes the weighting coefficients for the two eyes dependent in a continuous way on the strength of stimulation in the two eyes, especially on the amount of contrast of the monocular stimuli. For zero background stimulation, contrast can be expressed in terms of luminance of the stimulus. In this way, the model is reduced to a simple testable form. While it is much simpler than Engel's (1969) model, the experimental results indicate that it might also work for the more general case.

Since Fechner (1861) discovered his binocular brightness paradox, there has been no doubt in the literature about the existence of binocular brightness interaction. But brightness interaction may take any of a large variety of forms. On the one hand, one might consider dichoptic interactions in threshold phenomena. More specifically, one could study effects on absolute or differential thresholds, or on critical flicker fusion frequencies. In general, the existence of such threshold effects has been used as an argument for binocular *dependence*, whereas their absence was taken to mean *independence* of the two monocular channels. On the other hand, binocular brightness interaction has been studied with respect to the contributions of the individual eyes to the joint binocular output.

Traditionally, brightness judgments have been used in nonthreshold studies on binocular summation. This work has been reviewed by Levelt (1965) and by Engel (1967, 1969). A main theme in this work has been the question of whether binocular brightness results from a summation or an averaging of the monocular responses. Fechner's paradox suggests the existence of an averaging mechanism. Averaging models have been proposed by Hering and Sherrington (1906), Schrödinger (1926), Livshitz (1940), Levelt (1965), Hurvich and Jameson (1966), and Engel (1967, 1969). However, some evidence for summation can be found in the literature; this is incorporated in models by DeSilva and Bartley (1930) and Fry and Bartley (1933). An important additional issue is, of course, what it is that is summated or averaged: luminances (Levelt, 1965), discriminative responses (Treisman, 1970), or brightnesses (Sherrington, 1906; Hurvich & Jameson, 1966; Engel,

1967; Teller & Galanter, 1967). The problem of dependence vs independence that was raised with respect to the threshold studies now returns in another garment.

Is the binocular effect of a luminance change in one eye dependent on the stimulation intensity in the other eye? It should be clear that the answer to such a question is, among other things, dependent on the choice of response scales. One might have to conclude that dependence exists if effects are measured in terms of a predetermined sensation scale (e.g., a power scale), whereas dependence vanishes if one can freely use a discriminative response scale. However, it is not the case that independence can always be guaranteed by the appropriate choice of scales.

Under certain conditions, one has to conclude that independence cannot be valid, for whatever choice of sensory response scales. To our knowledge, no one has tried, in the literature on binocular brightness, to show that noninteraction is excluded in principle for the binocular system. A first aim of this study was to develop such a test. For this, we took inspiration from the theory of additive conjoint measurement (Luce & Tukey, 1964; Krantz et al, 1971), where noninteraction is brought under the theoretical notion of additivity. The theory formulates the conditions under which an additive, i.e., noninteractive, solution exists for a set of measurements of the conjoint effect of two independent variables. If an additive solution exists, the theory moreover specifies the conditions on the scales. For such a test of additivity, only ordinal data are required, so that a rather simple type of brightness judgment will suffice on the part of the S.

In this article, we will proceed as follows. We will first describe the experiment which allows us to carry out an additivity test for binocular brightness. We will then discuss the data analysis, which leads to the conclusion

\*This work was supported by The Netherlands Organization for the Advancement of Pure Research (ZWO). Theo Schaap had an important part in the production and analysis of the data.

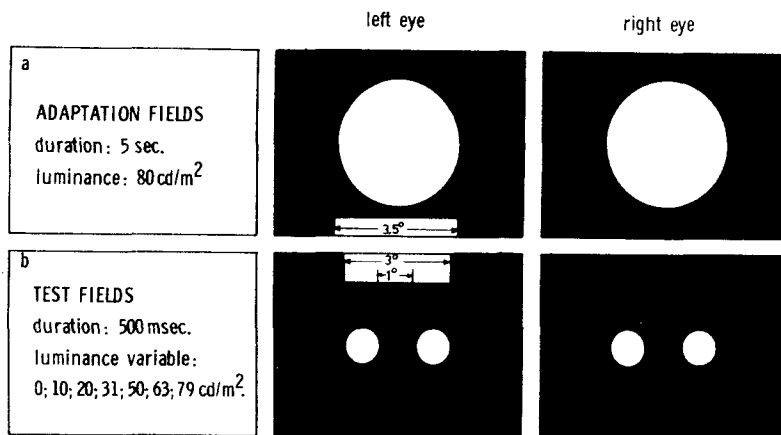

Fig. 1. Stimulus configuration. During the 5-sec adaptation periods, test-field targets are changed.

that the system is nonadditive. This brings us, in the next section, to a discussion of the most important interactive theories of binocular brightness, i.e., where there is some form of dependence between the eyes. There are, especially, models as proposed by Engel and our own version of models as given by Schrödinger and Hurvich and Jameson. Finally, we will compare these models on the basis of the experimental data that also served for the additivity analysis.

### THE EXPERIMENT

As stated in the preceding paragraph, we will be able to test additivity of the binocular brightness system by means of only ordinal data. As we will see, such data will also suffice to test different nonadditive or interactive theories. We decided to base our test on seven luminance values for each eye. This means that we need a rank order over 49 binocular stimulus pairs. This was experimentally realized in the following way.

#### Method

A six-channel Scientific Prototype tachistoscope was used, provided with an automatic slide-change mechanism for one channel in each of the two monocular three-channel parts. One field in each part served as an adaptation field, and at the same time as an aid for fusion. The luminance of these circular, 3.5-deg adaptation fields was 80  $\text{cd/m}^2$ .

The channels equipped with the slide changers were used to present the test stimuli, consisting of two 1-deg circular fields, horizontally aligned and separated by a 1-deg gap (see Fig. 1b). Much care was taken to assure that both left- and right-eye test stimuli exactly coincided in the binocular field, set up by the fusion (adaptation) fields.

Each 1-deg subfield of a test stimulus could have one of seven luminance values, 0, 10, 20, 31, 50, 63, or 79  $\text{cd/m}^2$ , produced by neutral density filters. In all cases, test and adaptation fields had black backgrounds.

Left and right circular slide trays contained all 49 possible combinations of the seven luminance values. The order of the slides was randomized.

**Procedure.** The eyepieces of the two three-channel parts of the tachistoscope were optimally adapted to the S's intereye distance. No artificial pupils were used.

After a 5-sec presentation of the adaptation fields, the first pairs of left- and right-eye test stimuli were presented for 500 msec. In the following 5-sec adaptation period, slides were

changed in both channels and the next pairs of test stimuli were presented. The 500-msec presentation time was chosen as a compromise. It is just long enough to obtain a stable binocular impression, and short enough not to disturb the adaptation level seriously. For each test field presentation, the S's task was to indicate which of the binocularly fused 1-deg fields he judged to be the brighter one. Since, in some cases, the two fields are quite evidently equal in brightness (e.g., where all transmissions are zero and both fields are black), we allowed the S to give "equal" judgments. We didn't allow the Ss to look twice for the same stimulus presentation. On the average, Ss used this option in 2%-3% of the judgments. After each series of 49 presentations, a new series of 49 combinations was started by turning the right-eye rototray one place further. In this way, a total of 49 x 49 stimulus combinations were presented to each S. From the symmetry of the 49 x 49 stimulus matrix, it is clear that each binocular pair is compared twice to all possible binocular pairs, if we may assume that left and right position on the retina are equivalent. We will return to this issue in a later section.

**Subjects.** Two trained, male Ss, S. and W., served in the experiment. Both Ss had normal uncorrected vision. Furthermore, they both had little or no eye dominance, as revealed in earlier binocular experiments. Measures of eye dominance were extracted from metrical equibrightness measurements as described by Levelt (1965), and from extended series of binocular color mixture experiments to be described in another paper.

### RESULTS AND ADDITIVITY ANALYSIS

Let us indicate luminance values in the left-eye stimulus pair by  $(a_l, b_r)$ , luminance values in the right eye by  $(p_l, q_r)$ . Subscripts l and r indicate stimulus field positions (not eyes). After binocular fusion, the pair  $(a_l, p_l)$  forms the left binocular field, whereas  $(b_r, q_r)$  is the right binocular pair of fields. Ss' judgments of the relative brightness of the two binocular fields were registered as +1 (resp. -1) if the right (resp. left) field is the brighter one, as 0 if the option "equal" was used. A 49 x 49 matrix was obtained, with row elements indicating the 7 x 7 binocular stimulus combinations in the right positions in left and right eye, respectively, and column elements indicating the stimulus combinations in the left positions in left and right eye. Counting the number of -1s in one row gives the number of times that a particular left-field combination dominates any of the 49 possible right-field combinations; 0 is taken as

0.5. Counting the number of +1s in one column gives the number of times that a particular right-field combination dominates any possible left-field combinations: 0s are taken as 0.5 again. We can combine the summations over rows and columns, but only if we assume that right-field retinal parts behave in a similar way as left-field retinal parts do. At first sight this seemed to be allowed. Combination of summations over rows and columns gives an ordering of the 49 possible binocular combinations with respect to their joint brightnesses. This ordinal information was used for the analysis of additivity to be described below.

**Conjoint Measurement Theory**

Conjoint measurement theory is concerned with the way in which independent variables, according to some specific composition rule, determine a joint effect. For a general description of these recent developments in psychological measurement theory, we must refer to Krantz, Luce, Suppes, and Tversky (1971). We go into some detail only about the most simple, most elaborated composition rule, the additive composition of functions defined on the independent variables.

Let  $L = a, b, c, \dots$ , be the set of  $m$  left-eye luminance, and let  $R = p, q, r, \dots$ , be the set of  $m$  right-eye luminance values. The cartesian product of  $L$  and  $R$  produces a matrix,  $B$ .  $B$  is the set of possible left- and right-eye luminance combinations. Matrix elements  $b(i,j)$  are numbers related to the joint binocular brightnesses of these combinations, in a monotonic nondecreasing manner.

The matrix,  $B$ , is additive if and only if there are real valued functions,  $f(a)$ ,  $g(p)$ , and  $\beta(a,p)$ , defined on  $L$ ,  $R$ , and  $B$ , respectively, such that: (1)  $\beta(a,p) = f(a) + g(p)$ , and (2)  $\beta(a,p) \geq \beta(b,q)$  if and only if  $b(a,p) \geq b(b,q)$  for all  $a,b \in L$  and all  $p,q \in R$ . Condition 2 leads directly to the requirement of monotonicity of the data matrix. In practical terms, the matrix is monotonic if rows and columns can be permuted in such a way that all rows have elements which are nondecreasing in value from left to right, and all columns are similarly nondecreasing from top to bottom. But a monotonic matrix is not necessarily additive, as can be seen in the simple example given below. For this, still another empirical condition must be fulfilled.

Krantz et al (1971) pointed out that the key property for monotonic two-factor systems is given in the *double cancellation rules* to be derived below:

		p	q	r
Example of a data matrix which is monotonic but not additive:	a	1	3	4
	b	2	5	8
	c	6	7	9

If (i)  $b(a,q) \geq b(b,p)$  and (ii)  $b(b,r) \geq b(c,q)$ , then (iii)  $b(a,r) \geq b(c,p)$ , and similarly for the joint inversion of the three inequalities. For: (i) implies  $\beta(a,q) \geq \beta(b,p)$  or

$f(a) + g(q) \geq f(b) + g(p)$ ; (ii) implies  $\beta(b,r) \geq \beta(c,q)$  or  $f(b) + g(r) \geq f(c) + g(q)$ ; and summing (i) and (ii):  $f(a) + g(q) + f(b) + g(r) \geq f(b) + g(p) + f(c) + g(q)$ . (Double) cancellation of equal terms on both sides leads directly to:  $f(a) + g(r) \geq f(c) + g(p)$  and thus to  $b(a,r) \geq b(c,p)$ . i.e., (iii).

For a  $m \times m$  matrix, there are

$$\binom{m}{3} \times \binom{m}{3}$$

triples to be checked with respect to this cancellation rule. Not all these triples, however, are testable, because Conditions i and ii may have opposite inequality signs. The latter case we will indicate by "no test." Also, the data can violate the double cancellation rule in a very weak manner. This is the case where one of the conditions, (i) or (ii), is an equality, whereas the other is an inequality. If the sign of (iii) is opposite in that case, we have, technically speaking, a rejection. However, with finer grained data, the equality could have gone both ways and in one case we would have had a "no test" situation. Therefore, we will categorize "weak rejections" separately.

A special program, "Cancel," was written, by which all possible triples could be tested with respect to double cancellation. As input, we used the  $7 \times 7$  experimental matrix for which rows and columns were ordered in terms of increasing luminance. Apart from the double-cancellation test, we computed the number of violations of monotonicity for each matrix. One could object to this procedure on the basis that one should use an input matrix with row and column permutations such that maximal monotonicity is obtained. However, it is only natural to expect that if additivity holds, increasing luminance in one eye should have an increasing binocular effect. Moreover, the improvement of monotonicity by such reordering was always very small. If monotonicity and cancellation are established, we may conclude, as shown by Krantz et al (1971), that real valued functions,  $f(a)$ ,  $g(p)$ , and  $\beta(a,p)$ , do exist. Only some additional technical assumptions have to be made, which are of no significant empirical consequence.

How can we find these functions? For this we used the "Unicon" program, developed by Roskam et al (1967, 1968, 1971), which is an extension of nonmetrical multidimensional scaling procedures, such as Kruskal's. We refer to the original publications for details.

Scale values found in this procedure are unique up to linear transformations. That is, if  $f(a)$  and  $g(p)$  are solutions for left and right scales, then  $xf(a) + y$  and  $xg(p) + y'$  are solutions too for all  $x, y$ , and  $y'$ .

**Results of Additivity Analysis**

Table 1 gives the experimental results for the two Ss, S. and W. It is immediately obvious that monotonicity is violated. The number of nonmonotonicities is 22 and 29

**Table 1**  
Dominance Matrices for Binocular Luminance Combinations

		Right eye cd.m <sup>2</sup>															
		0	10	20	31	50	63	79		0	10	20	31	50	63	79	
Left eye cd/m <sup>2</sup>	0	3	6	20	24.5	55.5	74	89	0	2	5	15	27.5	50.5	69	81	
	10	5	4	14	18	34.5	45.5	62	10	4	5	10	20	31	42	51	
	20	13.5	12	21.5	23	38.5	53.5	65.5	20	15	11	19	27	37	51	59	
	31	26.5	17.5	30	28	50.5	59.5	72	31	30.5	20	30	37	51	63	71	
	50	57	33.5	40.5	44.5	61	70.5	84	50	53.5	36	40	55	69	79	87	
	63	73.5	48.5	48.5	57	75.5	82.5	93	63	71	44	53	67	80	83	92	
	79	87	63.5	66.5	76	86	93	94	79	86	63	67	72	88	89	92	
			subject W									subject S					

Note—A matrix element presents the number of times a particular combination of left and right eye luminances is judged to be brighter than any other combination. Maximum value: 98.

**Table 2**  
Reordering of Rows and Columns Leads to an Improvement of Monotonicity. However, the Number of Strong Rejections Strongly Increases

		7x7 matrix W		7x7 matrix S	
Number of violations of monotonicity		29	18	22	14
cancel- lation test	acceptance	502	492	432	526
	weak rejection	3	5	1	9
	strong rejection	20	62	13	66
	no test	700	666	779	624

for S. and W., respectively. Almost all of them involve the first row and the first column. One could think of permuting these vectors; however, in no way can a substantial improvement of monotonicity be made, and if improvement of monotonicity occurs, the number of violations increases, as can be seen in Table 2.

Since the matrices are nonmonotonic, they are nonadditive, which indicates some form of interaction between the monocular responses. The sort of

interaction can be easily deduced: the data are nonmonotonic where the zero stimulus is concerned. This is another expression of Fechner's paradox: the contribution of an eye increases if the other eye is not stimulated. The obvious next question is whether the binocular system is additive in a more limited sense, namely for nonzero stimulation of the eyes. For this, we computed the 6 x 6 data matrices by ignoring all observations which involve a null stimulus. They are given in Table 3.

This time, the matrices turn out to be (close to) perfectly monotonic. To establish additivity, we have yet to test double cancellation. The results of these tests are given in Table 4.

The number of strong rejections is less than 5% for both Ss, whereas weak violations are exceptional. It seems rather safe to conclude that the binocular response is a simple additive function of the monocular stimulations if zero stimulation is excluded. This result is in complete accordance with Levelt's (1965) findings, which for the nonlow luminance range could be described by a simple averaging rule. Is it also the case

**Table 3**  
Limited Set of Binocular Luminance Combinations

		R-eye cd/m <sup>2</sup>						R-eye cd/m <sup>2</sup>							
		10	20	31	50	63	79	10	20	31	50	63	79		
L-eye cd/m <sup>2</sup>	10	1	4	11	18	26	34	10	1	7	8.5	20.5	30.5	44	
	20	3	9	14	21	37	42	20	5	11.5	12	24.5	36.5	46.5	
	31	10	18	23	37	46	51	31	8	17	16	34.5	42.5	52	
	50	21	26	38	50	58	63	50	21	25.5	31	44	51.5	61	
	63	30	35	47	57	60	68	63	33	35.5	42.5	55.5	61.5	68	
	79	45	48	52	63	64	67	79	44.5	48.5	55.5	63	68.5	69	
			subject s								subject w				

Note—Zero luminance is excluded. Matrix elements present the number of times a particular binocular combination is judged to be brighter than any other combination. Maximum value: 72.

that the function is linear with respect to luminances, as in Levelt's equibrightness results? To determine this, we used the Unicon-scaling program. The results for the two Ss are given in Fig. 2.

It is clear from the curves that the interval scale values can indeed be considered as linear functions of luminance. We can conclude that, though the experimental procedure is quite different from Levelt's, our results are in complete agreement with his. This result, however, cannot obliterate the fact that nonadditivities are obtained if the null stimulus is included in the experimental material. This means that any complete model of binocular brightness combination will have an interactive aspect, i.e., the binocular effect of stimulation in one eye will increase for low or zero stimulation of the other eye. Therefore, we will now turn our attention to more complete

Table 4  
Double Cancellation Test for Reduced Sets of Data

	W 6	%of tests	S 6	%of tests
acceptance	156	94	145	96.7
weak rejection	2	1.2	1	0.7
strong rejection	8	4.8	4	2.6
no test	234		250	
number of triples	400		400	

Note—All combinations which involve the null stimulus are omitted.

models, which involve some form of dependence between the two eyes.

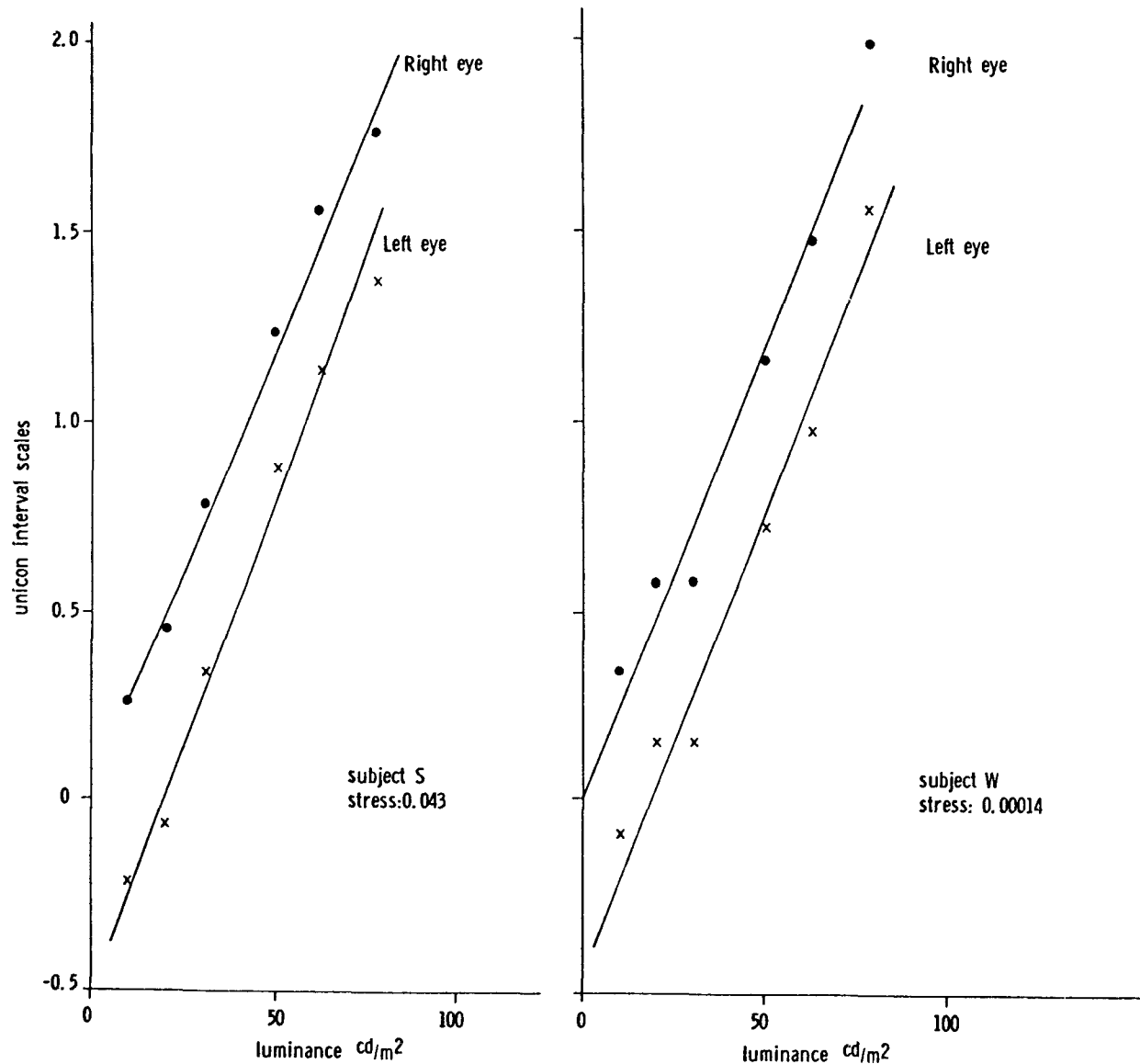

Fig. 2. Scales represent an additive solution for the 6 x 6 reduced data set. Scales are unique up to a linear transformation. See text.

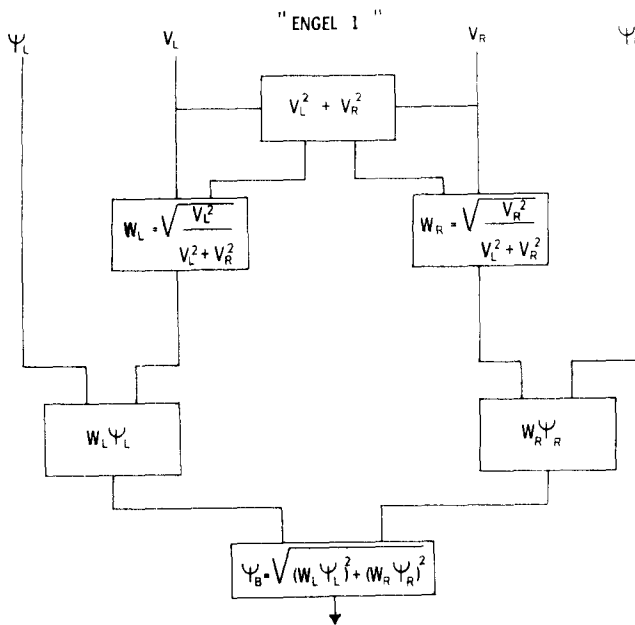

Fig. 3. Our representation of the binocular brightness combination model of Engel (1969).

**INTERACTIVE MODELS**

As we have indicated in the introduction, such models have been around in the literature for a long time. The obvious reason for their creation is the existence of Fechner's paradox, where, in spite of an increase of the total amount of energy reaching the eyes, a decrease of binocular brightness results. This suggests the working of an averaging process in which weighting factors for the two eyes are dependent upon a relation between the monocular inputs.

In this paragraph, we will first review the most important models that have been proposed in the literature. This is, on the one hand, Engel's (1967, 1969) model, which is probably the most complex of all existing models. On the other hand, we have models in the tradition of Schrödinger (1926), Livshitz (1940), and Hurvich and Jameson (1966). With respect to Engel's model, we will argue for also testing two simplified versions thereof, and as far as the Schrödinger tradition is concerned, we will develop one explicit variant of these models, which will be called the "centroid model." After this short review, we will put all four models to test, i.e., Engel's original and its two derived versions, and the centroid model.

**Engel's Vector Summation Model**

Engel's (1969) model, which will be called "Engel 1," is diagrammed in Fig. 3 (our representation). It is based on a theoretical reanalysis of various experimental results in the literature, such as Fry and Bartley's and Levelt's data. The model is essentially characterized by two components. The first part, the weighting component, derives the weights for the two eyes as a function of the luminance distributions in the

monocular fields. The second component, the summation component, derives the binocular brightness as the vector sum of the two weighted responses. This latter part needs little explanation: in the figure, the weighted responses are depicted as  $w_L \psi_L$  and  $w_R \psi_R$ , respectively. Here  $\psi_L$  and  $\psi_R$  are monocular sensation values, computed from the input luminances,  $E_L$  and  $E_R$  via Stevens's power law with exponent value of 0.33. More complicated is the first component which computes the weighting coefficients  $w_L$  and  $w_R$ . The reader is referred to Engel (1969) for details. The heart of this component lies in the derivation of  $V_L$  and  $V_R$ . These are values which express the amount of contour and contrast in the two monocular fields. As was shown by Levelt (1965), monocular contour information is a principle determinant of the share of an eye in binocular brightness averaging. Engel's  $V$  is intended to quantify this contour effect. Given  $V_L$  and  $V_R$ , left and right weighting coefficients  $w_L$  and  $w_R$  are computed as shown in Fig. 3:

$$w_L = \left[ \frac{V_L^2}{V_L^2 + V_R^2} \right]^{1/2}$$

and similarly for  $w_R$ . In this way, we have  $w_L^2 + w_R^2 = 1$ , which, combined with the assumed vector summation, leads to the interesting conclusion that Levelt's law of complementary shares is valid only for squared sensations:

$$\Psi_B^2 = w_L^2 \Psi_L^2 + (1 - w_L^2) \Psi_R^2$$

Indeed, this square root weighting function is unmotivated, and to start with one could as well try the simpler form,

$$w_L = \frac{V_L}{V_L + V_R}$$

which results in  $w_L + w_R = 1$ , as in Levelt's model.

In fact, this is the first simplified version of Engel's model that we will test; it is called "Engel 2." To preserve both the law of complementary shares and the vector summation in Engel's model, the binocular brightness will be defined as follows:

$$\Psi_B = (w_L \Psi_L^2 + w_R \Psi_R^2)^{1/2}$$

This means, however, that it is still the case that the law of complementary shares relates to squared sensations:

$$\Psi_B^2 = w_L \Psi_L^2 + (1 - w_L) \Psi_R^2$$

The only way to relate it to linear sensations is to also change the vector summation component of the model. This additional simplification of Engel's model will be called "Engel 3." The weighting coefficients are as in

“Engel 2,” but  $\Psi_B$  is now defined as  $\Psi_B = w_L \Psi_L + w_R \Psi_R$ , a weighted summation of sensations. It should be noted here that Engel’s arguments for a vector summation are not very specific anyhow. Engel refers to equibrightness curves measured by Ernitz (1966) which are not linear such as Levelt’s. But nonlinearities can be coped with in various ways; vector summation is just one of them. Another approach is to make weighting coefficients dependent on brightness, as we will do in the centroid model.

Let us now return to the other set of models, which originated from Schrödinger’s (1926) paper. According to Schrödinger, the weighting factor for an eye is given by the ratio of the “monocular brightness flux” to the sum of both monocular fluxes. There is an ambiguity here, since Schrödinger uses the term “Helligkeit,” which could also mean “luminance.”

In fact, Livshitz’s (1940) interpretation of Schrödinger’s model is in terms of luminances, whereas in Hurvich and Jameson’s formulation (1966), the model is explicitly stated in terms of brightness magnitudes. The centroid model which we will discuss now is another variant in this tradition. In the version that will be put to test, it is neither luminances nor brightnesses that determine weighting coefficients, but a more neutral “discriminal response,” which is a function,  $f(E)$ , of the input luminance,  $E$ . The function is called “transducer function,” and it is taken to be an empirical issue whether this transducer function is distinct from a psychophysical brightness function. If so, we have to assume a multistage processing model, such as Treisman’s (1970) with a “peripheral processing component,” which is characterized by the transducer function, followed by a “metric processing component” which outputs brightness estimates. In its more general, unquantified version, the centroid model assumes that the weighting coefficients for the two monocular channels are determined by the “strengths” of the stimuli in the two eyes. As in Engel’s model, stimulus strength is assumed to be a function of the amount and distribution of contour and contrast in the stimulus field. In Schrödinger’s tradition, the weighting coefficient for an eye is thus given by the ratio of the strength of the stimulus upon that eye to the sum of both monocular strengths.

In order to quantify the model, we will limit ourselves to the present experimental situation in which only variation of luminance was used. We will leave the possible effects of contours undiscussed. We assume that under these circumstances weighting coefficients are exclusively determined by the discrimininal response  $f(E + c)$ , which is produced at the luminance input,  $E$ . We assume that  $f(E)$  is a power function<sup>1,2</sup> with exponent  $n$ , whereas  $c$  is a very small “background luminance level” which prevents the discrimininal response from becoming zero. This, in view of the fact that our Ss were not dark-adapted, can be expressed in terms of an “equivalent background luminance.”

Finally, we add to the model eye-dominance factors,  $d_L$  and  $d_R$ , which are assumed to be constants for a S, and which are unaffected by stimulus strength.

The version of the centroid model which is put to test is:

$$\Psi_B = \frac{d_L(E_L + c)^n \cdot (E_L + c)^n}{d_L(E_L + c)^n + d_R(E_R + c)^n} + \frac{d_R(E_R + c)^n \cdot (E_R + c)^n}{d_L(E_L + c)^n + d_R(E_R + c)^n},$$

where  $d_L$  and  $d_R$  are dominance factors,  $E_L$  and  $E_R$  are left- and right-field luminance,  $(E_L + c)^n$  and  $(E_R + c)^n$  are left and right discrimininal responses, and  $\Psi_B$  is the binocular discrimininal response. It is obvious that the two weighting factors add to unity. In order to give an impression of the model’s characteristics, we display in Fig. 4 a set of equibrightness curves for  $d_L = d_R$  and  $c = 0$ . The curves differ with respect to exponent  $n$ .

Intuitively, these curves compare very well with Levelt’s (1965) equibrightness curves for exponents between 0.3 and 0.4. It seems, therefore, worthwhile to test the model against the present paired comparison data.

In the following section, we will compare the four interactive models (“Engel 1, 2, 3,” and the centroid model) with our experimental findings.

### Test of the Interactive Models

In order to compare our data with predictions from the three versions of Engel’s model, we will have to compute the autocorrelation functions, which are at the basis of his theory. These functions have to be computed for each of the 49 possible stimulus pairs that could be presented to an eye. For each of the two stimuli in any monocular pair,  $V$  values must be calculated. We exactly followed Engel’s procedure in our computation. The only arbitrary choice concerns the value of the nonzero, but very small, background brightness, as mentioned earlier. Engel used a value of  $10^{-8}$  cd/m<sup>2</sup>, which is extremely low. There are several reasons for us to deviate from this value. The first reason is that this value should represent the effect of stray light (but Engel admits that his value of  $10^{-8}$ , even for that, is too low), as well as of adaptation. In our viewing conditions, adaptation has been substantially higher than in the experimental situations analyzed by Engel.

At this point, we must remark that adaptation conditions have hardly ever been under control in binocular brightness experiments. A second reason is that recent measurements (Marks, 1973) of equivalent intensity of intrinsic light point to values as high as 1-1.4 photopic trolands, corresponding to an equivalent stimulus intensity of about 0.08 – 0.12 cd/m<sup>2</sup> for a pupil diameter of 4 mm. This differs by more than  $10^6$  from Engel’s parameter. Thirdly, from the analysis of

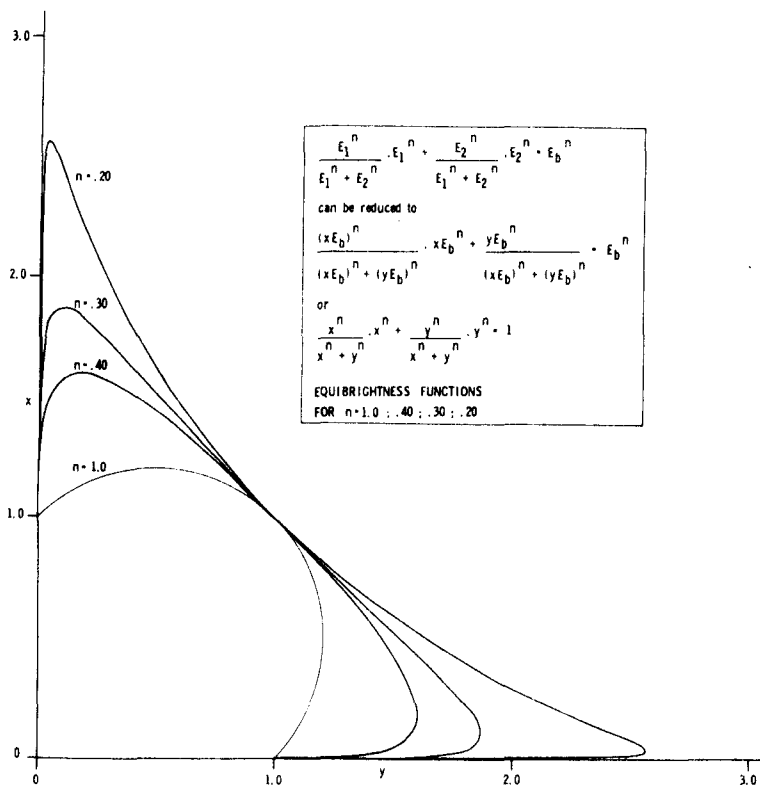

Fig. 4. Equibrightness functions for the most simple form of the centroid model. If eye-dominance factors are involved, the curves are simply tilted over the 1,1 point.

the centroid model (see below), we were able to estimate background luminance at somewhere from  $10^{-2}$  to  $10^{-4}$  cd/m<sup>2</sup>. This will be discussed later. Finally, for

one S (W.), we tested the "Engel 1 and 3" models for several background values down to  $10^{-6}$  cd/m<sup>2</sup>. It turned out that the fit of the models was best at about

Table 5

		ENGEL 1			ENGEL 2			ENGEL 3			CENTROID		
		data			data			data			data		
		-1	0	+1	-1	0	+1	-1	0	+1	-1	0	+1
theory	-1	1073	22	65	1102	18	44	1104	18	41	1120	16	30
	0	44	29	8	42	26	6	42	27	6	38	23	8
	+1	149	23	988	122	30	1012	120	29	1014	108	35	1023
		c = 10 <sup>-4</sup> ; n = .33 subj: W			c = 10 <sup>-4</sup> ; n = .33 subj: W			c = 10 <sup>-4</sup> ; n = .33 subj: W			c = 10 <sup>-4</sup> ; n = .44 d <sub>L</sub> = 1.0; Subj. W		
		ENGEL 1			ENGEL 2			ENGEL 3			CENTROID		
		data			data			data			data		
		-1	0	+1	-1	0	+1	-1	0	+1	-1	0	+1
theory	-1	982	3	175	1016	2	146	1025	2	136	1061	5	110
	0	28	5	48	25	6	42	25	6	44	19	0	30
	+1	126	2	1032	95	2	1067	86	2	1075	56	5	1115
		c = 10 <sup>-4</sup> ; n = .33 Subj. S			c = 10 <sup>-4</sup> ; n = .33 Subj. S			c = 10 <sup>-4</sup> ; n = .33 Subj. S			c = 10 <sup>-4</sup> ; n = .22 d <sub>L</sub> = 1.06; Subj. S		



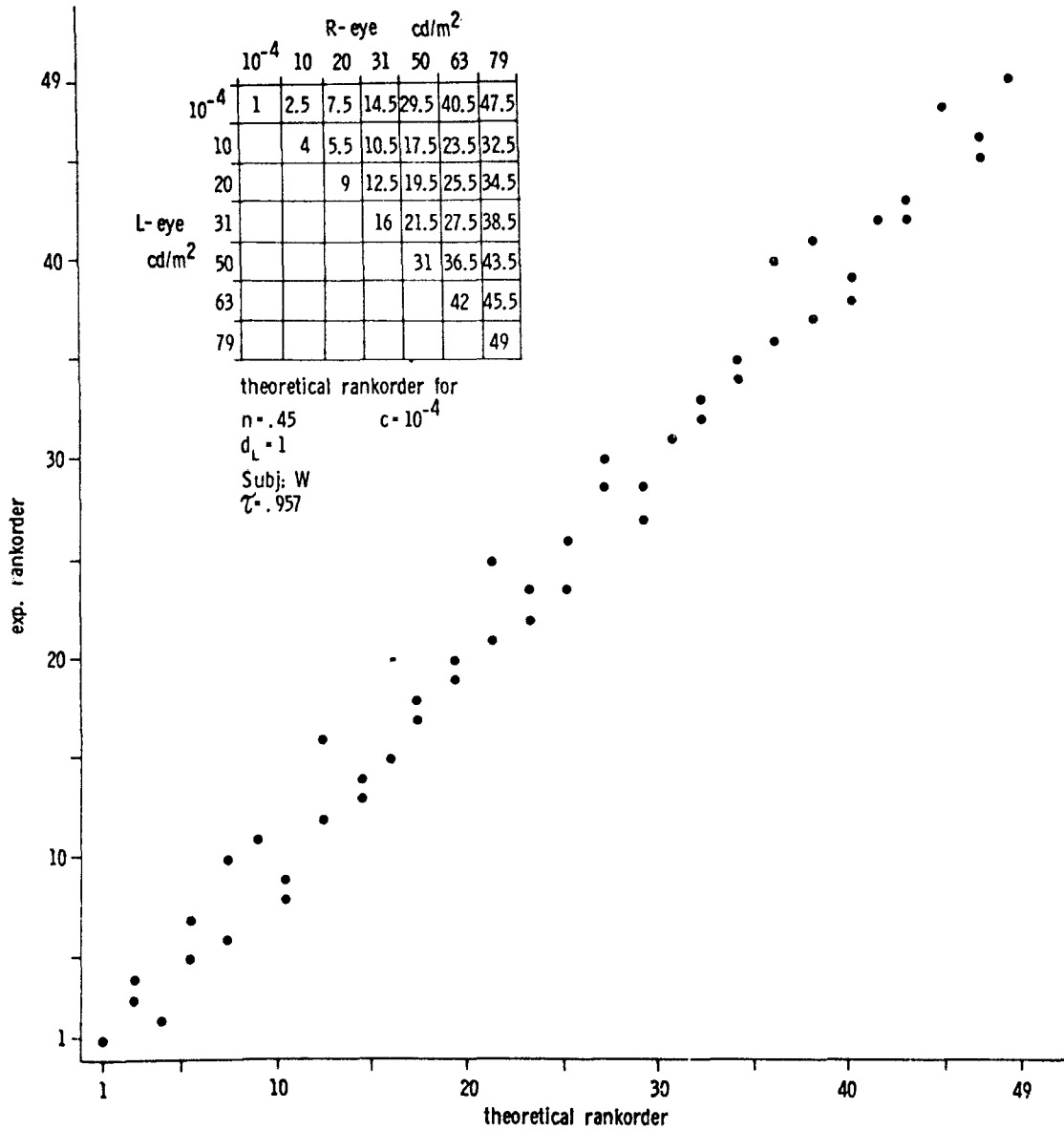

Fig. 5.

$10^{-4}$  cd/m<sup>2</sup>. It thus seemed to be only honest to choose that value for a test of the Engel models. For the other free parameter, the exponent of the brightness scale, we used Engel's own estimate of 0.33.

With these coefficients, we could compute the ordinal prediction for every pair in the 49 x 49 matrix of paired comparisons. These were "left dominates right" (-1), the reverse (1), or "equal" (0). The fit with the experimental data can therefore be represented in a 3 x 3 table. One can find the result of these tabulations in Table 5.

The table also gives the fit for the centroid model, the computation of which is described now. We started from 7 x 7 experimental matrices (Table 1), since, contrary to the Engel models, left and right stimuli in a monocular pattern are independent in the centroid model. The  $\Psi_B$

values for all 49 combinations were determined according to Eq. 1 for different values of n and d. The background value, c, was given the same values as for the test of the Engel models. As mentioned, we have independent reasons for this choice, which we will discuss presently. We determined the n,d pairs for which the solution was optimal, the criterion being that the value of the Kendall rank-order correlation between theoretical and experimental ordering of  $\Psi_B$  values is maximized. From there, we could go back to the prediction for all 49 x 49 paired comparisons, and these are compared with the actual data for Ss S. and W. in Table 5. It is this same procedure which was used to determine the c value. The idea was the following: Of the three parameters, n, d, and c, only the first two are of significance if we consider the limited sets of data,

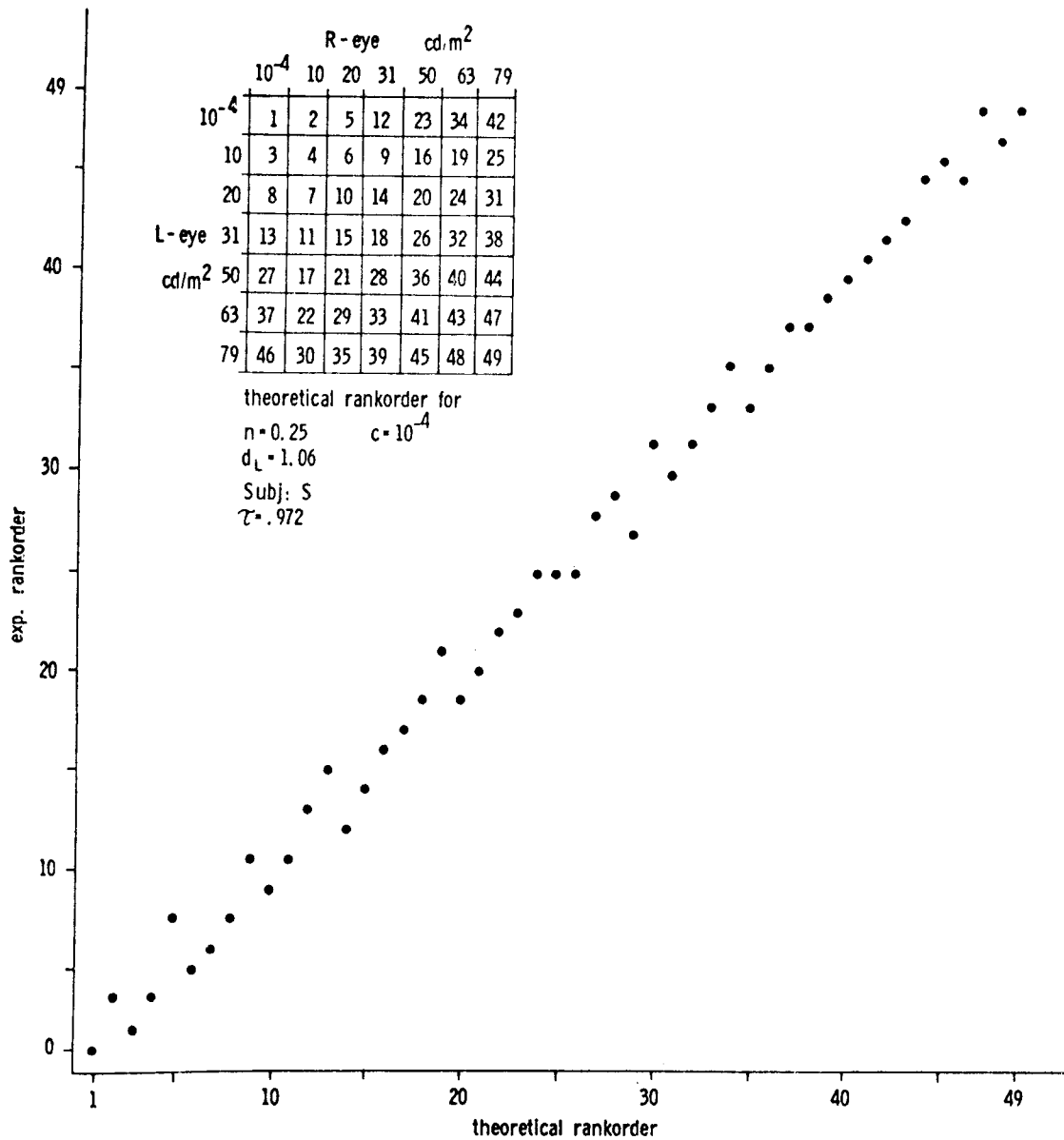

Fig. 6.

where the null stimulus is excluded. These data were presented in Table 3. For these data, the analysis of the centroid model will be unaffected by the choice of  $c$  if we may assume that  $c$  is small in comparison to the smallest real stimulus value. For  $c = 0$ , we determined optimal  $w$  and  $n$  pairs for these data, in the just-mentioned manner, and these values we used preliminarily in the analysis of the  $7 \times 7$  data matrices. This latter was done for various choices of  $c$ , and it turned out that optimal fits were found for  $c$ , ranging from  $10^{-2}$  to  $10^{-4}$   $\text{cd}/\text{m}^2$ . From Table 4, it appears that the fit of the models increased from "Engel 1" to centroid, for these particular choices of the parameters. We also computed the predictions of the Engel (1) model for  $n = .44$ , and compared these to the experimental data of S W. The fit turned out to be worse than for  $n = .33$ .

In the discussion, we will return to a general comparison of the Engel models and the centroid model; now we limit ourselves to a consideration of the absolute levels of the fit. At first glance, the number of false predictions is still substantial. This led us to consider the type of prediction errors. We checked various possibilities. Initially, we considered the possibility that a sizeable number of the errors would involve the null stimulus. However, it turned out that the percentage of errors in which the null stimulus was involved did not differ from the comparable cases where the null stimulus was excluded. A second source of errors might have been some asymmetry between left and right halves of the retinae. It is immediately obvious from the  $3 \times 3$  tables that, for S S., the right half fields are dominant, whereas the inverse is true for S W. This finding cannot be explained by an eye-dominance factor

for the whole eye; it must, rather, be ascribed to a kind of hemispherical dominance, or to different eye dominances for left and right hemispheres, respectively. Such phenomena have been observed before (Crovitz, 1964) and are known as Köllner effects, after Köllner (1914), who found hemianopia effects in binocular color rivalry. In spite of various detailed efforts, we have not been able to find any other systematic source of errors, so we are inclined to conclude that it is less the centroid model than experimental noise which causes the prediction errors. Another way of arguing that this is a safe conclusion is to show that the errors are typically quite small. This can be seen in Figs. 5 and 6, in which the ordering of theoretical binocular discriminial effects is plotted against the ordering of the experimental data. Order inversions are nonsystematic and quite small. These figures present in a summary fashion the accuracy of the centroid model.

### DISCUSSION

The additivity analysis of our experimental data clearly confirmed Levelt's earlier conclusion that for nonlow luminance values the binocular discriminial response can be described by a linear additive combination of the monocular luminances.

A more complete model of binocular brightness, however, has to cope not only with the full brightness range for which that additivity is not valid, but also with the reality that discriminial responses are hardly ever linear. Both Engel's model and theories in the Schrödinger tradition can in principle cope with both these problems. Engel's is the only model which in addition gives a detailed quantitative account of the effect of monocular luminance distributions on the binocular combination function. At the same time, his theory, diagrammed in Fig. 3, is quite complicated. Both the derivation of the weighting coefficients and the vector summation rule are not simple assumptions. It is not surprising to find that simplifications of Engel's (1969) model at these two points lead to better fits with the data. The centroid model does not handle contours in a similar general way. In fact, quantitative predictions were only possible for the present experimental situation in which all stimuli were identical in terms of contours. Further extensions of the model have to be made for cases where contours are different for the two eyes, such as in Levelt's (1965) experiments. It should be mentioned, however, that it is also unclear how Engel's model would handle these results: as far as we can see, several additional assumptions have to be made, for instance with respect to the "grain" of the retinal mosaic. Whether that will lead to acceptable predictions is still an open issue.

For the present data, the centroid model's predictions are clearly better. But this should also be interpreted with much care. The centroid model had two additional parameters: the exponent,  $n$ , and the eye-dominance

factor,  $d$ . The latter factor is not accounted for in Engel's model, whereas the former is fixed at 0.33. We see no deep reason to fix the brightness exponent at this magic level; it is certainly more realistic to treat it as a free parameter within a certain range. For our Ss, the  $n$  values ranged from 0.22 to 0.44; nobody would be surprised to find such values in a magnitude estimation or similar experiment.

This brings us, finally, to the question of whether our discriminial response,  $\Psi_B$ , can be considered as a brightness function or not; in the latter case, we have to add an additional "metric processing component" which transforms discriminial responses in brightness judgments. In the former case, we can agree with Engel that it is monocular "sensations" or "brightnesses" which are combined binocularly. (The quotes indicate the arbitrariness of the definitions of these terms.) The fact that our exponents are clearly in the range of the exponents found in direct scaling procedures indicates that the centroid model can be expected as well to account for binocular direct estimation data. Though this has still to be demonstrated, it would mean that no additional component in Treisman's (1970) sense is required to handle both types of data.

### REFERENCES

- Crovitz, H. F. Retinal locus in tachistoscopic binocular color rivalry. *Perceptual & Motor Skills*, 1964, 19, 808-810.
- De Silva, H. R., & Bartley, S. H. Summation and subtraction of brightness in binocular perception. *British Journal of Psychology*, 1930, 20, 241-250.
- Engel, G. R. The visual process underlying binocular brightness summation. *Vision Research*, 1967, 7, 753-767.
- Engel, G. R. The autocorrelation function and binocular brightness mixing. *Vision Research*, 1969, 9, 1111-1130.
- Ernitz, T. Binocular brightness summation. Unpublished masters thesis, University of Western Ontario, 1966.
- Fechner, G. T. Ueber einige Verhältnisse des binocularen Sehens. *Abhandlungen der königlichen sächsischen Gesellschaft für Wissenschaften*, 1861, 5, 336-564.
- Fry, G. A., & Bartley, S. H. The brilliance of an object seen binocularly. *American Journal of Ophthalmology*, 1933, 16, 687-699.
- Hering, E. *Outlines of a theory of the light sense*. Cambridge, Mass: Harvard University Press, 1964.
- Hurvich, L. M., & Jameson, D. *The perception of brightness and darkness*. Boston: Allyn & Bacon, 1966.
- Köllner, H. Das funktionelle Ueberwiegen der nasalen Netzhauthälften in gemeinschaftlichen Sehefeld. *Archiv für Augenheilkunde*, 1914, 76, 153-164.
- Krantz, D. H., Luce, R. D., Suppes, P., & Tversky, A. *Foundations of measurement*. New York: Academic Press, 1971.
- Levelt, W. J. M. *On binocular rivalry*. The Hague: Mouton, 1965.
- Livshitz, N. N. On the laws of binocular colour mixture. *Comptes Rendus (Doklady) de l'Académie des Sciences de l'URSS*, 1940, 28, 429-432.
- Luce, R. D., & Green, D. M. A neural timing theory for response times and the psychophysics of intensity. *Psychological Review*, 1972, 79, 14-57.
- MacLeod, D. I. A. The Schrödinger equation in binocular brightness combination. *Perception*, 1972, 1, 321-324.
- Marks, L. E. Brightness and equivalent intensity of intrinsic light. *Vision Research*, 1973, 13, 371-382.
- Roskam, E. E. Ch. I. *Metric analysis of ordinal data in psychology: Modules and numerical methods for metric analysis of conjoint ordinal data in psychology*. Voorschoten: VAM, 1968.

- Roskam, E. E. Ch. I., & Van Gilst, W. 'Addit'007/02. Department of Psychology Computer Bulletin, Nijmegen University, 1967 (revised version, 1971).
- Schrödinger, E. *Müller-Pouillet's Lehrbuch der Physik*. 11. Auflage, Zweiter Band. Braunschweig: Vieweg, 1926
- Sherrington, C. S. *The integrative action of the nervous system*. New Haven: Yale University Press, 1906.
- Teller, D. Y., & Galanter, E. Brightnesses, luminances and Fechner's paradox. *Perception & Psychophysics*, 1967, 2, 297-300.
- Thijssen, J. M., & Vendrik, A. J. H. Differential luminance sensitivity of the human visual system. *Perception & Psychophysics*, 1971, 10, 58-64.
- Treisman, M. A statistical decision model for sensory discrimination which predicts Weber's law and other sensory laws. *Perception & Psychophysics*, 1966, 1, 203-230.
- Treisman, M. Brightness contrast and the perceptual scale. *British Journal of Mathematical & Statistical Psychology*, 1970, 23, 205-230.

## NOTES

1. The special choice of a powerlike transducer function is not essential for this model. Logarithmic functions can also be used. We do prefer power-form functions, because experimental and theoretical studies point to this kind of transducer function. Treisman (1966, 1970) and Thijssen and Vendrik (1971) propose power-form transducer functions on theoretical grounds. In a completely different kind of approach, Luce and Green (1972) prefer power functions above logarithmic functions in a study on a neural timing model for the psychophysics of intensity.

2. While writing this paper, we received MacLeod's (1972) paper, which presented essentially the same model, using logarithmic transducer functions.

(Received for publication June 8, 1973;  
revision received February 8, 1974.)