

---

# The influence of subsurface carbon on the selectivity in the hydrogenation reaction of 1-pentyne over Pd catalysts



FHI; Dep. of  
Chemical Physics



INSTITUTE  
of  
ISOTOPE



UNIVERSITY  
of  
CAMBRIDGE



UNIVERSITY  
of  
GLASGOW

# Contributors

---

- Detre Teschner, Elaine Vass, Michael Hävecker, Spiros Zefeiratos, Péter Schnörch, Axel Knop-Gericke, Robert Schlögl
- Aidan M. Doyle, Shamil K. Shaikhutdinov, Hajo Freund
- Mounir Chamam, Attila Wootsch
- Arran S. Canning, Jonathan J. Gamman, S. David Jackson
- James McGregor, Lynn F. Gladden

# Athena: ADVANCED TECHNOLOGY IN CATALYTIC CHEMISTRY AND ENGINEERING FOR NOVEL APPLICATIONS

## OBJECTIVE

TO BE ABLE TO ADD OR REMOVE HYDROGEN OR OXYGEN TO A GIVEN MOLECULE WITH HIGH ACTIVITY AND SELECTIVITY.



Hydrogenation  
Dehydrogenation  
Selective Oxidation



Max-Planck-Gesellschaft

Fritz-Haber-Institute

Department of Chemical Physics

RESEARCH GROUPS





[www.chem.gla.ac.uk/athena/](http://www.chem.gla.ac.uk/athena/)

# Introduction

---

## Literature

carbon laydown  selective hydrogenation  
"similar" catalysts  different activity & selectivity  
(structure sensitivity?)

Selectivity issue: what defines selectivity?

# Model of overlapping TDS peaks

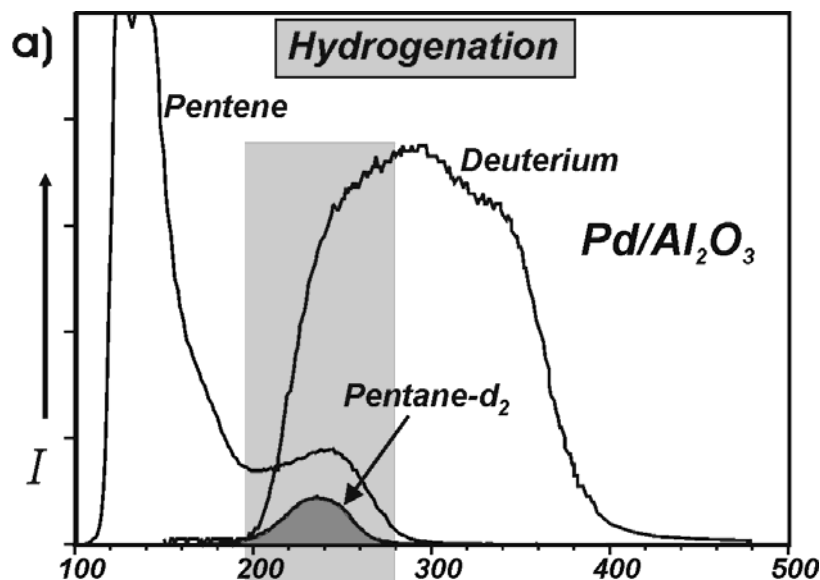

Pentenes to pentane

Hydrogenation  
in the presence of  
subsurface H  
[Pd particles]

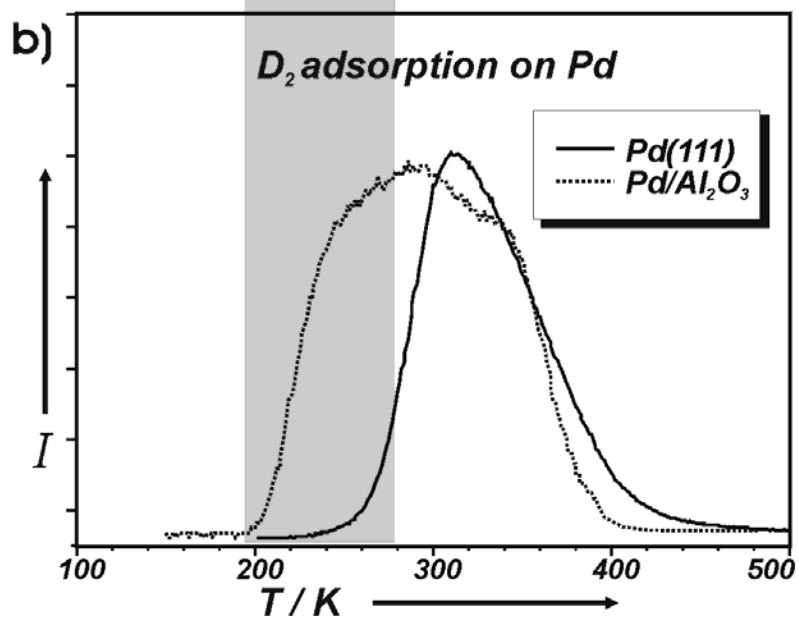

No hydrogenation  
without  
subsurface H  
[Pd(111)]

# Acetylene hydrogenation (TDS)

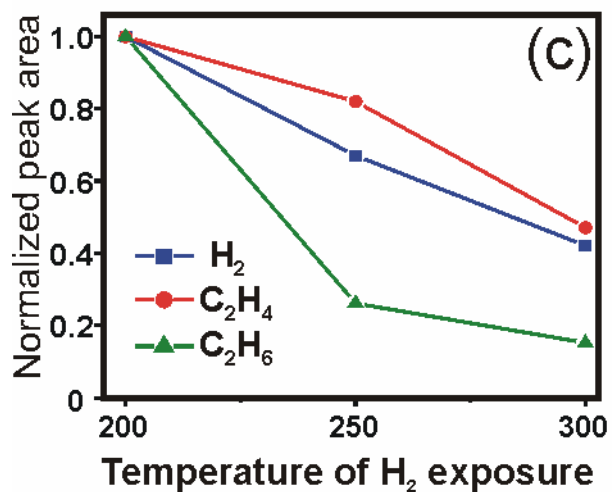
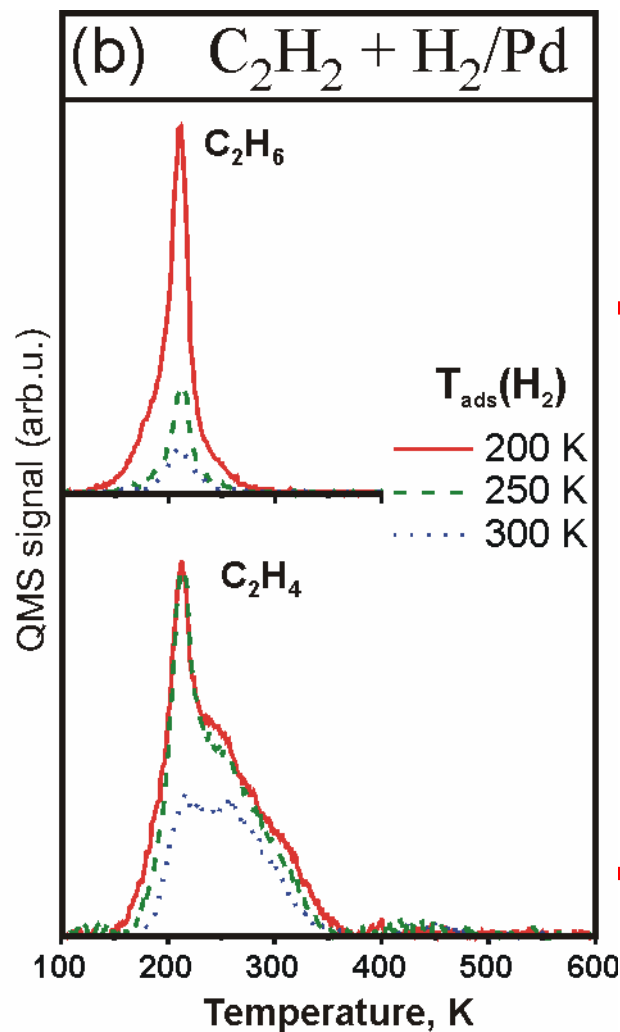
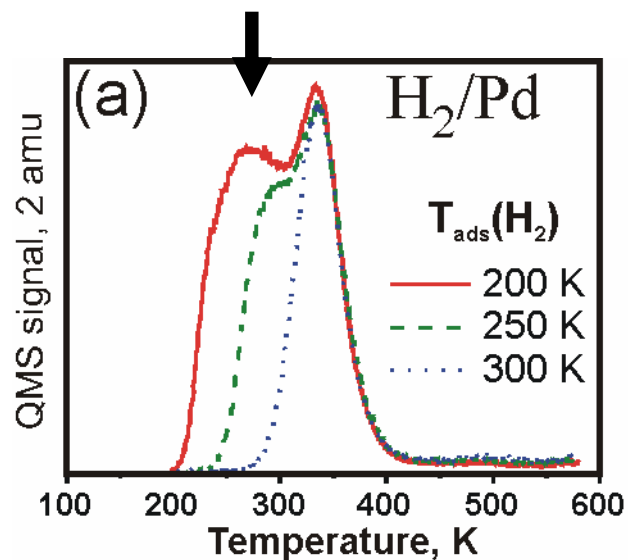

Subsurface H  
at low  $T_{\text{ads}}$

Total hydrogenation  
decreases strongly  
without  
subsurface H

# Hydrogenation (TDS)

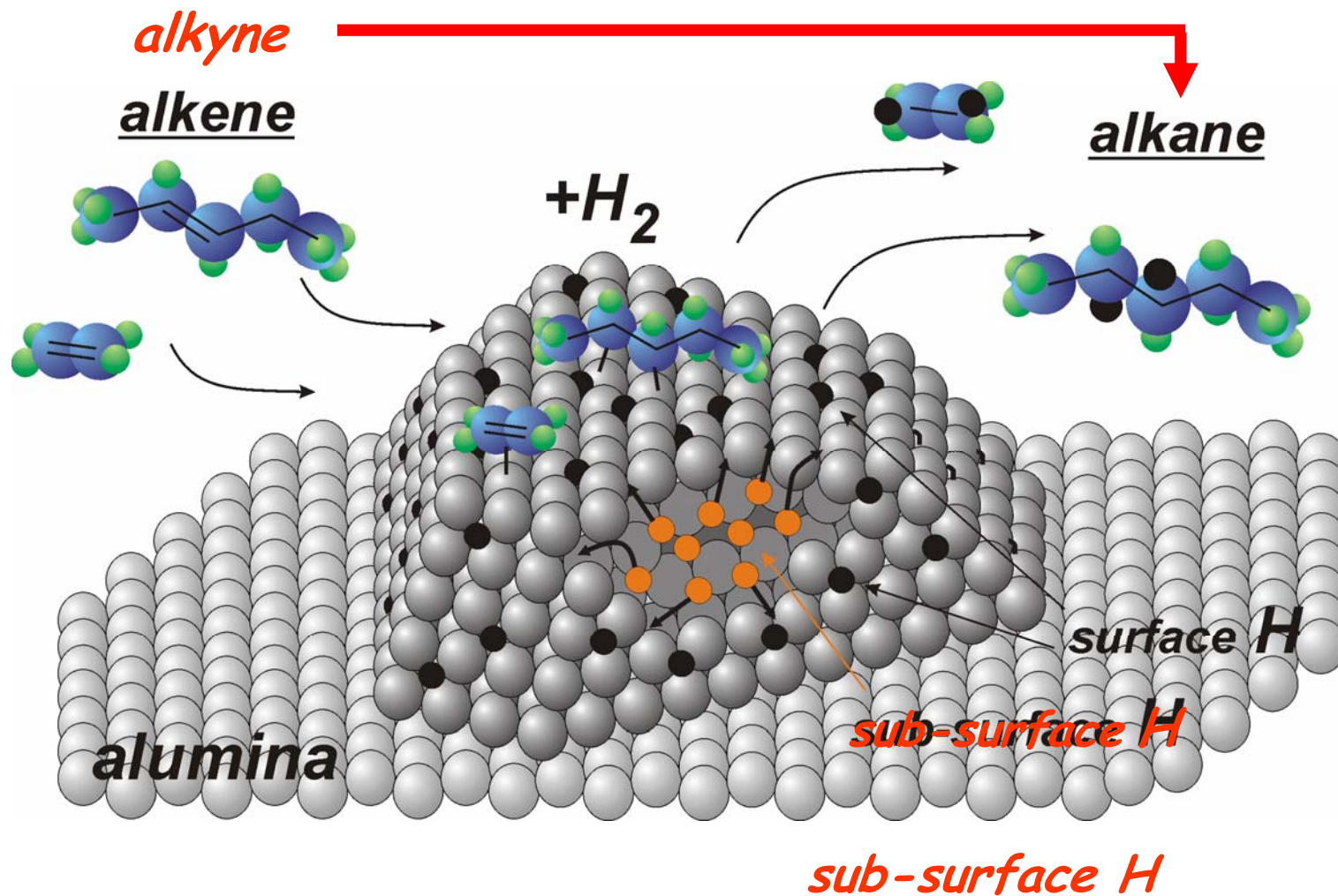

# Summary

---

1. Subsurface H: effective for alkene-to-alkane but also for alkyne-to-alkane transformation



# Pulse experiments 1-pentyne Adsorption

(After H<sub>2</sub> pretreatment)

1%Pd/Al<sub>2</sub>O<sub>3</sub>

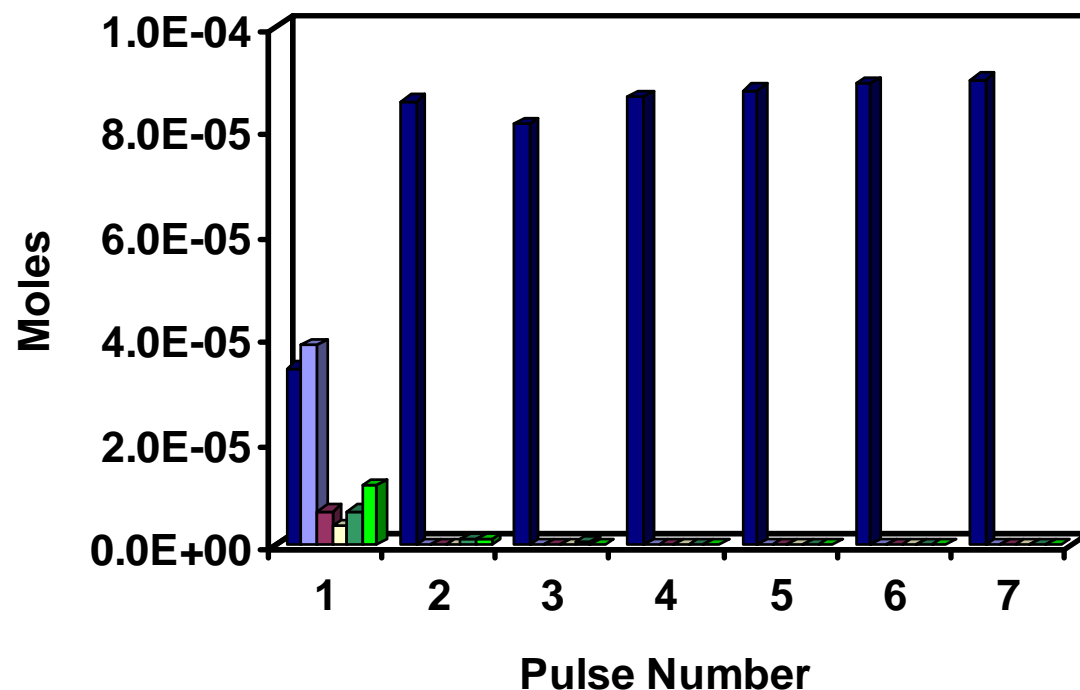

- First pulse shows activity
- 65% conversion
  - 38.5% 1-pentene
  - 6.5% *trans*-2-pentene
  - 3.5% *cis*-2-pentene
  - 6.5% pentane
  - 11.5% Unknown

■ 1-pentyne      ■ 1-pentene      ■ trans-2-pentene  
■ cis-2-pentene      ■ pentane      ■ unknown

H<sub>needed</sub>/Pd<sub>total</sub> ratio: 13-to-1      Source of H?      → Spillover

# Summary

---

1. Subsurface H: effective for alkene-to-alkane but also for alkyne-to-alkane transformation
2. Surface H: could be selective (spillover)

# Hydrogenation

- 1-Pentyne hydrogenation over 1% Pd/Al<sub>2</sub>O<sub>3</sub> in a **closed loop-reactor**, t=5 min.  
(after repeated runs at each condition)

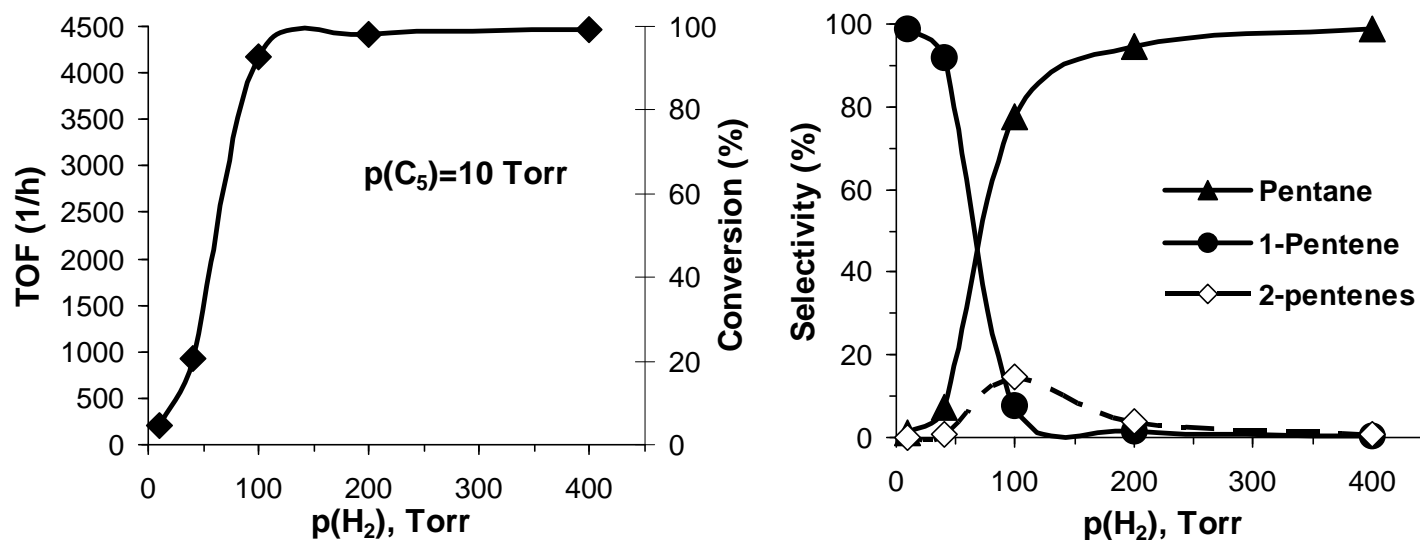

- 1-Pentyne hydrogenation over 1% Pd/Al<sub>2</sub>O<sub>3</sub> in **continuous flow**

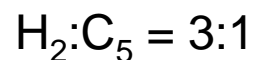
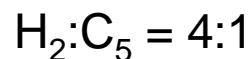

**total** hydrogenation

**selective** hydrogenation

# Summary

---

1. Subsurface H: effective for alkene-to-alkane but also for alkyne-to-alkane transformation
2. Surface H: could be selective (spillover)
3. Different reaction orders in the different selectivity regimes & Abrupt changes between regimes

## During TEOM experiment

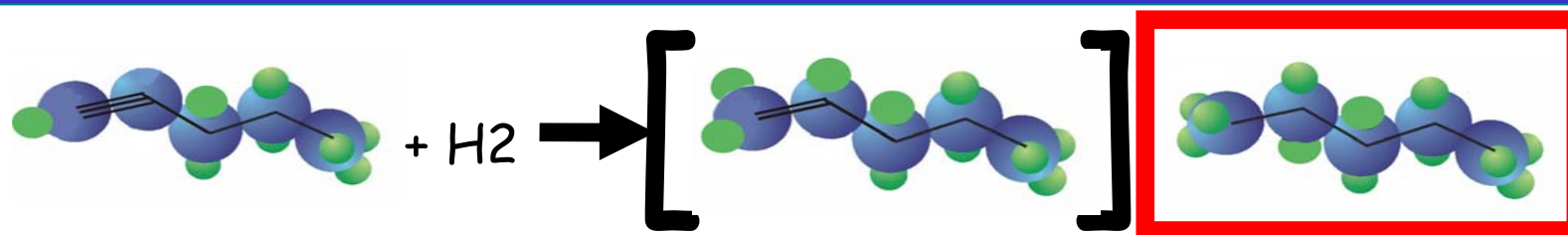

	40 mins				170 mins			
	1-pentyne	1-pentene	2-pentenes	n-pentane	1-pentyne	1-pentene	2-pentenes	n-pentane
<b>Pd/Al<sub>2</sub>O<sub>3</sub>, 100 % H<sub>2</sub></b>	trace	trace	trace	<b>100</b>	trace	trace	trace	<b>100</b>
<b>Pd Black, 100 % H<sub>2</sub></b>	<b>0.1</b>	trace	<b>0.1</b>	<b>99.8</b>	<b>3.6</b>	<b>0.5</b>	<b>11.3</b>	<b>84.5</b>
<b>Pd Black, 5 % H<sub>2</sub></b>	<b>58.7</b>	<b>40.1</b>	trace	<b>1.2</b>	<b>42.8</b>	<b>54.7</b>	<b>0.2</b>	<b>2.3</b>
<b>Al<sub>2</sub>O<sub>3</sub>, 100 % H<sub>2</sub></b>	<b>81.1</b>	<b>16.2</b>	<b>0.7</b>	<b>2.0</b>	<b>74.9</b>	<b>22.4</b>	<b>0.7</b>	<b>1.9</b>
<b>Quartz Wool, 358 K</b>	<b>81.6</b>	<b>17.1</b>	<b>0.2</b>	<b>1.1</b>	-	-	-	-
<b>Quartz Wool, 303 K</b>	<b>89.2</b>	<b>10.6</b>	trace	<b>0.3</b>	-	-	-	-

# During TEOM experiment

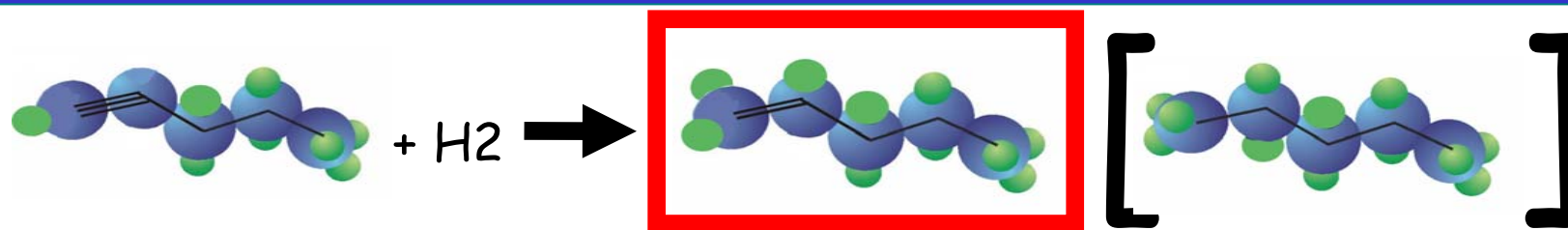

	40 mins				170 mins			
	1-pentyne	1-pentene	2-pentenes	n-pentane	1-pentyne	1-pentene	2-pentenes	n-pentane
<b>Pd/Al<sub>2</sub>O<sub>3</sub>, 100 % H<sub>2</sub></b>	trace	trace	trace	<b>100</b>	trace	trace	trace	<b>100</b>
<b>Pd Black, 100 % H<sub>2</sub></b>	<b>0.1</b>	trace	<b>0.1</b>	<b>99.8</b>	<b>3.6</b>	<b>0.5</b>	<b>11.3</b>	<b>84.5</b>
<b>Pd Black, 5 % H<sub>2</sub></b>	<b>58.7</b>	<b>40.1</b>	trace	<b>1.2</b>	<b>42.8</b>	<b>54.7</b>	<b>0.2</b>	<b>2.3</b>
<b>Al<sub>2</sub>O<sub>3</sub>, 100 % H<sub>2</sub></b>	<b>81.1</b>	<b>16.2</b>	<b>0.7</b>	<b>2.0</b>	<b>74.9</b>	<b>22.4</b>	<b>0.7</b>	<b>1.9</b>
<b>Quartz Wool, 358 K</b>	<b>81.6</b>	<b>17.1</b>	<b>0.2</b>	<b>1.1</b>	-	-	-	-
<b>Quartz Wool, 303 K</b>	<b>89.2</b>	<b>10.6</b>	trace	<b>0.3</b>	-	-	-	-

# During TEOM experiment

## Pd Black

Reaction with 100% H<sub>2</sub>

Reaction with 5% H<sub>2</sub>

Mass change [micro g / mg catalyst]

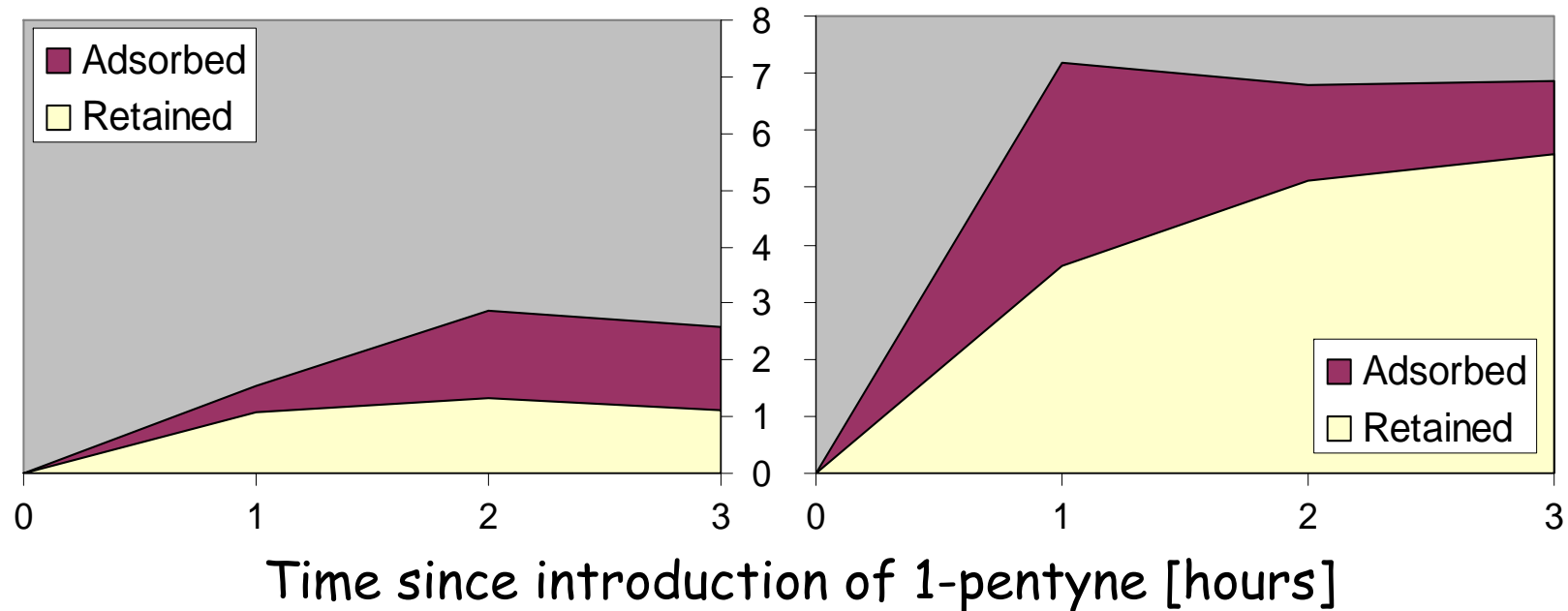

Up to x5 more carbon is retained in the selective hydrogenation regime

# Summary

---

1. Subsurface H: effective for alkene-to-alkane but also for alkyne-to-alkane transformation
2. Surface H: could be selective (spillover)
3. Different reaction orders in the different selectivity regimes & Abrupt changes between regimes
4. C uptake is significantly more in the selective regime



# In situ XPS system

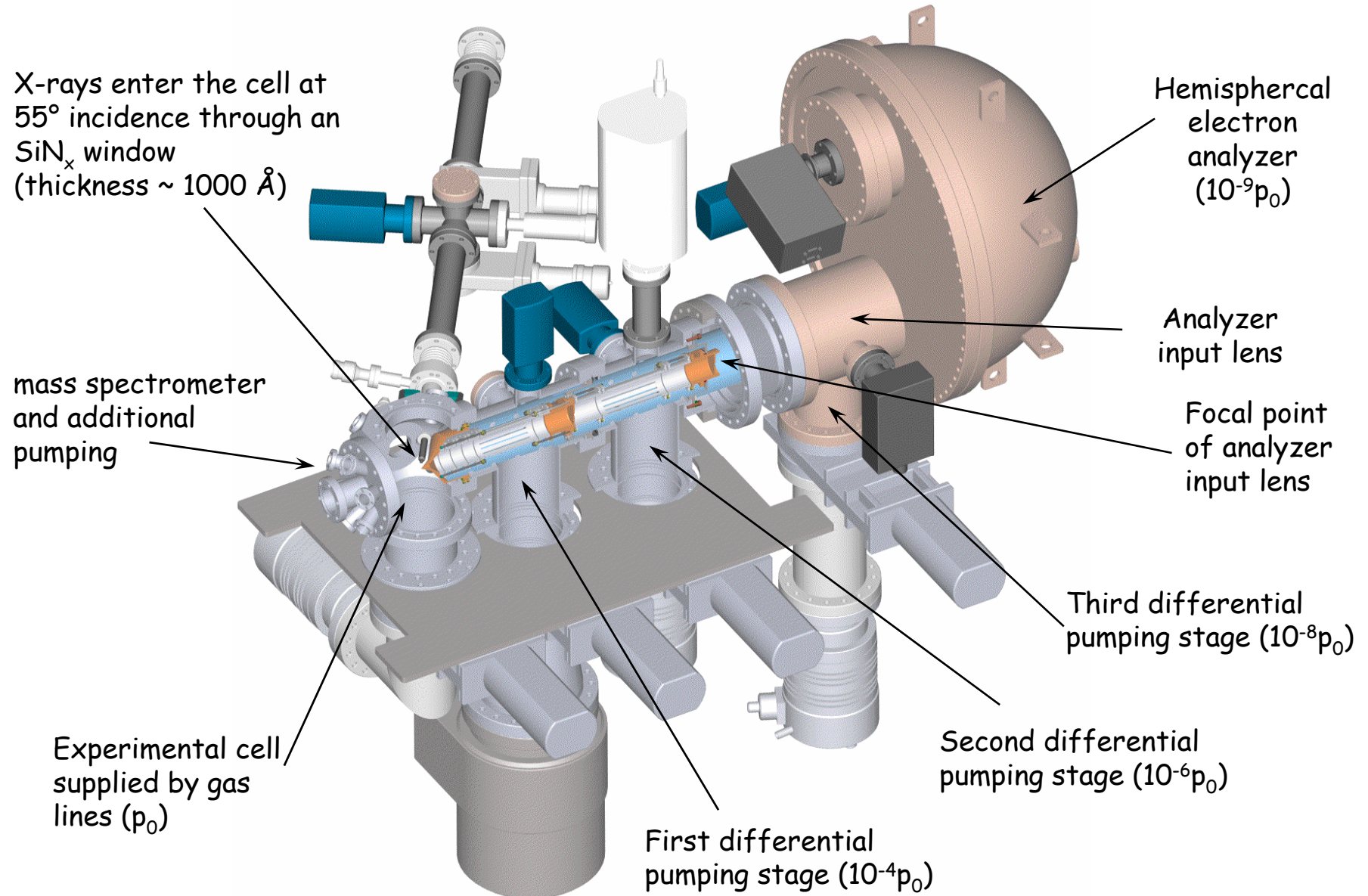

## Reaction in the mbar p region (in-situ XPS)

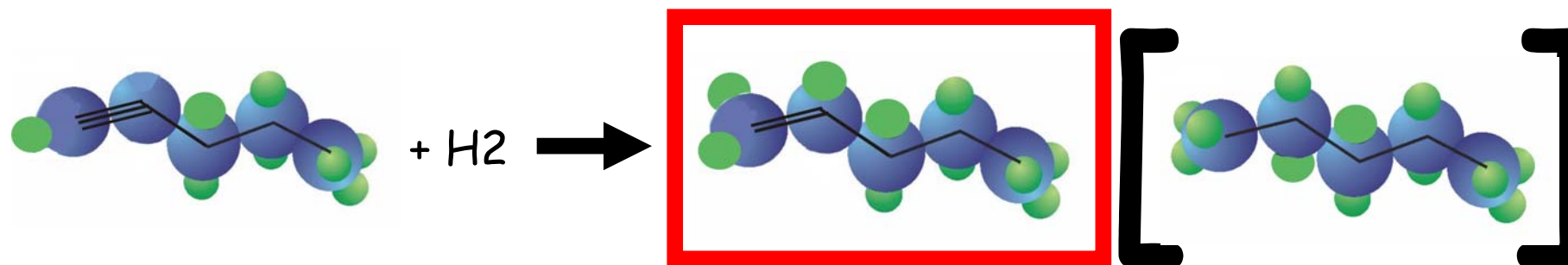

	5% Pd/CNT	3% Pd/Al <sub>2</sub> O <sub>3</sub>	Pd foil	Pd(111)
Conversion [%]	~ 10	~5	~2.5	<1
Selectivity Pentene [%]	~95	~80	~98	100
Selectivity Pentane [%]	~5	~20	~2	-

Reaction conditions: C<sub>5</sub>/H<sub>2</sub> = 1:9, 1 mbar, 358 K

# In-situ XPS: Pd 3d ( $h\nu$ : 720 eV)

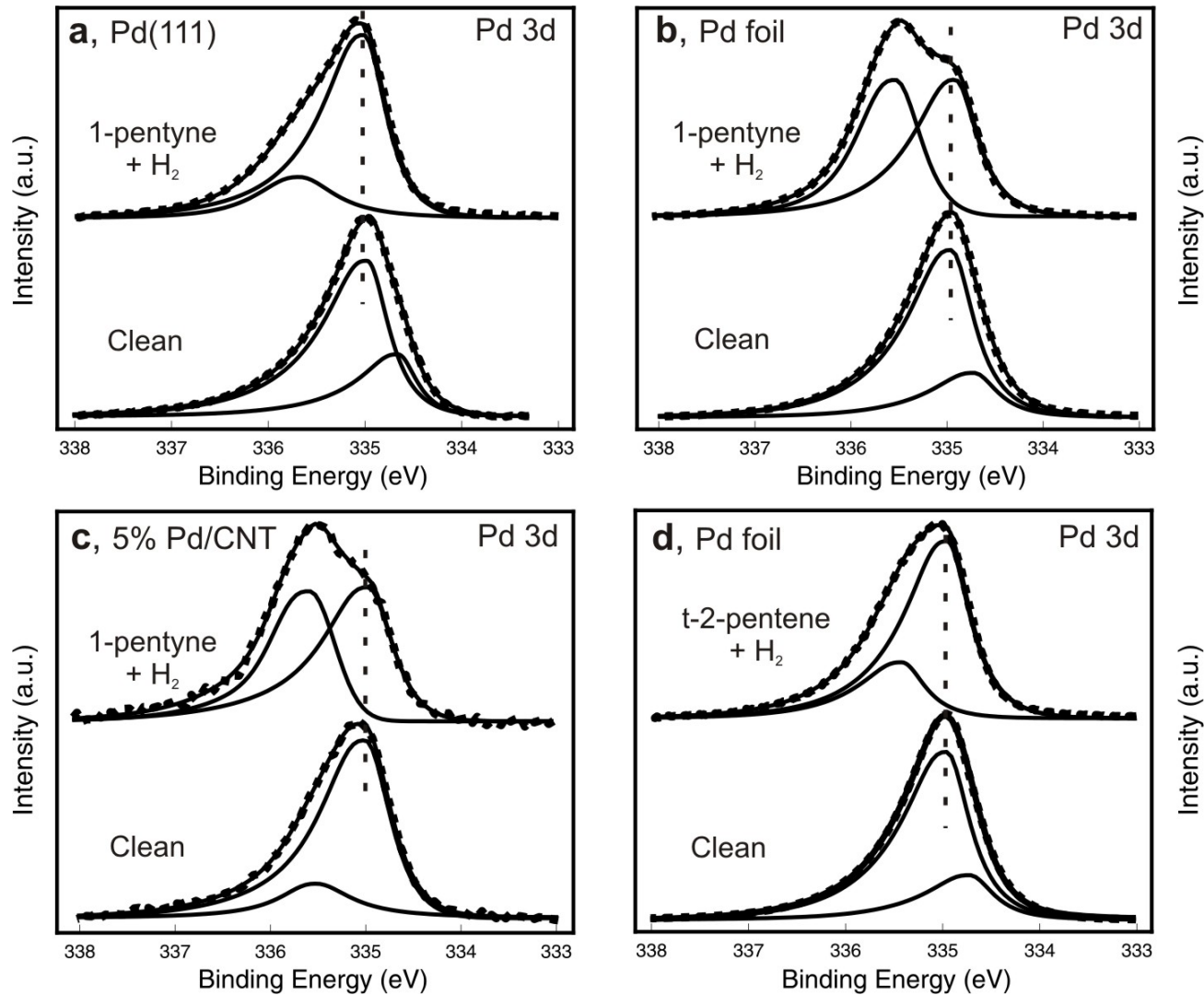

# In-situ XPS: Pd 3d depth profiling

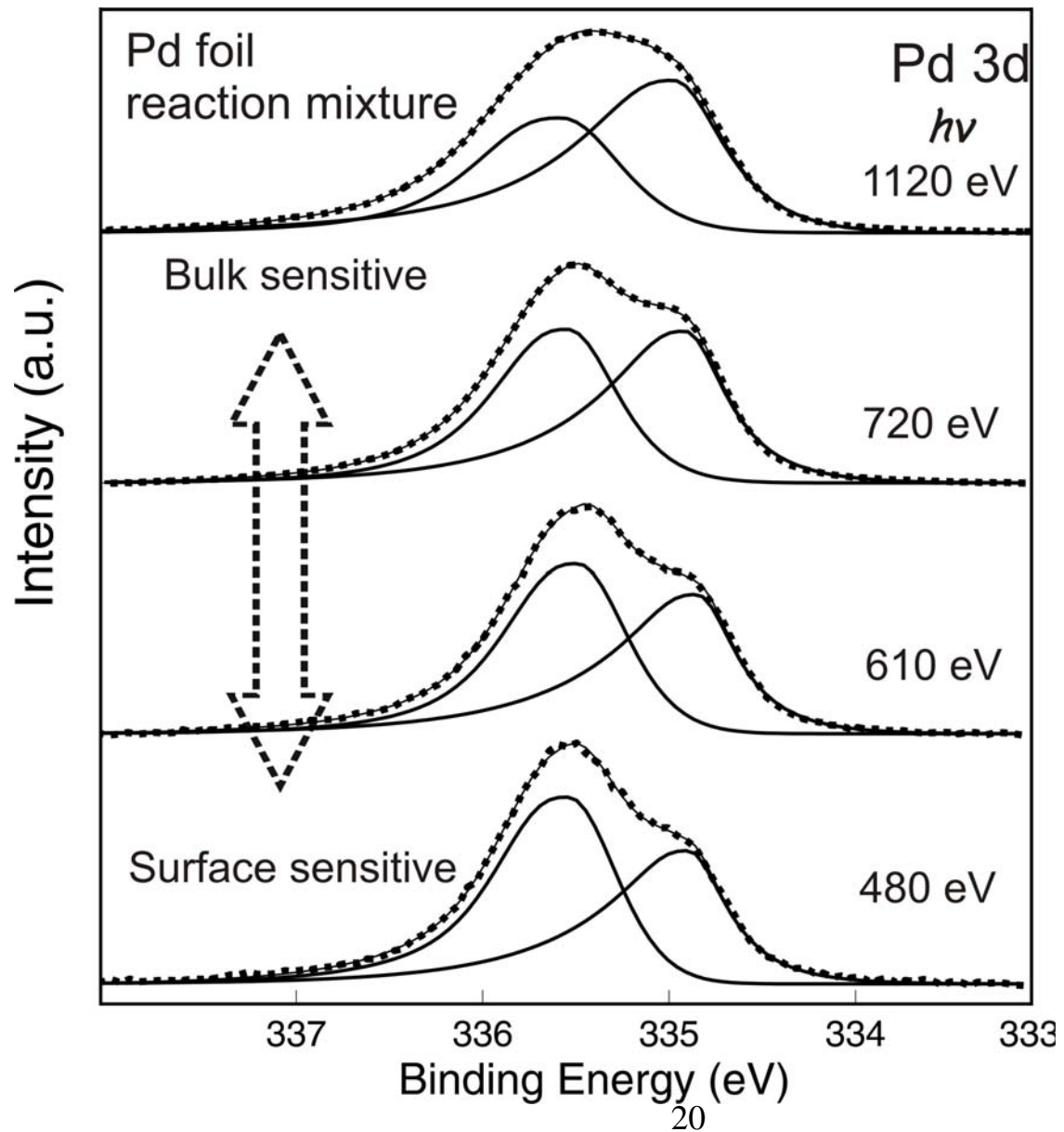

Not only  
adsorbate-induced  
surface core level  
shift!

But on-top location!

# In-situ XPS: C1s (Switching off experiments)

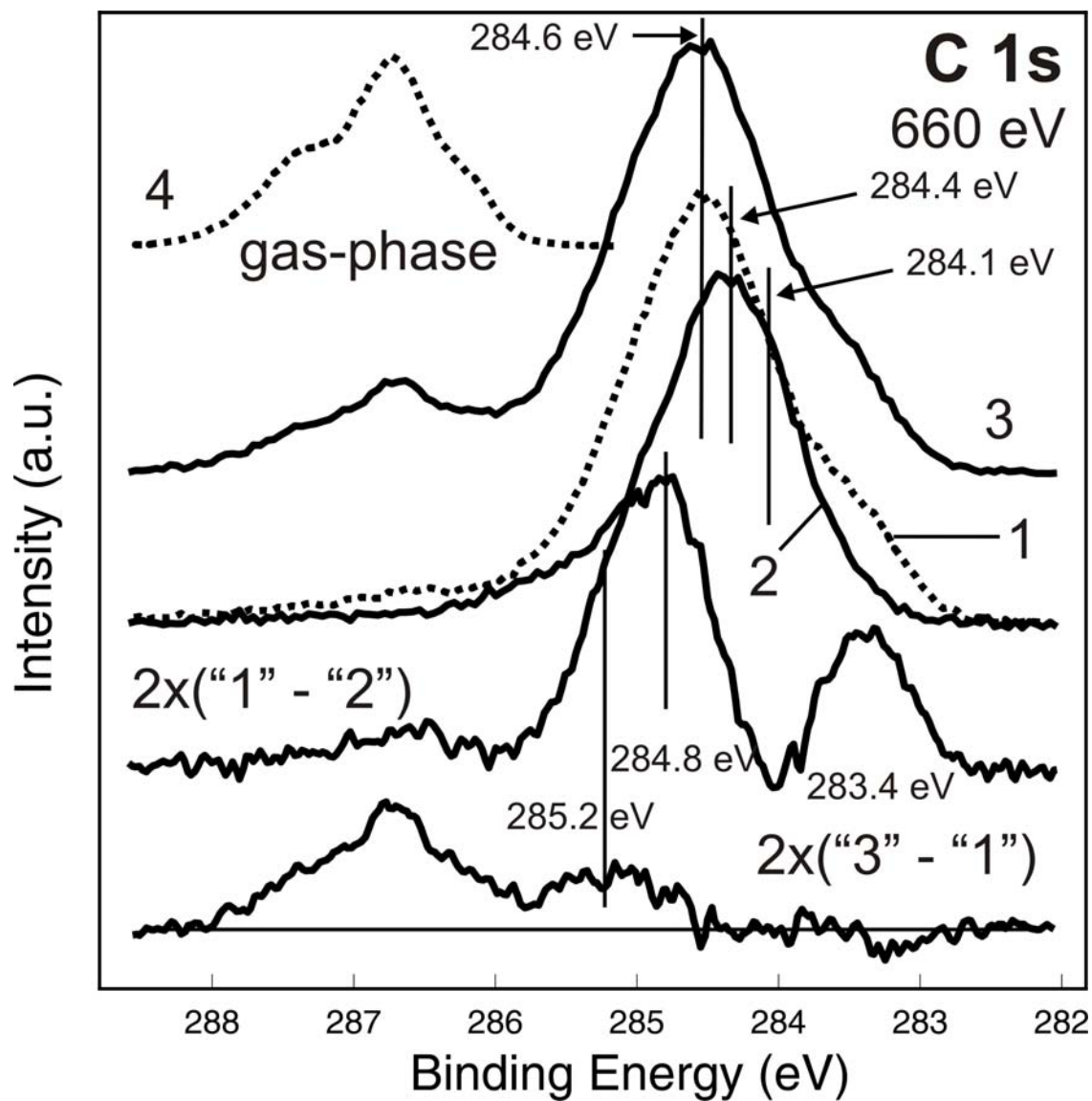

- 1: reaction mix.
- 2: C5 off
- 3: H2 off
- 4: C5 gas-phase

# In-situ XPS: Pd 3d (Switching off experiments)

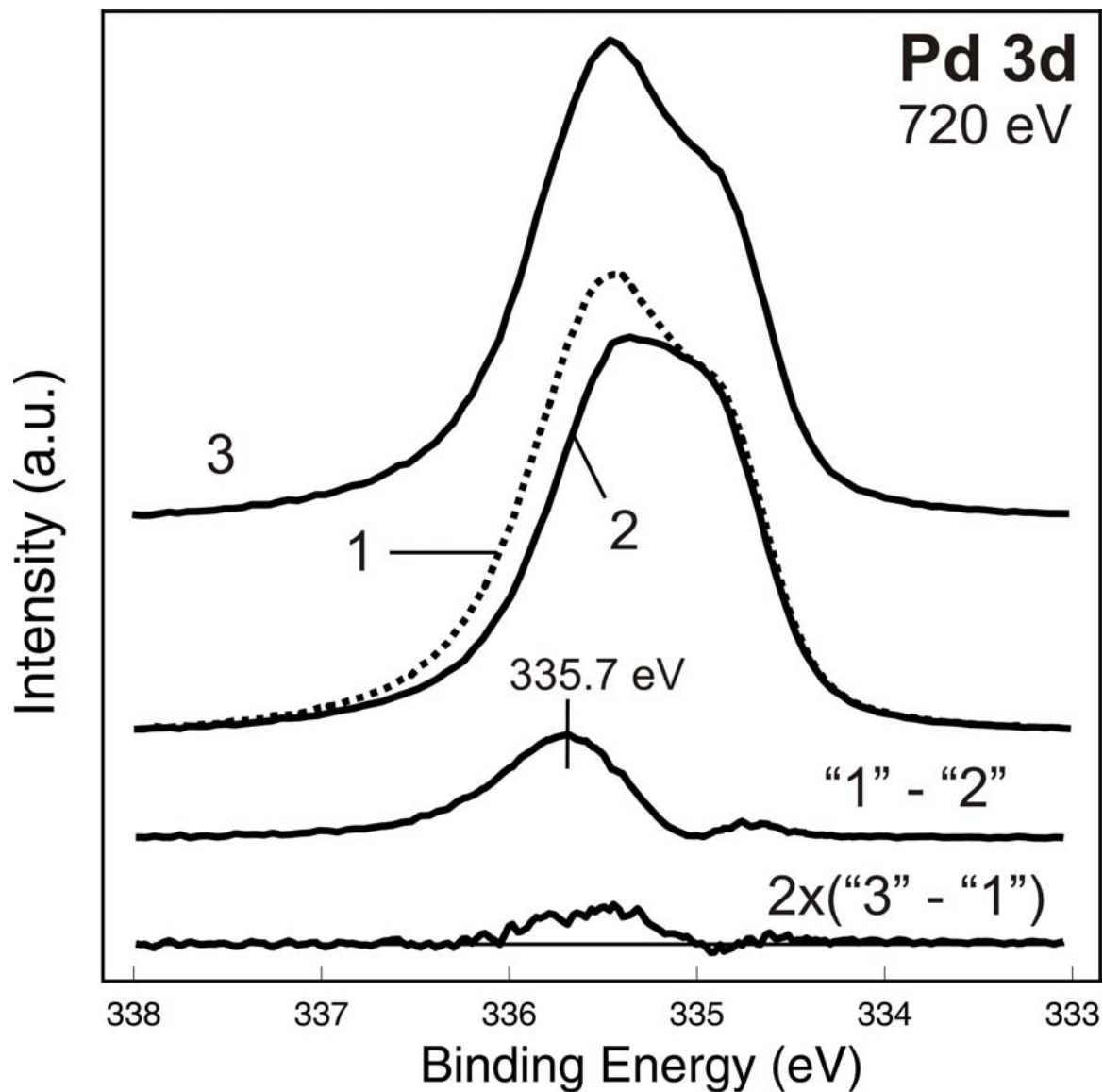

# In-situ XPS: Pd 3d (Switching off experiments)

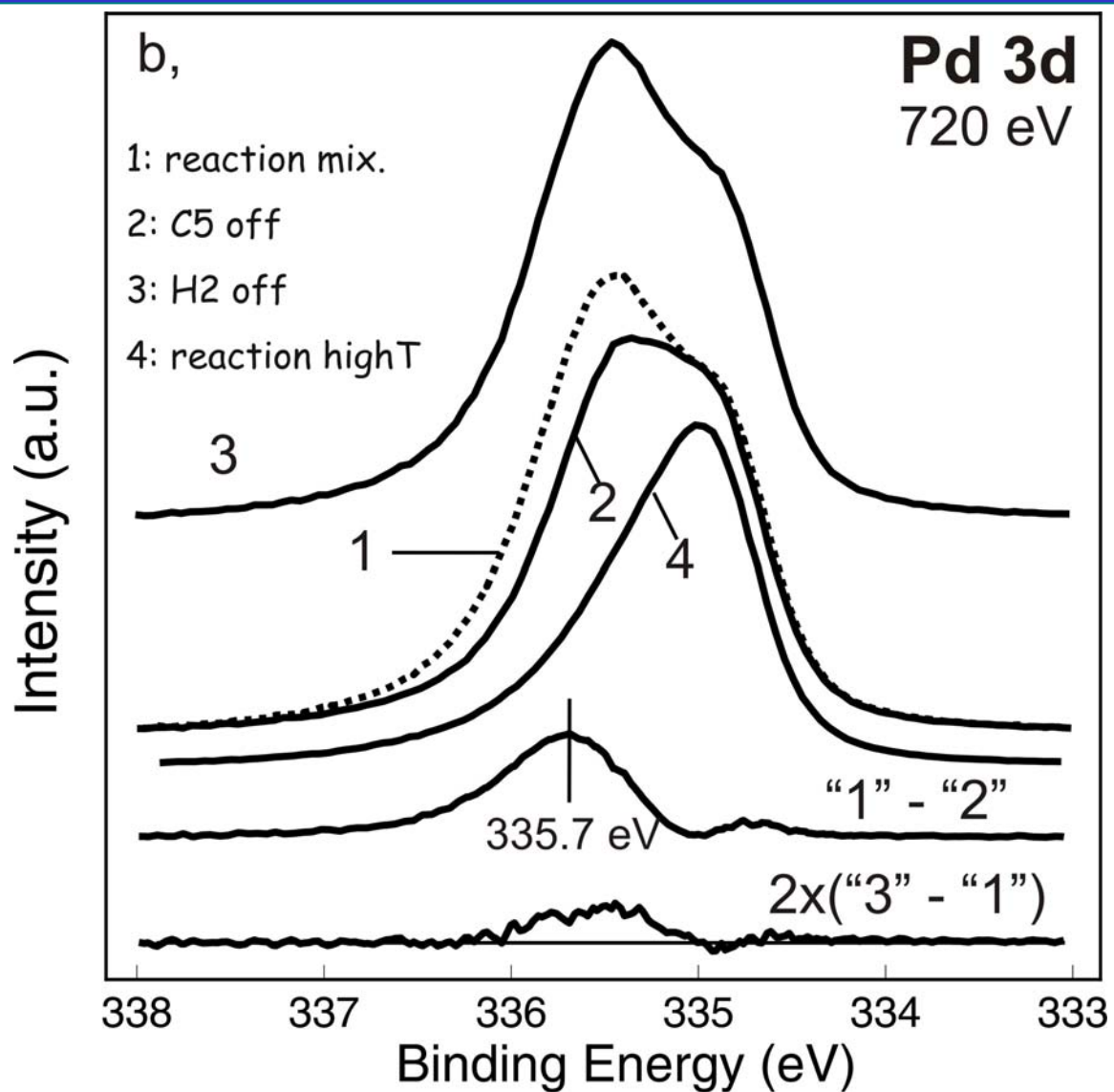

- 1: reaction mix.
- 2: C5 off
- 3: H2 off
- 4: reaction; high T

# In-situ XPS: Pd vs. C depth profiling

Model

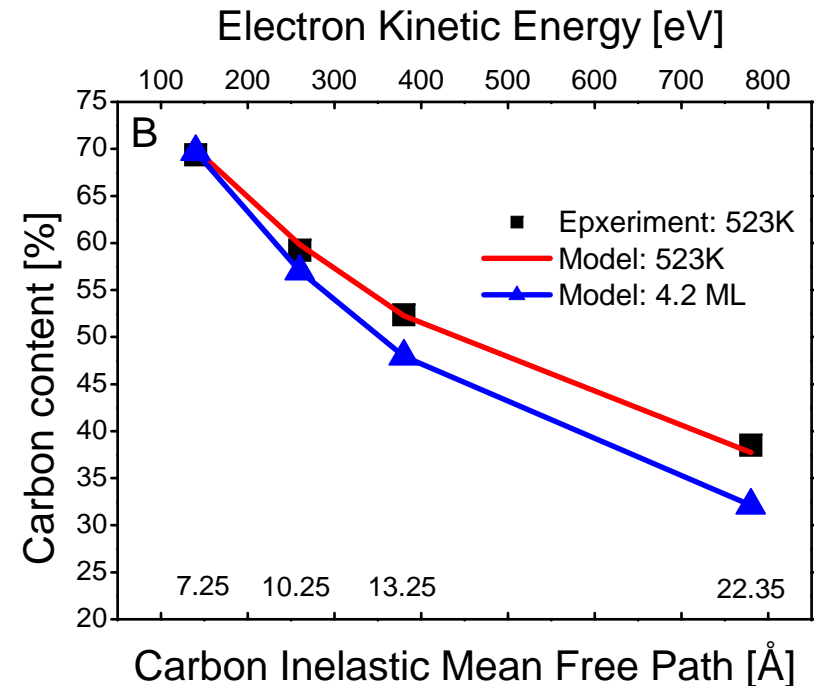
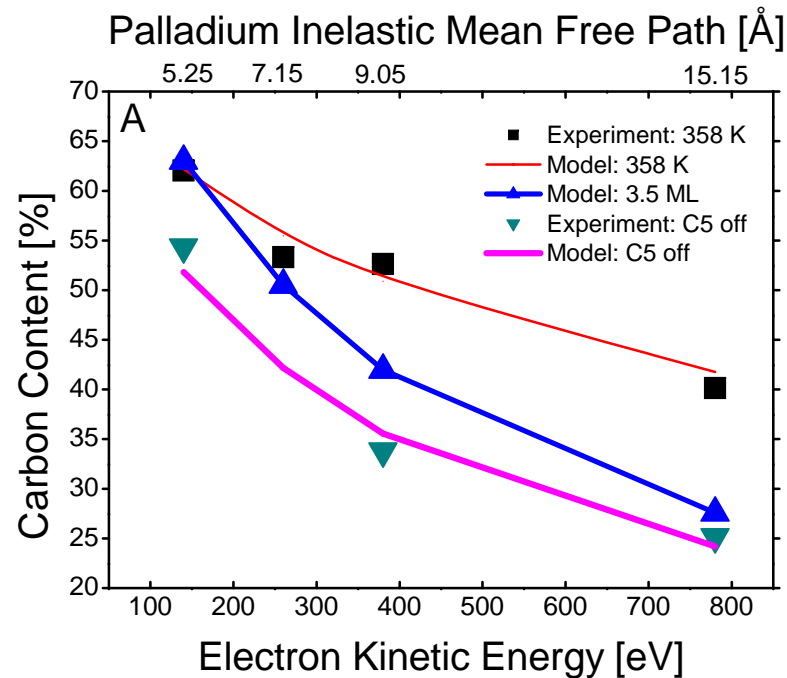
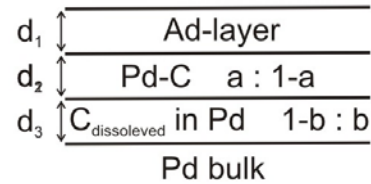



# Summary

---

1. Subsurface H: effective for alkene-to-alkane but also for alkyne-to-alkane transformation
2. Surface H: could be selective (spillover)
3. Different reaction orders in the different selectivity regimes & Abrupt changes between regimes
4. C uptake is considerably more in the selective regime
5. Pd-C surface phase forms in the early stage of selective pentyne hydrogenation & there is significant amount of subsurface C below of it

# Model (during the reaction)

---

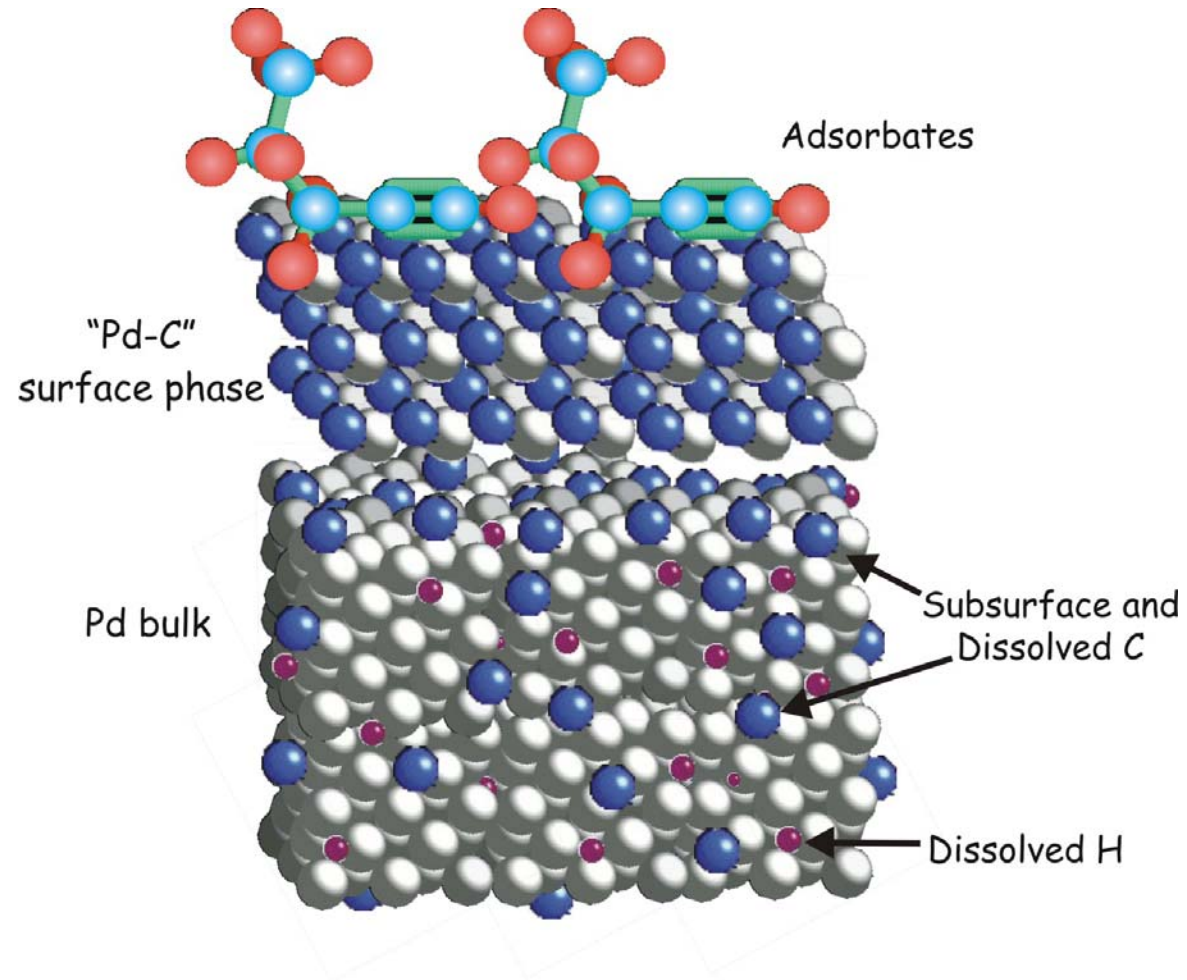

# Summary

---

1. Subsurface H: effective for alkene-to-alkane but also for alkyne-to-alkane transformation
2. Surface H: could be selective (spillover)
3. Different reaction orders in the different selectivity regimes & Abrupt changes between regimes
4. C uptake is considerably more in the selective regime
5. Pd-C surface phase forms during selective hydrogenation of pentyne & there is significant amount of subsurface C below of it
6. Dynamic behaviour of Pd-C and subsurface C

# Industry Collaboration of FHI (AC Department) @ BESSY

---

Sumitomo: Selective Propene Oxidation over  
Ag Catalysts

BASF: n-Butane Oxidation to Maleic Anhydride  
over VPO catalysts

Südchemie:  $\text{VO}_x/\text{TiO}_2$

DaimlerChrysler: surface composition of engine  
parts

Johnson Matthey: Athena



MAX-PLANCK-GESELLSCHAFT

# Outlook: In situ XPS / XAS The future at BESSY



ISISS:



## Innovative Station for In Situ Spectroscopy

A project of BESSY and the Dep. Inorganic Chemistry, Fritz-Haber-Institut

- ▶ Installation of a beamline exclusively used for in situ spectroscopy in the soft X-ray range
- ▶ Installation of infrastructure optimized for these kind of experiments on site (e.g. chemical lab, gas supply, gas analytics)
- ▶ Later, further implementation of other in situ spectroscopy techniques: multi wavelength Raman, UV-Vis, fluorescence yield ?!
- ▶ Start of user operation of the beamline: 2007



MAX-PLANCK-GESELLSCHAFT

# Outlook: In situ XPS / XAS The future at BESSY



ISISS:

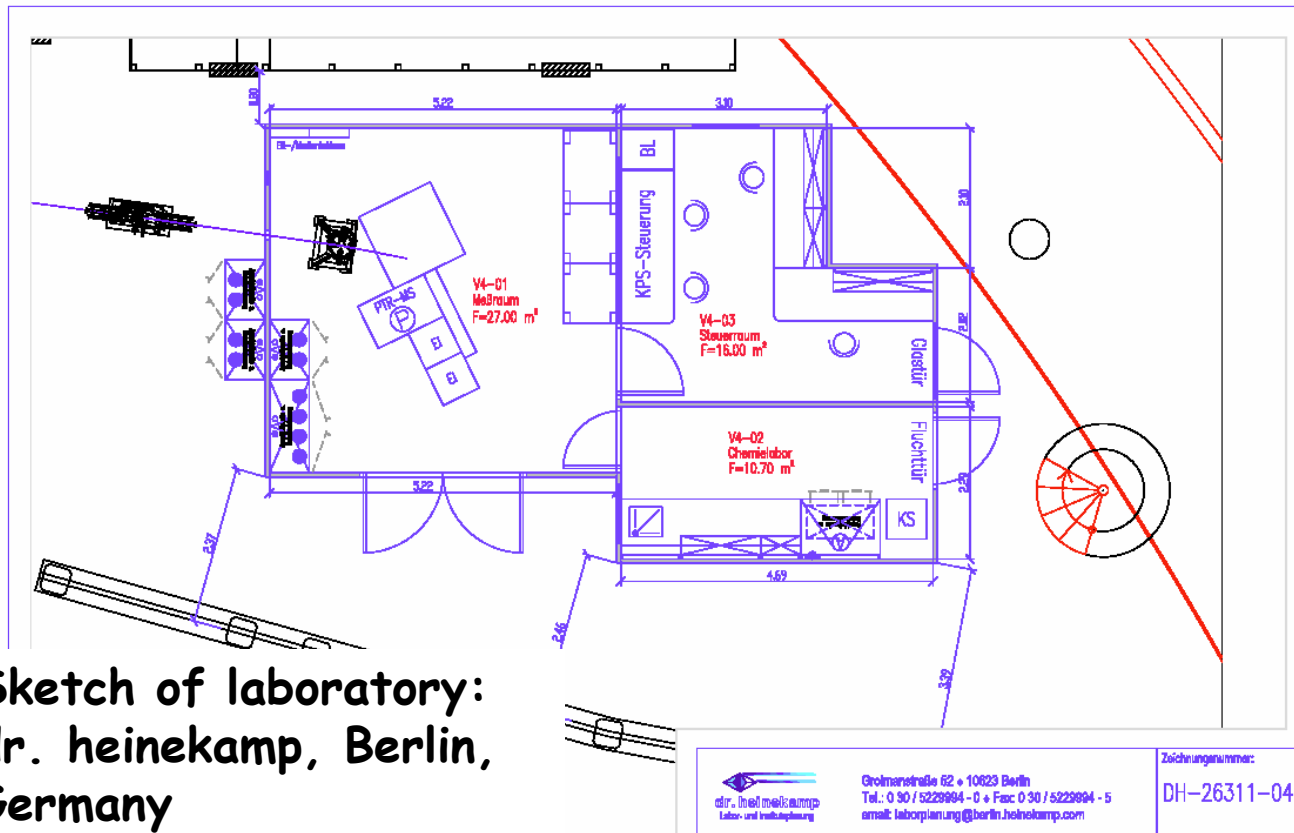

Sketch of laboratory:  
dr. heinekamp, Berlin,  
Germany



# Outlook: In situ XPS / XAS The future at BESSY

