

# Fast Switch / Power Combiner for High-Power Millimeter Waves: Concepts, Numerical Investigations and First Experiments

W. Kasperek<sup>1</sup>, M. Petelin<sup>2</sup>, V. Erckmann<sup>3</sup>, D. Shchegolkov<sup>2</sup>, A. Bruschi<sup>4</sup>, S. Cirant<sup>4</sup>,  
A. Litvak<sup>2</sup>, M. Thumm<sup>5</sup>, B. Plaum<sup>1</sup>, M. Grünert<sup>1</sup>, M. Malthaner<sup>1</sup>, ECRH groups at IPP  
Greifswald<sup>3</sup>, FZK Karlsruhe<sup>5</sup>, and IPF Stuttgart<sup>1</sup>.

<sup>1</sup>Institut für Plasmaforschung, Universität Stuttgart, 70569 Stuttgart, Germany

<sup>2</sup>Institute of Applied Physics, RAS, 603950 Nizhny Novgorod, Russia

<sup>3</sup>MPI für Plasmaphysik (IPP), EURATOM Association, 17491 Greifswald, Germany

<sup>4</sup>Istituto di Fisica del Plasma, EURATOM-ENEA-CNR, 20125 Milano, Italy

<sup>5</sup>Forschungszentrum Karlsruhe, Association EURATOM-FZK, IHM, 76021 Karlsruhe, Germany

## Corresponding author:

Dr. Walter Kasperek  
Institut für Plasmaforschung der Universität Stuttgart  
Pfaffenwaldring 31  
D-70569 Stuttgart  
Germany

Tel. ++49 711 685 2179

Fax ++49 711 685 3102

e-mail [walter.kasperek@ipf.uni-stuttgart.de](mailto:walter.kasperek@ipf.uni-stuttgart.de)

Pages (incl. text, refs, figures): 31

Tables: 0

Figures: 11

**Abstract:**

Narrow-band frequency diplexers in connection with small frequency-shift keying of gyrotrons can be used to switch the millimeter wave power between two output channels or to combine the power from different sources. This technique can e.g. be used for fast beam steering for synchronous stabilization of rotating neoclassical tearing modes (NTMs) in tokamaks. Beam steering can be performed by a multi-stage multiplexer, provided that phase-controlled sources are available. In the paper, various concepts for fast directional switches as well as their integration into transmission lines are discussed. Calculations and low-power measurements of prototypes are presented. Requirements and techniques for frequency control of the gyrotrons are discussed, and the results of preliminary frequency modulation experiments are shown. Future prospects for the application of diplexers in large ECRH systems are discussed. A resonant diplexer experiment in the beam duct of the high-power ECRH system for W7-X is presently being prepared.

**keywords:****Electron cyclotron heating, high-power switch, diplexer**

## I. INTRODUCTION

Electron Cyclotron Resonance Heating (ECRH) and Current Drive (ECCD) using gyrotrons is a well-established method to heat and control large-scale magnetic fusion plasmas in tokamaks and stellarators. In particular, ECRH is foreseen as a 'day-one system' for W7-X and ITER, which are the next step representatives of the stellarator and tokamak approach to nuclear magnetic fusion. ECRH has a very narrow power deposition in the plasma, which qualifies this method for localized heating and current drive. Besides the general feature of perfect absorption in hot plasmas and easy coupling by launching gaussian free-space wave beams towards the position, where the absorption is required, one of the most attractive features for tokamaks is the control of MHD instabilities and consequent improvement of the plasma parameters. As these instabilities are well localized around resonant magnetic surfaces, narrow and well-focused ECRH-wave beams have to be directed with high accuracy to the resonant layer <sup>1</sup>. Especially for the case where the width of the power deposition profile exceeds the width of the island, ECCD in the O-point of the island only gives highest efficiency for NTM stabilization. Modulation of the launched EC power synchronous with the rotating islands is required in this case.

Up to now, synchronous current drive is performed by power modulation of the gyrotron <sup>1</sup>, with the disadvantages that (i) half of the installed power is wasted, (ii) the collector of the gyrotrons can be thermally overloaded, and (iii) fast switching of MW powers can result in severe electromagnetic interference.

An alternative for power modulation could be switching of the millimeter waves between two launchers directing the beam to poloidal or toroidal planes, which are about 180°

apart from each other with respect to the phase of the NTM (see Fig. 1). Here, the power is switched synchronously with the island rotation by a fast directional switch (FADIS), while the source operates CW. This device is based on a small frequency-shift keying of the gyrotron ( $\Delta f_s \ll f_{ce}$ ), and a narrow-band frequency diplexer, which directs an input beam to one of the two output channels <sup>2</sup>. Note that for the tiny frequency shifts  $f_1 - f_2 = \Delta f_s$  of some tens of MHz needed for the switching, no remarkable change of the deposition radius in the plasma occurs. As any diplexer can be designed as four-port device, two gyrotrons can be fed into it. If both gyrotrons are shifted between frequencies  $f_1$  and  $f_2$ , but in opposite phase ("push-pull"), then the power of both gyrotrons is combined into one of the two outputs, and is switched between output 1 and 2 in the rhythm of the frequency-shift keying (see Fig. 2 and e.g. Ref. 3). Thus, there is no need to increase the number of launchers. Note that besides NTM stabilization, the FADIS can be used to share the installed EC power between different types of launchers or different applications (e.g. in ITER, midplane / upper launcher), whichever is given priority during a plasma discharge.

The diplexer can be realized as a quasi-optical interferometer with grating splitters, as a waveguide interferometer or resonator with 3-dB hybrids based on oversized rectangular corrugated waveguides, or, in the most compact form, as a quasi-optical cavity (ring resonator) with corrugated mirrors. The shift of the frequency in the gyrotron can be performed by modulation of the gun anode, or the beam acceleration voltage. In the paper, various concepts for fast directional switches are discussed. Calculations and low-power measurements of prototypes are presented, and the preparations and plans for a high-power test of a resonant diplexer in the beam duct of the ECRH system for W7-X are discussed. Requirements and techniques for frequency control of the gyrotrons are presented, and the results of preliminary

frequency modulation experiments are shown. Finally, future prospects for the application of diplexers in large ECRH systems are discussed.

## II. CHARACTERIZATION OF A WAVEGUIDE DIPLEXER

In this chapter, two waveguide diplexer designs are presented which are based on the Mach-Zehnder type of the two-beam interferometer<sup>3</sup>. Its basic elements are two 3-dB hybrids (power dividers) and a delay line in between. The devices discussed here employ corrugated rectangular waveguides which show image multiplication ("Talbot-effect") and thus can be used to design the 3-dB splitters<sup>4</sup>.

A sketch for a device, where the spatial Talbot effect is used for splitting is shown in Fig. 3. The power is fed as  $HE_{1,1}$  mode from a square or circular corrugated waveguide into the main rectangular diplexer waveguide with width  $a$  (and height  $b$ , which, however, is not relevant for the calculation). According to the propagation constants of the excited waveguide modes, the amplitude distribution at the entrance is split into two identical patterns after a length of  $a^2/(2\lambda)$ . At this position, a miter bend integrated into the waveguide directs one part into a folded delay line with length  $L_\phi$  made from corrugated square waveguide, and again couples this part back into the main waveguide. Depending on the relative phases of the two identical patterns, a recombination of the patterns occurs after a length of  $2a^2/\lambda$ .

If losses are neglected, the device has a transmission function like the ideal interferometer, i.e. the output power toggles between the two output waveguides according to

$$P_1(f) = P_0 \cdot \sin^2\left(\frac{\pi \cdot L_\phi f}{c}\right), \quad P_2(f) = P_0 \cdot \cos^2\left(\frac{\pi \cdot L_\phi f}{c}\right) \quad (1)$$

Therefore, for the application as a FADIS, the gyrotron has to be frequency shifted by

$$\Delta f_s = \frac{c}{2 \cdot L_\phi} \quad (2)$$

which can be adjusted by the length of the delay line. For a minimum contrast between the two channels of better than 1:9 (< 10% of the power in the wrong channel), the frequency stability of the source at  $f_1$  and  $f_2$ , respectively, must be  $f \pm 0.2 \cdot \Delta f_s$ .

Calculations using a mode-matching technique and optimization procedures have been performed showing that for highly oversized main waveguides optimum results are obtained, if  $HE_{1,1}$  modes from a waveguide with a width of  $a/2$  are coupled into the entrance and from the exit of the main waveguide. Detailed calculations (ohmic loss and loss in the miter bends of the delay line was neglected) have been performed for a diplexer at  $f = 140$  GHz,  $a = 60$  mm,  $b = 30$  mm, and  $L_\phi = 1680$  mm. Figure 4a shows the results. According to the mode analysis at the exit, the maximum output power in  $HE_{1,1}$  mode is more than 99%. An experimental device was built and investigated, showing a very good qualitative agreement with the calculations. An example is shown in Fig. 4b, where amplitude and phase distribution at the output are plotted for the frequency  $f_1 = 140.650$  GHz, where the maximum power is coupled to the upper exit. A similar picture with the power coupled to the lower exit is obtained for  $f_2 = 140.737$  GHz. Quantitatively, the measurements show a somewhat higher loss: at maximum, 96% of the input power is found at the upper or lower exit, and the mode analysis yields an  $HE_{1,1}$  mode purity of 80 %. This discrepancy can be explained by the loss of the standard miter bends in the delay line (about 1% per bend) and some imperfections in manufacturing of this prototype. Another 1% loss is expected from the input coupling<sup>5</sup>, as a

circular corrugated  $HE_{1,1}$  waveguide with diameter of 32 mm was used in contrast to the calculations.

Note that this diplexer can be upgraded to a combiner/diplexer by making the input section  $L = 2a^2/\lambda$  long. Then, the device gets two inputs at the upper and lower side of the waveguide, and allows simultaneous combining and switching of two sources into one output channel.

At present, a variant of the diplexer discussed above is in construction, which uses the angular splitting feature of rectangular waveguides <sup>6</sup>, as shown in Fig. 5. For this case, a 4-wall square corrugated waveguide with  $a = b = 60$  mm is used, and the delay-line is quasi-optical. The optics has imaging characteristics from the exit of the first 3-dB hybrid to the entrance of the second one. This means that – within the limitations due to the finite size of the optics – the losses of the higher-order beam modes excited from non-gaussian contents in the output pattern of the square waveguide should be very low. If appropriate for a compact and closed design, the delay line consisting of two pairs of mirrors M1 and M2 as well as the reference arm (mirror pairs M3 and M4) can be built as a combination of waveguide and optical line. For this case, the guiding of the waves in the plane perpendicular to the drawing is performed by corrugated walls which extend from the square waveguide all over the mirror arrangement; the (cylindrical) mirrors M1 – M4 are mounted between the corrugated plates and guide the waves in the plane parallel to the drawing plane.

Note that, for a given input beam or waveguide, the angular splitting concept results in much shorter 3-dB hybrids, as the transverse dimension of the square or rectangular waveguide can be similar to the beam diameter, in contrast to the spatial splitter, where a waveguide dimension of at least twice the input beam diameter is required.

These waveguide diplexers can be seen as examples for many possible variants of diplexers based on the imaging properties of corrugated rectangular waveguides. Some quasi-optical variants have been described in Ref. 7. Also, a resonator-type diplexer is under development<sup>8</sup>.

### III. DESIGN AND TEST OF A QUASI-OPTICAL FADIS

A compact design for a diplexer/FADIS can be obtained by an open quasi-optical arrangement of two reflecting diffraction gratings integrated into a quasi-optical ring resonator with a high Q-factor. A principle sketch is given in Fig. 6. An incident wave beam at frequency  $f_1$ , which is detuned from the resonance frequency  $f_2$  of the ring resonator, is reflected by the grating in a well-defined (specular) direction. If the incident RF beam is tuned to the resonant frequency, the ring resonator will be ‘loaded’ and the second grating emits the beam into another well-defined direction. The transmission to output 1 and 2 is given by<sup>9</sup>

$$T_1(f) \approx 1 - \frac{1}{1 + 4R_0/R_1^2 \cdot \sin^2(\pi Lf/c)}, \quad T_2(f) \approx \frac{(1 - A/R_1)^2}{1 + 4R_0/R_1^2 \cdot \sin^2(\pi Lf/c)} \quad (3)$$

where  $R_0$  and  $R_1$  are the efficiencies of the grating in 0<sup>th</sup> and -1<sup>st</sup> order,  $L$  is the round-trip length of the resonator and  $2A$  the loss (ohmic and diffractive) for one round-trip. With these parameters, the diplexer can be adapted to the FADIS application. The loaded quality factor of the resonator is approximately given by

$$Q = \frac{\pi f L \cdot \sqrt{R_0}}{c \cdot (R_1 + A)}, \quad (4)$$



and the required frequency shift of the gyrotron from the non-resonant frequency  $f_1$  to the resonance  $f_2$  is at least 1.5 times the FWHM of the resonance curve, i.e.

$$\Delta f_s \geq \frac{1.5f}{Q} . \quad (5)$$

For a reasonable contrast between the two channels of better than 1: 9, the frequency stability of the source at  $f_1$  can be rather low, as long as  $f_1$  is outside of the resonance; for  $f_2$ , a stability of  $f \pm 0.07 \cdot \Delta f_s$  is necessary.

This type of diplexer has been investigated in detail for high-power multi-channel transmission<sup>10</sup>. Low-power tests have been performed at a 34 GHz device with results in agreement with theory<sup>11</sup>, as shown in Fig. 7. At present, a prototype diplexer/combiner for 140 GHz/1 MW is built, and prepared for tests in the transmission system of the ECRH installation for W7-X at IPP Greifswald<sup>12</sup>. This diplexer consists of a ring resonator with  $L = 2.4$  m, matching mirrors for the incident beams from two gyrotrons and the two output beams, which will be coupled into calorimetric loads. The efficiency of the gratings is calculated as  $R_0 = 0.755$  and  $R_1 = 0.245$ , respectively. Preliminary low-power measurements on a mock-up have been performed, which agree well with the calculations. As an example, Fig. 8 shows a measurement of the transmission function in the resonant channel. From the fits of theoretical curves to the measurements, the following results were obtained. The grating depth was slightly lower, the corresponding efficiency in minus first order was  $R_1 = 0.22$ . The round-trip loss in the resonator was measured to be  $< 1.3 \%$  and is near to the theoretical value of about 1% determined by the ohmic loss, atmospheric attenuation, and beam truncation of the resonator mirrors. This results in an unloaded Q-factor of  $Q_0 \geq 536000$  and a loaded one of  $Q$

$\approx 14000$ . The beam patterns measured at the non-resonant and the resonant output show high content of the fundamental gaussian mode of 98.5 % and 99.8 %, respectively. The maximum contrast measured with lens horns matched to the output beams was about 1:50 in the resonant and 1:1000 in the non-resonant channel, as shown in Fig. 8. However, due to non-perfect matching of the input beams to the resonator, spurious power in higher-order modes of about 19 % could be measured as minimum output in the non-resonant channel. This will be improved by optimizing alignment and input parameters.

At 1 MW input power, the maximum electric field in the resonator corresponds to an energy-flux density of  $0.87 \text{ MW/cm}^2$ , which is below the  $1 \text{ MW/cm}^2$  threshold of atmospheric air breakdown. This allows the high-power test of the device in the W7-X ECRH system, which operates in normal atmosphere. As can be seen from Fig. 8, the free spectral range between two resonances is 125 MHz, therefore the typical frequency chirp of the W7-X gyrotrons during switch-on of about 300 MHz is by far sufficient to measure the transmission characteristics. For the FADIS application, a good contrast is reached for  $\Delta f_s > 30 \text{ MHz}$ .

#### **IV. OPTIONS FOR GYROTRON FREQUENCY CONTROL**

A fast frequency control of a free running single-mode gyrotron can be achieved only by changing an operation voltage: the change transforms electron beam parameters, including the reactive part of RF conductivity, and finally results in a frequency shift. In gyrotrons of the diode type, the total electron current goes through the HV modulator, and, consequently, the frequency control requires a high modulation power. Low-power frequency control is, however, possible for gyrotrons operating in the triode scheme, if the control voltage is

applied to a non-current-carrying electrode. Such power-saving operation is possible for gyrotrons with depressed collector also, if the control voltage is applied between the collector and the RF cavity. Even less power is needed in gyrotrons with the triode gun, where the control voltage is applied to the cathode-anode gap of minimal capacity.

The frequency control by means of the voltage variation is, obviously, accompanied with a reduction of the output RF power. To limit the reduction, it is necessary to limit the voltage swing and, accordingly, to enhance firstly the sensitivity of diplexer to small frequency variations, and secondly the precision of voltage control (see e.g. Ref. 13).

A very precise frequency control can be realized, in particular, by connecting the gyrotron to a frequency synthesizer by a phase locking loop<sup>14</sup>. The method was verified by an experiment with a 13 GHz triode-type gyrotron<sup>15</sup>: the spectral bandwidth was reduced by a factor of 20.

In the frame of the 140 GHz FADIS project, measurements of the frequency characteristics of the THALES gyrotrons for W7-X and on the GYCOM gyrotrons installed at FTU have been started. Although preliminary, some results are remarkable:

In the GYCOM tube, a clear modulation characteristic is found with a slope of about 10 MHz / kV. A modulation experiment with  $U_{\text{mod}} = 2$  kV and 500 Hz confirms this value. This modulation characteristic could result in a good contrast for the FADIS application without too much power loss in the second channel.

In the W7-X gyrotron, the frequency drift after thermalization of the cavity ( $> 1$  s) was less than 5 MHz / 160 sec. This high stability might allow to reduce the requirements concerning frequency control of the gyrotron; at least the matching of the diplexer

characteristics to the frequency of the gyrotron could be done by slowly moving one of the resonator mirrors. The output frequency showed spontaneous switching between two frequency levels (mostly 3.4 MHz apart, but larger separations have been observed for other gyrotron parameters), which also could be triggered by a modulation of the acceleration voltage by 1 kV. A possible explanation for these frequency levels is the modulation of the gain due to reflection of stray radiation in the gyrotron back into the cavity with the appropriate rotation direction.

Step-like variation of the frequency was often observed in gyrotrons with tiny reflections of the cavity mode from the output window ("long-line effect") and was also described theoretically <sup>16</sup>. Possibly, this effect could be used in the design of stable FADIS operation with reduced power loss.

## **V. INTEGRATION OF DIPLEXERS INTO TRANSMISSION LINES**

Especially for the application in larger ECRH systems, it is necessary to develop compact diplexers and integrate them into the transmission lines without interference with neighbouring lines. For optical transmission systems, an optical version of the FADIS is probably advantageous as well, and can be designed as an integral part of the whole system.

For transmission systems using circular corrugated waveguides, the matching to diplexers employing square waveguides or mirror set-ups can be done with appropriate optics, however, such arrangements may become bulky. Owing to the very high coupling coefficient between square and circular corrugated waveguides of up to 99.3% <sup>5</sup>, direct connection is

possible, as was done in the experiments described in chapter III. An elegant and very compact possibility is the synthesis of waveguide mode converters fed by a circular  $HE_{11}$  mode, which produce a field pattern which perfectly matches the input field of the diplexer<sup>17</sup>. This type of coupling would allow very compact matching e.g. to the resonant diplexer. An example for the design of a diplexer/combiner with two inputs and outputs by corrugated circular waveguides is sketched in Fig. 9. If the resonator mirrors are integrated into the walls of the vacuum chamber needed for evacuated transmission lines, a very compact FADIS design is obtained.

Depending on the EC application, the millimeter wave radiation can have different polarization, especially it may be elliptically polarized. It is therefore convenient to design the diplexers for arbitrary polarization. Designs using square or rectangular corrugated waveguide are not sensitive to polarization, provided that the correct corrugation depth is used<sup>18,19</sup>. Also, quasi-optical diplexers can be designed to work for arbitrary polarization, as gratings used as beam splitters can be tailored to have identical efficiency in TE and TM polarization (perpendicular and parallel to the grooves, respectively). The phase shift between polarization components can be compensated by proper orientation of the gratings in the resonator.

It should be noted, however, that in general, the two outputs of the FADIS need different polarization, as either the antennas or the applications corresponding to the outputs are different. Therefore, in general, the fast switch has to be installed in the transmission system between the sources and the elements for polarization control. Thus, designs for linear polarization can be used as well.

## VI. POSSIBLE UPGRADES

After demonstration of the wave beam switching by the simplest diplexers, more complicated schemes might be studied. For example, diplexers can be composed into a multiplexer-scanner (Fig. 10) capable to combine output powers of  $2N$  gyrotrons and, depending on their frequency shifts, forward the total power into one of two output channels. In Fig. 10 any rectangular box denotes a gyrotron and any circle denotes a diplexer. At one set of gyrotron frequencies each couple of gyrotrons feeds a common narrow-band diplexer  $d_k$  that transmits the combined power to one of diplexers  $D_k$  (situated in the upper line in Fig. 10). The frequency band of the diplexer  $D_k$  includes frequencies  $f_{k,1}$  and  $f_{k,2}$ , but does not include frequencies  $f_{k+1,1}$  and  $f_{k+1,2}$ . Under these conditions, the chain of diplexers  $D_k$  transmits powers of all gyrotrons to the common (upper) output. If frequencies in any couple of gyrotrons are interchanged  $f_{k,1} \Leftrightarrow f_{k,2}$ , all powers are combined by the lower line of diplexers  $\check{D}_k$ , and the total power is forwarded to the lower output in Fig. 10.

Still more flexible and simple schemes for wave beam combining and scanning might be realized, if based on gyrotrons with a phase control: gyroklystron amplifiers or injection locked auto-oscillators. To provide sufficiently high powers, such gyrotrons should operate at high-order modes. Presently, devices of this type deliver multi-megawatt powers in microsecond pulses at relatively low frequencies<sup>20</sup>, but output powers of future phase-locked millimeter-wave gyrotrons can reach the level of present free-running ones.

Combining and switching of mutually phased waves of high power could be provided by quasi-optical structures based on diffraction gratings or Talbot type oversized waveguide sections<sup>10, 21</sup>. As the simplest example (Fig. 11), let either one of two groups of gyrotrons be locked to a separate master oscillator (of phase  $\varphi_i$ ). In each subsystem, gyrotron outputs can

be combined into one sub-beam, and each sub-beam can be introduced into a 3 dB hybrid. By changing the mutual phase  $\varphi_1 - \varphi_2$  between the low-power master oscillators, the wave beam combined by the 3 dB hybrid can be switched from one output channel to another. Generally, possible versions of similar phased arrays are numerous.

## VII. CONCLUSION

Various concepts for fast directional switching and combination of high-power microwave beams in ECRH systems for fusion application are presented. It is shown that they offer promising features for a more flexible use of the installed ECRH power in tokamaks and stellarators. Combining of outputs of sub-systems of gyrotrons into one transmission line is of general interest and has many attractive applications, and fast switching of the combined beam from one output channel to another seems attractive for adaptive suppression of NTM modes. The FADIS method might be combined with slow mechanical scanning of steering mirrors or discrete tuning of the gyrotron frequency by the cryomagnet field.

The development of diplexers is underway, various concepts are under investigation. High-power FADIS experiments are in preparation at the IPP Greifswald, and the application at the tokamak FTU in Frascati is in discussion.

## REFERENCES

1. H. Zohm, G. Gantenbein, G. Giruzzi, S. Günter, F. Leuterer, M. Maraschek, J.P. Meskat, A.G. Peeters, W. Suttrop, D. Wagner, M. Zabiego and ASDEX-Upgrade Team, ECRH Group, "Experiments on neoclassical tearing mode stabilization by ECCD in ASDEX Upgrade". Nucl. Fus. **39** (1999) 577 – 580.
2. M. Petelin and W. Kasparek, "Electrically controlled scanning of wave beam produced by gyrotron: Option for plasma fusion experiment". Proc. 6th Int. Vacuum Electronics Conference (IVEC 2005), Noordwijk, The Netherlands, 2005, p. 131.
3. J.C.G. Lesurf, "Millimeter wave optics, devices and systems". Adam Hilger, Bristol, 1990 ISBN 0-85274-129-4, p. 136
4. S.V. Kuzikov, "Wave beam multiplication phenomena to RF power distribution systems of high-energy linear accelerators". Int. J. Infrared Millimeter Waves **19** (1998), 1523–1539.
5. K. Ohkubo, S. Kubo, M. Sato, H. Idei, Y. Takita, and T. Kuroda, "Rectangular corrugated waveguide and parallel corrugated plates for an elliptical gaussian beam". Fusion Eng. Design **26** (1995), pp. 325 – 333.
6. K. Ohkubo, S. Kubo, T. Shimosuma, H. Idei, Y. Yoshimura, T. Notake and W. Kasparek, "Extension of steering angle in a square corrugated waveguide antenna". Fusion Eng. Design **65** (2003) 657 - 672.



7. F.M.A. Smits, "Power combiners for incoherent waves", Proc. of 8<sup>th</sup> Joint workshop on ECE and ECRH, Report IPP III/186, Vol. 2, 607 – 621, 1993
8. A. Bruschi, this volume.
9. M.V. Klein, T.E. Furtak, "Optik". Springer-Verlag Berlin 1988 ISBN 3-540-18911-4, p. 236
10. M.I. Petelin, G. Caryotakis, A.A. Tolkachev et al, "Quasi-Optical Components for MMW Fed Radars and Particle Accelerators", in High Energy Density Microwaves, edited by R.M. Phillips, 1998 AIP Conference Proc. **474**, 304 – 315, 1998
11. Yu.I. Koshurinov, V.G. Pavelyev, M.I. Petelin, I.V. Turchin, and D.Yu. Shchegol'kov. "Diplexer based on open cavity with corrugated mirrors". Tech. Phys. Lett. **31** (2005) 709 - 711.
12. V. Erckmann et al., "EC-heating for W7-X: physics and technology". This volume.
13. P. Brand and G.A. Müller, "Circuit design and simulation of a HV-supply controlling the power of 140 GHz 1 MW gyrotrons for ECRH on W7-X". Fusion Eng. Design **66-68** (2003), 573 – 577.
14. A. Fernandez, M. Glyavin et al., "Some opportunities to control and stabilize frequency of gyrotron", Proc. 4th IVEC, Seoul, 2003, p. 172.

15. G. Golubyatnikov, A. Luchinin et al., "Experiment on phase locking triode-gun gyrotron to frequency synthesizer" (submitted to JETP Letters).
16. T.M. Antonsen, S.Y. Cai, G.S. Nusinovich, "Effect of window reflection on gyrotron operation". *Phys. Fluids* **B 4** (1992), 4131 – 4139.
17. D. I. Sobolev, A. V. Chirkov, G. G. Denisov, D. A. Lukovnikov, and V. I. Malygin: "Minimization of diffraction losses in big gaps of multi-mode waveguides". *Int. J. Infrared and Millimeter Waves*, **26** (2005), 953-965.
18. G.G. Denisov, S.V. Kuzikov, and N. Kobayashi, "RF analysis of ITER remote steering antenna for electron-cyclotron plasma heating". *Int. J. Infrared and Millimeter Waves*, **22** (2001), 1735-1760.
19. W. Kasperek, G. Gantenbein, B. Plaum, R. Wacker, A.V. Chirkov, G.G. Denisov, S.V. Kuzikov, K. Ohkubo, F. Hollmann, D. Wagner, "Performance of a remote steering antenna for ECRH/ECCD applications in ITER using four-wall corrugated square waveguide". *Nucl. Fusion* **43** (2003), 1505 - 1512.
20. E. Ilyakov, A. Krasnykh, I. Kulagin, S. Kuzikov, V. Lygin, M. Moiseev, M. Petelin, N. Zaitsev, "Ka-band 10 MW gyro-devices: an experiment and a project". 5<sup>th</sup> Int. Vacuum Electronic Conference (IVEC-2004), Monterey, CA, 2004, pp.61-62.
21. M. Petelin, "Quasi-optics in High-Power Millimeter-Wave Systems". 6<sup>th</sup> Workshop on High Energy Density and High Power RF, WV, USA, AIP 691, 2003, pp. 251-262.

## FIGURE CAPTIONS

**FIG. 1:** Principle for NTM stabilization using a fast directional switch: Synchronously with the rotation of the island, the ECCD beam is switched between two launchers which are about  $180^\circ$  apart from each other with respect to the mode phase.

**FIG. 2:** Sketch of a diplexer-combiner: For gyrotron A at frequency  $f_2$  and gyrotron B at frequency  $f_1$ , the power of both gyrotrons is combined at output 1. If the frequencies are exchanged, both gyrotrons exit at output 2.

**FIG. 3:** Principle for NTM stabilization using a fast directional switch: Synchronously with the rotation of the island, the ECCD beam is switched between two launchers which are about  $180^\circ$  apart from each other with respect to the mode phase.

**FIG. 4:** a) Calculated amplitude distributions for the waveguide diplexer for a frequency of 140.65 GHz, 140.693 GHz, 140.735, and 140.778 GHz (from top to bottom), which corresponds to a phase shift in the delay line (marked as black tick in the plots) of  $90^\circ$ ,  $180^\circ$ ,  $270^\circ$  and  $360^\circ$ , respectively. b) Measured amplitude and phase distribution at the exit for 140.65 GHz. Dynamic range shown is 30 dB with 3dB/colour step and  $20^\circ$ /step, respectively.

**FIG. 5:** Design of a diplexer-combiner based on angular splitting in square corrugated waveguide.

**FIG. 6:** Principle of the compact quasi-optical diplexer employing a ring resonator with gratings as input and output couplers.

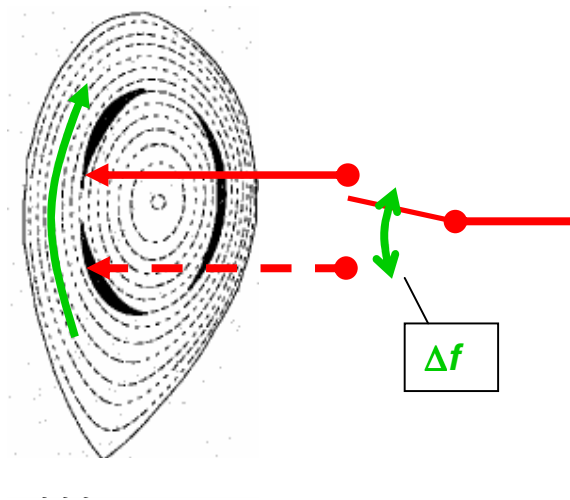
**FIG. 7:** Left: Photograph of a resonant diplexer for 34 GHz showing the input and output waveguides with the coupling mirrors for input and output 2 as well as the 4-mirror ring resonator. Right: Experimental (solid) and theoretical (dashed) curves illustrating RF power distribution between output channels. Frequencies  $f_1$  and  $f_2$  could be used for the FADIS.

**FIG. 8:** Left: Transmission functions for output 1 and output 2 of the 140 GHz resonant diplexer, measured in the gaussian TEM<sub>00</sub> mode. Dots: measured points, red solid curve: fit to theory. Right: Patterns of the output beams at maximum for the non-resonant and the resonant output. The dynamic range shown is 39 dB with 3dB/colour step.

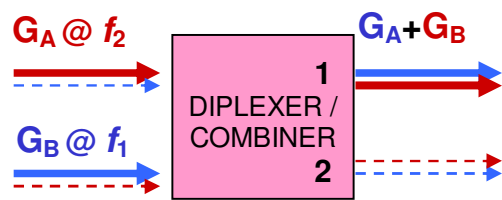
**FIG. 9:** Sketch of a resonant diplexer which is integrated into a pair of corrugated waveguides, replacing standard miter bends. The matching to the optical system is performed with waveguide mode converters.

**FIG. 10:** A multiplexer-scanner combining outputs of frequency-controlled gyrotrons and forwarding the combined wave beam into any of two output channels.

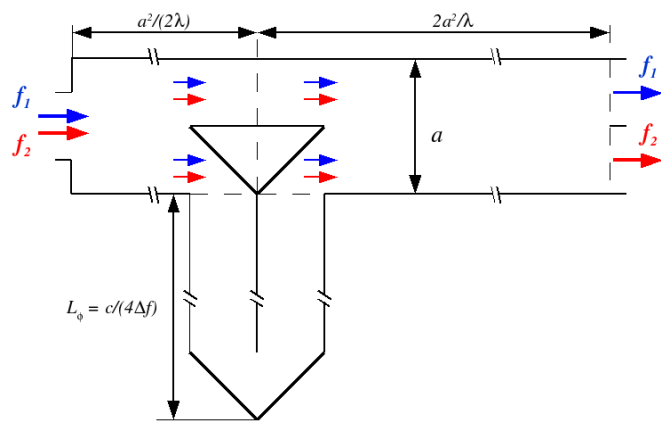
**FIG. 11:** Array of phase locked gyrotrons. The combined wave beam direction depends on the mutual phase of low-power-drive RF sources.



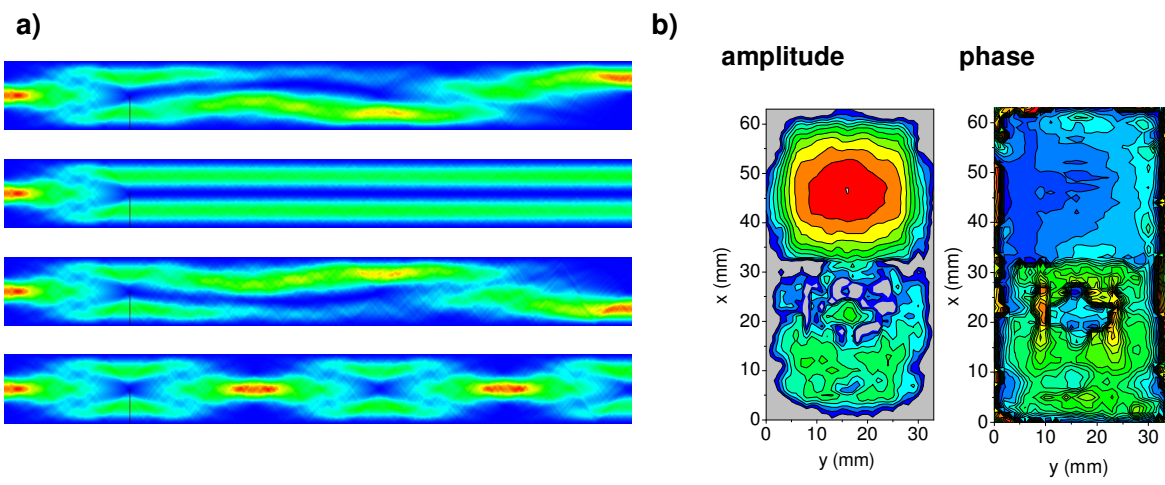
**FIGURE 1**



**FIGURE 2**

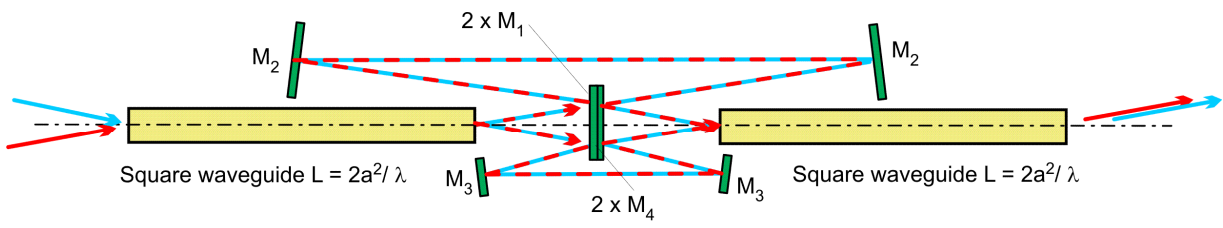


**FIGURE 3.**

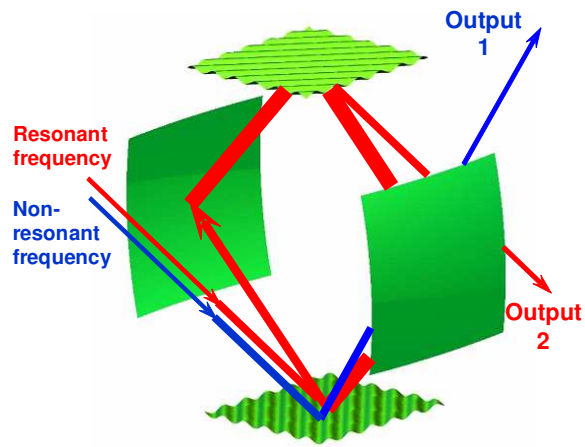


**FIGURE 4.**





**FIGURE 5:**



**FIGURE 6**

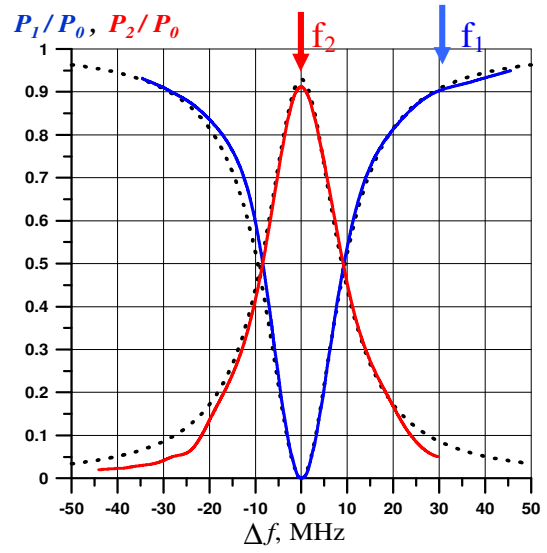
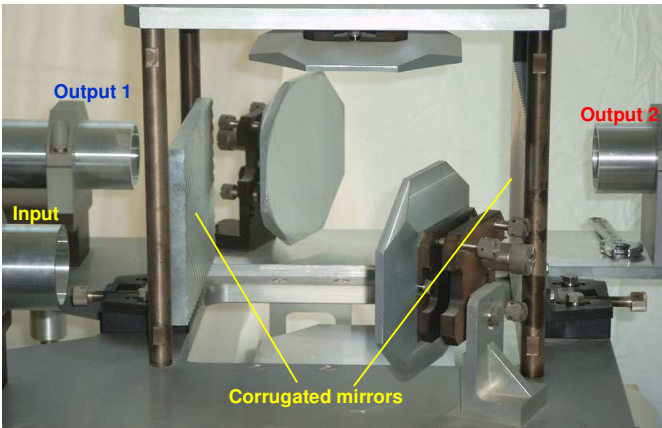


FIGURE 7

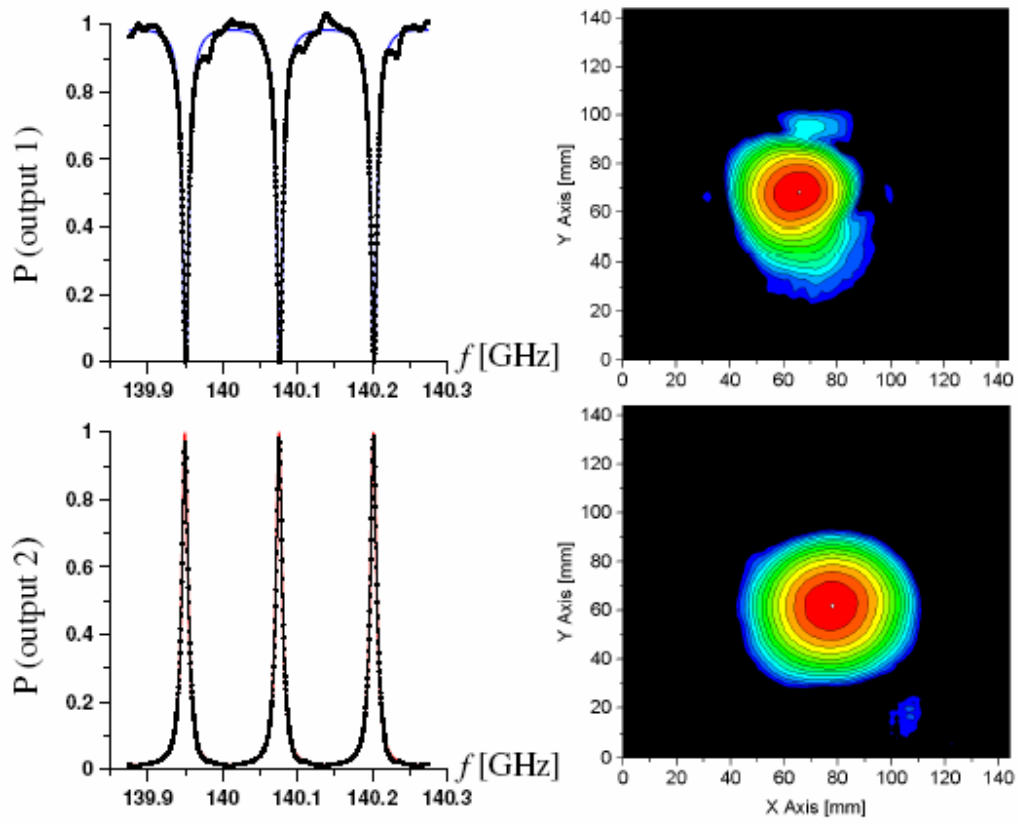
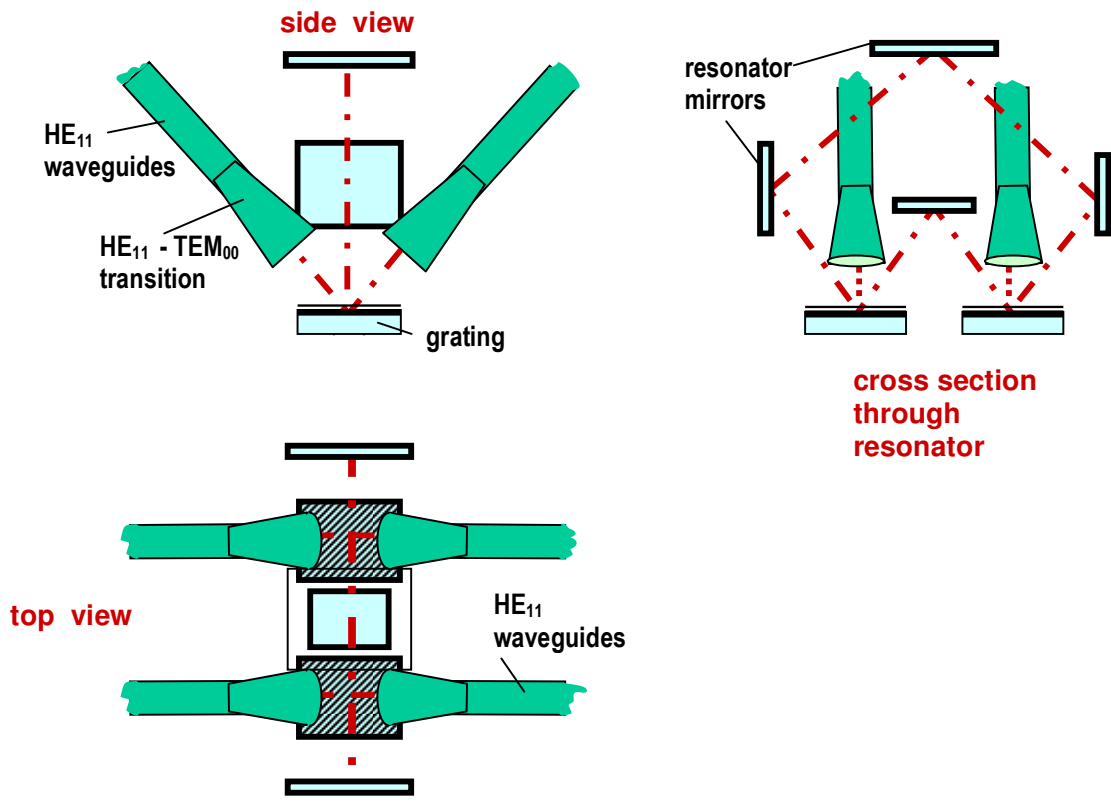
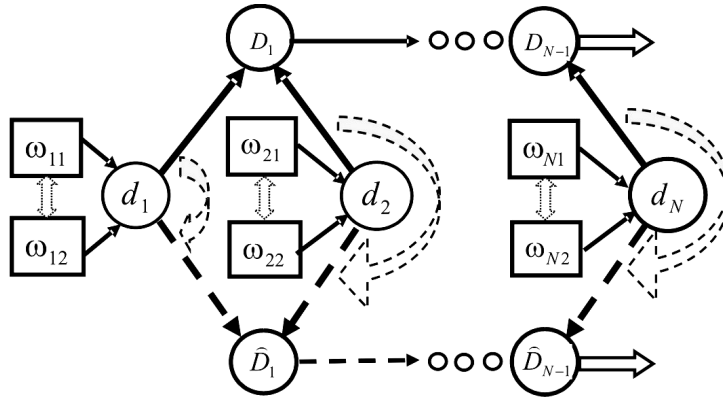


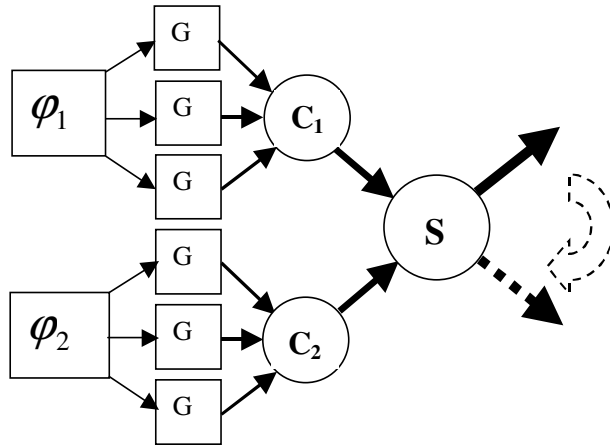
FIGURE 8



**FIGURE 9**



**FIGURE 10**



**FIGURE 11**