

Design Changes and Impact on the Production of the Non-Planar Coils for the W-7X Experiment

K. Riße, C. Sborchia, N. Valle, E. Theisen and the W7-X team

Abstract— The Max-Planck-Institut für Plasmaphysik is building the stellarator fusion experiment WENDELSTEIN 7-X (W7-X) at the branch institute in Greifswald, Germany. The 50 non-planar superconducting coils are currently manufactured by industry and use a specially developed NbTi cable-in-conduit conductor. The manufacture of the coils includes the conductor, winding of the conductor, vacuum pressure impregnation as well as the embedding of the winding pack into a cast steel casing, the final machining and the installation of the helium cooling system on the casing. Design changes became necessary during production in the connection areas of the casings due to more detailed design and structural analysis. In addition, the insulation and the welds in the termination area need to be improved. New quench detection cables were qualified. LINAC inspections allowed to check the presence of casting defects in the thick casings. Additionally high voltage tests in vacuum under Paschen-minimum conditions turned out to be a very sensitive inspection method to check the integrity of the electrical insulation.

Index Terms— High Voltage Tests, Non-planar Coils, Nuclear Fusion, Stellarator, Superconducting Coils, Wendelstein

I. INTRODUCTION

W7-X is based on the experience of the former stellarator experiment W7-AS. There are two main differences to the former experiments - the coils have a larger size and they are superconducting to allow steady state operation of the device. The coil system of W7-X consists of 50 non-planar coils and 20 planar coils [4].

The coil system is based on 5 different non-planar and 2 different planar coil types which are connected to a central support structure to form a half module (Fig. 1). Two half-modules are joined to a module and five equal modules will finally form the magnet system of W7-X. The whole coil system is protected by a cryostat which contains the plasma vessel, the ports and cooled radiation shields covering all parts

Manuscript received September 19, 2001.

Konrad Riße and the W7-X team is with the Max-Planck-Institut für Plasmaphysik, Euratom Association, Wendelsteinstraße 1, Germany 17489 Greifswald (phone: +49 3834 882720 fax: +49 3834 882709; e-mail: konrad.risse@ipp.mpg.de).

Dr. Carlo Sborchia is with the Max-Planck-Institut für Plasmaphysik, Euratom Association, Wendelsteinstraße 1, Germany 17489 Greifswald (phone: +49 3834 882753 fax: +49 3834 882709; e-mail: carlo.sborchia@ipp.mpg.de)

Nico Valle is with Ansaldo Superconduttori S.p.a, Corso Perrone 73 r, Italy 16152 Genua (phone: +39 010 6489238 fax: ++39 010 6489275; e-mail: nicolo.valle@as-g.it)

Eckard Theisen is with Babcock Noell Nuclear GmbH, Alfred -Nobel - Str. 20, Germany 97080 Würzburg (phone: +49 9319036036 fax: ++49 9319036010; e-mail: eckhard.theisen@bn-nuclear.de)

which are at ambient temperature. For winding of the coils a special cable-in-conduit conductor (CICC) is used. The coils are cooled by supercritical helium both through the voids of the cable-in-conduit conductor and through tubes which are attached to the coil casing. The non-planar coils have been contracted to a consortium formed by Babcock Noell Nuclear GmbH and Ansaldo Superconduttori S.p.A. The coil manufacturer ordered the superconductor at the consortium consisting of EAS GmbH (Germany) and OCSI (Italy). All coils are subject to an acceptance test at nominal operational conditions in the cryogenic test facility of CEA in Saclay (France).

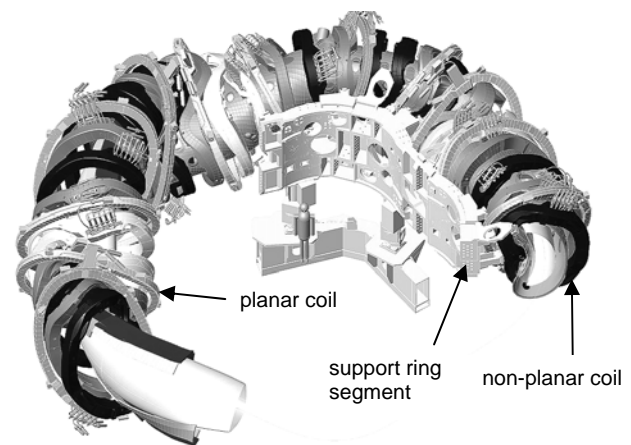

Fig. 1. Schematic view of the coil system of W7-X showing the non-planar and the planar coils, one segment of the support ring and plasma vessel segments. The outer vessel is not shown in this picture.

II. FABRICATION OF NON-PLANAR COILS

A. Superconductor Production

The W7-X coils are manufactured with a special cable-in-conduit conductor with a rope of 243 copper stabilized NbTi strands and an outer aluminium jacket with outer dimensions of 16 mm x 16 mm. The production of the W7-X superconductor is nearly finished. The cabling law of 3x3x3x3x3 leads to problems during rope cabling and the coextrusion [1]. Broken strands had to be accepted by IPP but will be used only for turns outside the high magnetic field, where the I_c margin is higher. Two broken strands at a distance of 50 m are allowed in one double layer length. Black oxidations on the Cu surface of the strands were detected, but the cause for it is not clear. Since the black oxides sticking firmly and showed no effect on the contact resistance inside the rope, they were finally accepted [2].

B. Winding Pack Production

The winding pack production was shared between ABB Augsburg (Germany) working as BNN subcontractor and Ansaldo Superconduttori (Italy) [1]. ABB has finished the production of 20 winding packages of the type 1 and 5 and Ansaldo has still to deliver the 7 remaining winding packs of 30 winding packages of type 2, 3 and 4. After winding the geometry, mass flow rate, high voltage insulation and He-tightness are checked on every double layer. Following a careful quality inspection on ABB side as well as by IPP, winding packs with shortages in the connection area were identified. A detailed analysis and qualification program was done. Since the locations of the short were easily accessible the repair action was successfully performed by the manufacturer. All winding packs met the stringent geometrical accuracy requirements of typically 2 mm.

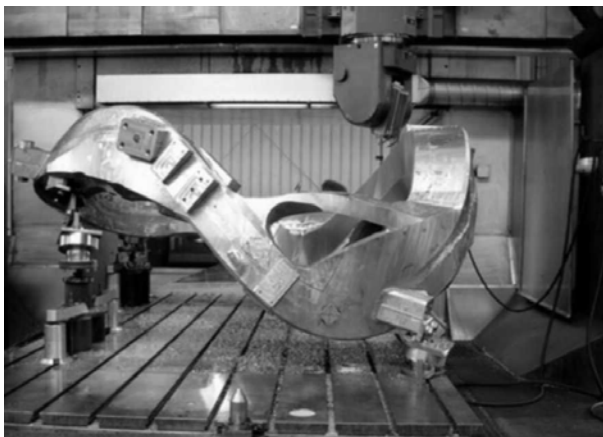

Fig. 2. Final milling process on a coil case, milling of the coil contour, surfaces and tap threads and fit holes

C. Production of coil casings

The stainless steel casings for the non-planar coils are cast as half-shells at Österby Gjuteri AB in Sweden. For each casing the material properties, the geometrical shape and casting defects are checked. The applied X-ray system to check for defects was limited to a material thickness of 70 mm. For areas with larger thickness a LINAC test was performed as described in chapter IV. The quality of the castings is very good in terms of castability and weldability, mechanical properties at cryogenic temperatures and geometrical tolerances. 44 of 50 casings were delivered to the coil assembly site and the remaining 6 casings are under machining and inspection.

D. Coil assembly and final acceptance tests

The coil assembly takes place at a Babcock Noell Nuclear site in Zeitz (Germany). The assembly is structured roughly in the following production steps: embedding of the winding packs into the casings with the final closure weld of the half shells; final milling process of the casings (Fig. 2); preparation of the cooling shield on the casing surface; instrumentation of the coil with temperature sensors and strain gauges. Up to now 7 non-planar coils were delivered to the final acceptance test facilities at CEA in France.

The requirements position accuracy of threads, fit holes and machined surfaces are very strong with typically 0.4 mm tolerance. This requirement is particular challenging since all interfaces are defined in three dimensions. The experience shows that the tight requirements could be fulfilled in most cases. Minor deviations were checked whether they could be accepted or whether a re-work had to be performed. Recently, some design changes have been implemented into the production resulting in the reinforcement of some welds and a change of the interfaces for the intercoil connections. BNN aims to reach a series production of the coils in the next month with a delivery of 2 coils per month.

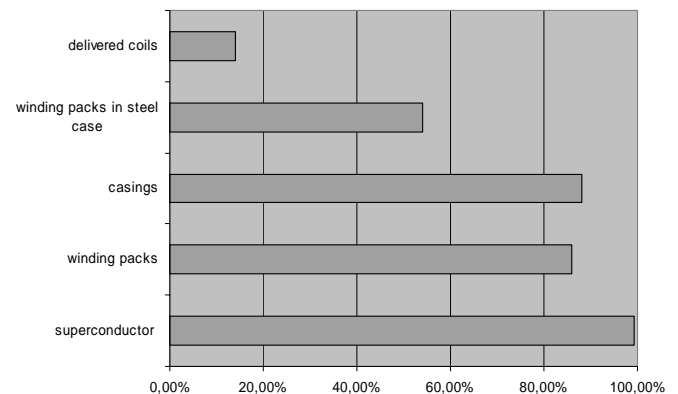

Fig. 3. Production status for the non-planar coil production in August 2005, describing the most important production steps and main component parts

The final acceptance test of each coil is performed at nominal working conditions in the cryogenic test facility of CEA in Saclay. Four non planar coils have been successfully tested with a very good performance and a slightly higher safety margin against a quench than expected. Fig. 3 gives a summary for the production status of the non-planar coils.

III. DESIGN CHANGES

A. Design changes on coil casing

A more detailed structural analysis of the magnet system of W7-X machine in 2003 resulted in higher loads and moments on the interfaces. An optimisation for the design of the coil support structure was found under the objective to distribute the electromagnetic loads among the support elements by minimizing the deformations of the winding packages when energized and by limiting the stresses within acceptable values. Consequently, the design of the supports had to be revised and modifications had to be introduced even in coils which have already been completed. [3].

1) *Connections to the central support ring:* The coils will be bolted to the central support ring by using the two central supports on each coil (Fig. 4). In order to be able to take forces in the order of 4MN in the most loaded connection, the numbers of threads in the coil supports was increased from typically 4 to 9 M30 Inconel bolts or, where the access to the bolts is limited, also to M76 or M90 bolts.

2) *Narrow support elements:* The narrow support elements

(NSE) are placed in those coil surface areas where two neighbouring non-planar coils approach each other very closely (Fig. 5). The NSE are realised by “contact elements” which must leave a gap of the order of 2 mm at 4 K at zero current. These come in contact during the ramp-up of the current and allow the coil casing to slide and tilt against each other. The NSE consists of a sliding pad made of Al-bronze alloy coated with MoS₂, which is fixed in a fit hole at the narrow support of the coil. The adjacent coil has a sliding surface with a roughness of Rz 0.6. When the pad goes into contact with the sliding surface a maximum compression force of about 1.5 MN at a magnetic field of 3 T can appear.

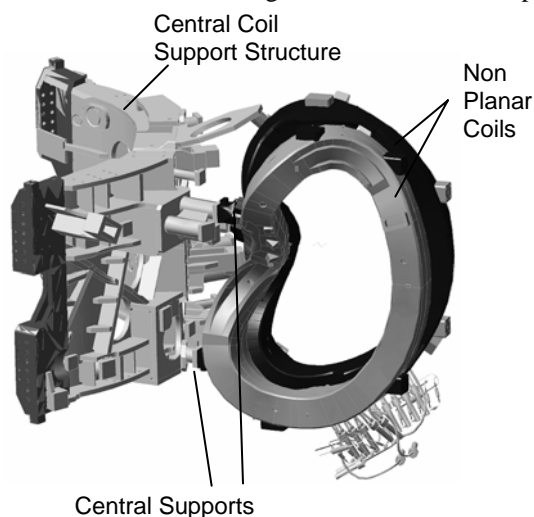

Fig. 4. Non-Planar Coils supported by the Central Coil Support Structure.

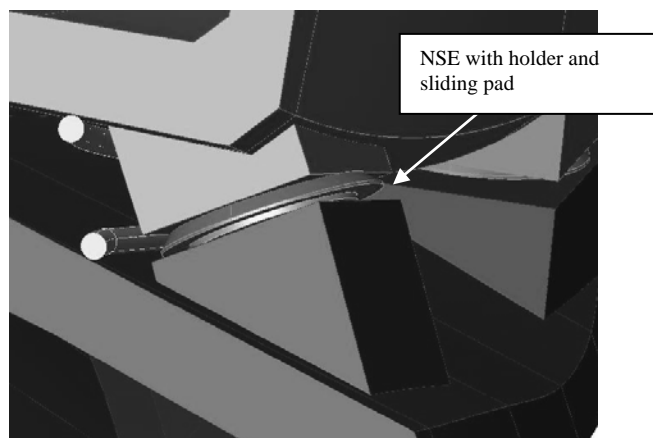

Fig. 5. Narrow area between two non planar coils with NSE in between, cooling pipes on the coil casing

Due to the possible movement of the contact elements and the lack of space in the narrow regions, the cooling pipes have to be mounted with a good precision onto the coil case. Partially the cooling pipes are placed in specially milled grooves. The coil surface in these areas has to be within a +1 mm tolerance.

4) *Planar supports*: The planar coils are fixed to the central support ring and supported against the non-planar coils by planar supports. The planar support elements are bolted onto

the non-planar coils and use the same design as of the sliding joints of the NSE. The initial gap between the pad surface and the stainless steel counter faces is 2 mm. The maximum compression load is about 0.5 MN.

B. Updated design of the Quench Detection wires

The first coil showed discharges under vacuum during the final acceptance test at CEA. It turned out that that these discharges were caused by undefined vacuum conditions inside the quench detection (QD) cable, in particular between the areas of the Kapton insulated wires and the surrounding Kapton layers. A new QD cable was developed and qualified in short time. The new cable consists of 6 pair-wise twisted Kapton insulated wires, with each wire having its own screen. The cable is mechanically stabilized by an outer screen. A series of qualification tests were passed successfully, as listed in Table I.

| test voltage | duration | conditions |
|--------------|-----------|---|
| DC 16kV | 10 min | in air as well in vacuum, room temperature (RT) |
| DC 10kV | 10 min | vacuum with Paschen conditions, RT |
| DC 17kv | 200 h | air, RT |
| AC 8kV/50Hz | 6 x 1 min | air, RT |
| DC 12kV | 10 min | vacuum and cryogenic temperature |

Due to the advanced state of production of the coils the new QD cable had to be connected to the old wires which were already installed inside the impregnated winding packs. A special connector was developed and tested. It consists of an outer glasfiber epoxy pipe, a special bush for the cable screens (2) and special plates where the individual screens for the wires (3) are collected. These screens are assembled in a special way to avoid remaining single filaments from the screen [Fig. 6]. The wires were soldered in the region of an insulating interpiece (4) and the complete body is filled with Stycast resin (1).

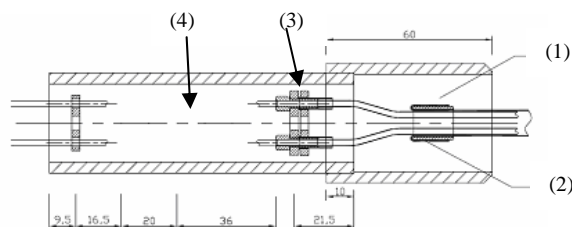

Fig. 6. Connector between the old and the new QD cable.

The test program of the QD connector included a 15 kV test under air, 10 thermo-cycles to LN₂ temperature and a 15kV high voltage under Paschen-minimum conditions. All tests were successfully passed.

IV. QUALITY CONTROL AND TESTS

Each production step starting from the superconductor production up to completion is accompanied by extensive tests. Before delivery to CEA Saclay a work acceptance test is

performed. The following additional tests were implemented in the production to ensure the specified quality of the components.

A. Linear accelerator tests on coil casings

Defects have been detected and repaired in the castings in the regions above 70 mm thickness due to the lack of hard X-ray equipment at the sub-contractor. Defects, such as shrinkages, pores and cracks appeared during the final machining in region with larger thickness, As a consequence BNN has launched in mid-2004 a campaign of inspections with high energy LINAC testing equipment (up to 8 MeV).

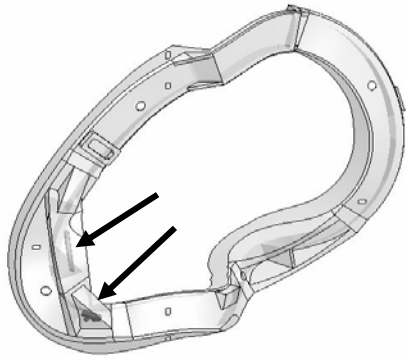

Fig. 7. Typical areas for casting defects on a half ring

This has included 21 finished coils and the remaining sets of half rings already delivered by Österby. Several defects have been found, especially in the regions of the reinforcing ribs and at the corners of the winding pack. Repair of some of the defects, mainly elongated shrinkages and cracks, has been carried out by local machining and filling by TIG welding. Typical defects are highlighted in Fig. 7 on a half ring.

B. High voltage tests under Paschen-minimum conditions

The ground insulation of the coils consists of 5 mm glass-epoxy composite impregnated under vacuum. In the termination area, where the interlayer joint and terminals are assembled, the manufacturers of the winding packs complete the insulation work with glass tapes and wet resin cured at lower (close to ambient) temperature. In this area the thickness has also been reduced to 2.5-3 mm.

The first high voltage test under vacuum performed at CEA Saclay revealed partial discharges at voltages significantly below the specified 9.1 kV, which were due to a weak behaviour of the QD cables, as discussed in Chapter III. Due to the concern about the quality and integrity of the insulation system in the terminal area and the re-work undertaken on finished coils to replace the QD cables, IPP has asked to perform additional HV tests in Paschen-minimum conditions (reduced pressures) during the work acceptance tests of coils. These tests are carried out in the vacuum tanks of BNN and Ansaldo, which are used for the final pressure/leak test. The high voltage tests will be carried out up to 9.1 kV at different pressure levels starting from 10^{-4} mbar until 100 mbar. During

the test a camera system observes the header region and allows to localize the foot point for flashes (Fig. 8). These tests turned out to be particularly useful and sensitive to check the insulation quality. The defects found in the hand wrapped insulation area of the headers required a reinforcement action on the coil insulation.



Fig. 8. Camera observation of a breakthrough during a high voltage test under Paschen conditions

C. Endoscopic investigation of welds

Recently, IPP performed endoscopic investigation of pipe welds in the He-circuits and the cooling system on the coil casings using an electronic endoscope type IPLEX SA from the Olympus Company. Different kinds of welding defects were found which lead to a complete rework of the He-circuits and the filters.

V. CONCLUSION

The manufacture of the non-planar coils of W7-X is well advanced. Design changes on the coil structures and necessary repair actions are implemented in the production. The superconductor production is almost complete and the winding pack production will end within the next month. The coil production will be completed in spring 2007.

ACKNOWLEDGMENT

The authors wish to thank the companies BNN and Ansaldo Superconduttori for the successful implementation of the design changes into the production process. The photos are partially by courtesy of BNN and Ansaldo.

REFERENCES

- [1] K. Risse, "Fabrication of the superconducting coils for Wendelstein 7-X" in Fusion Engineering and Design, volumes 66-68 (2003) SOFT-22 part A
- [2] R.K. Maix, "Design, Production and QA test results of the NbTi CIC conductors for the W7-X magnet system", EUCAS, Vienna Sept.2005
- [3] M. Gasparotto "The WENDELSTEIN 7-X Mechanical Structure Support Elements: Design and Tests", paper ID number 168, SOFT-23 in 2004
- [4] H.-S. Bosch and the W7-X Project Team, Wendelstein 7-X, Overview and Status of Construction; 21st IEEE /NPSS Symposium on Fusion Energy, Knoxville, September 2004