

FOURIER COEFFICIENTS OF MINIMAL AND NEXT-TO-MINIMAL AUTOMORPHIC REPRESENTATIONS OF SIMPLY-LACED GROUPS

DMITRY GOUREVITCH, HENRIK P. A. GUSTAFSSON, AXEL KLEINSCHMIDT,
DANIEL PERSSON, AND SIDDHARTHA SAHI

ABSTRACT. In this paper we analyze Fourier coefficients of automorphic forms on adelic split simply-laced reductive groups $G(\mathbb{A})$. Let π be a minimal or next-to-minimal automorphic representation of $G(\mathbb{A})$. We prove that any $\eta \in \pi$ is completely determined by its Whittaker coefficients with respect to (possibly degenerate) characters of the unipotent radical of a fixed Borel subgroup, analogously to the Piatetski-Shapiro–Shalika formula for cusp forms on GL_n . We also derive explicit formulas expressing the form, as well as all its maximal parabolic Fourier coefficient in terms of these Whittaker coefficients. A consequence of our results is the non-existence of cusp forms in the minimal and next-to-minimal automorphic spectrum. We provide detailed examples for G of type D_5 and E_8 with a view towards applications to scattering amplitudes in string theory.

Date: August 23, 2019.

2010 Mathematics Subject Classification. 11F30, 11F70, 22E55, 20G45.

Key words and phrases. automorphic function, small representations, minimal representation, next-to-minimal representation, Fourier coefficient, Whittaker coefficient, Whittaker support, nilpotent orbit, wave-front set, string theory.

CONTENTS

1.	Introduction and main results	2
1.1.	Introduction	2
1.2.	Fourier coefficients associated to Whittaker pairs	4
1.3.	Statement of Theorem A	5
1.4.	Statement of Theorem B	6
1.5.	Statement of Theorem C	8
1.6.	Statement of Theorem D	10
1.7.	Statements of Theorems E, F and G	11
1.8.	Illustrative examples	13
1.9.	Motivation from string theory	13
1.10.	Structure of the paper	15
1.11.	Acknowledgements	16
2.	Definitions and preliminaries	16
2.1.	Minimal and next-to-minimal representations	19
2.2.	Relating different Whittaker pairs	20
3.	Proof of Theorems A, B and C	21
3.1.	Proof of Theorem A	22
3.2.	Proof of Theorem B	23
3.3.	Proof of Theorem C	24
3.4.	Proof of Lemma 3.3.6	26
4.	Proof of Theorems D, E, F and G	27
4.1.	Proof of Theorem D	28
4.2.	Proof of Theorems E, F and G	29
4.3.	Proof of geometric propositions	31
5.	Detailed examples	34
5.1.	Examples for D_5	34
5.2.	An E_8 -example	38
	References	42

1. INTRODUCTION AND MAIN RESULTS

1.1. **Introduction.** Let \mathbb{K} be a number field and $\mathbb{A} = \mathbb{A}_{\mathbb{K}} = \prod' \mathbb{K}_{\nu}$, its ring of adèles. Let \mathbf{G} be a reductive group defined over \mathbb{K} , $\mathbf{G}(\mathbb{A})$ the group of adelic points of \mathbf{G} and G be a finite central extension of $\mathbf{G}(\mathbb{A})$. We assume that there exists a section $\mathbf{G}(\mathbb{K}) \rightarrow G$ of the covering $G \rightarrow \mathbf{G}(\mathbb{A})$, fix such a section and denote its image by Γ . This generality includes the covering groups defined in [BD01]. By [MW95, Appendix I], the covering $G \rightarrow \mathbf{G}(\mathbb{A})$ canonically splits over unipotent subgroups, and thus we will consider unipotent subgroups of $\mathbf{G}(\mathbb{A})$ as subgroups of G .

Let η be an automorphic form on G . Let U be a unipotent subgroup of G and χ_U be a unitary character of U that is trivial on $U \cap \Gamma$. We define the *Fourier coefficient* of η

associated with U and χ_U as

$$\mathcal{F}_{\chi_U}[\eta](g) := \int_{[U]} \eta(ug)\chi_U(u)^{-1}du, \quad (1.1)$$

where $[U] := (U \cap \Gamma) \backslash U$ denotes the compact quotient of U . Well-studied special cases of this definition arise when U is the unipotent N of a Borel subgroup and in that case the Fourier coefficients are called *Whittaker coefficients*, see (1.5) below. Another common case is when U is the unipotent of a (non-minimal) parabolic subgroup $P = LU \subset G$ and we shall refer to (1.1) in that case as a *parabolic Fourier coefficient*.

Generally, when U is non-abelian, the coefficient \mathcal{F}_{χ_U} only captures a part of the Fourier expansion of η . To reconstruct η from its coefficients one needs to consider a series of subgroups $U_{i_0} = \{1\} \subset U_{i_0-1} \subset \dots \subset U_1 = U$ with successive abelian quotients U_i/U_{i+1} . Two examples are the derived series of U , and the lower central series of U . Denote by \mathfrak{X}_i the set all non-trivial unitary characters of U_i that are trivial on U_{i+1} and on $U_i \cap \Gamma$. The complete Fourier expansion of η with respect to U takes the form

$$\eta = \mathcal{F}_0[\eta] + \sum_{\chi \in \mathfrak{X}_1} \mathcal{F}_{\chi_{U_1}}[\eta] + \sum_{\chi \in \mathfrak{X}_1} \mathcal{F}_{\chi_{U_1}}[\eta] + \dots + \sum_{\chi \in \mathfrak{X}_{i_0}} \mathcal{F}_{\chi_{U_{i_0}}}[\eta]. \quad (1.2)$$

The simplest case of a non-abelian U is one that admits a Heisenberg structure, *i.e.* $[U, U]$ is a one-dimensional group, and this will be an important tool for us when we analyse groups of type E_8 that do not admit any abelian unipotents U as radicals of parabolic subgroups. In this case, the lower central series coincide with the derived series. Namely, we take $i_0 = 3$ and U_2 to be $[U, U]$ and call the Fourier coefficients $\mathcal{F}_{\chi_{U_1}}[\eta]$ the *abelian* Fourier coefficients and those for U_2 the *non-abelian* Fourier coefficients.

For the most general Fourier coefficient (1.1) and automorphic form η not much is known about its reduction theory and explicit formulas. In particular, \mathcal{F}_{χ_U} is non-Eulerian and no analogues of the Casselman–Shalika [CS80] or Piatetski-Shapiro–Shalika formula [PS79, Sha74] are known. The problem becomes more tractable when restricting to coefficients given by Whittaker pairs [GGS17, GGS], a technique that we have used in the companion paper [GGK⁺] for studying the reduction theory.

In this paper we will analyze Fourier coefficients and expansions in the case of special classes of automorphic forms on split, simply-laced Lie groups. Specifically we consider automorphic forms η attached to so-called *minimal* or *next-to-minimal* automorphic representations π_{\min} and π_{ntm} of the adelic group G . This means that all Fourier coefficients attached to nilpotents outside of a union of Zariski closures of minimal or next-to-minimal nilpotent orbits vanish. We refer to §2.1 below for the precise definitions. We note that in type D there are two next-to-minimal complex orbits, while in types A and E the next-to-minimal orbit is unique. Minimal orbits are unique in all simple Lie algebras. A sufficient condition for π to be minimal or next-to-minimal is that one of its local components is minimal or next-to-minimal, see Lemma 2.0.7 below. For minimal representations, this condition is also shown to be necessary under some additional assumptions on G , see [GS05, KS15].

Even though we shall not rely on explicit automorphic realizations of minimal and next-to-minimal representations, it might be instructive to indicate how they can be obtained. Minimal representations have been studied extensively in the literature, in particular due

to their crucial role in establishing functoriality in the form of theta correspondences and [GRS97] discusses them as residues of degenerate principal series. Moreover, in a series of works [GRS11, GRS97, Gin06, Gin14], π_{\min} was used to construct global Eulerian integrals. Next-to-minimal representations have not been analyzed as extensively though in recent years this has started to change, partly due to their importance in understanding scattering amplitudes in string theory [GMV15, Pio10, FKP14, GKP16, FGKP18]; see §1.9 below for more details on this connection. Next-to-minimal representations exist for all next-to-minimal orbits, see *e.g.* §5, below and [FGKP18]. They can be obtained as different residues of degenerate principal series, see [GMV15, Pio10] for type E . In types A , E_6 , and for one of the orbits in type D there are one-parameter families of next-to-minimal representations.

In [GGS17, GGS] it was shown that there exist G -equivariant epimorphisms between different spaces of Fourier coefficients, thus determining their vanishing properties in terms of nilpotent orbits. In [GGK⁺] we determined exact relations (instead of only showing the existence of such) between different types of Fourier coefficients. In this paper we apply the techniques of [GGK⁺], and reduce maximal parabolic Fourier coefficients that are difficult to compute into more manageable class of coefficients such as the known Whittaker coefficients with respect to the unipotent radical of a Borel subgroup. Furthermore, we express minimal and next-to-minimal automorphic forms through their Whittaker coefficients.

In the next subsection we discuss the class of Fourier coefficients studied in [GGS17, GGS, GGK⁺]. This class includes parabolic coefficients, coefficients of lower central series (but not the derived series) for unipotent radicals of parabolics, and the coefficients considered in [GRS11, Gin06, Gin14, JLS16].

1.2. Fourier coefficients associated to Whittaker pairs. Assume throughout this paper that \mathbf{G} is a split simply-laced reductive group defined over \mathbb{K} . In order to explain our main results in more detail, we briefly introduce some terminology. Denote by \mathfrak{g} the Lie algebra of $\mathbf{G}(\mathbb{K})$. A *Whittaker pair* is an ordered pair $(S, \varphi) \in \mathfrak{g} \times \mathfrak{g}^*$, where S is a semi-simple element with eigenvalues of $\text{ad}(S)$ in \mathbb{Q} , and $\text{ad}^*(S)(\varphi) = -2\varphi$. This implies that φ is necessarily nilpotent and corresponds to a unique nilpotent element $f = f_\varphi \in \mathfrak{g}$ by the Killing form pairing. Each Whittaker pair (S, φ) defines a unipotent subgroup $N_{S, \varphi} \subset G$ given by (2.4) below and a unitary character χ_φ on $N_{S, \varphi}$ by $\chi_\varphi(n) = \chi(\varphi(\log n))$ for $n \in N_{S, \varphi}$.

Our results are applicable to a wide space of functions on G , that we denote by $C^\infty(\Gamma \backslash G)$ and call the space of automorphic functions. This space consists of functions f that are left Γ -invariant, finite under the right action of the preimage in G of $\prod_{\text{finite } \nu} \mathbf{G}(\mathcal{O}_\nu)$, and smooth when restricted to the preimage in G of $\prod_{\text{infinite } \nu} \mathbf{G}(\mathbb{K}_\nu)$. In other words, we remove the usual requirements of moderate growth and finiteness under the center \mathfrak{z} of the universal enveloping algebra. Such cases arise in applications in string theory [GV06, DGV15, FGKP18].

Following [MW87, GRS97, GRS11, GGS17] we attach to each Whittaker pair (S, φ) and automorphic function η on G the following Fourier coefficient

$$\mathcal{F}_{S, \varphi}[\eta](g) = \int_{[N_{S, \varphi}]} \eta(n g) \chi_\varphi(n)^{-1} dn. \quad (1.3)$$

We note that the integrals we consider in this paper are well-defined for automorphic functions as they are either compact integrals or represent Fourier expansions of periodic functions.

Remark 1.2.1. Note that the unipotent group $N_{S,\varphi}$ is not necessarily the unipotent radical of a parabolic subgroup of G . Consider, for example, the case of $G = E_8$ and let $P = LU \subset E_8$ be the Heisenberg parabolic such that the Levi is $L = E_7 \times \mathrm{GL}_1$ and the unipotent radical U is the 57-dimensional Heisenberg group with one-dimensional center $C = [U, U]$. Then the Fourier coefficient $\mathcal{F}_{S,\varphi}$ can include the “non-abelian” coefficient corresponding to $N_{S,\varphi} = C$ and χ_φ a non-trivial character on C . This case is relevant for applications to physics; see §1.9 below.

If a Whittaker pair (h, φ) corresponds to a Jacobson–Morozov \mathfrak{sl}_2 -triple (e, h, f_φ) we say that it is a *neutral* Whittaker pair, and call the corresponding coefficient a *neutral Fourier coefficient*. This is the class studied in [GRS11, Gin06, Gin14, JLS16] and referred to simply as a Fourier coefficient.

We denote by $\mathrm{WO}(\eta)$ the set of nilpotent orbits \mathcal{O} such that there exists a neutral pair (h, φ) such that $\mathcal{F}_{h,\varphi}[\eta] \neq 0$ and $\varphi \in \mathcal{O}$, see Definition 2.0.6 below. It was shown in [GGS17, Theorem C] that if $\mathcal{F}_{h,\varphi}[\eta] = 0$ then $\mathcal{F}_{S,\varphi}[\eta] = 0$ for any Whittaker pair (S, φ) , not necessarily neutral. We denote the set of maximal elements in $\mathrm{WO}(\eta)$ by $\mathrm{WS}(\eta)$ and call it the *Whittaker support* of η . We refer to automorphic functions η_{\min} whose Whittaker support consists of the minimal nilpotent orbit as minimal automorphic functions and write likewise η_{ntm} for next-to-minimal automorphic functions.

1.3. Statement of Theorem A. Choose a \mathbb{K} -split maximal torus $T \subset G$ and a set of positive roots. Let \mathfrak{h} be the Lie algebra of $T \cap \Gamma$. For a simple root α we denote by P_α the corresponding maximal parabolic subgroup, by L_α is standard Levi subgroup, and by U_α its unipotent radical. In other words, $\mathfrak{u}_\alpha := \mathrm{Lie} U_\alpha$ is spanned by the root spaces whose expression in terms of simple roots contains α with positive coefficient. Define $S_\alpha \in \mathfrak{h}$ by

$$\alpha(S_\alpha) = 2 \text{ and } \beta(S_\alpha) = 0 \text{ for all other simple roots } \beta. \quad (1.4)$$

It will follow from the definition of $N_{S,\varphi}$ that for any $\varphi \in \mathfrak{g}^*$ such that $\mathrm{ad}^*(S_\alpha)\varphi = -2\varphi$, we have that $N_{S_\alpha,\varphi} = U_\alpha$. This means that the Fourier coefficient $\mathcal{F}_{S_\alpha,\varphi}$ is the parabolic Fourier coefficient with respect to the unipotent subgroup U_α and the character χ_φ . Let $S_\Pi := \sum_{\alpha \in \Pi} S_\alpha$, where Π is the set of all simple roots. Then the associated unipotent subgroup is the radical N of the Borel subgroup defined by the choice of simple roots. For any $\varphi \in \mathfrak{g}^*$ with $\mathrm{ad}^*(S_\alpha)\varphi = -2\varphi$, and any automorphic function η define the Whittaker coefficient by

$$\mathcal{W}_\varphi[\eta] := \mathcal{F}_{S_\Pi,\varphi}[\eta]. \quad (1.5)$$

Theorem A. *Let η_{\min} be a minimal automorphic function on a simply-laced split group G and (S_α, φ) a Whittaker pair with S_α determined by a simple root α as above. Depending on the orbit of φ , we have the following statements for the corresponding Fourier coefficient.*

- (i) *The restriction of $\mathcal{F}_{S_\alpha,0}[\eta_{\min}]$ to the Levi subgroup L_α is a minimal or a trivial automorphic function.*

(ii) If φ is minimal, then there exists $\gamma_0 \in \Gamma \cap L_\alpha$ that conjugates φ to an element φ' of weight $-\alpha$ by $\text{Ad}^*(\gamma_0)\varphi = \varphi'$ and for any such γ_0 we have

$$\mathcal{F}_{S_\alpha, \varphi}[\eta_{\min}](g) = \mathcal{W}_{\varphi'}[\eta_{\min}](\gamma_0 g). \quad (1.6)$$

(iii) If φ is not minimal and not zero then $\mathcal{F}_{S_\alpha, \varphi}[\eta_{\min}] = 0$.

For part (i) we remark that $\mathcal{F}_{S_\alpha, \varphi}[\eta_{\min}]$ is the usual constant term in a maximal parabolic. For Eisenstein series it can be computed using the results of [MW95]. It can also be expressed through Whittaker coefficients using Theorem B below.

Remark 1.3.1. We note that the formula (1.6) is compatible with the expected equivariance of the Fourier coefficient $\mathcal{F}_{S_\alpha, \varphi}[\eta_{\min}](g)$, i.e. it satisfies

$$\mathcal{F}_{S_\alpha, \varphi}[\eta_{\min}](ug) = \chi_\varphi(u)\mathcal{F}_{S_\alpha, \varphi}[\eta_{\min}](g), \quad (1.7)$$

for all $u \in U$. For this to hold one requires that $\gamma_0^{-1}u\gamma_0 \in N$ for all $u \in U$ and

$$\chi_\varphi(u) = \chi_{\varphi'}(\gamma_0^{-1}u\gamma_0), \quad (1.8)$$

which indeed holds due to the fact that $\gamma_0 \in \Gamma \cap L_\alpha$.

Remark 1.3.2. The notation $\mathcal{W}_{S, \varphi}$ and \mathcal{W}_φ is used in [GGs17, GGS] to denote something quite different. It was chosen for the current paper since this is the notation in [FGKP18].

One can also obtain an expression for the minimal automorphic function itself. This is the subject of the next subsection.

1.4. Statement of Theorem B. For any root ε denote by $\mathfrak{g}_\varepsilon^* := \{\omega \in \mathfrak{g}^* \mid \text{ad}^*(h)\omega = \varepsilon(h)\omega \text{ for all } h \in \mathfrak{h}\}$ the corresponding subspace of \mathfrak{g}^* and by $\mathfrak{g}_\varepsilon^\times$ the set of non-zero elements of this subspace. Note that $\mathfrak{g}_\varepsilon^*$ is a one dimensional linear space over \mathbb{K} . We say that a simple root α is an abelian or a Heisenberg simple root in \mathfrak{g} if \mathfrak{u}_α is an abelian or Heisenberg Lie algebra, respectively, or, equivalently, if $[\mathfrak{u}_\alpha, \mathfrak{u}_\alpha]$ has dimension zero or one. If α is either abelian or Heisenberg we call it *quasi-abelian*. The classification of such roots reduces to simple components of \mathfrak{g} , where we have the following explicit answer in terms of Bourbaki numbering.

TABLE 1. Quasi-abelian roots

	A_n	D_n	E_6	E_7	E_8
abelian	all	$\alpha_1, \alpha_{n-1}, \alpha_n$	α_1, α_6	α_7	-
Heisenberg	-	α_2	α_2	α_1	α_8

To derive Table 1 we note that the abelian roots are those that appear with coefficient one in the highest root. The Heisenberg roots are determined in [GGK⁺, Lemma 5.1.2]. There are no such roots in type A_n , while in types D_n or E_n this is the unique root that connects to the affine node in the affine Dynkin diagram.

By [Bou75, §VIII.3] the abelian roots are precisely those that can be conjugated to the affine node by an automorphism of the affine Dynkin diagram.

Let $I = (\beta_1, \dots, \beta_n)$ be an enumeration of the simple roots of \mathfrak{g} in some order, and let \mathfrak{l}_i be the Levi subalgebra with simple roots $\{\beta_1, \dots, \beta_i\}$. We will say that I is *abelian* if each

β_i is abelian in \mathfrak{l}_i , and that I is *quasi-abelian* if each β_i is quasi-abelian in \mathfrak{l}_i . From the table we see that the Bourbaki enumeration is quasi-abelian if $\mathfrak{g} = E_8$ and abelian if \mathfrak{g} is simple (simply-laced) and different from E_8 . We also note that $\mathfrak{l}_i \subset \mathfrak{l}_j$ for $i < j$.

Let $I = (\beta_1, \dots, \beta_n)$ be any quasi-abelian enumeration of the simple roots of \mathfrak{g} . Given an automorphic function η on $\Gamma \backslash G$ we define functions $A_i[\eta]$, $B_i[\eta]$ and $C_i[\eta]$ on G as follows.

Let L_{i-1} be the Levi subgroup of G with Lie algebra \mathfrak{l}_{i-1} , and let Q_{i-1} be the parabolic subgroup of L_{i-1} with Lie algebra $(\mathfrak{l}_{i-1})_{\leq 0}^{\beta_i^\vee}$. In Lemma 3.2.1 below we show that Q_{i-1} is the stabilizer in L_{i-1} of the root space $\mathfrak{g}_{-\beta_i}^*$, as an element of the projective space of \mathfrak{l}_i^* . We let $\Gamma_{i-1} = (L_{i-1} \cap \Gamma) / (Q_{i-1} \cap \Gamma)$, and put for $i \in \{1, \dots, n\}$

$$A_i[\eta](g) := \sum_{\gamma \in \Gamma_{i-1}} \sum_{\varphi \in \mathfrak{g}_{-\beta_i}^\times} \mathcal{W}_\varphi[\eta](\gamma g), \quad (1.9)$$

where $\Gamma_0 = \{1\}$.

Remark 1.4.1. Note that although γ is a coset, the inner sum $\sum_{\varphi \in \mathfrak{g}_{-\beta_i}^\times} \mathcal{W}_\varphi[\eta](\gamma g)$ is independent of the choice of a representative for γ , since $Q_{i-1} \cap \Gamma$ stabilizes $\mathfrak{g}_{-\beta_i}^\times$. Thus $A_i[\eta]$ is well-defined. We will use similar summations over cosets in the future without further comment.

If β_i is a Heisenberg root of \mathfrak{l}_i , then we define

$$\mathcal{B}_{\beta_i} := \{\text{positive roots } \beta \text{ of } \mathfrak{l}_i : \langle \beta_i, \beta \rangle = 1\}, \quad \Omega_i := \text{Exp}\left(\bigoplus_{\beta \in \mathcal{B}_{\beta_i}} \mathfrak{g}_{-\beta}\right). \quad (1.10)$$

Note that Ω_i is a commutative subgroup of Γ . Denote by α_{\max}^i the highest root for the simple component of \mathfrak{l}_i containing β_i , and let s_{β_i} and $s_{\alpha_{\max}^i}$ denote the reflections with respect to the roots β_i and α_{\max}^i . Then $s_i := s_{\beta_i} s_{\alpha_{\max}^i} s_{\beta_i}$ is an involutive Weyl group element that switches β_i and α_{\max}^i . We fix a representative $\gamma_i \in \Gamma$ for s_i and define

$$B_i[\eta](g) := \sum_{\omega \in \Omega_i} \sum_{\varphi \in \mathfrak{g}_{-\beta_i}^\times} \mathcal{W}_\varphi[\eta](\omega \gamma_i g). \quad (1.11)$$

Finally, we define

$$C_i[\eta] := \begin{cases} A_i[\eta] & \text{if } \beta_i \text{ is abelian} \\ A_i[\eta] + B_i[\eta] & \text{if } \beta_i \text{ is Heisenberg.} \end{cases} \quad (1.12)$$

Theorem B. *Let η_{\min} be a minimal automorphic function on G . Then, for any choice of a quasi-abelian enumeration we have*

$$\eta_{\min} = \mathcal{W}_0[\eta_{\min}] + \sum_{i=1}^n C_i[\eta_{\min}]. \quad (1.13)$$

Let us now formulate analogs of Theorems A and B for next-to-minimal automorphic functions.

1.5. Statement of Theorem C. As before, let α be a simple root of \mathfrak{g} , and let (S_α, ψ) be a Whittaker pair such that $\psi \in \mathfrak{g}_{-\alpha}^\times$ and S_α defines the maximal parabolic subgroup corresponding to α . Let $I^{(\perp\alpha)} = (\beta_1, \dots, \beta_m)$ be a quasi-abelian enumeration of the simple roots orthogonal to α which is always possible to find, see Table 1. For any $1 \leq i \leq m$, we also define Γ_{i-1} and γ_i as above, and given an automorphic function η on $\Gamma \backslash G$ we set

$$A_i^\psi[\eta](g) = \sum_{\gamma \in \Gamma_{i-1}} \sum_{\varphi \in \mathfrak{g}_{-\beta_i}^\times} \mathcal{W}_{\psi+\varphi}[\eta](\gamma g). \quad (1.14)$$

For any $1 \leq i \leq m$ with β_i a Heisenberg root in the Levi subalgebra given by β_1, \dots, β_i , we furthermore set

$$B_i^\psi[\eta](g) = \sum_{\omega \in \Omega_i} \sum_{\varphi \in \mathfrak{g}_{\beta_i}^\times} \mathcal{W}_{\psi+\varphi}[\eta](\omega \gamma_i g). \quad (1.15)$$

Finally, we define

$$C_i^\psi[\eta] = \begin{cases} A_i^\psi[\eta] & \text{if } \beta_i \text{ is abelian} \\ A_i^\psi[\eta] + B_i^\psi[\eta] & \text{if } \beta_i \text{ is Heisenberg.} \end{cases} \quad (1.16)$$

Furthermore, let $\bar{\mathfrak{b}}$ be the Lie algebra of the negative Borel spanned by \mathfrak{h} and the root spaces of negative roots. For an element $\gamma \in \Gamma$, we define

$$\mathfrak{v}_\gamma := \mathfrak{g}_{>1}^{\gamma S_\alpha \gamma^{-1}} \cap \bar{\mathfrak{b}} \quad \text{and} \quad V_\gamma := \text{Exp}(\mathfrak{v}_\gamma(\mathbb{A})). \quad (1.17)$$

Remark 1.5.1. Since Γ_i is a partial flag variety for L_i , it coincides with the group of \mathbb{K} -points of the corresponding projective algebraic variety. By the valuation criterion for properness ([Har77, Ch. II, Theorem 4.7]), it then coincides with the (integral) $O_{\mathbb{K}}$ -points of the same variety.

Theorem C. *Let η_{ntm} be a next-to-minimal automorphic function on G , let (S_α, φ) be a Whittaker pair with S_α as above and $I^{(\perp\alpha)} = (\beta_1, \dots, \beta_m)$ a quasi-abelian enumeration as above. Depending on the orbit of φ , we have the following statements for the corresponding Fourier coefficient.*

- (i) *For trivial $\varphi = 0$ the restriction of $\mathcal{F}_{S_\alpha, 0}[\eta_{\text{ntm}}]$ to the Levi subgroup L_α is a trivial, or minimal, or next-to-minimal automorphic function.*
- (ii) *For φ in the minimal orbit there exists $\gamma_0 \in L_\alpha \cap \Gamma$ such that $\psi := \text{Ad}^*(\gamma_0)\varphi \in \mathfrak{g}_{-\alpha}^\times$. For any such $\gamma_0 \in L_\alpha \cap \Gamma$, we have*

$$\mathcal{F}_{S_\alpha, \varphi}[\eta_{\text{ntm}}](g) = \mathcal{W}_\psi[\eta_{\text{ntm}}](\gamma_0 g) + \sum_{i=1}^m C_i^\psi[\eta_{\text{ntm}}](\gamma_0 g). \quad (1.18)$$

- (iii) *If φ is next-to-minimal, then there exist orthogonal simple roots α' and α'' , and an element $\gamma_0 \in \Gamma$ that is a product of an element of $L_\alpha \cap \Gamma$ and a Weyl group representative, such that $\psi := \text{Ad}^*(\gamma_0)\varphi \in \mathfrak{g}_{-\alpha'}^\times + \mathfrak{g}_{-\alpha''}^\times$. For any such γ_0 , α' and α'' , we have*

$$\mathcal{F}_{S_\alpha, \varphi}[\eta_{\text{ntm}}](g) = \int_{V_{\gamma_0}} \mathcal{W}_\psi[\eta_{\text{ntm}}](v \gamma_0 g) dv. \quad (1.19)$$

- (iv) *If φ is not in the closure of any complex next-to-minimal orbit, then $\mathcal{F}_{S_\alpha, \varphi}[\eta_{\text{ntm}}] = 0$.*

Colloquially, we will refer to the condition in (iv) as φ being in an orbit larger than next-to-minimal.

For part (i) we remark that the coefficient $\mathcal{F}_{S_\alpha,0}[\eta_{\text{ntm}}]$ is the usual constant term that can be determined using the results of [MW95]. We note also that the restriction of $\mathcal{F}_{S_\alpha,0}[\eta_{\text{ntm}}]$ to the Levi subgroup L_α can be expressed through Whittaker coefficients using Theorem B above and Theorem D below.

Remark 1.5.2. We stress that, similarly to (1.6), the right-hand side of the formula (1.19) is compatible with the equivariance of the Fourier coefficient, i.e. satisfies

$$\mathcal{F}_{S_\alpha,\varphi}[\eta_{\text{ntm}}](ug) = \chi_\varphi(u)\mathcal{F}_{S_\alpha,\varphi}[\eta_{\text{ntm}}](g) \quad (1.20)$$

for all $u \in U$. However, in contrast to the minimal case, here we need no additional constraint on γ_0 since the equivariance is automatically ensured by the integration over V_{γ_0} .

Remark 1.5.3. It is interesting to ask which Fourier coefficients are Eulerian [Gin06, Gin14]. The expectation, based on the reduction formula of [FKP14] for Eisenstein series and explicit examples checked there, is that Whittaker coefficients $\mathcal{W}_\varphi[\eta]$ of an Eisenstein series η on a group G are Eulerian if the orbit of φ lies in $\text{WS}(\eta)$. In general, the reduction formula expresses $\mathcal{W}_\varphi[\eta]$ through a *sum of generic* Whittaker coefficients on a semi-simple group determined by φ . If $\Gamma\varphi \in \text{WS}(\eta)$, this sum collapses to a single term in all known examples and since generic Whittaker coefficients on the subgroup are Eulerian this implies the same for $\mathcal{W}_\varphi[\eta]$.

For example, in the case of Eisenstein series attached to the minimal representation of E_6, E_7, E_8 it was shown in [FKP14] that $\mathcal{W}_\varphi[\eta]$ is given by just a single Whittaker coefficient on SL_2 , which is well known to be Eulerian. See also [FGKP18, Ch. 10] for more details on these and other examples. By Theorem A this implies that the parabolic Fourier coefficient $\mathcal{F}_{S_\alpha,\varphi}[\eta_{\text{min}}]$ of an Eisenstein series in the minimal representation calculated in the unipotent of a maximal parabolic determined by α should be Eulerian for simply-laced split groups.

Conversely, [KS15] show that if G is linear, simply-connected and absolutely simple, and the form η_{min} generates an irreducible representation $\pi = \bigotimes \pi_\nu$ with all local components π_ν minimal then $\mathcal{F}_{S_\alpha,\varphi}[\eta_{\text{min}}]$ is Eulerian for any abelian root α and non-zero φ with $\text{ad}^*(S_\alpha)\varphi = -2\varphi$. By Theorem A this implies that the corresponding Whittaker coefficient is Eulerian, which, using Theorem A again, implies Eulerianity of maximal parabolic Fourier coefficients for all maximal parabolics.

We expect that Theorem C will be useful to prove similar Eulerianity results for next-to-minimal representations.

By contrast, if $\Gamma\varphi \notin \text{WS}(\eta)$ the Whittaker coefficients and Fourier coefficients corresponding to φ are not expected to be Eulerian.

We can also express any next-to-minimal automorphic function in terms of its Whittaker coefficients, similar to Theorem B that treats the case of minimal automorphic functions. This is the subject of the next subsection.

1.6. Statement of Theorem D.

Notation 1.6.1. Let α be a simple root.

- (i) Let Q_α denote the parabolic subgroup of L_α with Lie algebra $(\mathfrak{l}_\alpha)_{\leq 0}^\vee$. By Lemma 3.2.1 below, Q_α is the stabilizer in L_α of the line $\mathfrak{g}_{-\alpha}^*$ as an element of the projective space of \mathfrak{g}^* . Let Γ_α denote the quotient of $L_\alpha \cap \Gamma$ by $Q_\alpha \cap \Gamma$.
- (ii) Let \mathbf{G}_α denote the subgroup of \mathbf{G} corresponding to the simple component of \mathfrak{g} corresponding to α . Let α_{\max} denote the highest root of \mathbf{G}_α .
- (iii) We say that α is *nice* if one of the following holds:
 - (a) α is an abelian root.
 - (b) \mathbf{G}_α is of type E and α is a Heisenberg root.

We exclude the Heisenberg root in type D_n for several reasons. One is that it does not correspond to an extreme node in the Dynkin diagram. We shall explain others in §4.3 below, see in particular Remark 4.3.8 and Lemma 4.3.3.
- (iv) If α is an abelian root, define $\delta_\alpha := \alpha_{\max}$. If α is a nice Heisenberg root, define $\delta_\alpha := \alpha_{\max} - \alpha - \beta_\alpha$, where β_α is the only simple root non-orthogonal to α . One can see that β_α is unique by Table 1. For more details on δ_α , and the proof that it is a root, see §4.3 below.
- (v) Let R_α denote the parabolic subgroup of L_α with Lie algebra $(\mathfrak{l}_\alpha)_{\leq 0}^{\delta_\alpha \vee}$. Denote $\Lambda_\alpha := (L_\alpha \cap \Gamma)/(Q_\alpha \cap R_\alpha \cap \Gamma)$. In §4.3.1 below we show that $Q_\alpha \cap R_\alpha \cap \Gamma$ is a subgroup of index two in the stabilizer in $L_\alpha \cap \Gamma$ of the plane $\mathfrak{g}_{-\alpha}^* \oplus \mathfrak{g}_{-\delta_\alpha}^*$ as a point in the Grassmanian of planes in \mathfrak{g}^* .
- (vi) Let M_α denote the Levi subgroup of G given by simple roots orthogonal to α . Denote $\mathcal{M}_\alpha := (M_\alpha \cap \Gamma)/(M_\alpha \cap R_\alpha \cap \Gamma)$. In §4 below we show that $M_\alpha \cap R_\alpha \cap \Gamma$ is the stabilizer in $M_\alpha \cap \Gamma$ of the plane $\mathfrak{g}_{-\alpha}^* \oplus \mathfrak{g}_{-\delta_\alpha}^*$.
- (vii) If α is a Heisenberg root we define

$$\mathcal{B}_\alpha := \{\text{positive roots } \beta : \langle \alpha, \beta \rangle = 1\}, \quad \Omega_\alpha = \text{Exp}\left(\bigoplus_{\beta \in \mathcal{B}_\alpha} \mathfrak{g}_{-\beta}\right). \quad (1.21)$$

We also fix a representative $\gamma_\alpha \in \Gamma$ for the Weyl group element $s_\alpha s_{\alpha_{\max}} s_\alpha$, where s_α and $s_{\alpha_{\max}}$ denote the corresponding reflections.

Theorem D. *Let η_{ntm} be a next-to-minimal automorphic function on G , and let α be a nice simple root of \mathfrak{g} .*

- (i) *If α is an abelian root and $\langle \alpha, \alpha_{\max} \rangle > 0$ then*

$$\eta_{\text{ntm}} = \mathcal{F}_{S_\alpha, 0}[\eta_{\text{ntm}}] + \sum_{\gamma \in \Gamma_\alpha} \sum_{\varphi \in \mathfrak{g}_{-\alpha}^\times} \mathcal{F}_{S_\alpha, \varphi}[\eta_{\text{ntm}}](\gamma g). \quad (1.22)$$

Denote the right-hand side of (1.22) by \mathcal{A}' , for any nice α .

- (ii) *If α is an abelian root and $\langle \alpha, \alpha_{\max} \rangle = 0$ then*

$$\eta_{\text{ntm}} = \mathcal{A}' + \frac{1}{2} \sum_{\gamma \in \Lambda_\alpha} \sum_{\substack{\varphi \in \mathfrak{g}_{-\alpha}^\times \\ \psi \in \mathfrak{g}_{-\delta_\alpha}^\times}} \mathcal{F}_{S_\alpha, \varphi + \psi}[\eta_{\text{ntm}}](\gamma g). \quad (1.23)$$

Denote the right-hand side of (1.23) by \mathcal{A} .

(iii) If α is a nice Heisenberg root then

$$\eta_{\text{ntm}} = \mathcal{A} + \sum_{\omega \in \Omega_\alpha} \left(\sum_{\varphi \in \mathfrak{g}_{-\alpha}^\times} \mathcal{F}_{S_\alpha, \varphi}[\eta_{\text{ntm}}](\omega \gamma_\alpha g) + \sum_{\gamma \in \mathcal{M}_\alpha} \sum_{\substack{\varphi \in \mathfrak{g}_{-\alpha}^\times \\ \psi \in \mathfrak{g}_{-\delta_\alpha}^\times}} \mathcal{F}_{S_\alpha, \varphi + \psi}[\eta_{\text{ntm}}](\gamma \omega \gamma_\alpha g) \right). \quad (1.24)$$

Part (i) of the above theorem only arises in type A when α is an extreme root of the diagram, part (ii) applies to all other roots in type A and to all abelian roots in types D and E . Part (iii) only applies to type E and more specifically to root α_2 for E_6 , root α_1 for E_7 and root α_8 for E_8 using Bourbaki numbering. Note that δ_α appearing in \mathcal{A} in parts (ii) and (iii) is as defined in Notation 1.6.1(iv) and differs in the two parts.

The right-hand sides of (1.22), (1.23) and (1.24) can be expressed in terms of Whittaker coefficients. Indeed, $\mathcal{F}_{S_\alpha, \varphi + \psi}[\eta_{\text{ntm}}]$ and $\mathcal{F}_{S_\alpha, \varphi}[\eta_{\text{ntm}}]$ can be expressed using Theorem C, while $\mathcal{F}_{S_\alpha, 0}[\eta_{\text{ntm}}]$ defines a next-to-minimal function on L_α , that can then be further decomposed using Theorem D by induction on the rank of G . To present this decomposition we will need some further notation.

1.7. Statements of Theorems E, F and G.

Notation 1.7.1. Let β_1, \dots, β_n be a quasi-abelian enumeration such that $\beta_1, \dots, \beta_{n-1}$ is an abelian enumeration for L_{n-1} . In this notation we define the terms A_{ij}, B_{nj} to be used in the next two theorems.

- (i) For any $i \leq n$ we define A_{ii} in the following way. Let α_{max}^i denote the highest root for the simple component of \mathfrak{l}_i containing β_i . If β_i is abelian in \mathfrak{l}_i and α_{max}^i is not orthogonal to β_i we set $A_{ii} = 0$. Otherwise we define δ_i to be the root δ_{β_i} of \mathfrak{l}_i , and fix a $g_i \in \Gamma$ that normalizes the torus and conjugates β_i and δ_i to orthogonal simple roots. Such a g_i exists by Corollary 3.0.4. Define V_{g_i} as in (1.17) and set

$$A_{ii} := \frac{1}{2} \sum_{\tilde{\gamma} \in \Lambda_{\beta_i}} \sum_{\varphi \in \mathfrak{g}_{-\beta_i}^\times} \sum_{\psi \in \mathfrak{g}_{-\delta_i}^\times} \int_{V_{g_i}} \mathcal{W}_{\varphi + \psi}[\eta_{\text{ntm}}](v g_i \tilde{\gamma} g) dv, \quad (1.25)$$

where Λ_{β_i} is the quotient of $L_{i-1} \cap \Gamma$ defined as in Notation 1.6.1(v) above.

- (ii) Let $j < i$ such that $\langle \beta_i, \beta_j \rangle = 0$. We define

$$A_{ij}[\eta] = \sum_{\gamma' \in \Gamma_{i-1}} \sum_{\varphi \in \mathfrak{g}_{-\beta_i}^\times} \sum_{\gamma \in \Gamma_{j-1}} \sum_{\psi \in \mathfrak{g}_{-\beta_j}^\times} \mathcal{W}_{\varphi + \psi}[\eta_{\text{ntm}}](\gamma \gamma' g). \quad (1.26)$$

- (iii) If β_n is Heisenberg, fix a representative $\gamma_n \in \Gamma$ for the Weyl group element $s_{\beta_n} s_{\alpha_{\text{max}}^n} s_{\beta_n}$, where s_{β_n} and $s_{\alpha_{\text{max}}^n}$ denote the corresponding reflections.
- (iv) We will write $j \perp i$ if $\langle \beta_j, \beta_i \rangle = 0$.
- (v) For any index j with $j \perp n$ we define B_{nj} in the following way. If β_n is abelian we set $B_{nj} := 0$. For Heisenberg β_n we define L'_j to be the Levi subgroup of G given by the roots β_k with $k < j$ and $k \perp n$, Q'_{j-1} to be the subgroup of L'_{j-1} that stabilizes the root space $\mathfrak{g}_{-\beta_j}^*$, and $\Gamma'_{j-1} := (L'_{j-1} \cap \Gamma) / (Q'_{j-1} \cap \Gamma)$. Set

$$B_{nj} := \sum_{\omega \in \Omega_n} \sum_{\varphi \in \mathfrak{g}_{-\beta_n}^\times} \sum_{\gamma \in \Gamma'_{j-1}} \sum_{\psi \in \mathfrak{g}_{-\beta_j}^\times} \mathcal{W}_{\varphi+\psi}[\eta_{\text{ntm}}](\gamma\omega\gamma_n g). \quad (1.27)$$

(vi) If β_n is abelian, we define B_{nn} to be zero. If β_n is Heisenberg and nice, we define

$$B_{nn} := \sum_{\omega \in \Omega_n} \sum_{\tilde{\gamma} \in \mathcal{M}_{\beta_n}} \sum_{\varphi \in \mathfrak{g}_{-\beta_n}^\times} \sum_{\psi \in \mathfrak{g}_{-\delta_n}^\times} \int_V \mathcal{W}_{\varphi+\psi}[\eta_{\text{ntm}}](v\tilde{\gamma}\omega\gamma_n g) dv. \quad (1.28)$$

Recall also the notation A_i, B_i from (1.9) and (1.11). Applying Theorem D by induction and using also Theorems B and C, we obtain the following theorem.

Theorem E. *Fix a quasi-abelian enumeration β_1, \dots, β_n such that $\beta_1, \dots, \beta_{n-1}$ is an abelian enumeration for L_{n-1} , and β_n is a nice quasi-abelian root. Let η_{ntm} be a next-to-minimal automorphic function on G . Then*

$$\eta_{\text{ntm}} = \mathcal{W}_0[\eta_{\text{ntm}}] + \sum_i (A_i + A_{ii} + \sum_{j < i, j \perp i} A_{ij}) + B_n + B_{nn} + \sum_{j \perp n} B_{nj}. \quad (1.29)$$

We note that if \mathfrak{g} has at most one component of type E_8 then an enumeration as in Theorem E is always possible. For example one can take the Bourbaki enumeration on each component. Note that the right-hand side of (1.29) is entirely expressed in terms of Whittaker coefficients.

One can simplify the expression in (1.29) by allowing oneself to use in the final expression not only Whittaker coefficients, but also constant terms with respect to parabolic nilradicals, that in turn can be determined for Eisenstein series using [MW95]. In this way one obtains the following statement.

Theorem F. *Assume that $[\mathfrak{g}, \mathfrak{g}]$ is simple of rank n , and fix the Bourbaki enumeration of its simple roots. Let η_{ntm} be a next-to-minimal automorphic function on G . Then*

(i) *In type A we have*

$$\eta_{\text{ntm}} = \mathcal{F}_{S_{\alpha_n}, 0}[\eta_{\text{ntm}}] + A_n + \sum_{j \perp n} A_{nj}.$$

(ii) *In types D, E_6 and E_7 we have*

$$\eta_{\text{ntm}} = \mathcal{F}_{S_{\alpha_n}, 0}[\eta_{\text{ntm}}] + A_n + \sum_{j \perp n} A_{nj} + A_{nn}.$$

(iii) *In type E_8 we have*

$$\eta_{\text{ntm}} = \mathcal{F}_{S_{\alpha_n}, 0}[\eta_{\text{ntm}}] + A_n + \sum_{j \perp n} A_{nj} + A_{nn} + B_n + \sum_{j \perp n} B_{nj} + B_{nn}.$$

Using Lemma 2.0.7 below on the connection of Fourier coefficients to wave-front sets of local components we derive from Theorem E the following one.

Theorem G. *Let π be an irreducible representation of G and let $\pi = \bigotimes \pi_\nu$ be a decomposition of π to local components. Suppose that there exists ν such that π_ν is minimal or next-to-minimal. Then π cannot be realized in cuspidal automorphic forms on G .*

For statements on the possibility of decomposing $\pi = \otimes \pi_\nu$ into local factors for covering groups, see [Wei18, §8].

1.8. Illustrative examples. Theorems A and B build upon and extend the results of [GRS97, MS12] for automorphic forms in the minimal representation. For the next-to-minimal representation, Theorems C and D were established in [AGK⁺18] for SL_n and are here generalized to arbitrary simply-laced split Lie groups G . Together with Theorem D they provide explicit expressions for the complete Fourier expansions of next-to-minimal automorphic forms on all split simply-laced groups.

In order to illustrate the types of explicit expansions one obtains we here give the expansion of minimal and next-to-minimal automorphic forms on E_8 using the α_8 parabolic. For a minimal automorphic form one obtains

$$\eta_{\min}(g) = \mathcal{F}_{S_{\alpha_8}, 0}[\eta_{\min}](g) + \sum_{\gamma \in \Gamma_7} \sum_{\varphi \in \mathfrak{g}_{-\alpha_8}^\times} \mathcal{W}_\varphi[\eta_{\min}](\gamma g) + \sum_{\omega \in \Omega_8} \sum_{\varphi \in \mathfrak{g}_{-\alpha_8}^\times} \mathcal{W}_\varphi[\eta_{\min}](\omega \gamma_8 g), \quad (1.30)$$

while for a next-to-minimal automorphic form we have a slightly more complicated expression

$$\begin{aligned} \eta_{\mathrm{ntm}}(g) = & \underbrace{\sum_{\gamma \in \Gamma_7} \sum_{\varphi \in \mathfrak{g}_{-\alpha_8}^\times} \mathcal{W}_\varphi(\gamma g)}_{A_8} + \underbrace{\sum_{j=1}^6 \sum_{\gamma' \in \Gamma_7} \sum_{\varphi \in \mathfrak{g}_{-\alpha_8}^\times} \sum_{\gamma \in \Gamma_{j-1}} \sum_{\psi \in \mathfrak{g}_{-\beta_j}^\times} \mathcal{W}_{\varphi+\psi}(\gamma \gamma' g)}_{A_{8j}} \\ & + \underbrace{\frac{1}{2} \sum_{\tilde{\gamma} \in \Lambda_{\alpha_8}} \sum_{\varphi \in \mathfrak{g}_{-\alpha_8}^\times} \sum_{\psi \in \mathfrak{g}_{-\delta_8}^\times} \int_{V_{g_8}} \mathcal{W}_{\varphi+\psi}(v g_8 \tilde{\gamma} g) dv}_{A_{88}} + \underbrace{\sum_{\omega \in \Omega_8} \sum_{\varphi \in \mathfrak{g}_{-\alpha_8}^\times} \mathcal{W}_\varphi(\omega \gamma_8 g)}_{B_8} \\ & + \underbrace{\sum_{\omega \in \Omega_8} \sum_{\tilde{\gamma} \in \mathcal{M}_{\alpha_8}} \sum_{\varphi \in \mathfrak{g}_{-\alpha_8}^\times} \sum_{\psi \in \mathfrak{g}_{-\delta_8}^\times} \int_V \mathcal{W}_{\varphi+\psi}(v \tilde{\gamma} \omega \gamma_8 g) dv}_{B_{88}} \\ & + \underbrace{\sum_{j=1}^6 \sum_{\omega \in \Omega_8} \sum_{\varphi \in \mathfrak{g}_{-\alpha_8}^\times} \sum_{\gamma \in \Gamma'_{j-1}} \sum_{\psi \in \mathfrak{g}_{-\beta_j}^\times} \mathcal{W}_{\varphi+\psi}(\gamma \omega \gamma_8 g)}_{B_{8j}}. \end{aligned} \quad (1.31)$$

All coefficients are evaluated for the automorphic form $\eta = \eta_{\mathrm{ntm}}$. The elements g_8 and γ_8 are defined in §1.7 and §1.4, respectively,

We shall compare these to other results available in the literature in §5.2.2.

1.9. Motivation from string theory. The results of this paper have applications in string theory. In short, string theory predicts certain quantum corrections to Einstein's theory of general relativity. These quantum corrections come in the form of an expansion in curvature tensors and their derivatives. The first non-trivial correction is of fourth order in the Riemann tensor, denoted schematically \mathcal{R}^4 , and has a coefficient which is a function

$\eta_n : E_n/K_n \rightarrow \mathbb{R}$, where E_n/K_n is a particular symmetric space, the classical moduli space of the theory. The parameter $n = d + 1$ contains the number of spacetime dimensions d that have been compactified on a torus T^d . The groups E_n are all split real forms of rank n complex Lie groups (see table 2).

TABLE 2. Table of Cremmer–Julia symmetry groups $E_n(\mathbb{R})$, $n = d+1$, with compact subgroup $K_n(\mathbb{R})$ and U-duality groups $E_n(\mathbb{Z})$ for compactifications of IIB string theory on a d -dimensional torus T^d to $D = 10 - d$ dimensions.

d	$E_{d+1}(\mathbb{R})$	$K_{d+1}(\mathbb{R})$	$E_{d+1}(\mathbb{Z})$
0	$\mathrm{SL}_2(\mathbb{R})$	$\mathrm{SO}_2(\mathbb{R})$	$\mathrm{SL}_2(\mathbb{Z})$
1	$\mathrm{SL}_2(\mathbb{R}) \times \mathbb{R}_+$	$\mathrm{SO}_2(\mathbb{R})$	$\mathrm{SL}_2(\mathbb{Z})$
2	$\mathrm{SL}_2(\mathbb{R}) \times \mathrm{SL}_3(\mathbb{R})$	$\mathrm{SO}_2(\mathbb{R}) \times \mathrm{SO}_3(\mathbb{R})$	$\mathrm{SL}_2(\mathbb{Z}) \times \mathrm{SL}_3(\mathbb{Z})$
3	$\mathrm{SL}_5(\mathbb{R})$	$\mathrm{SO}_5(\mathbb{R})$	$\mathrm{SL}_5(\mathbb{Z})$
4	$\mathrm{Spin}_{5,5}(\mathbb{R})$	$\mathrm{Spin}_5(\mathbb{R}) \times \mathrm{Spin}_5(\mathbb{R})$	$\mathrm{Spin}_{5,5}(\mathbb{Z})$
5	$E_6(\mathbb{R})$	$\mathrm{USp}_8(\mathbb{R})/\mathbb{Z}_2$	$E_6(\mathbb{Z})$
6	$E_7(\mathbb{R})$	$\mathrm{SU}_8(\mathbb{R})/\mathbb{Z}_2$	$E_7(\mathbb{Z})$
7	$E_8(\mathbb{R})$	$\mathrm{Spin}_{16}(\mathbb{R})/\mathbb{Z}_2$	$E_8(\mathbb{Z})$

In the full quantum theory the classical symmetry $E_n(\mathbb{R})$ is broken to an arithmetic subgroup $E_n(\mathbb{Z})$, called the *U-duality group*, which is the Chevalley group of integer points of E_n [HT95]. Thus, the coefficient functions η_n are really functions on the double coset $E_n(\mathbb{Z}) \backslash E_n(\mathbb{R}) / K_n$ and in certain cases they can be uniquely determined. For the two leading order quantum corrections, corresponding to \mathcal{R}^4 and $\partial^4 \mathcal{R}^4$, the coefficient functions η_n are respectively attached to the minimal and next-to-minimal automorphic representations of E_n [Pio10, GMV15]. Fourier expanding η_n with respect to various unipotent subgroups $U \subset E_n$ reveals interesting information about perturbative and non-perturbative quantum effects. Of particular interest are the cases when U is the unipotent radical of a maximal parabolic $P_\alpha \subset G$ corresponding to a simple root α at an “extreme” node (or end node) in the Dynkin diagram. Consider the sequence of groups E_n displayed in table 2, and the associated Dynkin diagram in “Bourbaki labelling”. The extreme simple roots are then α_1, α_2 and α_n (this is slightly modified for the low rank cases where the Dynkin diagram becomes disconnected). Fourier expanding the automorphic form η with respect to the corresponding maximal parabolics then have the following interpretations (see figure 1 for the associated labelled Dynkin diagrams):

- $P = P_{\alpha_1}$: **String perturbation limit.** In this case the constant term of the Fourier expansion corresponds to perturbative terms (tree level, one-loop etc.) with respect to an expansion around small string coupling, $g_s \rightarrow 0$. The non-constant Fourier coefficients encode non-perturbative effects of the order e^{-1/g_s} and e^{-1/g_s^2} arising from so-called D-instantons and NS5-instantons.
- $P = P_{\alpha_2}$: **M-theory limit.** This is an expansion in the limit of large volume of the M-theory torus T^{d+1} . The non-perturbative effects arise from M2- and M5-brane instantons.
- $P = P_{\alpha_n}$: **Decompactification limit.** This is an expansion in the limit of large volume of a single circle S^1 in the torus T^d (or T^{d+1} in the M-theory picture). The

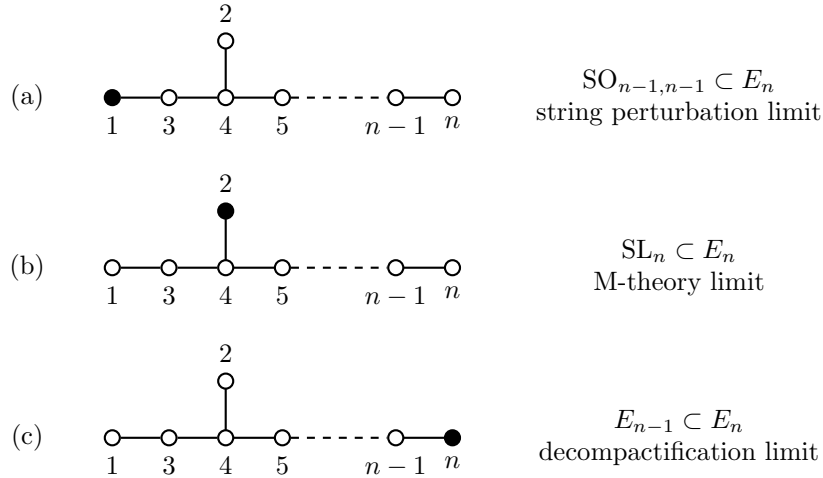

FIGURE 1. The various string theory limits associated with different maximal parabolic subgroups P_α . Roots are labeled in the Bourbaki ordering.

non-perturbative effects encoded in the non-constant Fourier coefficients correspond to so called BPS-instantons and Kaluza–Klein instantons.

For the reasons presented above, it is of interest in string theory to have general techniques for explicitly calculating Fourier coefficients of automorphic forms with respect to arbitrary unipotent subgroups.

In string theory the abelian and non-abelian Fourier coefficients of the type defined in (1.1) typically reveal different types of non-perturbative effects (see for instance [PP09, BKN⁺10, Per12]). The archimedean and non-archimedean parts of the adelic integrals have different interpretations in terms of combinatorial properties of instantons and the instanton action, respectively. For example, in the simplest case of an Eisenstein series on SL_2 the non-archimedean part is a divisor sum $\sigma_k(n) = \sum_{d|n} d^k$ and corresponds to properties of D-instantons [GG97, GG98, KV98, MNS00] (see also [FGKP18] for a detailed discussion in the present context). Theorem F provides explicit expressions for the Fourier coefficients of the automorphic coupling of the next-to-minimal $\partial^4 \mathcal{R}^4$ higher derivative correction in various limits; see section 5.2 for a more detailed discussion in the case of E_8 .

Remark 1.9.1. Theorem G resolves a long-standing question in string theory which concerns the possibility of having contributions from cusp forms in the \mathcal{R}^4 and $\partial^4 \mathcal{R}^4$ amplitudes. The theorem ensures that this can never happen as there are no cusp forms in the minimal or next-to-minimal spectrum.

1.10. Structure of the paper. In §2 we give the definitions of the notions mentioned above.

In §2.2 we introduce the results of [GGK⁺] that relate Fourier coefficients corresponding to different Whittaker pairs, in particular Theorem 2.2.6, which is the main tool of the current paper. Two more results from [GGK⁺] that we recall in §2.2 and heavily use in the

rest of the paper are Proposition 2.2.7 that expresses any automorphic function through Heisenberg parabolic Fourier coefficients, and a geometric Lemma 2.2.8.

In §3 we deduce Theorems A-C from §2.2. We first deduce from Lemma 2.2.8 that any minimal $\varphi \in (\mathfrak{g}^*)_{-2}^{S_\alpha}$ can be conjugated into $\mathfrak{g}_{-\alpha}^\times$ using $L_\alpha \cap \Gamma$ (Corollary 3.1.3). This, together with Theorem 2.2.6, implies Theorem A(ii). Part (iii) of Theorem A follows from the definition of minimality and Corollary 2.2.5, which says that any Fourier coefficient is linearly determined by a neutral Fourier coefficient corresponding to the same orbit.

To prove Theorem B, assume first that $\alpha := \beta_n$ is an abelian root. In this case we decompose the form η_{\min} into Fourier series with respect to U_α . Each Fourier coefficient is of the form $\mathcal{F}_{S_\alpha, \varphi}$. For $\varphi = 0$, the restriction of this coefficient to L_α is minimal and we use the theorem for L_α (by induction on rank). For non-zero and non-minimal φ , $\mathcal{F}_{S_\alpha, \varphi}$ vanishes by Theorem A(iii). For minimal φ the expressions for $\mathcal{F}_{S_\alpha, \varphi}$ are given by Theorem A(ii). We group them together using Corollary 3.1.3. If α is a Heisenberg root, we express η_{\min} through parabolic Fourier coefficients $\mathcal{F}_{S_\alpha, \varphi}$ using Proposition 2.2.7. For $\varphi \neq 0$, $\mathcal{F}_{S_\alpha, \varphi}$ is given by Theorem A, and for $\varphi = 0$ by induction.

To prove Theorem C(ii) we restrict $\mathcal{F}_{S_\alpha, \varphi}[\eta_{\text{ntm}}]$ to L_α , show that it is a minimal automorphic function and apply Theorem B. Theorem C(iii) and C(iv) follow from Theorem 2.2.6 and Corollary 2.2.5 respectively. For Theorem C(iii) we also use a geometric lemma saying that any next-to-minimal $\varphi \in (\mathfrak{g}^*)_{-2}^{S_\alpha}$ can be conjugated into $\mathfrak{g}_{-\alpha}^\times + \mathfrak{g}_{-\beta}^\times$ for some positive root β orthogonal to α using $L_\alpha \cap \Gamma$ (Lemma 3.3.6).

In §4 we first prove Theorem D and its corollaries using the same strategy as in the proof of Theorem B. However, we need two additional geometric propositions (Propositions 4.0.1 and 4.1.2) that describe the action of L_α on next-to-minimal elements of $(\mathfrak{g}^*)_{-2}^{S_\alpha}$. We prove these in §4.3. In §4.2 we derive Theorems E, F, and G from Theorems B, C, and D.

In §5 we provide examples of Theorems A-D for groups of type D_5 and E_8 computing the expansions of automorphic function and Fourier coefficients with respect to different parabolic subgroups of interest in string theory and compare our E_8 results to the available literature [BP17, GKP16, KP04].

1.11. Acknowledgements. We are grateful for helpful discussions with Guillaume Bossard, Ben Brubaker, Daniel Bump, Solomon Friedberg, David Ginzburg, Joseph Hundley, Stephen D. Miller, Manish Patnaik, Boris Pioline and Gordan Savin. We also thank the Banff International Research Station for Mathematical Innovation and Discovery and the Simons Center for Geometry and Physics for their hospitality during different stages of this project. D.G. was partially supported by ERC StG grant 637912. H.G was supported by the Knut and Alice Wallenberg Foundation. D.P. was supported by the Swedish Research Council (Vetenskapsrådet), grant nr. 2018-04760. S.S. was partially supported by Simons Foundation grant 509766.

2. DEFINITIONS AND PRELIMINARIES

Let \mathbb{K} be a number field and let $\mathbb{A} = \mathbb{A}_{\mathbb{K}}$ be its ring of adèles. Fix a non-trivial unitary character χ of \mathbb{A} , which is trivial on \mathbb{K} . Then χ defines an isomorphism between \mathbb{A} and $\hat{\mathbb{A}}$ via the map $a \mapsto \chi_a$, where $\chi_a(b) = \chi(ab)$ for all $b \in \mathbb{A}$. This isomorphism restricts to an

isomorphism

$$\widehat{\mathbb{A}/\mathbb{K}} \cong \{r \in \hat{\mathbb{A}} : |r|_{\mathbb{K}} \equiv 1\} = \{\chi_a : a \in \mathbb{K}\} \cong \mathbb{K}. \quad (2.1)$$

Let \mathbf{G} be a reductive group defined over \mathbb{K} , $\mathbf{G}(\mathbb{A})$ the group of adelic points of \mathbf{G} and G be a finite central extension of $\mathbf{G}(\mathbb{A})$. We assume that there exists a section $\mathbf{G}(\mathbb{K}) \rightarrow G$ of the covering $p : G \rightarrow \mathbf{G}(\mathbb{A})$, fix such a section and denote its image by Γ . By [MW95, Appendix I], for any unipotent subgroup $\mathbf{U} \subset \mathbf{G}$, p has a canonical section on $\mathbf{U}(\mathbb{A})$. We will always use this to identify $\mathbf{U}(\mathbb{A})$ with a subgroup of G . Let \mathfrak{g} denote the Lie algebra of $\mathbf{G}(\mathbb{K}) \cong \Gamma$.

For a nilpotent subalgebra $\mathfrak{v} \subset \mathfrak{g}$, we denote by $\text{Exp}(\mathfrak{v})$ the unipotent subgroup of Γ obtained by exponentiation of \mathfrak{v} . Similarly, we denote by $V := \text{Exp}(\mathfrak{v}(\mathbb{A}))$ the unipotent subgroup of G obtained by exponentiation of the adelicization $\mathfrak{v}(\mathbb{A}) := \mathfrak{v} \otimes_{\mathbb{K}} \mathbb{A}$.

Definition 2.0.1. A *Whittaker pair* is an ordered pair $(S, \varphi) \in \mathfrak{g} \times \mathfrak{g}^*$ such that S is a rational semi-simple element (that is, with eigenvalues of the adjoint action $\text{ad}(S)$ in \mathbb{Q}), and $\text{ad}^*(S)(\varphi) = -2\varphi$.

We will say that an element of \mathfrak{g}^* is *nilpotent* if it is given by the Killing form pairing with a nilpotent element of \mathfrak{g} . Equivalently, $\varphi \in \mathfrak{g}^*$ is nilpotent if and only if the Zariski closure of its coadjoint orbit includes zero. For example, if (S, φ) is a Whittaker pair then φ is nilpotent.

For any rational semi-simple $S \in \mathfrak{g}$ and $i \in \mathbb{Q}$ we set

$$\mathfrak{g}_i^S := \{X \in \mathfrak{g} : [S, X] = iX\}, \quad \mathfrak{g}_{>i}^S := \bigoplus_{j>i \in \mathbb{Q}} \mathfrak{g}_j^S, \quad \text{and} \quad \mathfrak{g}_{\geq i}^S := \mathfrak{g}_i^S \oplus \mathfrak{g}_{>i}^S. \quad (2.2)$$

We will also use similar notation for $(\mathfrak{g}^*)_i^S$.

For any $\varphi \in \mathfrak{g}^*$ we define an anti-symmetric form ω_φ of \mathfrak{g} by

$$\omega_\varphi(X, Y) = \varphi([X, Y]). \quad (2.3)$$

Given a Whittaker pair (S, φ) on \mathfrak{g} , we set $\mathfrak{u} := \mathfrak{g}_{>1}^S \oplus \mathfrak{g}_1^S$ and define

$$\mathfrak{n}_{S, \varphi} := \{X \in \mathfrak{u} : \omega_\varphi(X, Y) = 0 \text{ for all } Y \in \mathfrak{u}\} \quad \text{and} \quad N_{S, \varphi} := \text{Exp } \mathfrak{n}_{S, \varphi}(\mathbb{A}) \quad (2.4)$$

By [GGS17, Lemma 3.2.6],

$$\mathfrak{n}_{S, \varphi} = \mathfrak{g}_{>1}^S \oplus (\mathfrak{g}_1^S \cap \mathfrak{g}_\varphi), \quad (2.5)$$

where \mathfrak{g}_φ is the centralizer of φ in \mathfrak{g} under the coadjoint action. Note that $\mathfrak{n}_{S, \varphi}$ is an ideal in \mathfrak{u} with abelian quotient, and that φ defines a character of $\mathfrak{n}_{S, \varphi}$. Define an automorphic character on $N_{S, \varphi}$ by $\chi_\varphi(\exp X) := \chi(\varphi(X))$. For a unipotent subgroup $U \subset G$ we denote by $[U]$ the quotient $(U \cap \Gamma) \backslash U$.

We call a function on G an *automorphic function* if it is left Γ -invariant, finite under the right action of the preimage in G of $\prod_{\text{finite } \nu} \mathbf{G}(\mathcal{O}_\nu)$, and smooth when restricted to the preimage in G of $\prod_{\text{infinite } \nu} \mathbf{G}(\mathbb{K}_\nu)$. We denote the space of all automorphic functions by $C^\infty(\Gamma \backslash G)$.

Definition 2.0.2. For an automorphic function η , we define the *Fourier coefficient* of η with respect to a Whittaker pair (S, φ) to be

$$\mathcal{F}_{S,\varphi}[\eta](g) := \int_{[N_{S,\varphi}]} \eta(n g) \chi_\varphi(n)^{-1} dn. \quad (2.6)$$

Definition 2.0.3. A Whittaker pair (H, φ) is called a neutral Whittaker pair if either $(H, \varphi) = (0, 0)$, or H can be completed to an \mathfrak{sl}_2 -triple (e, H, f) such that φ is the Killing form pairing with f . Equivalently, the coadjoint action on φ defines an epimorphism $\mathfrak{g}_0^H \rightarrow (\mathfrak{g}^*)_{-2}^H$, and also H can be completed to an \mathfrak{sl}_2 -triple. For more details on \mathfrak{sl}_2 -triples over arbitrary fields of characteristic zero see [Bou75, §11].

Definition 2.0.4. We call a Whittaker pair (S, φ) *standard* if $N_{S,\varphi}$ is the unipotent radical of a Borel subgroup of G . By [GGK⁺, Corollary 2.1.5], a nilpotent $\varphi \in \mathfrak{g}^*$ can be completed to a standard Whittaker pair if and only if it is a principal nilpotent element of some \mathbb{K} -Levi subgroup of G . Here, principal means that the dimension of its centralizer equals the rank of the group. We call such φ *PL-nilpotent*, and their orbits *PL-orbits*. For a standard pair (S, φ) , we call the Fourier coefficient $\mathcal{F}_{S,\varphi}$ a *Whittaker coefficient* and denote it $\mathcal{W}_{S,\varphi}$, or \mathcal{W}_φ if S defines the fixed Borel subgroup, see (1.5).

Remark 2.0.5. (i) In [GGS17, §6] the integral (2.6) above is called a Whittaker–Fourier coefficient, but in this paper we call it Fourier coefficient for short. The Whittaker coefficients are called in [GGS17, §6] principal degenerate Whittaker–Fourier coefficients. The notation $\mathcal{W}_{S,\varphi}$ and \mathcal{W}_φ is used in [GGS17, GGS] to denote something quite different.
(ii) Note that for $G = \mathrm{GL}_n$ all orbits \mathcal{O} are PL-orbits. In general this is, however, not the case, see [GGK⁺, Appendix A].
(iii) We refer the readers interested in the definitions of principal nilpotents, PL-nilpotents, and standard pairs for non-quasi-split groups to [GGK⁺, §2.1].

Definition 2.0.6. For an automorphic function η , we define $\mathrm{WO}(\eta)$ to be the set of nilpotent orbits \mathcal{O} under Γ in \mathfrak{g}^* such that $\mathcal{F}_{h,\varphi}[\eta] \neq 0$ for some neutral Whittaker pair (h, φ) with $\varphi \in \mathcal{O}$. We define the *Whittaker support* $\mathrm{WS}(\eta)$ to be the set of maximal elements in $\mathrm{WO}(\eta)$.

The following well known lemma relates these notions to the local notion of wave-front set. For a survey on this notion, and its relation to degenerate Whittaker models we refer the reader to [GS18, §4].

Lemma 2.0.7. *Suppose that η is an automorphic form in the classical sense, and that it generates an irreducible representation π of G . Let $\pi = \bigotimes_\nu \pi_\nu$ be the decomposition of π to local factors. Let $\mathcal{O} \in \mathrm{WO}(\eta)$. Then, for any ν , there exists an orbit \mathcal{O}'_ν in the wave-front set of π_ν such that \mathcal{O} lies in the Zariski closure of \mathcal{O}'_ν . Moreover, if ν is non-archimedean, then \mathcal{O} lies in the closure of \mathcal{O}'_ν in the topology of $\mathfrak{g}^*(\mathbb{K}_\nu)$.*

Proof. Acting by G on the argument of η we can assume that there exists a neutral pair (h, φ) with $\varphi \in \mathcal{O}$ such that $\mathcal{F}_{h,\varphi}[\eta](1) \neq 0$. Moreover, decomposing η to a sum of pure tensors, and replacing η by one of the summands, we can assume that η is a pure tensor and $\mathcal{F}_{h,\varphi}[\eta](1) \neq 0$

still holds. Let $\eta = \bigotimes'_\mu v_\mu$ be the decomposition of η to local factors. Consider the functional ξ on π_ν given by $\xi(v) := \mathcal{F}_{h,\varphi}(v_\nu \otimes (\bigotimes'_{\mu \neq \nu} v_\mu))(1)$. Substituting the vector v_ν we see that this functional is non-zero. It is easy to see that this ξ is $(\exp(\mathfrak{n}_{h,\varphi}(\mathbb{K}_\nu)), \chi_\varphi)$ -equivariant. The theorem follows now from [MW87, Proposition I.11] and [Var14] for non-Archimedean ν , and from [Ros95, Theorem D] and [Mat87] for archimedean ν . \square

For convenience, we fix a complex embedding $\sigma : \mathbb{K} \hookrightarrow \mathbb{C}$. This embedding will allow us to speak about the complex nilpotent orbit corresponding to an orbit \mathcal{O} of Γ in \mathfrak{g} . One can show using [Dok98] that the complex orbit corresponding to \mathcal{O} does not depend on σ , although we shall not use this fact. None of our statements depends on the choice of complex embedding σ .

2.1. Minimal and next-to-minimal representations. We call a non-zero complex orbit in $\mathfrak{g}^*(\mathbb{C})$ *minimal* if its Zariski closure $\overline{\mathcal{O}}$ is a disjoint union of \mathcal{O} and the zero orbit. We call a complex orbit \mathcal{O} *next-to-minimal* if \mathcal{O} does not intersect any component of \mathfrak{g} of type A_2 , and $\overline{\mathcal{O}}$ is a disjoint union of \mathcal{O} , minimal orbits, and the zero orbit.

Lemma 2.1.1. *Let \mathfrak{g} be simple and let $\mathcal{O} \subset \mathfrak{g}^*(\mathbb{C})$ be a complex nilpotent orbit. Then \mathcal{O} is minimal if and only if it has Bala-Carter label A_1 and next-to-minimal if and only if it has Bala-Carter label $A_1 \times A_1$.*

Proof. Follows from the Hasse diagrams for the closure order on nilpotent orbits. \square

Remark 2.1.2. (i) Lemma 2.1.1 only holds for simply-laced Lie algebras. Indeed, already for C_2 the minimal orbit is represented by the long root, and the next-to-minimal by the short root. Both roots of course lie in Levi subalgebras of type A_1 .
(ii) We exclude the regular orbit of A_2 because it does not behave like a next-to-minimal orbit. This behaviour is manifested by Lemma 2.1.1.

Lemma 2.1.3. *Let $\mathfrak{g} = \bigoplus_{i=1}^k \mathfrak{g}_i$, with \mathfrak{g}_i simple. Then the minimal orbits of $\mathfrak{g}^*(\mathbb{C})$ are of the form $\times_{i=1}^j \{0\} \times \mathcal{O} \times \times_{i=j+1}^k \{0\}$, with \mathcal{O} a minimal orbit. The next-to-minimal orbits of $\mathfrak{g}^*(\mathbb{C})$ are either of the same form with \mathcal{O} next-to-minimal, or of the form $\times_{i=1}^{j-1} \{0\} \times \mathcal{O} \times \times_{i=j+1}^{l-1} \{0\} \times \mathcal{O}' \times \times_{i=l+1}^k \{0\}$, where \mathcal{O} and \mathcal{O}' are minimal orbits in \mathfrak{g}_j and \mathfrak{g}_l respectively.*

Proof. If $\mathfrak{g} = \mathfrak{g}_1 \times \mathfrak{g}_2$ and $\mathcal{O} = \mathcal{O}_1 \times \mathcal{O}_2$ then $\overline{\mathcal{O}} = \overline{\mathcal{O}}_1 \times \overline{\mathcal{O}}_2$. \square

We call a (rational) element of \mathfrak{g}^* or a rational orbit in \mathfrak{g}^* *minimal/next-to-minimal* if its complex orbit is minimal/next-to-minimal.

We say that an automorphic function η is *minimal* if $\text{WS}(\eta)$ consists of minimal orbits. By [GGS17, Theorem C] (or by Proposition 2.2.4 below), this implies that $\mathcal{F}_{H,\varphi}[\eta] = 0$ for any Whittaker pair (H, φ) with φ non-zero and non-minimal. We call an automorphic function η *trivial* if $\text{WS}(\eta) = \{0\}$. By [GGS17, Corollary 8.2.2], the semi-simple part of G acts on any trivial automorphic function by $\pm \text{Id}$. We call a representation of G in automorphic functions *minimal* if all the functions in this representation are minimal or trivial.

We say that an automorphic function η is *next-to-minimal* if $\text{WS}(\eta)$ consists of next-to-minimal orbits. Again, by [GGS17, Theorem C] (or by Proposition 2.2.4 below), this

implies that $\mathcal{F}_{H,\varphi}[\eta] = 0$ for any Whittaker pair (H, φ) with φ higher than next-to-minimal. We call a representation π of G in automorphic functions *next-to-minimal* if it includes a next-to-minimal function, and all the functions in this representation are next-to-minimal, minimal or trivial. By Lemma 2.0.7, if π consists of automorphic forms in the classical sense, is non-trivial, irreducible and has a minimal local factor then it is minimal. Similarly, if it has a next-to-minimal local factor then it is minimal or next-to-minimal.

2.2. Relating different Whittaker pairs.

Lemma 2.2.1 ([GGK⁺, Lemma 3.3.1]). *Let (S, φ) be a Whittaker pair, η an automorphic function and $\gamma \in \Gamma$. Then,*

$$\mathcal{F}_{S,\varphi}[\eta](g) = \mathcal{F}_{\text{Ad}(\gamma)S, \text{Ad}^*(\gamma)\varphi}[\eta](\gamma g). \quad (2.7)$$

Definition 2.2.2. Let (H, φ) and (S, φ) be Whittaker pairs with the same φ . We will say that (H, φ) *dominates* (S, φ) if H and S commute and

$$\mathfrak{g}_\varphi \cap \mathfrak{g}_{\geq 1}^H \subseteq \mathfrak{g}_{\geq 0}^{S-H}. \quad (2.8)$$

The following lemma provides two fundamental special cases of domination.

Lemma 2.2.3. [GGK⁺, Corollary 3.2.2 and Proposition 3.2.3] *Let (S, φ) be a Whittaker pair. Then*

- (i) (S, φ) *is dominated by a neutral Whittaker pair.*
- (ii) *If φ is a PL-nilpotent then (S, φ) dominates a standard Whittaker pair.*

The importance of the domination relation is due to the next three statements.

Proposition 2.2.4 ([GGK⁺, Proposition 4.0.1]). *Let (H, φ) and (S, φ) be Whittaker pairs such that (H, φ) dominates (S, φ) , and let η be an automorphic function with $\mathcal{F}_{H,\varphi}[\eta] = 0$. Then $\mathcal{F}_{S,\varphi}[\eta] = 0$.*

Corollary 2.2.5. *Let η be an automorphic function and let (S, φ) be Whittaker pair, with $\Gamma_\varphi \notin \text{WO}(\eta)$. Then $\mathcal{F}_{H,\varphi}[\eta] = 0$.*

Theorem 2.2.6 ([GGK⁺, Theorem C(i)]). *Let η be an automorphic function on G , and let $\varphi \in \text{WS}(\eta)$. Let (H, φ) and (S, φ) be Whittaker pairs such that (H, φ) dominates (S, φ) . Denote*

$$\mathfrak{v} := \mathfrak{g}_{>1}^H \cap \mathfrak{g}_{<1}^S, \text{ and } V := \text{Exp}(\mathfrak{v}(\mathbb{A})). \quad (2.9)$$

If $\mathfrak{g}_1^H = \mathfrak{g}_1^S = 0$ then

$$\mathcal{F}_{H,\varphi}[\eta](g) = \int_V \mathcal{F}_{S,\varphi}[\eta](vg) dv. \quad (2.10)$$

We emphasize that the integral over V is an adelic integral.

For the next proposition, recall from §1.4 that we say that a simple root α is a Heisenberg root if the nilradical of the maximal parabolic subalgebra defined by α is a Heisenberg Lie algebra. All such roots for simple (simply-laced) Lie algebras are listed in the second row of Table 1 above.

Proposition 2.2.7 ([GGK⁺, Proposition 5.1.5]). *Let α be a Heisenberg root, and let α_{\max} denote the highest root of the component of \mathfrak{g} corresponding to α . Let Ω_α denote the abelian group obtained by exponentiation of the abelian Lie algebra given by the direct sum of the root spaces of negative roots β satisfying $\langle \alpha, \beta \rangle = 1$. Let γ_α be a representative of a Weyl group element that conjugates α to α_{\max} . Let*

$$\Psi_\alpha := \{ \text{root } \varepsilon \mid \langle \varepsilon, \alpha \rangle \leq 0, \varepsilon(S_\alpha) = 2 \}.$$

Then

$$\eta(g) = \sum_{\varphi \in (\mathfrak{g}^*)_{-2}^{S_\alpha}} \mathcal{F}_{S_\alpha, \varphi}[\eta](g) + \sum_{\varphi \in \mathfrak{g}_{-\alpha}^\times} \sum_{\omega \in \Omega_\alpha} \sum_{\psi \in \bigoplus_{\varepsilon \in \Psi_\alpha} \mathfrak{g}_{-\varepsilon}^*} \mathcal{F}_{S_\alpha, \varphi + \psi}[\eta](\omega \gamma_\alpha g). \quad (2.11)$$

Lemma 2.2.8 ([GGK⁺, Lemma B.0.3]). *Let $S, Z \in \mathfrak{g}$ be rational semi-simple commuting elements, let $\varphi \in \mathfrak{g}_0^Z \cap \mathfrak{g}_{-2}^S$ and $\varphi' \in \mathfrak{g}_{>0}^Z \cap \mathfrak{g}_{-2}^S$. Assume that φ is conjugate to $\varphi + \varphi'$ by $\mathbf{G}(\mathbb{C})$. Then there exist $X \in \mathfrak{g}_{>0}^Z \cap \mathfrak{g}_0^S$ and $v \in \text{Exp}(\mathfrak{g}_{>0}^Z \cap \mathfrak{g}_0^S)$ such that $\text{ad}^*(X)(\varphi) = \varphi'$ and $v(\varphi) = \varphi + \varphi'$.*

3. PROOF OF THEOREMS A, B AND C

For the whole section we assume that \mathbf{G} is split and the Dynkin diagram of \mathfrak{g} is simply-laced, i.e. all the connected components have types A, D , or E . As in §1.4, let, for any root δ , \mathfrak{g}_δ^* denote the corresponding root-subspace of \mathfrak{g}^* and $\mathfrak{g}_\delta^\times$ the set of non-zero elements of this subspace.

Lemma 3.0.1. *If $[\mathfrak{g}, \mathfrak{g}]$ is simple then any two roots are Weyl-conjugate.*

Proof. Any root is Weyl-conjugate to a simple root, and any two simple roots in a connected simply-laced diagram are Weyl-conjugate. \square

Corollary 3.0.2. *For any root δ , any $\varphi \in \mathfrak{g}_\delta^\times$ lies in a minimal orbit.*

Corollary 3.0.3. *Assume that \mathfrak{g} is simple.*

- (i) *If \mathfrak{g} is of type A or E then any two pairs of orthogonal roots are Weyl-conjugate.*
- (ii) *If \mathfrak{g} is of type D_n with $n \geq 5$ then any pair of orthogonal roots is Weyl-conjugate to exactly one of the pairs (α_1, α_3) and (α_{n-1}, α_n) .*
- (iii) *If \mathfrak{g} is of type D_4 then any pair of orthogonal roots is Weyl-conjugate to exactly one of the pairs (α_1, α_3) , (α_1, α_4) and (α_3, α_4) .*

Proof. In types A and E , we apply Lemma 3.0.1, and assume that both pairs include the highest root. Since the diagram consisting of roots orthogonal to the highest one is still connected, the stabilizer of the highest root acts transitively on it.

In type D_n we use the standard realization of roots as

$$\{ \pm \varepsilon_i \pm \varepsilon_j, \} \quad (3.1)$$

where ε_i denotes the unit vector in \mathbb{R}^n . The Weyl group acts by permutation of the indices, and even number of sign changes. The usual choice of simple roots is

$$\alpha_1 := \varepsilon_1 - \varepsilon_2, \quad \dots, \quad \alpha_{n-1} := \varepsilon_{n-1} - \varepsilon_n, \quad \alpha_n := \varepsilon_{n-1} + \varepsilon_n \quad (3.2)$$

Using reflections, we can conjugate any pair of orthogonal roots to a pair of orthogonal positive roots. The pairs of orthogonal positive roots have one of the two forms

- (1) $(\varepsilon_i + \varepsilon_j, \varepsilon_i - \varepsilon_j)$ or $(\varepsilon_i - \varepsilon_j, \varepsilon_i + \varepsilon_j)$, with $i < j$.
- (2) $(\varepsilon_i \pm \varepsilon_j, \varepsilon_k \pm \varepsilon_l)$ with $i < j$ and $k < l$ all distinct.

We can conjugate any pair of type (1) to $(\alpha_{n-1}, \alpha_n) = (\varepsilon_{n-1} - \varepsilon_n, \varepsilon_{n-1} + \varepsilon_n)$. For $n \geq 5$, any pair of type (2) is conjugate to $(\alpha_1, \alpha_3) = (\varepsilon_1 - \varepsilon_2, \varepsilon_3 - \varepsilon_4)$. For D_4 we have two non-conjugate pairs of type (2): $(\alpha_1, \alpha_3) = (\varepsilon_1 - \varepsilon_2, \varepsilon_3 - \varepsilon_4)$ or $(\alpha_1, \alpha_4) = (\varepsilon_1 - \varepsilon_2, \varepsilon_3 + \varepsilon_4)$. It is easy to see that one cannot conjugate a pair of type (1) into a pair of type (2). \square

We remark that in type D_n , the pairs (α_1, α_3) and (α_{n-1}, α_n) correspond to two distinct next-to-minimal orbits, given by the partitions $2^4 1^{2n-8}$ and $3 1^{2n-3}$ respectively.

Corollary 3.0.4. *Any pair of orthogonal roots in \mathfrak{g} is Weyl-conjugate to a pair of orthogonal simple roots.*

Proof. If $[\mathfrak{g}, \mathfrak{g}]$ is not simple and the roots lie in different simple components this follows from Lemma 3.0.1 by conjugating each of them to a simple root. If the roots lie in the same component, this follows from Corollary 3.0.3. \square

3.1. Proof of Theorem A. Throughout the subsection fix a simple root α . Define $S_\alpha \in \mathfrak{h}$ by $\alpha(S_\alpha) = 2$ and $\gamma(S_\alpha) = 0$ for any other simple root γ .

As mentioned in the introduction, if a Fourier coefficient $\mathcal{F}_{S,\varphi}$ is a Whittaker coefficient, i.e. $N_{S,\varphi}$ is the unipotent radical of a Borel subgroup, we will denote it by $\mathcal{W}_{S,\varphi}$, where we may drop the S if it corresponds to a fixed choice of Borel subgroup and simple roots. In other words, we define $S_\Pi \in \mathfrak{h}$ by $S_\Pi(\gamma) = 2$ for any simple root γ and write $\mathcal{W}_{S_\Pi,\varphi} = \mathcal{W}_\varphi$.

Lemma 3.1.1. *If η is a minimal automorphic function and $\varphi \in \mathfrak{g}_{-\alpha}^\times$ then $\mathcal{F}_{S_\alpha,\varphi}[\eta] = \mathcal{W}_\varphi[\eta]$.*

Proof. We have $\mathfrak{g}_1^S = \{0\} = \mathfrak{g}_{\geq 1}^{S_\alpha} \cap \mathfrak{g}_{< 1}^S$, which implies the lemma by Theorem 2.2.6 \square

Let L_α denote the Levi subgroup of the parabolic subgroup P_α of G .

Lemma 3.1.2. *Any root δ with $\delta(S_\alpha) = -2$ can be conjugated to $-\alpha$ using the Weyl group of L_α .*

Proof. We can assume that \mathfrak{g} is simple. This statement can be proved using the language of minuscule representations, i.e., representations such that the Weyl group has a single orbit on the weights of the representation. By [Bou75, §VIII.3] these are the fundamental representations corresponding to the abelian roots (see Table 1).

It suffices to show that the representation of the Levi L_α on the first internal Chevalley module $V_\alpha := \mathfrak{u}_\alpha / [\mathfrak{u}_\alpha, \mathfrak{u}_\alpha]$ is minuscule. These modules are explicitly computed in [MS12, §5]; and this can be checked case-by-case. For completeness we give a conceptual argument.

We claim first that V_α is irreducible with lowest weight α . Evidently α is a weight of V_α with multiplicity one. Also any positive root β of L_α involves only simple roots different from α , and thus $\alpha - \beta$ is not a root. Hence α is a lowest weight of V_α . On the other hand, any weight of V_α is of the form $\alpha + \gamma$, where γ is a sum of positive roots from L_α . Thus α is the unique lowest weight of V_α .

The Dynkin diagram of L_α is obtained from that of G by removing α , and each component has exactly one simple root adjacent to α , which is easily checked to be an abelian root for the component. Thus the corresponding fundamental representations are minuscule, and thus so is their tensor product W_α . However, W_α has highest weight $-\alpha$, since $\langle -\alpha, \beta \rangle$

is 1 if β is adjacent to α and zero otherwise. It follows that $V_\alpha \simeq W_\alpha^*$, and hence V_α is minuscule. \square

Corollary 3.1.3. *Let R denote the set of minimal elements in $(\mathfrak{g}^*)_{-2}^{S_\alpha}$.*

- (i) $R = (L_\alpha \cap \Gamma)(\mathfrak{g}_{-\alpha}^\times)$.
- (ii) $R \cap (\mathfrak{g}_{-\alpha}^\times + \bigoplus_{\varepsilon \in \Psi_\alpha} \mathfrak{g}_{-\varepsilon}^*) = \mathfrak{g}_{-\alpha}^\times$, where

$$\Psi_\alpha := \{ \text{root } \varepsilon \mid \langle \varepsilon, \alpha \rangle \leq 0, \varepsilon(S_\alpha) = 2 \}. \quad (3.3)$$

Proof. (i) Let z be a generic element of \mathfrak{h} that is 0 on α and negative on other positive roots. Decompose $(\mathfrak{g}^*)_{-2}^{S_\alpha} = \bigoplus_{i=0}^k V_k$ by eigenvectors of z , with eigenvalues $0 = t_0 < t_1 < \dots < t_k$. Note that $V_0 = \mathfrak{g}_{-\alpha}^*$. Let $X \in (\mathfrak{g}^*)_{-2}^{S_\alpha}$ be a minimal element and $X = \sum_i X_i$ its decomposition by eigenvalues of z . By Lemma 3.1.2 we can assume, by replacing X by its $L_\alpha \cap \Gamma$ -conjugate, that $X_0 \neq 0$. By Lemma 2.2.8, X is conjugate to X_0 using $\text{Exp}((\mathfrak{l}_\alpha)_{>0}^z) \subset L_\alpha \cap \Gamma$.

(ii) Let $Y = Y' + Y'' \in R$, where $Y' \in \mathfrak{g}_{-\alpha}^\times$ and $Y'' \in \bigoplus_{\varepsilon \in \Psi_\alpha} \mathfrak{g}_{-\varepsilon}^*$. Identify Y' with some $f \in \mathfrak{g}_{-\alpha}$ using the Killing form, and complete f to an \mathfrak{sl}_2 -triple e, h, f with $e \in \mathfrak{g}_\alpha$. Then $Y'' \in (\mathfrak{g}^*)^e$, since for every root $\varepsilon \in \Psi_\alpha$, $\alpha - \varepsilon$ is not a root. Thus Y belongs to the Slodowy slice $Y' + (\mathfrak{g}^*)^e$, that is transversal to the orbit of Y' . Since the orbit of Y is minimal, Y' must lie in the same orbit and thus $Y'' = 0$. \square

Lemma 3.1.4. *Let $\mathfrak{l} \subset \mathfrak{g}$ be a \mathbb{K} -Levi subalgebra, and let \mathcal{O} be the minimal nilpotent orbit in \mathfrak{g} . Then $\mathcal{O} \cap \mathfrak{l}$ is either empty or the minimal orbit of \mathfrak{l} .*

Proof. Suppose the contrary. Let $\mathcal{O}_\mathfrak{l}$ denote the minimal orbit of \mathfrak{l} . Then $\mathcal{O}_\mathfrak{l}$ lies in the Zariski closure of $\mathcal{O} \cap \mathfrak{l}$. Thus there exists an \mathfrak{sl}_2 triple (e, h, f) in \mathfrak{l} such that $f \in \mathcal{O}_\mathfrak{l}$, and the Slodowy slice $f + \mathfrak{l}^e$ to $\mathcal{O}_\mathfrak{l}$ at f intersects \mathcal{O} . Namely, there exists a non-zero $X \in \mathfrak{l}^e$ with $f + X \in \mathcal{O}$. This contradicts the minimality of \mathcal{O} , since $f + \mathfrak{l}^e$ is transversal to the orbit of f . \square

Proof of Theorem A. Part (iii) follows from Proposition 2.2.4 and the minimality of η .

Part (ii) follows from Corollary 3.1.3(i), and Lemmas 3.1.1 and 2.2.1.

For part (i), suppose that there exists a Whittaker pair (H, ψ) for L_α with $\psi \neq 0$ such that $\mathcal{F}_{H, \psi}[\mathcal{F}_{S_\alpha, 0}[\eta]] \neq 0$. Then, for T big enough, we have $\mathcal{F}_{H, \psi}[\mathcal{F}_{S_\alpha, 0}[\eta]] = \mathcal{F}_{H+TS_\alpha, \psi}[\eta]$. Thus, the orbit of ψ is minimal in \mathfrak{g}^* and thus, by Lemma 3.1.4 also in \mathfrak{l}_α^* . \square

3.2. Proof of Theorem B. Let η be a minimal automorphic function.

As above, for any simple root α let L_α be the Levi subgroup of P_α . Let $Q_\alpha \subset L_\alpha$ be the parabolic subgroup with Lie algebra $(\mathfrak{l}_\alpha)_{\leq 0}^{\alpha^\vee}$.

Lemma 3.2.1. *The stabilizer in L_α of the line $\mathfrak{g}_{-\alpha}^*$ as an element of the projective space of \mathfrak{g}^* is Q_α .*

Proof. For any root ε , $\varepsilon(\alpha^\vee) \leq 0$ if and only if $\varepsilon - \alpha$ is not a root. Thus the Lie algebra of the stabilizer of $\mathfrak{g}_{-\alpha}^*$ is the parabolic subalgebra $(\mathfrak{l}_\alpha)_{\leq 0}^{\alpha^\vee}$ of \mathfrak{l}_α . Thus the stabilizer is Q_α . \square

Let $\Gamma_\alpha := (L_\alpha \cap \Gamma)/(Q_\alpha \cap \Gamma)$.

Proposition 3.2.2. *Let α be a (simple) abelian root. Then*

$$\eta(g) = \mathcal{F}_{S_\alpha, 0}[\eta](g) + \sum_{\gamma \in \Gamma_\alpha} \sum_{\varphi \in \mathfrak{g}_{-\alpha}^\times} \mathcal{W}_\varphi[\eta](\gamma g). \quad (3.4)$$

Proof. By definition of an abelian root, the group U_α is abelian. Decompose η into Fourier series on U_α . The coefficients in the Fourier series will be given by $\mathcal{F}_{S_\alpha, \varphi'}[\eta]$ with $\varphi' \in (\mathfrak{g}^*)_{-2}^{S_\alpha}$. Note that this coefficient vanishes unless φ' is minimal or zero, and that by Corollary 3.1.3, all minimal $\varphi' \in (\mathfrak{g}^*)_{-2}^{S_\alpha}$ can be conjugated into $\mathfrak{g}_{-\alpha}^\times$ using $L_\alpha \cap \Gamma$. Thus we have

$$\eta(g) = \sum_{\varphi' \in (\mathfrak{g}^*)_{-2}^{S_\alpha}} \mathcal{F}_{S_\alpha, \varphi'}[\eta](g) = \mathcal{F}_{S_\alpha, 0}[\eta](g) + \sum_{\gamma \in \Gamma_\alpha} \sum_{\varphi \in \mathfrak{g}_{-\alpha}^\times} \mathcal{F}_{S_\alpha, \varphi}[\eta](\gamma g). \quad (3.5)$$

Lemma 3.1.1 and the minimality of η imply that $\mathcal{F}_{S_\alpha, \varphi}[\eta](\gamma g) = \mathcal{W}_\varphi[\eta](\gamma g)$. \square

Proof of Theorem B. The proof is by induction on the rank of G , that we denote by n . The base case of rank 1 group is the classical Fourier series decomposition. For the induction step let us show that

$$\eta = \mathcal{F}_{S_{\beta_n}, 0}[\eta] + C_n[\eta] \quad (3.6)$$

For that purpose, assume first that the root $\alpha := \beta_n$ is abelian. By Proposition 3.2.2 we have

$$\eta(g) = \mathcal{F}_{S_\alpha, 0}[\eta](g) + \sum_{\gamma \in \Gamma_\alpha} \sum_{\varphi \in \mathfrak{g}_\alpha^\times} \mathcal{W}_\varphi[\eta](\gamma g) = \mathcal{F}_{S_\alpha, 0}[\eta](g) + A_n[\eta](g) = \mathcal{F}_{S_\alpha, 0}[\eta](g) + C_n[\eta](g). \quad (3.7)$$

If $\alpha := \beta_n$ is a Heisenberg root then by Proposition 2.2.7 we have

$$\begin{aligned} \eta(g) &= \sum_{\varphi \in (\mathfrak{g}^*)_{-2}^{S_\alpha}} \mathcal{F}_{S_\alpha, \varphi}[\eta](g) + \sum_{\varphi \in \mathfrak{g}_{-\alpha}^\times} \sum_{\omega \in \Omega_\alpha} \sum_{\psi \in \bigoplus_{\varepsilon \in \Psi_\alpha} \mathfrak{g}_{-\varepsilon}^*} \mathcal{F}_{S_\alpha, \varphi + \psi}[\eta](\omega \gamma_n g) \\ &= \mathcal{F}_{S_\alpha, 0}[\eta](g) + A_n[\eta](g) + B_n[\eta](g) = \mathcal{F}_{S_\alpha, 0}[\eta](g) + C_n[\eta](g). \end{aligned} \quad (3.8)$$

Formula (3.6) is now established. By Theorem A(i), $\mathcal{F}_{S_\alpha, 0}[\eta]$ is a minimal automorphic function on L_α . As before, let $S_\Pi \in \mathfrak{h}$ denote the element that is 2 on all positive roots. Note that for any $\varphi \in (\mathfrak{g}^*)_{-2}^{S_\Pi}$, we have $\mathcal{W}'_\varphi[\mathcal{F}_{S_\alpha, 0}[\eta]] = \mathcal{W}_\varphi[\eta]$ where the prime denotes a Whittaker coefficient with respect to L_α . This implies that $C'_i[\mathcal{F}_{S_\alpha, 0}[\eta]] = C_i$ for any $i < n$. From the induction hypothesis and (3.6) we obtain

$$\eta(g) = \mathcal{F}_{S_{\beta_n}, 0}[\eta] + C_n = \mathcal{W}_0[\eta](g) + \sum_{i=1}^{n-1} C_i + C_n = \mathcal{W}_0[\eta](g) + \sum_{i=1}^n C_i. \quad (3.9)$$

\square

3.3. Proof of Theorem C. Suppose that $\text{rk}(\mathfrak{g}) > 2$. Let η be a next-to-minimal automorphic function. Let α be a simple root and let $\psi \in \mathfrak{g}_{-\alpha}^\times$.

Lemma 3.3.1. *Let $\gamma \neq \alpha$ be a positive root, and let $\varphi' \in \mathfrak{g}_{-\gamma}^\times$. Let \mathcal{O} denote the orbit of $\psi + \varphi'$. Then \mathcal{O} is minimal if $\langle \alpha, \gamma \rangle > 0$, \mathcal{O} is next-to-minimal if $\langle \alpha, \gamma \rangle = 0$ and \mathcal{O} is neither minimal nor next-to-minimal if $\langle \alpha, \gamma \rangle < 0$.*

Proof. By Lemma 2.1.3 we can assume that $[\mathfrak{g}, \mathfrak{g}]$ is simple. Let $\mathfrak{h}' \subset \mathfrak{h}$ be the simultaneous kernel of α and γ , and let \mathfrak{l} be its centralizer in \mathfrak{g} . Then \mathfrak{h}' has codimension at most 2 in \mathfrak{h} , hence \mathfrak{l} is a Levi subalgebra of semisimple rank ≤ 2 whose roots include α and γ . Note that $\mathcal{O} \cap \mathfrak{l}$ is a principal nilpotent orbit in \mathfrak{l} . By a straightforward rank 2 calculation we see that \mathfrak{l} has type A_1 if $\langle \alpha, \gamma \rangle > 0$, type $A_1 \times A_1$ if $\langle \alpha, \gamma \rangle = 0$ and type A_2 if $\langle \alpha, \gamma \rangle < 0$. The lemma follows now from Lemma 2.1.1. \square

Notation 3.3.2. Denote by Δ_α the set of simple roots orthogonal to α . Define $S \in \mathfrak{h}$ to be 0 on any simple root $\varepsilon \in \Delta_\alpha$, and 2 on other simple roots.

Proposition 3.3.3. *We have $\mathcal{F}_{S_\alpha, \psi}[\eta] = \mathcal{F}_{S, \psi}[\eta]$ for any $\psi \in \mathfrak{g}_{-\alpha}^*$.*

Proof. Note that S_α dominates S , and that $\mathfrak{g}_1^{S_\alpha} = \mathfrak{g}_1^S = \mathfrak{g}_{>1}^{S_\alpha} \cap \mathfrak{g}_{<1}^S = \{0\}$. Thus the statement follows from Theorem 2.2.6. \square

Let $G' \subset G$ be the Levi subgroup given by Δ_α .

Proposition 3.3.4. *The restriction $\mathcal{F}_{S, \psi}[\eta]|_{G'}$ is a minimal or a trivial automorphic function on G' .*

For the proof we will need the following geometric lemma.

Lemma 3.3.5. *Let $\varphi' \in \mathfrak{g}^{'*}$ be nilpotent such that $\varphi' + \psi$ belongs to a next-to-minimal orbit in \mathfrak{g}^* . Then φ' belongs to the minimal orbit of $\mathfrak{g}^{'*}$.*

Proof. Clearly $\varphi' \neq 0$. If the orbit of φ' is not minimal then it belongs to the Slodowy slice of some element ψ' of the minimal orbit of $(\mathfrak{g}')^*$. Then $\varphi' + \psi'$ belongs to a next-to-minimal orbit of \mathfrak{g}^* , and $\varphi' + \psi$ belongs to the Slodowy slice of $\varphi' + \psi'$ and thus lies in an orbit that is higher than next-to-minimal. \square

Proof of Proposition 3.3.4. Let $Z := S - S_\alpha$. Note that Z vanishes on simple roots in Δ_α and on α and is 2 on other simple roots. Suppose that there exists a Whittaker pair (H, ψ') with $\psi' \neq 0$ such that $\mathcal{F}_{H, \psi'}[\mathcal{F}_{S, \psi}[\eta]] \neq 0$. Then, for T big enough, we have

$$\mathcal{F}_{H, \psi'}[\mathcal{F}_{S, \psi}[\eta]] = \mathcal{F}_{S+TZ+H, \psi+\psi'}[\eta].$$

By Proposition 2.2.4 and Lemma 3.3.5, ψ lies in the minimal orbit of $\mathfrak{g}^{'*}$. \square

Lemma 3.3.6 (See §3.4 below). *For any next-to-minimal element $\varphi \in (\mathfrak{g}^*)_{-2}^{S_\alpha}$, there exist $\gamma_0 \in L_\alpha \cap \Gamma$ and a positive root β orthogonal to α s.t. $\text{Ad}^*(\gamma_0)\varphi \in \mathfrak{g}_{-\alpha}^\times + \mathfrak{g}_{-\beta}^\times \subset \mathfrak{g}_{-\alpha}^* \oplus \mathfrak{g}_{-\beta}^*$.*

Remark 3.3.7. The above lemma only establishes that any next-to-minimal φ can be mapped to two orthogonal root spaces by $L_\alpha \cap \Gamma$. However, the action of $L_\alpha \cap \Gamma$ is often even transitive on $(\mathfrak{g}^*)_{-2}^{S_\alpha}$, giving a single orbit. One can show that this happens in all cases except for:

- A_3 and node α_2 .
- D_4 and nodes $\alpha_1, \alpha_3, \alpha_4$ (all related by triality).
- D_n and when the two orthogonal roots (α, β) are Weyl conjugate under D_n to (α_{n-1}, α_n) , see Corollary 3.0.3, corresponding to the orbit 31^{2n-3} . This happens for $n \geq 4$ always for node α_1 as well as for nodes α_i with $2 \leq i \leq n-2$ if φ belongs to that orbit.

For instance, for A_3 and node α_2 one has that next-to-minimal are $\varphi \in \mathfrak{g}_{-\alpha_1}^\times + \mathfrak{g}_{-\alpha_3}^\times$. The torus element for node i scales elements in $\mathfrak{g}_{-\alpha_i}^\times$ by rational squares ($i = 1, 3$) while keeping the other space unchanged. The torus element for node 2 scales both spaces by rational elements in the same way and so one cannot use the torus action in $L_{\alpha_2} \cap \Gamma$ to arrive at a unique representative. The other cases can be seen to reduce to the same phenomenon.

For A_n with $n \geq 4$ and all exceptional cases there is a unique rational representative for next-to-minimal nilpotents in $(\mathfrak{g}^*)_{-2}^{S_\alpha}$.

Proof of Theorem C. Part (iv) follows from Proposition 2.2.4, since η is a next-to-minimal function.

For part (iii), by Lemma 3.3.6 we may assume $\varphi \in \mathfrak{g}_{-\alpha}^\times + \mathfrak{g}_{-\beta}^\times$ for some positive roots β orthogonal to α . By Corollary 3.0.4, one can conjugate the pair of roots (α, β) to a pair of orthogonal simple roots (α', α'') , using the Weyl group. Let \mathfrak{a} be the joint kernel of α' and α'' in \mathfrak{h} , and let $z \in \mathfrak{a}$ be a generic rational semi-simple element. Let $S_T := \alpha'^\vee + \alpha''^\vee + Tz$ for $T \gg 0 \in \mathbb{Q}$, where α'^\vee and α''^\vee are the dual co-roots. Since no linear combination of α'^\vee and α''^\vee lies in \mathfrak{a} , S_T is a generic element of \mathfrak{a} and thus for T big enough, $\mathfrak{g}_{>2}^{S_T}$ is a Borel subalgebra of \mathfrak{g} that contains \mathfrak{h} . Thus it is conjugate under the Weyl group to our fixed Borel subalgebra. The statement follows now from Theorem 2.2.6. We note that different choices for z may give V of different dimensions.

For part (ii), Proposition 3.3.3 implies $\mathcal{F}_{S_\alpha, \psi}[\eta] = \mathcal{F}_{S, \psi}[\eta]$. By Proposition 3.3.4, $\eta' := \mathcal{F}_{S, \psi}[\eta]|_{G'}$ is a minimal or a trivial automorphic function on G' . The statement follows now from Theorem B applied to η' together with the fact that its Whittaker coefficients, obtained by integration over the maximal unipotent subgroup $N' = N \cap G'$, are, in fact, equal to the Whittaker coefficients $\mathcal{W}_{\varphi+\psi}[\eta]$ due to the extra integral present in the definition of η' .

Part (i) is proven very similarly to Theorem A(i). □

3.4. Proof of Lemma 3.3.6. Let α be a simple root. We assume that \mathfrak{g} is simple.

Note that in simply-laced root systems orthogonal roots are strongly orthogonal, and thus the sum of two roots is a root if and only if they have scalar product -1 . Also, for any two non-proportional roots, the scalar product is in $\{-1, 0, 1\}$. For any root ε we denote by ε^\vee the coroot given by the scalar product with ε .

Notation 3.4.1. Denote $z := \alpha^\vee - S_\alpha$ and $\mathfrak{u}_z := (\mathfrak{t}_\alpha)_{>0}^z$, and $U_z := \text{Exp}(\mathfrak{u}_z) \subset L_\alpha \cap \Gamma$.

Note that $\mathfrak{u}_z = (\mathfrak{t}_\alpha)_1^{\alpha^\vee}$ and $\mathfrak{g}_{-\alpha}^\times \subset (\mathfrak{g}^*)_0^z$.

Lemma 3.4.2. *Let $\varphi \in \mathfrak{g}_{-\alpha}^\times$ and $\psi \in (\mathfrak{g}^*)_{-2}^{S_\alpha} \cap (\mathfrak{g}^*)_{-1}^{\alpha^\vee} \subset (\mathfrak{g}^*)_1^z$. Then there exists $v \in U_z$ such that $\text{Ad}^*(v)\varphi = \varphi + \psi$.*

Proof. Case 1. $\psi \in \mathfrak{g}_{-\varepsilon}^*$ for some ε :

By the assumption that $\psi \in (\mathfrak{g}^*)_{-1}^{\alpha^\vee}$ and Lemma 3.3.1, $\varphi + \psi$ is conjugate to φ over \mathbb{C} . By Lemma 2.2.8, there exists $v \in U_z$ such that $\text{Ad}^*(v)\varphi = \varphi + \psi$.

Case 2. General:

We can assume $\psi \neq 0$. Let $H \in \mathfrak{h}$ be a generic element that has distinct negative integer values on all positive roots. Note that $\mathfrak{u}_z \subset \mathfrak{g}_{>0}^H$ and $\psi \in (\mathfrak{g}^*)_{>0}^H$. Decompose $\psi = \sum_{i>0} \psi_i$, where $\psi_i \in (\mathfrak{g}^*)_i^H$. We prove the lemma by descending induction on

the minimal j for which $\psi_j \neq 0$. The base of the induction is j that equals the maximal eigenvalue of $\text{ad}^*(H)$. In this case $\psi = \psi_j$ and we are in Case 1. For the induction step, let j be minimal with $\psi_j \neq 0$. By Case 1, there exists $v_1 \in U_z$ with $\text{Ad}^*(v_1)\varphi = \varphi - \psi_j$. Then $\text{Ad}^*(v_1)(\varphi + \psi) = \varphi + \sum_{i>j} \psi'_i$, for some $\psi'_i \in (\mathfrak{g}^*)_i^H$. By the induction hypothesis, there exists $v_2 \in U_z$ such that $\text{Ad}^*(v_2)\varphi = \text{Ad}^*(v_1)(\varphi + \psi)$. Take $v := v_1^{-1}v_2$. □

Proof of Lemma 3.3.6. Let $\varphi \in (\mathfrak{g}^*)_{-2}^{S_\alpha}$ be next-to-minimal. Decompose $\varphi = \sum_\varepsilon \varphi_\varepsilon$, where $\varphi_\varepsilon \in \mathfrak{g}_{-\varepsilon}^*$. Let $F := \{\varepsilon \mid \varphi_\varepsilon \neq 0\}$. By Lemma 3.1.2, we can assume $\alpha \in F$. Using Lemma 3.4.2, we can assume that for any other $\varepsilon \in F$ we have $\langle \alpha, \varepsilon \rangle \leq 0$, i.e. $F \subset \{\alpha\} \cup \Psi_\alpha$, where Ψ_α is as in (3.3), namely

$$\Psi_\alpha = \{ \text{root } \varepsilon \mid \langle \varepsilon, \alpha \rangle \leq 0, \varepsilon(S_\alpha) = 2 \}. \quad (3.10)$$

Assume first that there exists $\beta \in F$ with $(\alpha, \beta) = 0$, and let $Z := \alpha^\vee + \beta^\vee - S_\alpha$. Then

$$\alpha(Z) = \beta(Z) = 0, \text{ and } \varepsilon(Z) < 0 \text{ for any } \varepsilon \in F \setminus \{\alpha, \beta\}. \quad (3.11)$$

Indeed,

$$\varepsilon(Z) = \langle \alpha, \varepsilon \rangle + \langle \beta, \varepsilon \rangle - 2 \leq 0 + 1 - 2 = -1.$$

By (3.11), we see that $\varphi_\alpha + \varphi_\beta$ lies in the closure of the complex orbit \mathcal{O} of φ . Now, by Lemma 3.3.1, $\varphi_\alpha + \varphi_\beta$ is next-to-minimal, and thus lies in \mathcal{O} . Thus, Lemma 2.2.8 and (3.11) imply that φ is conjugate to $\varphi_\alpha + \varphi_\beta$ under $L_\alpha \cap \Gamma$.

Let us now show that $\beta \in F$ with $\langle \alpha, \beta \rangle = 0$ indeed exists. Assume the contrary, i.e. $(\alpha, \varepsilon) = -1$ for all $\varepsilon \in F$. Note that F is not empty, since φ is not minimal. Pick any $\omega \in F$ and let $Z' := \alpha^\vee + \omega^\vee - S_\alpha/2$. Then

$$\alpha(Z') = \omega(Z') = 0, \text{ and } \varepsilon(Z') < 0 \text{ for any } \varepsilon \in F \setminus \{\alpha, \omega\}. \quad (3.12)$$

Indeed,

$$\varepsilon(Z') = \langle \alpha, \varepsilon \rangle + \langle \omega, \varepsilon \rangle - 1 \leq -1 + 1 - 1 = -1.$$

By (3.11), we see that $\varphi_\alpha + \varphi_\omega$ lies in the closure of the complex orbit \mathcal{O} of φ , and thus is minimal or next-to-minimal. This contradicts Lemma 3.3.1 since $\langle \alpha, \omega \rangle < 0$.

Thus there exists $\beta \in F$ with $\langle \alpha, \beta \rangle = 0$, and as we showed above φ is conjugate to $\varphi_\alpha + \varphi_\beta$ under $L_\alpha \cap \Gamma$. □

4. PROOF OF THEOREMS D, E, F AND G

Let α be a nice root. Denote by R the set of minimal elements in $(\mathfrak{g}^*)_{-2}^{S_\alpha}$ and by X the set of next-to-minimal elements in $(\mathfrak{g}^*)_{-2}^{S_\alpha}$. Let α_{\max} be the highest root of the component of \mathfrak{g} that includes α . Recall that δ_α denotes α_{\max} if α is an abelian root, and denotes $\alpha_{\max} - \alpha - \beta$, where β is the only simple root non-orthogonal to α , if α is a nice Heisenberg root. Denote $\delta := \delta_\alpha$. See §4.3 below for more details on this δ in the Heisenberg case.

We will use the following geometric propositions, that we will prove in §4.3 below.

Proposition 4.0.1. (i) *If α is abelian and $\langle \alpha, \alpha_{\max} \rangle > 0$ then X is empty.*
(ii) *If $\langle \alpha, \alpha_{\max} \rangle = 0$ or if α is a nice Heisenberg root then $X = (L_\alpha \cap \Gamma)(\mathfrak{g}_{-\alpha}^\times + \mathfrak{g}_{-\delta}^\times)$.*

Note that this implies that at most one next-to-minimal orbit can intersect X .

For the next proposition we assume that either $\langle \alpha, \alpha_{\max} \rangle = 0$ or α is a nice Heisenberg root. Recall that in these cases R_α denotes the parabolic subgroup of L_α with Lie algebra $(\mathfrak{l}_\alpha)_{\leq 0}^\delta$, and let $RQ_\alpha = R_\alpha \cap Q_\alpha$. Denote further by St_α the stabilizer in $L_\alpha \cap \Gamma$ of the plane $\mathfrak{g}_{-\alpha}^* \oplus \mathfrak{g}_{-\delta}^*$, as an element of the Grassmanian of planes in \mathfrak{g}^* .

Proposition 4.0.2. *$RQ_\alpha \cap \Gamma$ is a subgroup of St_α of index two.*

4.1. **Proof of Theorem D.** Let η be a next-to-minimal automorphic function on G .

Suppose first that α is an abelian root, *i.e.* the nilradical U_α of the maximal parabolic P_α is abelian. Using Fourier transform on U_α we obtain

$$\eta(g) = \mathcal{F}_{S_\alpha, 0}[\eta](g) + \sum_{\varphi \in R} \mathcal{F}_{S_\alpha, \varphi}[\eta](g) + \sum_{\varphi \in X} \mathcal{F}_{S_\alpha, \varphi}[\eta](g). \quad (4.1)$$

By Corollary 3.1.3, $R = (L_\alpha \cap \Gamma)(\mathfrak{g}_{-\alpha}^\times)$. By Lemma 3.2.1, Q_α is the stabilizer in L_α of the line $\mathfrak{g}_{-\alpha}^*$ (as a point in the projective space of \mathfrak{g}^*). Thus

$$\sum_{\varphi \in R} \mathcal{F}_{S_\alpha, \varphi}[\eta](g) = \sum_{\gamma \in \Gamma_\alpha} \sum_{\varphi_0 \in \mathfrak{g}_{-\alpha}^\times} \mathcal{F}_{S_\alpha, \varphi_0}[\eta](\gamma g), \quad (4.2)$$

where Γ_α denotes the quotient of $L_\alpha \cap \Gamma$ by $Q_\alpha \cap \Gamma$. If $\langle \alpha, \alpha_{\max} \rangle > 0$ then by Proposition 4.0.1, X is empty. This implies part (i) of Theorem D. Let us now assume $\langle \alpha, \alpha_{\max} \rangle = 0$ and prove part (ii) of Theorem D. By Proposition 4.0.1, $X = (L_\alpha \cap \Gamma)(\mathfrak{g}_{-\alpha}^\times + \mathfrak{g}_{-\delta}^\times)$. Recall that we denote by Λ_α the quotient of $L_\alpha \cap \Gamma$ by $RQ_\alpha \cap \Gamma$. By Proposition 4.0.2 we have

$$\sum_{\varphi \in X} \mathcal{F}_{S_\alpha, \varphi}[\eta](g) = \frac{1}{2} \sum_{\gamma \in \Lambda_\alpha} \sum_{\varphi \in \mathfrak{g}_{-\alpha}^\times} \sum_{\psi \in \mathfrak{g}_{-\alpha_{\max}}^\times} \mathcal{F}_{S_\alpha, \varphi + \psi}[\eta](\gamma g). \quad (4.3)$$

From (4.1), (4.2) and (4.3), we obtain

$$\eta(g) = \mathcal{F}_{S_\alpha, 0}[\eta] + \sum_{\gamma \in \Gamma_\alpha} \sum_{\varphi \in \mathfrak{g}_{-\alpha}^\times} \mathcal{F}_{S_\alpha, \varphi}[\eta](\gamma g) + \frac{1}{2} \sum_{\gamma \in \Lambda_\alpha} \sum_{\varphi \in \mathfrak{g}_{-\alpha}^\times} \sum_{\psi \in \mathfrak{g}_{-\alpha_{\max}}^\times} \mathcal{F}_{S_\alpha, \varphi + \psi}[\eta](\gamma g) = \mathcal{A}, \quad (4.4)$$

as required.

Suppose now that α is a nice Heisenberg root. Let γ_α be a representative of the Weyl group element $s_\alpha s_{\alpha_{\max}} s_\alpha$, where s_α and $s_{\alpha_{\max}}$ denote the corresponding reflections. Since $\langle \alpha, \alpha_{\max} \rangle = 1$, γ_α conjugates α to α_{\max} . Thus, by Proposition 2.2.7,

$$\eta(g) = \sum_{\varphi \in (\mathfrak{g}^*)_{-2}^{S_\alpha}} \mathcal{F}_{S_\alpha, \varphi}[\eta](g) + \sum_{\varphi \in \mathfrak{g}_{-\alpha}^\times} \sum_{\omega \in \Omega_\alpha} \sum_{\psi \in \bigoplus_{\varepsilon \in \Psi_\alpha} \mathfrak{g}_{-\varepsilon}^*} \mathcal{F}_{S_\alpha, \varphi + \psi}[\eta](\omega \gamma_\alpha g). \quad (4.5)$$

We call the first sum the *abelian* term, and the second sum the *non-abelian* term. In the same way as above we obtain

$$\sum_{\varphi \in (\mathfrak{g}^*)_{-2}^{S_\alpha}} \mathcal{F}_{S_\alpha, \varphi}[\eta](g) = \mathcal{A} \quad (4.6)$$

To determine the non-abelian term we will need a further geometric statement. Recall that $M_\alpha \subset L_\alpha$ denotes the Levi subgroup generated by the roots orthogonal to α . Note that M_α is the standard Levi subgroup of the parabolic Q_α of L_α .

Lemma 4.1.1. *The group $M_\alpha \cap R_\alpha \cap \Gamma$ is the stabilizer in $M \cap \Gamma$ of the line $\mathfrak{g}_{-\delta}^*$, and of the plane $\mathfrak{g}_{-\alpha}^* \oplus \mathfrak{g}_{-\delta}^*$.*

Proof. The first assertion follows from Lemma 3.2.1 applied to the root δ . The second one follows from Proposition 4.0.2, since $M_\alpha \cap R_\alpha$ is a parabolic subgroup of M_α . \square

Denote by \mathfrak{X} the set of next-to-minimal elements in $\mathfrak{g}_{-\alpha}^\times + \bigoplus_{\varepsilon \in \Psi_\alpha} \mathfrak{g}_{-\varepsilon}^*$.

Proposition 4.1.2 (See §4.3 below). $\mathfrak{X} = (M_\alpha \cap \Gamma)(\mathfrak{g}_{-\alpha}^\times + \mathfrak{g}_{-\delta}^\times)$.

Recall that \mathcal{M}_α denotes the quotient of $M_\alpha \cap \Gamma$ by $M_\alpha \cap R_\alpha \cap \Gamma$. By Theorem C(iv), Proposition 4.1.2, Lemma 4.1.1 and Corollary 3.1.3(ii) we have, for any $\omega \in \Omega_\alpha$,

$$\begin{aligned} \sum_{\varphi \in \mathfrak{g}_{-\alpha}^\times} \sum_{\psi \in \bigoplus_{\varepsilon \in \Psi_\alpha} \mathfrak{g}_{-\varepsilon}^*} \mathcal{F}_{S_\alpha, \varphi + \psi}[\eta](\omega sg) = \\ \sum_{\varphi \in \mathfrak{g}_{-\alpha}^\times} \mathcal{F}_{S_\alpha, \varphi}[\eta](\omega sg) + \sum_{\gamma' \in \mathcal{M}_\alpha} \sum_{\varphi \in \mathfrak{g}_{-\alpha}^\times} \sum_{\psi \in \mathfrak{g}_{-\delta}^\times} \mathcal{F}_{S_\alpha, \varphi + \psi}[\eta](\gamma' \omega \gamma_\alpha g). \end{aligned} \quad (4.7)$$

From (4.5), (4.6) and (4.7), we obtain

$$\eta(g) = \mathcal{A} + \sum_{\omega \in \Omega_\alpha} \left(\sum_{\varphi \in \mathfrak{g}_{-\alpha}^\times} \mathcal{F}_{S_\alpha, \psi}[\eta](\omega \gamma_\alpha g) + \sum_{\gamma' \in \mathcal{M}_\alpha} \sum_{\varphi \in \mathfrak{g}_{-\alpha}^\times} \sum_{\psi \in \mathfrak{g}_{-\delta}^\times} \mathcal{F}_{S_\alpha, \varphi + \psi}[\eta](\gamma' \omega \gamma_\alpha g) \right), \quad (4.8)$$

as required. \square

4.2. Proof of Theorems E, F and G.

Proof of Theorem E. We proceed by induction on the rank of \mathfrak{g} . The base case is rank one, that has no next-to-minimal forms, and the statement vacuously holds. For the induction step, let η be a next-to-minimal automorphic function. Let $I = \{\beta_1, \dots, \beta_n\}$ be a convenient quasi-abelian enumeration of the roots of \mathfrak{g} . Denote $\alpha := \beta_n$. Theorem C provides the expressions for all the terms in the right-hand side of the expressions in Theorem D, except the constant term. By Theorem C(i), the restriction of the constant term $\mathcal{F}_{S_\alpha, 0}[\eta](g)$ to the Levi subgroup L_α is next-to-minimal or minimal or trivial. Thus, we can obtain the expressions for the constant term by Theorem B and the induction hypothesis. Applying

Theorem C(ii) to $\mathcal{F}_{S_{\alpha},\varphi}$ for any $\varphi \in \mathfrak{g}_{-\alpha}^{\times}$, we get, in the notation of Theorem C, $\gamma_0 = 1$, $\psi = \varphi$, $C_j^{\psi}[\eta] = A_j^{\varphi}[\eta]$ for all $1 \leq j \leq n-1$, and

$$\mathcal{F}_{S_{\alpha},\varphi}[\eta](\gamma g) = \mathcal{W}_{\varphi}[\eta](\gamma g) + \sum_{j=1}^{n-1} A_j^{\varphi}[\eta](\gamma g). \quad (4.9)$$

Thus

$$\sum_{\gamma \in \Gamma_n} \sum_{\varphi \in \mathfrak{g}_{-\alpha}^{\times}} \mathcal{F}_{S_{\alpha},\varphi}[\eta](\gamma g) = A_n + \sum_{j \perp n} A_{nj}. \quad (4.10)$$

Further, for any $\varphi \in \mathfrak{g}_{-\alpha}^{\times}$ and $\psi \in \mathfrak{g}_{-\alpha_{\max}}^{\times}$, Theorem C(iii) provides an expression for $\mathcal{F}_{\varphi+\psi}[\eta]$. This expression implies

$$\sum_{\gamma \in \Lambda_{\alpha}} \sum_{\varphi \in \mathfrak{g}_{-\alpha}^{\times}} \sum_{\psi \in \mathfrak{g}_{-\alpha_{\max}}^{\times}} \mathcal{F}_{\varphi+\psi}[\eta](\gamma g) = A_{nn}. \quad (4.11)$$

Assume first that $\alpha := \beta_n$ is an abelian root. Then, using Theorem D, (4.10), (4.11) and the induction hypothesis, we obtain

$$\eta = \mathcal{F}_{S_{\alpha},0}[\eta] + A_n + \sum_{j \perp n} A_{nj} + A_{nn} = \mathcal{W}_0[\eta] + \sum_{i=1}^n (A_i + A_{ii} + \sum_{j < i, j \perp i} A_{ij}), \quad (4.12)$$

as required.

Suppose now that α is a nice Heisenberg root. Then we need to add the expressions for the non-abelian term in (4.8). These are also provided by Theorem C. Namely,

$$\sum_{\omega \in \Omega_n} \sum_{\varphi \in \mathfrak{g}_{-\alpha}^{\times}} \mathcal{F}_{S_{\alpha},\psi}[\eta](\omega \gamma_n g) = B_n + \sum_{j \perp n} B_{nj}, \quad (4.13)$$

$$\sum_{\omega \in \Omega_n} \sum_{\gamma' \in \mathcal{M}_{\alpha}} \sum_{\varphi \in \mathfrak{g}_{-\alpha}^{\times}} \sum_{\psi \in \mathfrak{g}_{-\delta_{\alpha}}^{\times}} \mathcal{F}_{S_{\alpha},\varphi+\psi}[\eta](\gamma' \omega \gamma_n g) = B_{nn}. \quad (4.14)$$

The theorem follows now from Theorem D, and (4.10)–(4.14). \square

Theorem F follows in a similar way, but without using the induction, and omitting some terms that vanish.

Proof of Theorem G. Suppose the contrary. Embed π into the cuspidal spectrum and let $\eta \neq 0 \in \pi$. By Lemma 2.0.7, η is either minimal or next-to-minimal. If \mathfrak{g} has a component of type E_8 we let $G' \subset G$ be the subgroup corresponding to this component. Otherwise we let $G' := G$. Let η' be the restriction of η to G' . Note that η' is still minimal or next-to-minimal, and that it is cuspidal in the sense that the constant term of η' with respect to the unipotent radical of any proper parabolic subgroup of G' vanishes. Thus, for any two simple roots $\varepsilon_1, \varepsilon_2$ and any $\varphi \in \mathfrak{g}_{\varepsilon_1}^* \oplus \mathfrak{g}_{\varepsilon_2}^*$, the Whittaker coefficient $\mathcal{W}_{\varphi}[\eta']$ vanishes identically. Since all the terms in the right-hand sides of Theorems B and E is obtained from such Whittaker coefficients by summation, integration, and shift of the argument, we obtain from those theorems that η' vanishes identically. This implies $\eta(1) = 0$. Replacing η in the argument above by its right shifts, we obtain $\pi = 0$, reaching a contradiction. \square

4.3. Proof of geometric propositions. In this subsection we assume that \mathfrak{g} is simple, since for Propositions 4.0.1, 4.0.2, and 4.1.2 it is enough to consider this case.

4.3.1. *Proof of Proposition 4.0.2.*

Lemma 4.3.1. *There exists w in the Weyl group of L_α such that $w^2 = 1$ and $w(\alpha) = \delta_\alpha$.*

Proof. We can assume that \mathfrak{g} is simple. If α is abelian, we take w to be w_0 , where w_0 is the longest element in the Weyl group of L_α . Since α is the lowest weight of the first internal Chevalley L_α -module \mathfrak{n}_α , and $\delta_\alpha = \alpha_{\max}$ is its highest weight, $w_0(\alpha) = \delta_\alpha$.

If α is Heisenberg, we take w to be $s_\beta w_0$, where β is the only root attached to α . In this case, the highest weight of \mathfrak{n}_α is $\alpha_{\max} - \alpha$, while the lowest weight is still α . Thus, $w_0(\alpha) = \alpha_{\max} - \alpha$. Since α is a Heisenberg root, β is orthogonal to α_{\max} . Thus, $s_\beta(\alpha_{\max} - \alpha) = \alpha_{\max} - \alpha - \langle \alpha_{\max} - \alpha, \beta \rangle \beta = \alpha_{\max} - \alpha - \beta = \delta_\alpha$. To prove that w is an involution, we will show that $w_0(\beta) = -1$. To see this, we apply the well known fact that $-w_0$ is a graph automorphism of the Dynkin diagram. For \mathfrak{g} of type E_8 , we have $\alpha = \alpha_8$, L_α is of type E_7 , and the Dynkin diagram has no automorphisms. For \mathfrak{g} of type E_7 , we have $\alpha = \alpha_1$, L_α is of type D_6 , and w_0 is known to be -1 . In the remaining case of \mathfrak{g} of type E_6 , we have $\alpha = \alpha_2$, $\beta = \alpha_4$, L_α is of type A_5 , and $-w_0$ induces the non-trivial graph automorphism, which however fixes β . □

Proof of Proposition 4.0.2. We first note that St_α preserves the union of coordinate axis in $\mathfrak{g}_{-\alpha}^* \oplus \mathfrak{g}_{-\delta}^*$, since this union is also the union of $\{0\}$ with the set of minimal elements in $\mathfrak{g}_{-\alpha}^* \oplus \mathfrak{g}_{-\delta}^*$. Since the action of St_α on $\mathfrak{g}_{-\alpha}^* \oplus \mathfrak{g}_{-\delta}^*$ is linear, any $g \in St_\alpha$ either preserves the line $\mathfrak{g}_{-\alpha}^*$ or sends all its elements to elements of $\mathfrak{g}_{-\delta}^*$. Thus, by Lemma 4.3.1, exactly one of the elements $\{g, w_0 g\}$ preserves both lines $\mathfrak{g}_{-\alpha}^*$ and $\mathfrak{g}_{-\delta}^*$. By Lemma 3.2.1, $Q_\alpha \cap \Gamma$ is the stabilizer of the line $\mathfrak{g}_{-\alpha}^*$. By the same lemma applied to δ , $R_\alpha \cap \Gamma$ is the stabilizer of the line $\mathfrak{g}_{-\delta}^*$. Thus, $RQ_\alpha \cap \Gamma$ is the joint stabilizer of both lines, and has index two in St_α . □

4.3.2. *Preparation lemma.* Assume \mathfrak{g} is not of type A_n , and let α be a quasi-abelian root. If \mathfrak{g} is of type D_n we assume further that α is an abelian root. By Table 1, these assumptions imply that α corresponds to an extreme node in the Dynkin diagram, *i.e.* there exists a unique simple root β not orthogonal to α . Thus $M_\alpha = L_\alpha \cap L_\beta$. Denote

$$\Phi_\alpha := \{ \text{root } \varepsilon \mid \langle \varepsilon, \alpha \rangle = 0, \varepsilon(S_\alpha) = 2 \}. \quad (4.15)$$

Lemma 4.3.2. *The Weyl group of M_α acts transitively on Φ_α .*

Proof. Note that for any root ε , $\langle \alpha, \varepsilon \rangle = \varepsilon(S_\alpha) - \varepsilon(S_\beta)/2$. Thus $\varepsilon \in \Phi_\alpha$ if and only if $\varepsilon(S_\beta) = 4$. In other words, Φ_α is the set of roots of the L_β -module $\mathfrak{g}_4^{S_\beta}$, described in [MS12, §5] where it is called the second internal Chevalley module. The second Chevalley module for the node β is given by all roots of \mathfrak{g} with coefficient 2 along β . This can never happen for \mathfrak{g} of type A , so the second Chevalley module is trivial. For types D and E , and α an extreme node of the Dynkin diagram, not necessarily nice, the second Chevalley module for the adjacent L_β is irreducible [MS12]. This irreducible representation can be found uniformly by finding the lowest root θ of \mathfrak{g} with coefficient 2 along β . This root θ is equal to the highest root of the smallest D -type diagram that can be embedded in the diagram

of \mathfrak{g} such that β is the second node (in Bourbaki enumeration) of that D -type diagram. With this characterization θ is zero on torus elements γ^\vee for all simple roots different from β and the set of nodes I directly attaching to the embedded D -type diagram. The root θ is -1 on the generators α_i^\vee ($i \in I$), thus making the restriction of θ a lowest weight of M_β . In particular, θ is trivial on α^\vee and by inspection one finds the following modules π of M_α when α is nice.

Case D_n , $\alpha = \alpha_1$, $\beta = \alpha_2$, $I = \emptyset$, $\pi=1$ -dimensional representation of $M_\alpha \cong D_{n-2}$.

Case D_n , $\alpha = \alpha_{n-1}$ (or $\alpha = \alpha_n$), $\beta = \alpha_{n-2}$, $I = \{n-4\}$, π =exterior square of the standard representation of $M_\alpha \cong A_{n-3}$.

Case E_6 , $\alpha = \alpha_2$, $\beta = \alpha_4$, $I = \{1, 6\}$, π =tensor product of the vector representation with the contragredient vector representation of $M_\alpha \cong A_2 \times A_2$.

Case E_6 , $\alpha = \alpha_1$ (α_6), $\beta = \alpha_3$ (α_5), $I = \{6\}$ ($\{1\}$), π =the standard representation of $M_{\alpha_1} \cong A_4$ ($M_{\alpha_6} \cong A_4$).

Case E_7 , $\alpha = \alpha_1$, $\beta = \alpha_3$, $I = \{6\}$, π =the exterior square of $M_\alpha \cong A_5$.

Case E_7 , $\alpha = \alpha_7$, $\beta = \alpha_6$, $I = \{1\}$, π =standard representation of $M_\alpha \cong D_5$.

Case E_8 : $\alpha = \alpha_8$, $\beta = \alpha_7$, $I = \{1\}$, $\pi=27$ -dimensional representation of $M_\alpha \cong E_6$.

All the modules listed are minuscule by [Bou75, §VIII.3]. \square

4.3.3. *Proof of Proposition 4.0.1.* Let α be a nice root, *i.e.* an abelian root for any \mathfrak{g} , or a Heisenberg root in types E_6, E_7, E_8 . Let X denote the set of next-to-minimal elements in $(\mathfrak{g}^*)_{-2}^{S_\alpha}$.

Lemma 4.3.3. *Assume \mathfrak{g} is of type A_n , and $\alpha = \alpha_k$ in the Bourbaki enumeration with $k \notin \{1, n\}$. Then the stabilizer of α in the Weyl group of L_α acts transitively on Φ_α .*

Proof. In the ε notation we have $\alpha = \varepsilon_k - \varepsilon_{k+1}$, and Φ_α consists of all the roots $\varepsilon_i - \varepsilon_j$ with $i < k < k+1 < j$. The stabilizer of α in the Weyl group of L_α permutes all $i < k$ and all $j > k+1$ independently. \square

Proof of Proposition 4.0.1. (i) If α is abelian and $\langle \alpha, \alpha_{\max} \rangle > 0$, then \mathfrak{g} is of type A_n , and α is either α_1 or α_n in the Bourbaki enumeration. In both cases, $(\mathfrak{g}^*)_{-2}^{S_\alpha} \setminus \{0\}$ is given by trace pairing with rank one matrices, and thus has only minimal orbit and $X = \emptyset$.

(ii) We have $\delta \in \Phi_\alpha$ and Lemma 3.3.1 implies that X is non-empty. Further, by Lemma 3.3.6, any $\varphi \in X$ can be conjugated by $L_\alpha \cap \Gamma$ into $\mathfrak{g}_{-\alpha}^\times + \mathfrak{g}_{-\omega}^\times$ for some $\omega \in \Phi_\alpha$. By Lemmas 4.3.2 and 4.3.3, we can assume $\omega = \delta$. \square

4.3.4. *Proof of Proposition 4.1.2.* By the assumption of the proposition, α is a nice Heisenberg root. In other words, α is a Heisenberg root, and \mathfrak{g} is of type E_n for $n \in \{6, 7, 8\}$. Recall that

$$\Psi_\alpha = \{ \text{root } \varepsilon \mid \langle \varepsilon, \alpha \rangle \leq 0, \varepsilon(S_\alpha) = 2 \}. \quad (4.16)$$

and that \mathfrak{X} denotes the set of next-to-minimal elements in $\mathfrak{g}_{-\alpha}^\times + \bigoplus_{\varepsilon \in \Psi_\alpha} \mathfrak{g}_{-\varepsilon}^*$. Let α_{\max} denote the maximal root of \mathfrak{g} . Since α is a Heisenberg root, $\langle \alpha, \alpha_{\max} \rangle = 1$ and thus $\gamma := \alpha_{\max} - \alpha$ is a root.

Lemma 4.3.4. (i) $\Psi_\alpha = \Phi_\alpha \cup \{\gamma\}$.

(ii) For any $\varepsilon \in \Psi_\alpha$, $\varepsilon - \alpha$ is not a root.

Proof. (i) For any $\varepsilon \in \Psi_\alpha \setminus \Phi_\alpha$, $\alpha + \varepsilon$ is a root and $(\alpha + \varepsilon)(S_\alpha) = 4$. Since α is a Heisenberg root, this implies $\alpha + \varepsilon = \alpha_{\max}$.

(ii) $\langle \varepsilon, -\alpha \rangle \geq 0$ by definition of Ψ_α . \square

As in §4.3.2, let β be the unique simple root not orthogonal to α . Note that $\langle \beta, \gamma \rangle = -\langle \beta, \alpha \rangle = 1$ and thus $\delta := \gamma - \beta$ is a root.

Lemma 4.3.5. *Let λ be a root with $\lambda(S_\alpha) = 0$. Then*

(i) $\langle \lambda, \alpha \rangle \cdot \langle \lambda, \beta \rangle \leq 0$.

(ii) If $\langle \lambda, \alpha \rangle \neq 0$ and $\delta + \lambda \in \Psi_\alpha$ then $\lambda = \beta$.

Proof. (i) Suppose the contrary. Then, $\lambda \notin \{\pm\alpha, \pm\beta\}$. Also, replacing λ by $-\lambda$ if needed, we may assume that $\langle \lambda, \alpha \rangle = \langle \lambda, \beta \rangle = -1$. Thus $\lambda + \beta$ is a root and $\langle \alpha, \lambda + \beta \rangle = -2$. Thus $\lambda + \beta = -\alpha$. This contradicts $(\lambda + \beta)(S_\alpha) = 0$.

(ii) Since $\delta + \lambda \in \Psi_\alpha$, $\langle \alpha, \delta + \lambda \rangle \leq 0$. But $\langle \alpha, \delta \rangle = 0$ and $\langle \alpha, \lambda \rangle \neq 0$, thus $\langle \alpha, \delta + \lambda \rangle < 0$ and thus $\delta + \lambda \in \Psi_\alpha \setminus \Phi_\alpha$. By Lemma 4.3.4(i), this implies $\delta + \lambda = \gamma$ and thus $\lambda = \beta$. \square

Recall that \mathfrak{X} denotes the set of next-to-minimal elements in $\mathfrak{g}_{-\alpha}^\times + \bigoplus_{\varepsilon \in \Psi_\alpha} \mathfrak{g}_{-\varepsilon}^*$. As before, for any root ε let ε^\vee denote the coroot given by the scalar product with ε . Note that $M_\alpha \cap \Gamma$ preserves \mathfrak{X} , since Ψ_α is the set of roots on which $S_\alpha - \alpha^\vee$ is at least 2 and S_α is 2, and M_α is the joint centralizer of α^\vee and S_α . For the rest of this section let

$$Z := \beta^\vee + 2^{-1}S_\alpha. \quad (4.17)$$

Note that $\alpha(Z) = \delta(Z) = 0$.

Lemma 4.3.6. (i) *Let $\varepsilon \neq \delta \in \Psi_\alpha$. Then $\varepsilon(Z) \in \{1, 2\}$.*

(ii) *The maximal eigenvalue of Z on \mathfrak{g} is 2.*

Proof. (i) Suppose the contrary. Since $\varepsilon(S_\alpha) = 2$ and $\varepsilon \neq \pm\beta$, this implies $\langle \beta, \varepsilon \rangle = -1$, and thus $\varepsilon + \beta$ is a root. Then $\langle \alpha, \varepsilon + \beta \rangle < 0$, and by Lemma 4.3.4(i) $\varepsilon + \beta = \gamma$. Thus $\varepsilon = \gamma - \beta = \delta$, contradicting the assumption.

(ii) We have to show that for any root μ , $\mu(Z) \leq 2$. If $\mu = \alpha_{\max}$ then $\mu(2^{-1}S_\alpha) = 2$ and $\mu(\beta^\vee) = 0$. If $\mu = \beta$ then $\mu(2^{-1}S_\alpha) = 0$ and $\mu(\beta^\vee) = 2$. For any other μ , $\max(\mu(2^{-1}S_\alpha), \mu(\beta^\vee)) \leq 1$. \square

We are now ready to prove Proposition 4.1.2. Let $x \in \mathfrak{X}$ and decompose it to a sum of root covectors $x = x_\alpha + \sum_{\varepsilon \in \Psi_\alpha} x_\varepsilon$ with $x_\varepsilon \in \mathfrak{g}_{-\varepsilon}^*$. Let $F := \{\varepsilon \in \Psi_\alpha \mid x_\varepsilon \neq 0\}$. By Lemma 3.3.1 F intersects Φ_α and thus, by Lemma 3.1.2, we can assume $\delta \in F$. Decompose $x = x_0 + x_1 + x_2$ with $x_i \in (\mathfrak{g}^*)_i^Z$. We have $x_0 = x_\alpha + x_\delta$. Applying Lemma 2.2.8 to $S := S_\alpha$ and Z , we obtain that there exists a nilpotent $X \in (\mathfrak{l}_\alpha)_{>0}^Z$ with

$$\text{ad}^*(X)(x_0) = x_1 + x_2. \quad (4.18)$$

Decompose X to a sum of root vectors $X = \sum_{\lambda \in \Psi} X_\lambda$, $X_\lambda \neq 0 \in \mathfrak{g}_{-\lambda}$, where Ψ is some set of roots. Choose some $X \in (\mathfrak{l}_\alpha)_{>0}^Z$ satisfying (4.18) such that the cardinality of Ψ is minimal possible.

Lemma 4.3.7. $X \in \mathfrak{m} := \text{Lie}(M_\alpha)$.

Proof. Since $X \in (\mathfrak{l}_\alpha)_{>0}^Z$, we have $\langle \beta, \lambda \rangle > 0$ for any $\lambda \in \Psi$. Suppose by way of contradiction $X \notin \mathfrak{m}$. Then $\langle \alpha, \lambda \rangle \neq 0$ for some $\lambda \in \Psi$. Fix such λ . Then Lemma 4.3.5(i) implies $\langle \alpha, \lambda \rangle < 0$ and thus $\langle \alpha, \lambda \rangle = -1$ and thus $\lambda + \alpha$ is a root and $[X_\lambda, x_\alpha] \neq 0$. By Lemma 4.3.4(ii), $\alpha + \lambda \notin \Psi_\alpha$, and thus this term has to be canceled by $[X_\mu, x_\delta]$ for some $\mu \in \Psi$. Thus $\mu = \alpha + \lambda - \delta$ is a root and thus $\langle \alpha + \lambda, \delta \rangle = 1$. But this contradicts

$$\langle \alpha + \lambda, \delta \rangle = \langle \lambda, \delta \rangle = \langle \lambda, \alpha_{\max} - \alpha - \beta \rangle = 0 + 1 - \langle \lambda, \beta \rangle \leq 0.$$

□

Thus $X \in \mathfrak{m}_{>0}^Z$. But $\mathfrak{m}_{>0}^Z = \mathfrak{m}_1^Z$. Thus $\text{ad}^*(X)(x_0) \in (\mathfrak{g}^*)_1^Z$ and thus $x_2 = 0$ and $\text{ad}^*(X)x_0 = x_1$. Let

$$y := \text{Exp}(-X)x - x_0 = -\text{ad}^*(X)(x_1) + 1/2(\text{ad}^*(X))^2(x_0). \quad (4.19)$$

The right-hand side of (4.19) has only these two terms because $X \in \mathfrak{g}_1^Z$, $x \in \mathfrak{g}_{\geq 0}^Z$, and $\mathfrak{g} = \mathfrak{g}_{\leq 2}^Z$. Since $\text{ad}^*(X)$ raises the Z -eigenvalues by 1, we get that $y \in (\mathfrak{g}^*)_2^Z$. Note that all the roots of y still lie in $\Psi_\alpha \setminus \{\delta\}$, since $X \in \mathfrak{m}$. Thus $x_0 + y \in \mathfrak{X}$. By the same argument as above, there exists $Y \in \mathfrak{m}_1^Z$ such that $\text{ad}^*(Y)(x_0) = y$. However, $\text{ad}^*(Y)(x_0) \in (\mathfrak{g}^*)_1^Z$ and thus $y = 0$. Thus $\text{Exp}(-X)x = x_0 = x_\alpha + x_\delta$, i.e. we can conjugate x using $\text{Exp}(-X) \in M_\alpha \cap \Gamma$ into $\mathfrak{g}_{-\alpha}^\times + \mathfrak{g}_{-\delta}^\times$. This proves Proposition 4.1.2. □

Remark 4.3.8. The assumption that G_α is not of type D_n is necessary, since in type D_n the Heisenberg root is α_2 and the set $\Phi_{\alpha_2} \subset \Psi_{\alpha_2}$ intersects both complex next-to-minimal orbits. Indeed, let $\lambda := \alpha_1 + \alpha_2 + \alpha_3$ and $\mu := \alpha_2 + 2 \sum_{i=3}^{n-2} \alpha_i + \alpha_{n-1} + \alpha_n$. Then $\mathfrak{g}_{-\alpha}^\times + \mathfrak{g}_{-\lambda}^\times$ belongs to the orbit given by the partition $2^{41^{n-4}}$, and $\mathfrak{g}_{-\alpha}^\times + \mathfrak{g}_{-\mu}^\times$ belongs to the orbit given by the partition 31^{n-3} . To see this note that in the ε notation we have $\alpha = \varepsilon_2 - \varepsilon_3$, $\lambda = \varepsilon_1 - \varepsilon_4$ and $\mu = \varepsilon_2 + \varepsilon_3$.

5. DETAILED EXAMPLES

In this section we will illustrate how to use the framework introduced above to compute certain Fourier coefficients in detail, many of which are of particular interest in string theory. In particular, we will in §5.1 show examples for D_5 with detailed steps and deformations that reproduce the results of Theorems A, B and C, while in the following sections we will illustrate how to apply these theorems in different examples.

As in previous sections we will here often identify $\varphi \in \mathfrak{g}^*$ with its Killing form dual $f_\varphi \in \mathfrak{g}$. Since we have also seen that it is convenient to specify a Cartan element $S \in \mathfrak{h}$ by how the simple roots α_i act on S we will make use of the fundamental coweights $\omega_j^\vee \in \mathfrak{h}$ satisfying $\alpha_i(\omega_j^\vee) = \delta_{ij}$.

5.1. Examples for D_5 . In the following examples we will consider $G = \text{Spin}_{5,5}(\mathbb{A})$ with $\Gamma = \text{Spin}_{5,5}(\mathbb{K})$. We use the conventional Bourbaki labelling of the roots shown in Figure 2. The complex nilpotent orbits for D_5 are labeled by certain integer partitions of 10 with a partial ordering illustrated in the Hasse diagram of Figure 3 where \mathcal{O}_{110} is the trivial orbit and \mathcal{O}_{2216} the minimal orbit. Note that this ordering is based on the closure on complex orbits and not on the partial ordering that we introduced in [GGK⁺]. There is no unique next-to-minimal orbit and both \mathcal{O}_{2412} and \mathcal{O}_{317} can occur as Whittaker supports of

automorphic forms arising in string theory. These two complex orbits are usually denoted $(2A_1)'$ and $(2A_1)''$ in Bala–Carter notation [CM93] with $2A_1$ indicating two orthogonal simple roots and the primes distinguish the two possible pairs (up to Weyl conjugation, see Lemma 3.0.4).

We will focus on examples of importance in string theory. In particular we consider expansions in the string perturbation limit associated to the maximal parabolic subgroup P_{α_1} and the decompactification limit associated to P_{α_5} discussed in section 1.9. The Fourier coefficients computed in (5.3) and (5.8) below have previously been computed for particular Eisenstein series in [GMV15] equations (4.84) and (4.88) respectively; although with very different methods using theta lifts. While the Fourier coefficient (5.3) for a minimal automorphic form is readily checked to be of the same form as [GMV15, (4.84)], the comparison between Fourier coefficient (5.8) for a next-to-minimal automorphic form and [GMV15, (4.88)] is a bit more intricate and will be discussed further in Remark 5.1.1 below.

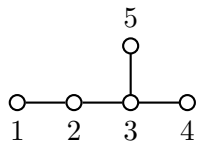

FIGURE 2. Root labels used for D_5 .

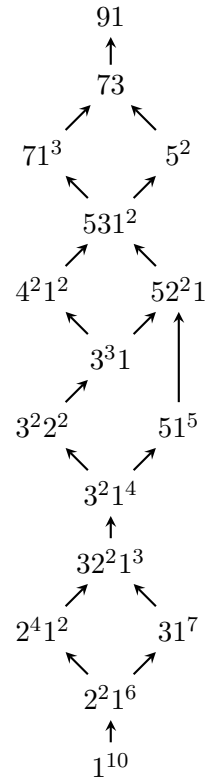

FIGURE 3. Hasse diagram of nilpotent orbits for D_5 with respect to the closure ordering on complex orbits. There are two non-special orbits given by $3 2^2 1^3$ and $5 2^2 1$.

5.1.1. *Minimal representation.* We will start with considering a minimal automorphic function η_{\min} on $G = \mathrm{Spin}_{5,5}(\mathbb{A})$. Such a minimal automorphic form can for instance be obtained as a residue of a maximal parabolic Eisenstein series [GRS97, GMV15, FGKP18]. We will compute the Fourier coefficients of η_{\min} with respect to the unipotent radical of the maximal parabolic subgroup P_{α_1} associated to the root α_1 , which is the string perturbation limit discussed in §1.9 and the corresponding Levi subgroup L_{α_1} has semisimple part of type D_4 .

We may describe such Fourier coefficients by Whittaker pairs (S_{α_1}, φ) where $S_{\alpha_1} = 2\omega_1^\vee$ and $\varphi \in (\mathfrak{g}^*)_{-2}^{S_{\alpha_1}}$. Indeed, the associated Fourier coefficient $\mathcal{F}_{S_{\alpha_1}, \varphi}$ is then the expected period integral over $N_{S_{\alpha_1}, \varphi} = U_{\alpha_1}$, the unipotent radical of P_{α_1} , where we recall that $N_{S_{\alpha_1}, \varphi}$ is given by (2.5).

$$\mathcal{F}_{S_{\alpha_1}, \varphi}[\eta_{\min}](g) := \int_{(U_{\alpha_1} \cap \Gamma) \backslash U_{\alpha_1}} \eta_{\min}(ug) \varphi(u)^{-1} du. \quad (5.1)$$

As in previous sections we will use the shorthand notation $[U] = (U \cap \Gamma) \backslash U$ for the compact quotient of a unipotent subgroup U .

Since η_{\min} is minimal, Theorem A(iii) gives that $\mathcal{F}_{S_{\alpha_1}, \varphi}[\eta_{\min}]$ is non-vanishing only if $\varphi \in \mathcal{O}_{\min} = \mathcal{O}_{2216}$ or $\varphi = 0$. We will now consider the former. The latter can be computed using Theorem B with G of type D_4 or the results from [MW95] for Eisenstein series.

By Corollary 3.1.3(i), $\varphi \in \mathcal{O}_{\min}$ can be conjugated to $\varphi' = \mathrm{Ad}^*(\gamma_0)\varphi \in \mathfrak{g}_{-\alpha_1}^\times$ by an element $\gamma_0 \in L_{\alpha_1} \cap \Gamma$. This conjugation leaves the integration domain invariant, or, equivalently, we may use Lemma 2.2.1 to obtain

$$\mathcal{F}_{S_{\alpha_1}, \varphi}[\eta_{\min}](g) = \mathcal{F}_{S_{\alpha_1}, \varphi'}[\eta_{\min}](\gamma_0 g). \quad (5.2)$$

The unipotent radical U_{α_1} is a subgroup of the unipotent radical N of our fixed Borel subgroup, and we may make further Fourier expansions along the complement of U_{α_1} in N . Of these Fourier coefficients, only the constant term survives since such non-trivial characters, combined with φ' are in a larger orbit than \mathcal{O}_{\min} and therefore do not contribute according to Corollary 2.2.5. By repeating these arguments, or equivalently use Lemma 3.1.1 based on a special case of Theorem 2.2.6 (where V is trivial), we obtain that

$$\mathcal{F}_{S_{\alpha_1}, \varphi}[\eta_{\min}](g) = \mathcal{W}_{\varphi'}[\eta_{\min}](\gamma_0 g) := \int_{(N \cap \Gamma) \backslash N} \eta_{\min}(n\gamma_0 g) \varphi'(n)^{-1} dn, \quad (5.3)$$

confirming Theorem A(ii) for this case.

5.1.2. *Next-to-minimal representations.* Let η_{ntm} be a next-to-minimal automorphic form on $G = \mathrm{Spin}_{5,5}(\mathbb{A})$. Since there are two next-to-minimal orbits for D_5 there are two cases to consider. We begin with automorphic forms associated with the next-to-minimal orbit $\mathrm{WS}(\eta_{\mathrm{ntm}}) = \{\mathcal{O}_{317}\}$ that has dimension 16, also known as $(2A_1)'$ in Bala-Carter notation. Let also $P_{\alpha_1} = L_{\alpha_1} U_{\alpha_1}$ be the maximal parabolic subgroup of G with respect to the simple root α_1 such that the Levi subgroup L_{α_1} has semisimple part of type D_4 . Automorphic forms with the above Whittaker support can for example be obtained as generic elements of the degenerate principal series of maximal parabolic Eisenstein series associated with P_{α_1} .

We will now compute the Fourier coefficients of η_{ntm} with respect to U_{α_1} using Theorem C. These are described by Whittaker pairs (S_{α_1}, φ) where $S_{\alpha_1} = 2\omega_1^\vee$ and $\varphi \in (\mathfrak{g}^*)_{-2}^{S_{\alpha_1}}$. The case $\varphi = 0$ can be treated using Theorem D with G of type D_4 . According to Theorem C or Corollary 2.2.5, we are thus left with φ being minimal or next-to-minimal where the latter in this case only gives non-vanishing Fourier coefficients for $\varphi \in \mathcal{O}_{317}$ and not \mathcal{O}_{2412} .

A minimal element $\varphi = \varphi_{\min} \in \mathcal{O}_{\min} = \mathcal{O}_{2216}$ can be conjugated to some standard form $\psi = \text{Ad}^*(\gamma_{\min})\varphi_{\min} \in \mathfrak{g}_{-\alpha_1}^\times$ where $\gamma_{\min} \in L_{\alpha_1} \cap \Gamma$ using Corollary 3.1.3(i). From Lemma 2.2.1 we then have that

$$\mathcal{F}_{S_{\alpha_1}, \varphi_{\min}}[\eta_{\text{ntm}}](g) = \mathcal{F}_{S_{\alpha_1}, \psi}[\eta_{\text{ntm}}](\gamma_{\min}g). \quad (5.4)$$

Let $I^{(\perp\alpha_1)} = (\beta_1, \beta_2, \beta_3) := (\alpha_5, \alpha_4, \alpha_3)$ and L_i be the Levi subgroup of G obtained from a subsequence of simple roots $(\beta_1, \dots, \beta_i)$ of $I^{(\perp\alpha_1)}$. Each semisimple part of L_i has simple components of type A for which all simple roots are abelian according to Table 1, and thus $I^{(\perp\alpha_1)}$ is an abelian enumeration. Using Theorem C(ii) we obtain

$$\mathcal{F}_{S_{\alpha_1}, \varphi_{\min}}[\eta_{\text{ntm}}](g) = \mathcal{W}_\psi[\eta_{\text{ntm}}](\gamma_{\min}g) + \sum_{i=1}^3 C_i^\psi[\eta_{\text{ntm}}](\gamma_{\min}g) \quad (5.5)$$

where

$$C_i^\psi[\eta_{\text{ntm}}](\gamma_{\min}g) = A_i^\psi[\eta_{\text{ntm}}](\gamma_{\min}g) = \sum_{\gamma \in \Gamma_{i-1}} \sum_{\varphi' \in \mathfrak{g}_{-\beta_i}^\times} \mathcal{W}_{\psi+\varphi'}[\eta_{\text{ntm}}](\gamma\gamma_{\min}g). \quad (5.6)$$

As explained in Section 1.4, Γ_{i-1} is defined as follows. Let Q_{i-1} denote the parabolic subgroup of L_{i-1} given by the restriction of β_i^\vee to L_{i-1} . Then Q_{i-1} is the stabilizer in L_{i-1} of the root space $\mathfrak{g}_{-\beta_i}^*$ of L_i . Then $\Gamma_{i-1} = (L_{i-1} \cap \Gamma)/(Q_{i-1} \cap \Gamma)$ with $\Gamma_0 = \{1\}$. Concretely, we may take the representatives

$$\Gamma_0 = \Gamma_1 = \{1\} \quad \Gamma_2 = \{1\} \cup w_4 \text{Exp}(\mathfrak{g}_{-\alpha_4}) \cup w_5 \text{Exp}(\mathfrak{g}_{-\alpha_5}) \cup w_4 w_5 \text{Exp}(\mathfrak{g}_{-\alpha_4} \oplus \mathfrak{g}_{-\alpha_5}) \quad (5.7)$$

where w_i is a representative in Γ of the simple reflection corresponding to the simple root α_i . The last equality in (5.7) is the Bruhat decomposition of Γ_2 and is isomorphic to $\mathbb{P}^1(\mathbb{K}) \times \mathbb{P}^1(\mathbb{K})$.

Let us now consider next-to-minimal characters $\varphi = \varphi_{\text{ntm}} \in (\mathfrak{g}^*)_{-2}^{S_{\alpha_1}}$ instead. By Proposition 4.0.1, $L_\alpha \cap \Gamma$ acts transitively on these next-to-minimal characters, and from Lemma 3.3.1 we have that elements of $\mathfrak{g}_{-\alpha_1}^\times + \mathfrak{g}_{-\alpha_{\max}}^\times \subset (\mathfrak{g}^*)_{-2}^{S_{\alpha_1}}$ are next-to-minimal. In fact, $\varphi_{\text{ntm}} \in \mathcal{O}_{317}$ since $\mathfrak{g}_{-\alpha_1}^\times + \mathfrak{g}_{-\alpha_{\max}}^\times$ can be Weyl reflected to $\mathfrak{g}_{-\alpha_4}^\times + \mathfrak{g}_{-\alpha_5}^\times$ which are known to be in \mathcal{O}_{317} . Indeed, by Corollary 3.0.2 there is a Weyl word w that moves the roots α_1 and α_{\max} to two orthogonal simple roots, and from the proof of the Corollary we have that these roots have to be α_4 and α_5 .

Lemma 2.2.1 together with Theorem C(iii) for any of these choices give

$$\begin{aligned} \mathcal{F}_{S_{\alpha_1}, \varphi_{\text{ntm}}}[\eta_{\text{ntm}}](g) &= \mathcal{F}_{S_{\alpha_1}, \text{Ad}^*(\gamma_{\text{ntm}})\varphi_{\text{ntm}}}[\eta_{\text{ntm}}](\gamma_{\text{ntm}}g) \\ &= \int_V \mathcal{W}_{\text{Ad}^*(w\gamma_{\text{ntm}})\varphi_{\text{ntm}}}[\eta_{\text{ntm}}](vw\gamma_{\text{ntm}}g) dv \end{aligned} \quad (5.8)$$

with $V = \text{Exp}(\mathfrak{v})(\mathbb{A})$ where $\mathfrak{v} = \mathfrak{g}_{-\alpha_3} \oplus \mathfrak{g}_{-\alpha_2-\alpha_3} \oplus \mathfrak{g}_{-\alpha_1-\alpha_2-\alpha_3}$.

Remark 5.1.1. We may now revisit the comparison between (5.8) and the Fourier coefficient [GMV15, (4.88)] for a particular Eisenstein series. The latter is expressed in of double divisor sums and a single Bessel function. Specifying to the same Eisenstein series in (5.8), the Whittaker coefficient on the right-hand side resolves to a product of two (single) divisor sums and two Bessel functions (see for example [FGKP18]). We expect that the non-compact adelic integral in (5.8) will allow us to relate the two expressions, something that will require further investigation.

Lastly, we will consider the other other next-to-minimal orbit $\mathcal{O}_{2^4 1^2}$ of dimension 20 and Bala-Carter label $(2A_1)''$. That is, consider η_{ntm} such that $\text{WS}(\eta_{\text{ntm}}) = \{\mathcal{O}_{2^4 1^2}\}$. Such an automorphic form can, for example, be obtained as generic elements of the degenerate principal series of maximal parabolic Eisenstein series associated with P_{α_4} or P_{α_5} . We showed above that all the next-to-minimal elements in $(\mathfrak{g}^*)_{-2}^{S_{\alpha_1}}$ are in \mathcal{O}_{31^7} and thus the corresponding next-to-minimal Fourier coefficients $\mathcal{F}_{S_{\alpha_1}, \varphi}[\eta_{\text{ntm}}]$ would vanish.

Therefore, we will here consider another parabolic subgroup $P_{\alpha_5} = L_{\alpha_5} U_{\alpha_5}$ associated with the root α_5 such that L_{α_5} has semi-simple part of type A_4 . Let $S_{\alpha_5} = 2\omega_5^\vee$ and φ_{ntm} a next-to-minimal element in $(\mathfrak{g}^*)_{-2}^{S_{\alpha_5}}$. Similar to above, $L_{\alpha_5} \cap \Gamma$ acts transitively on this space by Proposition 4.0.1, and from Lemma 3.3.1 we have that elements of $\mathfrak{g}_{-\alpha_5}^\times + \mathfrak{g}_{-\alpha_{\max}}^\times \subset (\mathfrak{g}^*)_{-2}^{S_{\alpha_5}}$ are next-to-minimal. Let therefore $\gamma_{\text{ntm}} \in L_{\alpha_5} \cap \Gamma$ such that $\text{Ad}^*(\gamma_{\text{ntm}})\varphi_{\text{ntm}} \in \mathfrak{g}_{-\alpha_i}^\times + \mathfrak{g}_{-\alpha_j}^\times$.

Furthermore, by Corollary 3.0.4 there exists a Weyl word w_{ij} , and simple roots α_i and α_j such that $\text{Ad}^*(w_{ij}\gamma_{\text{ntm}})\varphi_{\text{ntm}} \in \mathfrak{g}_{-\alpha_i}^\times + \mathfrak{g}_{-\alpha_j}^\times$ with the possible choices listed in (5.10) below, up to interchanging the two roots. For any (and therefore all) such choices of simple roots α_i and α_j it is known that $\mathfrak{g}_{-\alpha_i}^\times + \mathfrak{g}_{-\alpha_j}^\times \subset \mathcal{O}_{2^4 1^2}$ and thus $\varphi_{\text{ntm}} \in \mathcal{O}_{2^4 1^2}$.

For any of the choices, Lemma 2.2.1 together with Theorem C(iii) gives

$$\begin{aligned} \mathcal{F}_{S_{\alpha_5}, \varphi_{\text{ntm}}}[\eta_{\text{ntm}}](g) &= \mathcal{F}_{S_{\alpha_5}, \text{Ad}^*(\gamma_{\text{ntm}})\varphi_{\text{ntm}}}[\eta_{\text{ntm}}](\gamma_{\text{ntm}}g) \\ &= \int_{V_{ij}} \mathcal{W}_{\text{Ad}^*(w_{ij}\gamma_{\text{ntm}})\varphi_{\text{ntm}}}[\eta_{\text{ntm}}](vw_{ij}\gamma_{\text{ntm}}g) dv \end{aligned} \quad (5.9)$$

where $V_{ij} = \text{Exp}(\mathfrak{v}_{ij})(\mathbb{A})$ and $\mathfrak{v}_{ij} = \mathfrak{v}_{ji}$ can be read from the following table using the notation $\alpha_{m_1 m_2 m_3 m_4 m_5} = \sum_{i=1}^5 m_i \alpha_i$.

α_i	α_j	$\mathfrak{v}_{ij} = \mathfrak{v}_{ji}$
α_1	α_3	$\mathfrak{g}_{-\alpha_{00010}} \oplus \mathfrak{g}_{-\alpha_{01000}} \oplus \mathfrak{g}_{-\alpha_{01110}} \oplus \mathfrak{g}_{-\alpha_{01111}}$
α_1	α_4	$\mathfrak{g}_{-\alpha_{01000}} \oplus \mathfrak{g}_{-\alpha_{01100}} \oplus \mathfrak{g}_{-\alpha_{01101}}$
α_1	α_5	$\mathfrak{g}_{-\alpha_{00100}} \oplus \mathfrak{g}_{-\alpha_{00110}} \oplus \mathfrak{g}_{-\alpha_{01100}} \oplus \mathfrak{g}_{-\alpha_{01110}} \oplus \mathfrak{g}_{-\alpha_{01211}}$
α_2	α_4	$\mathfrak{g}_{-\alpha_{00100}} \oplus \mathfrak{g}_{-\alpha_{00101}}$
α_2	α_5	$\mathfrak{g}_{-\alpha_{00100}} \oplus \mathfrak{g}_{-\alpha_{10000}} \oplus \mathfrak{g}_{-\alpha_{00110}} \oplus \mathfrak{g}_{-\alpha_{11100}} \oplus \mathfrak{g}_{-\alpha_{11110}} \oplus \mathfrak{g}_{-\alpha_{11211}}$

As one can see from the above table, the size of V depends strongly on the choice of representative roots. The smallest choice is obtained in the fourth row.

5.2. An E_8 -example. In this section we will illustrate our general results in the context of automorphic forms on E_8 . We will give the complete Fourier expansion in the minimal and

next-to-minimal representations along a Heisenberg parabolic subgroup, see Proposition 2.2.7 for a general discussion of such expansions. We also discuss relations with related results in the literature.

5.2.1. *The explicit Fourier expansions of η_{\min} and η_{ntm} .* We will now illustrate Theorems B, E and F in the case of E_8 . According to theorems B and E the general structure of the expansions of automorphic forms η_{\min} and η_{ntm} attached to the minimal and next-to-minimal representation of E_8 are given by

$$\eta_{\min} = \mathcal{F}_{S_{\alpha},0}[\eta_{\min}] + A_n + B_n, \quad (5.11)$$

$$\eta_{\text{ntm}} = \mathcal{F}_{S_{\alpha},0}[\eta_{\text{ntm}}] + A_n + A_{nn} + \sum_{\substack{j < n \\ j \perp n}} A_{nj} + B_n + B_{nn} + \sum_{\substack{j < n \\ j \perp n}} B_{nj}, \quad (5.12)$$

where the definitions of the individual terms are given in sections 1.4 and 1.7.

To illustrate this more explicitly we now pick the Bourbaki enumeration as in Theorem F that is quasi-abelian for E_8 . Let $P = LU$ be the Heisenberg parabolic of E_8 , with Levi $L = E_7 \times GL_1$ and unipotent U a 57-dimensional Heisenberg group with one-dimensional center $C = [U, U]$. This corresponds to expanding with respect to the Heisenberg root $\alpha = \alpha_8$. In its full glory the expansion now amounts to the following expression in the minimal case

$$\eta_{\min}(g) = \mathcal{F}_{S_{\alpha_8},0}[\eta_{\min}](g) + \sum_{\gamma \in \Gamma_7} \sum_{\varphi \in \mathfrak{g}_{-\alpha_8}^{\times}} \mathcal{W}_{\varphi}[\eta_{\min}](\gamma g) + \sum_{\omega \in \Omega_8} \sum_{\varphi \in \mathfrak{g}_{-\alpha_8}^{\times}} \mathcal{W}_{\varphi}[\eta_{\min}](\omega \gamma_8 g), \quad (5.13)$$

and for the next-to-minimal representation we have a slightly more complicated expression

$$\begin{aligned} \eta_{\text{ntm}}(g) &= \mathcal{F}_{S_{\alpha_8},0}(g) + \underbrace{\sum_{\gamma \in \Gamma_7} \sum_{\varphi \in \mathfrak{g}_{-\alpha_8}^{\times}} \mathcal{W}_{\varphi}(\gamma g)}_{A_8} + \underbrace{\sum_{j=1}^6 \sum_{\gamma' \in \Gamma_7} \sum_{\varphi \in \mathfrak{g}_{-\alpha_8}^{\times}} \sum_{\gamma \in \Gamma_{j-1}} \sum_{\psi \in \mathfrak{g}_{-\beta_j}^{\times}} \mathcal{W}_{\varphi+\psi}(\gamma \gamma' g)}_{A_{8j}} \\ &+ \underbrace{\frac{1}{2} \sum_{\tilde{\gamma} \in \Lambda_{\alpha_8}} \sum_{\varphi \in \mathfrak{g}_{-\alpha_8}^{\times}} \sum_{\psi \in \mathfrak{g}_{-\delta_8}^{\times}} \int_{V_{g_8}} \mathcal{W}_{\varphi+\psi}(v g_8 \tilde{\gamma} g) dv}_{A_{88}} + \underbrace{\sum_{\omega \in \Omega_8} \sum_{\varphi \in \mathfrak{g}_{-\alpha_8}^{\times}} \mathcal{W}_{\varphi}(\omega \gamma_8 g)}_{B_8} \\ &+ \underbrace{\sum_{\omega \in \Omega_8} \sum_{\tilde{\gamma} \in \mathcal{M}_{\alpha_8}} \sum_{\varphi \in \mathfrak{g}_{-\alpha_8}^{\times}} \sum_{\psi \in \mathfrak{g}_{-\delta_8}^{\times}} \int_V \mathcal{W}_{\varphi+\psi}(v \tilde{\gamma} \omega \gamma_8 g) dv}_{B_{88}} \\ &+ \underbrace{\sum_{j=1}^6 \sum_{\omega \in \Omega_8} \sum_{\varphi \in \mathfrak{g}_{-\alpha_8}^{\times}} \sum_{\gamma \in \Gamma_{j-1}} \sum_{\psi \in \mathfrak{g}_{-\beta_j}^{\times}} \mathcal{W}_{\varphi+\psi}(\gamma \omega \gamma_8 g)}_{B_{8j}}, \end{aligned} \quad (5.14)$$

where all coefficients are evaluated for the automorphic form $\eta = \eta_{\text{ntm}}$. The elements g_8 and γ_8 are defined in §1.7 and §1.4, respectively,

As discussed in section 1.1 the expansion can be separated into an abelian contribution and a non-abelian contribution. The form of the expansion given above reflects this structure, as we now explain in more detail. We focus on the next-to-minimal case as this is the more complicated case.

Let ψ_U be a unitary character on $U(\mathbb{A})$, trivial on $U(\mathbb{K})$. It is supported only on the abelianization $U^{\text{ab}} = C \backslash U$. The *abelian contribution* to the Fourier expansion is then given by the constant term with respect to the center of the Heisenberg group

$$\int_{C(\mathbb{K}) \backslash C(\mathbb{A})} \eta_{\text{ntm}}(zg) dz \quad (5.15)$$

which can be expanded into a Fourier sum of the form \sum_{ψ_U} where we sum over all characters ψ_U . The first term in the expansion $\mathcal{F}_{S_{\alpha_8}, 0}[\eta_{\text{ntm}}](g)$ is the constant term of η_{ntm} with respect to U , i.e. corresponding to the contribution with trivial character ψ_U . The abelian part, corresponding to terms labelled *A*, of the non-trivial Fourier coefficients is made up of the second, third and fourth terms on the right-hand side of equation (5.14). The first of these is attached to the minimal orbit \mathcal{O}_{min} while the last two are attached to \mathcal{O}_{ntm} . These coefficients are not sufficient to recreate the entire automorphic form η_{ntm} ; we also need to consider the contributions from non-trivial characters on the center C . Let ψ_C be a *non-trivial* character on $C(\mathbb{A})$, trivial on $C(\mathbb{K})$. The non-abelian contribution to the Fourier expansion is then given schematically by

$$\sum_{\psi_C} \int_{C(\mathbb{K}) \backslash C(\mathbb{A})} \eta_{\text{ntm}}(zg) \psi_C(z)^{-1} dz. \quad (5.16)$$

This makes up the remaining three terms in equation (5.14), corresponding to terms labelled *B*. We note that the non-abelian terms contain the transformation γ_8 mapping α_{max} to α_8 , signalling the fact they come originally from a non-trivial character on the center of the Heisenberg group. The first one represents the contribution from \mathcal{O}_{min} , while the last two (bottom line) capture the contribution from \mathcal{O}_{ntm} .

5.2.2. *Comparison with related results in the literature.* Various works have determined similar Fourier coefficients of small representations in special cases and we now briefly compare our results to them, with a particular emphasis on the E_8 expansions.

We begin with the example of a minimal automorphic form η on E_8 with the expansion determined in (5.13), that was also studied by Ginzburg–Rallis–Soudry [GRS11] and by Kazhdan–Polishchuk [KP04].

In [GRS11], Ginzburg–Rallis–Soudry showed that the constant term of η_{min} with respect to the center C of the Heisenberg unipotent U of E_8 was given by a single Levi (i.e. E_7) orbit of a Fourier coefficient $\mathcal{F}_{\psi_{\alpha_8}}$ on U , where ψ_{α_8} is a character on U supported only on the single simple root α_8 . This corresponds precisely to the second term in (5.13). Our results generalize this by also determining $\mathcal{F}_{\psi_{\alpha_8}}$ explicitly in terms of Whittaker coefficients $\mathcal{W}_{\varphi}[\eta_{\text{min}}]$.

In [KP04], the authors give an explicit form of the full non-abelian Fourier expansion of η with respect to U and our result (5.13) is perfectly consistent with theirs. Kazhdan and Polishchuk have, however, a different approach, where they first determine the local contributions (spherical vectors) to the Fourier coefficients and then assemble them together

into a global automorphic functional. To connect the two results one must therefore evaluate the Whittaker coefficients in (5.13) and extract their contributions at each local place. For the abelian terms, this has in fact already been done in [GKP16] and by combining those results with ours one achieves perfect agreement with [KP04]. It remains to evaluate explicitly the Whittaker coefficient in the last term of equation (5.13), corresponding to B_8 , and extract its Euler product. It would be of particular interest to see if one can reproduce the cubic phase in the spherical vectors of [KP04] in this way.

Next we turn to the Fourier expansion of an E_8 automorphic form in the next-to-minimal representation given in (5.14) that has been studied previously by Bossard–Pioline [BP17]. According to the discussion in §1.9 the decomposition in (5.14) corresponds to the decompactification limit and an expression for the abelian part of the Fourier expansion for the next-to-minimal spherical Eisenstein series on E_8 was given in [BP17, Eq. (3.15)] that we reproduce here for convenience

$$\begin{aligned}
\eta &= \mathcal{F}_{S_\alpha,0}[\eta] + 16\pi\xi(4)R^4 \sum_{\substack{\Gamma \in \mathcal{L}_\alpha \\ \Gamma \times \Gamma = 0}} \sigma_8(\Gamma) \frac{K_4(2\pi R|Z(\Gamma)|)}{|Z(\Gamma)|^4} e^{2\pi i \langle \Gamma, a \rangle} \\
&+ 16\pi\xi(3)R \sum_{\substack{\Gamma \in \mathcal{L}_\alpha \\ \Gamma \times \Gamma = 0}} \sigma_2(\Gamma) (\gcd \Gamma)^2 \eta_{\min}^{E_6} \frac{K_1(2\pi R|Z(\Gamma)|)}{|Z(\Gamma)|^3} e^{2\pi i \langle \Gamma, a \rangle} \\
&+ 16\pi R^{-5} \sum_{\substack{\Gamma \in \mathcal{L}_\alpha \\ \Gamma \times \Gamma \neq 0, I'_4(\Gamma) = 0}} \sum_{n|\Gamma} n^{d+1} \sigma_3\left(\frac{\Gamma \times \Gamma}{n^2}\right) \frac{B_{5/2,3/2}(R^2|Z(\Gamma)|^2, R^2\sqrt{\Delta(\Gamma)})}{\Delta(\Gamma)^{3/4}} e^{2\pi i \langle \Gamma, a \rangle} + \dots
\end{aligned} \tag{5.17}$$

Here, explicit coordinates on $E_8/(\text{Spin}_{16}/\mathbb{Z}_2)$ adapted to the E_7 parabolic are used. Specifically, R is a coordinate for the GL_1 factor in the Levi and a denotes (axionic) coordinates on the 56-dimensional abelian part of the unipotent. \mathcal{L}_α is a lattice in this 56-dimensional representation of E_7 and the coordinates on the E_7 factor of the Levi enter implicitly through the functions $Z(\Gamma)$ and $\Delta(\Gamma)$. We do not require their precise form for the present comparison. K_s denotes the modified Bessel function and $\eta_{\min}^{E_6}$ a spherical vector in the minimal representation of E_6 .

We now establish that (5.17) and (5.14) are compatible. The Fourier expansion in (5.17) is written in terms of sums over charges Γ in the integral lattice \mathcal{L}_α in the 56-dimensional unipotent and thus resembles structurally (5.14) above as the space $(\mathfrak{g}^*)_{-2}^{S_\alpha}$ represents the space of characters on this unipotent. The Fourier mode for a ‘charge’ Γ is given by $e^{2\pi i \langle \Gamma, a \rangle}$ and is the character on $(\mathfrak{g}^*)_{-2}^{S_\alpha}$. Besides the constant term $\mathcal{F}_{S_\alpha,0}[\eta]$ there is a sum over characters in the minimal and next-to-minimal orbits within $(\mathfrak{g}^*)_{-2}^{S_\alpha}$; the last term in our (5.14) is a non-abelian term that was not determined in [BP17].

Minimal characters correspond to charges Γ such that they satisfy the (rank-one) condition $\Gamma \times \Gamma = 0$ in the notation of [BP17] and looking at (5.17) we see that there are two contributions from such charges. These correspond exactly to the two terms A_8 and A_{8j} in the first line of our (5.14): The first term A_8 represents the purely minimal charges while the second term A_{8j} in our equation is the second line of (5.17) where a minimal charge is combined with a minimal automorphic form on E_6 . Expanding this minimal automorphic form on E_6 leads to Whittaker coefficients of the form $\mathcal{W}_{\varphi+\psi}$ as they are given in the third

term of the of the first line in (5.14), i.e. corresponding to A_{8j} . The sums over j , Γ_{j-1} and $\mathfrak{g}_{-\beta_j}^\times$ in our expression correspond to the E_7 orbits of such charges Γ . The term A_{88} in our formula (5.14) contains a non-compact integral over Whittaker coefficient $\mathcal{W}_{\varphi+\psi}$ and corresponds to the last line in (5.17) where a similar integrated Whittaker coefficient $B_{5/2,3/2}$ appears. The non-abelian terms with B -labels in the last line of (5.14) have not been determined in [BP17] and are given by the ellipses in (5.17).

REFERENCES

- [AGK⁺18] O. Ahlén, H. P. A. Gustafsson, A. Kleinschmidt, B. Liu, and D. Persson, “Fourier coefficients attached to small automorphic representations of $\mathrm{SL}_n(\mathbb{A})$,” *J. Number Theory* **192** (2018) 80–142, [arXiv:1707.08937](#) [math.RT].
- [BD01] J.-L. Brylinski and P. Deligne, “Central extensions of reductive groups by \mathbf{K}_2 ,” *Publ. Math. Inst. Hautes Études Sci.* no. 94, (2001) 5–85.
- [BKN⁺10] L. Bao, A. Kleinschmidt, B. E. W. Nilsson, D. Persson, and B. Pioline, “Instanton corrections to the universal hypermultiplet and automorphic forms on $\mathrm{SU}(2,1)$,” *Commun. Num. Theor. Phys.* **4** (2010) 187–266, [arXiv:0909.4299](#) [hep-th].
- [Bou75] N. Bourbaki, *Éléments de mathématique. Fasc. XXXVIII: Groupes et algèbres de Lie. Chapitre VII: Sous-algèbres de Cartan, éléments réguliers. Chapitre VIII: Algèbres de Lie semi-simples déployées*. Actualités Scientifiques et Industrielles, No. 1364. Hermann, Paris, 1975.
- [BP17] G. Bossard and B. Pioline, “Exact $\nabla^4 R^4$ couplings and helicity supertraces,” *JHEP* **01** (2017) 050, [arXiv:1610.06693](#) [hep-th].
- [CM93] D. H. Collingwood and W. M. McGovern, *Nilpotent orbits in semisimple Lie algebras*. Van Nostrand Reinhold Mathematics Series. Van Nostrand Reinhold Co., New York, 1993.
- [CS80] W. Casselman and J. Shalika, “The unramified principal series of p -adic groups. II. The Whittaker function,” *Compositio Math.* **41** no. 2, (1980) 207–231.
- [DGV15] E. D’Hoker, M. B. Green, and P. Vanhove, “On the modular structure of the genus-one type II superstring low energy expansion,” *J. High Energy Phys.* no. 8, (2015) 041, [front matter+66](#).
- [FGKP18] P. Fleig, H. P. A. Gustafsson, A. Kleinschmidt, and D. Persson, *Eisenstein series and automorphic representations*, vol. 176 of *Cambridge Studies in Advanced Mathematics*. Cambridge University Press, Cambridge, 2018. [arXiv:1511.04265](#) [math.NT].
- [FKP14] P. Fleig, A. Kleinschmidt, and D. Persson, “Fourier expansions of Kac-Moody Eisenstein series and degenerate Whittaker vectors,” *Commun. Num. Theor. Phys.* **08** (2014) 41–100, [arXiv:1312.3643](#) [hep-th].
- [GG97] M. B. Green and M. Gutperle, “Effects of D instantons,” *Nucl. Phys.* **B498** (1997) 195–227, [arXiv:hep-th/9701093](#) [hep-th].
- [GG98] M. B. Green and M. Gutperle, “D Particle bound states and the D instanton measure,” *JHEP* **01** (1998) 005, [arXiv:hep-th/9711107](#) [hep-th].
- [GGK⁺] D. Gourevitch, H. P. A. Gustafsson, A. Kleinschmidt, D. Persson, and S. Sahi, “A reduction principle for Fourier coefficients of automorphic forms,” [arXiv:1811.05966v2](#) [math.NT].
- [GGS] R. Gomez, D. Gourevitch, and S. Sahi, “Whittaker supports for representations of reductive groups,” *Annales de l’Institut Fourier*, [arXiv:1610.00284](#) [math.RT]. To appear.
- [GGS17] R. Gomez, D. Gourevitch, and S. Sahi, “Generalized and degenerate Whittaker models,” *Compos. Math.* **153** no. 2, (2017) 223–256.
- [Gin06] D. Ginzburg, “Certain conjectures relating unipotent orbits to automorphic representations,” *Israel J. Math.* **151** (2006) 323–355.
- [Gin14] D. Ginzburg, “Towards a classification of global integral constructions and functorial liftings using the small representations method,” *Adv. Math.* **254** (2014) 157–186.
- [GKP16] H. P. A. Gustafsson, A. Kleinschmidt, and D. Persson, “Small automorphic representations and degenerate Whittaker vectors,” *J. Number Theor.* **166** (2016) 344–399, [arXiv:1412.5625](#) [math.NT].

- [GMV15] M. B. Green, S. D. Miller, and P. Vanhove, “Small representations, string instantons, and Fourier modes of Eisenstein series,” *J. Number Theor.* **146** (2015) 187–309, [arXiv:1111.2983 \[hep-th\]](#).
- [GRS97] D. Ginzburg, S. Rallis, and D. Soudry, “On the automorphic theta representation for simply laced groups,” *Israel J. Math.* **100** (1997) 61–116.
- [GRS11] D. Ginzburg, S. Rallis, and D. Soudry, *The descent map from automorphic representations of $GL(n)$ to classical groups*. World Scientific Publishing Co. Pte. Ltd., Hackensack, NJ, 2011.
- [GS05] W. T. Gan and G. Savin, “On minimal representations definitions and properties,” *Represent. Theory* **9** (2005) 46–93 (electronic).
- [GS18] D. Gourevitch and S. Sahi, “Generalized and degenerate Whittaker quotients and Fourier coefficients,” [1808.00890 \[math.RT\]](#).
- [GV06] M. B. Green and P. Vanhove, “Duality and higher derivative terms in M theory,” *J. High Energy Phys.* no. 1, (2006) 093, 37.
- [Har77] R. Hartshorne, *Algebraic geometry*. Springer-Verlag, New York-Heidelberg, 1977. Graduate Texts in Mathematics, No. 52.
- [HT95] C. M. Hull and P. K. Townsend, “Unity of superstring dualities,” *Nucl. Phys.* **B438** (1995) 109–137, [arXiv:hep-th/9410167 \[hep-th\]](#). [,236(1994)].
- [JLS16] D. Jiang, B. Liu, and G. Savin, “Raising nilpotent orbits in wave-front sets,” *Represent. Theory* **20** (2016) 419–450.
- [KP04] D. Kazhdan and A. Polishchuk, “Minimal representations: spherical vectors and automorphic functionals,” in *Algebraic groups and arithmetic*, pp. 127–198. Tata Inst. Fund. Res., Mumbai, 2004. [arXiv:math/0209315](#).
- [KS15] T. Kobayashi and G. Savin, “Global uniqueness of small representations,” *Math. Z.* **281** no. 1-2, (2015) 215–239.
- [KV98] I. K. Kostov and P. Vanhove, “Matrix string partition functions,” *Phys. Lett.* **B444** (1998) 196–203, [arXiv:hep-th/9809130 \[hep-th\]](#).
- [Mat87] H. Matumoto, “Whittaker vectors and associated varieties,” *Invent. Math.* **89** no. 1, (1987) 219–224.
- [MNS00] G. W. Moore, N. Nekrasov, and S. Shatashvili, “D particle bound states and generalized instantons,” *Commun. Math. Phys.* **209** (2000) 77–95, [arXiv:hep-th/9803265 \[hep-th\]](#).
- [MS12] S. D. Miller and S. Sahi, “Fourier coefficients of automorphic forms, character variety orbits, and small representations,” *J. Number Theory* **132** no. 12, (2012) 3070–3108.
- [MW87] C. Mœglin and J.-L. Waldspurger, “Modèles de Whittaker dégénérés pour des groupes p -adiques,” *Math. Z.* **196** no. 3, (1987) 427–452.
- [MW95] C. Mœglin and J.-L. Waldspurger, *Spectral decomposition and Eisenstein series*, vol. 113 of *Cambridge Tracts in Mathematics*. Cambridge University Press, Cambridge, 1995. Une paraphrase de l’Écriture [A paraphrase of Scripture].
- [Đok98] D. Ž. Đoković, “Note on rational points in nilpotent orbits of semisimple groups,” *Indag. Math. (N.S.)* **9** no. 1, (1998) 31–34.
- [Per12] D. Persson, “Automorphic instanton partition functions on Calabi-Yau threefolds,” *J. Phys. Conf. Ser.* **346** (2012) 012016, [arXiv:1103.1014 \[hep-th\]](#).
- [Pio10] B. Pioline, “ R^4 couplings and automorphic unipotent representations,” *JHEP* **03** (2010) 116, [arXiv:1001.3647 \[hep-th\]](#).
- [PP09] B. Pioline and D. Persson, “The automorphic NS5-brane,” *Commun. Num. Theor. Phys.* **3** (2009) 697–754, [arXiv:0902.3274 \[hep-th\]](#).
- [PS79] I. I. Piatetski-Shapiro, “Multiplicity one theorems,” in *Automorphic forms, representations and L-functions (Proc. Sympos. Pure Math., Oregon State Univ., Corvallis, Ore., 1977), Part 1*, Proc. Sympos. Pure Math., XXXIII, pp. 209–212. Amer. Math. Soc., Providence, R.I., 1979.
- [Ros95] W. Rossmann, “Picard-Lefschetz theory and characters of a semisimple Lie group,” *Invent. Math.* **121** no. 3, (1995) 579–611.
- [Sha74] J. A. Shalika, “The multiplicity one theorem for GL_n ,” *Ann. of Math. (2)* **100** (1974) 171–193.

- [Var14] S. Varma, “On a result of Mœglin and Waldspurger in residual characteristic 2,”
Math. Z. **277** no. 3-4, (2014) 1027–1048.
- [Wei18] M. H. Weissman, “L-groups and parameters for covering groups,”
Astérisque no. 398, (2018) 33–186. L-groups and the Langlands program for covering groups.

DMITRY GOUREVITCH, FACULTY OF MATHEMATICS AND COMPUTER SCIENCE, WEIZMANN INSTITUTE OF SCIENCE, POB 26, REHOVOT 76100, ISRAEL

E-mail address: `dmitry.gourevitch@weizmann.ac.il`

URL: <http://www.wisdom.weizmann.ac.il/~dimagur>

HENRIK GUSTAFSSON, DEPARTMENT OF MATHEMATICS, STANFORD UNIVERSITY, STANFORD, CA 94305

E-mail address: `gustafsson@stanford.edu`

URL: <http://hgustafsson.se>

AXEL KLEINSCHMIDT, *Max-Planck-Institut für Gravitationsphysik (Albert-Einstein-Institut)*, AM MÜHLENBERG 1, DE-14476 POTSDAM, GERMANY, AND *International Solvay Institutes*, ULB-CAMPUS PLAINE CP231, BE-1050, BRUSSELS, BELGIUM

E-mail address: `axel.kleinschmidt@aei.mpg.de`

DANIEL PERSSON, CHALMERS UNIVERSITY OF TECHNOLOGY, DEPARTMENT OF MATHEMATICAL SCIENCES, SE-412 96 GOTHENBURG, SWEDEN

E-mail address: `daniel.persson@chalmers.se`

SIDDHARTHA SAHI, DEPARTMENT OF MATHEMATICS, RUTGERS UNIVERSITY, HILL CENTER - BUSCH CAMPUS, 110 FRELINGHUYSEN ROAD PISCATAWAY, NJ 08854-8019, USA

E-mail address: `sahi@math.rugers.edu`